

32" LCD TV

chassis FL11.4

SERVICE MANUAL

Contents

TYPE A

32MF301B/F7	MAGNAVOX	(Serial No.: DS1, DS2)
LC320EM2	EMERSON	(Serial No.: DS1, DS3)
LC320SS2	SYLVANIA	(Serial No.: DS1, DS2)

TYPE B

32MF301B/F7	MAGNAVOX	(Serial No.: TH1)
LC320SS2	SYLVANIA	(Serial No.: TH1)
LC320EM2	EMERSON	(Serial No.: TH1)

This service manual contains information of different types of models.
Make sure to refer to the section describing your model.

© 2011 Funai Electric Co., Ltd.

All rights reserved. No part of this manual may be reproduced, copied, transmitted, disseminated, transcribed, downloaded or stored in any storage medium, in any form or for any purpose without the express prior written consent of Funai. Furthermore, any unauthorized commercial distribution of this manual or any revision hereto is strictly prohibited.

Information in this document is subject to change without notice. Funai reserves the right to change the content herein without the obligation to notify any person or organization of such changes.

FUNAI with the  design is a registered trademark of Funai Electric Co., Ltd and may not be used in any way without the express written consent of Funai. All other trademarks used herein remain the exclusive property of their respective owners. Nothing contained in this manual should be construed as granting, by implication or otherwise, any license or right to use any of the trademarks displayed herein. Misuse of any trademarks or any other content in this manual is strictly prohibited. Funai shall aggressively enforce its intellectual property rights to the fullest extent of the law.

IMPORTANT SAFETY NOTICE

Proper service and repair is important to the safe, reliable operation of all Funai Equipment. The service procedures recommended by Funai and described in this service manual are effective methods of performing service operations. Some of these service special tools should be used when and as recommended.

It is important to note that this service manual contains various CAUTIONS and NOTICES which should be carefully read in order to minimize the risk of personal injury to service personnel. The possibility exists that improper service methods may damage the equipment. It also is important to understand that these CAUTIONS and NOTICES ARE NOT EXHAUSTIVE. Funai could not possibly know, evaluate and advice the service trade of all conceivable ways in which service might be done or of the possible hazardous consequences of each way. Consequently, Funai has not undertaken any such broad evaluation. Accordingly, a servicer who uses a service procedure or tool which is not recommended by Funai must first use all precautions thoroughly so that neither his safety nor the safe operation of the equipment will be jeopardized by the service method selected.

The LCD panel is manufactured to provide many years of useful life. Occasionally a few non active pixels may appear as a tiny spec of color. This is not to be considered a defect in the LCD screen.

TABLE OF CONTENTS

Specifications	1-1
Important Safety Precautions	2-1
Standard Notes for Servicing	3-1
Cabinet Disassembly Instructions [TYPE A]	4-1
[TYPE B]	4-5
Electrical Adjustment Instructions	5-1
How to Initialize the LCD TV	6-1
Firmware Renewal Mode	7-1
Troubleshooting	8-1
Block Diagrams	9-1
Schematic Diagrams / CBA and Test Points	10-1
Waveforms	11-1
Wiring Diagram	12-1
Exploded Views [TYPE A]	13-1
[TYPE B]	13-2
Parts List [TYPE A]	14-1
[TYPE B]	14-10
Revision History	15-1

SPECIFICATIONS

< TUNER / NTSC >

ANT. Input ----- 75 Ω Unbal., F type

Description	Condition	Unit	Nominal	Limit
1. AFT Pull-In Range	---	MHz	±2.3	±2.1
2. Synchronizing Sens.	TV.ch.4	dBμ	18	20
	CA.ch.31	dBμ	18	20
	CA.ch.87	dBμ	18	23

< TUNER / ATSC >

Description	Condition	Unit	Nominal	Limit
1. Received Freq. Range (-28dBm)	---	kHz	---	±100
2. ATSC Dynamic Range (min / max)	ch.4	dBm	---	-76/0
	ch.10	dBm	---	-76/0
	ch.41	dBm	---	-76/+4

< LCD PANEL >

Description	Condition	Unit	Nominal	Limit
1. Native Pixel Resolution	Horizontal	pixels	1366	---
	Vertical	pixels	768	---
2. Brightness (w / filter)	---	cd/m ²	300	---
3. Viewing Angle	Horizontal	°	-88 to 88	---
	Vertical	°	-88 to 88	---

< VIDEO >

Description	Condition	Unit	Nominal	Limit
1. Over Scan	Horizontal	%	5	5±5
	Vertical	%	5	5±5
2. Color Temperature	---	°K	12000	---
	x		0.272	±2%
	y		0.278	±2%
	<Measurement condition> Input signal: Internal pattern (40/70% raster) Measurement point: Screen center Measuring instrument: Made of KONICA MINOLTA Luminance meter CA-310 Aging time: 60min. (Retail MODE / 100IRE Raster HDMI 1080i@60) MODE setting of TV: Shipment setting / Retail MODE Ambient temperature: 25°C ±5°C			
3. Resolution (composite video)	Horizontal	line	400	---
	Vertical	line	350	---

< AUDIO >

All items are measured across 8 Ω load at speaker output terminal with L.P.F.

Description	Condition	Unit	Nominal	Limit
1. Audio MAX Output (ATSC 0dBfs)	Lch/Rch	W	5.0/5.0	4.0/4.0
2. Audio Distortion (NTSC)	500mW: Lch/Rch	%	0.5/0.5	2.0/2.0
3. Audio Freq. Response (NTSC)	-6dB: Lch	Hz	70 to 10 k	100 to 8 k
	-6dB: Rch	Hz	70 to 10 k	100 to 8 k

IMPORTANT SAFETY PRECAUTIONS

Prior to shipment from the factory, our products are strictly inspected for recognized product safety and electrical codes of the countries in which they are to be sold. However, in order to maintain such compliance, it is equally important to implement the following precautions when a set is being serviced.

Safety Precautions for LCD TV Circuit

1. **Before returning an instrument to the customer**, always make a safety check of the entire instrument, including, but not limited to, the following items:

a. Be sure that no built-in protective devices are defective and have been defeated during servicing. (1) Protective shields are provided on this chassis to protect both the technician and the customer. Correctly replace all missing protective shields, including any removed for servicing convenience. (2) When reinstalling the chassis and/or other assembly in the cabinet, be sure to put back in place all protective devices, including but not limited to, nonmetallic control knobs, insulating fishpapers, adjustment and compartment covers/shields, and isolation resistor/capacitor networks. **Do not operate this instrument or permit it to be operated without all protective devices correctly installed and functioning. Servicers who defeat safety features or fail to perform safety checks may be liable for any resulting damage.**

b. Be sure that there are no cabinet openings through which an adult or child might be able to insert their fingers and contact a hazardous voltage. Such openings include, but are not limited to, (1) spacing between the Liquid Crystal Panel and the cabinet mask, (2) excessively wide cabinet ventilation slots, and (3) an improperly fitted and/or incorrectly secured cabinet back cover.

c. **Antenna Cold Check** - With the instrument AC plug removed from any AC source, connect an electrical jumper across the two AC plug prongs. Place the instrument AC switch in the on position. Connect one lead of an ohmmeter to the AC plug prongs tied together and touch the other ohmmeter lead in turn to each tuner antenna input exposed terminal screw and, if applicable, to the coaxial connector. If the measured resistance is less than 1.0 megohm or greater than 5.2 megohm, an abnormality exists that must be corrected before the instrument is returned to the customer. Repeat this test with the instrument AC switch in the off position.

d. **Leakage Current Hot Check** - With the instrument completely reassembled, plug the AC line cord directly into a 120 V AC outlet. (Do not use an isolation transformer during this test.) Use a leakage current tester or a metering system that complies with American National Standards Institute (ANSI) C101.1 Leakage Current for Appliances and Underwriters Laboratories (UL) 1410, (50.7). With the instrument AC switch first in the on position and then in the off position, measure from a known earth ground (metal water pipe, conduit, etc.) to all exposed metal parts of the instrument (antennas, handle brackets, metal cabinet, screw heads, metallic overlays, control shafts, etc.), especially any exposed metal parts that offer an electrical return path to the chassis. Any current measured must not exceed 0.5 milli-ampere. Reverse the instrument power cord plug in the outlet and repeat the test.

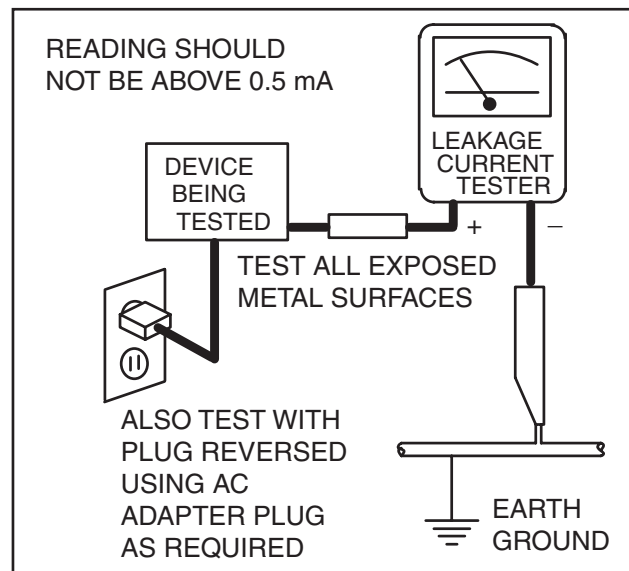

ANY MEASUREMENTS NOT WITHIN THE LIMITS SPECIFIED HEREIN INDICATE A POTENTIAL SHOCK HAZARD THAT MUST BE ELIMINATED BEFORE RETURNING THE INSTRUMENT TO THE CUSTOMER OR BEFORE CONNECTING THE ANTENNA OR ACCESSORIES.

2. Read and comply with all caution and safety-related notes on or inside the receiver cabinet, on the receiver chassis, or on the Liquid Crystal Panel.

3. **Design Alteration Warning** - Do not alter or add to the mechanical or electrical design of this TV receiver. Design alterations and additions, including, but not limited to circuit modifications and the addition of items such as auxiliary audio and/or video output connections, might alter the safety characteristics of this receiver and create a hazard to the user. Any design alterations or additions will void the manufacturer's warranty and may make you, the servicer, responsible for personal injury or property damage resulting therefrom.
4. **Hot Chassis Warning** -
 - a. Some TV receiver chassis are electrically connected directly to one conductor of the AC power cord and maybe safety-serviced without an isolation transformer only if the AC power plug is inserted so that the chassis is connected to the ground side of the AC power source. To confirm that the AC power plug is inserted correctly, with an AC voltmeter, measure between the chassis and a known earth ground. If a voltage reading in excess of 1.0 V is obtained, remove and reinsert the AC power plug in the opposite polarity and again measure the voltage potential between the chassis and a known earth ground.
 - b. Some TV receiver chassis normally have 85V AC(RMS) between chassis and earth ground regardless of the AC plug polarity. This chassis can be safety-serviced only with an isolation transformer inserted in the power line between the receiver and the AC power source, for both personnel and test equipment protection.
 - c. Some TV receiver chassis have a secondary ground system in addition to the main chassis ground. This secondary ground system is not isolated from the AC power line. The two ground systems are electrically separated by insulation material that must not be defeated or altered.
5. Observe original lead dress. Take extra care to assure correct lead dress in the following areas: a. near sharp edges, b. near thermally hot parts-be sure that leads and components do not touch thermally hot parts, c. the AC supply, d. high voltage, and, e. antenna wiring. Always inspect in all areas for pinched, out of place, or frayed wiring. Check AC power cord for damage.
6. Components, parts, and/or wiring that appear to have overheated or are otherwise damaged should be replaced with components, parts, or wiring that meet original specifications. Additionally, determine the cause of overheating and/or damage and, if necessary, take corrective action to remove any potential safety hazard.
7. **Product Safety Notice** - Some electrical and mechanical parts have special safety-related characteristics which are often not evident from visual inspection, nor can the protection they give necessarily be obtained by replacing them with components rated for higher voltage, wattage, etc. Parts that have special safety characteristics are identified by a  on schematics and in parts lists. Use of a substitute replacement that does not have the same safety characteristics as the recommended replacement part might create shock, fire, and/or other hazards. The product's safety is under review continuously and new instructions are issued whenever appropriate. Prior to shipment from the factory, our products are strictly inspected to confirm they comply with the recognized product safety and electrical codes of the countries in which they are to be sold. However, in order to maintain such compliance, it is equally important to implement the following precautions when a set is being serviced.

Precautions during Servicing

- A.** Parts identified by the **▲** symbol are critical for safety.
Replace only with part number specified.
- B.** In addition to safety, other parts and assemblies are specified for conformance with regulations applying to spurious radiation. These must also be replaced only with specified replacements.
Examples: RF converters, RF cables, noise blocking capacitors, and noise blocking filters, etc.
- C.** Use specified internal wiring. Note especially:
 - 1) Wires covered with PVC tubing
 - 2) Double insulated wires
 - 3) High voltage leads
- D.** Use specified insulating materials for hazardous live parts. Note especially:
 - 1) Insulation Tape
 - 2) PVC tubing
 - 3) Spacers
 - 4) Insulators for transistors.
- E.** When replacing AC primary side components (transformers, power cord, etc.), wrap ends of wires securely about the terminals before soldering.
- F.** Observe that the wires do not contact heat producing parts (heat sinks, oxide metal film resistors, fusible resistors, etc.)
- G.** Check that replaced wires do not contact sharp edged or pointed parts.
- H.** When a power cord has been replaced, check that 11~13 lb (5~6 kg) of force in any direction will not loosen it.
- I.** Also check areas surrounding repaired locations.
- J.** Use care that foreign objects (screws, solder droplets, etc.) do not remain inside the set.
- K.** When connecting or disconnecting the internal connectors, first, disconnect the AC plug from the AC supply outlet.
- L.** When installing parts or assembling the cabinet parts, be sure to use the proper screws and tighten certainly.

Safety Check after Servicing

Examine the area surrounding the repaired location for damage or deterioration. Observe that screws, parts and wires have been returned to original positions. Afterwards, perform the following tests and confirm the specified values in order to verify compliance with safety standards.

1. Clearance Distance

When replacing primary circuit components, confirm specified clearance distance (d) and (d') between soldered terminals, and between terminals and surrounding metallic parts. (See Fig. 1)

Table 1: Ratings for selected area

AC Line Voltage	Region	Clearance Distance (d), (d')
110 to 130 V	U.S.A. or Canada	≥ 3.2 mm (0.126 inches)

Note: This table is unofficial and for reference only. Be sure to confirm the precise values.

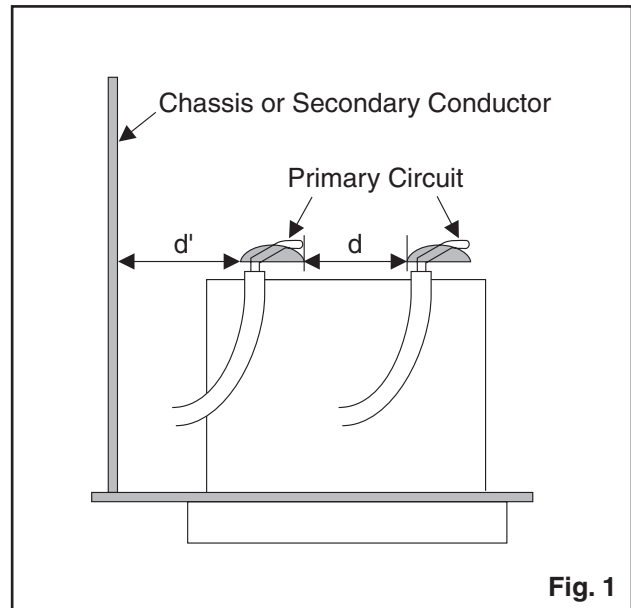

Fig. 1

2. Leakage Current Test

Confirm the specified (or lower) leakage current between B (earth ground, power cord plug prongs) and externally exposed accessible parts (RF terminals, antenna terminals, video and audio input and output terminals, microphone jacks, earphone jacks, etc.) is lower than or equal to the specified value in the table below.

Measuring Method: (Power ON)

Insert load Z between B (earth ground, power cord plug prongs) and exposed accessible parts. Use an AC voltmeter to measure across both terminals of load Z . See Fig. 2 and following table.

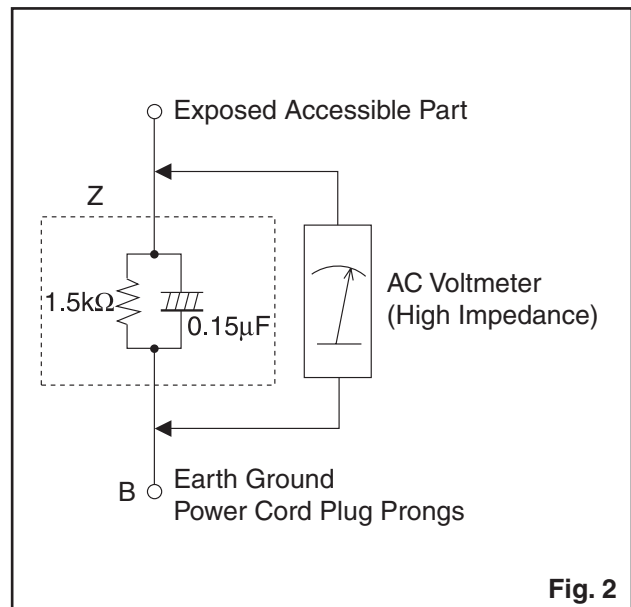

Fig. 2

Table 2: Leakage current ratings for selected areas

AC Line Voltage	Region	Load Z	Leakage Current (i)	Earth Ground (B) to:
110 to 130 V	U.S.A. or Canada	$0.15\mu\text{F}$ CAP. & $1.5\text{k}\Omega$ RES. Connected in parallel	$i \leq 0.5$ mA rms	Exposed accessible parts

Note: This table is unofficial and for reference only. Be sure to confirm the precise values.

STANDARD NOTES FOR SERVICING

Circuit Board Indications

1. The output pin of the 3 pin Regulator ICs is indicated as shown.

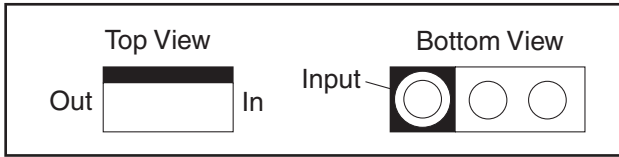

2. For other ICs, pin 1 and every fifth pin are indicated as shown.

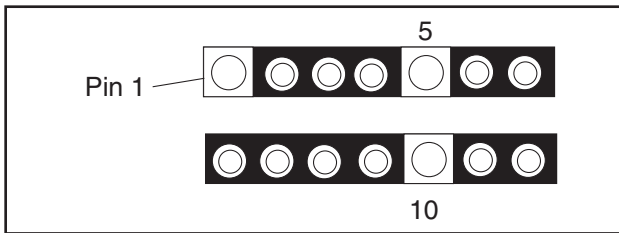

3. The 1st pin of every male connector is indicated as shown.

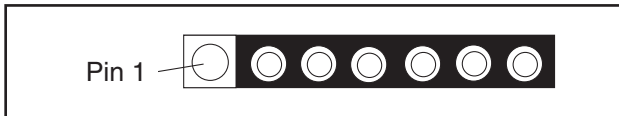

Pb (Lead) Free Solder

Pb free mark will be found on PCBs which use Pb free solder. (Refer to figure.) For PCBs with Pb free mark, be sure to use Pb free solder. For PCBs without Pb free mark, use standard solder.

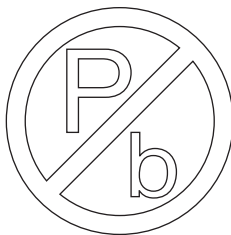

Pb free mark

How to Remove / Install Flat Pack-IC

1. Removal

With Hot-Air Flat Pack-IC Desoldering Machine:

1. Prepare the hot-air flat pack-IC desoldering machine, then apply hot air to the Flat Pack-IC (about 5 to 6 seconds). (Fig. S-1-1)

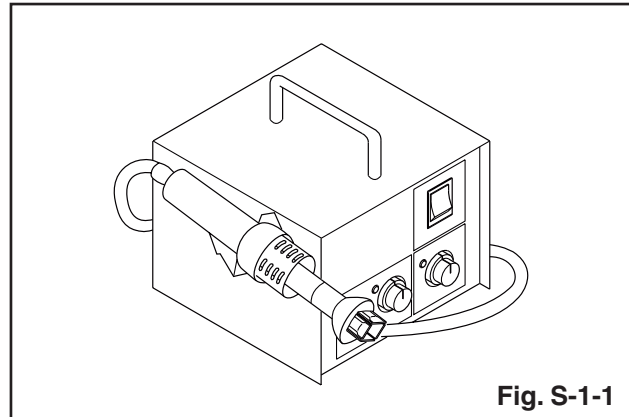

Fig. S-1-1

2. Remove the flat pack-IC with tweezers while applying the hot air.
3. Bottom of the flat pack-IC is fixed with glue to the CBA; when removing entire flat pack-IC, first apply soldering iron to center of the flat pack-IC and heat up. Then remove (glue will be melted). (Fig. S-1-6)
4. Release the flat pack-IC from the CBA using tweezers. (Fig. S-1-6)

CAUTION:

1. The Flat Pack-IC shape may differ by models. Use an appropriate hot-air flat pack-IC desoldering machine, whose shape matches that of the Flat Pack-IC.
2. Do not supply hot air to the chip parts around the flat pack-IC for over 6 seconds because damage to the chip parts may occur. Put masking tape around the flat pack-IC to protect other parts from damage. (Fig. S-1-2)

3. The flat pack-IC on the CBA is affixed with glue, so be careful not to break or damage the foil of each pin or the solder lands under the IC when removing it.

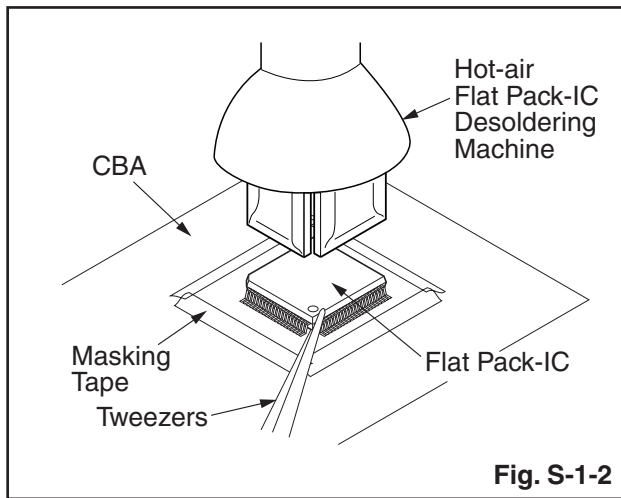

With Soldering Iron:

1. Using desoldering braid, remove the solder from all pins of the flat pack-IC. When you use solder flux which is applied to all pins of the flat pack-IC, you can remove it easily. (Fig. S-1-3)

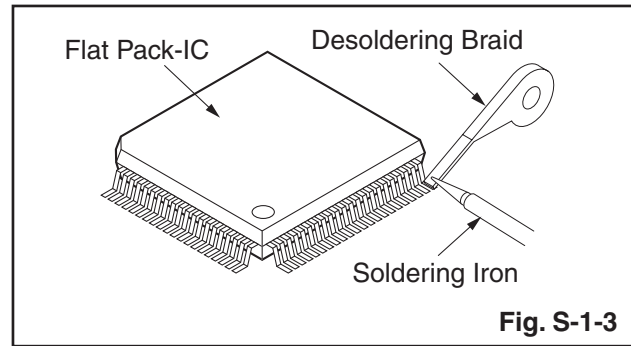

2. Lift each lead of the flat pack-IC upward one by one, using a sharp pin or wire to which solder will not adhere (iron wire). When heating the pins, use a fine tip soldering iron or a hot air desoldering machine. (Fig. S-1-4)

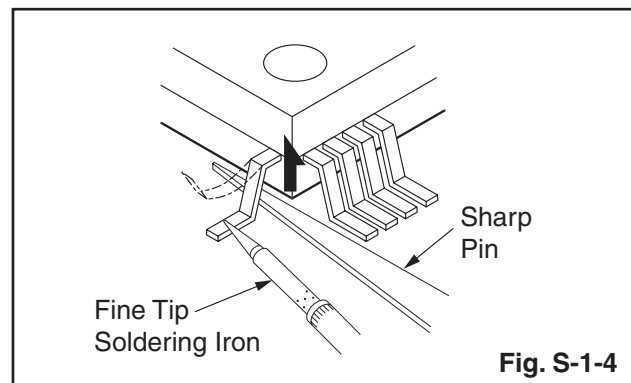

3. Bottom of the flat pack-IC is fixed with glue to the CBA; when removing entire flat pack-IC, first apply soldering iron to center of the flat pack-IC and heat up. Then remove (glue will be melted). (Fig. S-1-6)
4. Release the flat pack-IC from the CBA using tweezers. (Fig. S-1-6)

With Iron Wire:

1. Using desoldering braid, remove the solder from all pins of the flat pack-IC. When you use solder flux which is applied to all pins of the flat pack-IC, you can remove it easily. (Fig. S-1-3)
2. Affix the wire to a workbench or solid mounting point, as shown in Fig. S-1-5.
3. While heating the pins using a fine tip soldering iron or hot air blower, pull up the wire as the solder melts so as to lift the IC leads from the CBA contact pads as shown in Fig. S-1-5.
4. Bottom of the flat pack-IC is fixed with glue to the CBA; when removing entire flat pack-IC, first apply soldering iron to center of the flat pack-IC and heat up. Then remove (glue will be melted). (Fig. S-1-6)
5. Release the flat pack-IC from the CBA using tweezers. (Fig. S-1-6)

Note: When using a soldering iron, care must be taken to ensure that the flat pack-IC is not being held by glue. When the flat pack-IC is removed from the CBA, handle it gently because it may be damaged if force is applied.

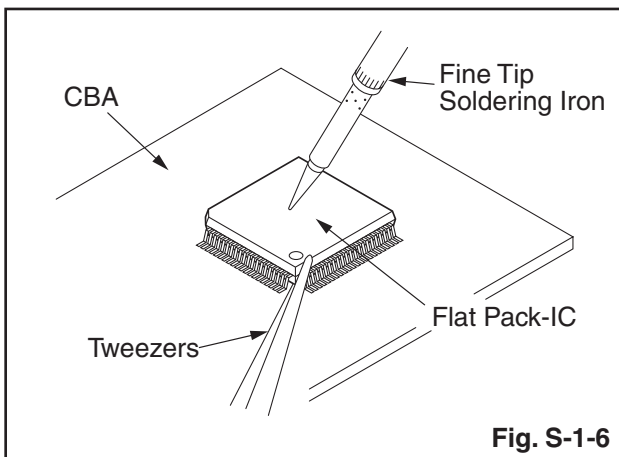
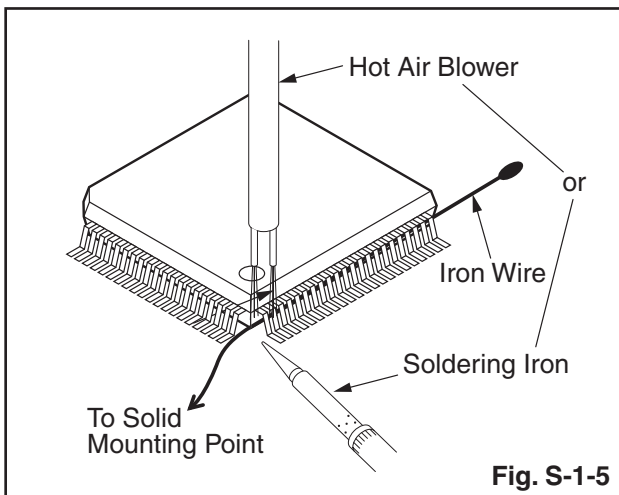

2. Installation

1. Using desoldering braid, remove the solder from the foil of each pin of the flat pack-IC on the CBA so you can install a replacement flat pack-IC more easily.
2. The "●" mark on the flat pack-IC indicates pin 1. (See Fig. S-1-7.) Be sure this mark matches the pin 1 on the PCB when positioning for installation. Then presolder the four corners of the flat pack-IC. (See Fig. S-1-8.)
3. Solder all pins of the flat pack-IC. Be sure that none of the pins have solder bridges.

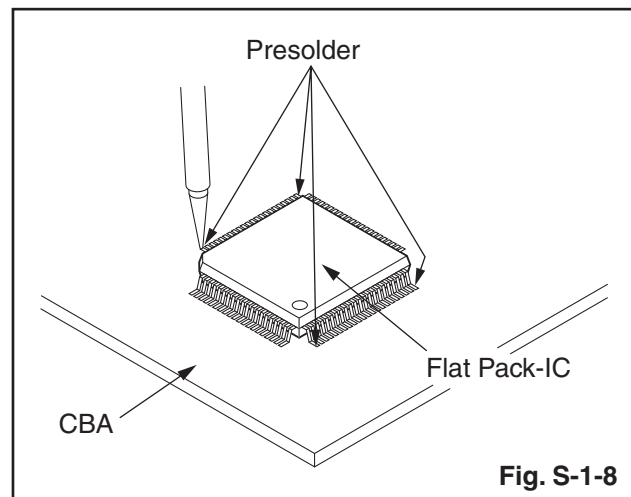
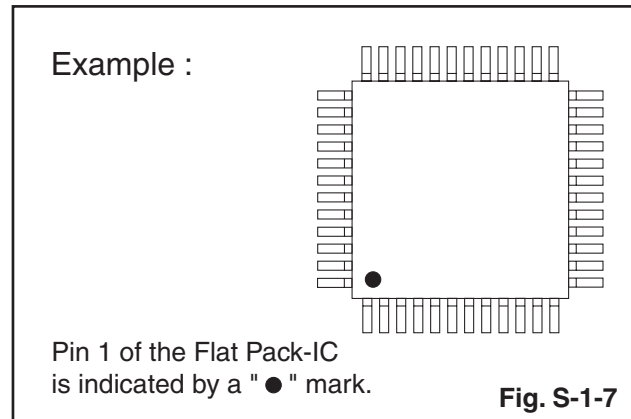

Instructions for Handling Semi-conductors

Electrostatic breakdown of the semi-conductors may occur due to a potential difference caused by electrostatic charge during unpacking or repair work.

1. Ground for Human Body

Be sure to wear a grounding band (1 M Ω) that is properly grounded to remove any static electricity that may be charged on the body.

2. Ground for Workbench

Be sure to place a conductive sheet or copper plate with proper grounding (1 M Ω) on the workbench or other surface, where the semi-conductors are to be placed. Because the static electricity charge on clothing will not escape through the body grounding band, be careful to avoid contacting semi-conductors with your clothing.

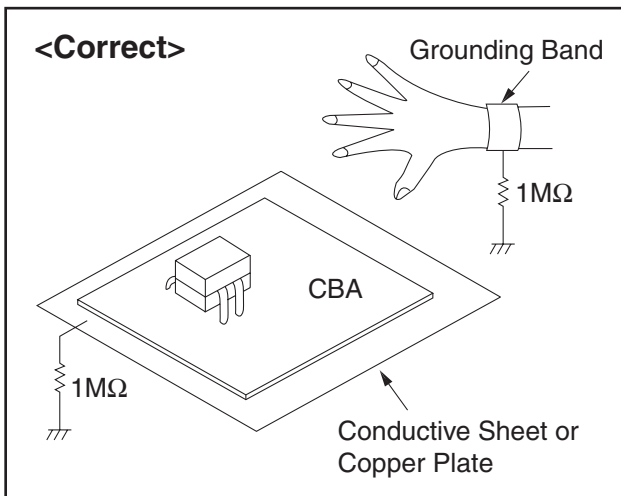
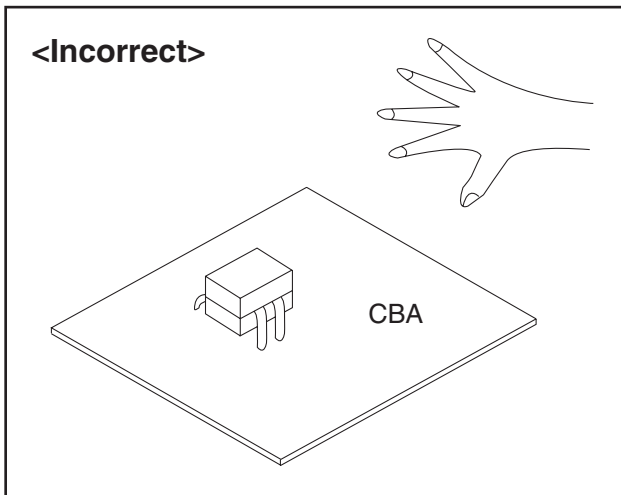

CABINET DISASSEMBLY INSTRUCTIONS

[TYPE A]

1. Disassembly Flowchart

This flowchart indicates the disassembly steps for the cabinet parts and the CBA in order to gain access to items to be serviced. When reassembling, follow the steps in reverse order. Bend, route and dress the cables as they were.

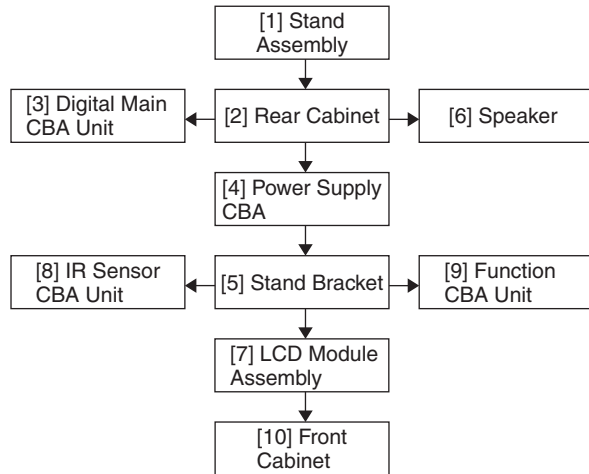

2. Disassembly Method

Step/ Loc. No.	Part	Fig. No.	Removal	Note
[1]	Stand Assembly	D1	3(S-1)	---
[2]	Rear Cabinet	D1	10(S-2), 3(S-3), 2(S-4), 13(L-1)	---
[3]	Digital Main CBA Unit	D2 D3	4(S-5), CN3005, CN3101, CN3102, CN3701, CN3801, CN3802, Jack Holder	---
[4]	Power Supply CBA	D2 D3	6(S-6), CN200, CN600* ¹ , CN601* ² , CN1100, CN1101, CN1102, Connector Cover* ¹	---
[5]	Stand Bracket	D2	(S-7)	---
[6]	Speaker	D2	4(S-8), Speaker Holder	---
[7]	LCD Module Assembly	D2	-----	---
[8]	IR Sensor CBA Unit	D2 D3	Sensor Lens	---

Step/ Loc. No.	Part	Fig. No.	Removal	Note
[9]	Function CBA Unit	D2 D3	Function Knob	---
[10]	Front Cabinet	D2	-----	---

↓ ↓ ↓ ↓ ↓
 (1) (2) (3) (4) (5)

***1: LC320EM2 (Serial No.: DS1),
32MF301B/F7 (Serial No.: DS1),
LC320SS2 (Serial No.: DS1)**

***2: LC320EM2 (Serial No.: DS3),
320MF301B/F7 (Serial No.: DS2),
LC320SS2 (Serial No.: DS2)**

Note:

- (1) Order of steps in procedure. When reassembling, follow the steps in reverse order. These numbers are also used as the Identification (location) No. of parts in figures.
- (2) Parts to be removed or installed.
- (3) Fig. No. showing procedure of part location
- (4) Identification of parts to be removed, unhooked, unlocked, released, unplugged, unclamped, or desoldered.
P = Spring, L = Locking Tab, S = Screw,
H = Hex Screw, CN = Connector
e.g. 2(S-2) = two Screws of (S-2),
2(L-2) = two Locking Tabs of (L-2)
- (5) Refer to the following "Reference Notes in the Table."

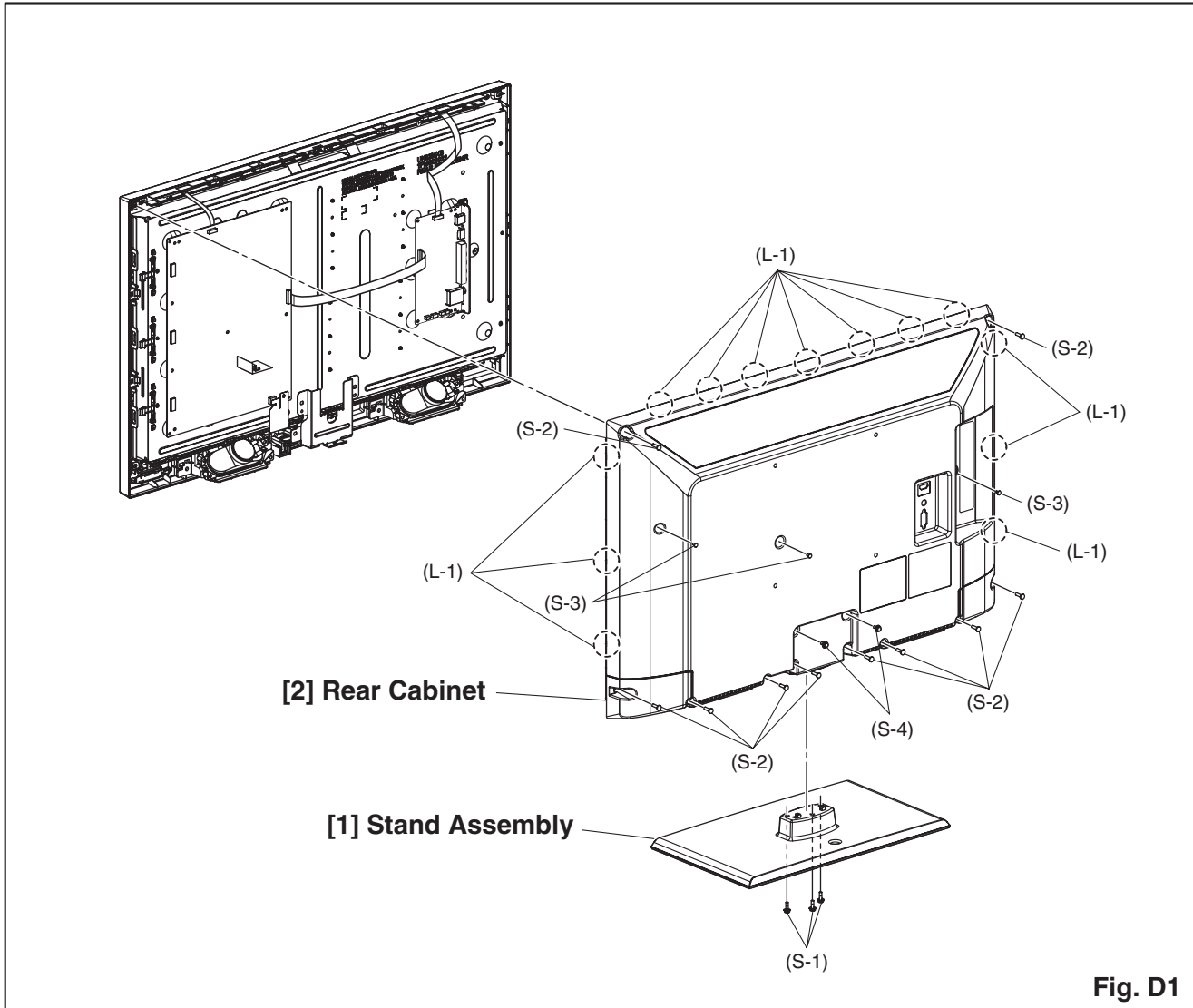

Fig. D1

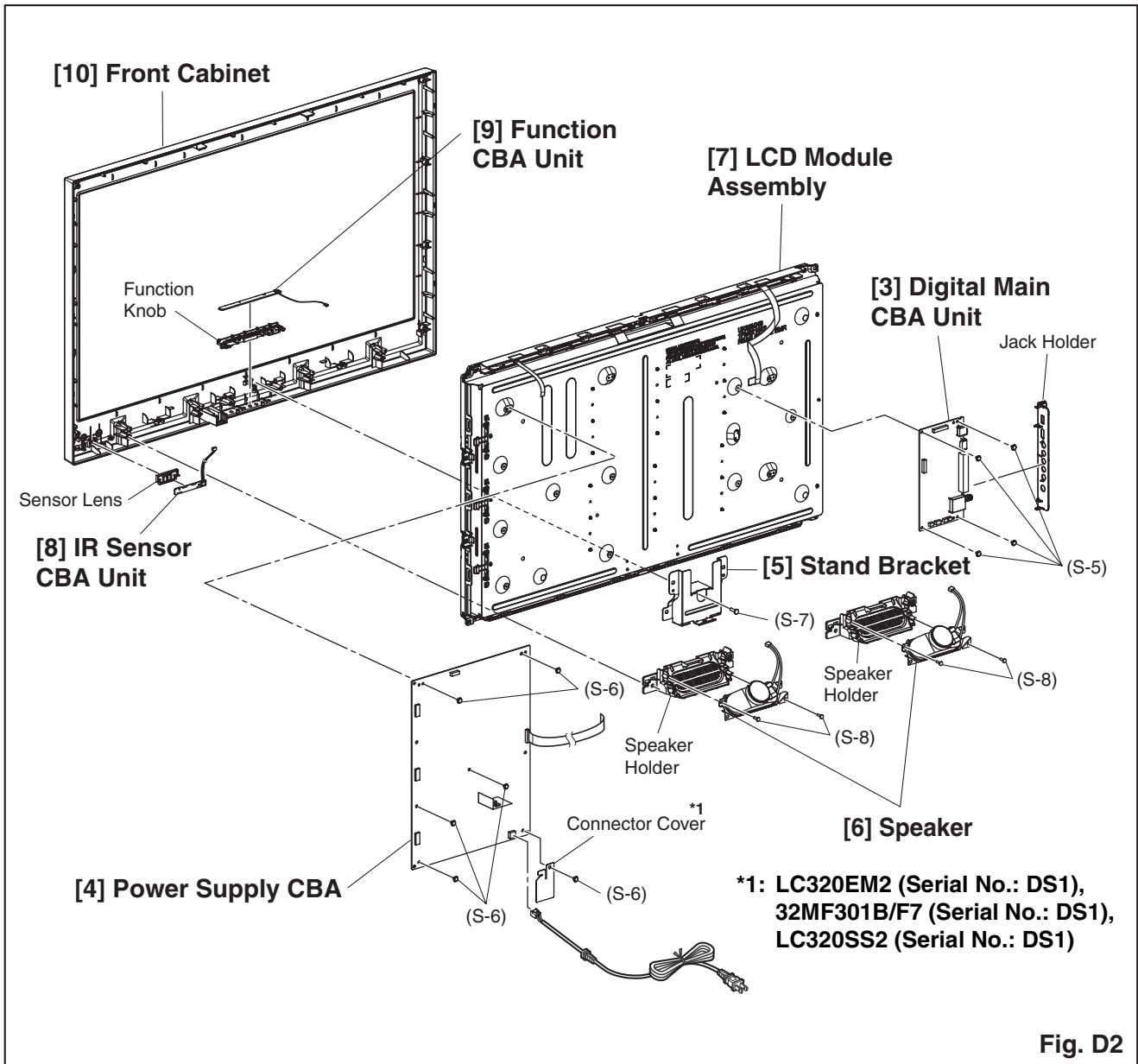

Fig. D2

TV Cable Wiring Diagram

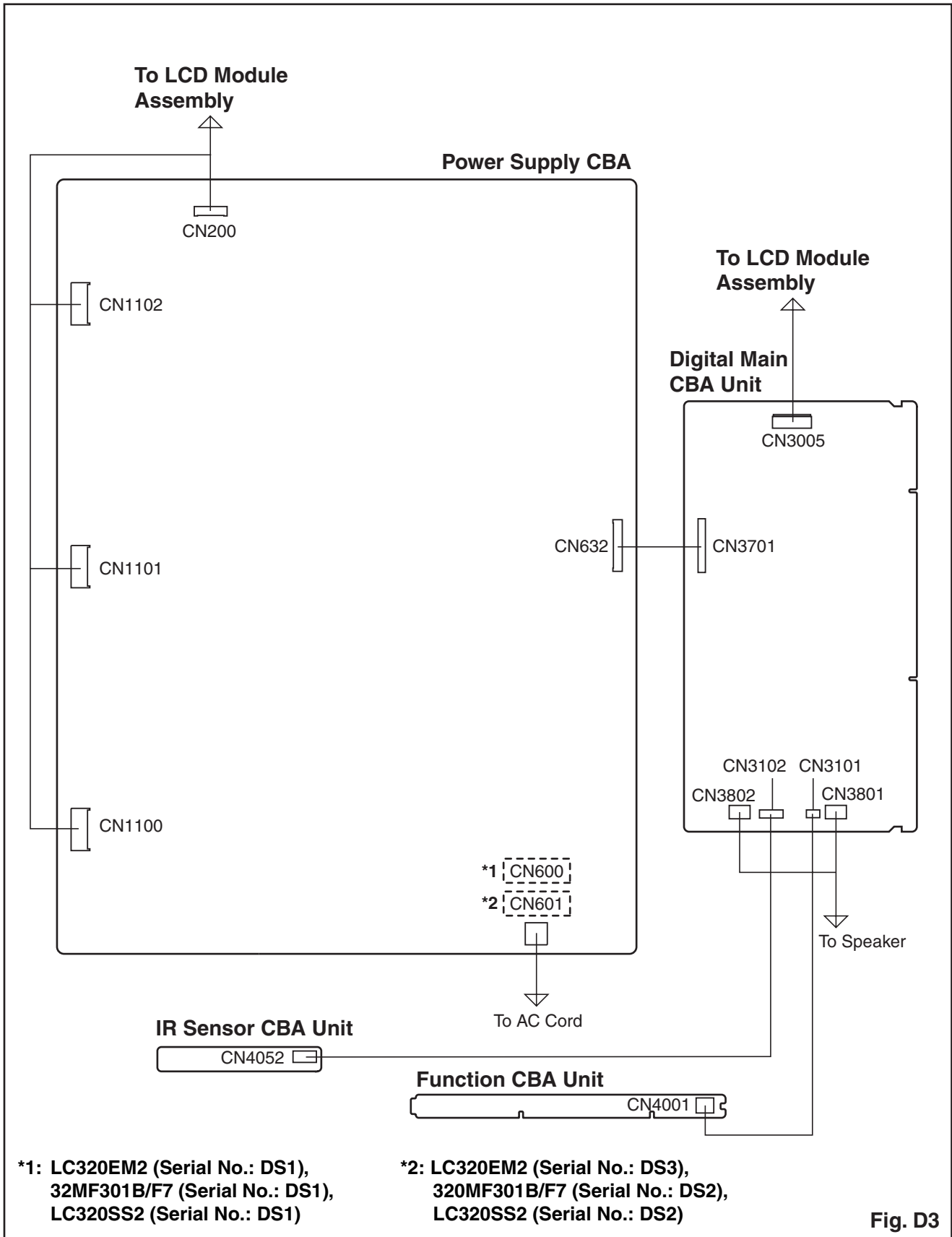
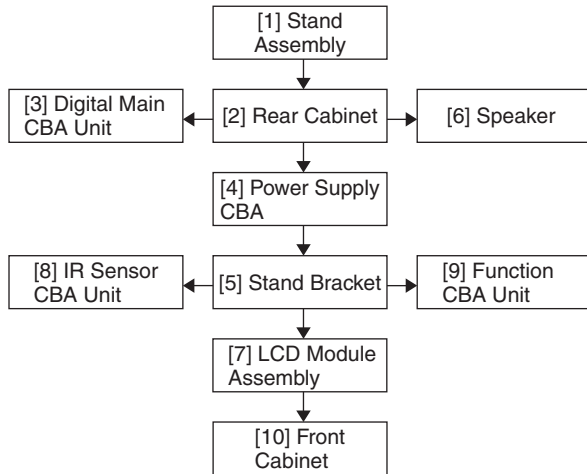

Fig. D3

[TYPE B]

1. Disassembly Flowchart

This flowchart indicates the disassembly steps for the cabinet parts and the CBA in order to gain access to items to be serviced. When reassembling, follow the steps in reverse order. Bend, route and dress the cables as they were.



2. Disassembly Method

Step/ Loc. No.	Part	Fig. No.	Removal	Note
[1]	Stand Assembly	D1	3(S-1)	---
[2]	Rear Cabinet	D1	10(S-2), 3(S-3), 2(S-4), 13(L-1)	---
[3]	Digital Main CBA Unit	D2 D3	4(S-5), CN3005, CN3101, CN3102, CN3701, CN3801, CN3802, Jack Holder	---
[4]	Power Supply CBA	D2 D3	6(S-6), CN200, CN601, CN1100, CN1101, CN1102	---
[5]	Stand Bracket	D2	(S-7)	---
[6]	Speaker	D2	4(S-8), Speaker Holder	---
[7]	LCD Module Assembly	D2	-----	---
[8]	IR Sensor CBA Unit	D2 D3	Sensor Lens	---

Step/ Loc. No.	Part	Fig. No.	Removal	Note
[9]	Function CBA Unit	D2 D3	Function Knob	---
[10]	Front Cabinet	D2	-----	---

↓ ↓ ↓ ↓ ↓
 (1) (2) (3) (4) (5)

Note:

- (1) Order of steps in procedure. When reassembling, follow the steps in reverse order. These numbers are also used as the Identification (location) No. of parts in figures.
- (2) Parts to be removed or installed.
- (3) Fig. No. showing procedure of part location
- (4) Identification of parts to be removed, unhooked, unlocked, released, unplugged, unclamped, or desoldered.
 P = Spring, L = Locking Tab, S = Screw,
 H = Hex Screw, CN = Connector
 e.g. 2(S-2) = two Screws of (S-2),
 2(L-2) = two Locking Tabs of (L-2)
- (5) Refer to the following "Reference Notes in the Table."

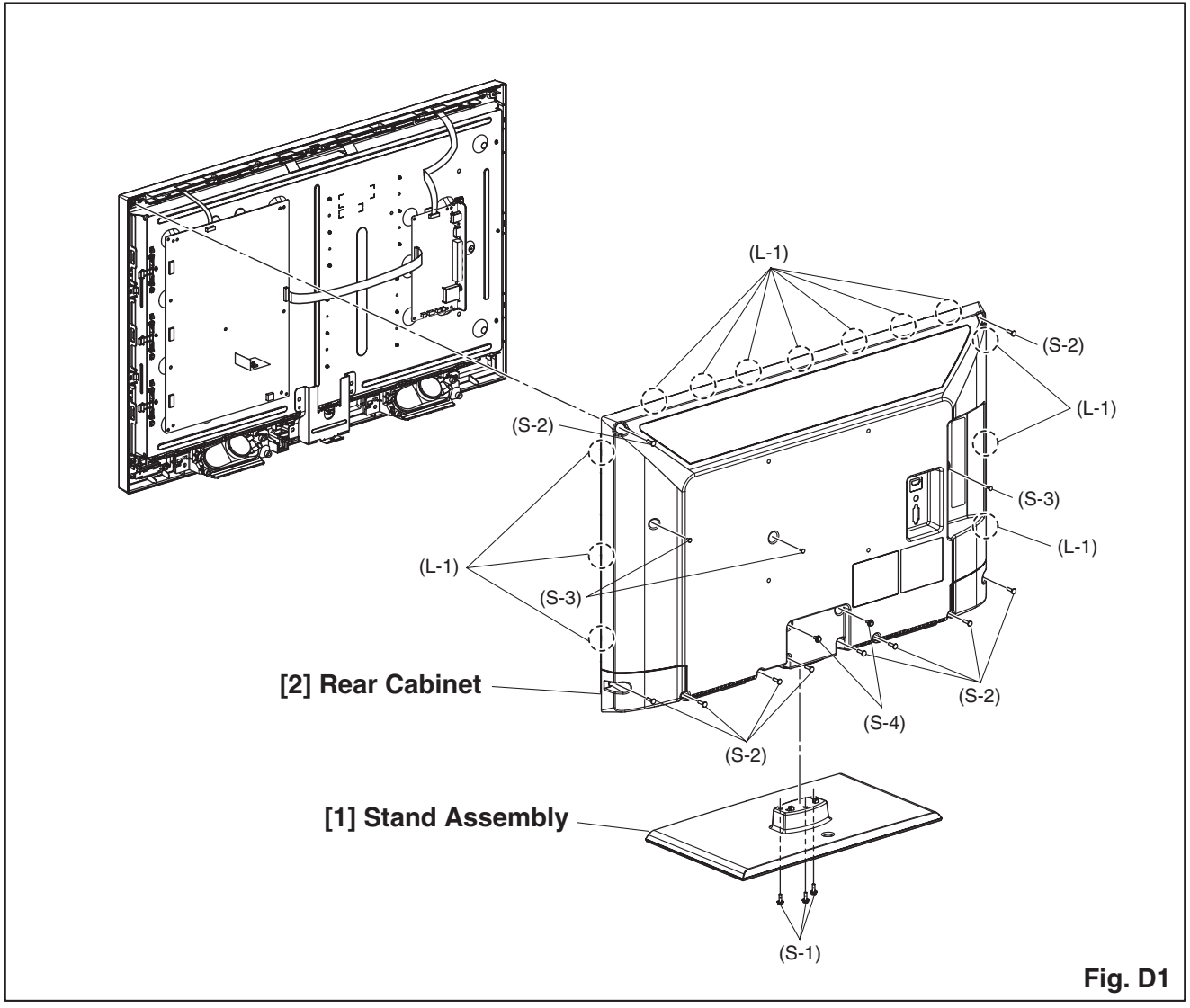

Fig. D1

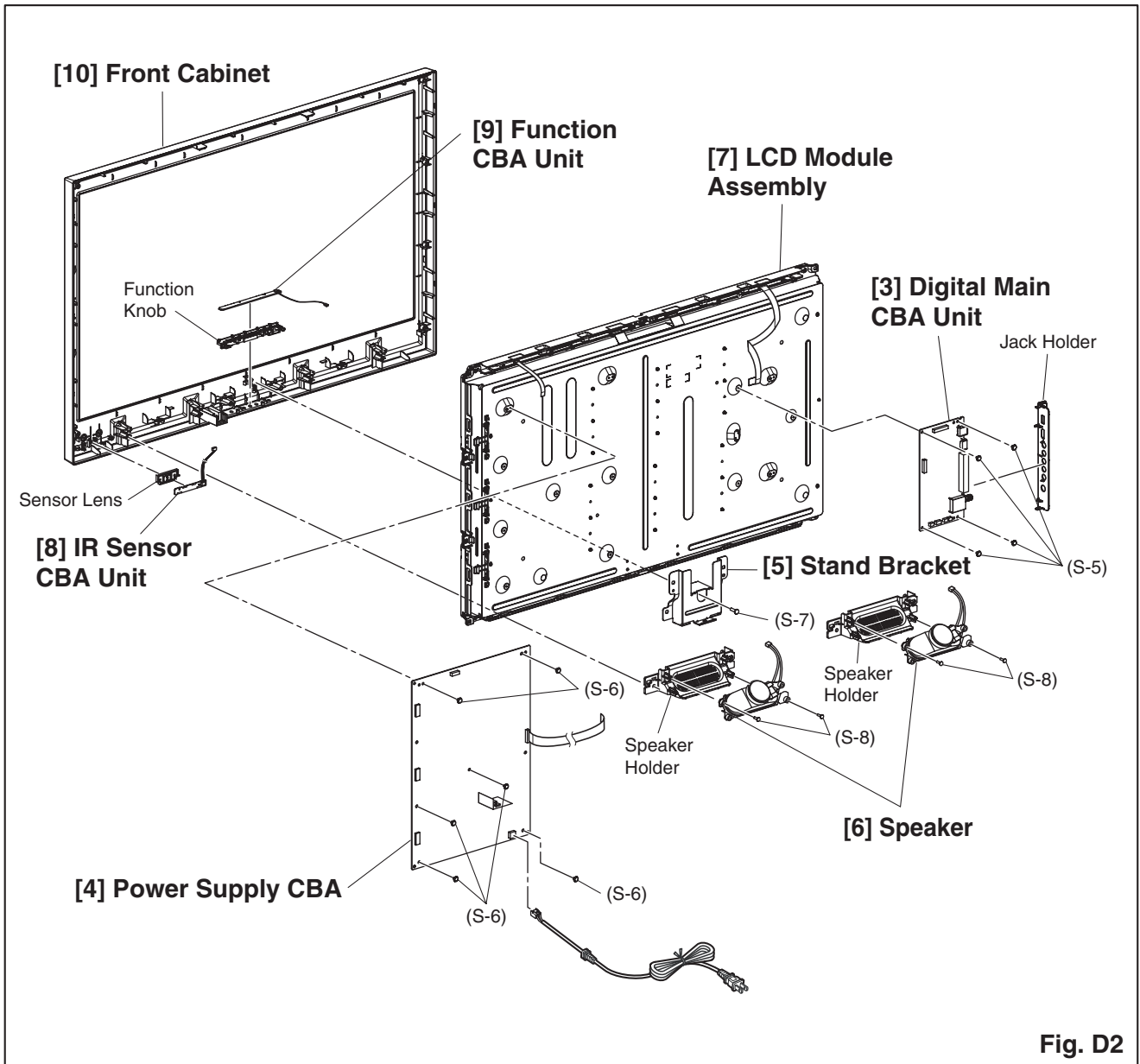

Fig. D2

TV Cable Wiring Diagram

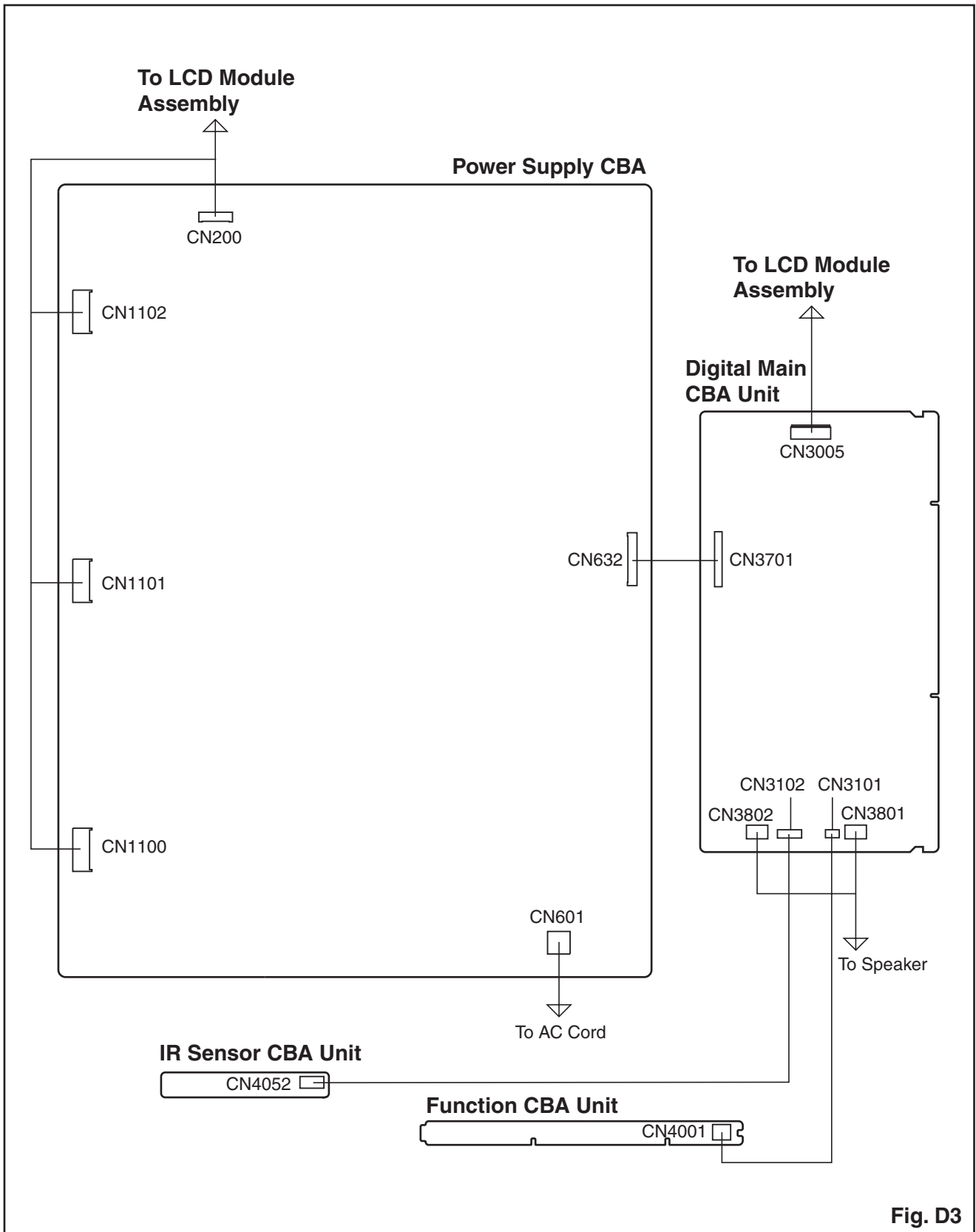

Fig. D3

ELECTRICAL ADJUSTMENT INSTRUCTIONS

General Note: “CBA” is abbreviation for “Circuit Board Assembly.”

Note: Electrical adjustments are required after replacing circuit components and certain mechanical parts. It is important to perform these adjustments only after all repairs and replacements have been completed. Also, do not attempt these adjustments unless the proper equipment is available.

Test Equipment Required

1. Remote control unit
2. Color Analyzer, CA-310 (KONICA MINOLTA Luminance meter) or measuring instrument as good as CA-310.

How to set up the service mode:

Service mode:

1. Turn the power on.
2. Press [MENU] button to display Setup menu.
3. Select “Features”.
4. Select “Current Software Info”.
5. Press [0], [4], [2], [5], [7], [4] and [INFO] buttons on the remote control unit in this order. The following screen appears.

“*” differs depending on the models.

Code:	*****_*_*_*_*_*_*_*_*_*_*
Pic code:	*****_*_*_*_*_*_*_*_*_*_*
Panel-Option code:	**_*_*_*_*_*_*_*_*_*_*
MIPS:	Push 0 key

Press "POWER" key to exit.

Tuner:	****_*_*_*_*_*_*_*_*_*_*		
Safety:	Safety_Non		
HDMI EDID:	**	Total Watch Time:	****
PC EDID:	**	Lightsensor:	****

1. Purity Check Mode

This mode cycles through full-screen displays of red, green, blue, and white to check for non-active pixels.

1. Enter the Service mode.
2. Each time the [7] button on the remote control unit is pressed, the display changes as follows.

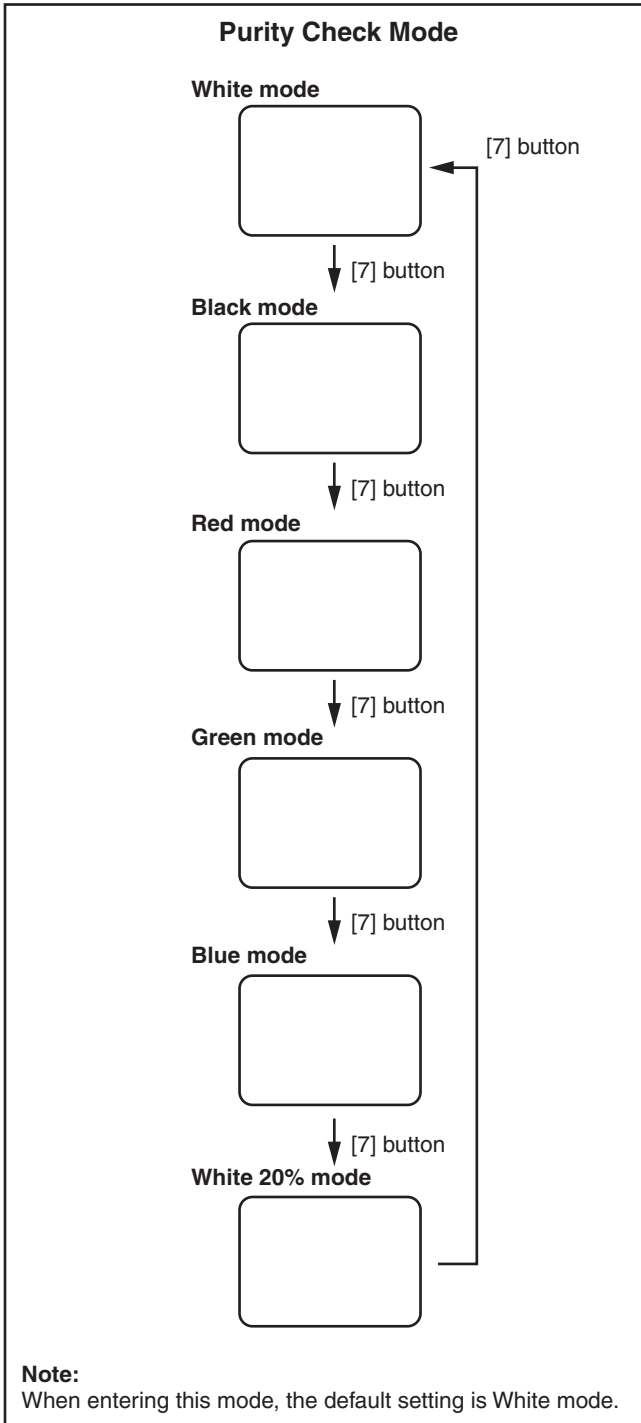

3. To cancel or to exit from the Purity Check Mode, press [CH RETURN] or [PREV CH] button.

2. VCOM Adjustment

Test Point	Adj. Point
Screen	[CHANNEL UP/DOWN] buttons
M. EQ.	Spec.
Color analyzer	See below

Figure

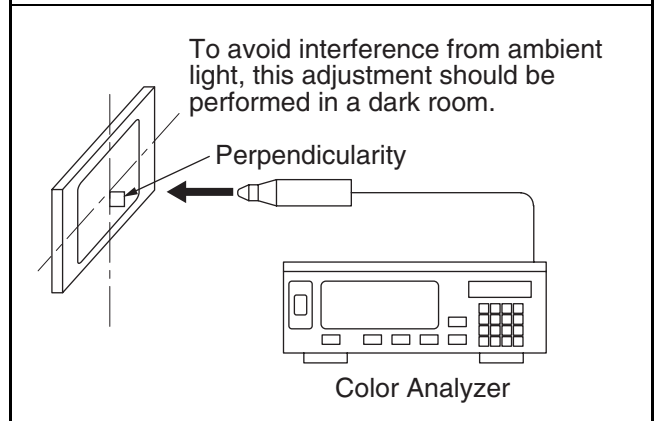

1. Operate the unit for more than 60 minutes.
2. Set the color analyzer at the zero point calibration and bring the optical receptor pointing at the center of the LCD-Panel.
Note: The optical receptor must be set perpendicularly to the LCD Panel surface.
3. Enter the Service mode.
4. Press [3] button on the remote control unit.
5. Press [CHANNEL UP/DOWN] buttons on the remote control unit so that the color analyzer value becomes minimum.
6. To cancel or to exit from the VCOM Adjustment, press [CH RETURN] or [PREV CH] button.

The White Balance Adjustment should be performed when replacing the LCD Panel or Digital Main CBA.

3. White Balance Adjustment

Purpose: To mix red and blue beams correctly for pure white.

Symptom of Misadjustment: White becomes bluish or reddish.

ITEM	SPECIFICATION
Color temperature	$x = 0.272 \pm 0.002$ $y = 0.278 \pm 0.002$
Input Signal	Internal pattern (40/70% raster)
Measurement point	Screen center
M. EQ.	CA-310 (KONICA MINOLTA Luminance meter) or measuring instrument as good as CA-310.
Aging time	60min. (Retail MODE/100IRE Raster HDMI 1080i @ 60)
MODE setting of TV	Shipment setting/ Retail MODE
Ambient temperature	$25^{\circ}\text{C} \pm 5^{\circ}\text{C}$

1. Operate the unit for more than 60 minutes.
2. Enter the Service mode.
3. Press [VOLUME DOWN] button three times on the remote control unit to select "Drive setting" mode. "Drive" appears on the screen.
4. Set the color analyzer at the CHROMA mode and zero point calibration. Bring the optical receptor pointing at the center of the LCD-Panel.

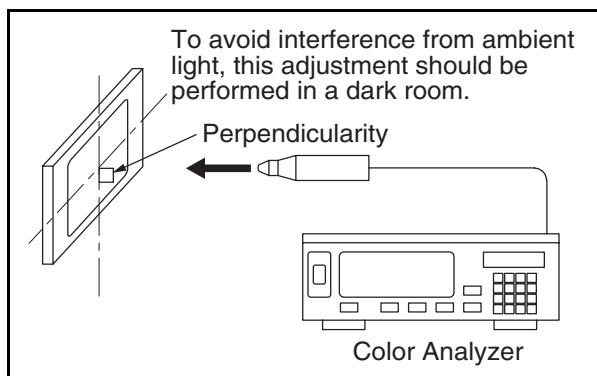

Note: The optical receptor must be set perpendicularly to the LCD Panel surface.

5. Press [3] button to select the "HDB" for High Drive Blue adjustment. ("HDB" appears on the screen.)

6. Press [MENU] button. The internal Raster signal appears on the screen. ("Internal (Single)" appears on the upper right of the screen as shown below.)

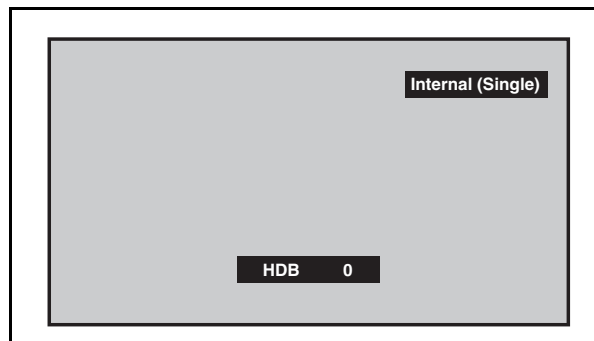

7. Press [CHANNEL UP/DOWN] buttons to adjust the color temperature becomes 12000°K ($x = 0.272 / y = 0.278 \pm 0.002$).
8. Press [1] button to select the "HDR" for High Drive Red adjustment ("HDR" appears on the screen.) and press [CHANNEL UP/DOWN] buttons to adjust the color temperature.
9. If necessary, adjust the "HDB" or "HDR" again.
10. Press [6] button to select the "LDB" for Low Drive Blue adjustment ("LDB" appears on the screen.) and press [CHANNEL UP/DOWN] buttons to adjust the color temperature.

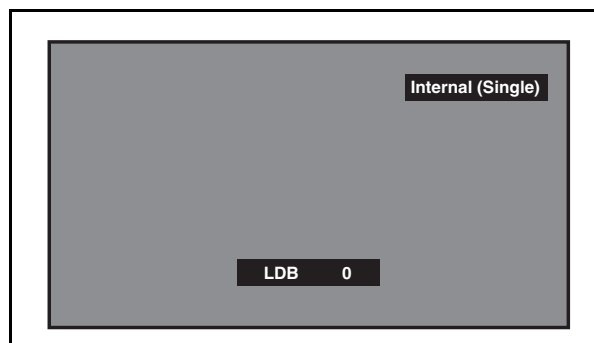

11. Press [4] button to select the "LDR" for Low Drive Red adjustment ("LDR" appears on the screen.) and press [CHANNEL UP/DOWN] buttons to adjust the color temperature.
12. If necessary, adjust the "LDB" or "LDR" again.
13. Press [VOLUME DOWN] button to shift to the "Debugging Message" mode. If there is no message under "[WB]" section, this adjustment completes. If "Drive settings are NG. Retry." is displayed, repeat above steps from 5. to 12. Then check "Debugging Message" again. If "Drive settings are NG. Retry." is displayed, replace the LCD Panel or Digital Main CBA.
14. To cancel or to exit from the White Balance Adjustment, press [CH RETURN] or [PREV CH] button.

HOW TO INITIALIZE THE LCD TV

The purpose of initialization is to place the set in a new out of box condition. The customer will be prompted to select a language and program channels after the set has been initialized.

To put the program back at the factory-default, initialize the LCD TV using the following procedure.

1. Turn the power on.
2. Enter the service mode.
 - To cancel the service mode, press [POWER] button on the remote control unit.
3. Press [FREEZE] button on the remote control unit to initialize the LCD television.
4. "INITIALIZED" will appear in the upper right of the screen. "INITIALIZED" color will change to green from red when initializing is completed.

FIRMWARE RENEWAL MODE

Equipment Required

- USB storage device
- Remote Control Unit

Firmware Update Procedure

Note: There are two states (the User Upgrade and the Factory Upgrade) in firmware update.

User Upgrade	Upgrade the firmware only. The setting values are not initialized.
Factory Upgrade (Firmware upgrade)	Upgrade the firmware and initialize the setting values.
Factory Upgrade (Flash upgrade)	Upgrade the firmware and initialize the setting values along with the setting data adjusted at the factory such as White Balance, etc.

The identification of User Upgrade and Factory Upgrade are done by the filename.

- Turn the power off and unplug the AC Cord.
- Insert the USB storage device to the USB port as shown below.

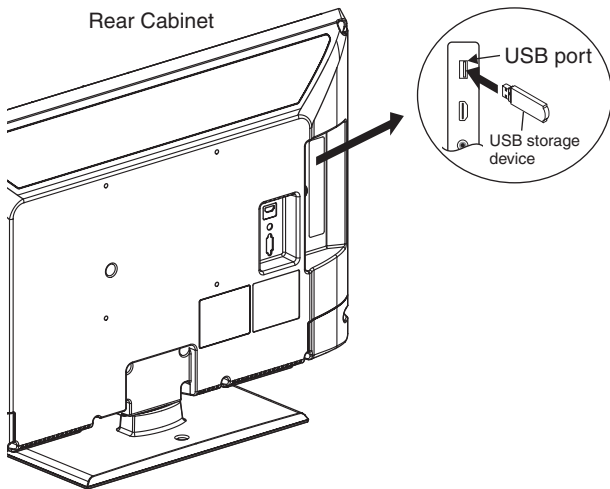

- Plug the AC cord in the wall outlet and turn the power on.

- The update will start and the following will appear on the screen.

*" differs depending on the models.

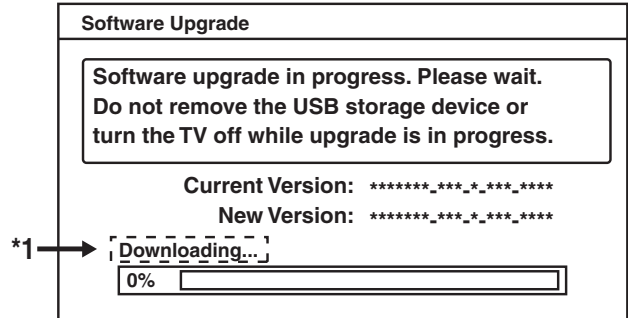

Note: If the above screen isn't displayed, repeat from step 1.

The appearance shown in *1 is described as follows.

Appearance	State
Downloading...	Downloading the firmware from the USB storage device.
Writing...	Writing the downloaded firmware in flash memory.
Checking...	Checking the new firmware.

- When the firmware update is completed, the following will appear on the screen.

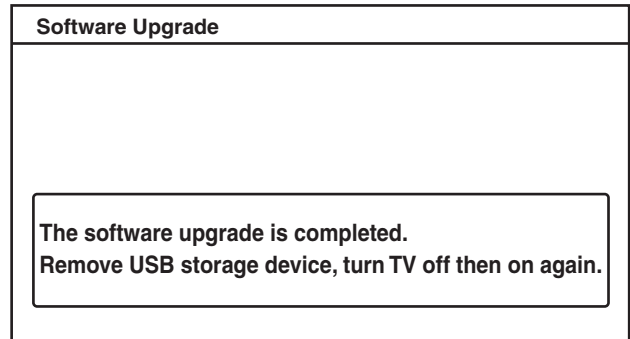

Remove the USB storage device from the USB port.

Turn the power off and turn the power on again.

Note:

When the Factory Upgrade is used, after restarting TV, shift to initial screen menu in service mode. "INITIALIZED" will appear on the upper right of the screen. "INITIALIZED" color will change to green from red when initializing is completed.

TROUBLESHOOTING

[Power Supply Section]

FLOW CHART NO.1

The power cannot be turned on.

Is the fuse (F601) normal?

No

See FLOW CHART No.2 <The fuse blows out.>

Yes

Is normal state restored when once unplugged power cord is plugged again after several seconds?

No

Check if there is any leak or short-circuiting on the primary circuit component, and service it if defective. (D600, D601, D602, D603, Q600, Q601, T600)

Yes

Is the P-ON+24V line voltage normal?

No

Yes

Check each rectifying circuit of the secondary circuit and service it if defective.

FLOW CHART NO.2

The fuse blows out.

Check the presence that the primary component is leaking or shorted and service it if defective.

Check the presence that the rectifying diode or circuit is shorted in each rectifying circuit of secondary side, and service it if defective.

After servicing, replace the fuse.

FLOW CHART NO.3

When the output voltage fluctuates.

Does the photocoupler circuit on the secondary side operate normally?

No

Check IC601, D648, Q631, Q634 and their periphery circuit, and service it if defective.

Yes

Check IC601, D607, D609 and their periphery circuit, and service it if defective.

FLOW CHART NO.4

When buzz sound can be heard in the vicinity of power circuit.

Check if there is any short-circuit on the rectifying diode and the circuit in each rectifying circuit of the secondary side, and service it if defective. (IC202, Q212, Q213, Q221, Q222, Q636, D634, D637, D642, D643, D644, D646, D660)

FLOW CHART NO.5

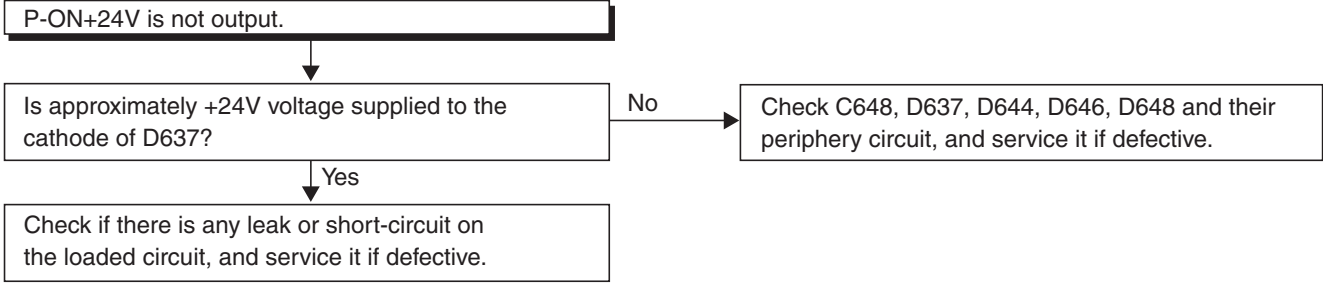

FLOW CHART NO.6

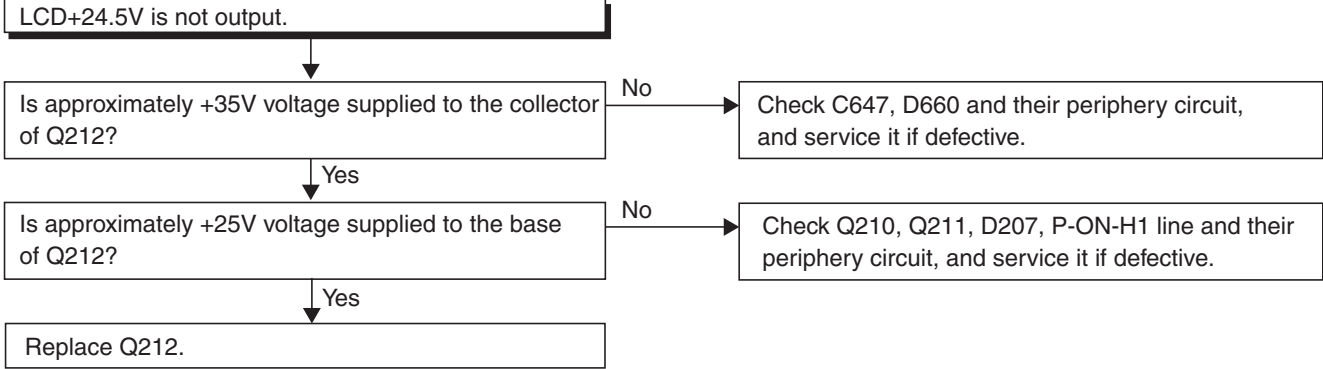

FLOW CHART NO.7

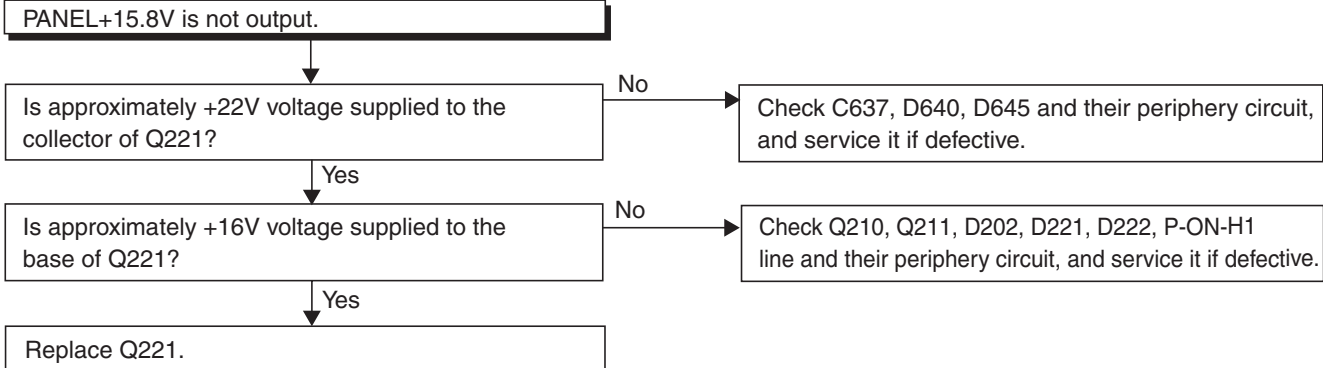

FLOW CHART NO.8

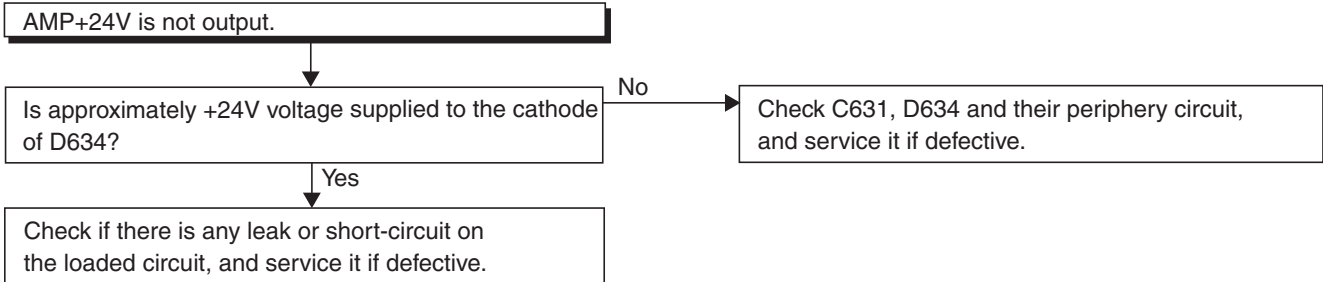

FLOW CHART NO.9

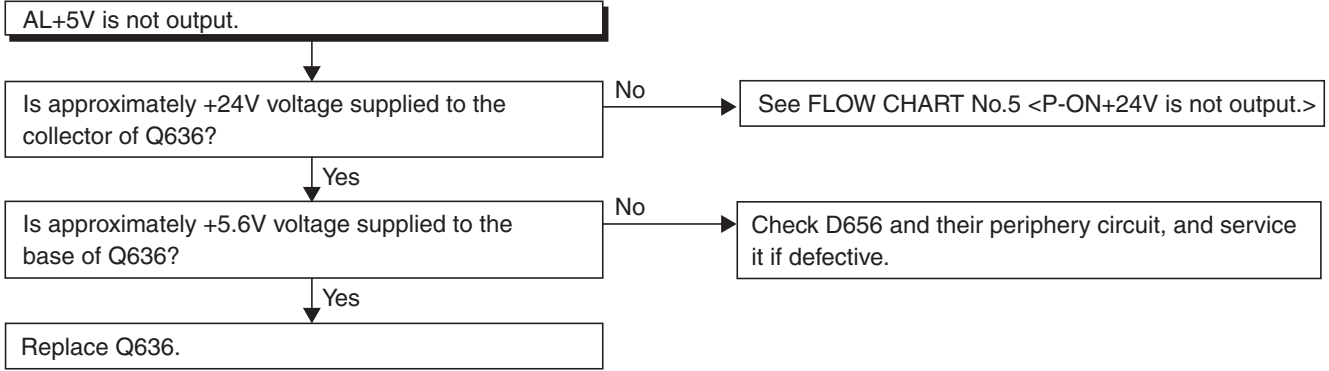

FLOW CHART NO.10

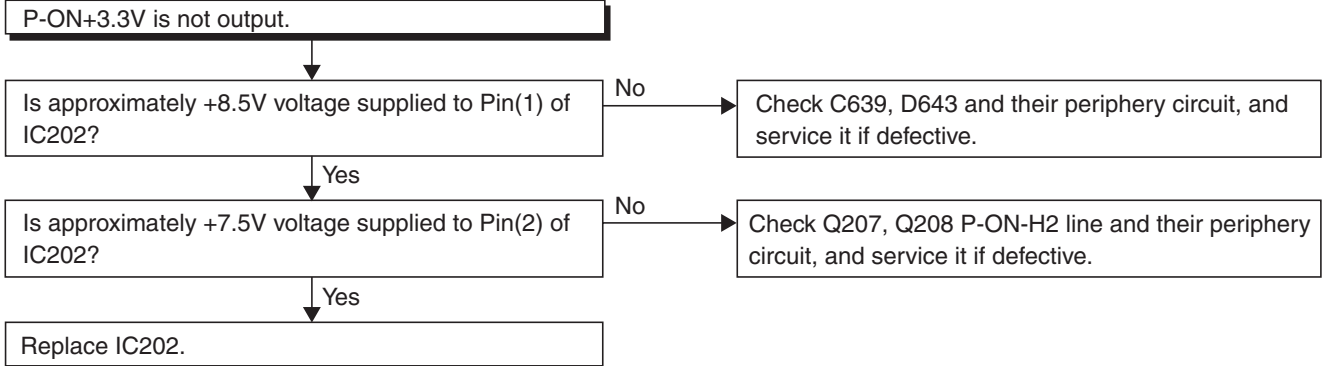

FLOW CHART NO.11

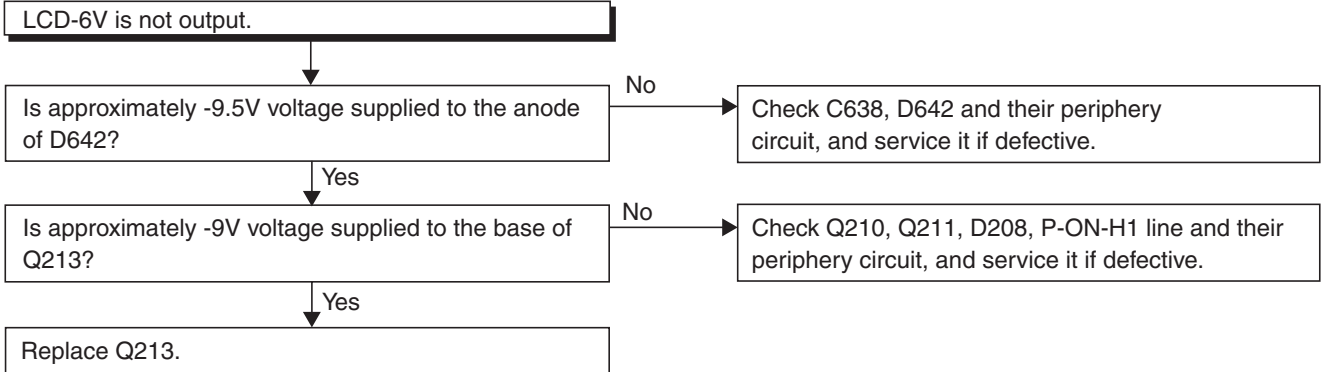

[Video Signal Section]

FLOW CHART NO.1

The key operation is not functioning.

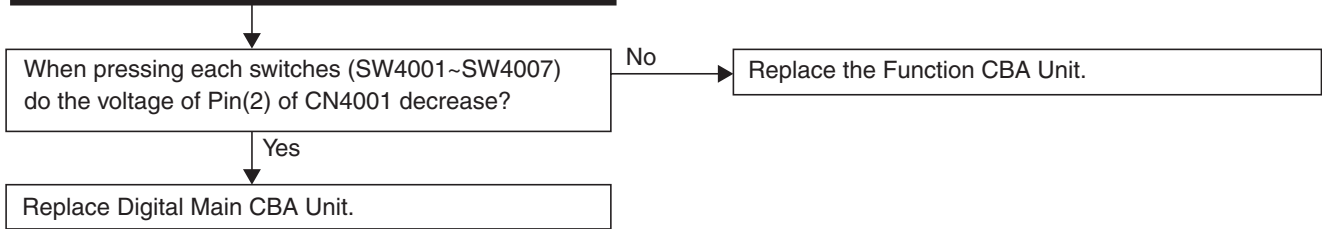

FLOW CHART NO.2

No operation is possible from the remote control unit.

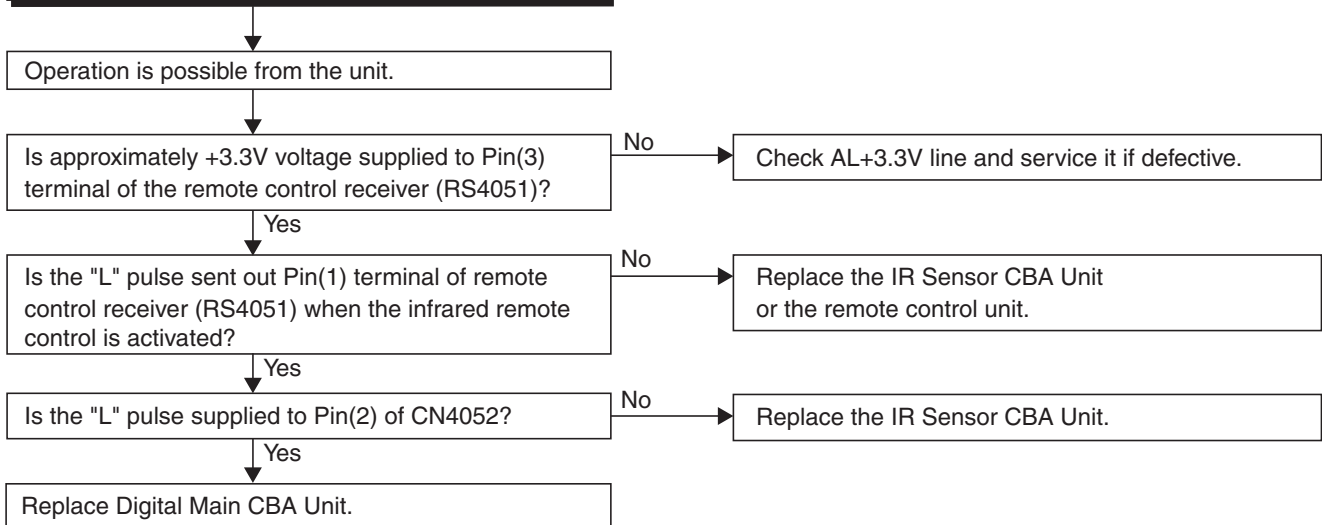

FLOW CHART NO.3

Picture does not appear normally.

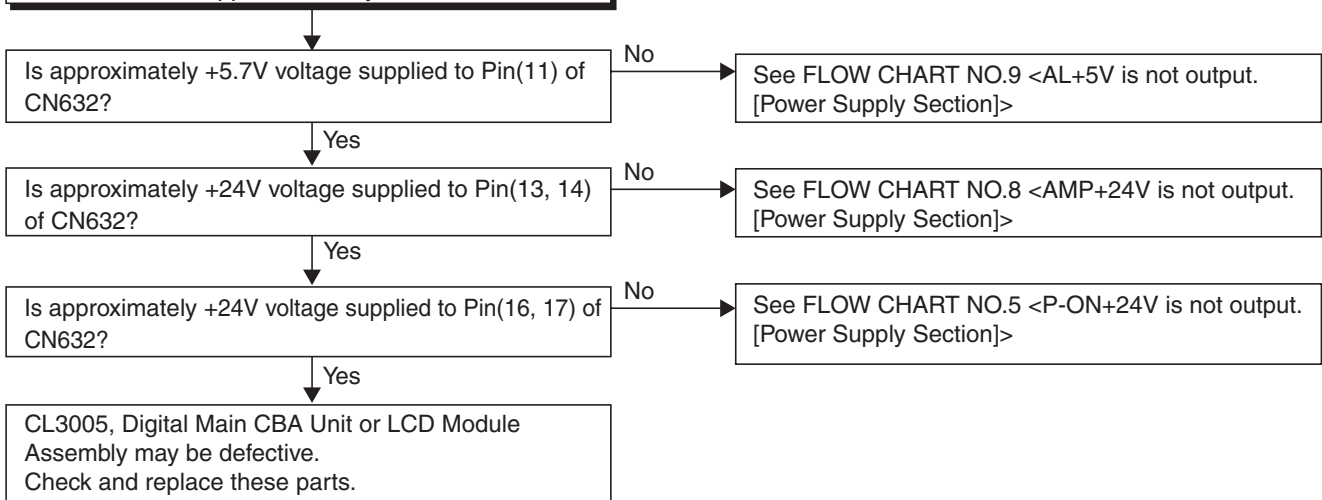

[Audio Signal Section]

FLOW CHART NO.1

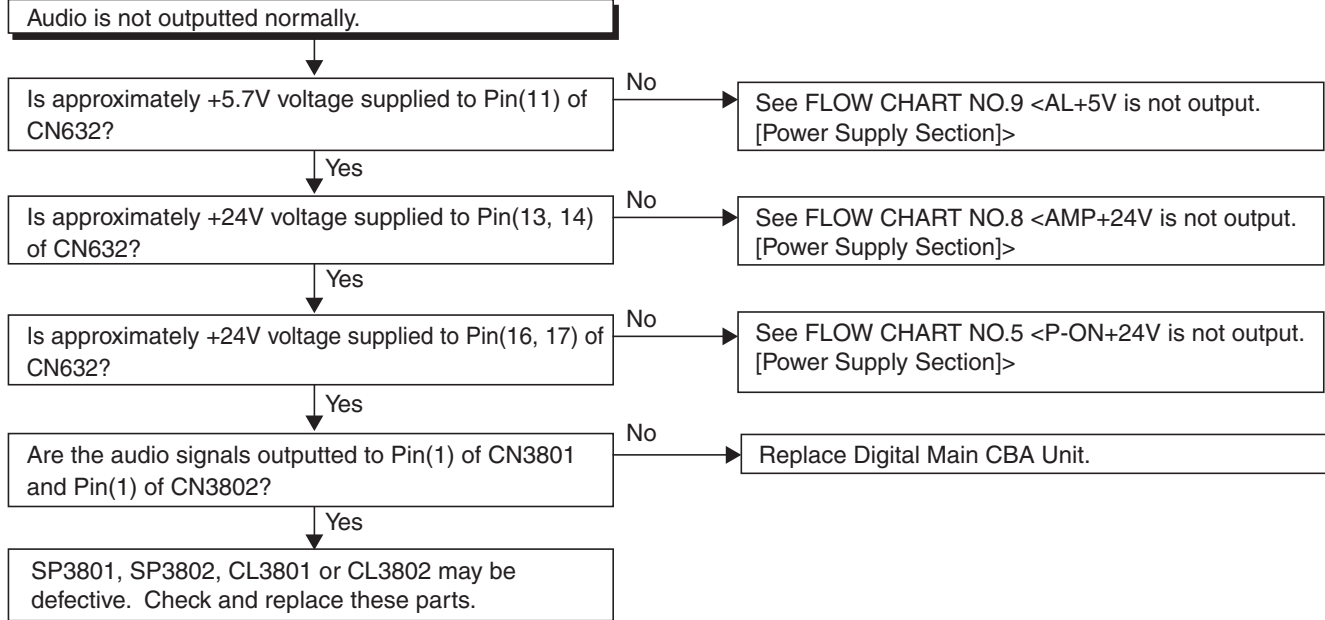

BLOCK DIAGRAMS

1. System Control Block Diagram

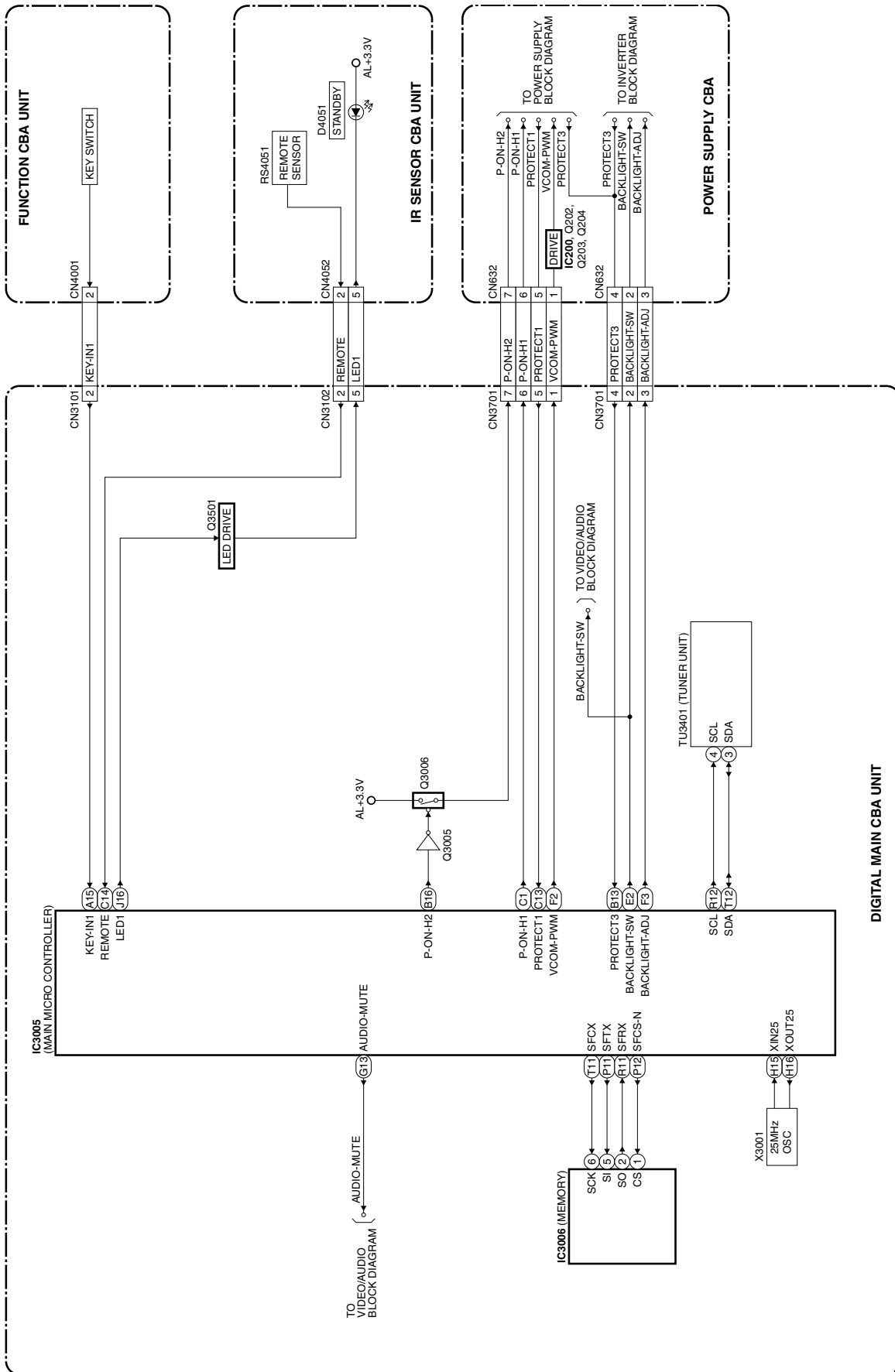

2. Video/Audio Block Diagram

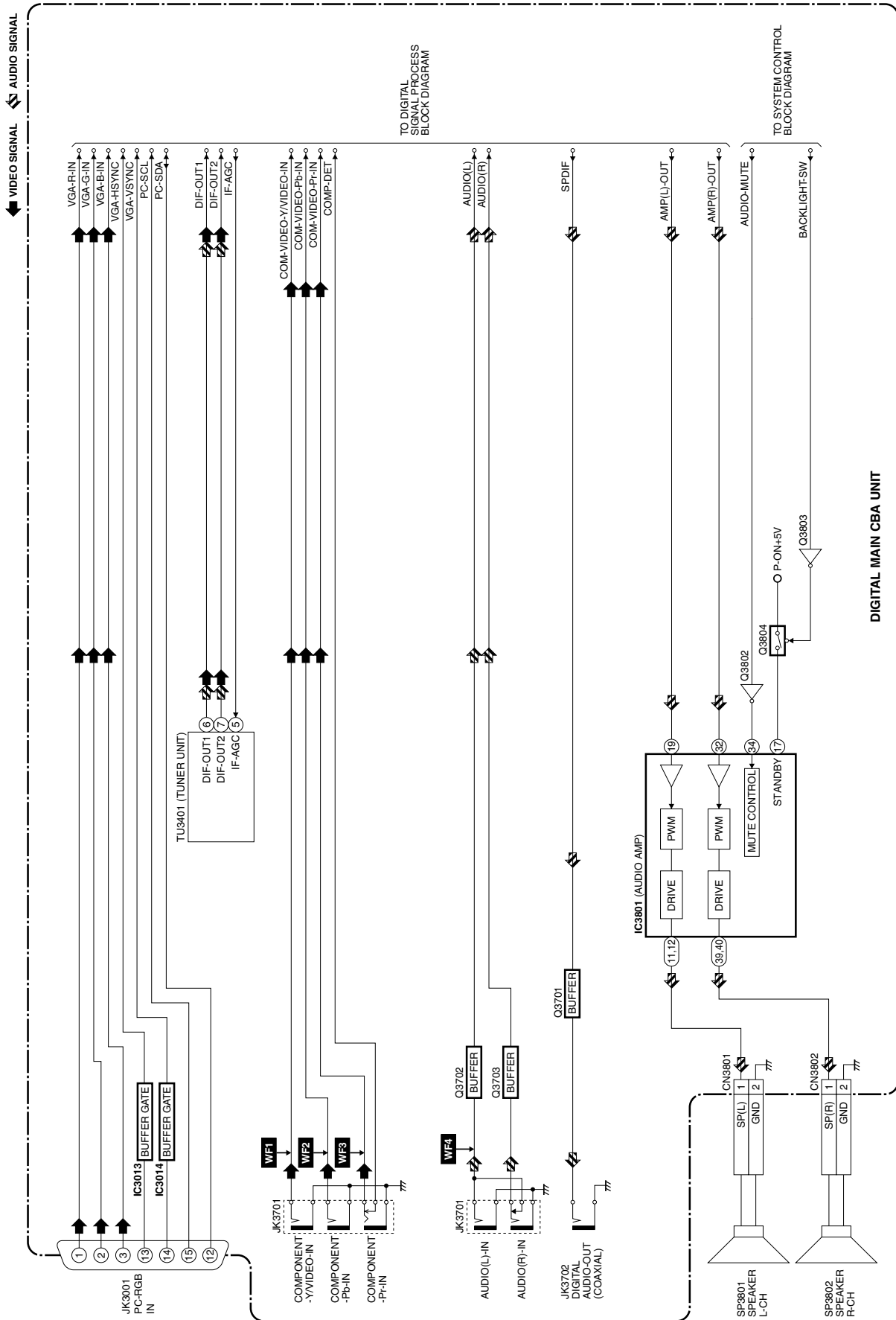

3. Digital Signal Process Block Diagram

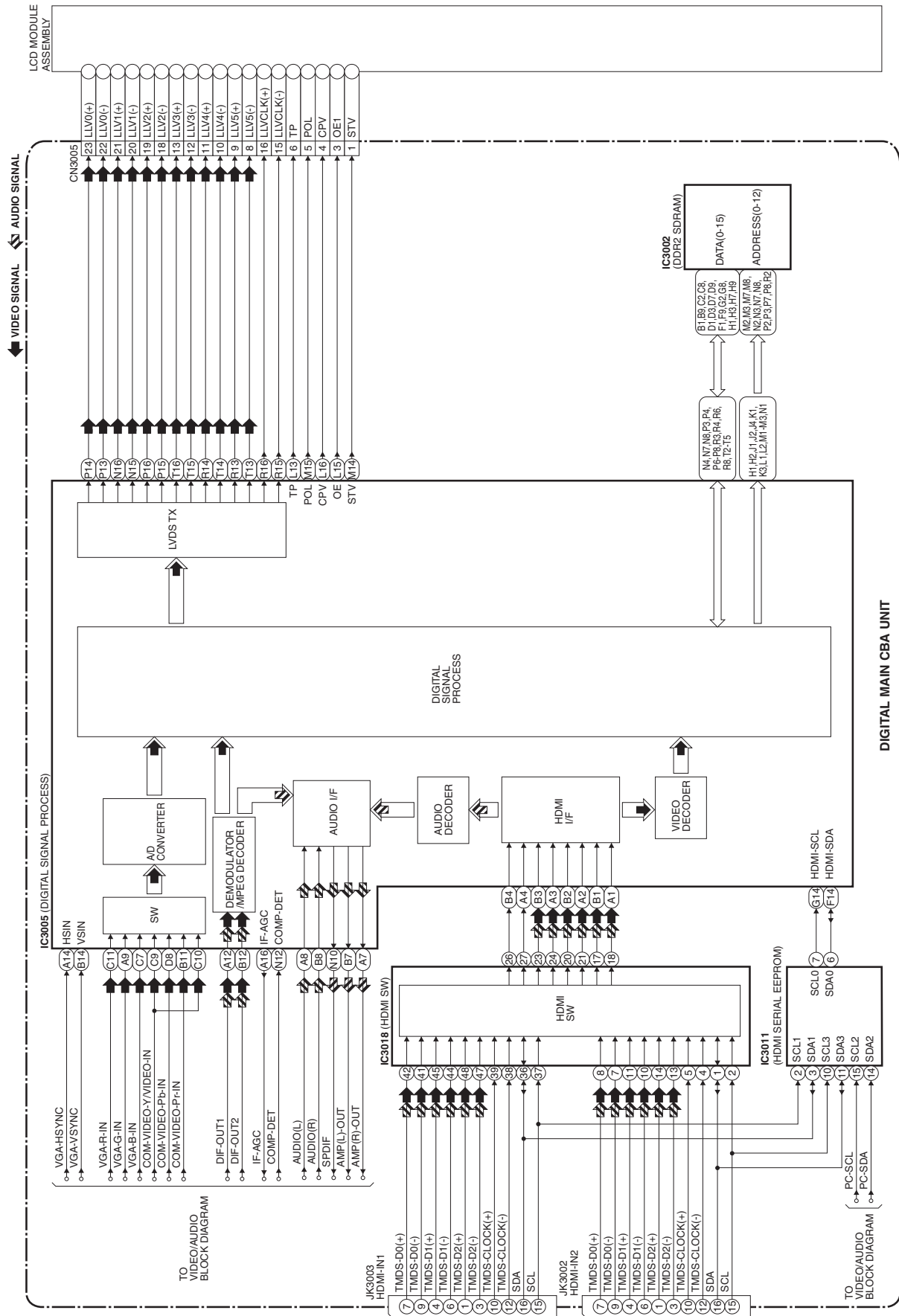

4. Inverter Block Diagram

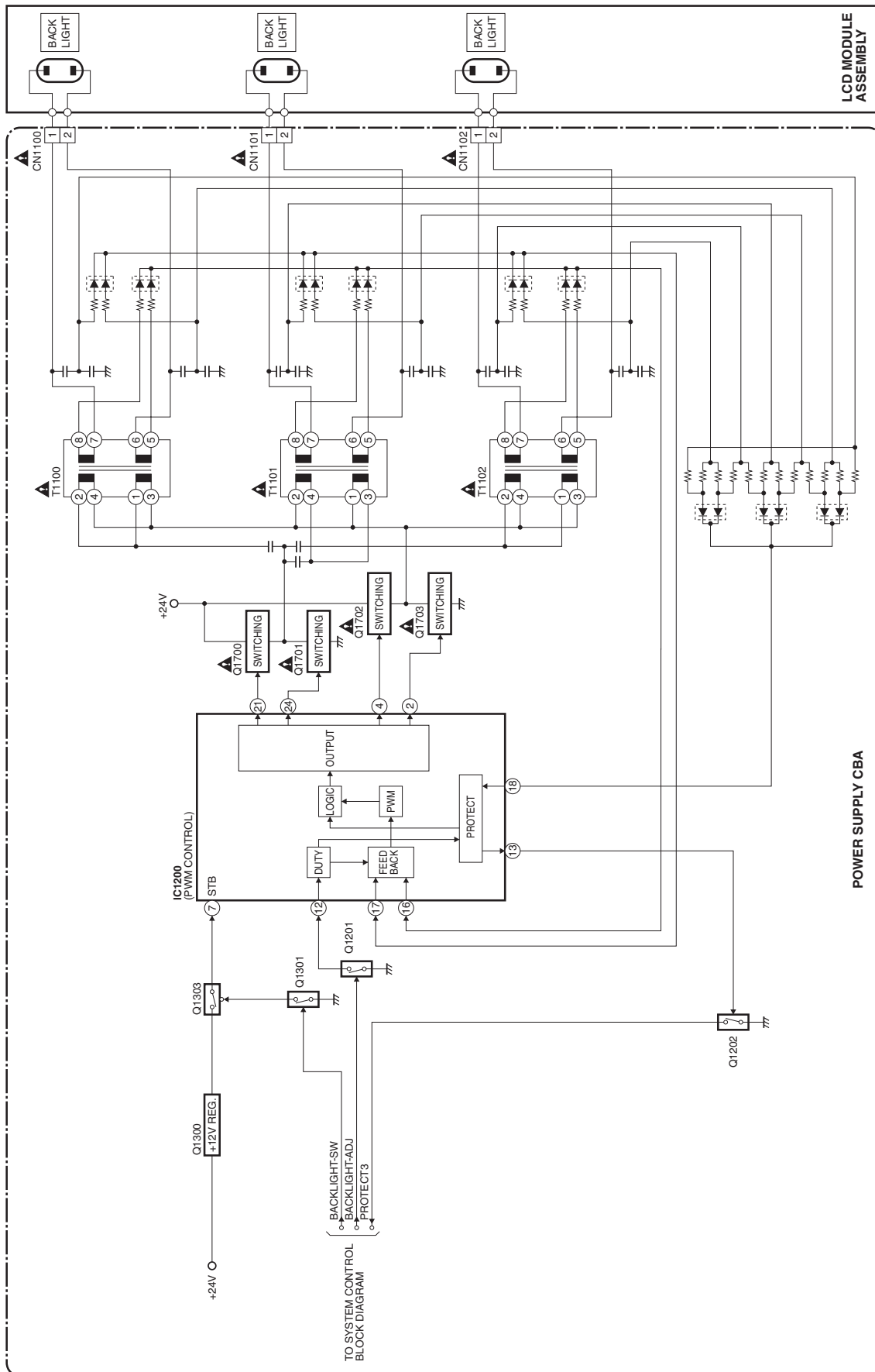

5. Power Supply Block Diagram

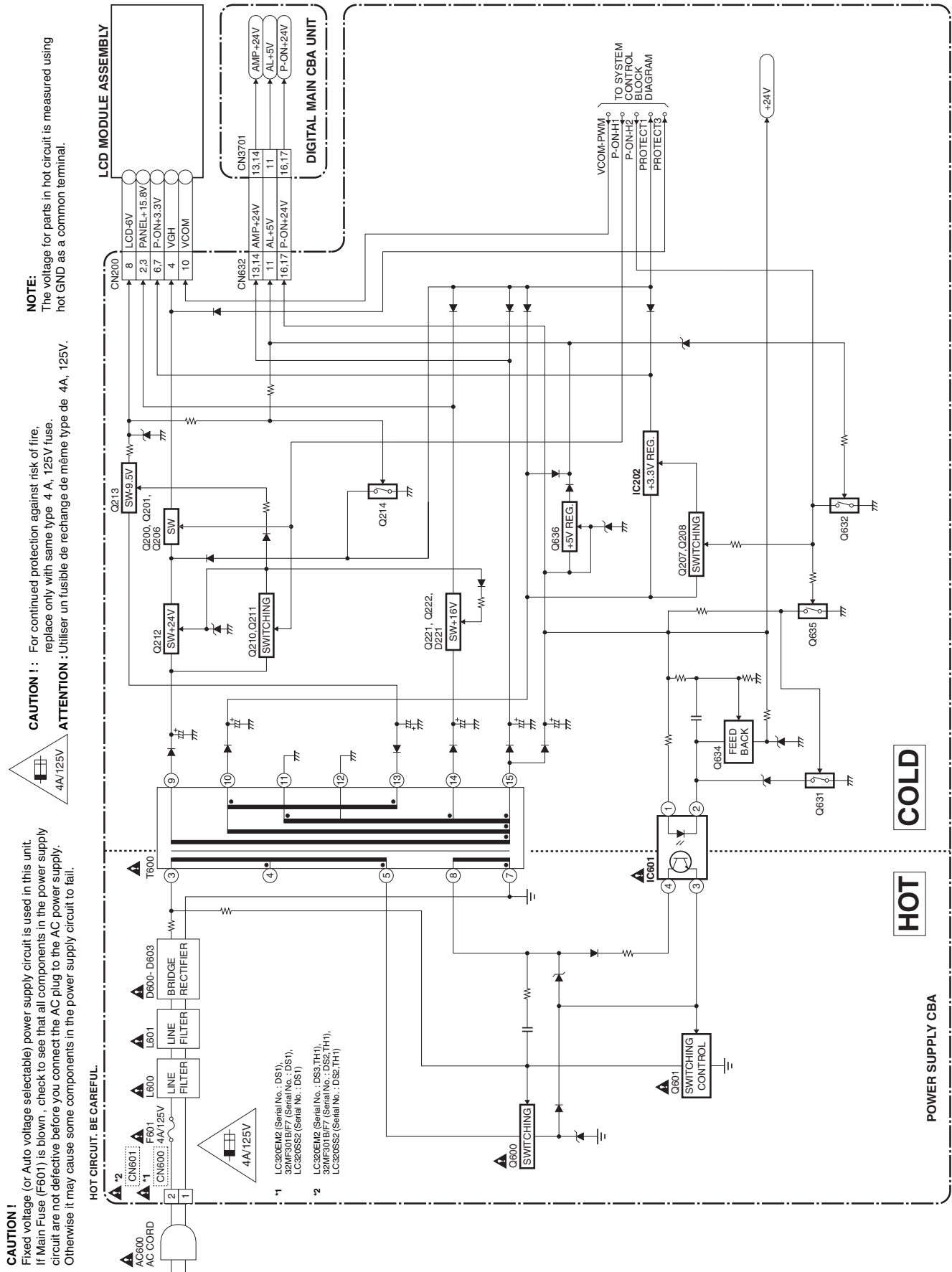

SCHEMATIC DIAGRAMS / CBA AND TEST POINTS

Standard Notes

WARNING

Many electrical and mechanical parts in this chassis have special characteristics. These characteristics often pass unnoticed and the protection afforded by them cannot necessarily be obtained by using replacement components rated for higher voltage, wattage, etc. Replacement parts that have these special safety characteristics are identified in this manual and its supplements; electrical components having such features are identified by the mark “▲” in the schematic diagram and the parts list. Before replacing any of these components, read the parts list in this manual carefully. The use of substitute replacement parts that do not have the same safety characteristics as specified in the parts list may create shock, fire, or other hazards.

Notes:

1. Do not use the part number shown on these drawings for ordering. The correct part number is shown in the parts list, and may be slightly different or amended since these drawings were prepared.
2. All resistance values are indicated in ohms ($K = 10^3$, $M = 10^6$).
3. Resistor wattages are 1/4W or 1/6W unless otherwise specified.
4. All capacitance values are indicated in μF ($P = 10^{-6} \mu F$).
5. All voltages are DC voltages unless otherwise specified.
6. This schematic diagrams are masterized version that should cover the entire FL11.4 chassis models. Thus some parts in detail illustrated on this schematic diagrams may vary depend on the model within the FL11.4 chassis. Please refer to the parts lists for each models.
7. The Circuit Board layout illustrated on this service manual is the latest version for this chassis at the moment of making this service manual. Depend on the mass production date of each model, the actual layout of each Board may differ slightly from this version.

LIST OF CAUTION, NOTES, AND SYMBOLS USED IN THE SCHEMATIC DIAGRAMS ON THE FOLLOWING PAGES:

1. CAUTION:

CAUTION: FOR CONTINUED PROTECTION AGAINST RISK OF FIRE, REPLACE ONLY WITH SAME TYPE_A,_V FUSE.

ATTENTION: UTILISER UN FUSIBLE DE RECHANGE DE MÊME TYPE DE_A,_V.

2. CAUTION:

Fixed Voltage (or Auto voltage selectable) power supply circuit is used in this unit.

If Main Fuse (F601) is blown, first check to see that all components in the power supply circuit are not defective before you connect the AC plug to the AC power supply. Otherwise it may cause some components in the power supply circuit to fail.

3. Note:

- Do not use the part number shown on the drawings for ordering. The correct part number is shown in the parts list, and may be slightly different or amended since the drawings were prepared.
- To maintain original function and reliability of repaired units, use only original replacement parts which are listed with their part numbers in the parts list section of the service manual.

4. Voltage indications on the schematics are as shown below:

Plug the TV power cord into a standard AC outlet.:

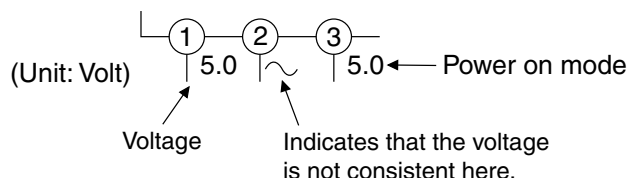

5. How to read converged lines

1-D3

↑ Distinction Area
↑ Line Number
(1 to 3 digits)

Examples:

- "1-D3" means that line number "1" goes to the line number "1" of the area "D3".
- "1-B1" means that line number "1" goes to the line number "1" of the area "B1".

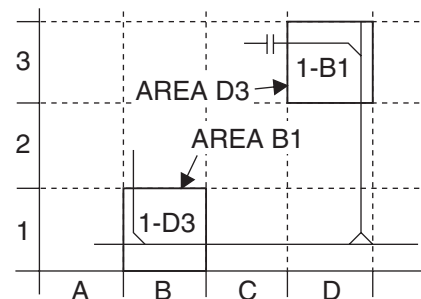

6. Test Point Information

⊕ : Indicates a test point with a jumper wire across a hole in the PCB.

□→ : Used to indicate a test point with a component lead on foil side.

⊘ : Used to indicate a test point with no test pin.

● : Used to indicate a test point with a test pin.

The reference number of parts on Schematic Diagrams/CBA can be retrieved by application search function.

Power Supply 1 Schematic Diagram

CAUTION !

Fixed voltage (or Auto voltage selectable) power supply circuit is used in this unit.
If Main Fuse (F601) is blown, check to see that all components in the power supply circuit are not defective before you connect the AC plug to the AC power supply.
Otherwise it may cause some components in the power supply circuit to fail.

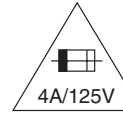

CAUTION ! : For continued protection against risk of fire, replace only with same type 4 A, 125V fuse.
ATTENTION : Utiliser un fusible de rechange de même type de 4A, 125V.

NOTE:

The voltage for parts in hot circuit is measured using hot GND as a common terminal.

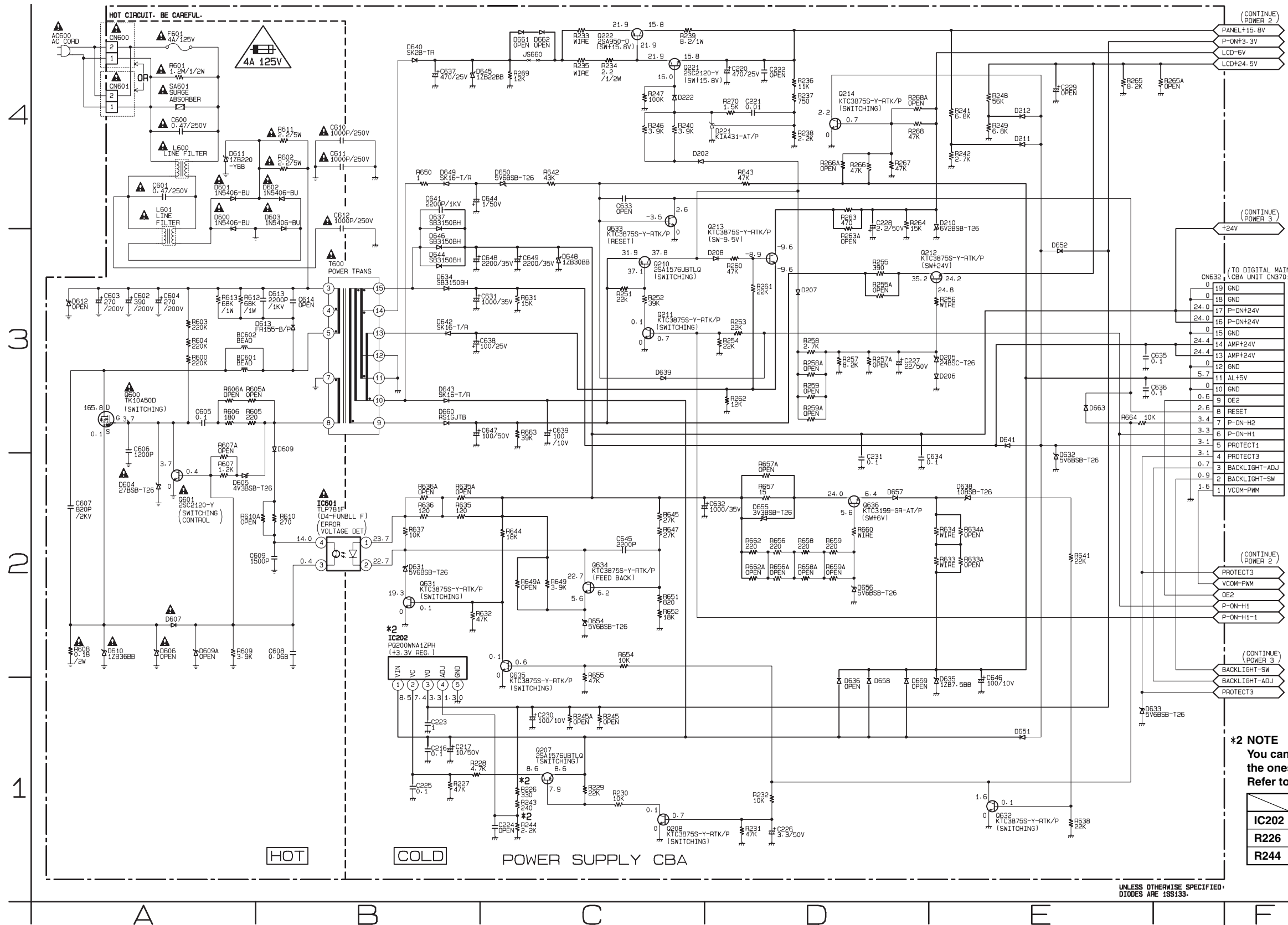

***2 NOTE**
You cannot mix components under Type 1 with the ones under Type 2.
Refer to Parts List of LC320EM2(Serial No.: DS1).

	Type 1	Type 2
IC202	KIA78R000ZF-RTF/P	PQ200WNA1ZPH
R226	1.4k Ω	330 Ω
R244	1k Ω	2.2k Ω

UNLESS OTHERWISE SPECIFIED, DIODES ARE 1SS133.

Power Supply 2 Schematic Diagram

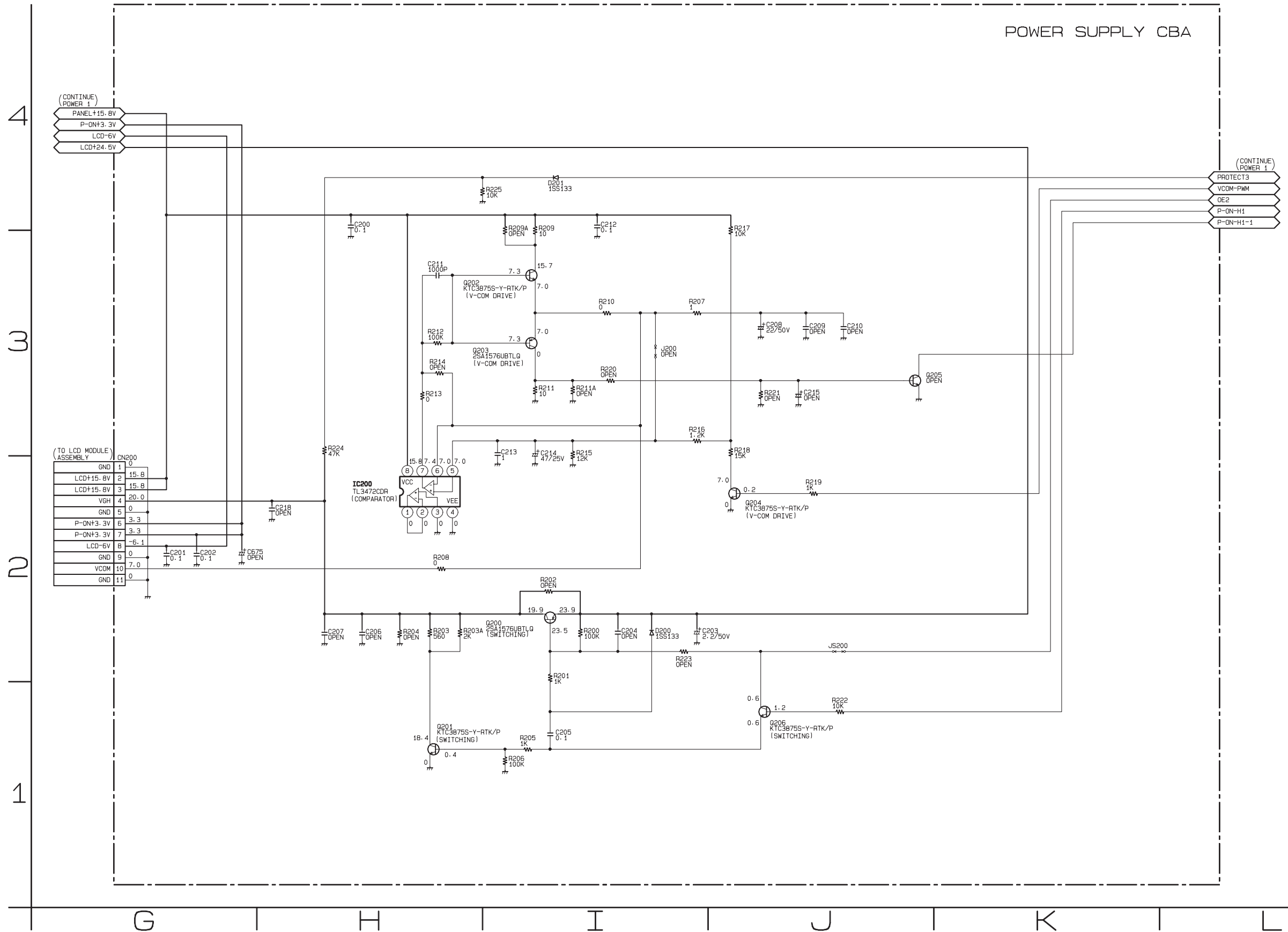

Power Supply 3 Schematic Diagram

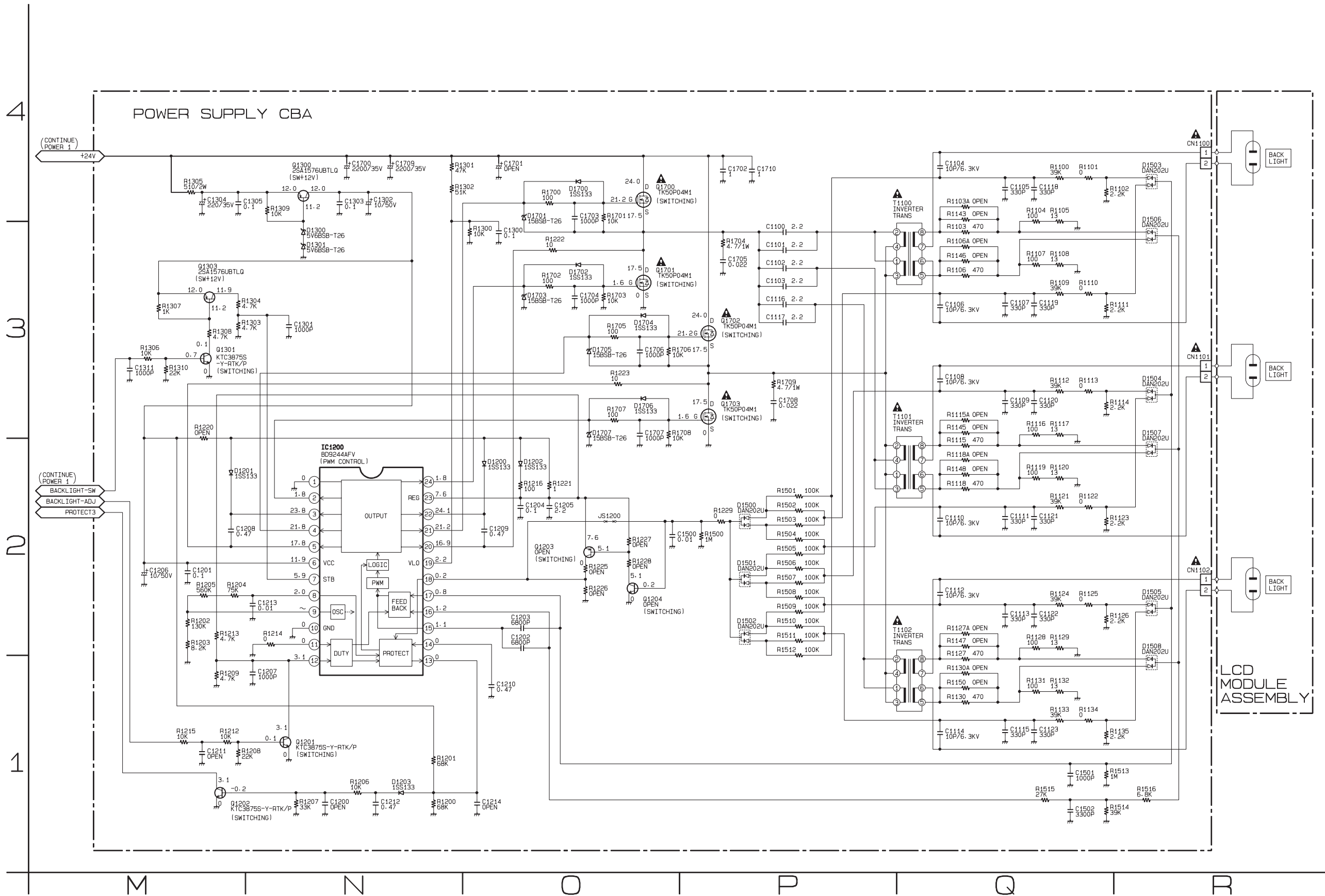

Function Schematic Diagram

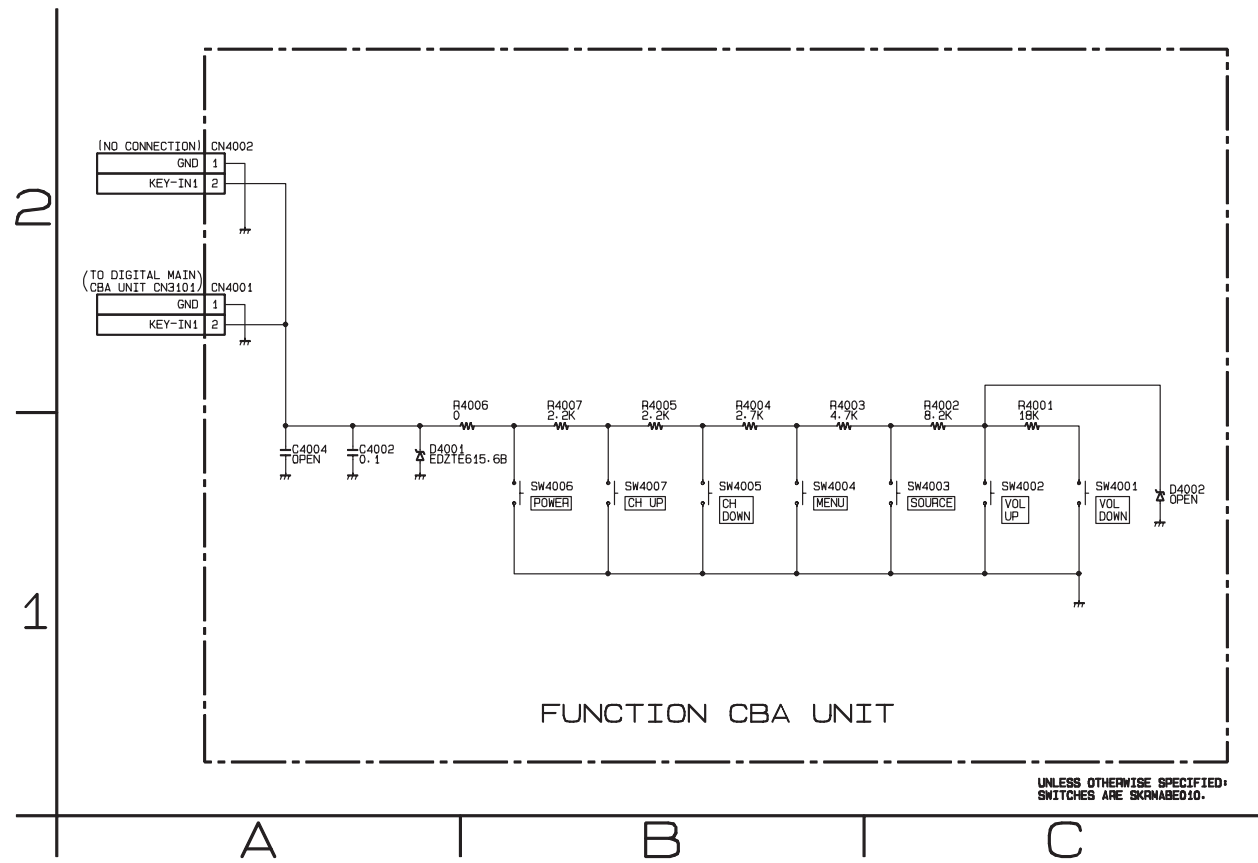

IR Sensor Schematic Diagram

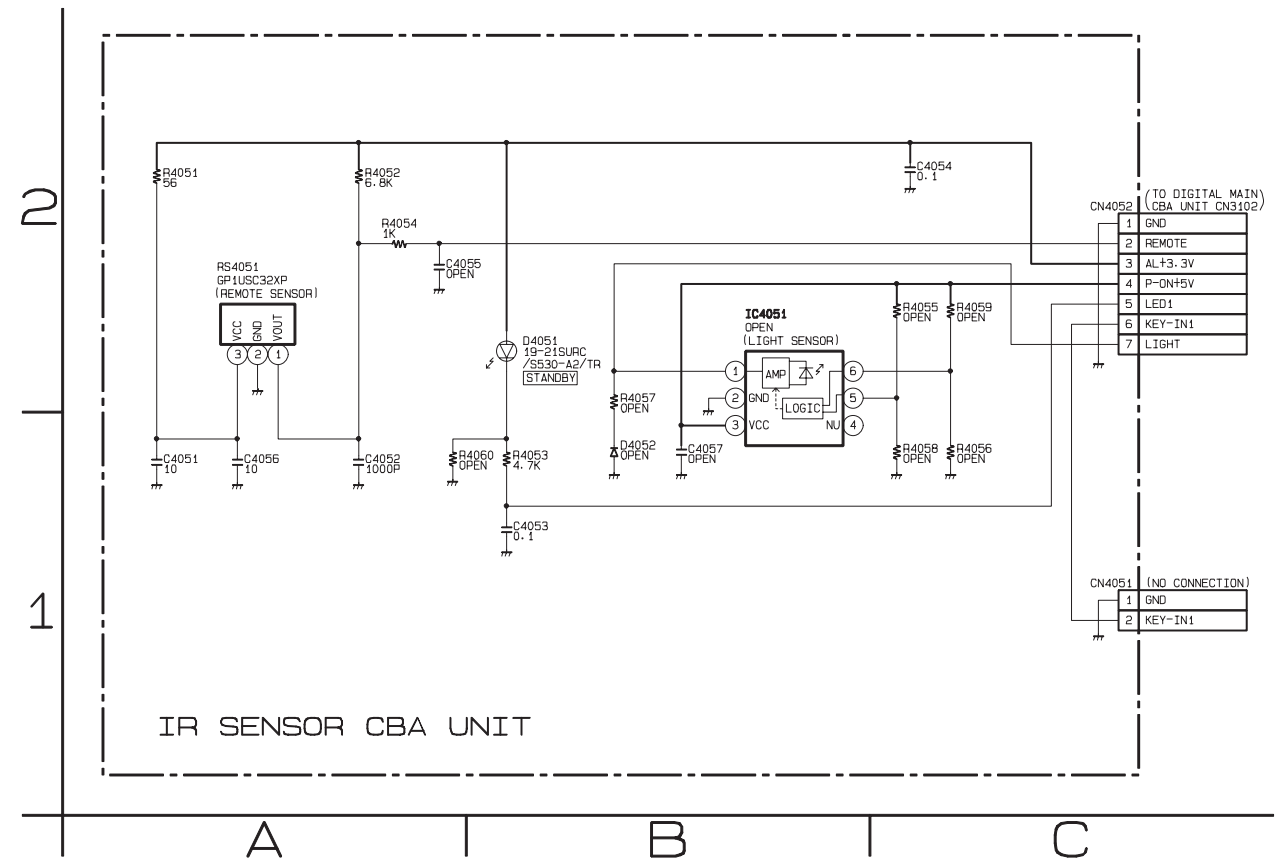

Digital Main 1 Schematic Diagram

*1 NOTE:
 The order of pins shown in this diagram is different from that of actual IC3005.
 IC3005 is divided into six and shown as IC3005 (1/6) ~ IC3005 (6/6) in this Digital Main Schematic Diagram Section.

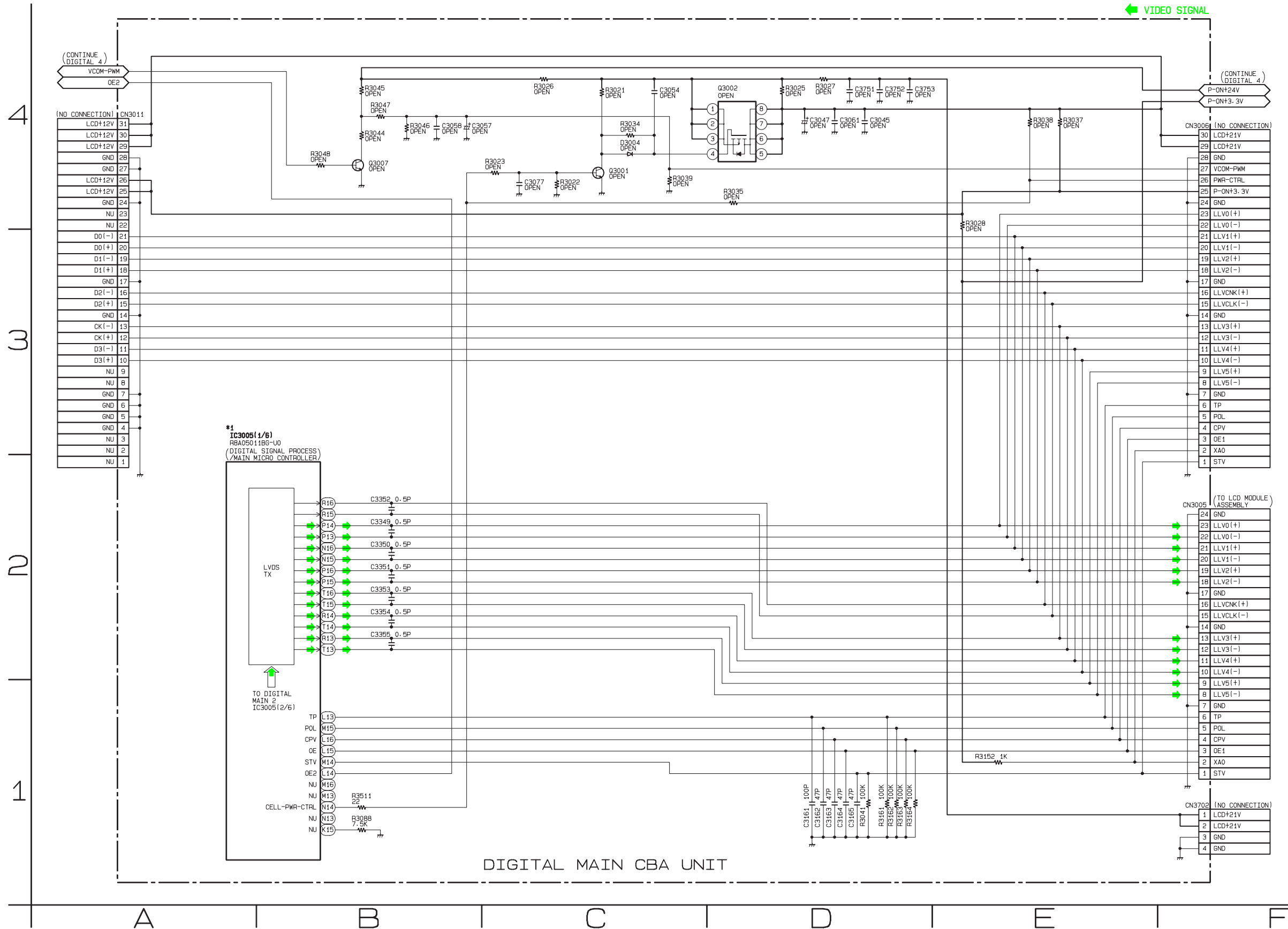

Digital Main 2 Schematic Diagram

*1 NOTE:

The order of pins shown in this diagram is different from that of actual IC3005.

IC3005 is divided into six and shown as IC3005 (1/6) ~ IC3005 (6/6) in this Digital Main Schematic Diagram Section.

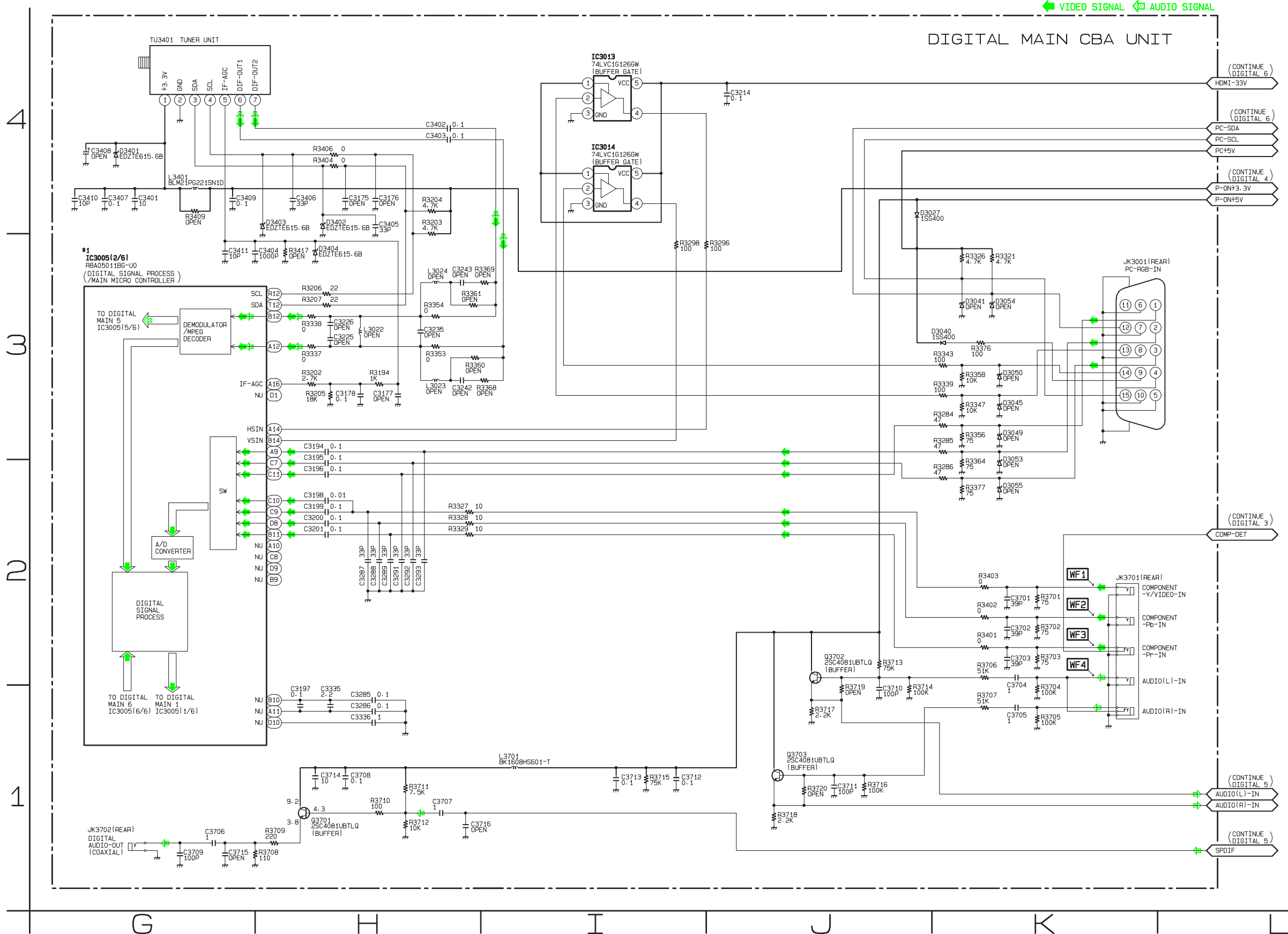

Digital Main 3 Schematic Diagram

***1 NOTE:**

The order of pins shown in this diagram is different from that of actual IC3005.

IC3005 is divided into six and shown as IC3005 (1/6) ~ IC3005 (6/6) in this Digital Main Schematic Diagram Section.

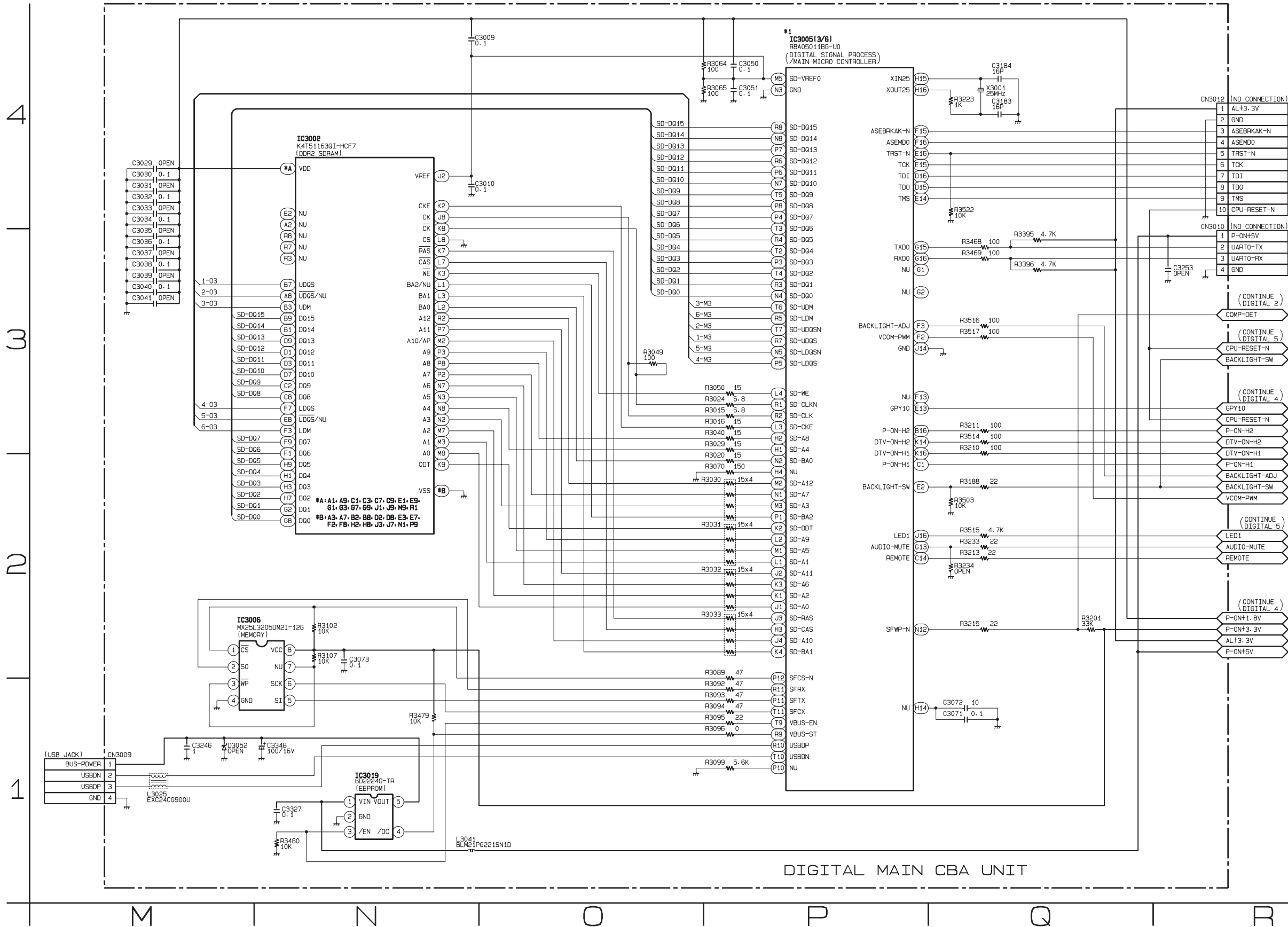

Digital Main 4 Schematic Diagram

***1 NOTE:**

The order of pins shown in this diagram is different from that of actual IC3005.
IC3005 is divided into six and shown as IC3005 (1/6) ~ IC3005 (6/6) in this Digital Main Schematic Diagram Section.

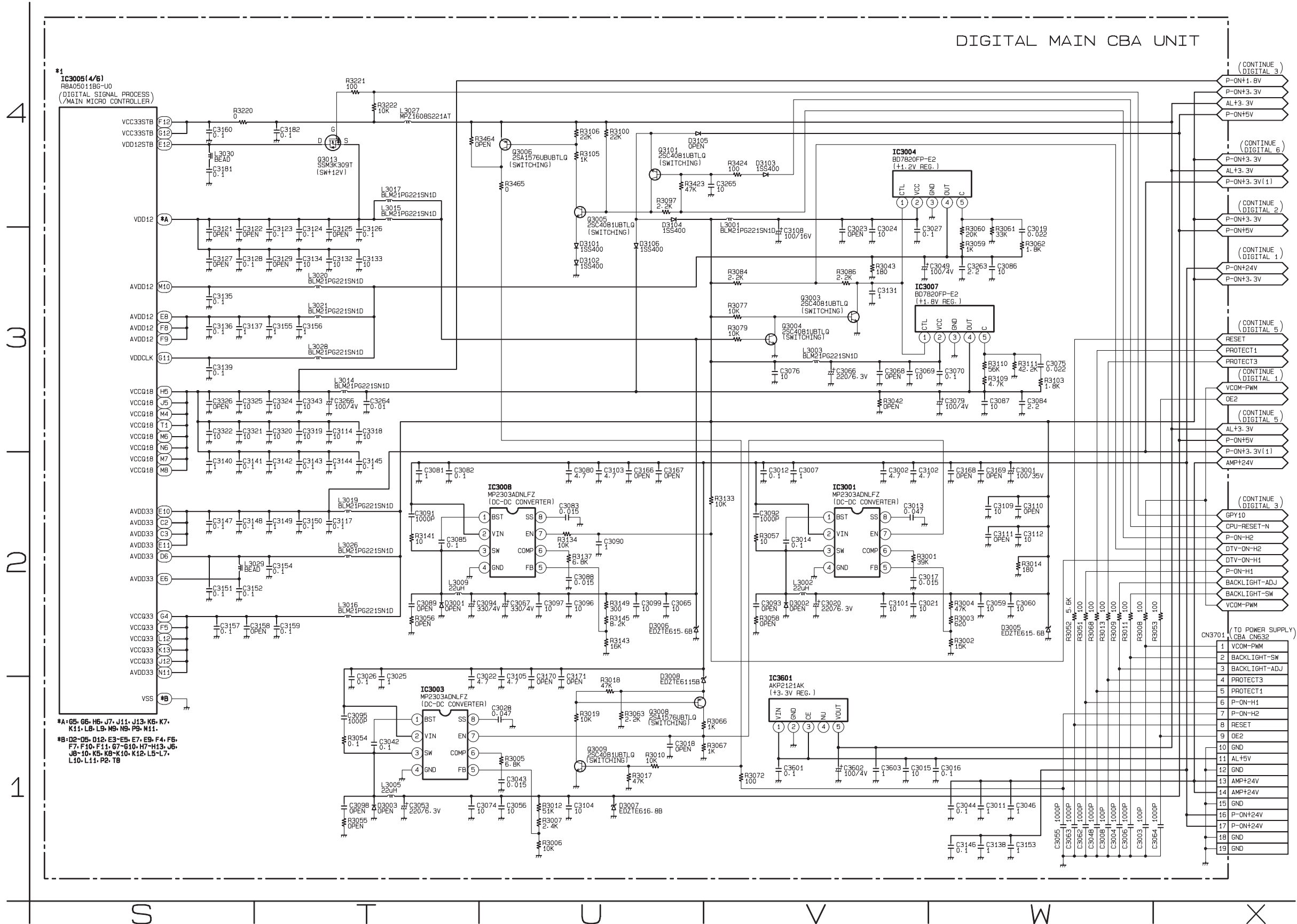

Digital Main 6 Schematic Diagram

*1 NOTE:

The order of pins shown in this diagram is different from that of actual IC3005.
IC3005 is divided into six and shown as IC3005 (1/6) ~ IC3005 (6/6) in this Digital Main Schematic Diagram Section.

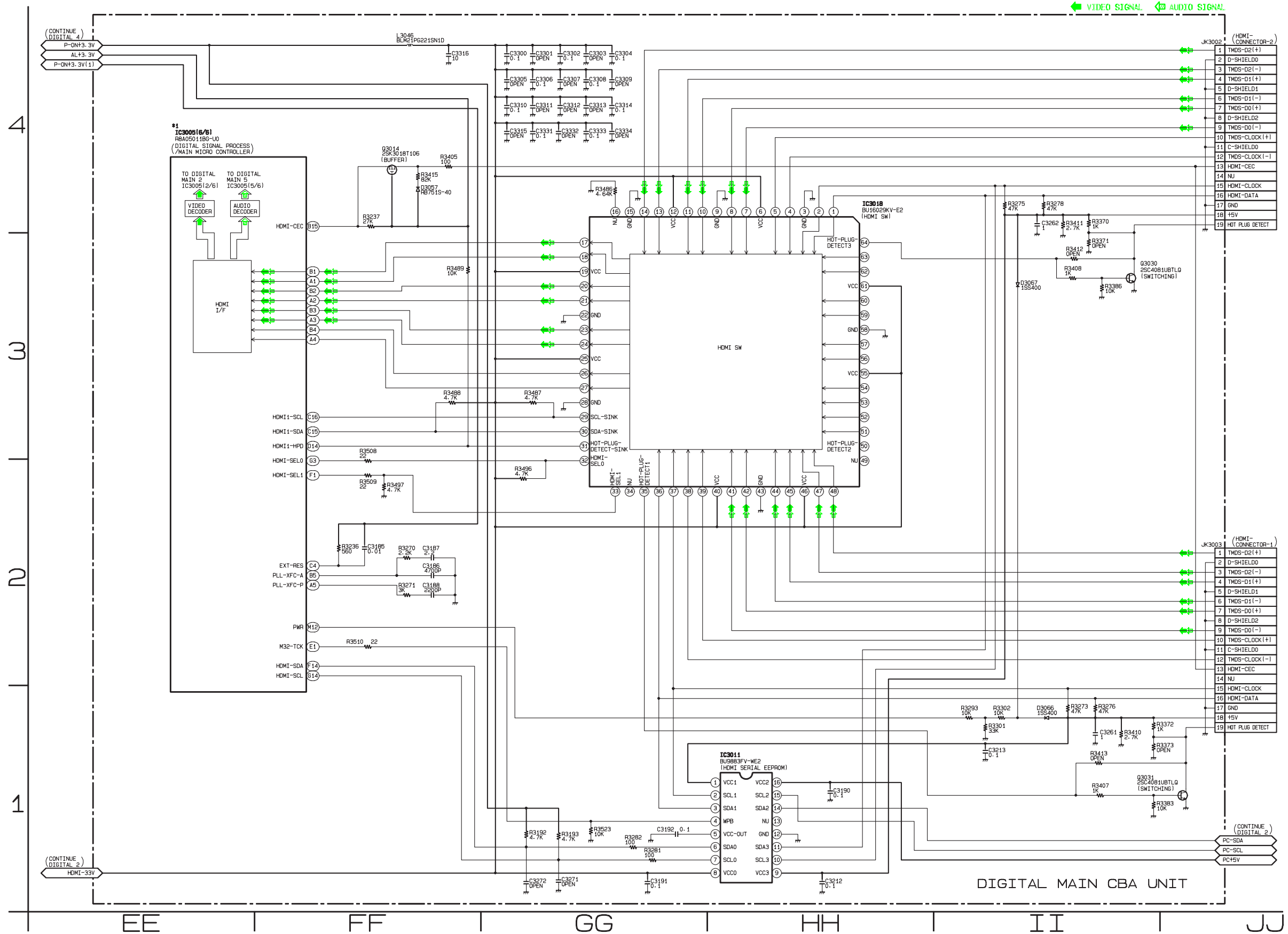

Power Supply CBA Top View [TYPE A]

CAUTION !

Fixed voltage (or Auto voltage selectable) power supply circuit is used in this unit. If Main Fuse (F601) is blown, check to see that all components in the power supply circuit are not defective before you connect the AC plug to the AC power supply. Otherwise it may cause some components in the power supply circuit to fail.

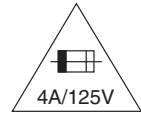

CAUTION ! : For continued protection against risk of fire, replace only with same type 4 A, 125V fuse.
ATTENTION : Utiliser un fusible de rechange de même type de 4A, 125V.

Because a hot chassis ground is present in the power supply circuit, an isolation transformer must be used when repairing. Also, in order to have the ability to increase the input slowly, when troubleshooting this type of power supply circuit, a variable isolation transformer is required.

NOTE:

The voltage for parts in hot circuit is measured using hot GND as a common terminal.

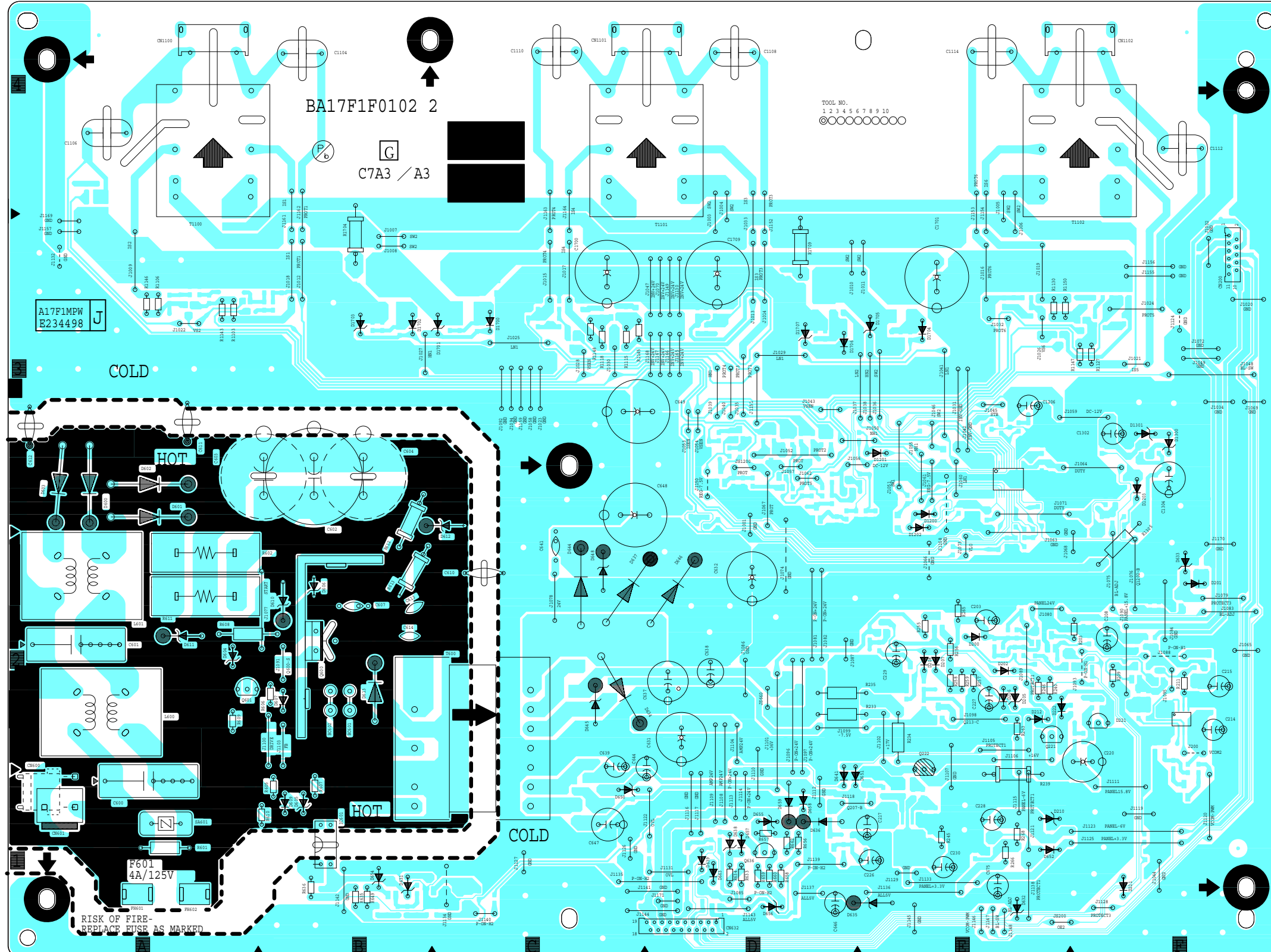

Power Supply CBA Bottom View [TYPE A]

CAUTION !

Fixed voltage (or Auto voltage selectable) power supply circuit is used in this unit.
 If Main Fuse (F601) is blown , check to see that all components in the power supply circuit are not defective before you connect the AC plug to the AC power supply.
 Otherwise it may cause some components in the power supply circuit to fail.

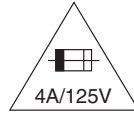

CAUTION ! : For continued protection against risk of fire,
 replace only with same type 4 A, 125V fuse.
ATTENTION : Utiliser un fusible de rechange de même type de 4A, 125V.

Because a hot chassis ground is present in the power supply circuit, an isolation transformer must be used when repairing.
 Also, in order to have the ability to increase the input slowly, when troubleshooting this type of power supply circuit, a variable isolation transformer is required.

NOTE:

The voltage for parts in hot circuit is measured using hot GND as a common terminal.

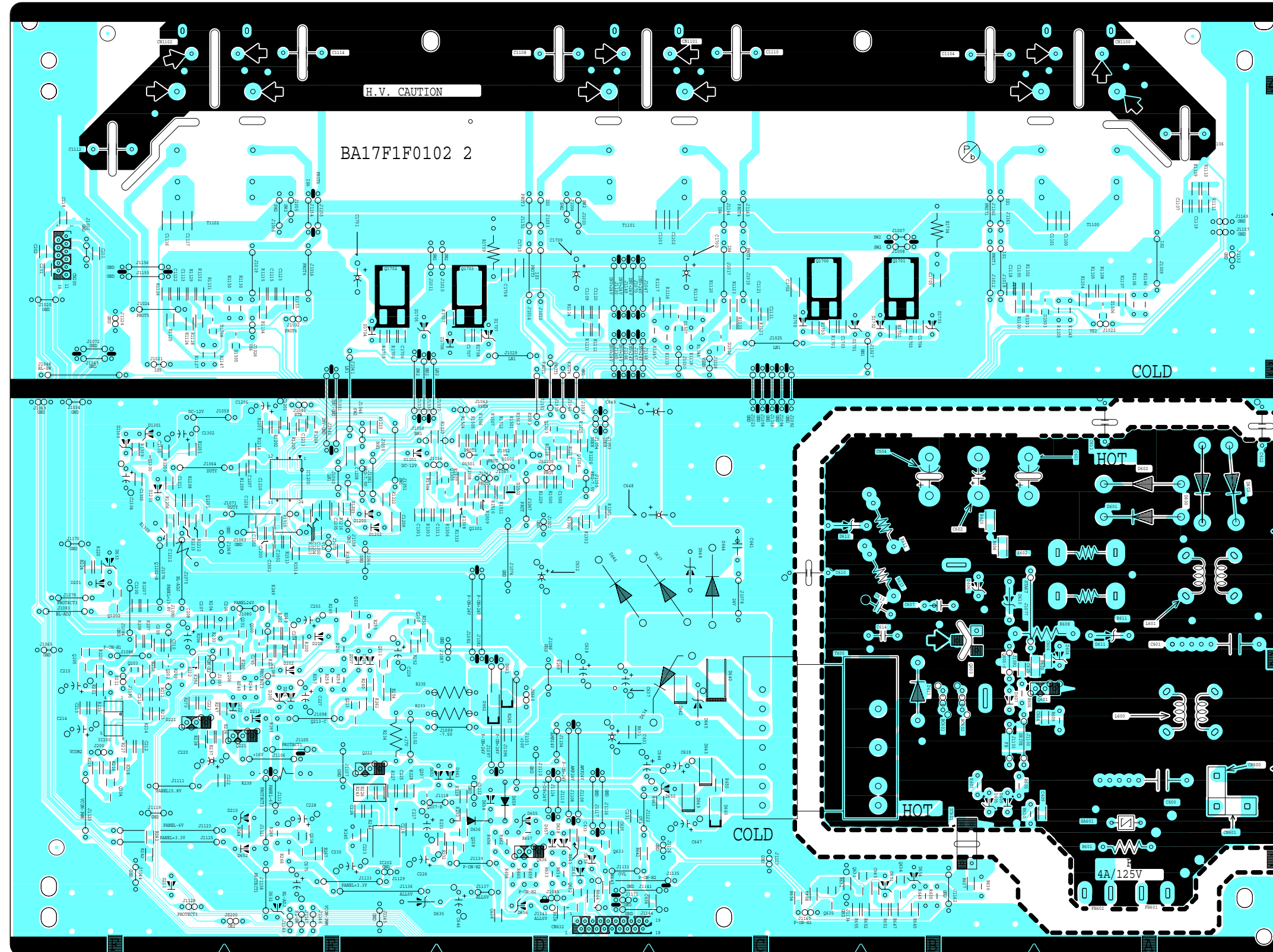

Power Supply CBA Top View [TYPE B]

CAUTION !

Fixed voltage (or Auto voltage selectable) power supply circuit is used in this unit.
If Main Fuse (F601) is blown, check to see that all components in the power supply circuit are not defective before you connect the AC plug to the AC power supply.
Otherwise it may cause some components in the power supply circuit to fail.

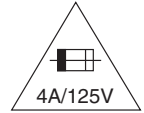

CAUTION ! : For continued protection against risk of fire, replace only with same type 4 A, 125V.
ATTENTION : Utiliser un fusible de rechange de même type de 4A, 125V.

Because a hot chassis ground is present in the power supply circuit, an isolation transformer must be used when repairing.
Also, in order to have the ability to increase the input slowly, when troubleshooting this type of power supply circuit, a variable isolation transformer is required.

NOTE:

The voltage for parts in hot circuit is measured using hot GND as a common terminal.

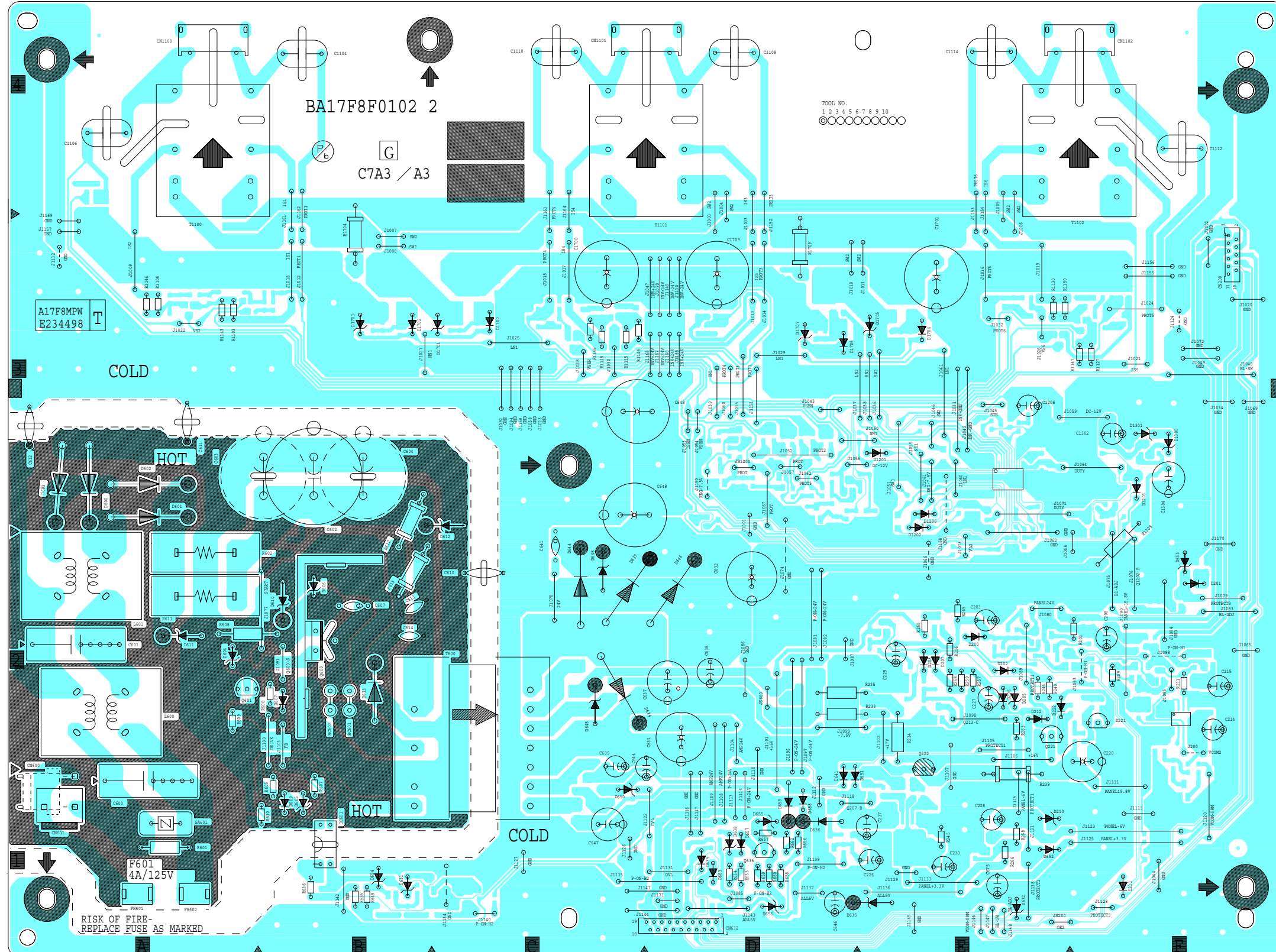

Power Supply CBA Bottom View [TYPE B]

CAUTION !

Fixed voltage (or Auto voltage selectable) power supply circuit is used in this unit.
 If Main Fuse (F601) is blown , check to see that all components in the power supply circuit are not defective before you connect the AC plug to the AC power supply.
 Otherwise it may cause some components in the power supply circuit to fail.

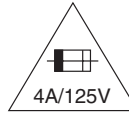

CAUTION ! : For continued protection against risk of fire, replace only with same type 4 A, 125V fuse.
ATTENTION : Utiliser un fusible de rechange de même type de 4A, 125V.

Because a hot chassis ground is present in the power supply circuit, an isolation transformer must be used when repairing.
 Also, in order to have the ability to increase the input slowly, when troubleshooting this type of power supply circuit, a variable isolation transformer is required.

NOTE:

The voltage for parts in hot circuit is measured using hot GND as a common terminal.

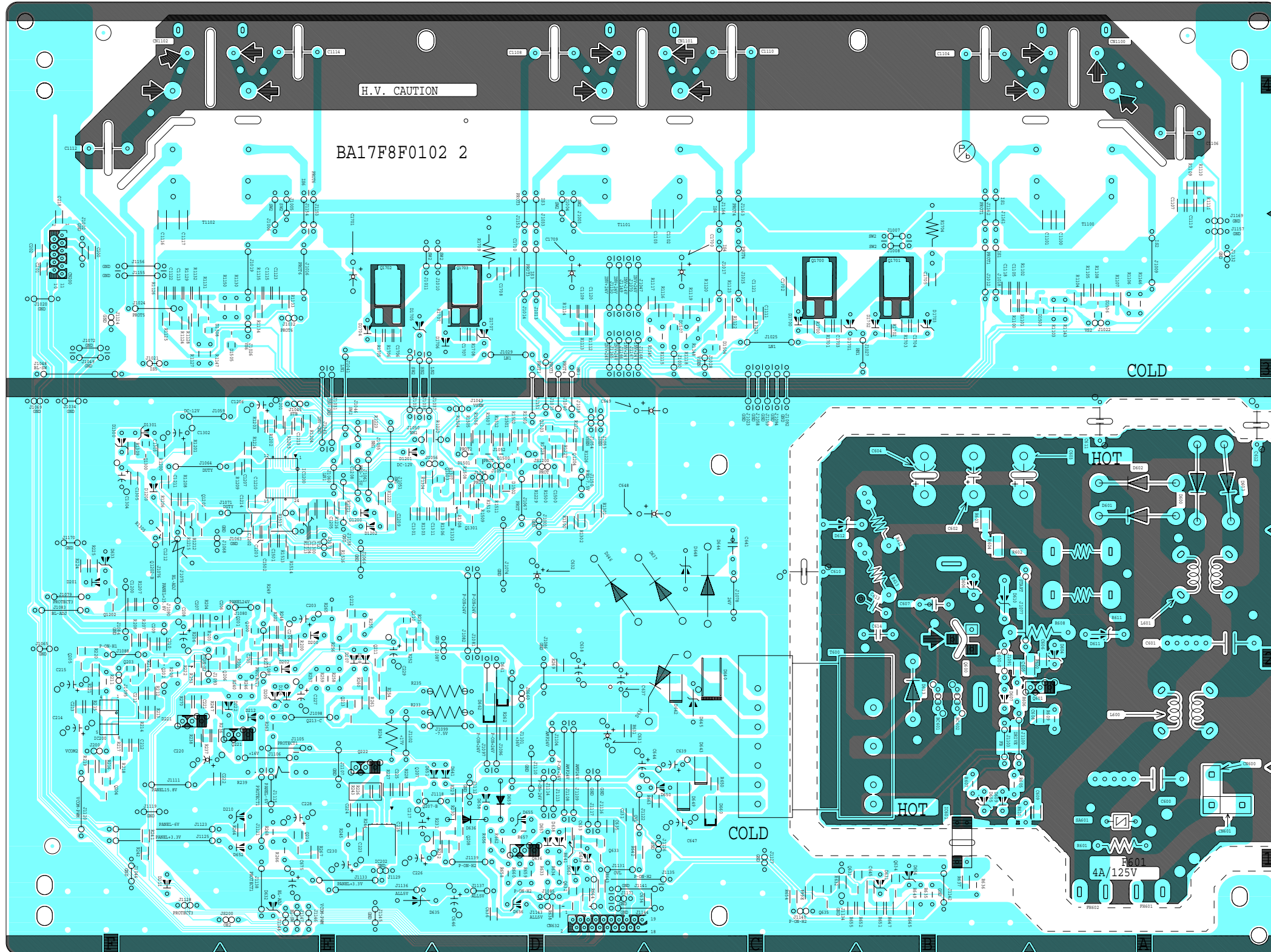

WAVEFORMS

WF1 ~ WF4 = Waveforms to be observed at
Waveform check points.
(Shown in Schematic Diagram.)

Input: Component Color Bar Signal (480i, 480p, 720p or 1080i)
(with 1kHz Audio Signal)

WF1 JK3701(Y-IN)

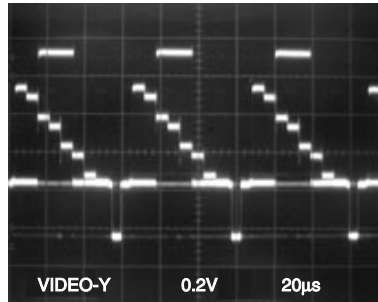

WF2 JK3701(Pb-IN)

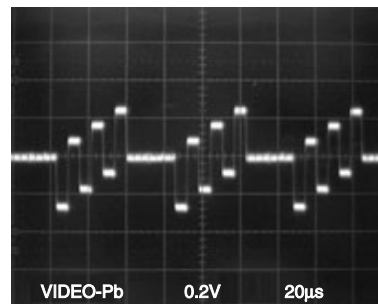

WF3 JK3701(Pr-IN)

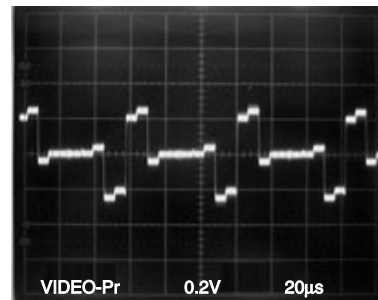

WF4 JK3701(AUDIO(L)-IN)

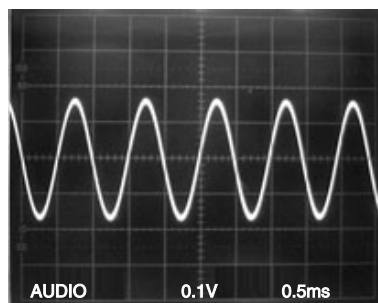

WIRING DIAGRAM

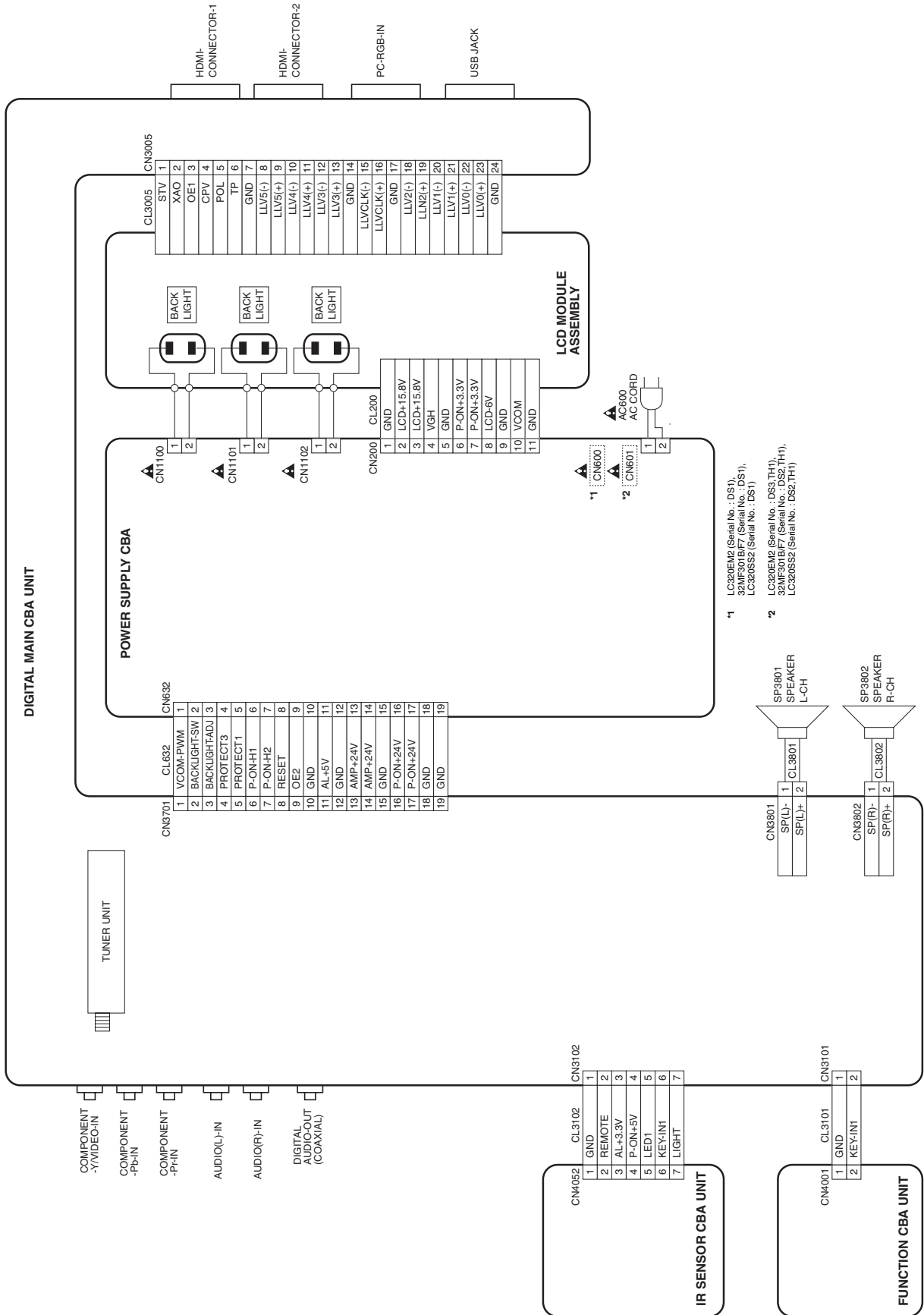

EXPLODED VIEWS

Cabinet [TYPE A]

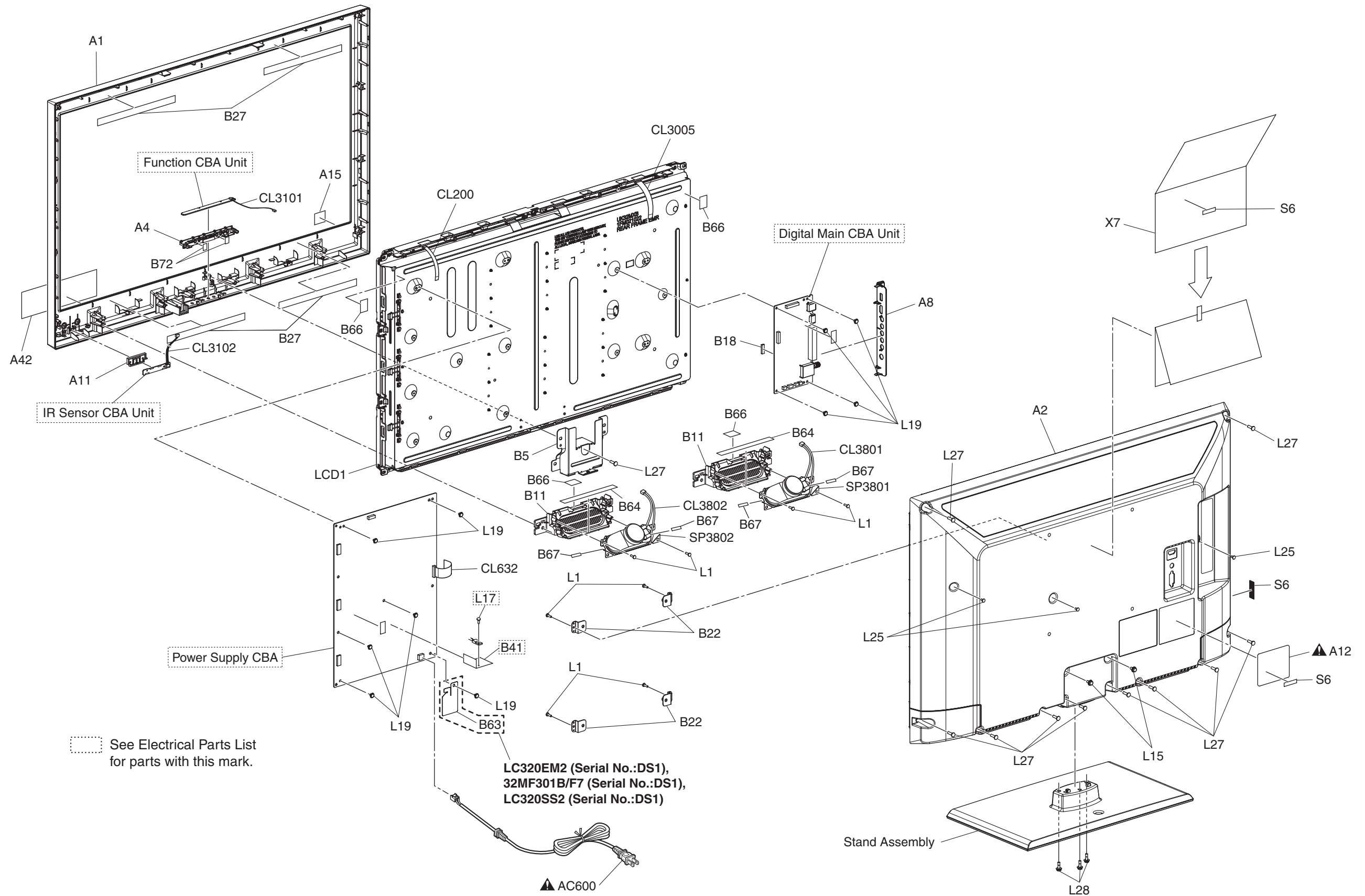

Cabinet [TYPE B]

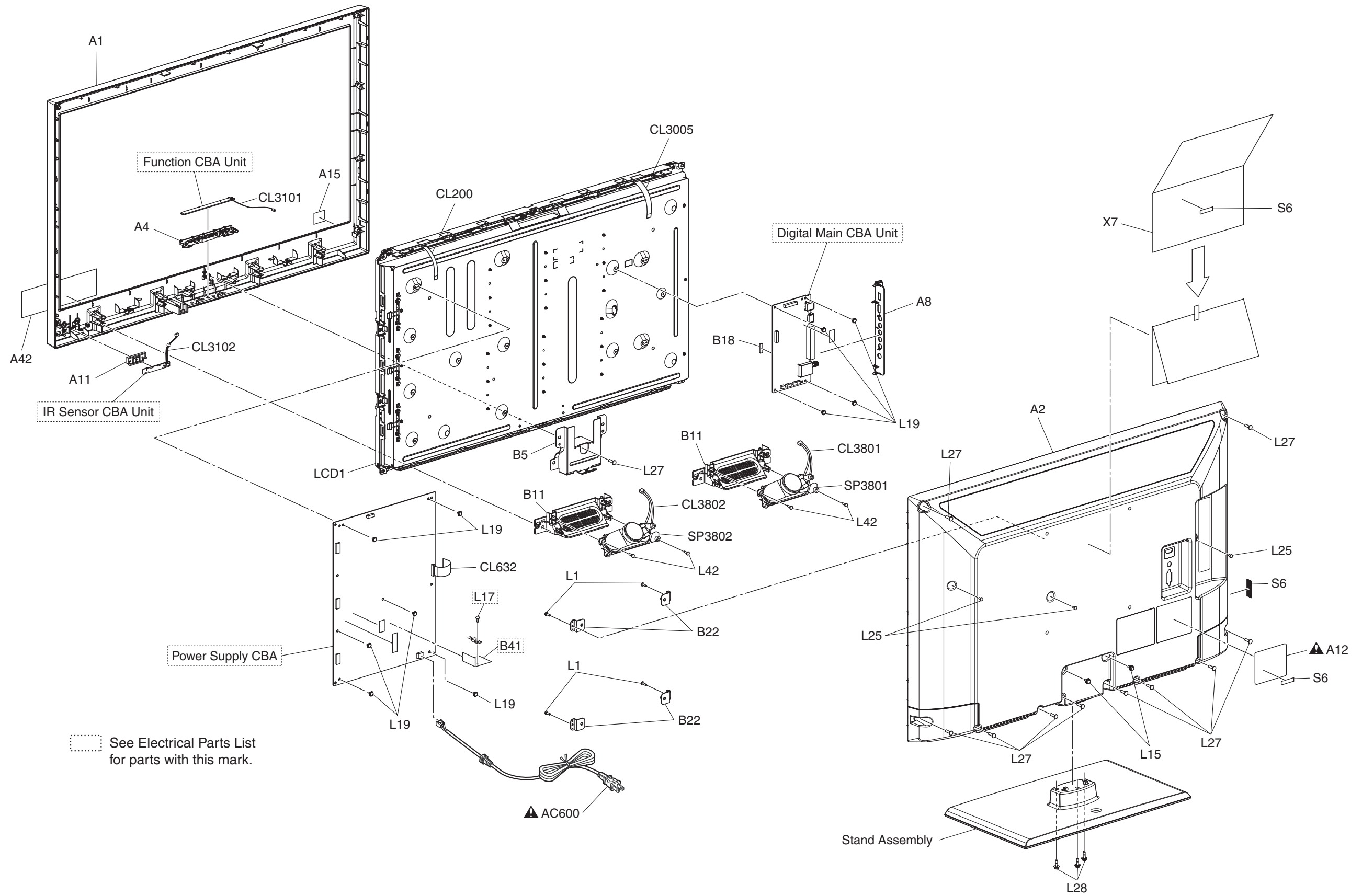

Packing

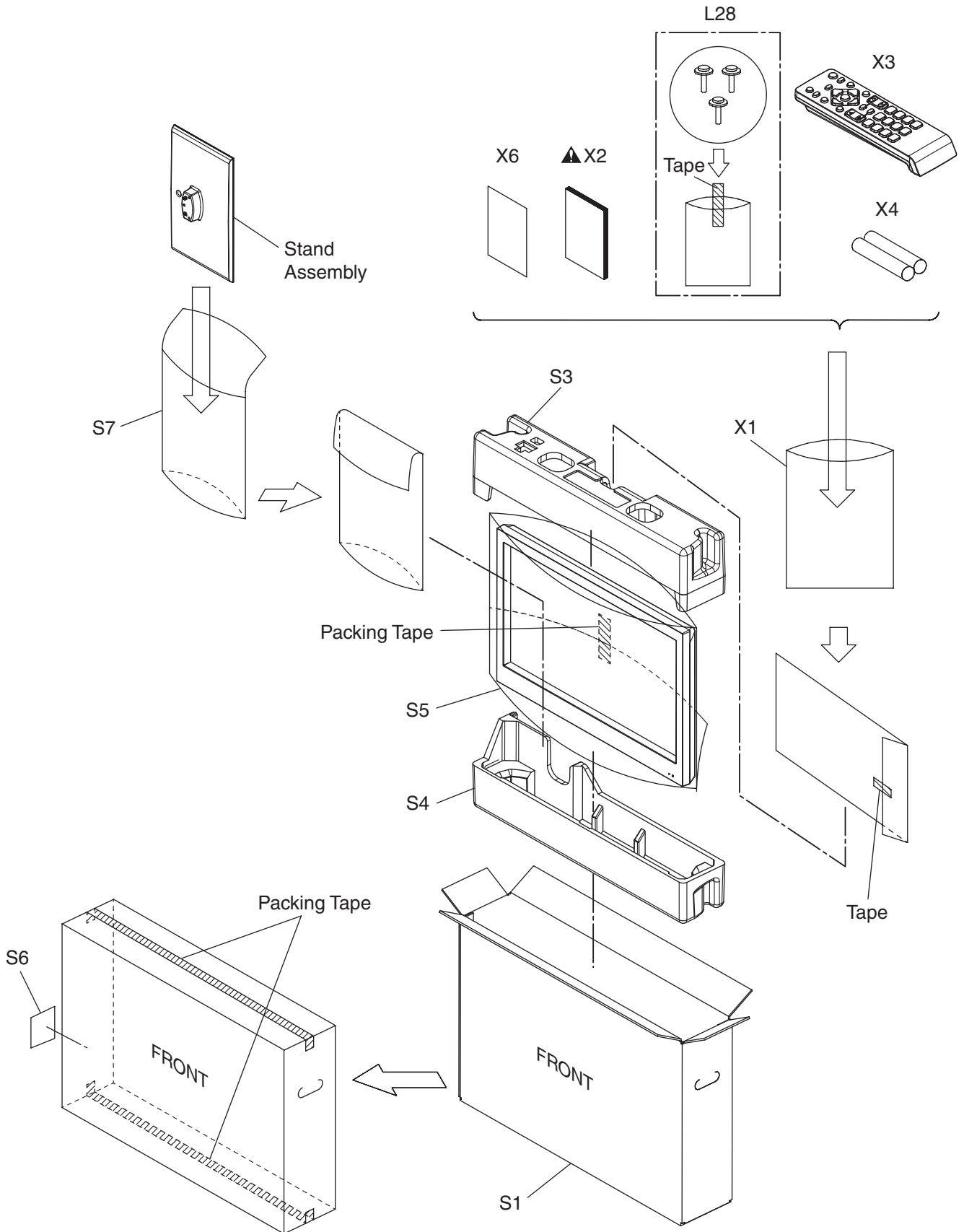

Some Ref. Numbers are not in sequence.

TYPE A

PARTS LIST [32MF301B/F7 (Serial No.: DS1)]

Mechanical Parts

PRODUCT SAFETY NOTE: Products marked with a **▲** have special characteristics important to safety. Before replacing any of these components, read carefully the product safety notice in this service manual. Don't degrade the safety of the product through improper servicing.

NOTE: Parts that are not assigned part numbers (-----) are not available.

Ref. No.	Description	Part No.
	STAND ASSEMBLY A17F1UH	1ESA27585
A1	FRONT CABINET A17F0UH	1EM226003
A2	REAR CABINET A17F1UH	1EM027006
A4	FUNCTION KNOB A17F1UH	1EM226223
A8	JACK HOLDER A17F1UH	1EM225384
A11	SENSOR LENS A17N1UH	1EM329957
A12▲	RATING LABEL A17F0UH	-----
A15	ENERGY STAR LABEL A91F2UH	-----
A42	ENERGY GUIDE LABEL A17F0UH	-----
AC600▲	AC CORD W/O A GND WIRE UL/CSA/1700/NO/BLACK	WAC1720LW005
B5	STAND BRACKET A17F1UH	1EM225385
B11	SPEAKER HOLDER A17F1UH	1EM125714
B18	GASKET A8AF0UH	1EM425861
B22	WALL MOUNT BRACKET A84N0UH	1EM323797
B27	CLOTH(10X180XT0.5) L0336JG	0EM408827
B63	CONNECTOR COVER A17F1UH	1EM331137
B64	CLOTH(10X90XT1.0) A7120UH	1EM424258
B66	CLOTH(15X30XT1.0) B7507UH	0EM402452
B67	CUSHION A17F1UH	1EM435678
B72	CLOTH 15X10XT0.5	1EM420293
CL200	FFC WIRE ASSEMBLY 11PIN 11PIN/110MM	WX1A17F1-101
CL632	FFC WIRE ASSEMBLY 19PIN 19PIN/295MM	WX1A17F1-102
CL3005	FFC WIRE ASSEMBLY 24PIN 24PIN/213MM	WX1A17F1-104
CL3101	WIRE ASSEMBLY 2PIN 2PIN/250MM/BLACK RED	WX1A17F1T205
CL3102	WIRE ASSEMBLY 7PIN 7PIN/600MM/BLACK RED	WX1A17F1T206
CL3801	WIRE ASSEMBLY 2PIN 2PIN/150MM/BLACK RED	WX1A17F1L301
CL3802	WIRE ASSEMBLY 2PIN 2PIN/480MM/BLACK RED	WX1A17F1R302
L1	SCREW P-TIGHT 3X10 BIND HEAD+	GBHP3100
L15	DOUBLE SEMS SCREW M4X10 + BLK	FPH34100
L19	ASSEMBLED SCREW (D9 M3X6) A71F0UH	1EM424392B
L25	S-TIGHT SCREW M3X6 BIND HEAD+BLACK	GBHS3060
L27	SCREW P-TIGHT M4X14 BIND HEAD+BLK	GBHP4140
L28	STAND SCREW KIT A17F1UH	1ESA27587
LCD1	LCD MODULE 31.5INCH 31.5INCH	UK32MXB
SP3801	SPEAKER MAGNETIC S0412F28A	DS08130XQ001
SP3802	SPEAKER MAGNETIC S0412F28A	DS08130XQ001
PACKING		
S1	CARTON A17F0UH	1EM434844
S3	STYROFOAM TOP A17F1UH	1EM027385

Ref. No.	Description	Part No.
S4	STYROFOAM BOTTOM A17F1UH	1EM027386
S5	SET BAG A17F6UH	1EM330877
S6	SERIAL NO. LABEL A01PBUH	-----
S7	STAND BAG A94F0UH	1EM428757
ACCESSORIES		
X1	BAG POLYETHYLENE 235X365XT0.03	0EM408420A
X2▲	OWNERS MANUAL A17F0UH	1EMN27701
X3	REMOTE CONTROL NF805UD	NF805UD
X4	DRY BATTERY R03/2S	XB0M451T0006
X6	QUICK START GUIDE A17F0UH	1EMN27702
X7	REGISTRATION CARD (MAGNAVOX) A17N0UH	1EMN27759

Electrical Parts

PRODUCT SAFETY NOTE: Products marked with a **▲** have special characteristics important to safety. Before replacing any of these components, read carefully the product safety notice in this service manual. Don't degrade the safety of the product through improper servicing.

NOTES:

- Parts that are not assigned part numbers (-----) are not available.
- Tolerance of Capacitors and Resistors are noted with the following symbols.

C.....±0.25% D.....±0.5% F.....±1%
 G.....±2% J.....±5% K.....±10%
 M.....±20% N.....±30% Z.....+80/-20%

DIGITAL ASSEMBLY

Ref. No.	Description	Part No.
	DIGITAL ASSEMBLY Consists of the following	A17F0MMA-004
	DIGITAL MAIN CBA UNIT	A17F0MMA-004-DM
	FUNCTION CBA UNIT	A17F0MMA-004-FN
	IR SENSOR CBA UNIT	A17F0MMA-004-IR

POWER SUPPLY CBA

Ref. No.	Description	Part No.
	POWER SUPPLY CBA Consists of the following:	A17F1MPW-001
CAPACITORS		
C200	CHIP CERAMIC CAP.(1608) F Z 0.1µF/50V	CHD1JZ30F104
C201	CHIP CERAMIC CAP.(1608) F Z 0.1µF/50V	CHD1JZ30F104
C202	CHIP CERAMIC CAP.(1608) F Z 0.1µF/50V	CHD1JZ30F104
C203	ELECTROLYTIC CAP. 2.2µF/50V M	CE1JMASDL2R2
C205	CHIP CERAMIC CAP.(1608) B K 0.1µF/50V	CHD1JK30B104
C208	ELECTROLYTIC CAP. 22µF/50V M	CE1JMASDL220
C211	CHIP CERAMIC CAP.(1608) CH J 1000pF/50V	CHD1JJ3CH102
C212	CHIP CERAMIC CAP.(1608) B K 0.1µF/50V	CHD1JK30B104
C213	CHIP CERAMIC CAP.(1608) B K 1µF/25V	CHD1EK30B105
C214	ELECTROLYTIC CAP. 47µF/25V M	CE1EMASDL470
C216	CHIP CERAMIC CAP.(1608) B K 0.1µF/50V	CHD1JK30B104
C217	ELECTROLYTIC CAP. 10µF/50V M	CE1JMASDL100
C220	ELECTROLYTIC CAP. 470µF/25V M	CE1EMASDL471
C221	CHIP CERAMIC CAP.(1608) B K 0.01µF/50V	CHD1JK30B103
C223	CHIP CERAMIC CAP.(1608) B K 1µF/25V	CHD1EK30B105
C225	CHIP CERAMIC CAP.(1608) B K 0.1µF/50V	CHD1JK30B104
C226	ELECTROLYTIC CAP. 3.3µF/50V M	CE1JMASDL3R3
C227	ELECTROLYTIC CAP. 22µF/50V M	CE1JMASDL220
C228	ELECTROLYTIC CAP. 2.2µF/50V M	CE1JMASDL2R2
C230	ELECTROLYTIC CAP. 100µF/10V M	CE1AMASDL101
C231	CHIP CERAMIC CAP.(1608) F Z 0.1µF/50V	CHD1JZ30F104
C600▲	CAP METALIZED FILM 0.47µF/300V K 3.5MM	CT2F474DC004
C601▲	CAP METALIZED FILM 0.47µF/300V K 3.5MM	CT2F474DC004
C603	CAP ELECTROLYTIC 270µF/200V	CEA271DYG005
C604	CAP ELECTROLYTIC 270µF/200V	CEA271DYG005
C605	CHIP CERAMIC CAP.(1608) B K 0.1µF/50V	CHD1JK30B104
C606	CHIP CERAMIC CAP. B K 1200pF/50V	CHD1JK30B122

Ref. No.	Description	Part No.
C607	CERAMIC CAP. 820pF/2KV	CA3D821PAN04
C608	CHIP CERAMIC CAP. B K 0.068µF/50V	CHD1JK30B683
C609	CHIP CERAMIC CAP. B K 1500pF/50V	CHD1JK30B152
C610▲	SAFTY CAP. 1000pF/250V KX	CA2E102MR101
C611▲	SAFTY CAP. 1000pF/250V KX	CA2E102MR101
C612▲	SAFTY CAP. 1000pF/250V KX	CA2E102MR101
C613	CERAMIC CAP. 2200pF/1KV	CCD3AKA0R222
C631	ELECTROLYTIC CAP. 1000µF/35V M	CE1GMZADL102
C632	ELECTROLYTIC CAP. 1000µF/35V M	CE1GMZADL102
C634	CHIP CERAMIC CAP.(1608) F Z 0.1µF/50V	CHD1JZ30F104
C635	CHIP CERAMIC CAP.(1608) F Z 0.1µF/50V	CHD1JZ30F104
C636	CHIP CERAMIC CAP.(1608) F Z 0.1µF/50V	CHD1JZ30F104
C637	ELECTROLYTIC CAP. 470µF/25V M	CE1EMASDL471
C638	ELECTROLYTIC CAP. 100µF/25V M	CE1EMASDL101
C639	ELECTROLYTIC CAP. 100µF/10V M	CE1AMASDL101
C641	CERAMIC CAP. 2200pF/1KV	CCD3AKA0R222
C644	ELECTROLYTIC CAP. 1µF/50V M	CE1JMASDL1R0
C645	CHIP CERAMIC CAP. B K 2200pF/50V	CHD1JK30B222
C646	ELECTROLYTIC CAP. 100µF/10V M	CE1AMASDL101
C647	ELECTROLYTIC CAP. 100µF/50V M	CE1JMASDL101
C648	ELECTROLYTIC CAP. 2200µF/35V M	CE1GMZADL222
C649	ELECTROLYTIC CAP. 2200µF/35V M	CE1GMZADL222
C1100	CHIP CERAMIC CAP. F Z 2.2µF/50V	CHF1JZ30F225
C1101	CHIP CERAMIC CAP. F Z 2.2µF/50V	CHF1JZ30F225
C1102	CHIP CERAMIC CAP. F Z 2.2µF/50V	CHF1JZ30F225
C1103	CHIP CERAMIC CAP. F Z 2.2µF/50V	CHF1JZ30F225
C1104	CAP CERAMIC HV 10pF/6.3KV/SLJ	CCC1000MR007
C1105	CHIP CERAMIC CAP. CH J 330pF/50V	CHD1JJ3CH331
C1106	CAP CERAMIC HV 10pF/6.3KV/SLJ	CCC1000MR007
C1107	CHIP CERAMIC CAP. CH J 330pF/50V	CHD1JJ3CH331
C1108	CAP CERAMIC HV 10pF/6.3KV/SLJ	CCC1000MR007
C1109	CHIP CERAMIC CAP. CH J 330pF/50V	CHD1JJ3CH331
C1110	CAP CERAMIC HV 10pF/6.3KV/SLJ	CCC1000MR007
C1111	CHIP CERAMIC CAP. CH J 330pF/50V	CHD1JJ3CH331
C1112	CAP CERAMIC HV 10pF/6.3KV/SLJ	CCC1000MR007
C1113	CHIP CERAMIC CAP. CH J 330pF/50V	CHD1JJ3CH331
C1114	CAP CERAMIC HV 10pF/6.3KV/SLJ	CCC1000MR007
C1115	CHIP CERAMIC CAP. CH J 330pF/50V	CHD1JJ3CH331
C1116	CHIP CERAMIC CAP. F Z 2.2µF/50V	CHF1JZ30F225
C1117	CHIP CERAMIC CAP. F Z 2.2µF/50V	CHF1JZ30F225
C1118	CHIP CERAMIC CAP. CH J 330pF/50V	CHD1JJ3CH331
C1119	CHIP CERAMIC CAP. CH J 330pF/50V	CHD1JJ3CH331
C1120	CHIP CERAMIC CAP. CH J 330pF/50V	CHD1JJ3CH331
C1121	CHIP CERAMIC CAP. CH J 330pF/50V	CHD1JJ3CH331
C1122	CHIP CERAMIC CAP. CH J 330pF/50V	CHD1JJ3CH331
C1123	CHIP CERAMIC CAP. CH J 330pF/50V	CHD1JJ3CH331
C1201	CHIP CERAMIC CAP.(1608) B K 0.1µF/50V	CHD1JK30B104
C1202	CHIP CERAMIC CAP.(1608) B K 6800pF/50V	CHD1JK30B682
C1203	CHIP CERAMIC CAP.(1608) B K 6800pF/50V	CHD1JK30B682
C1204	CHIP CERAMIC CAP.(1608) B K 0.1µF/50V	CHD1JK30B104
C1205	CHIP CERAMIC CAP. F Z 2.2µF/50V	CHF1JZ30F225
C1206	ELECTROLYTIC CAP. 10µF/50V M	CE1JMASDL100
C1207	CHIP CERAMIC CAP.(1608) B K 1000pF/50V	CHD1JK30B102
C1208	CAP CHIP 3216 B K 0.47µF/50V	CA1J474TE142
C1209	CAP CHIP 3216 B K 0.47µF/50V	CA1J474TE142
C1210	CHIP CERAMIC CAP.(1608) B K 0.47µF/16V	CHD1CK30B474
C1212	CHIP CERAMIC CAP.(1608) B K 0.47µF/16V	CHD1CK30B474
C1213	CHIP CERAMIC CAP.(1608) B K 0.01µF/50V	CHD1JK30B103
C1300	CHIP CERAMIC CAP.(1608) B K 0.1µF/50V	CHD1JK30B104

Ref. No.	Description	Part No.
C1301	CHIP CERAMIC CAP.(1608) B K 1000pF/50V	CHD1JK30B102
C1302	ELECTROLYTIC CAP. 10μF/50V M	CE1JMASDL100
C1303	CHIP CERAMIC CAP.(1608) B K 0.1μF/50V	CHD1JK30B104
C1304	ELECTROLYTIC CAP. 220μF/35V M	CE1GMASDL221
C1305	CHIP CERAMIC CAP.(1608) B K 0.1μF/50V	CHD1JK30B104
C1311	CHIP CERAMIC CAP.(1608) B K 1000pF/50V	CHD1JK30B102
C1500	CHIP CERAMIC CAP.(1608) B K 0.01μF/50V	CHD1JK30B103
C1501	CHIP CERAMIC CAP.(1608) B K 1000pF/50V	CHD1JK30B102
C1502	CHIP CERAMIC CAP.(1608) B K 3300pF/50V	CHD1JK30B332
C1700	ELECTROLYTIC CAP. 2200μF/35V M	CE1GMZNDL222
C1702	CAP CHIP 3216 B K 1μF/50V	CA1J105TE142
C1703	CHIP CERAMIC CAP.(1608) B K 1000pF/50V	CHD1JK30B102
C1704	CHIP CERAMIC CAP.(1608) B K 1000pF/50V	CHD1JK30B102
C1705	CHIP CERAMIC CAP.(1608) B K 0.022μF/50V	CHD1JK30B223
C1706	CHIP CERAMIC CAP.(1608) B K 1000pF/50V	CHD1JK30B102
C1707	CHIP CERAMIC CAP.(1608) B K 1000pF/50V	CHD1JK30B102
C1708	CHIP CERAMIC CAP.(1608) B K 0.022μF/50V	CHD1JK30B223
C1709	ELECTROLYTIC CAP. 2200μF/35V M	CE1GMZNDL222
C1710	CAP CHIP 3216 B K 1μF/50V	CA1J105TE142
CONNECTORS		
CN200	FFC CONNECTOR IMSA-9615S-11A-PP-A	JC96J11ER007
CN600▲	VH CONNECTOR PRINT OSU B2P3S-VH(LF)(SN)	J3VH030JG002
CN632	FMN CONNECTOR TOP 19P IMSA-9615S-19A-PP-A	JC96J19ER007
CN1100▲	CONNECTOR/JACK 1747386-1	JB17J02AP002
CN1101▲	CONNECTOR/JACK 1747386-1	JB17J02AP002
CN1102▲	CONNECTOR/JACK 1747386-1	JB17J02AP002
DIODES		
D200	SWITCHING DIODE 1SS133(T-77)	QDTZ001SS133
D201	SWITCHING DIODE 1SS133(T-77)	QDTZ001SS133
D202	SWITCHING DIODE 1SS133(T-77)	QDTZ001SS133
D205	DIODE ZENER 24BSC-T26	NDTB024BST26
D206	SWITCHING DIODE 1SS133(T-77)	QDTZ001SS133
D207	SWITCHING DIODE 1SS133(T-77)	QDTZ001SS133
D208	SWITCHING DIODE 1SS133(T-77)	QDTZ001SS133
D210	DIODE ZENER 6V2BSB-T26	NDTB6R2BST26
D211	SWITCHING DIODE 1SS133(T-77)	QDTZ001SS133
D212	SWITCHING DIODE 1SS133(T-77)	QDTZ001SS133
D221	IC SHUNT REGULATOR KIA431-AT/P	NSZBA0TJY036
D222	SWITCHING DIODE 1SS133(T-77)	QDTZ001SS133
D600▲	DIODE GENERAL PURPOSE 1N5406-BU	NDLZ1N5406BU
D601▲	DIODE GENERAL PURPOSE 1N5406-BU	NDLZ1N5406BU
D602▲	DIODE GENERAL PURPOSE 1N5406-BU	NDLZ1N5406BU
D603▲	DIODE GENERAL PURPOSE 1N5406-BU	NDLZ1N5406BU
D604▲	DIODE ZENER 27BSB-T26	NDTB027BST26
D605	DIODE ZENER 4V3BSB-T26	NDTB4R3BST26
D607▲	SWITCHING DIODE 1SS133(T-77)	QDTZ001SS133
D609	SWITCHING DIODE 1SS133(T-77)	QDTZ001SS133
D610▲	DIODE ZENER 1ZB36BB	NDWZ0001ZB36
D611	DIODE ZENER 1ZB220-YBB	NDWZ01ZB220Y
D613	DIODE FAST RECOVERY FR155-B/P	NDWZ0FR155BP
D631	DIODE ZENER 5V6BSB-T26	NDTB5R6BST26
D632	DIODE ZENER 5V6BSB-T26	NDTB5R6BST26
D633	DIODE ZENER 5V6BSB-T26	NDTB5R6BST26
D634	DIODE SCHOTTKY SB3150BH	NDWZ00SB3150
D635	DIODE ZENER 1ZB7.5BB	NDWZ001ZB7R5
D637	DIODE SCHOTTKY SB3150BH	NDWZ00SB3150
D638	DIODE ZENER 10BSB-T26	NDTB010BST26
D639	SWITCHING DIODE 1SS133(T-77)	QDTZ001SS133
D640	DIODE SCHOTTKY SMD SK2B-TR	ND1Z00SK2BTR
D641	SWITCHING DIODE 1SS133(T-77)	QDTZ001SS133
D642	DIODE SK16-T/R	ND1Z0000SK16

Ref. No.	Description	Part No.
D643	DIODE SK16-T/R	ND1Z0000SK16
D644	DIODE SCHOTTKY SB3150BH	NDWZ00SB3150
D645	DIODE ZENER 1ZB22BB	NDWZ0001ZB22
D646	DIODE SCHOTTKY SB3150BH	NDWZ00SB3150
D648	DIODE ZENER 1ZB30BB	NDWZ0001ZB30
D649	DIODE SK16-T/R	ND1Z0000SK16
D650	DIODE ZENER 5V6BSB-T26	NDTB5R6BST26
D651	SWITCHING DIODE 1SS133(T-77)	QDTZ001SS133
D652	SWITCHING DIODE 1SS133(T-77)	QDTZ001SS133
D654	DIODE ZENER 5V6BSB-T26	NDTB5R6BST26
D655	DIODE ZENER 3V3BSB-T26	NDTB3R3BST26
D656	DIODE ZENER 5V6BSB-T26	NDTB5R6BST26
D657	SWITCHING DIODE 1SS133(T-77)	QDTZ001SS133
D658	SWITCHING DIODE 1SS133(T-77)	QDTZ001SS133
D660	DIODE FAST RECOVERY RS1GJT B	ND1Z0RS1GJT B
D663	SWITCHING DIODE 1SS133(T-77)	QDTZ001SS133
D1200	SWITCHING DIODE 1SS133(T-77)	QDTZ001SS133
D1201	SWITCHING DIODE 1SS133(T-77)	QDTZ001SS133
D1202	SWITCHING DIODE 1SS133(T-77)	QDTZ001SS133
D1203	SWITCHING DIODE 1SS133(T-77)	QDTZ001SS133
D1300	DIODE ZENER 5V6BSB-T26	NDTB5R6BST26
D1301	DIODE ZENER 5V6BSB-T26	NDTB5R6BST26
D1500	SWITCHING DIODE DAN202U T106	QD1Z0DAN202U
D1501	SWITCHING DIODE DAN202U T106	QD1Z0DAN202U
D1502	SWITCHING DIODE DAN202U T106	QD1Z0DAN202U
D1503	SWITCHING DIODE DAN202U T106	QD1Z0DAN202U
D1504	SWITCHING DIODE DAN202U T106	QD1Z0DAN202U
D1505	SWITCHING DIODE DAN202U T106	QD1Z0DAN202U
D1506	SWITCHING DIODE DAN202U T106	QD1Z0DAN202U
D1507	SWITCHING DIODE DAN202U T106	QD1Z0DAN202U
D1508	SWITCHING DIODE DAN202U T106	QD1Z0DAN202U
D1700	SWITCHING DIODE 1SS133(T-77)	QDTZ001SS133
D1701	DIODE ZENER 15BSB-T26	NDTB015BST26
D1702	SWITCHING DIODE 1SS133(T-77)	QDTZ001SS133
D1703	DIODE ZENER 15BSB-T26	NDTB015BST26
D1704	SWITCHING DIODE 1SS133(T-77)	QDTZ001SS133
D1705	DIODE ZENER 15BSB-T26	NDTB015BST26
D1706	SWITCHING DIODE 1SS133(T-77)	QDTZ001SS133
D1707	DIODE ZENER 15BSB-T26	NDTB015BST26
ICS		
IC200	IC TL3472CDR	NSZBA0TTY115
IC202	IC(REGULATOR) PQ200WNA1ZPH	QSZBA0TSH072
IC601▲	IC PHOTOCOUPLER TLP781F(D4-FUNBL F)	QPFL781FBLLF
IC1200	IC INVERTER CONTROL BD9244AFV/SSOP/24PIN	QSCA0T0RM222
COILS		
L600▲	COIL LINE FILTER ST0807ET28-009 10MH	LLEG0Z0Y2029
L601▲	COIL LINE FILTER ST0807ET28-009 10MH	LLEG0Z0Y2029
TRANSISTORS		
Q200	PNP TRANSISTOR SMD 2SA1576UBTLQ	QQ1Q2SA1576U
Q201	CHIP TRANSISTOR KTC3875S-Y-RTK/P	NQ1YKTC3875S
Q202	CHIP TRANSISTOR KTC3875S-Y-RTK/P	NQ1YKTC3875S
Q203	PNP TRANSISTOR SMD 2SA1576UBTLQ	QQ1Q2SA1576U
Q204	CHIP TRANSISTOR KTC3875S-Y-RTK/P	NQ1YKTC3875S
Q206	CHIP TRANSISTOR KTC3875S-Y-RTK/P	NQ1YKTC3875S
Q207	PNP TRANSISTOR SMD 2SA1576UBTLQ	QQ1Q2SA1576U
Q208	CHIP TRANSISTOR KTC3875S-Y-RTK/P	NQ1YKTC3875S
Q210	PNP TRANSISTOR SMD 2SA1576UBTLQ	QQ1Q2SA1576U
Q211	CHIP TRANSISTOR KTC3875S-Y-RTK/P	NQ1YKTC3875S
Q212	CHIP TRANSISTOR KTC3875S-Y-RTK/P	NQ1YKTC3875S
Q213	CHIP TRANSISTOR KTC3875S-Y-RTK/P	NQ1YKTC3875S
Q214	CHIP TRANSISTOR KTC3875S-Y-RTK/P	NQ1YKTC3875S
Q221	TRANSISTOR 2SC2120-Y(T E F T)	QQSY2SC2120F

Ref. No.	Description	Part No.
Q222	TRANSISTOR 2SA950-O (TE2 F T)	QQS002SA950F
Q600▲	FET MOS TK10A50D	QFWSZTK10A50D
Q601▲	TRANSISTOR 2SC2120-Y(TE2 F T)	QQSY2SC2120F
Q631	CHIP TRANSISTOR KTC3875S-Y-RTK/P	NQ1YKTC3875S
Q632	CHIP TRANSISTOR KTC3875S-Y-RTK/P	NQ1YKTC3875S
Q633	CHIP TRANSISTOR KTC3875S-Y-RTK/P	NQ1YKTC3875S
Q634	CHIP TRANSISTOR KTC3875S-Y-RTK/P	NQ1YKTC3875S
Q635	CHIP TRANSISTOR KTC3875S-Y-RTK/P	NQ1YKTC3875S
Q636	TRANSISTOR KTC3199-GR-AT/P	NQS4KTC3199P
Q1201	CHIP TRANSISTOR KTC3875S-Y-RTK/P	NQ1YKTC3875S
Q1202	CHIP TRANSISTOR KTC3875S-Y-RTK/P	NQ1YKTC3875S
Q1300	PNP TRANSISTOR SMD 2SA1576UBTLQ	QQ1Q2SA1576U
Q1301	CHIP TRANSISTOR KTC3875S-Y-RTK/P	NQ1YKTC3875S
Q1303	PNP TRANSISTOR SMD 2SA1576UBTLQ	QQ1Q2SA1576U
Q1700▲	FET MOS SMD TK50P04M1(T6RSS-Q)	QF1ZK50P04M1
Q1701▲	FET MOS SMD TK50P04M1(T6RSS-Q)	QF1ZK50P04M1
Q1702▲	FET MOS SMD TK50P04M1(T6RSS-Q)	QF1ZK50P04M1
Q1703▲	FET MOS SMD TK50P04M1(T6RSS-Q)	QF1ZK50P04M1
RESISTORS		
R200	RES CHIP 1608 1/10W J 100k Ω	RRXA104HH013
R201	RES CHIP 1608 1/10W J 1.0k Ω	RRXA102HH013
R203	RES CARBON FILM T 1/4W J 560 Ω	RCX4561T1001
R205	RES CHIP 1608 1/10W J 1.0k Ω	RRXA102HH013
R206	RES CHIP 1608 1/10W J 100k Ω	RRXA104HH013
R207	RES CHIP 1608 1/10W J 1.0 Ω	RRXA1R0HH013
R208	RES CHIP 1608 1/10W 0 Ω	RRXA000HH014
R209	RES CARBON FILM T 1/4W J 10 Ω	RCX4100T1001
R210	RES CHIP 1608 1/10W 0 Ω	RRXA000HH014
R211	RES CARBON FILM T 1/4W J 10 Ω	RCX4100T1001
R212	RES CHIP 1608 1/10W J 100k Ω	RRXA104HH013
R213	RES CHIP 1608 1/10W 0 Ω	RRXA000HH014
R215	RES CHIP 1608 1/10W J 12k Ω	RRXA123HH013
R216	RES CHIP 1608 1/10W J 1.2k Ω	RRXA122HH013
R217	RES CHIP 1608 1/10W J 10k Ω	RRXA103HH013
R218	RES CHIP 1608 1/10W J 15k Ω	RRXA153HH013
R219	RES CHIP 1608 1/10W J 1.0k Ω	RRXA102HH013
R222	RES CHIP 1608 1/10W J 10k Ω	RRXA103HH013
R224	RES CHIP 1608 1/10W J 47k Ω	RRXA473HH013
R225	RES CHIP 1608 1/10W J 10k Ω	RRXA103HH013
R226	RES CHIP 1608 1/10W F 330 Ω	RTW3300HH008
R227	RES CHIP 1608 1/10W J 4.7k Ω	RRXA473HH013
R228	RES CHIP 1608 1/10W J 4.7k Ω	RRXA472HH013
R229	RES CHIP 1608 1/10W J 22k Ω	RRXA223HH013
R230	RES CHIP 1608 1/10W J 10k Ω	RRXA103HH013
R231	RES CHIP 1608 1/10W J 47k Ω	RRXA473HH013
R232	RES CHIP 1608 1/10W J 10k Ω	RRXA103HH013
R233	WIRE COPPER 6111-06003-0120	XZ40C0SHG002
R234	RES. CARBON FILM J 1/2W J 2.2 Ω	RCX22R2T1003
R235	WIRE COPPER 6111-06003-0120	XZ40C0SHG002
R236	RES CHIP 1608 1/10W F 11.0k Ω	RTW1102HH008
R237	RES CHIP 1608 1/10W F 750 Ω	RTW7500HH008
R238	RES CHIP 1608 1/10W F 2.20k Ω	RTW2201HH008
R239	METAL OXIDE FILM RES. 1W J 8.2 Ω	RN018R2ZU001
R240	RES CARBON FILM T 1/4W J 3.9k Ω	RCX4392T1001
R241	RES CHIP 1608 1/10W J 6.8k Ω	RRXA682HH013
R242	RES CHIP 1608 1/10W J 2.7k Ω	RRXA272HH013
R243	RES CHIP 1608 1/10W F 240 Ω	RTW2400HH008
R244	RES CHIP 1608 1/10W F 2.20k Ω	RTW2201HH008
R246	RES CARBON FILM T 1/4W J 3.9k Ω	RCX4392T1001
R247	RES CHIP 1608 1/10W J 100k Ω	RRXA104HH013
R248	RES CHIP 1608 1/10W J 56k Ω	RRXA563HH013
R249	RES CHIP 1608 1/10W J 6.8k Ω	RRXA682HH013

Ref. No.	Description	Part No.
R251	RES CHIP 1608 1/10W J 22k Ω	RRXA223HH013
R252	RES CHIP 1608 1/10W J 39k Ω	RRXA393HH013
R253	RES CHIP 1608 1/10W J 22k Ω	RRXA223HH013
R254	RES CHIP 1608 1/10W J 22k Ω	RRXA223HH013
R255	RES CARBON FILM T 1/4W J 390 Ω	RCX4391T1001
R256	WIRE COPPER 6111-06003-0120	XZ40C0SHG002
R257	RES CARBON FILM T 1/4W J 8.2k Ω	RCX4822T1001
R258	RES CARBON FILM T 1/4W J 2.7k Ω	RCX4272T1001
R260	RES CHIP 1608 1/10W J 47k Ω	RRXA473HH013
R261	RES CHIP 1608 1/10W J 22k Ω	RRXA223HH013
R262	RES CHIP 1608 1/10W J 12k Ω	RRXA123HH013
R263	RES CARBON FILM T 1/4W J 470 Ω	RCX4471T1001
R264	RES CHIP 1608 1/10W J 15k Ω	RRXA153HH013
R265	RES CARBON FILM T 1/4W J 8.2k Ω	RCX4822T1001
R266	RES CARBON FILM T 1/4W J 47k Ω	RCX4473T1001
R267	RES CHIP 1608 1/10W J 47k Ω	RRXA473HH013
R268	RES CARBON FILM T 1/4W J 47k Ω	RCX4473T1001
R269	RES CHIP 1608 1/10W J 12k Ω	RRXA123HH013
R270	RES CHIP 1608 1/10W J 1.5k Ω	RRXA152HH013
R600	RES CHIP 3216 1/4W J 220k Ω	RRX4224HH034
R601▲	RES. CARBON FILM J 1/2W J 1.2M Ω	RCX2125T1003
R602▲	CEMENT RESISTOR 5W J 2.2 Ω H 10MM	RW052R2PAK10
R603	RES CHIP 3216 1/4W J 220k Ω	RRX4224HH034
R604	RES CHIP 3216 1/4W J 220k Ω	RRX4224HH034
R605	RES CARBON FILM T 1/4W J 220 Ω	RCX4221T1001
R606	RES CARBON FILM T 1/4W J 180 Ω	RCX4181T1001
R607	RES CARBON FILM T 1/4W J 1.2k Ω	RCX4122T1001
R608▲	METAL OXIDE FILM RES. 2W J 0.18 Ω	RN02R18ZU001
R609	RES CARBON FILM T 1/4W J 3.9k Ω	RCX4392T1001
R610	RES CARBON FILM T 1/4W J 270 Ω	RCX4271T1001
R611▲	CEMENT RESISTOR 5W J 2.2 Ω H 10MM	RW052R2PAK10
R612	METAL OXIDE FILM RES. 1W J 68k Ω	RN01683ZU001
R613	METAL OXIDE FILM RES. 1W J 68k Ω	RN01683ZU001
R631	RES CHIP 1608 1/10W J 15k Ω	RRXA153HH013
R632	RES CHIP 1608 1/10W J 47k Ω	RRXA473HH013
R633	WIRE COPPER 6111-06003-0120	XZ40C0SHG002
R634	WIRE COPPER 6111-06003-0120	XZ40C0SHG002
R635	RES CARBON FILM T 1/4W J 120 Ω	RCX4121T1001
R636	RES CARBON FILM T 1/4W J 120 Ω	RCX4121T1001
R637	RES CHIP 1608 1/10W J 10k Ω	RRXA103HH013
R638	RES CHIP 1608 1/10W J 22k Ω	RRXA223HH013
R641	RES CHIP 1608 1/10W J 22k Ω	RRXA223HH013
R642	RES CHIP 1608 1/10W F 43.0k Ω	RTW4302HH008
R643	RES CHIP 1608 1/10W F 47.0k Ω	RTW4702HH008
R644	RES CHIP 1608 1/10W J 18k Ω	RRXA183HH013
R645	RES CHIP 1608 1/10W F 27.0k Ω	RTW2702HH008
R647	RES CHIP 1608 1/10W F 27.0k Ω	RTW2702HH008
R649	RES CARBON FILM T 1/4W J 3.9k Ω	RCX4392T1001
R650	RES CHIP 1608 1/10W J 1.0 Ω	RRXA1R0HH013
R651	RES CHIP 1608 1/10W F 820 Ω	RTW8200HH008
R652	RES CHIP 1608 1/10W F 18.0k Ω	RTW1802HH008
R654	RES CHIP 1608 1/10W J 10k Ω	RRXA103HH013
R655	RES CHIP 1608 1/10W J 47k Ω	RRXA473HH013
R656	RES CARBON FILM T 1/4W J 220 Ω	RCX4221T1001
R657	RES CARBON FILM T 1/4W J 15 Ω	RCX4150T1001
R658	RES CARBON FILM T 1/4W J 220 Ω	RCX4221T1001
R659	RES CARBON FILM T 1/4W J 220 Ω	RCX4221T1001
R660	WIRE COPPER 6111-06003-0120	XZ40C0SHG002
R662	RES CARBON FILM T 1/4W J 220 Ω	RCX4221T1001
R663	RES CHIP 1608 1/10W J 39k Ω	RRXA393HH013
R664	RES CHIP 1608 1/10W J 10k Ω	RRXA103HH013
R1100	RES CHIP 1608 1/10W F 39.0k Ω	RTW3902HH008
R1101	RES CHIP 1608 1/10W 0 Ω	RRXA000HH014

Ref. No.	Description	Part No.
R1102	RES CHIP 1608 1/10W F 2.20k Ω	RTW2201HH008
R1103	RES CARBON FILM T 1/4W G 470 Ω	RCX4471T1002
R1104	RES CHIP 1608 1/10W F 100 Ω	RTW1000HH008
R1105	RES CHIP 1608 1/10W F 13.0 Ω	RTW13R0HH008
R1106	RES CARBON FILM T 1/4W G 470 Ω	RCX4471T1002
R1107	RES CHIP 1608 1/10W F 100 Ω	RTW1000HH008
R1108	RES CHIP 1608 1/10W F 13.0 Ω	RTW13R0HH008
R1109	RES CHIP 1608 1/10W F 39.0k Ω	RTW3902HH008
R1110	RES CHIP 1608 1/10W 0 Ω	RRXA000HH014
R1111	RES CHIP 1608 1/10W F 2.20k Ω	RTW2201HH008
R1112	RES CHIP 1608 1/10W F 39.0k Ω	RTW3902HH008
R1113	RES CHIP 1608 1/10W 0 Ω	RRXA000HH014
R1114	RES CHIP 1608 1/10W F 2.20k Ω	RTW2201HH008
R1115	RES CARBON FILM T 1/4W G 470 Ω	RCX4471T1002
R1116	RES CHIP 1608 1/10W F 100 Ω	RTW1000HH008
R1117	RES CHIP 1608 1/10W F 13.0 Ω	RTW13R0HH008
R1118	RES CARBON FILM T 1/4W G 470 Ω	RCX4471T1002
R1119	RES CHIP 1608 1/10W F 100 Ω	RTW1000HH008
R1120	RES CHIP 1608 1/10W F 13.0 Ω	RTW13R0HH008
R1121	RES CHIP 1608 1/10W F 39.0k Ω	RTW3902HH008
R1122	RES CHIP 1608 1/10W 0 Ω	RRXA000HH014
R1123	RES CHIP 1608 1/10W F 2.20k Ω	RTW2201HH008
R1124	RES CHIP 1608 1/10W F 39.0k Ω	RTW3902HH008
R1125	RES CHIP 1608 1/10W 0 Ω	RRXA000HH014
R1126	RES CHIP 1608 1/10W F 2.20k Ω	RTW2201HH008
R1127	RES CARBON FILM T 1/4W G 470 Ω	RCX4471T1002
R1128	RES CHIP 1608 1/10W F 100 Ω	RTW1000HH008
R1129	RES CHIP 1608 1/10W F 13.0 Ω	RTW13R0HH008
R1130	RES CARBON FILM T 1/4W G 470 Ω	RCX4471T1002
R1131	RES CHIP 1608 1/10W F 100 Ω	RTW1000HH008
R1132	RES CHIP 1608 1/10W F 13.0 Ω	RTW13R0HH008
R1133	RES CHIP 1608 1/10W F 39.0k Ω	RTW3902HH008
R1134	RES CHIP 1608 1/10W 0 Ω	RRXA000HH014
R1135	RES CHIP 1608 1/10W F 2.20k Ω	RTW2201HH008
R1200	RES CHIP 1608 1/10W J 68k Ω	RRXA683HH013
R1201	RES CHIP 1608 1/10W J 68k Ω	RRXA683HH013
R1202	RES CHIP 1608 1/10W F 130k Ω	RTW1303HH008
R1203	RES CHIP 1608 1/10W F 8.20k Ω	RTW8201HH008
R1204	RES CHIP 1608 1/10W F 75.0k Ω	RTW7502HH008
R1205	RES CHIP 1608 1/10W F 560k Ω	RTW5603HH008
R1206	RES CHIP 1608 1/10W J 10k Ω	RRXA103HH013
R1207	RES CHIP 1608 1/10W J 33k Ω	RRXA333HH013
R1208	RES CHIP 1608 1/10W J 22k Ω	RRXA223HH013
R1209	RES CHIP 1608 1/10W J 4.7k Ω	RRXA472HH013
R1212	RES CHIP 1608 1/10W J 10k Ω	RRXA103HH013
R1213	RES CHIP 1608 1/10W J 4.7k Ω	RRXA472HH013
R1214	RES CHIP 1608 1/10W 0 Ω	RRXA000HH014
R1215	RES CHIP 1608 1/10W J 10k Ω	RRXA103HH013
R1216	RES CHIP 1608 1/10W J 100 Ω	RRXA101HH013
R1221	RES CHIP 1608 1/10W J 1.0 Ω	RRXA1R0HH013
R1222	RES CHIP 1608 1/10W J 10 Ω	RRXA100HH013
R1223	RES CHIP 1608 1/10W J 10 Ω	RRXA100HH013
R1229	RES CHIP 1608 1/10W 0 Ω	RRXA000HH014
R1300	RES CHIP 1608 1/10W F 10.0k Ω	RTW1002HH008
R1301	RES CHIP 1608 1/10W F 47.0k Ω	RTW4702HH008
R1302	RES CHIP 1608 1/10W F 51.0k Ω	RTW5102HH008
R1303	RES CHIP 1608 1/10W J 4.7k Ω	RRXA472HH013
R1304	RES CHIP 1608 1/10W J 4.7k Ω	RRXA472HH013
R1305	METAL OXIDE RES. 2W J 510 Ω	RN02511ZU001
R1306	RES CHIP 1608 1/10W J 10k Ω	RRXA103HH013
R1307	RES CHIP 1608 1/10W J 1.0k Ω	RRXA102HH013
R1308	RES CHIP 1608 1/10W J 4.7k Ω	RRXA472HH013
R1309	RES CHIP 1608 1/10W J 10k Ω	RRXA103HH013

Ref. No.	Description	Part No.
R1310	RES CHIP 1608 1/10W J 22k Ω	RRXA223HH013
R1500	RES CHIP 1608 1/10W F 1.00M Ω	RTW1004HH008
R1501	RES CHIP 1608 1/10W F 100k Ω	RTW1003HH008
R1502	RES CHIP 1608 1/10W F 100k Ω	RTW1003HH008
R1503	RES CHIP 1608 1/10W F 100k Ω	RTW1003HH008
R1504	RES CHIP 1608 1/10W F 100k Ω	RTW1003HH008
R1505	RES CHIP 1608 1/10W F 100k Ω	RTW1003HH008
R1506	RES CHIP 1608 1/10W F 100k Ω	RTW1003HH008
R1507	RES CHIP 1608 1/10W F 100k Ω	RTW1003HH008
R1508	RES CHIP 1608 1/10W F 100k Ω	RTW1003HH008
R1509	RES CHIP 1608 1/10W F 100k Ω	RTW1003HH008
R1510	RES CHIP 1608 1/10W F 100k Ω	RTW1003HH008
R1511	RES CHIP 1608 1/10W F 100k Ω	RTW1003HH008
R1512	RES CHIP 1608 1/10W F 100k Ω	RTW1003HH008
R1513	RES CHIP 1608 1/10W F 1.00M Ω	RTW1004HH008
R1514	RES CHIP 1608 1/10W F 39.0k Ω	RTW3902HH008
R1515	RES CHIP 1608 1/10W F 27.0k Ω	RTW2702HH008
R1516	RES CHIP 1608 1/10W F 6.80k Ω	RTW6801HH008
R1700	RES CHIP 1608 1/10W J 100 Ω	RRXA101HH013
R1701	RES CHIP 1608 1/10W J 10k Ω	RRXA103HH013
R1702	RES CHIP 1608 1/10W J 100 Ω	RRXA101HH013
R1703	RES CHIP 1608 1/10W J 10k Ω	RRXA103HH013
R1704	METAL OXIDE FILM RES. 1W J 4.7 Ω	RN014R7ZU001
R1705	RES CHIP 1608 1/10W J 100 Ω	RRXA101HH013
R1706	RES CHIP 1608 1/10W J 10k Ω	RRXA103HH013
R1707	RES CHIP 1608 1/10W J 100 Ω	RRXA101HH013
R1708	RES CHIP 1608 1/10W J 10k Ω	RRXA103HH013
R1709	METAL OXIDE FILM RES. 1W J 4.7 Ω	RN014R7ZU001
MISCELLANEOUS		
B41	HEAT SINK PNB ASSEMBLY A94FOUH	1EM428123
BC601	BEADS INDUCTOR FBR07HA121SB-00	LLBF00STU030
BC602	BEADS INDUCTOR FBR07HA121SB-00	LLBF00STU030
F601▲	FUSE STC4A125V U/CT	PAGE20CW3402
FH601	FUSE HOLDER MSF-015 LF (B110)	XH01Z00LY002
FH602	FUSE HOLDER MSF-015 LF (B110)	XH01Z00LY002
JS200	WIRE COPPER 6111-06003-0120	XZ40C0SHG002
JS660	WIRE COPPER 6111-06003-0120	XZ40C0SHG002
JS1200	WIRE COPPER 6111-06003-0120	XZ40C0SHG002
L17	SCREW B-TIGHT D3X8 BIND HEAD+	GBJB3080
SA601▲	SURGE ABSORBER 470V+10PER	NVQZ10D471KB
T600▲	TRANS POWER 11714	LTT3PCOKT069
When you replace one of the below Trans Inverters on this CBA, please replace with the one that has same parts number. Do not mix different parts number's Trans Inverter.		
T1100▲	TRANS INV HVT-325	LTZ3PZ0XB018
T1101▲	TRANS INV HVT-325	LTZ3PZ0XB018
T1102▲	TRANS INV HVT-325	LTZ3PZ0XB018
or		
T1100▲	TRANS INV TZ.7617A.101	LTZ3PZDAR014
T1101▲	TRANS INV TZ.7617A.101	LTZ3PZDAR014
T1102▲	TRANS INV TZ.7617A.101	LTZ3PZDAR014

TYPE A

PARTS LIST [LC320EM2 (Serial No.: DS1)]

Mechanical Parts

PRODUCT SAFETY NOTE: Products marked with a **▲** have special characteristics important to safety. Before replacing any of these components, read carefully the product safety notice in this service manual. Don't degrade the safety of the product through improper servicing.

NOTE: Parts that are not assigned part numbers (-----) are not available.

Different parts from the original model 32MF301B/F7 (Serial No. : DS1)

Ref. No.	Description	Part No.
A1	FRONT CABINET A17F1UH	1EM027005
A12▲	RATING LABEL A17F1UH	-----
A42	ENERGY GUIDE LABEL A17F1UH	-----
S1	CARTON A17F1UH	1EM330221
X2▲	OWNERS MANUAL A17F1UH	1EMN27479
X3	REMOTE CONTROL NH001UD	NH001UD
X6	QUICK START GUIDE A17F1UH	1EMN27480
X7	REGISTRATION CARD (EMERSON) A17N1UH	1EMN27763

Electrical Parts

PRODUCT SAFETY NOTE: Products marked with a **▲** have special characteristics important to safety. Before replacing any of these components, read carefully the product safety notice in this service manual. Don't degrade the safety of the product through improper servicing.

NOTES:

1. Parts that are not assigned part numbers (-----) are not available.
2. Tolerance of Capacitors and Resistors are noted with the following symbols.

C.....±0.25% D.....±0.5% F.....±1%
 G.....±2% J.....±5% K.....±10%
 M.....±20% N.....±30% Z.....+80/-20%

**Different parts from the original model
 32MF301B/F7 (Serial No. : DS1)**

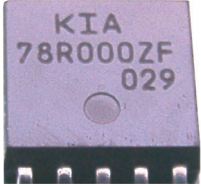
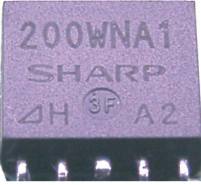
Ref. No.	Description	Part No.
	DIGITAL ASSEMBLY Consists of the following	A17F1MMA-006
	DIGITAL MAIN CBA UNIT	A17F1MMA-006-DM
	FUNCTION CBA UNIT	A17F1MMA-006-FN
	IR SENSOR CBA UNIT	A17F1MMA-006-IR
	POWER SUPPLY CBA	-----
You cannot mix components under Type 1 with the ones under Type 2.		
Type 1: ("78R000ZF" is engraved on Type 1 IC REGULATOR.)		
IC202	IC REGULATOR KIA78R000ZF-RTF/P	NSCA0T0JY016
R226	RES CHIP 1608 1/10W F 1.4k Ω	RTW1401HH008
R244	RES CHIP 1608 1/10W F 1k Ω	RTW1001HH008
 <p>← Make sure to use this IC202 with R226 (1.4k Ω) and R244 (1k Ω).</p>		
or		
Type 2: ("200WNA1" is engraved on Type 2 IC REGULATOR.)		
IC202	IC(REGULATOR) PQ200WNA1ZPH	QSZBA0TSH072
R226	RES CHIP 1608 1/10W F 330 Ω	RTW3300HH008
R244	RES CHIP 1608 1/10W F 2.2k Ω	RTW2201HH008
 <p>← Make sure to use this IC202 with R226 (330 Ω) and R244 (2.2k Ω).</p>		

TYPE A

PARTS LIST [LC320SS2 (Serial No.: DS1)]

Mechanical Parts

PRODUCT SAFETY NOTE: Products marked with a **▲** have special characteristics important to safety. Before replacing any of these components, read carefully the product safety notice in this service manual. Don't degrade the safety of the product through improper servicing.

NOTE: Parts that are not assigned part numbers (-----) are not available.

Different parts from the original model 32MF301B/F7 (Serial No. : DS1)

Ref. No.	Description	Part No.
A1	FRONT CABINET A17F2UH	1EM226004
A12▲	RATING LABEL A17F2UH	-----
A42	ENERGY GUIDE LABEL A17F2UH	-----
S1	CARTON A17F2UH	1EM434846
X2▲	OWNERS MANUAL A17F2UH	1EMN27703
X3	REMOTE CONTROL NH210UD	NH210UD
X6	QUICK START GUIDE A17F2UH	1EMN27704
X7	REGISTRATION CARD (SYLVANIA) A017DUH	1EMN27080

Electrical Parts

PRODUCT SAFETY NOTE: Products marked with a **▲** have special characteristics important to safety. Before replacing any of these components, read carefully the product safety notice in this service manual. Don't degrade the safety of the product through improper servicing.

NOTES:

1. Parts that are not assigned part numbers (-----) are not available.
2. Tolerance of Capacitors and Resistors are noted with the following symbols.

C.....±0.25% D.....±0.5% F.....±1%
G.....±2% J.....±5% K.....±10%
M.....±20% N.....±30% Z.....+80/-20%

Different parts from the original model 32MF301B/F7 (Serial No. : DS1)

Ref. No.	Description	Part No.
	DIGITAL ASSEMBLY Consists of the following	A17F2MMA-003
	DIGITAL MAIN CBA UNIT	A17F2MMA-003-DM
	FUNCTION CBA UNIT	A17F2MMA-003-FN
	IR SENSOR CBA UNIT	A17F2MMA-003-IR

32MF301B/F7(A17F0UH)(Serial No.: DS2)

		20110421	
		32MF301B/F7(A17F0UH)(Serial No.: DS2)	
Different parts from the original model 32MF301B/F7(DS1)			
Ref. No.		Description	Parts No.
MECHANICAL PARTS			
A1		FRONT CABINET A17F0UH	1EM226003A
A2		REAR CABINET A17F1UH	1EM027006A
AC600!		AC CORD W/O A GND WIRE UL/CSA/1730/NO/BLACK	WAC1720LW006
B63		Not used	
CL3101		WIRE ASSEMBLY 2PIN 2PIN/250MM/BLACK RED	WX1A17F1T207
ELECTRICAL PARTS			
		POWER SUPPLY CBA	A17F1MPWA002
CN600!		Not used	
CN601!		CONNECTOR B2P3-VH(LF)(SN)	J3VH020JG001

		20110414	
		LC320EM2(A17F1UH)(Serial No.: DS3)	
Different parts from the original model 32MF301B/F7(DS1)			
Ref. No.		Description	Parts No.
MECHANICAL PARTS			
A1		FRONT CABINET A17F1UH	1EM027005A
A2		REAR CABINET A17F1UH	1EM027006A
A12!		RATING LABEL A17F1UH	-----
A42		ENERGY GUIDE LABEL A17F1UH	-----
AC600!		AC CORD W/O A GND WIRE UL/CSA/1730/NO/BLACK	WAC1720LW006
B63		Not used	
CL3101		WIRE ASSEMBLY 2PIN 2PIN/250MM/BLACK RED	WX1A17F1T207
S1		CARTON A17F1UH	1EM330221
X2!		OWNERS MANUAL A17F1UH	1EMN27479
X3		REMOTE CONTROL NH001UD	NH001UD
X6		QUICK START GUIDE A17F1UH	1EMN27480
X7		REGISTRATION CARD (EMERSON) A17N1UH	1EMN27763
ELECTRICAL PARTS			
		DIGITAL ASSEMBLY	A17F1MMA-006
		Consists of the following	
		DIGITAL MAIN CBA UNIT	A17F1MMA-006-DM
		FUNCTION CBA UNIT	A17F1MMA-006-FN
		IR SENSOR CBA UNIT	A17F1MMA-006-IR
		POWER SUPPLY CBA	A17F1MPWA002
CN600!		Not used	
CN601!		CONNECTOR B2P3-VH(LF)(SN)	J3VH020JG001

		20110414	
		LC320SS2(A17F2UH)(Serial No.: DS2)	
Different parts from the original model 32MF301B/F7(DS1)			
Ref. No.		Description	Parts No.
MECHANICAL PARTS			
A1		FRONT CABINET A17F2UH	1EM226004A
A2		REAR CABINET A17F1UH	1EM027006A
A12!		RATING LABEL A17F2UH	-----
A42		ENERGY GUIDE LABEL A17F2UH	-----
AC600!		AC CORD W/O A GND WIRE UL/CSA/1730/NO/BLACK	WAC1720LW006
B63		Not used	
CL3101		WIRE ASSEMBLY 2PIN 2PIN/250MM/BLACK RED	WX1A17F1T207
S1		CARTON A17F2UH	1EM434846
X2!		OWNERS MANUAL A17F2UH	1EMN27703
X3		REMOTE CONTROL NH210UD	NH210UD
X6		QUICK START GUIDE A17F2UH	1EMN27704
X7		REGISTRATION CARD (SYLVANIA) A017DUH	1EMN27080
ELECTRICAL PARTS			
		DIGITAL ASSEMBLY	A17F2MMA-003
		Consists of the following	
		DIGITAL MAIN CBA UNIT	A17F2MMA-003-DM
		FUNCTION CBA UNIT	A17F2MMA-003-FN
		IR SENSOR CBA UNIT	A17F2MMA-003-IR
		POWER SUPPLY CBA	A17F1MPWA002
CN600!		Not used	
CN601!		CONNECTOR B2P3-VH(LF)(SN)	J3VH020JG001

		20110421	
		LC320EM2(A17F8UT)(Serial No.: TH1)	
Different parts from the original model 32MF301B/F7(DS1)			
Ref. No.	Description	Parts No.	
MECHANICAL PARTS			
	STAND ASSEMBLY A17F8UT	1ESA28630	
A1	FRONT CABINET A17F1UH	1EM027005A	
A2	REAR CABINET A17F1UH	1EM027006A	
A12!	RATING LABEL A17F8UT	-----	
A42	ENERGY GUIDE LABEL A17F1UH	-----	
AC600!	AC CORD W/O A GND WIRE UL/CSA/1730/NO/BLACK	WAC1720LW006	
B11	SPEAKER HOLDER A17F1UH	1EM126473	
B27	Not used		
B63	Not used		
B64	Not used		
B66	Not used		
B67	Not used		
B72	Not used		
CL3101	WIRE ASSEMBLY 2PIN 2PIN/250MM/BLACK RED	WX1A17F1T207	
L28	STAND SCREW KIT A17F8UT	1ESA28631	
L42	SHOULDER SCREW A01Q0UF	1EM328277	
SP3801	SPEAKER MAGNETIC S0412F28E	DS08130XQ004	
SP3802	SPEAKER MAGNETIC S0412F28E	DS08130XQ004	
S1	CARTON A17F8UT	1EM331060	
S7	STAND BAG A01FKUT	1EM432498	
X2!	OWNERS MANUAL A17F8UT	1EMN28127	
X3	REMOTE CONTROL NH001UD	NH001UD	
X6	QUICK START GUIDE A17F8UT	1EMN28128	
X7	REGISTRATION CARD (EMERSON) A17N8UT	1EMN28129	
ELECTRICAL PARTS			
	DIGITAL ASSEMBLY	A17F8MMA-002	
	Consists of the following		
	DIGITAL MAIN CBA UNIT	A17F8MMA-002-DM	
	FUNCTION CBA UNIT	A17F8MMA-002-FN	
	IR SENSOR CBA UNIT	A17F8MMA-002-IR	
	POWER SUPPLY CBA	A17F8MPW-001	
C600	CAP METALLIZED FILM 0.47UF/250V/K/MPX	CTA474EUR001	
C601	CAP METALLIZED FILM 0.47UF/250V/K/MPX	CTA474EUR001	
C602	CAP ELECTROLYTIC 390UF/200V	CEB391DYG006	
C603	Not used		
C604	Not used		
CN600!	Not used		
CN601!	CONNECTOR B2P3-VH(LF)(SN)	J3VH020JG001	
B41	HEAT SINK PNB ASSEMBLY A01FNUT	1EM432598	

REVISION HISTORY

Chassis FL11.4

- 2011-02-08 LC320EM2 (Serial No. : DS1) added
- 2011-03-16 32MF301B/F7 (Serial No. : DS1) added
- 2011-03-16 LC320SS2 (Serial No. : DS1) added
- TBD 32MF301B/F7 (Serial No. : TH1) added
- TBD LC320SS2 (Serial No. : TH1) added
- TBD 32MF301B/F7 (Serial No. : DS2) added
- TBD LC320EM2 (Serial No. : DS3) added
- TBD LC320SS2 (Serial No. : DS2) added
- TBD LC320EM2 (Serial No. : TH1) added

COMPARISON LIST OF MODEL NAME

Chassis FL11.4

32MF301B/F7	(DS1)	A17F0UH
	(DS2)	A17F0UH
	(TH1)	A17FAUT
LC320EM2	(DS1)	A17F1UH
	(DS3)	A17F1UH
	(TH1)	A17F8UT
LC320SS2	(DS1)	A17F2UH
	(DS2)	A17F2UH
	(TH1)	A17FBUT