



LC320EUD

Product Specification

## SPECIFICATION FOR APPROVAL

- Preliminary Specification  
 Final Specification

Title	32.0" WUXGA TFT LCD
-------	---------------------

SUPPLIER	LG Display Co., Ltd.
*MODEL	LC320EUD
SUFFIX	SDF3

\*When you obtain standard approval,  
please use the above model name without suffix

APPROVED BY	SIGNATURE DATE
/	
/	
/	

Please return 1 copy for your confirmation with  
your signature and comments.

APPROVED BY	SIGNATURE DATE
<b>W.G. Youn / Team Leader</b>	
<b>REVIEWED BY</b>	
<b>J.H. Lee / Project Leader</b>	
<b>PREPARED BY</b>	
<b>W.J. Choi / Engineer</b>	

**Public Display Development  
LG Display Co., Ltd**

LC320EUD

## Product Specification

**CONTENTS**

Number	ITEM	Page
	COVER	1
	CONTENTS	2
	RECORD OF REVISIONS	3
1	GENERAL DESCRIPTION	4
2	ABSOLUTE MAXIMUM RATINGS	5
3	ELECTRICAL SPECIFICATIONS	6
3-1	ELECTRICAL CHARACTERISTICS	6
3-2	INTERFACE CONNECTIONS	8
3-3	SIGNAL TIMING SPECIFICATIONS	11
3-4	SIGNAL TIMING WAVEFORMS	12
3-5	COLOR DATA REFERENCE	15
3-6	POWER SEQUENCE	16
4	OPTICAL SPECIFICATIONS	18
5	MECHANICAL CHARACTERISTICS	24
6	RELIABILITY	27
7	INTERNATIONAL STANDARDS	28
7-1	SAFETY	28
7-2	EMC	28
7-3	Environment	28
8	PACKING	29
8-1	DESIGNATION OF LOT MARK	29
8-2	PACKING FORM	29
9	PRECAUTIONS	30
9-1	MOUNTING PRECAUTIONS	30
9-2	OPERATING PRECAUTIONS	30
9-3	ELECTROSTATIC DISCHARGE CONTROL	31
9-4	PRECAUTIONS FOR STRONG LIGHT EXPOSURE	31
9-5	STORAGE	31
9-6	HANDLING PRECAUTIONS FOR PROTECTION FILM	31

Ver.1.0

2 / 43



LC320EUD

## Product Specification

## 1. General Description

The LC320EUD is a Color Active Matrix Liquid Crystal Display with an integral Light Emitting Diode (LED) backlight system. The matrix employs a-Si Thin Film Transistor as the active element. It is a transmissive display type which is operating in the normally black mode. It has a 46.96 inch diagonally measured active display area with WUXGA resolution (1080 vertical by 1920 horizontal pixel array). Each pixel is divided into Red, Green and Blue sub-pixels or dots which are arrayed in vertical stripes. Gray scale or the luminance of the sub-pixel color is determined with a 10-bit gray scale signal for each dot. Therefore, it can present a palette of more than 1.06Billion colors.

It has been designed to apply the 10-bit 4-port LVDS interface.

It is intended to support LCD TV, PCTV where high brightness, super wide viewing angle, high color gamut, high color depth and fast response time are important.

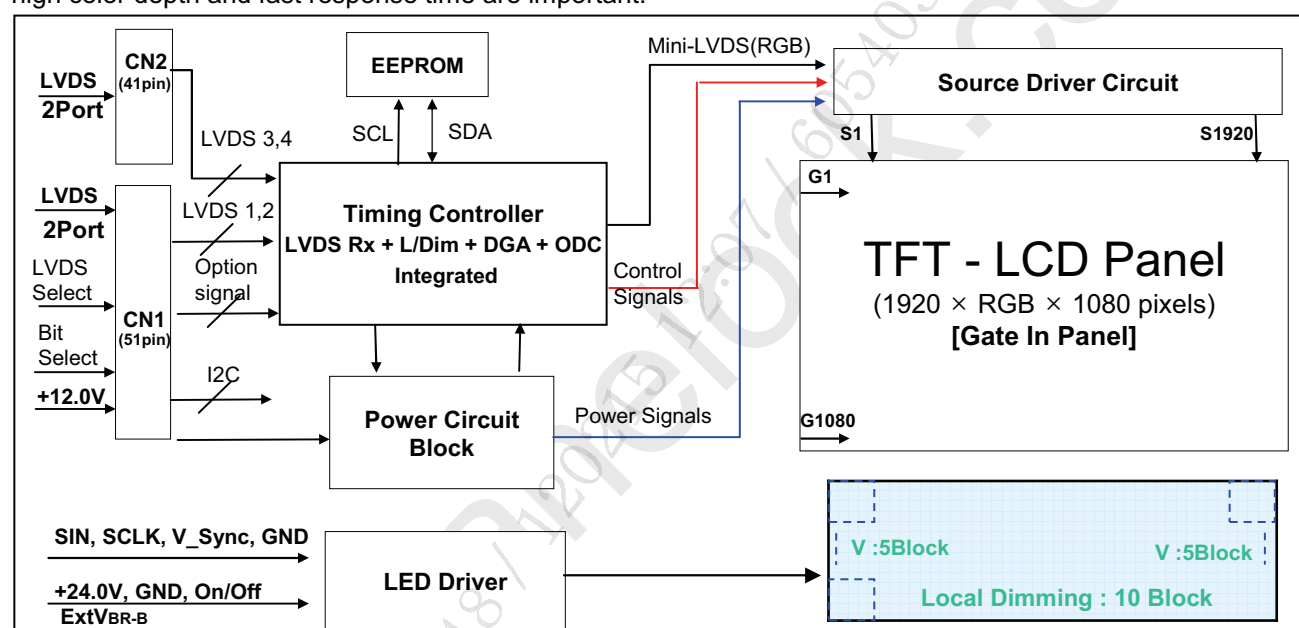

## General Features

Active Screen Size	31.55 inch (801.31mm) diagonal
Outline Dimension	698.40(H) x 392.85 (V) x 10.8(B) / 24.0 mm (D) (Typ.)
Pixel Pitch	0.36375 mm x 0.36375 mm x RGB
Pixel Format	1920 horiz. by 1080 vert. Pixels, RGB stripe arrangement
Color Depth	10Bit(D), 1.06 Billion colors
Luminance, White	400 cd/m <sup>2</sup> (Center 1point ,Typ.)
Viewing Angle (CR>10)	Viewing angle free ( R/L 178 (Min.), U/D 178 (Min.))
Power Consumption	Total 67.8W(Typ.) [Logic= 6.7W, Backlight=61.1W (ExtVbr_B=100% )]
Weight	4.8 Kg (Typ.)
Display Mode	Transmissive mode, Normally black
Surface Treatment	Hard coating(2H), Anti-glare treatment of the front polarizer (Haze 10%)

Ver.1.0

4 / 43

## Product Specification

## 2. Absolute Maximum Ratings

The following items are maximum values which, if exceeded, may cause faulty operation or **permanent** damage to the LCD module.

**Table 1. ABSOLUTE MAXIMUM RATINGS**

Parameter		Symbol	Value		Unit	Note
			Min	Max		
Power Input Voltage	LCD Circuit	VLCD	-0.3	+14.0	VDC	
	Driver	VBL	-0.3	+ 27.0	VDC	
Driver Control Voltage	ON/OFF	V <sub>OFF</sub> / V <sub>ON</sub>	-0.3	+5.5	VDC	1
	Brightness	EXTVBR-B	0.0	+5.5	VDC	
T-Con Option Selection Voltage		V <sub>LOGIC</sub>	-0.3	+4.0	VDC	
Operating Temperature		T <sub>OP</sub>	0	+50	°C	2,3
Storage Temperature		T <sub>ST</sub>	-20	+60	°C	
Panel Front Temperature		T <sub>SUR</sub>	-	+68	°C	4
Operating Ambient Humidity		H <sub>OP</sub>	10	90	%RH	2,3
Storage Humidity		H <sub>ST</sub>	10	90	%RH	

Note1. Ambient temperature condition ( $T_a = 25 \pm 2 \text{ }^\circ\text{C}$ )

2. Temperature and relative humidity range are shown in the figure below.

Wet bulb temperature should be Max 39°C, and no condensation of water.

3. Gravity mura can be guaranteed below 40°C condition.

4. The maximum operating temperatures is based on the test condition that the surface temperature of display area is less than or equal to 68°C with LCD module alone in a temperature controlled chamber. Thermal management should be considered in final product design to prevent the surface temperature of display area from being over 68°C. The range of operating temperature may be degraded in case of improper thermal management in final product design.

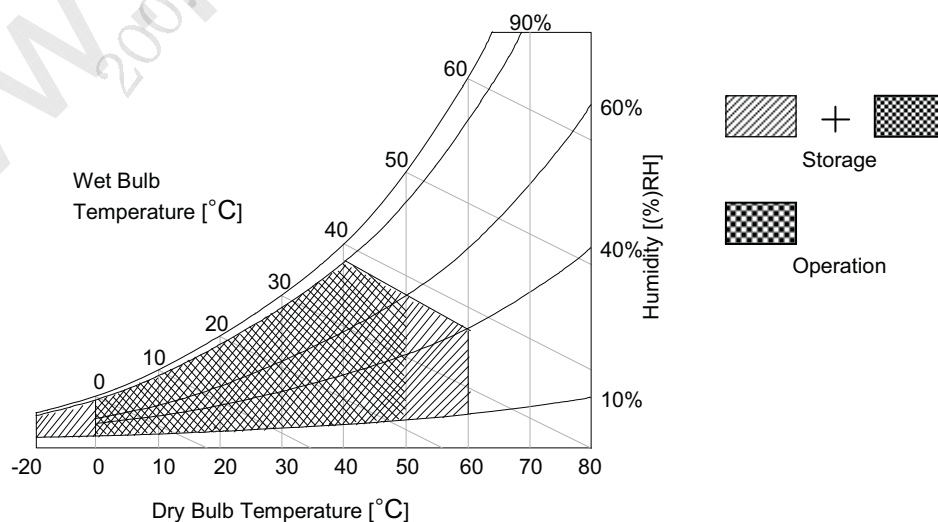

LC320EUD

## Product Specification

## 3. Electrical Specifications

## 3-1. Electrical Characteristics

It requires two power inputs. One is employed to power for the LCD circuit.

The other is used for the LED backlight circuit.

Table 2. ELECTRICAL CHARACTERISTICS

Parameter	Symbol	Value			Unit	Note
		Min	Typ	Max		
<b>Circuit :</b>						
Power Input Voltage	$V_{LCD}$	10.8	12.0	13.2	$V_{DC}$	
Power Input Current	$I_{LCD}$	-	560	728	mA	1
		-	825	1073	mA	2
Power Consumption	$P_{LCD}$	-	6.7	8.7	Watt	1
Rush current	$I_{RUSH}$	-	-	5.0	A	3

Note : 1. The specified current and power consumption are under the  $V_{LCD}=12.0V$ ,  $25 \pm 2^{\circ}C$ ,  $f_V=120Hz$  condition whereas mosaic pattern(8 x 6) is displayed and  $f_V$  is the frame frequency.

2. The current is specified at maximum current pattern.

3. The duration of rush current is about 2ms and rising time of power input is 0.5ms (min.).

White : 1023 Gray

Black : 0 Gray

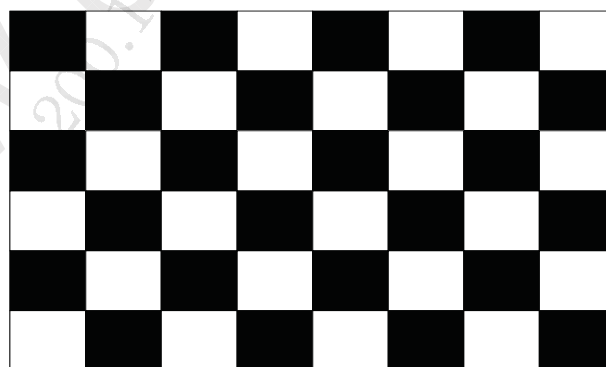

Mosaic Pattern(8 x 6)

LC320EUD

## Product Specification

Table 3. ELECTRICAL CHARACTERISTICS (Continue)

Parameter	Symbol	Values			Unit	Notes			
		Min	Typ	Max					
LED Driver :									
Power Supply Input Voltage	VBL	22.8	24.0	25.2	Vdc	1			
Power Supply Input Current	IBL	-	2.55	2.78	A	1			
Power Supply Input Current (In-Rush)	In-rush	-	-	4.5	A	VBL = 22.8V Ext VBR-B = 100% 4			
Power Consumption	PBL	-	61.1	66.8	W	1			
Input Voltage for Control System Signals	On/Off	On	V on	2.5	-	5.0	Vdc	On Duty 6	
		Off	V off	-0.3	0.0	0.7	Vdc		
	Brightness Adjust	ExtVBR-B	1	-	100	%			
		PWM Frequency for NTSC & PAL	PAL		100		Hz		3
		NTSC		120			Hz		3
	Pulse Duty Level (PWM)	High Level	2.5	-	5.0	Vdc	HIGH : on duty LOW : off duty		
Low Level		0.0	-	0.7	Vdc				
LED :									
Life Time		30,000			Hrs	2			

## Notes :

- Electrical characteristics are determined after the unit has been 'ON' and stable for approximately 60 minutes at  $25\pm 2^{\circ}\text{C}$ . The specified current and power consumption are under the typical supply Input voltage 24V and VBR (ExtVBR-B : 100%), it is total power consumption.
- The life time (MTTF) is determined as the time which luminance of the LED is 50% compared to that of initial value at the typical LED current (ExtVBR-B : 100%) on condition of continuous operating in LCM state at  $25\pm 2^{\circ}\text{C}$ .
- LGD recommend that the PWM freq. is synchronized with One time harmonic of V\_sync signal of system. Though PWM frequency is over 120Hz (max 252Hz), function of LED Driver is not affected.
- The duration of rush current is about 200ms.
- Even though inrush current is over the specified value, there is no problem if I<sup>2</sup>T spec of fuse is satisfied.
- Ext\_PWM Signal have to input available duty range.  
Between 99% and 100% ExtVBR-B duty have to be avoided. ( 99% < ExtVBR-B < 100%)  
But ExtVBR-B 0% and 100% is possible.



## Product Specification

**3-2. Interface Connections**

This LCD module employs two kinds of interface connection, 51-pin connector and 41-pin connector are used for the module electronics and 14-pin connector is used for the integral backlight system.

**3-2-1. LCD Module**

- LCD Connector(CN1): FI-R51S-HF(manufactured by JAE) or compatible  
Refer to below and next Page table
- Mating Connector : FI-R51HL(JAE) or compatible

**Table 4-1. MODULE CONNECTOR(CN1) PIN CONFIGURATION**

No	Symbol	Description	No	Symbol	Description
1	NC	No Connection	27	Bit Select	'H' or NC= 10bit(D) , 'L' = 8bit
2	NC	No Connection	28	R2AN	SECOND LVDS Receiver Signal (A-)
3	NC	No Connection	29	R2AP	SECOND LVDS Receiver Signal (A+)
4	NC	No Connection	30	R2BN	SECOND LVDS Receiver Signal (B-)
5	NC	No Connection	31	R2BP	SECOND LVDS Receiver Signal (B+)
6	NC	No Connection (Note 4)	32	R2CN	SECOND LVDS Receiver Signal (C-)
7	LVDS Select	'H' =JEIDA , 'L' or NC = VESA	33	R2CP	SECOND LVDS Receiver Signal (C+)
8	NC	No Connection (Note 4)	34	GND	Ground
9	NC	No Connection (Note 4)	35	R2CLKN	SECOND LVDS Receiver Clock Signal(-)
10	NC	No Connection (Note 4)	36	R2CLKP	SECOND LVDS Receiver Clock Signal(+)
11	GND	Ground	37	GND	Ground
12	R1AN	FIRST LVDS Receiver Signal (A-)	38	R2DN	SECOND LVDS Receiver Signal (D-)
13	R1AP	FIRST LVDS Receiver Signal (A+)	39	R2DP	SECOND LVDS Receiver Signal (D+)
14	R1BN	FIRST LVDS Receiver Signal (B-)	40	R2EN	SECOND LVDS Receiver Signal (E-)
15	R1BP	FIRST LVDS Receiver Signal (B+)	41	R2EP	SECOND LVDS Receiver Signal (E+)
16	R1CN	FIRST LVDS Receiver Signal (C-)	42	NC	No Connection
17	R1CP	FIRST LVDS Receiver Signal (C+)	43	NC	No Connection
18	GND	Ground	44	GND	Ground
19	R1CLKN	FIRST LVDS Receiver Clock Signal(-)	45	GND	Ground
20	R1CLKP	FIRST LVDS Receiver Clock Signal(+)	46	GND	Ground
21	GND	Ground	47	NC	No connection
22	R1DN	FIRST LVDS Receiver Signal (D-)	48	VLCD	Power Supply +12.0V
23	R1DP	FIRST LVDS Receiver Signal (D+)	49	VLCD	Power Supply +12.0V
24	R1EN	FIRST LVDS Receiver Signal (E-)	50	VLCD	Power Supply +12.0V
25	R1EP	FIRST LVDS Receiver Signal (E+)	51	VLCD	Power Supply +12.0V
26	NC	No Connection	-	-	-

- Note
1. All GND(ground) pins should be connected together to the LCD module's metal frame.
  2. All VLCD (power input) pins should be connected together.
  3. All Input levels of LVDS signals are based on the **EIA 644** Standard.
  4. #1~#6 & #8~#9 NC (No Connection): These pins are used only for LGD (Do not connect)
  5. Specific pins(pin No. **#10**) are used for Local Dimming function of the LCD module.  
If not used, these pins are no connection. (Please see the **Appendix V** for more information.)
  6. LVDS pin (pin No. **#24,25,40,41**) are used for 10Bit(D) of the LCD module.  
If used for 8Bit(R), these pins are no connection.
  7. Specific pin No. **#44** is used for "No signal detection" of system signal interface.  
It should be GND for NSB(No Signal Black) during the system interface signal is not.  
If this pin is "H", LCD Module displays AGP(Auto Generation Pattern).
  8. Specific pin (pin No. **#4, #5**) is used for Controlling Local Dimming's register in the LCM Module.



LC320EUD

## Product Specification

- LCD Connector (CN2) : FI-RE41S-HF (manufactured by JAE) or compatible
- Mating Connector : FI-RE41HL

Table 4-2. MODULE CONNECTOR(CN2) PIN CONFIGURATION

No	Symbol	Description	No	Symbol	Description
1	NC	No connection	22	RE3N	THIRD LVDS Receiver Signal (E-)
2	NC	No connection	23	RE3P	THIRD LVDS Receiver Signal (E+)
3	NC	No connection	24	GND	Ground
4	NC	No connection	25	GND	Ground
5	NC	No connection	26	RA4N	FORTH LVDS Receiver Signal (A-)
6	NC	No connection	27	RA4P	FORTH LVDS Receiver Signal (A+)
7	NC	No connection	28	RB4N	FORTH LVDS Receiver Signal (B-)
8	NC	No connection	29	RB4P	FORTH LVDS Receiver Signal (B+)
9	GND	Ground	30	RC4N	FORTH LVDS Receiver Signal (C-)
10	RA3N	THIRD LVDS Receiver Signal (A-)	31	RC4P	FORTH LVDS Receiver Signal (C+)
11	RA3P	THIRD LVDS Receiver Signal (A+)	32	GND	Ground
12	RB3N	THIRD LVDS Receiver Signal (B-)	33	RCLK4N	FORTH LVDS Receiver Clock Signal(-)
13	RB3P	THIRD LVDS Receiver Signal (B+)	34	RCLK4P	FORTH LVDS Receiver Clock Signal(+)
14	RC3N	THIRD LVDS Receiver Signal (C-)	35	GND	Ground
15	RC3P	THIRD LVDS Receiver Signal (C+)	36	RD4N	FORTH LVDS Receiver Signal (D-)
16	GND	Ground	37	RD4P	FORTH LVDS Receiver Signal (D+)
17	RCLK3N	THIRD LVDS Receiver Clock Signal(-)	38	RE4N	FORTH LVDS Receiver Signal (E-)
18	RCLK3P	THIRD LVDS Receiver Clock Signal(+)	39	RE4P	FORTH LVDS Receiver Signal (E+)
19	GND	Ground	40	GND	Ground
20	RD3N	THIRD LVDS Receiver Signal (D-)	41	GND	Ground
21	RD3P	THIRD LVDS Receiver Signal (D+)	-		

- Note :
1. All GND(ground) pins should be connected together to the LCD module's metal frame.
  2. LVDS pin (**pin No. #22,23,38,39**) are used for 10Bit(D) of the LCD module.  
If used for 8Bit(R), these pins are no connection.

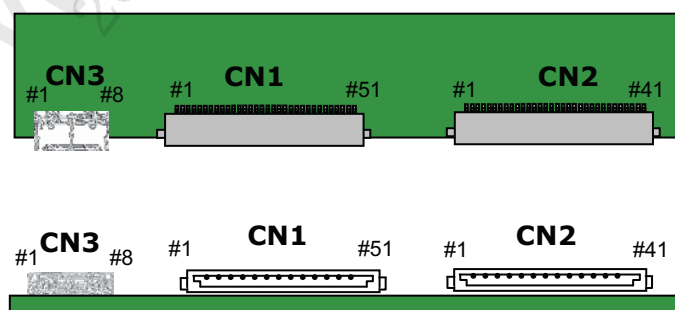

Rear view of LCM

LC320EUD

## Product Specification

## 3-2-2. Backlight Module

Master

-LED Driver Connector

: 20022WR - H14B1(Yeonho)

- Mating Connector

: 20022HS - 14B2

Table 5. LED DRIVER CONNECTOR PIN CONFIGURATION

Pin No	Symbol	Description	Note
1	VBL	Power Supply +24.0V	
2	VBL	Power Supply +24.0V	
3	VBL	Power Supply +24.0V	
4	VBL	Power Supply +24.0V	
5	VBL	Power Supply +24.0V	
6	GND	Backlight Ground	1
7	GND	Backlight Ground	
8	GND	Backlight Ground	
9	GND	Backlight Ground	
10	GND	Backlight Ground	
11	Status	Back Light Status	
12	VON/OFF	Backlight ON/OFF control	
13	NC	Don't care	
14	EXTVBR-B	External PWM	2

Notes : 1. GND should be connected to the LCD module's metal frame.

2. Normal : Low (under 0.7V) / Abnormal : High (upper 3.0V)

3. High : on duty / Low : off duty, Pin#14 can be opened. ( if Pin #14 is open , EXTVBR-B is 100% )

4. Each impedance of pin #12 and 14 is over 50 [KΩ] .

## ◆ Rear view of LCM

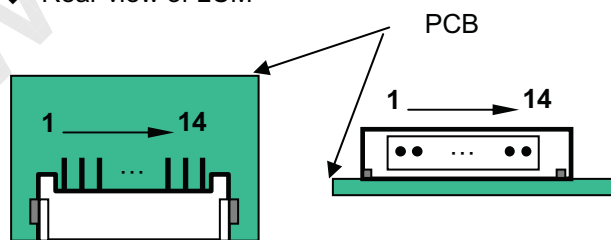

&lt;Master&gt;

LC320EUD

## Product Specification

**3-2-3. Local Dimming Interface**

- Local Dimming Interface Connector : 12507WR-H08L(YEONHO Elec.) or Equivalent

- Mating Connector: 12507HS-08L(YEONHO Elec.) or Equivalent

**Table 5-2. LOCAL DIMMING INTERFACE CONNECTOR PIN CONFIGURATION**

Pin No	Symbol	Description	Note
1	VSYNC	Vertical Sync signal	
2	SDA	I2C Data for MCU F/W Download	
3	SCL	I2C Clock for MCU F/W Download	
4	SIN	Local Dimming Serial Data (SPI)	
5	GND	Backlight Ground	1
6	SCLK	Local Dim Serial Clock (SPI)	
7	N.C	No Connection	3
8	Reverse	Local Dimming data for reverse	2

Notes : 1. GND should be connected to the LCD module's metal frame.

2. High or N.C : Local Dimming data for reverse mode

Low : Local Dimming data for non-reverse mode

3. This pin is used only for LGD (Do not connect)

8Pin Reverse Pin	SPI Command 7 Bit	Result
Low	Low	Non-reverse mode
Low	High	Reverse mode
High	Low	Reverse mode
High	High	Reverse mode

## ◆ Rear view of LCM

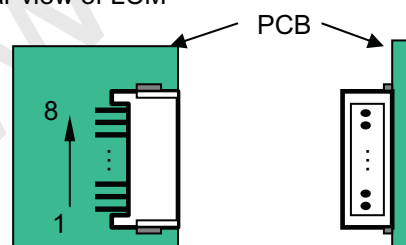

LC320EUD

## Product Specification

**3-3. Signal Timing Specifications**

Table 6 shows the signal timing required at the input of the LVDS transmitter. All of the interface signal timings should be satisfied with the following specification for normal operation.

**Table 6. TIMING TABLE (DE Only Mode)**

ITEM		Symbol	Min	Typ	Max	Unit	Note
Horizontal	Display Period	tHV	480	480	480	tCLK	1920 / 4
	Blank	tHB	40	70	200	tCLK	1
	Total	tHP	520	550	680	tCLK	
Vertical	Display Period	tVv	1080	1080	1080	Lines	
	Blank	tVB	20 (228)	45 (270)	86 (300)	Lines	1
	Total	tVP	1100 (1308)	1125 (1350)	1166 (1380)	Lines	

ITEM		Symbol	Min	Typ	Max	Unit	Note
Frequency	DCLK	fCLK	66.97	74.25	78.00	MHz	
	Horizontal	fH	121.8	135	140	KHz	2
	Vertical	fV	108 (95)	120 (100)	122 (104)	Hz	2 NTSC : 108~122Hz (PAL : 95~104Hz)

- Note
1. The Input of HSYNC & VSYNC signal does not have an effect on normal operation(DE Only Mode). If you use spread spectrum for EMI, add some additional clock to minimum value for clock margin.
  2. The performance of the electro-optical characteristics may be influenced by variance of the vertical refresh rate and the horizontal frequency.
  3. Timing should be set based on clock frequency.

Product Specification

3-4. LVDS Signal Specification

3-4-1. LVDS Input Signal Timing Diagram

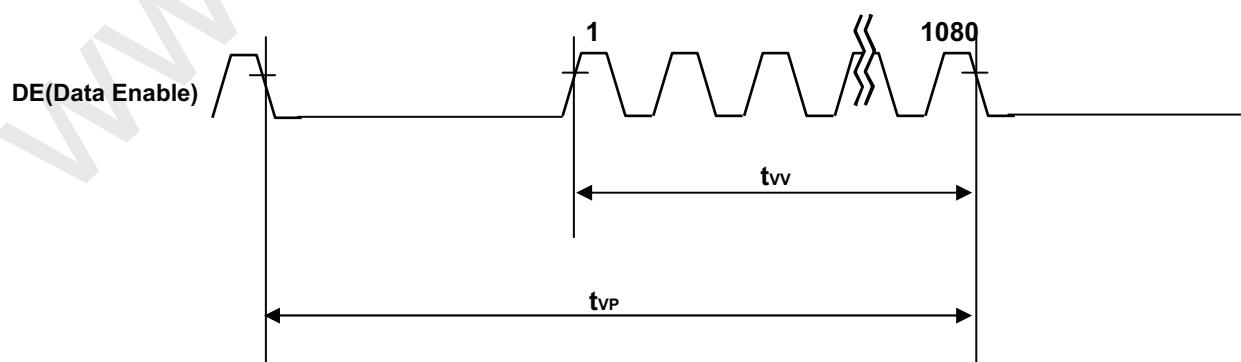
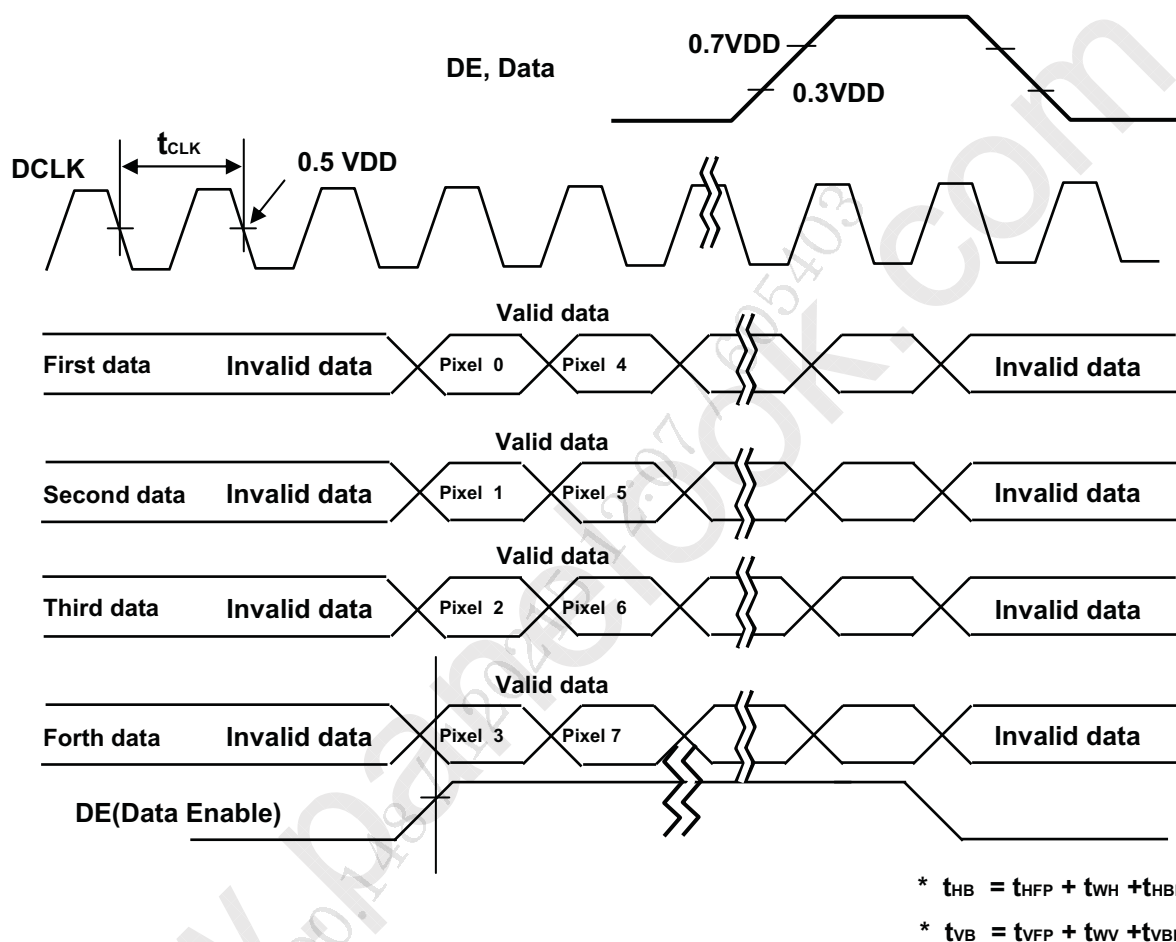

Product Specification

3-4-2. LVDS Input Signal Characteristics

1) DC Specification

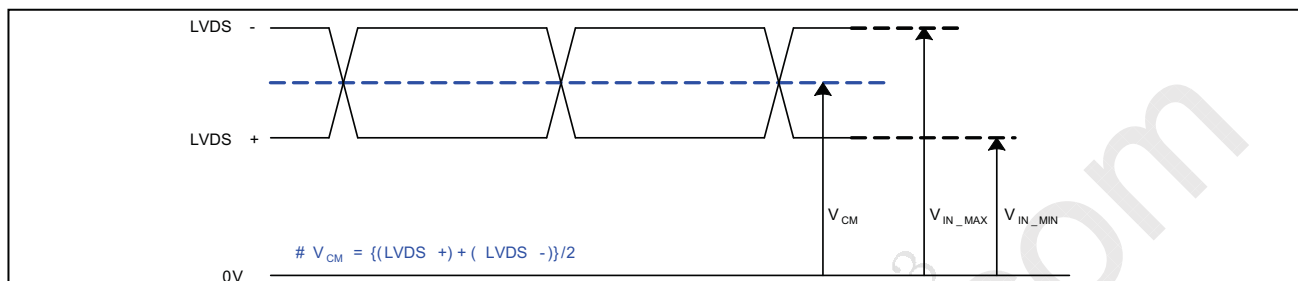

Description	Symbol	Min	Max	Unit	Note
LVDS Common mode Voltage	$V_{CM}$	1.0	1.5	V	-
LVDS Input Voltage Range	$V_{IN}$	0.7	1.8	V	-
Change in common mode Voltage	$\Delta V_{CM}$		250	mV	-

2) AC Specification

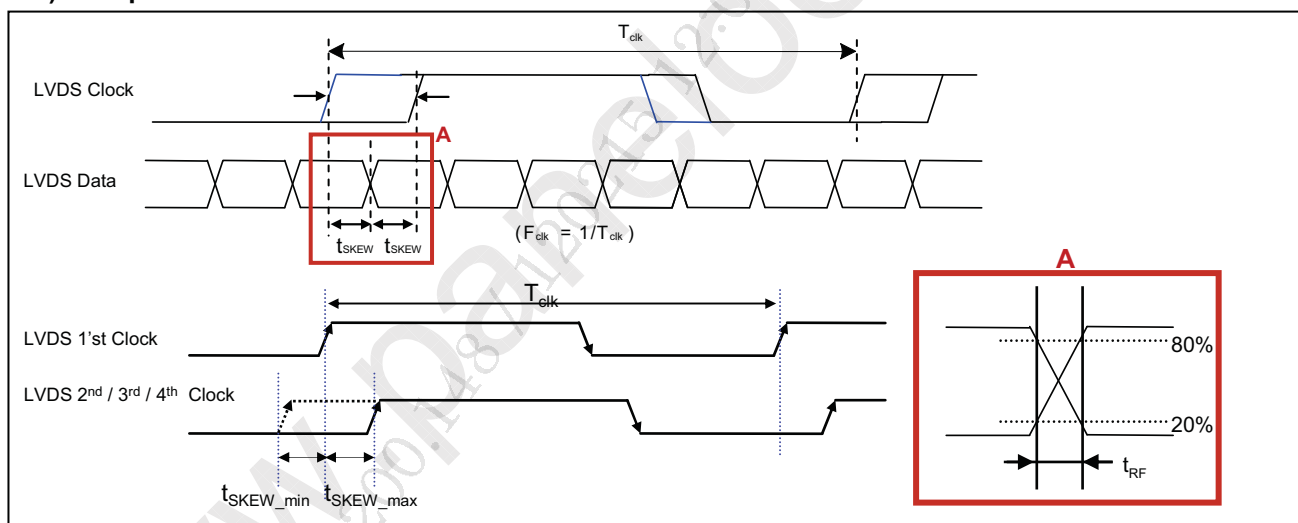

Description	Symbol	Min	Max	Unit	Note	
LVDS Differential Voltage	High Threshold	$V_{TH}$	100	300	mV	3
	Low Threshold	$V_{TL}$	-300	-100	mV	
LVDS Clock to Data Skew Margin	$t_{SKEW}$		$ (0.25 \cdot T_{clk})/7 $	ps	-	
LVDS Clock/DATA Rising/Falling time	$t_{RF}$	260	$(0.3 \cdot T_{clk})/7$	ps	2	
Effective time of LVDS	$t_{eff}$	$\pm 360$		ps	-	
LVDS Clock to Clock Skew Margin (Even to Odd)	$t_{SKEW\_EO}$		$1/7 \cdot T_{clk}$	$T_{clk}$	-	

- Note
1. All Input levels of LVDS signals are based on the EIA 644 Standard.
  2. If  $t_{RF}$  isn't enough,  $t_{eff}$  should meet the range.
  3. LVDS Differential Voltage is defined within  $t_{eff}$



LC320EUD

Product Specification

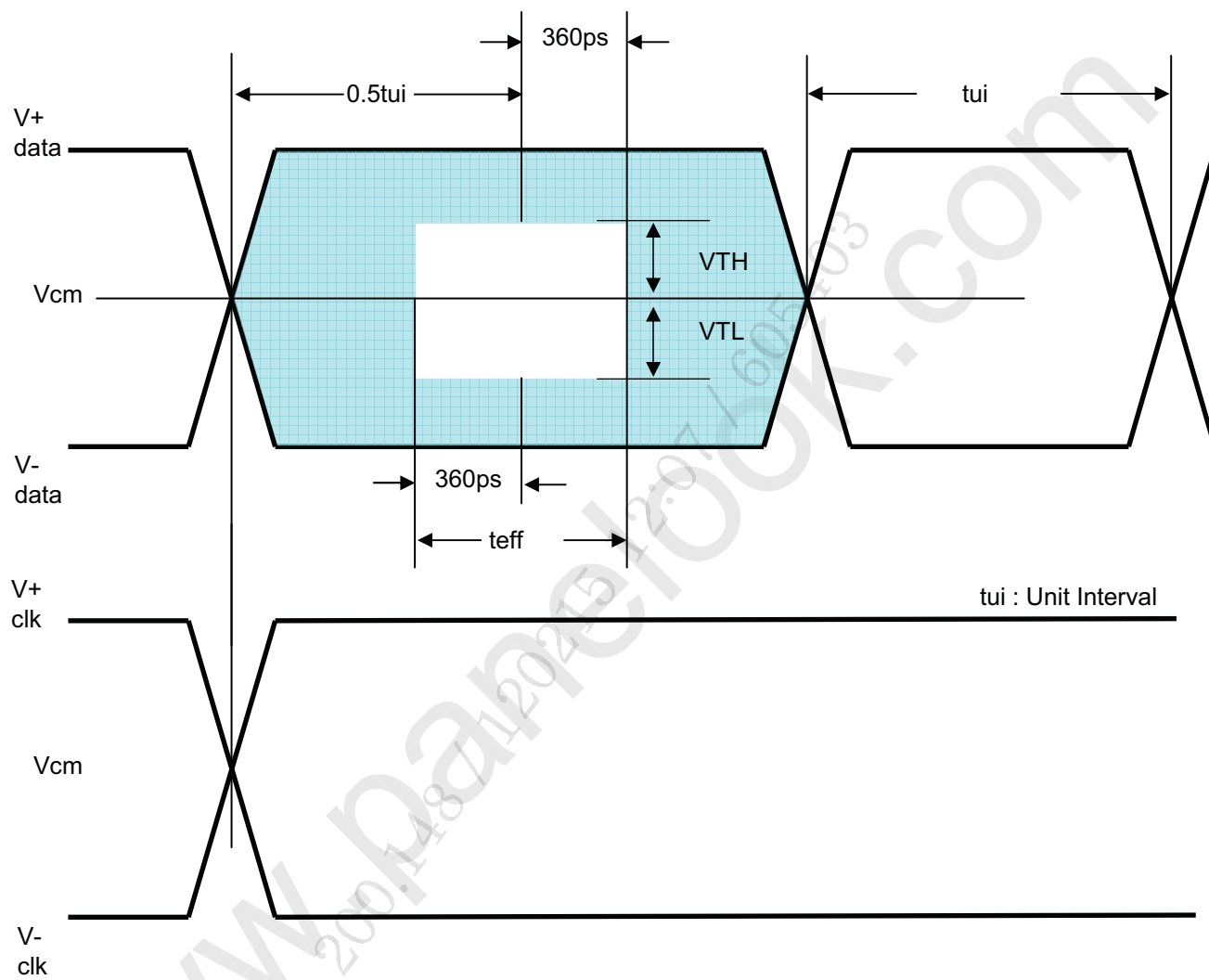

Product Specification

3-5. Color Data Reference

The brightness of each primary color(red,green,blue) is based on the 10-bit gray scale data input for the color. The higher binary input, the brighter the color. Table 8 provides a reference for color versus data input.

Table 8. COLOR DATA REFERENCE

Color		Input Color Data																													
		RED										GREEN										BLUE									
		MSB	LSB									MSB	LSB									MSB	LSB								
		R9	R8	R7	R6	R5	R4	R3	R2	R1	R0	G9	G8	G7	G6	G5	G4	G3	G2	G1	G0	B9	B8	B7	B6	B5	B4	B3	B2	B1	B0
Basic Color	Black	0	0	0	0	0	0	0	0	0	0	0	0	0	0	0	0	0	0	0	0	0	0	0	0	0	0	0	0	0	0
	Red (1023)	1	1	1	1	1	1	1	1	1	1	0	0	0	0	0	0	0	0	0	0	0	0	0	0	0	0	0	0	0	0
	Green (1023)	0	0	0	0	0	0	0	0	0	0	1	1	1	1	1	1	1	1	1	1	0	0	0	0	0	0	0	0	0	0
	Blue (1023)	0	0	0	0	0	0	0	0	0	0	0	0	0	0	0	0	0	0	0	0	1	1	1	1	1	1	1	1	1	1
	Cyan	0	0	0	0	0	0	0	0	0	0	1	1	1	1	1	1	1	1	1	1	1	1	1	1	1	1	1	1	1	1
	Magenta	1	1	1	1	1	1	1	1	1	1	0	0	0	0	0	0	0	0	0	0	1	1	1	1	1	1	1	1	1	1
	Yellow	1	1	1	1	1	1	1	1	1	1	1	1	1	1	1	1	1	1	1	1	0	0	0	0	0	0	0	0	0	0
	White	1	1	1	1	1	1	1	1	1	1	1	1	1	1	1	1	1	1	1	1	1	1	1	1	1	1	1	1	1	1
RED	RED (000)	0	0	0	0	0	0	0	0	0	0	0	0	0	0	0	0	0	0	0	0	0	0	0	0	0	0	0	0	0	
	RED (001)	0	0	0	0	0	0	0	0	0	0	0	0	0	0	0	0	0	0	0	0	0	0	0	0	0	0	0	0	0	
	...	...	...	...	...	...	...	...	...	...	...	...	...	...	...	...	...	...	...	...	...	...	...	...	...	...	...	...	...		
	RED (1022)	1	1	1	1	1	1	1	1	1	0	0	0	0	0	0	0	0	0	0	0	0	0	0	0	0	0	0	0	0	
	RED (1023)	1	1	1	1	1	1	1	1	1	0	0	0	0	0	0	0	0	0	0	0	0	0	0	0	0	0	0	0	0	
GREEN	GREEN (000)	0	0	0	0	0	0	0	0	0	0	0	0	0	0	0	0	0	0	0	0	0	0	0	0	0	0	0	0	0	
	GREEN (001)	0	0	0	0	0	0	0	0	0	0	0	0	0	0	0	0	0	0	0	0	0	0	0	0	0	0	0	0	0	
	...	...	...	...	...	...	...	...	...	...	...	...	...	...	...	...	...	...	...	...	...	...	...	...	...	...	...	...			
	GREEN (1022)	0	0	0	0	0	0	0	0	0	1	1	1	1	1	1	1	1	1	1	0	0	0	0	0	0	0	0	0	0	
	GREEN (1023)	0	0	0	0	0	0	0	0	0	1	1	1	1	1	1	1	1	1	1	0	0	0	0	0	0	0	0	0	0	
BLUE	BLUE (000)	0	0	0	0	0	0	0	0	0	0	0	0	0	0	0	0	0	0	0	0	0	0	0	0	0	0	0	0	0	
	BLUE (001)	0	0	0	0	0	0	0	0	0	0	0	0	0	0	0	0	0	0	0	0	0	0	0	0	0	0	0	0	1	
	...	...	...	...	...	...	...	...	...	...	...	...	...	...	...	...	...	...	...	...	...	...	...	...	...	...	...	...			
	BLUE (1022)	0	0	0	0	0	0	0	0	0	0	0	0	0	0	0	0	0	0	0	1	1	1	1	1	1	1	1	1	0	
	BLUE (1023)	0	0	0	0	0	0	0	0	0	0	0	0	0	0	0	0	0	0	0	1	1	1	1	1	1	1	1	1	1	



LC320EUD

## Product Specification

## 3-6. Power Sequence

## 3-6-1. LCD Driving circuit

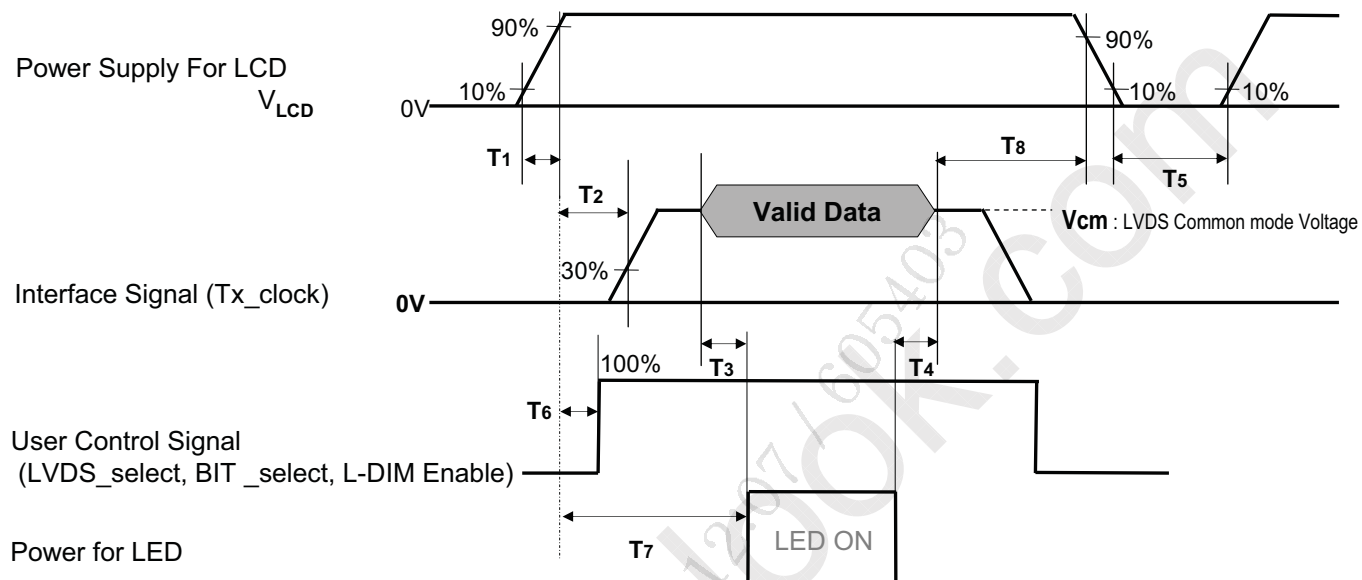

Table 8. POWER SEQUENCE

Parameter	Value			Unit	Notes
	Min	Typ	Max		
T1	0.5	-	20	ms	1
T2	0	-	-	ms	2
T3	200	-	-	ms	3
T4	200	-	-	ms	3
T5	1.0	-	-	s	4
T6	-	-	T2	ms	5
T7	0.5	-	-	s	6
T8	100	-	-	ms	7

- Note :
1. Even though T1 is over the specified value, there is no problem if I2T spec of fuse is satisfied.
  2. If T2 is satisfied with specification after removing LVDS Cable, there is no problem.
  3. The T3 / T4 is recommended value, the case when failed to meet a minimum specification, abnormal display would be shown. There is no reliability problem.
  4. T5 should be measured after the Module has been fully discharged between power off and on period.
  5. If the on time of signals (Interface signal and user control signals) precedes the on time of Power ( $V_{LCD}$ ), it will be happened abnormal display. When T6 is NC status, T6 doesn't need to be measured.
  6. If there is no abnormal display, no problem.
  7. It is recommendation specification that T8 has to be 100ms as a minimum value.
- ※ Please avoid floating state of interface signal at invalid period.  
 ※ When the power supply for LCD (VLCD) is off, be sure to pull down the valid and invalid data to 0V.

Ver.1.0

17 / 43

LC320EUD

## Product Specification

## 3-6-2. Sequence for LED Driver

Power Supply For LED Driver

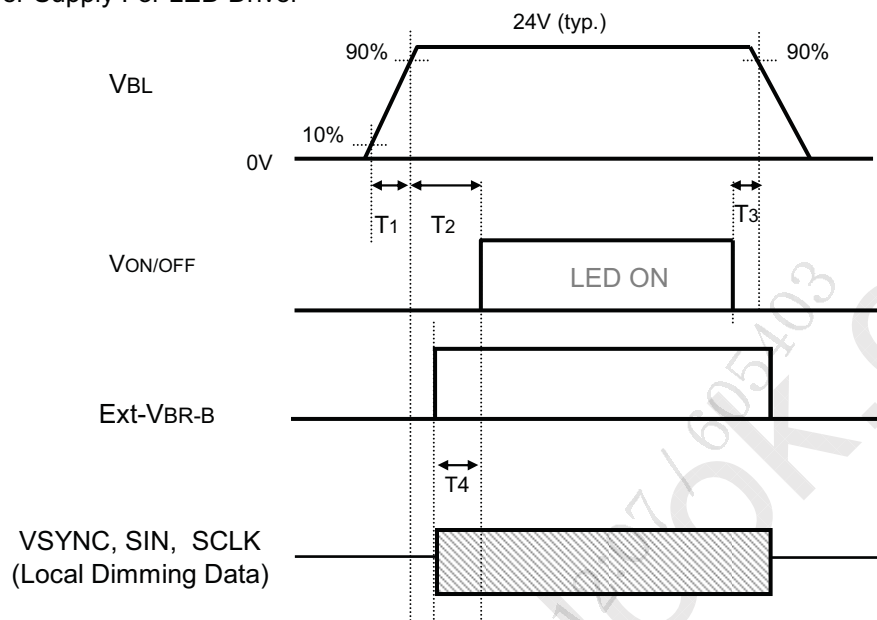

## 3-6-3. Dip condition for LED Driver

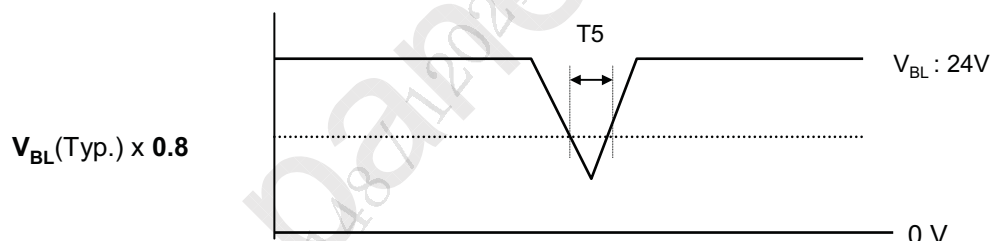

Table 9. Power Sequence for LED Driver

Parameter	Values			Units	Remarks
	Min	Typ	Max		
T1	20	-	-	ms	1
T2	500	-	-	ms	
T3	10	-	-	ms	
T4	0	-	-	ms	
T5	-	-	10	ms	$V_{BL}(Typ) \times 0.8$

Notes : 1. T1 describes rising time of 0V to 24V and this parameter does not applied at restarting time.  
Even though T1 is over the specified value, there is no problem if I<sup>2</sup>T spec of fuse is satisfied.

LC320EUD

## Product Specification

## 4. Optical Specification

Optical characteristics are determined after the unit has been 'ON' and stable in a dark environment at  $25\pm 2^{\circ}\text{C}$ . The values are specified at distance 50cm from the LCD surface at a viewing angle of  $\Phi$  and  $\theta$  equal to  $0^{\circ}$ . FIG. 1 shows additional information concerning the measurement equipment and method.

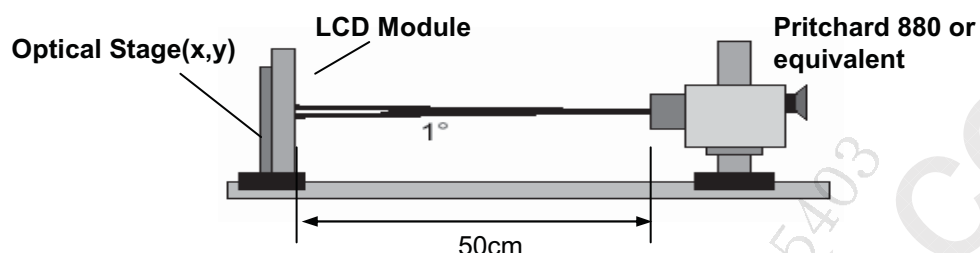

FIG. 1 Optical Characteristic Measurement Equipment and Method

Table 10. OPTICAL CHARACTERISTICS

$T_a = 25\pm 2^{\circ}\text{C}$ ,  $V_{\text{LCD}} = 12.0\text{V}$ ,  $f_v = 120\text{Hz}$ ,  $D_{\text{clk}} = 297\text{MHz}$   
EXTVBR-B=100%

Parameter	Symbol	Value			Unit	Note		
		Min	Typ	Max				
Contrast Ratio	CR	1200	1600	-		1		
Surface Luminance, white	$L_{\text{WH}}$	2D	320	400		cd/m <sup>2</sup>	2	
		3D	120	150				
Luminance Variation	$\delta_{\text{WHITE}}$	5P		1.3		3		
Response Time	Gray-to-Gray	G to G	-	5	8	ms	4	
	MPRT	MPRT	-	6	9		5	
	Uniformity	$\delta_{\text{MPRT}}$	-	-	1		6	
	Uniformity	$\delta_{\text{G TO G}}$	-	-	1		6	
Color Coordinates [CIE1931]	RED	Rx		0.650		Typ +0.03		
		Ry		0.332				
	GREEN	Gx		0.307				
		Gy	Typ	0.613				
	BLUE	Bx	-0.03	0.155				
		By		0.055				
Viewing Angle	2D (CR>10)	right( $\phi=0^{\circ}$ )	$\theta_r$ (x axis)	89	-	-	degree	7
		left ( $\phi=180^{\circ}$ )	$\theta_l$ (x axis)	89	-	-		
		up ( $\phi=90^{\circ}$ )	$\theta_u$ (y axis)	89	-	-		
		down ( $\phi=270^{\circ}$ )	$\theta_d$ (y axis)	89	-	-		
	3D (CT≤10%)	up + down	$\theta_u$ (y axis) + $\theta_d$ (y axis)	TBD	20	-		
		up	$\theta_u$ (y axis)	TBD				
down	$\theta_d$ (y axis)	TBD						
3D Crosstalk	3D C/T		1	3	%	8		
Gray Scale			2.2			9		

Ver.1.0

19 / 43

## Product Specification

Notes :1. Contrast Ratio(CR) is defined mathematically as :

$$CR = \frac{\text{Surface Luminance at all white pixels}}{\text{Surface Luminance at all black pixels}}$$

It is measured at center 1-point.

2. Surface luminance is determined after the unit has been 'ON' and 1Hour after lighting the backlight in a dark environment at  $25 \pm 2^\circ\text{C}$ . Surface luminance is the luminance value at center 1-point across the LCD surface 50cm from the surface with all pixels displaying white. For more information see the FIG. 2.
3. The variation in surface luminance,  $\delta$  WHITE is defined as :  

$$\delta \text{ WHITE}(5P) = \text{Maximum}(L_{on1}, L_{on2}, L_{on3}, L_{on4}, L_{on5}) / \text{Minimum}(L_{on1}, L_{on2}, L_{on3}, L_{on4}, L_{on5})$$
 Where  $L_{on1}$  to  $L_{on5}$  are the luminance with all pixels displaying white at 5 locations . For more information, see the FIG. 2.
4. Response time is the time required for the display to transit from G(N) to G(M) (Rise Time,  $Tr_R$ ) and from G(M) to G(N) (Decay Time,  $Tr_D$ ). For additional information see the FIG. 3. (N<M)  
 ※ G to G Spec stands for average value of all measured points.  
 Photo Detector : RD-80S / Field :  $2^\circ$
5. MPRT is defined as 10% to 90% blur-edge width  $B_{ij}$ (pixels) and scroll speed  $U$ (pixels/frame)at the moving picture. For more information, see FIG 4
6. Gray to Gray and MPRT Response time uniformity is Reference data. Appendix VII-1/VII-2
7. Viewing angle is the angle at which the contrast ratio is greater than 10. The angles are determined for the horizontal or x axis and the vertical or y axis with respect to the z axis which is normal to the LCD module surface. For more information, see the FIG. 5.
8. 3D performance specification is expressed by 3D luminance, 3D Crosstalk and 3D viewing angle. 3D luminance and 3D crosstalk is measured at center 1-point. For more information, see the FIG 6~9.
9. Gray scale specification  
 Gamma Value is approximately 2.2. For more information, see the Table 12.

**Table 11. GRAY SCALE SPECIFICATION**

Gray Level	Luminance [%] (Typ.)
L0	0.07
L63	0.27
L127	1.04
L191	2.49
L255	4.68
L319	7.66
L383	11.5
L447	16.1
L511	21.6
L575	28.1
L639	35.4
L703	43.7
L767	53.0
L831	63.2
L895	74.5
L959	86.7
L1023	100

LC320EUD

## Product Specification

Measuring point for surface luminance &amp; measuring point for luminance variation

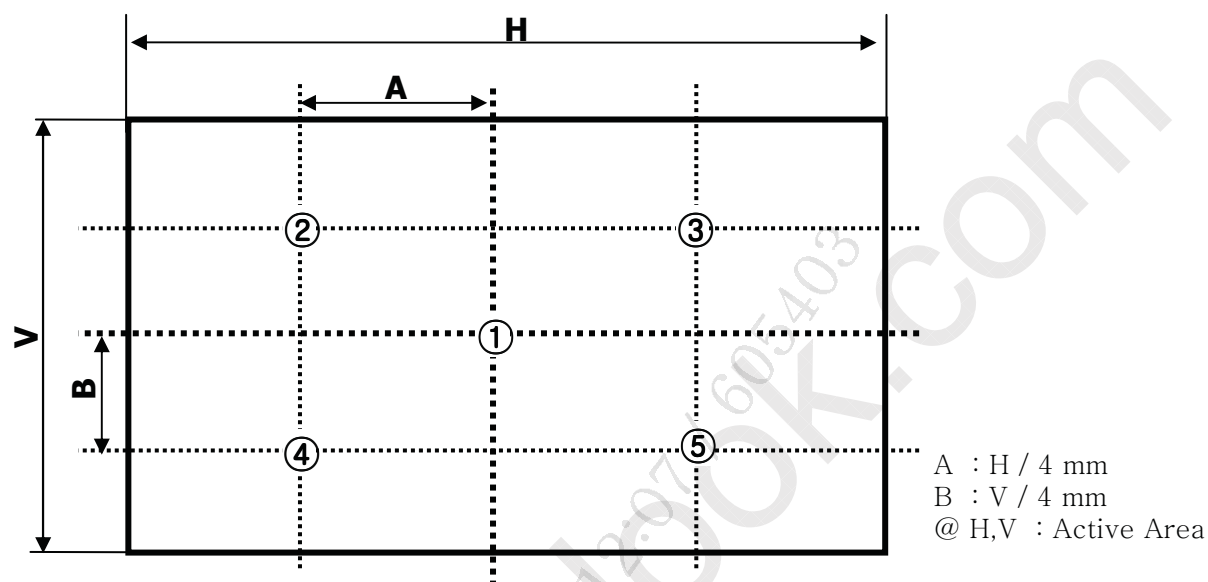

FIG. 2 Measure Point for Luminance

Response time is defined as the following figure and shall be measured by switching the input signal for "Gray(N)" and "Gray(M)".

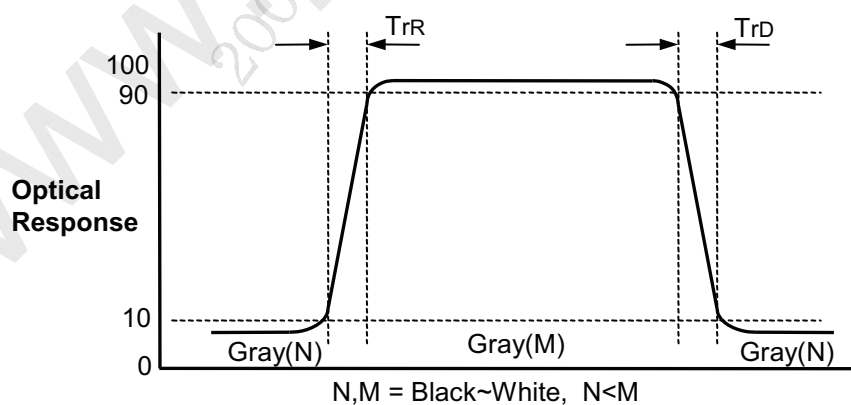

FIG.3 Response Time(G to G)

LC320EUD

## Product Specification

MPRT is defined as 10% to 90% blur-edge with  $B_{ij}$ (pixels) and scroll speed  $U$ (pixels/frame)at the moving picture.

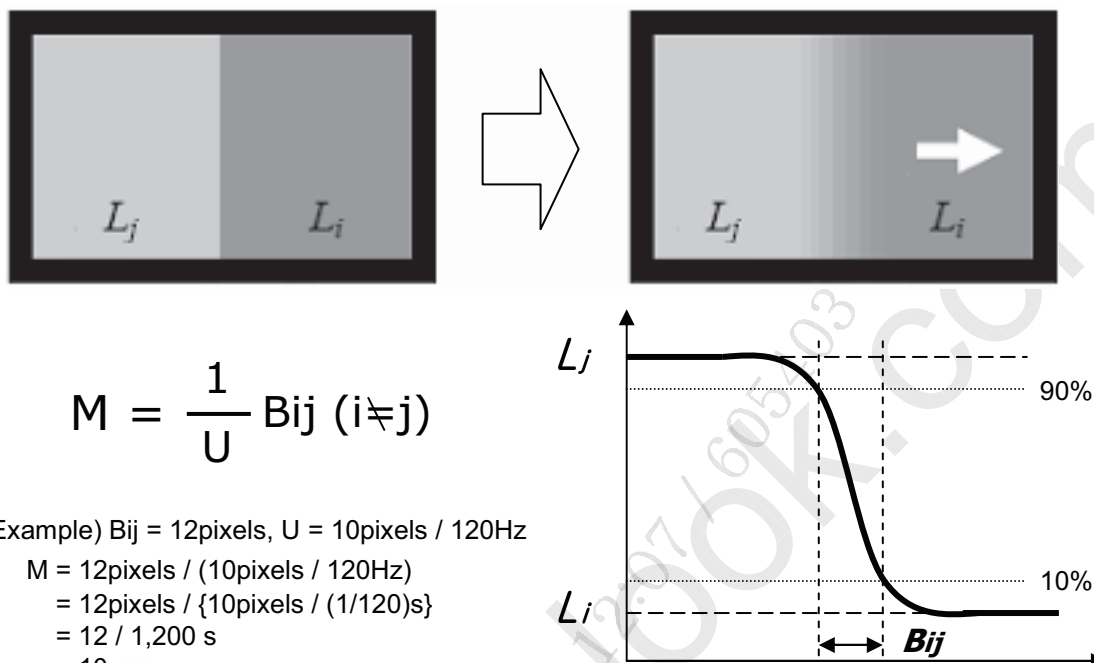

FIG. 4 MPRT

Dimension of viewing angle range

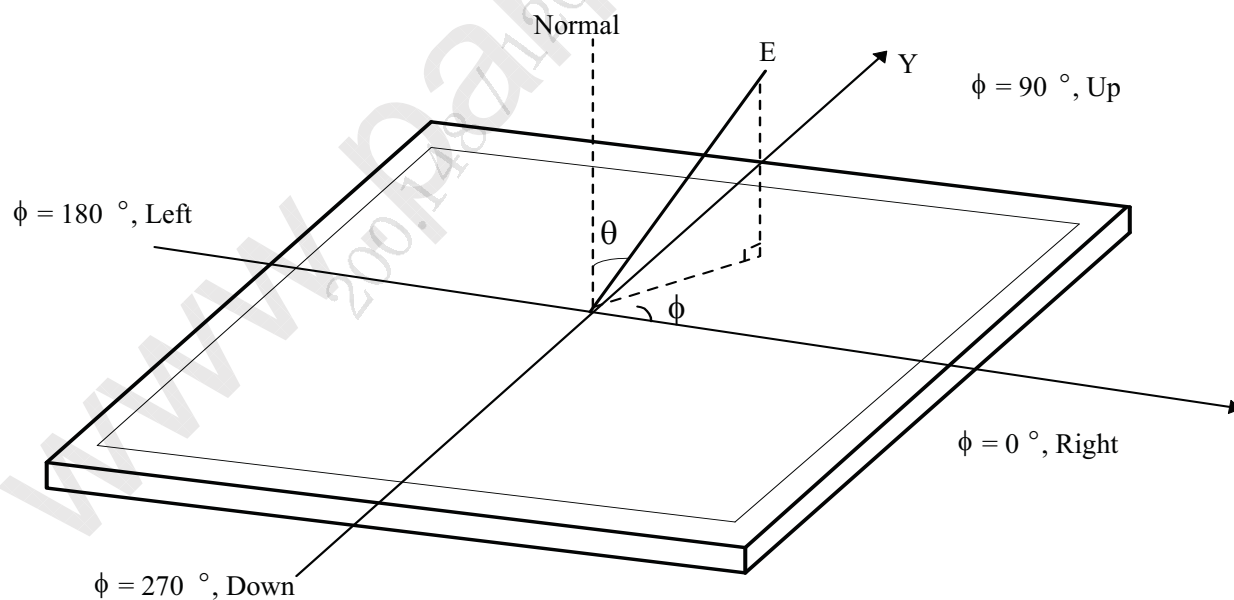
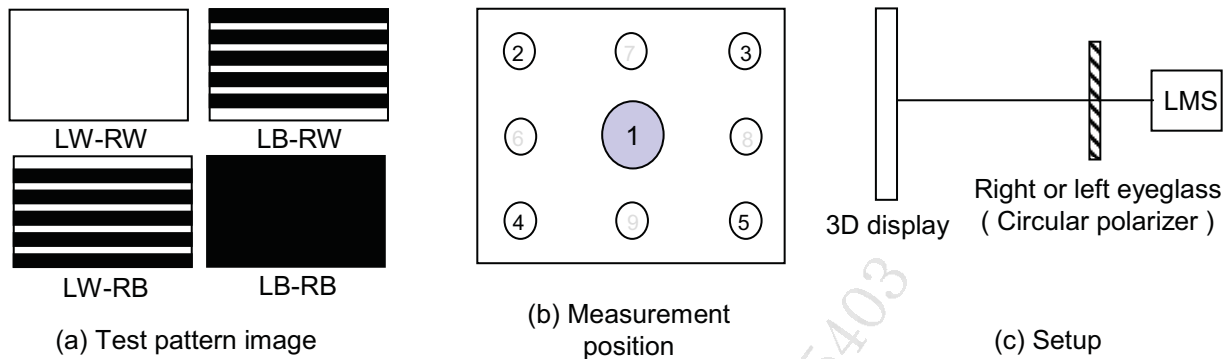
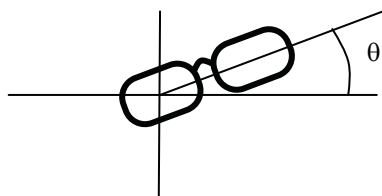

FIG. 5 Viewing angle

## Product Specification



&lt; Figure 6. Measurement configuration &gt;



&lt; Figure 7. Positioning eyeglass &gt;

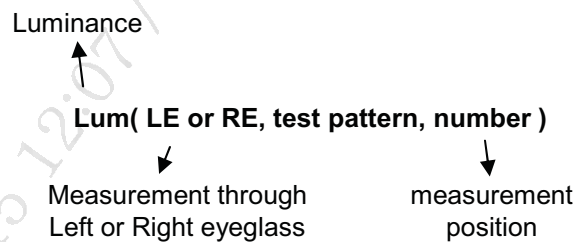

&lt; Figure 8. notation of luminance measurement &gt;

In order to measure 3D luminance, 3D crosstalk and 3D viewing angle, it need to be prepared as below;

## 1) Measurement configuration

4-Test pattern images. Refer to FIG 8.

- LW-RW : White for left and right eye
- LW-RB : White for left eye and Black for right eye
- LB-RW : Black for left eye and white for right eye
- LB-RB : Black for left eye and right eye

Image files where black and white lines are displayed on even or odd lines.

Luminance measurement system (LMS) with narrow FOV (field of view) is used. Refer to FIG 1.

## 2) Positioning Eyeglass

Find angle of minimum transmittance.

This value would be provided beforehand or measured by the following steps;

- (i) Test image (LB-RW) is displayed.
- (ii) Left eyeglass are placed in front of LMS and luminance is measured, rotating right eyeglass such as FIG 7. The notation for luminance measurement is "Lum(LE, LB-RW, 1)".
- (iii) Find the angle where luminance is minimum.

\* Following measurements should be performed at the angle of minimum transmittance of eyeglass.

## Product Specification

## 3) Measurement of 3D luminance

- (i) Test image ( LW-RW ) is displayed.
- (ii) Left or right eyeglass are placed in front of LMS successively and luminance is measured at center 1 point where the notation for luminance measurement is "Lum(LE, LW-RW,1)" or "Lum(RE, LW-RW,1)".

## 4) Measurement of 3D crosstalk

- (i) Test image ( LB-RW, LW-RB and LB-RB ) is displayed.
- (ii) Right or left eyeglass are placed in front of LMS successively and luminance is measured for position 1. with rotating LMS or sample vertically.

Average of

$$\frac{\text{Lum(LE, LB-RW,1)} - \text{Lum(LE, LB-RB,1)}}{\text{Lum(LE, LW-RB,1)} - \text{Lum(LE, LB-RB,1)}}$$

and

$$\frac{\text{Lum(RE, LW-RB,1)} - \text{Lum(RE, LB-RB,1)}}{\text{Lum(RE, LB-RW,1)} - \text{Lum(RE, LB-RB,1)}}$$

## 5) Measurement of 3D Viewing Angle

3D viewing angle is the angle at which the 3D crosstalk is under 10%. The angles are determined for the vertical or y axis with respect to the z axis which is normal to the LCD module surface and measured for position 1. For more information , see the Fig 9

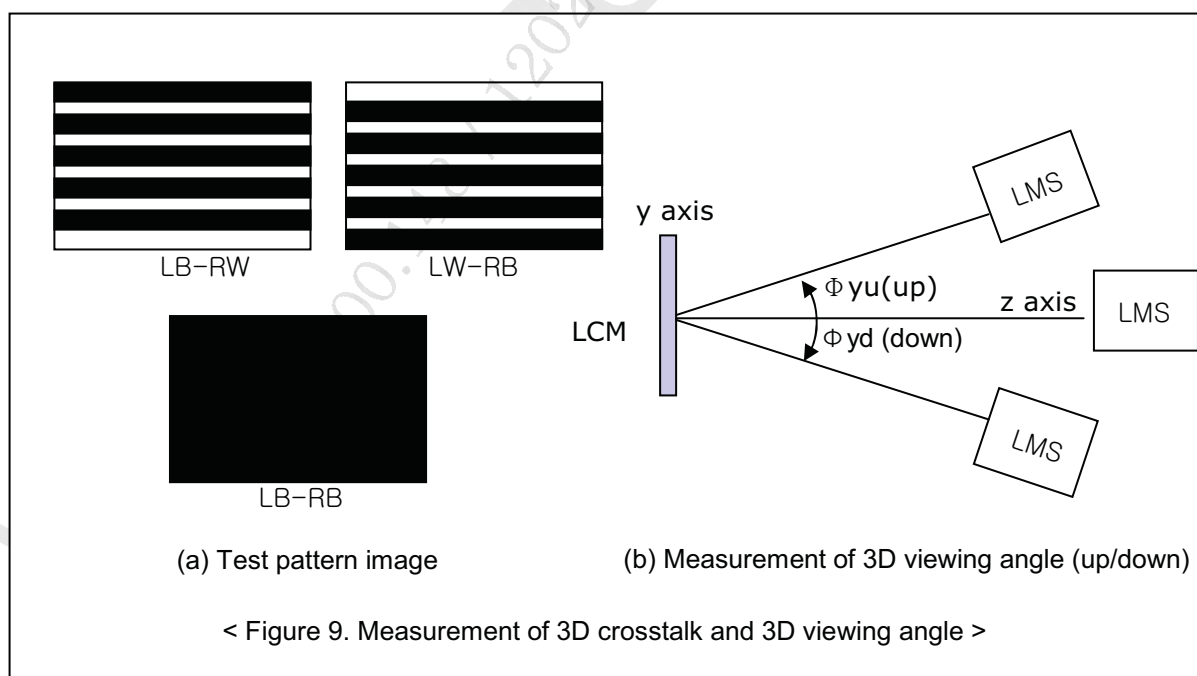



LC320EUD

## Product Specification

**5. Mechanical Characteristics**

Table 12 provides general mechanical characteristics.

**Table 12. MECHANICAL CHARACTERISTICS**

Item	Value	
Outline Dimension	Horizontal	735.4 mm
	Vertical	433 mm
	Depth	10.8 mm (B) / 24.0mm (D)
Bezel Area	Horizontal	705.4 mm
	Vertical	400.0 mm
Active Display Area	Horizontal	698.4 mm
	Vertical	392.85 mm
Weight	4.8kg(Typ), 5.1kg(Max)	

Note : Please refer to a mechanical drawing in terms of tolerance at the next page.

LC320EUD

## Product Specification

## &lt;FRONT VIEW&gt;

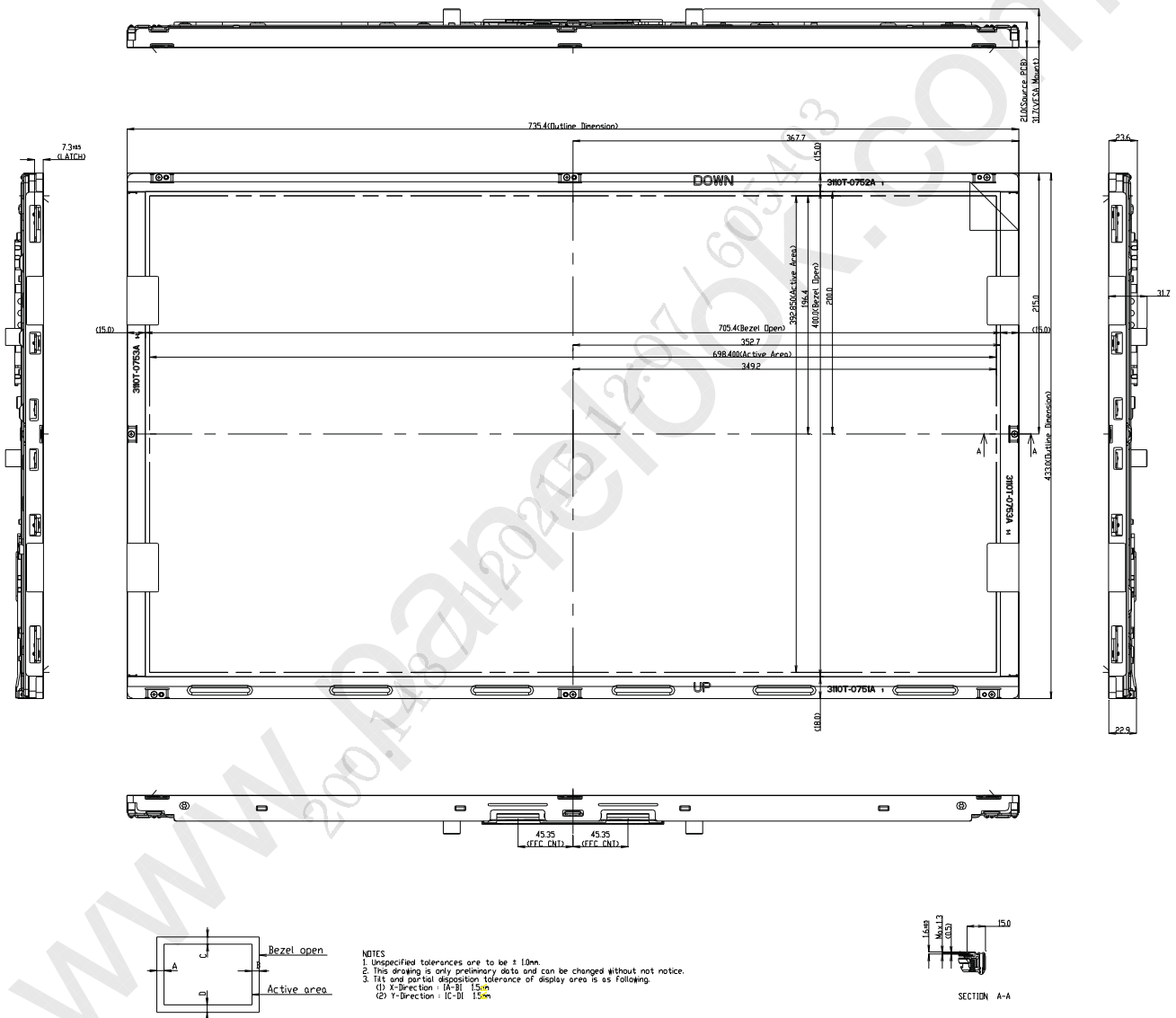

Ver.1.0

26 / 43

LC320EUD

Product Specification

<REAR VIEW>

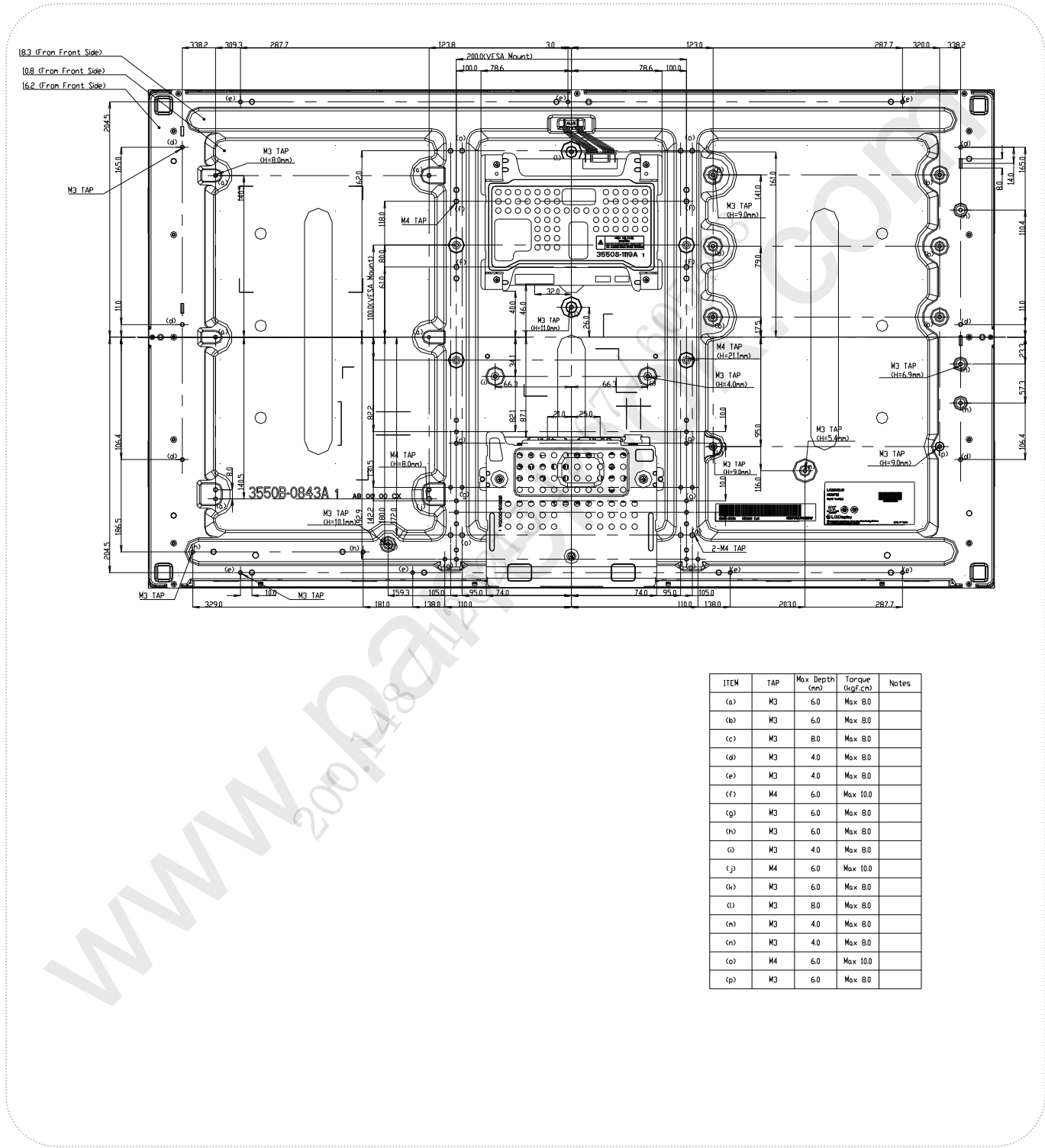

ITEM	TAP	Max Depth (mm)	Torque (kgf.cm)	Notes
(a)	M3	6.0	Max 80	
(b)	M3	6.0	Max 80	
(c)	M3	8.0	Max 80	
(d)	M3	4.0	Max 80	
(e)	M3	4.0	Max 80	
(f)	M4	6.0	Max 100	
(g)	M3	6.0	Max 80	
(h)	M3	6.0	Max 80	
(i)	M3	4.0	Max 80	
(j)	M4	6.0	Max 100	
(k)	M3	6.0	Max 80	
(l)	M3	8.0	Max 80	
(m)	M3	4.0	Max 80	
(n)	M3	4.0	Max 80	
(o)	M4	6.0	Max 100	
(p)	M3	6.0	Max 80	

LC320EUD

## Product Specification

**6. Reliability****Table 13. ENVIRONMENT TEST CONDITION**

No.	Test Item	Condition
1	High temperature storage test	Ta= 60°C 240h
2	Low temperature storage test	Ta= -20°C 240h
3	High temperature operation test	Ta= 50°C 50%RH 240h
4	Low temperature operation test	Ta= 0°C 240h
5	Vibration test (non-operating)	Wave form : random Vibration level : 1.0Grms Bandwidth : 10-300Hz Duration : X,Y,Z, Each direction per 10 min
6	Shock test (non-operating)	Shock level : 50Grms Waveform : half sine wave, 11ms Direction : ±X, ±Y, ±Z One time each direction
7	Humidity condition Operation	Ta= 40 °C ,90%RH
8	Altitude operating storage / shipment	0 - 15,000 ft 0 - 40,000 ft

Note : Before and after Reliability test, LCM should be operated with normal function.

## Product Specification

## 7. International Standards

### 7-1. Safety

- a) UL 60065, Seventh Edition, Underwriters Laboratories Inc.  
Audio, Video and Similar Electronic Apparatus - Safety Requirements.
- b) CAN/CSA C22.2 No.60065:03, Canadian Standards Association.  
Audio, Video and Similar Electronic Apparatus - Safety Requirements.
- c) EN 60065:2002 + A11:2008, European Committee for Electrotechnical Standardization (CENELEC).  
Audio, Video and Similar Electronic Apparatus - Safety Requirements.
- d) IEC 60065:2005 + A1:2005, The International Electrotechnical Commission (IEC).  
Audio, Video and Similar Electronic Apparatus - Safety Requirements.  
(Including report of IEC60825-1:2001 clause 8 and clause 9)

#### Notes

##### 1. Laser (LED Backlight) Information

Class 1M LED Product IEC60825-1 : 2001 Embedded LED Power (Class1M)
---

##### 2. Caution

- : LED inside.
- Class 1M laser (LEDs) radiation when open.
- Do not open while operating.

### 7-2. EMC

- a) ANSI C63.4 "American National Standard for Methods of Measurement of Radio-Noise Emissions from Low-Voltage Electrical and Electronic Equipment in the Range of 9 kHz to 40 GHz." American National Standards Institute (ANSI), 2003.
- b) CISPR 22 "Information technology equipment – Radio disturbance characteristics – Limit and methods of measurement." International Special Committee on Radio Interference (CISPR), 2005.
- c) CISPR 13 "Sound and television broadcast receivers and associated equipment – Radio disturbance characteristics – Limits and method of measurement." International Special Committee on Radio Interference (CISPR), 2006.

### 7-3. Environment

- a) RoHS, Directive 2002/95/EC of the European Parliament and of the council of 27 January 2003

LC320EUD

## Product Specification

**8. Packing****8-1. Information of LCM Label**

a) Lot Mark

A	B	C	D	E	F	G	H	I	J	K	L	M
---	---	---	---	---	---	---	---	---	---	---	---	---

A,B,C : SIZE(INCH)  
E : MONTH

D : YEAR  
F ~ M : SERIAL NO.

Note

## 1. YEAR

Year	2010	2011	2012	2013	2014	2015	2016	2017	2018	2019
Mark	0	1	2	3	4	5	6	7	8	9

## 2. MONTH

Month	Jan	Feb	Mar	Apr	May	Jun	Jul	Aug	Sep	Oct	Nov	Dec
Mark	1	2	4	4	5	6	7	8	9	A	B	C

b) Location of Lot Mark

Serial NO. is printed on the label. The label is attached to the backside of the LCD module.  
This is subject to change without prior notice.

**8-2. Packing Form**

a) Package quantity in one Pallet : 36 pcs

b) Pallet Size : 1140 mm(L) X 870 mm(W) X 117.5 mm(H)

## Product Specification

## 9. Precautions

Please pay attention to the followings when you use this TFT LCD module.

### 9-1. Mounting Precautions

- (1) You must mount a module using specified mounting holes (Details refer to the drawings).
- (2) You should consider the mounting structure so that uneven force (ex. Twisted stress) is not applied to the module. And the case on which a module is mounted should have sufficient strength so that external force is not transmitted directly to the module.
- (3) Please attach the surface transparent protective plate to the surface in order to protect the polarizer. Transparent protective plate should have sufficient strength in order to resist external force.
- (4) You should adopt radiation structure to satisfy the temperature specification.
- (5) Acetic acid type and chlorine type materials for the cover case are not desirable because the former generates corrosive gas of attacking the polarizer at high temperature and the latter causes circuit break by electro-chemical reaction.
- (6) Do not touch, push or rub the exposed polarizers with glass, tweezers or anything harder than HB pencil lead. And please do not rub with dust clothes with chemical treatment. Do not touch the surface of polarizer for bare hand or greasy cloth. (Some cosmetics are detrimental to the polarizer.)
- (7) When the surface becomes dusty, please wipe gently with absorbent cotton or other soft materials like chamois soaks with petroleum benzene. Normal-hexane is recommended for cleaning the adhesives used to attach front / rear polarizers. Do not use acetone, toluene and alcohol because they cause chemical damage to the polarizer
- (8) Wipe off saliva or water drops as soon as possible. Their long time contact with polarizer causes deformations and color fading.
- (9) Do not open the case because inside circuits do not have sufficient strength.

### 9-2. Operating Precautions

- (1) The spike noise causes the mis-operation of circuits. It should be lower than following voltage :  
 $V = \pm 200\text{mV}$  (Over and under shoot voltage)
- (2) Response time depends on the temperature. (In lower temperature, it becomes longer.)
- (3) Brightness depends on the temperature. (In lower temperature, it becomes lower.)  
And in lower temperature, response time (required time that brightness is stable after turned on) becomes longer
- (4) Be careful for condensation at sudden temperature change. Condensation makes damage to polarizer or electrical contacted parts. And after fading condensation, smear or spot will occur.
- (5) When fixed patterns are displayed for a long time, remnant image is likely to occur.
- (6) Module has high frequency circuits. Sufficient suppression to the electromagnetic interference shall be done by system manufacturers. Grounding and shielding methods may be important to minimize the interference.
- (7) Please do not give any mechanical and/or acoustical impact to LCM. Otherwise, LCM can't be operated its full characteristics perfectly.
- (8) A screw which is fastened up the steels should be a machine screw.  
(if not, it can cause conductive particles and deal LCM a fatal blow)
- (9) Please do not set LCD on its edge.
- (10) The conductive material and signal cables are kept away from LED driver inductor to prevent abnormal display, sound noise and temperature rising.

## Product Specification

### 9-3. Electrostatic Discharge Control

Since a module is composed of electronic circuits, it is not strong to electrostatic discharge. Make certain that treatment persons are connected to ground through wrist band etc. And don't touch interface pin directly.

### 9-4. Precautions for Strong Light Exposure

Strong light exposure causes degradation of polarizer and color filter.

### 9-5. Storage

When storing modules as spares for a long time, the following precautions are necessary.

- (1) Store them in a dark place. Do not expose the module to sunlight or fluorescent light. Keep the temperature between 5°C and 35°C at normal humidity.
- (2) The polarizer surface should not come in contact with any other object.  
It is recommended that they be stored in the container in which they were shipped.
- (3) Storage condition is guaranteed under packing conditions.
- (4) The phase transition of Liquid Crystal could be recovered if the LCM is released at the normal condition after the low or over the storage temperature.

### 9-6. Handling Precautions for Protection Film

- (1) The protection film is attached to the bezel with a small masking tape.  
When the protection film is peeled off, static electricity is generated between the film and polarizer.  
This should be peeled off slowly and carefully by people who are electrically grounded and with well ion-blown equipment or in such a condition, etc.
- (2) When the module with protection film attached is stored for a long time, sometimes there remains a very small amount of glue still on the bezel after the protection film is peeled off.
- (3) You can remove the glue easily. When the glue remains on the bezel surface or its vestige is recognized, please wipe them off with absorbent cotton waste or other soft material like chamois soaked with normal-hexane.



LC320EUD

## Product Specification

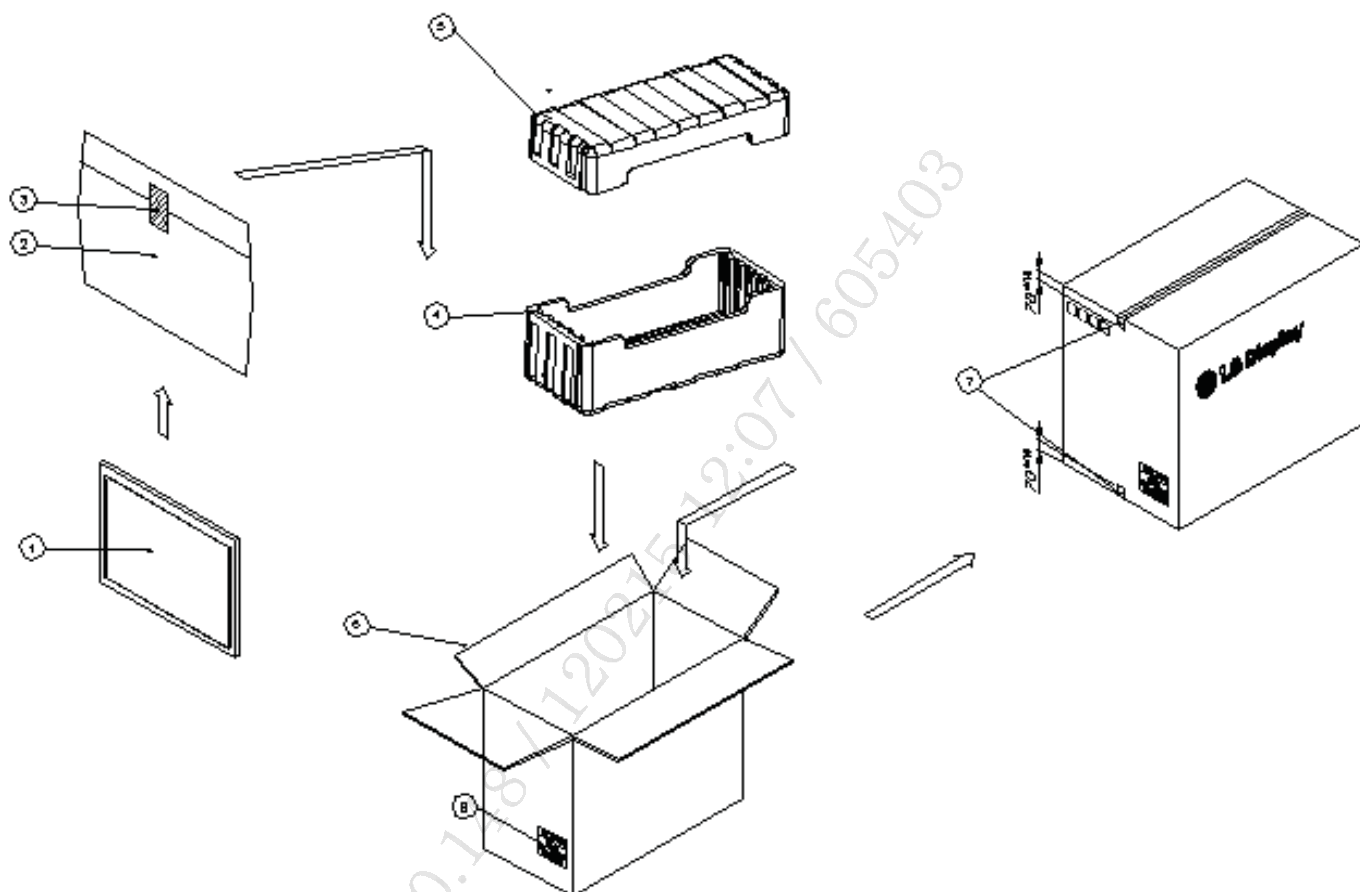
**# APPENDIX-I-1**
**■ Packing Ass'y**

NO.	DESCRIPTION	MATERIAL
1	LCD Module	
2	BAG	AL
3	TAPE	MASKING 20MMX50M
4	Packing,Top	EPS
5	Packing,Bottom	EPS
6	BOX	PAPER_DW3
7	TAPE	OPP 70MMX300M
8	Label	ART 100X70

LC320EUD

## Product Specification

## # APPENDIX-I-2

## ■ Pallet Ass'y

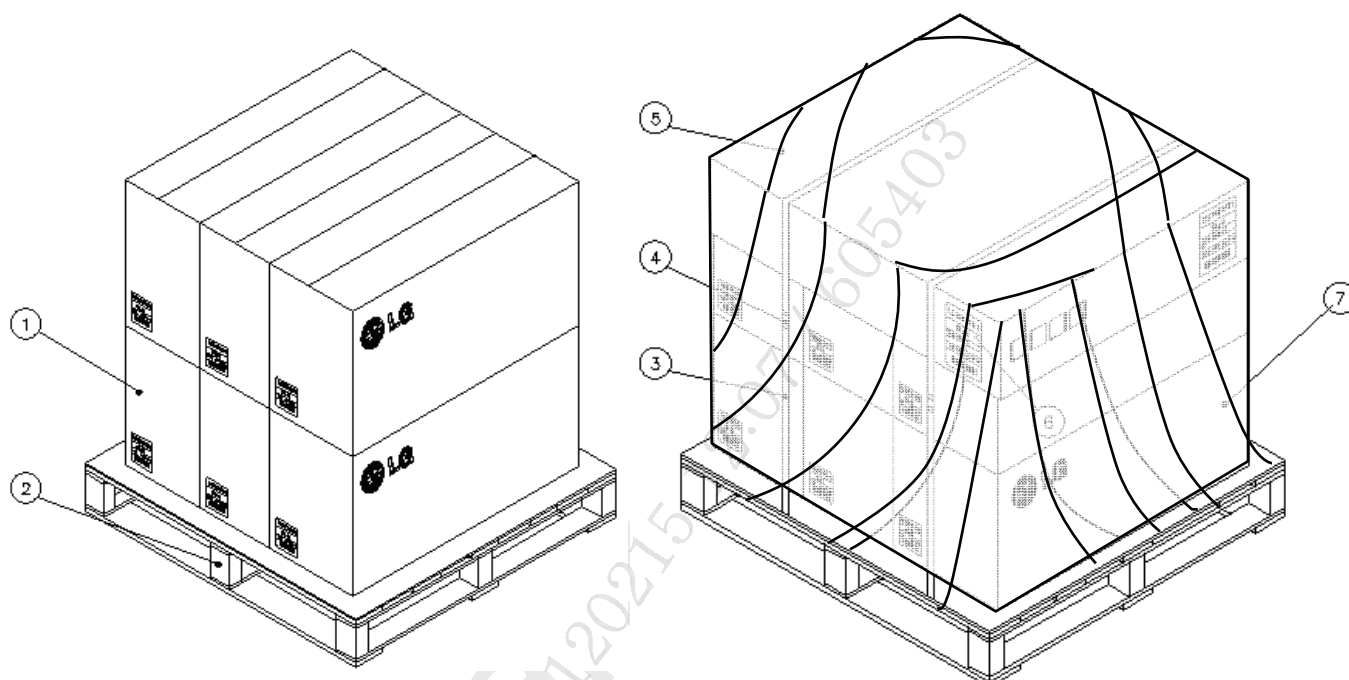

Box quantity per pallet: 6ea

NO.	DESCRIPTION	MATERIAL
1	PACKING ASS'Y	
2	PALLET	Plywood
3	BAND	PP
4	CLIP, BAND	STEEL
5	ANGLE, PACKING	PAPER (SWR4)
6	LABEL	PAPER

LC320EUD

## Product Specification

## # APPENDIX- II-1

## ■ LCM Label

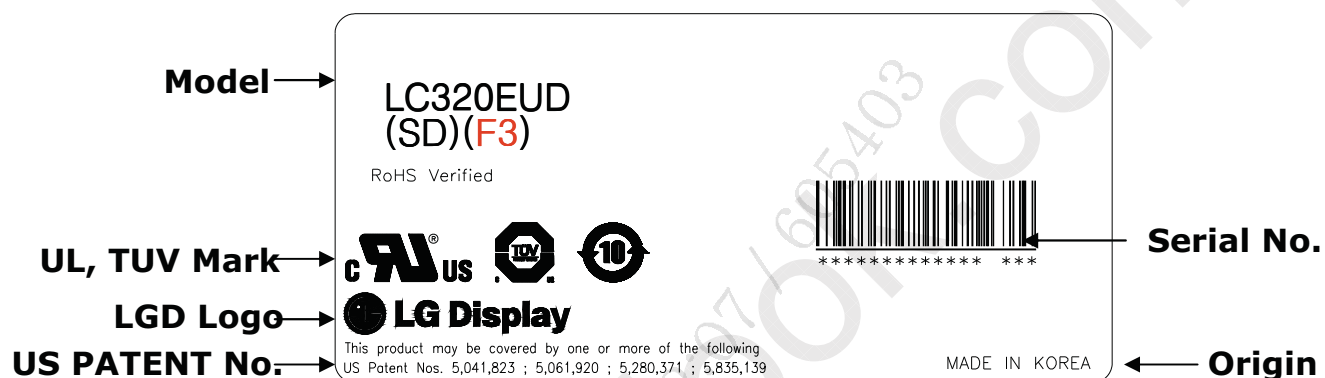

LC320EUD

## Product Specification

## # APPENDIX- II-2

## ■ Pallet Label

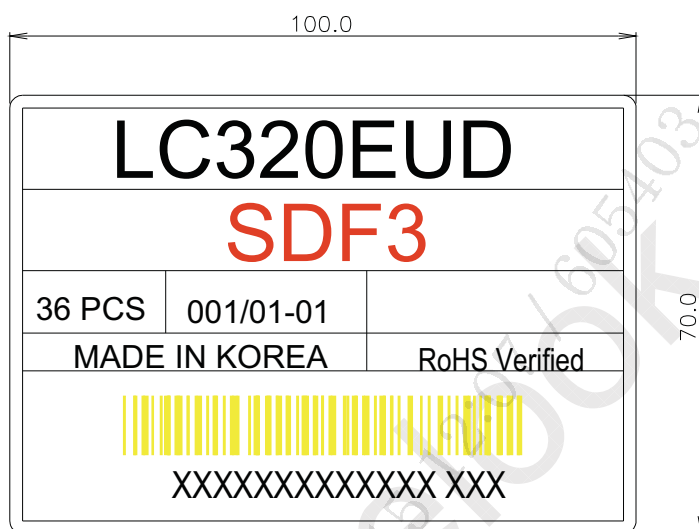

## Product Specification

## # APPENDIX- III-1

■ Required signal assignment for Flat Link (Thine : THC63LVD103) Transmitter(Pin7="L" or "NC")

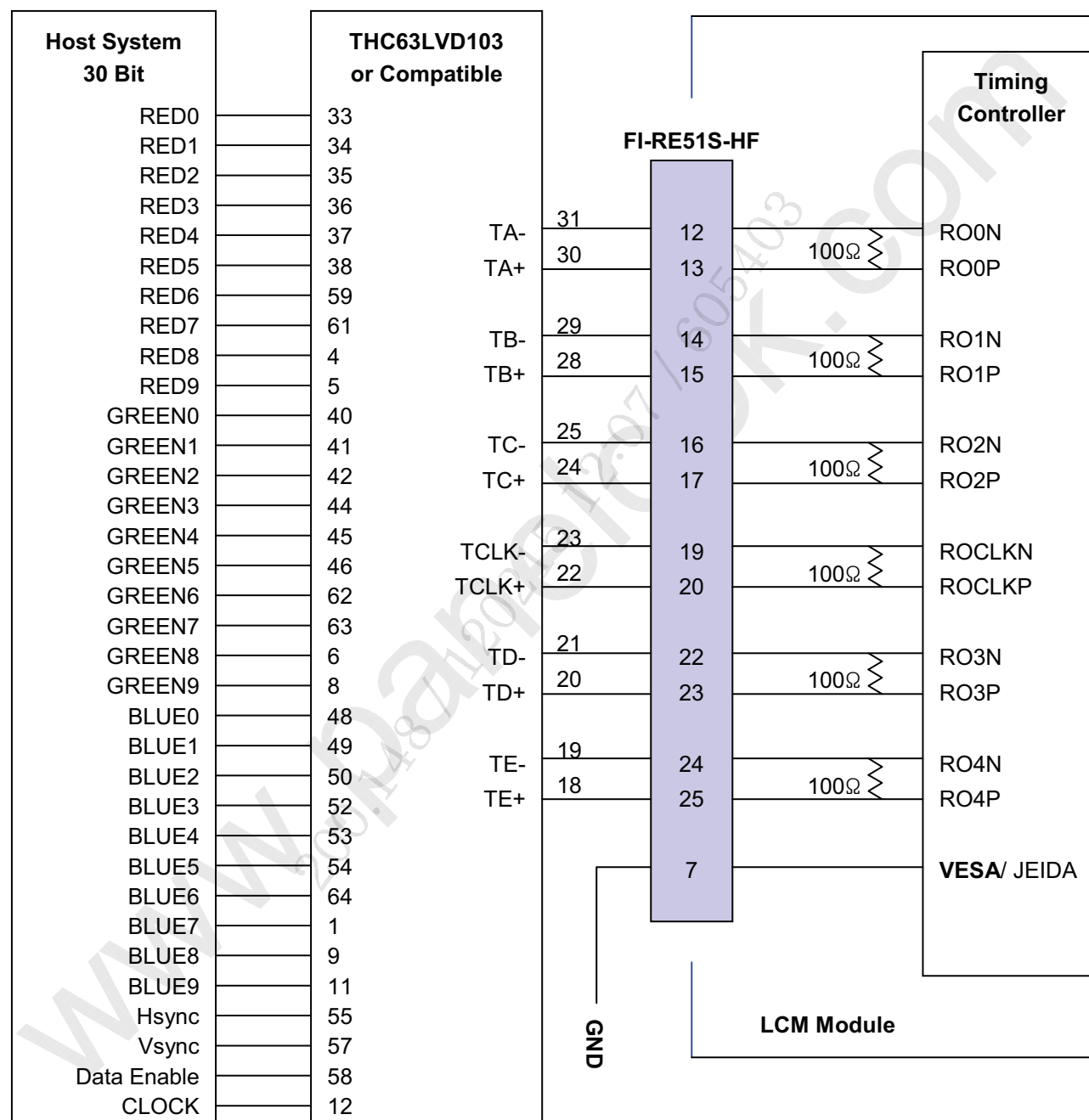

Note: 1. The LCD module uses a 100 Ohm[Ω] resistor between positive and negative lines of each receiver input.

2. Refer to LVDS Transmitter Data Sheet for detail descriptions. (THC63LVD103 or Compatible)

3. '9' means MSB and '0' means LSB at R,G,B pixel data.

## Product Specification

## # APPENDIX- III-2

■ Required signal assignment for Flat Link (Thine : THC63LVD103) Transmitter(Pin7="H")

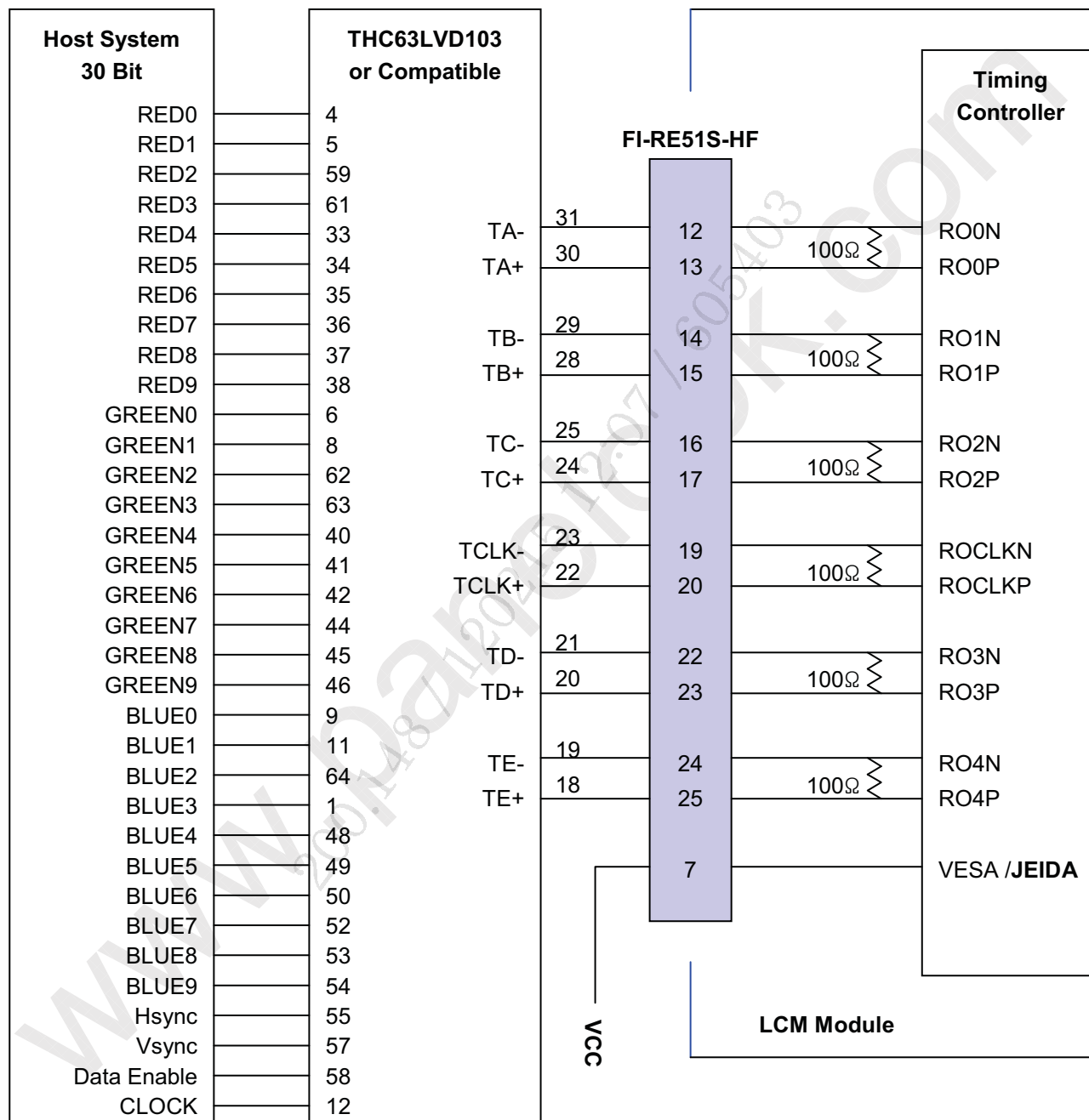

Note :1. The LCD module uses a 100 Ohm[Ω] resistor between positive and negative lines of each receiver input.

2. Refer to LVDS Transmitter Data Sheet for detail descriptions. (THC63LVD103 or Compatible)

3. '9' means MSB and '0' means LSB at R,G,B pixel data.

## Product Specification

## # APPENDIX- IV-1

## ■ LVDS Data-Mapping Information (10 Bit )

## 1) LVDS Select : "H" Data-Mapping (JEIDA format)

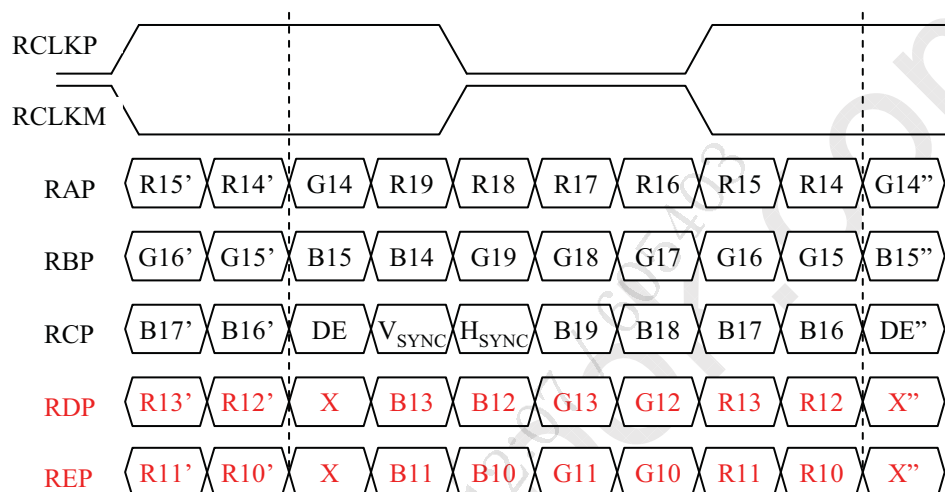

## 2) LVDS Select : "L" Data-Mapping (VESA format)

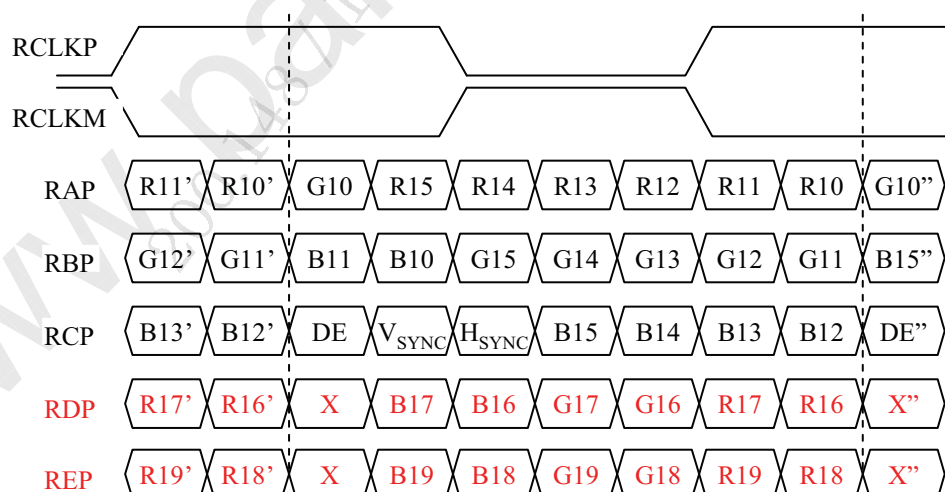

## Product Specification

## # APPENDIX- IV-2

## ■ LVDS Data-Mapping Information (8 Bit )

## 1) LVDS Select : "H" Data-Mapping (JEIDA format)

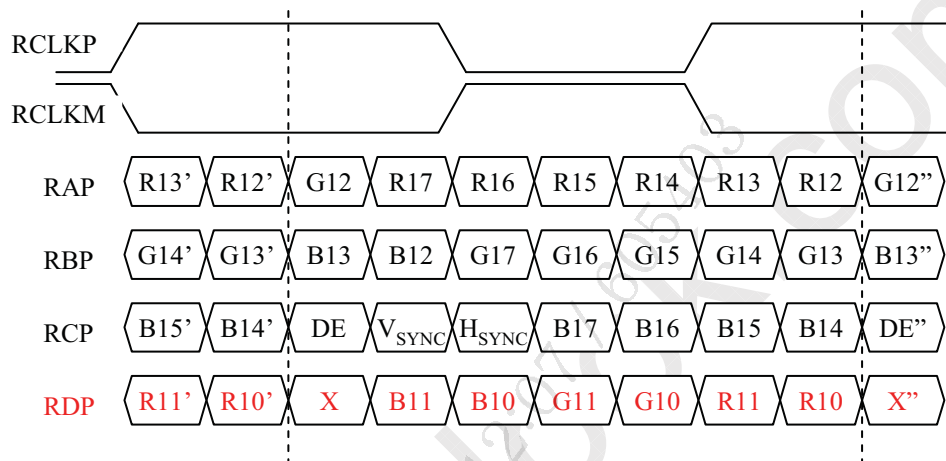

## 2) LVDS Select : "L" Data-Mapping (VESA format)

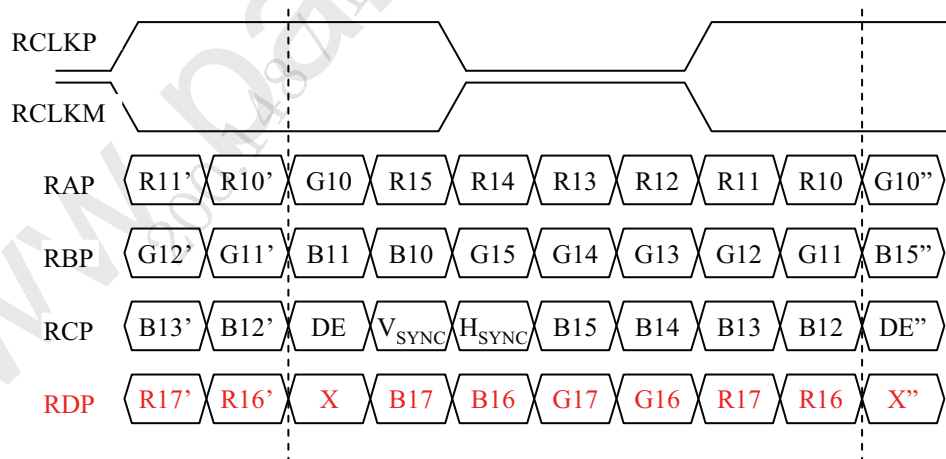



## # APPENDIX- V-1

## ■ Option Pin Circuit Block Diagram

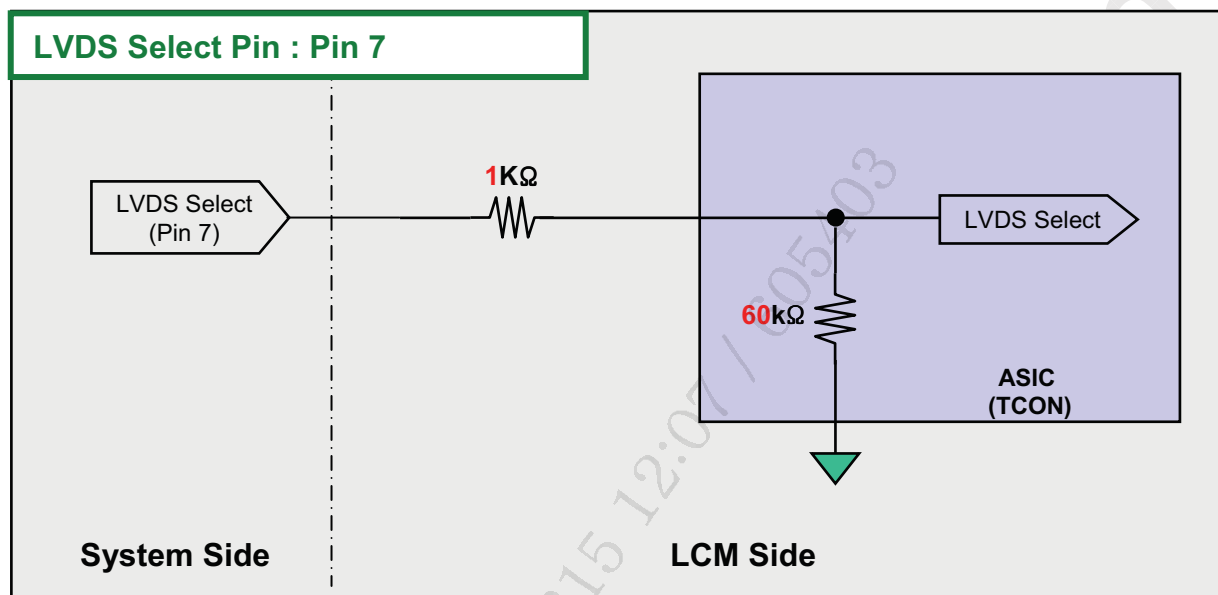
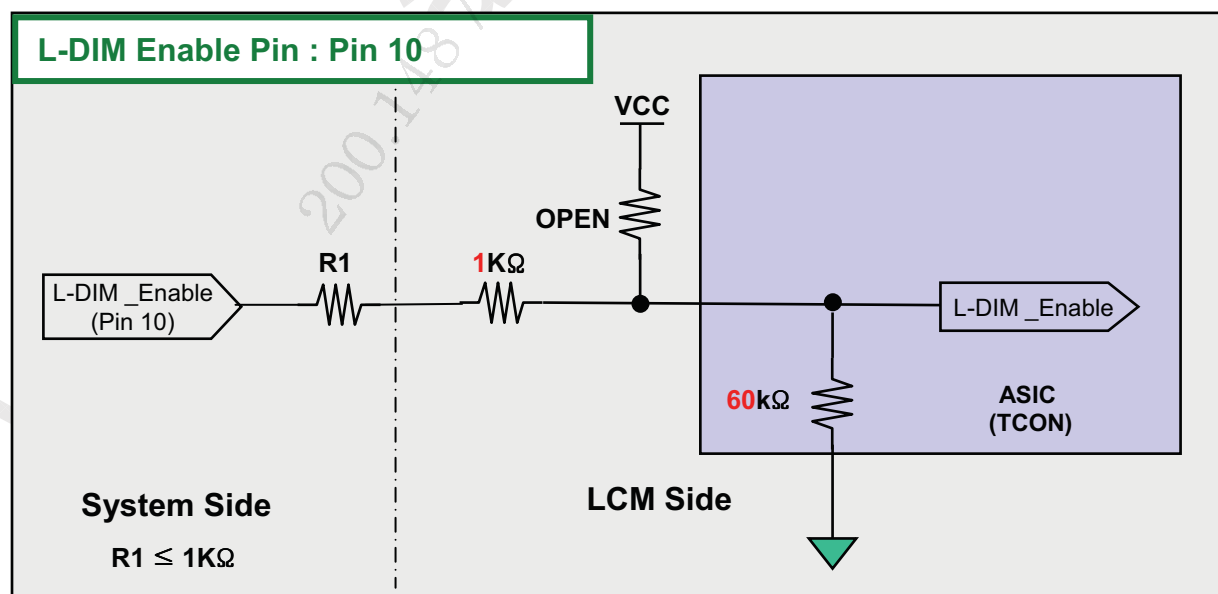
1) Circuit Block Diagram of **LVDS Format** Selection pin2) Circuit Block Diagram of **L-DIM Enable** Selection pin

LC320EUD

## Product Specification

## # APPENDIX- V-2

## ■ Option Pin Circuit Block Diagram

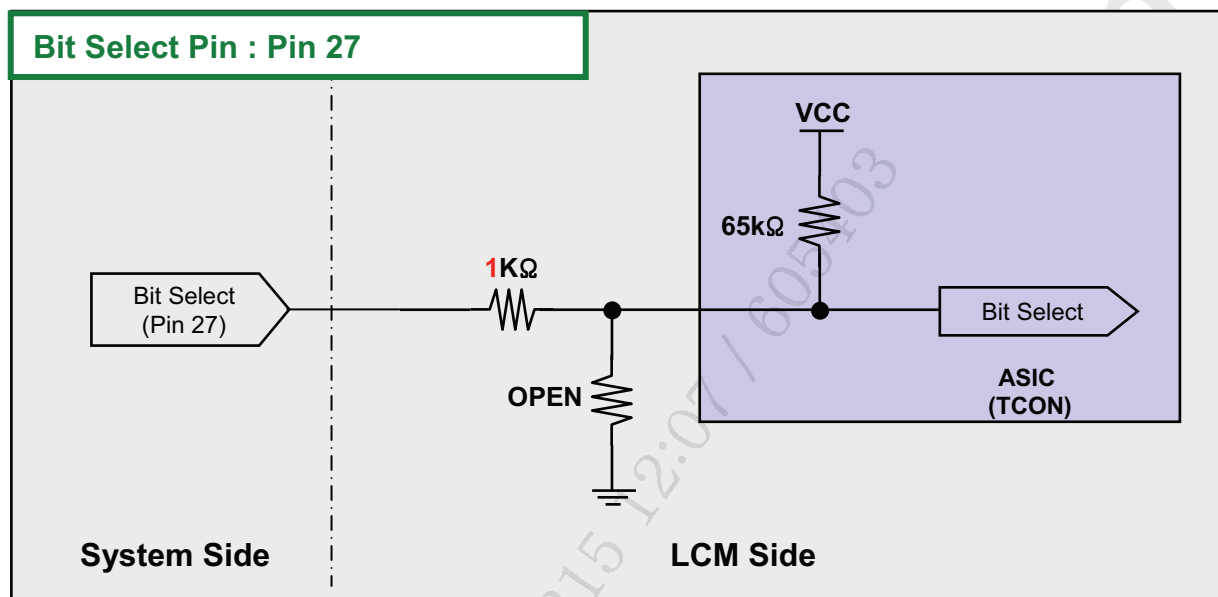
3) Circuit Block Diagram of **Bit** Selection pin

Product Specification

# APPENDIX- VI

■ EXT<sub>BR-B</sub> & Local Dimming Design Guide

- 1) When L-Dim Enable is "L", Vertical Sync Signal = System Dimming with 100Hz or 120Hz frequency.
- 2) Local Dimming signals are synchronized with V-Sync Freq. of System in T-Con Board.
- 3) EXT<sub>BR-B</sub> Specification ( VCC = 3.3V ) @ Local Dimming
  - a) High Voltage Range : 2.5 V ~ 3.6 V
  - b) Low Voltage Range : 0.0 V ~ 0.8 V

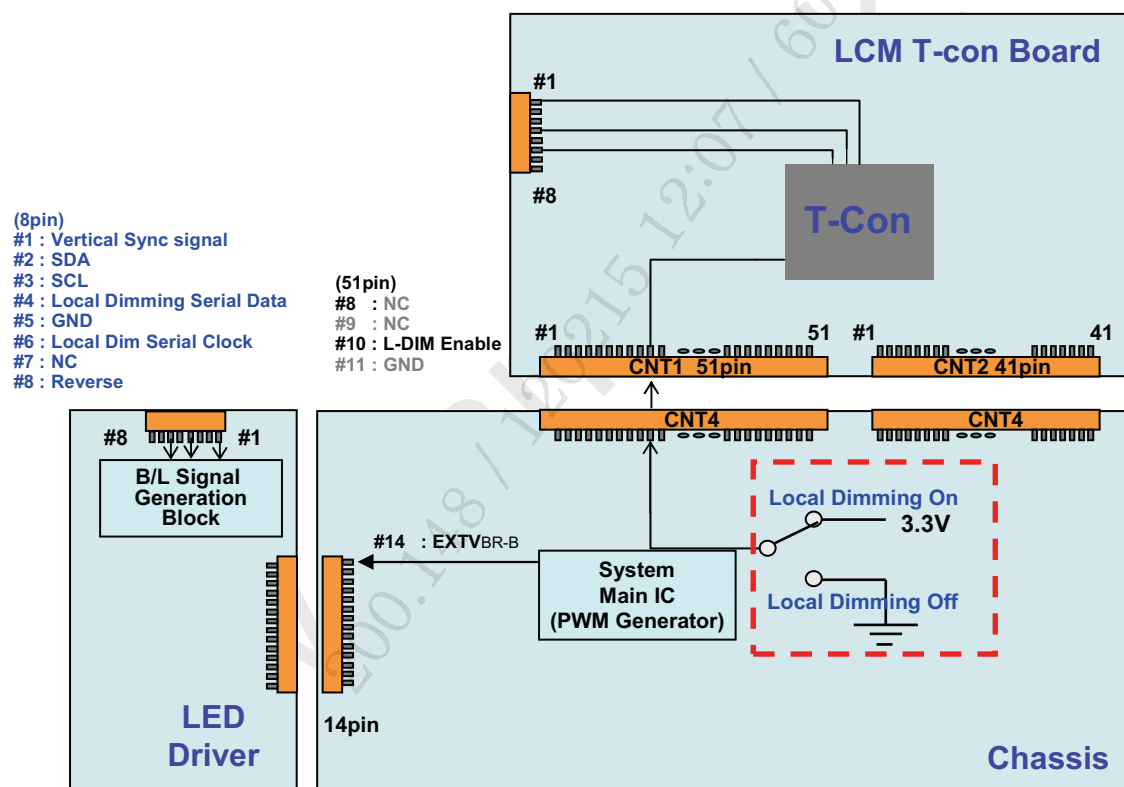

<With Driver Model>

EXT <sub>BR-B</sub> Frequency	Recommendation: 100 Hz for PAL 120 Hz for NTSC
Rising Time	MAX 10.0 μs
Falling Time	MAX 10.0 μs

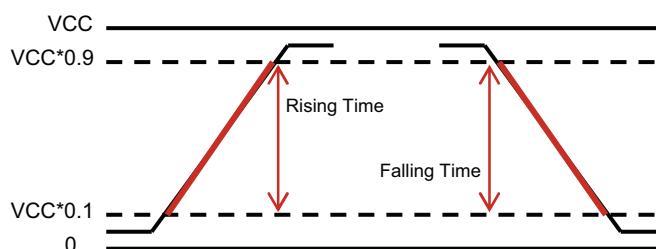

Product Specification

### # APPENDIX- VI-2 Local Dimming Interface Design Guide

- ▶ Data Sequence (※ based on 10 Block )
  - 8-bit : Indicator(1010\_1010) / Command(8-bit) / Data1(8-bit) / Data2(8-bit) / ... / Data10(8-bit) / check\_Sum(8-bit)
  - 10-bit : Indicator(1010\_0000\_00) / Command(10-bit) / Data1(10-bit) / Data2(10-bit) / ... / Data10(10-bit) / check\_Sum(10-bit)
- ▶ Data field Definition (※ based on 10 Block )
  1. Indicator Byte : Start of data sequence
  2. Command Byte
    - Bit 0 : Local-Dimming Enable ( '1' : Enable, '0' : Disable )
    - Bit 1 : Scanning Enable ( '1' : Enable, '0' : Disable )
    - Bit 2~6 : Reserved (Must be Low Level ('0'))
    - Bit 7 : Reverse Enable ( '1' : Enable (Reverse), '0' : Disable (Normal) )
  3. Data Byte 1 ~ 10 : 8 / 10 -bit Local-dimming gray value
  4. Check\_Sum Byte = Indicator ^ Command ^ Data1 ^ Data2 ^ ... Data10 (※ ^ : Exclusive OR)

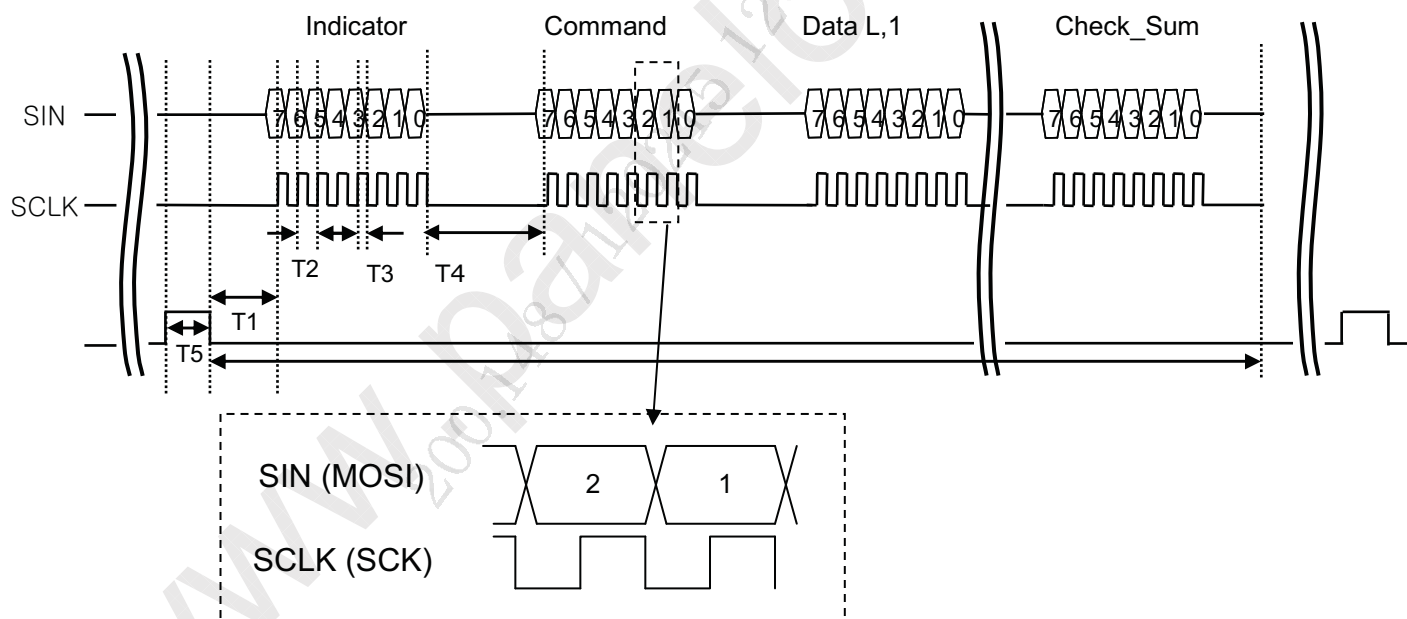

Table15. TIMING TABLE for Local Dimming Interface

※ SPI Clock Range : Min 100 [KHz], Max 500 [KHz]

Parameter (SCLK rising edge기준)	Values			Units
	Min	Typ	Max	
T1	6.00	-	30.00	us
T2	2.00	-	10.00	us
T3	1.00	-	5.00	us
T4	6.00	-	30.00	us
T5	20.00	-	40.00	us

LC320EUD

## Product Specification

## # APPENDIX- VI-2

## ▶ Local Dimming Block Mapping

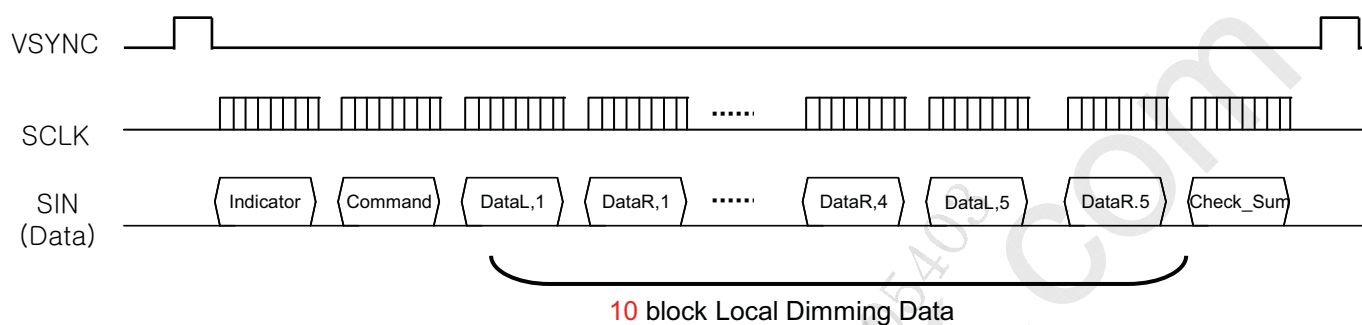

## Front (Non Reverse Mode)

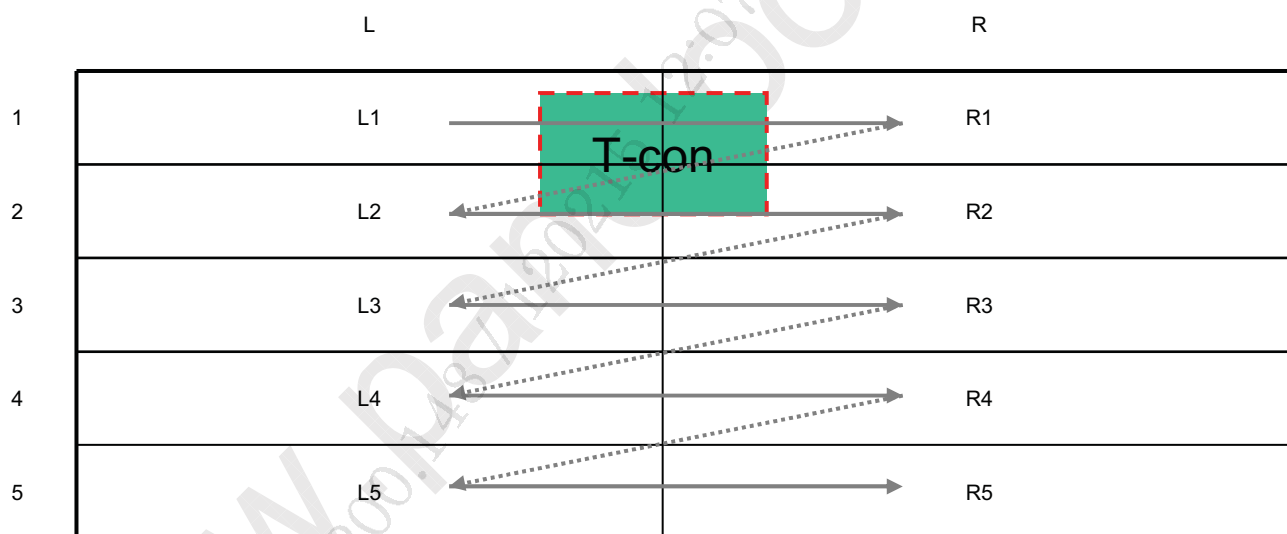

Product Specification

# APPENDIX- VII-1

Gray to Gray Response Time Uniformity

This is only the reference data of G to G and uniformity for LC320EUF-SDF2 model.

1. G to G Response Time :

Response time is defined as Figure3 and shall be measured by switching the input signal for "Gray (N) " and "Gray(M)".(32Gray Step at 8bit)

2. G to G Uniformity

The variation of G to G Uniformity ,  $\delta_{G \text{ to } G}$  is defined as :

$$G \text{ to } G \text{ Uniformity} = \frac{\text{Maximum}(GtoG) - \text{Typical}(GtoG)}{\text{Typical}(GtoG)} \leq 1$$

\*Maximum (GtoG) means maximum value of measured time (N, M = 0 (Black) ~ 1023(White), 128 gray step).

	0Gray	127ray	255Gray	...	895Gray	1023Gray
0Gray		TrR:0G→127G	TrR:0G→255G	...	TrR:0G→895G	TrR:0G→1023G
127Gray	TrD:127G→0G		TrR:127G→255G	...	TrR:127G→895G	TrR:127G→1023G
255Gray	TrD:255G→0G	TrD:255G→127G		...	TrR:255G→895G	TrR:255G→1023G
...	...	...	...	...	...	...
895Gray	TrD:895G→0G	TrD:895G→127G	TrD:895G→255G	...		TrR:895G→1023G
1023Gray	TrD:1023G→0G	TrD:1023G→127G	TrD:1023G→255G	...	TrD:1023G→895G	

3. Sampling Size : 2 pcs

4. Measurement Method : Follow the same rule as optical characteristics measurement.

5. Current Status

Below table is actual data of production on Oct.15. 2010 ( LGD RV Event Sample)

	G to G Response Time [ms]		Uniformity
	Min.	Max.	
# 1	3.54	9.39	5.92
# 2	3.61	9.30	5.98

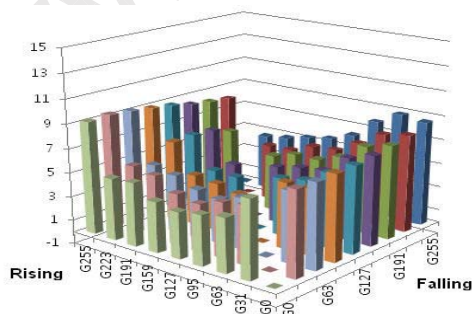

< # 1 >

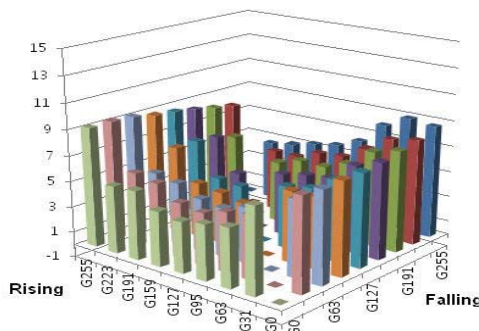

< # 2 >

Product Specification

# APPENDIX- VII-2

■ MPRT Response Time Uniformity ( $\delta_{MPRT}$ )

This is only the reference data of MPRT and uniformity for LC320EUD-SDF2 model.

1. MPRT Response Time :  
Response time is defined as Figure3

2. MPRT Uniformity  
The variation of MPRT Uniformity ,  $\delta_{MPRT}$  is defined as :

$$MPRT \text{ Uniformity} = \frac{\text{Maximum (MPRT)} - \text{Typical (MPRT)}}{\text{Typical (MPRT)}} \leq 1$$

3. Sampling Size : 2 pcs

4. Measurement Method : Follow the same rule as optical characteristics measurement.

5. Current Status

Below table is actual data of production on Oct. 20. 2010 ( LGD RV Event Sample)

Sample	MPRT Response Time [ms]		Uniformity
	Min.	Max.	
# 1	3.06	10.69	6.48
# 2	3.04	10.95	6.76

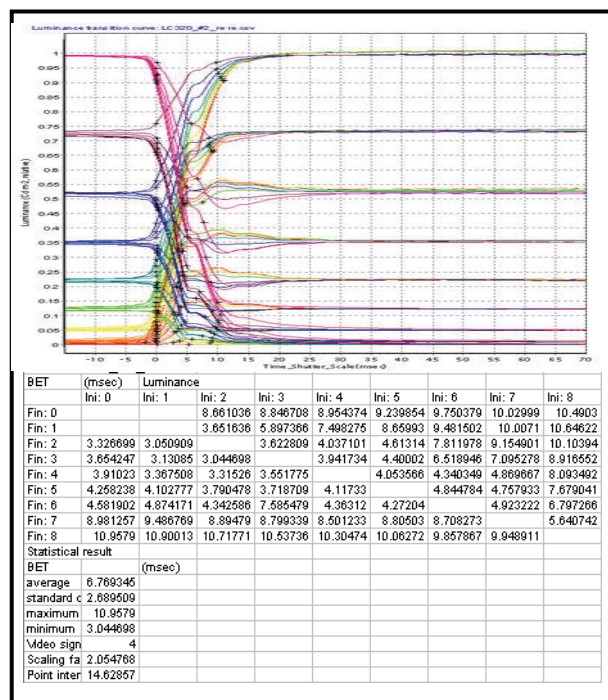
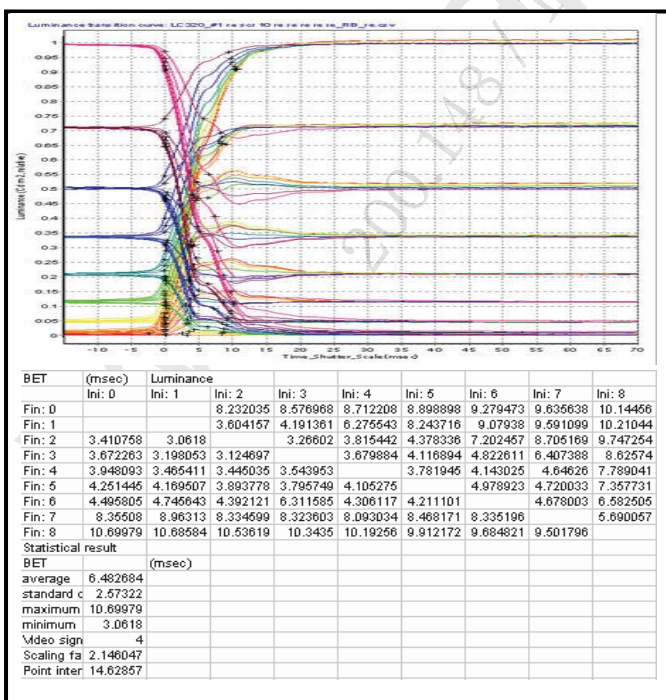

Product Specification

# APPENDIX- VIII

■ Standard specification of Eyeglasses

This is recommended data of Eyeglasses for LC320EUD-SDF2 model. (details refer to table)

For each item, depending on the eyeglass manufacturer tolerances may occur, this tolerance can affect 3D performance. (3D Crosstalk, 3D luminance, 3D viewing angle)

<Table. Standard specification of Eyeglasses>

Design item of Eyeglasses		Left	Right	Remark
Optical axis	a) Slow axis of retarder	135°	45°	Refer to drawing
	b) Transmission axis of polarizer	0°	0°	
Retardation value	Retarder	125nm		@550nm

※ Recommended polarizer  
Polarization efficiency: more than 99.90%

