

## SPECIFICATION FOR APPROVAL

- ( ) Preliminary Specification  
 ( ● ) Final Specification

Title	32.0" WXGA TFT LCD
-------	--------------------

BUYER	SONY
MODEL	

SUPPLIER	LG Display Co., Ltd.
*MODEL	LC320EXN
SUFFIX	SDP1(RoHS Verified)

\*When you obtain standard approval,  
 please use the above model name without suffix

APPROVED BY	SIGNATURE DATE
/	_____
/	_____
/	_____

Please return 1 copy for your confirmation with  
 your signature and comments.

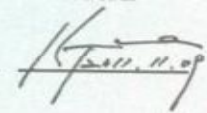
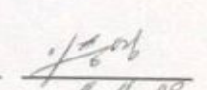
APPROVED BY	SIGNATURE DATE
J.T.Kim / Team Leader	 _____
REVIEWED BY	
S.Y.Lee / Project Leader	 _____
PREPARED BY	
J Y LEE / Engineer	 _____

**TV Product Development Dept.**  
**LG Display Co., Ltd**

## Product Specification

**CONTENTS**

Number	ITEM	Page
	COVER	1
	CONTENTS	2
	RECORD OF REVISIONS	3
1	GENERAL DESCRIPTION	4
2	ABSOLUTE MAXIMUM RATINGS	5
3	ELECTRICAL SPECIFICATIONS	6
3-1	ELECTRICAL CHARACTERISTICS	6
3-2	INTERFACE CONNECTIONS	8
3-3	SIGNAL TIMING SPECIFICATIONS	10
3-4	LVDS SIGNAL SPECIFICATIONS	11
3-5	COLOR DATA REFERENCE	14
3-6	POWER SEQUENCE	15
4	OPTICAL SPECIFICATIONS	17
5	MECHANICAL CHARACTERISTICS	21
6	RELIABILITY	24
7	INTERNATIONAL STANDARDS	25
7-1	SAFETY	25
7-2	EMC	25
7-3	ENVIRONMENT	25
8	PACKING	26
8-1	DESIGNATION OF LOT MARK	26
8-2	PACKING FORM	26
9	PRECAUTIONS	27
9-1	MOUNTING PRECAUTIONS	27
9-2	OPERATING PRECAUTIONS	27
9-3	ELECTROSTATIC DISCHARGE CONTROL	27
9-4	PRECAUTIONS FOR STRONG LIGHT EXPOSURE	27
9-5	STORAGE	27
9-6	HANDLING PRECAUTIONS FOR PROTECTION FILM	27

Product Specification

**RECORD OF REVISIONS**

Revision No.	Revision Date	Page	Description
0.1	Oct. 06. 2011	-	Preliminary Specification (First Draft)
1.0	Nov. 09. 2011	-	Final Specification

## Product Specification

## 1. General Description

The LC320EXN is a Color Active Matrix Liquid Crystal Display with an integral Light Emitting Diode (LED) backlight system. The matrix employs a-Si Thin Film Transistor as the active element. It is a transmissive display type which is operating in the normally black mode. It has a 31.51 inch diagonally measured active display area with WXGA resolution (768 vertical by 1366 horizontal pixel array). Each pixel is divided into Red, Green and Blue sub-pixels or dots which are arranged in Horizontal stripes. Gray scale or the luminance of the sub-pixel color is determined with a 8-bit gray scale signal for each dot, thus presenting a palette of more than 16.7M(6bit + A-FRC) colors.

It has been designed to apply the 8-bit 1-port LVDS interface.

It is intended to support LCD TV, PCTV where high brightness, super wide viewing angle, high color gamut, high color depth and fast response time are important.

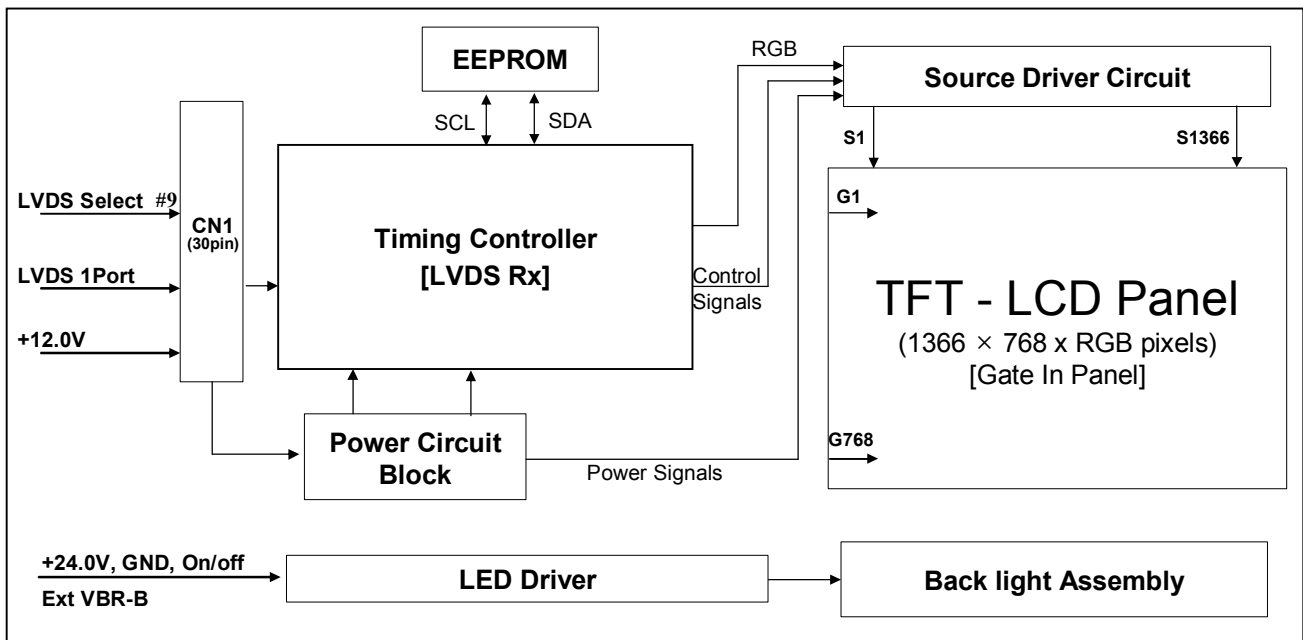

## General Features

Active Screen Size	31.51 inches(800.4mm) diagonal
Outline Dimension	735.4 mm(H) x 433.0 mm(V) x 10.8 mm(D) (Typ.)
Pixel Pitch	170.25 $\mu$ m x 510.75 $\mu$ m x RGB
Pixel Format	1366 horiz. by 768 vert. pixels RGB stripe arrangement
Color Depth	8bit(D), 16,7 M colors
Luminance, White	380 cd/m <sup>2</sup> (Center 1 point) (Typ.)
Viewing Angle (CR>10)	Viewing angle free ( R/L 178(Min.), U/D 178(Min.))
Power Consumption	Total 45.98 Watt (Logic=4.08 W , LED Driver =41.9W @ [ExtVbr_B=100%] )
Weight	5,620g (Typ.) 5,900g (Max)
Display Operating Mode	Transmissive mode, normally black
Surface Treatment	Hard coating(2H), Anti-glare treatment of the front polarizer (Haze 10%)

## Product Specification

## 2. Absolute Maximum Ratings

The following items are maximum values which, if exceeded, may cause faulty operation or permanent damage to the LCD module.

**Table 1. ABSOLUTE MAXIMUM RATINGS**

Parameter		Symbol	Value		Unit	Note
			Min	Max		
Power Input Voltage	LCD Circuit	V <sub>LCD</sub>	-0.3	+14.0	V <sub>DC</sub>	
	Driver	V <sub>BL</sub>	-0.3	+ 27.0	V <sub>DC</sub>	
Driver Control Voltage	ON/OFF	V <sub>OFF</sub> / V <sub>ON</sub>	-0.3	+5.5	V <sub>DC</sub>	1
	Brightness	V <sub>BR</sub>	0.0	+5.5	V <sub>DC</sub>	
T-Con Option Selection Voltage		V <sub>LOGIC</sub>	-0.3	+4.0	V <sub>DC</sub>	
Operating Temperature		T <sub>OP</sub>	0	+50	°C	2,3
Storage Temperature		T <sub>ST</sub>	-20	+60	°C	
Panel Front Temperature		T <sub>SUR</sub>	-	+68	°C	4
Operating Ambient Humidity		H <sub>OP</sub>	10	90	%RH	2,3
Storage Humidity		H <sub>ST</sub>	10	90	%RH	

Note1. Ambient temperature condition ( $T_a = 25 \pm 2 \text{ }^\circ\text{C}$ )

2. Temperature and relative humidity range are shown in the figure below.

Wet bulb temperature should be Max 39°C, and no condensation of water.

3. Gravity mura can be guaranteed below 40°C condition.

4. The maximum operating temperatures is based on the test condition that the surface temperature of display area is less than or equal to 68°C with LCD module alone in a temperature controlled chamber. Thermal management should be considered in final product design to prevent the surface temperature of display area from being over 68°C. The range of operating temperature may be degraded in case of improper thermal management in final product design.

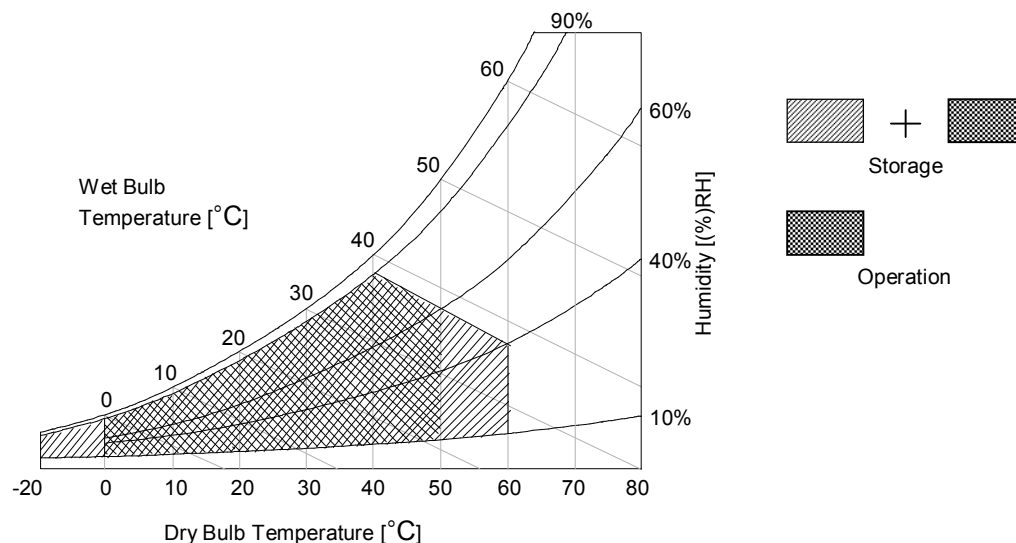

## Product Specification

### 3. Electrical Specifications

#### 3-1. Electrical Characteristics

It requires two power inputs. One is employed to power for the LCD circuit. The other is used for the LED backlight and LED Driver circuit.

**Table 2. ELECTRICAL CHARACTERISTICS**

Parameter	Symbol	Value			Unit	Note
		Min	Typ	Max		
<b>Circuit :</b>						
Power Input Voltage	$V_{LCD}$	10.8	12.0	13.2	$V_{DC}$	
Power Input Current	$I_{LCD}$	-	340	445	mA	1
		-	430	560	mA	2
Power Consumption	$P_{LCD}$	-	4.08	5.30	Watt	1
Rush current	$I_{RUSH}$	-	-	3.0	A	3

- Notes : 1. The specified current and power consumption are under the  $V_{LCD}=12.0V$ ,  $25 \pm 2^{\circ}C$ ,  $f_V=60Hz$  condition and mosaic pattern(8 x 6) is displayed and  $f_V$  is the frame frequency.
2. The current is specified at maximum current pattern.
3. The duration of rush current is about 2ms and rising time of power input is 0.5ms (min.).

White : 255 Gray  
Black : 0 Gray

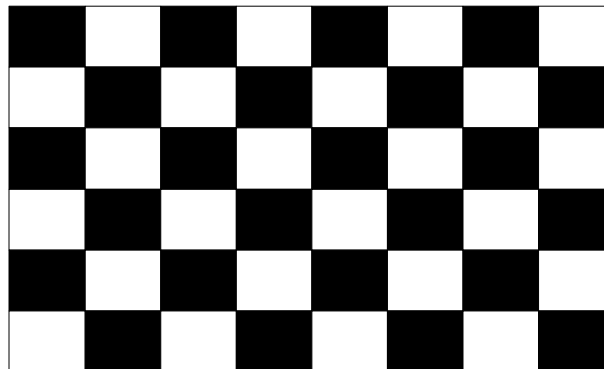

Mosaic Pattern(8 x 6)

## Product Specification

Table 3. ELECTRICAL CHARACTERISTICS (Continue)

Parameter	Symbol	Values			Unit	Notes		
		Min	Typ	Max				
LED Driver :								
Power Supply Input Voltage	VBL	22.8	24.0	26.4	Vdc	1		
Power Supply Input Current	IBL_A	-	1.7	1.9	A	Ext V <sub>BR-B</sub> = 100%		
Power Supply Input Current (In-Rush)	Irush	-	-	3.0	A	V <sub>BL</sub> = 22.8V Ext V <sub>BR-B</sub> = 100% 4		
Power Consumption	PBL	-	41.9	44.5	W	Ext V <sub>BR-B</sub> = 100%		
	On/Off	On	V on	2.5	-	5.0	Vdc	
		Off	V off	-0.3	0.0	0.7	Vdc	
	Brightness Adjust	ExtV <sub>BR-B</sub>	5	-	100	%	On Duty 6	
			1	-	100			
	PWM Frequency for NTSC & PAL	PAL		100		Hz	3	
		NTSC		120		Hz	3	
	Pulse Duty Level (PWM)	High Level	2.5	-	5.0	Vdc	HIGH : on duty LOW : off duty	
Low Level		0.0	-	0.7	Vdc			
LED :								
Life Time		30,000	50,000		Hrs	2		

## Notes :

- Electrical characteristics are determined after the unit has been 'ON' and stable for approximately 60 minutes at 25±2°C. The specified current and power consumption are under the typical supply Input voltage 24V and V<sub>BR</sub> (ExtV<sub>BR-B</sub> : 100%), it is total power consumption.
- The life time (MTTF) is determined as the time which luminance of the LED is 50% compared to that of initial value at the typical LED current (ExtV<sub>BR-B</sub> : 100%) on condition of continuous operating in LCM state at 25±2°C.
- LGD recommend that the PWM freq. is synchronized with One time harmonic of V<sub>sync</sub> signal of system. Though PWM frequency is over 120Hz (max 252Hz), function of LED Driver is not affected.
- The duration of rush current is about 200ms. This duration is applied to LED on time.
- Even though inrush current is over the specified value, there is no problem if I<sup>2</sup>T spec of fuse is satisfied.
- ExtV<sub>BR-B</sub> signal have to input available duty range and sequence.  
After Driver ON signal is applied, ExtV<sub>BR-B</sub> should be sustained from 5% to 100% more than 500ms.  
After that, ExtV<sub>BR-B</sub> 1% and 100% is possible  
For more information, please see 3-6-2. Sequence for LED Driver.

## Product Specification

**3-2. Interface Connections**

This LCD module employs two kinds of interface connection, a 30-pin connector is used for the module electronics and 14-pin connector is used for the integral backlight system.

**3-2-1. LCD Module**

- LCD Connector(CN1) : KDF71G-30S-1H(Hirose) or Compatible.
- Mating Connector : : FI-X30C2L (Manufactured by JAE) or Equivalent

**Table 4. MODULE CONNECTOR(CN1) PIN CONFIGURATION**

Pin No.	Symbol	Description	Note
1	VLCD	Power Supply +12.0V	
2	VLCD	Power Supply +12.0V	
3	VLCD	Power Supply +12.0V	
4	VLCD	Power Supply +12.0V	
5	GND	Ground	
6	GND	Ground	
7	GND	Ground	
8	GND	Ground	
9	LVDS Select	'H' =JEIDA , 'L' or NC = VESA	Appendix IV
10	NC	No Connection	4
11	GND	Ground	
12	RA-	LVDS Receiver Signal(-)	
13	RA+	LVDS Receiver Signal(+)	
14	GND	Ground	
15	RB-	LVDS Receiver Signal(-)	
16	RB+	LVDS Receiver Signal(+)	
17	GND	Ground	
18	RC-	LVDS Receiver Signal(-)	
19	RC+	LVDS Receiver Signal(+)	
20	GND	Ground	
21	RCLK-	LVDS Receiver Clock Signal(-)	
22	RCLK+	LVDS Receiver Clock Signal(+)	
23	GND	Ground	
24	RD-	LVDS Receiver Signal(-)	
25	RD+	LVDS Receiver Signal(+)	
26	GND	Ground	
27	NC	No Connection	4
28	NC	No Connection	4
29	NC	No Connection	4
30	GND	Ground	

- Notes :
1. All GND (Ground) pins should be connected together to the LCD module's metal frame.
  2. All VLCD (power input) pins should be connected together.
  3. All Input levels of LVDS signals are based on the EIA 644 Standard.
  4. These pins are used only for LGD (Do not connect)
  5. Specific pin No. #30 is used for "No signal detection" of system signal interface.  
It should be GND for NSB (No Signal Black) while the system interface signal is not.  
If this pin is "H", LCD Module displays AGP (Auto Generation Pattern).



## Product Specification

**3-2-2. Backlight Module**

Master

-LED Driver Connector

: 20022WR - H14B1(Yeonho) or Equivalent

- Mating Connector

: 20022HS - 14B2 or Equivalent

Table 5. LED DRIVER CONNECTOR PIN CONFIGURATION

Pin No	Symbol	Description	Note
1	VBL	Power Supply +24.0V	
2	VBL	Power Supply +24.0V	
3	VBL	Power Supply +24.0V	
4	VBL	Power Supply +24.0V	
5	VBL	Power Supply +24.0V	
6	GND	Backlight Ground	1
7	GND	Backlight Ground	
8	GND	Backlight Ground	
9	GND	Backlight Ground	
10	GND	Backlight Ground	
11	Status	Back Light Status	2
12	VON/OFF	Backlight ON/OFF control	
13	NC	Don't care	
14	EXTVBR-B	External PWM	

Notes : 1. GND should be connected to the LCD module's metal frame.

2. Normal : Low (under 0.7V) / Abnormal : High (upper 3.0V)

3. High : on duty / Low : off duty, Pin#14 can be opened. ( if Pin #14 is open , EXTVBR-B is 100% )

4. Each impedance of pin #12 and 14 is over 50 [KΩ] .

## ◆ Rear view of LCM

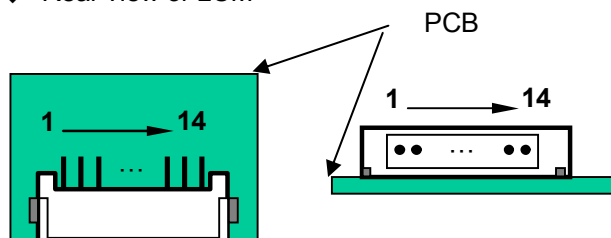

&lt;Master&gt;

## Product Specification

### 3-3. Signal Timing Specifications

Table 6 shows the signal timing required at the input of the LVDS transmitter. All of the interface signal timings should be satisfied with the following specification for normal operation.

Table 6-1. TIMING TABLE (DE Only Mode)

ITEM		Symbol	Min	Typ	Max	Unit	Note
Horizontal	Display Period	t <sub>HV</sub>	-	1366	-	tclk	
	Blank	t <sub>HB</sub>	90	162	410	tclk	
	Total	t <sub>HP</sub>	1456	1528	1776	tclk	
Vertical	Display Period	t <sub>VV</sub>	-	768	-	tHP	
	Blank	t <sub>VB</sub>	20 (126)	22 (180)	240 (295)	tHP	1
	Total	t <sub>VP</sub>	788 (894)	790 (948)	1008 (1063)	tHP	
ITEM		Symbol	Min	Typ	Max	Unit	Note
Frequency	DCLK	f <sub>CLK</sub>	63.0	72.4	80.0	MHz	
	Horizontal	f <sub>H</sub>	45	47.4	55	KHz	2
	Vertical	f <sub>V</sub>	57 (47)	60 (50)	63 (53)	Hz	2 NTSC : 57~63Hz (PAL : 47~53Hz)

Note: 1. The input of HSYNC & VSYNC signal does not have an effect on normal operation (DE Only Mode).  
If you use spread spectrum of EMI, add some additional clock to minimum value for clock margin.

2. The performance of the electro-optical characteristics may be influenced by variance of the vertical refresh rate and the horizontal frequency

※ Timing should be set based on clock frequency.

Product Specification

3-4. Signal Timing Waveforms

3-4-1. LVDS Input Signal Timing Diagram

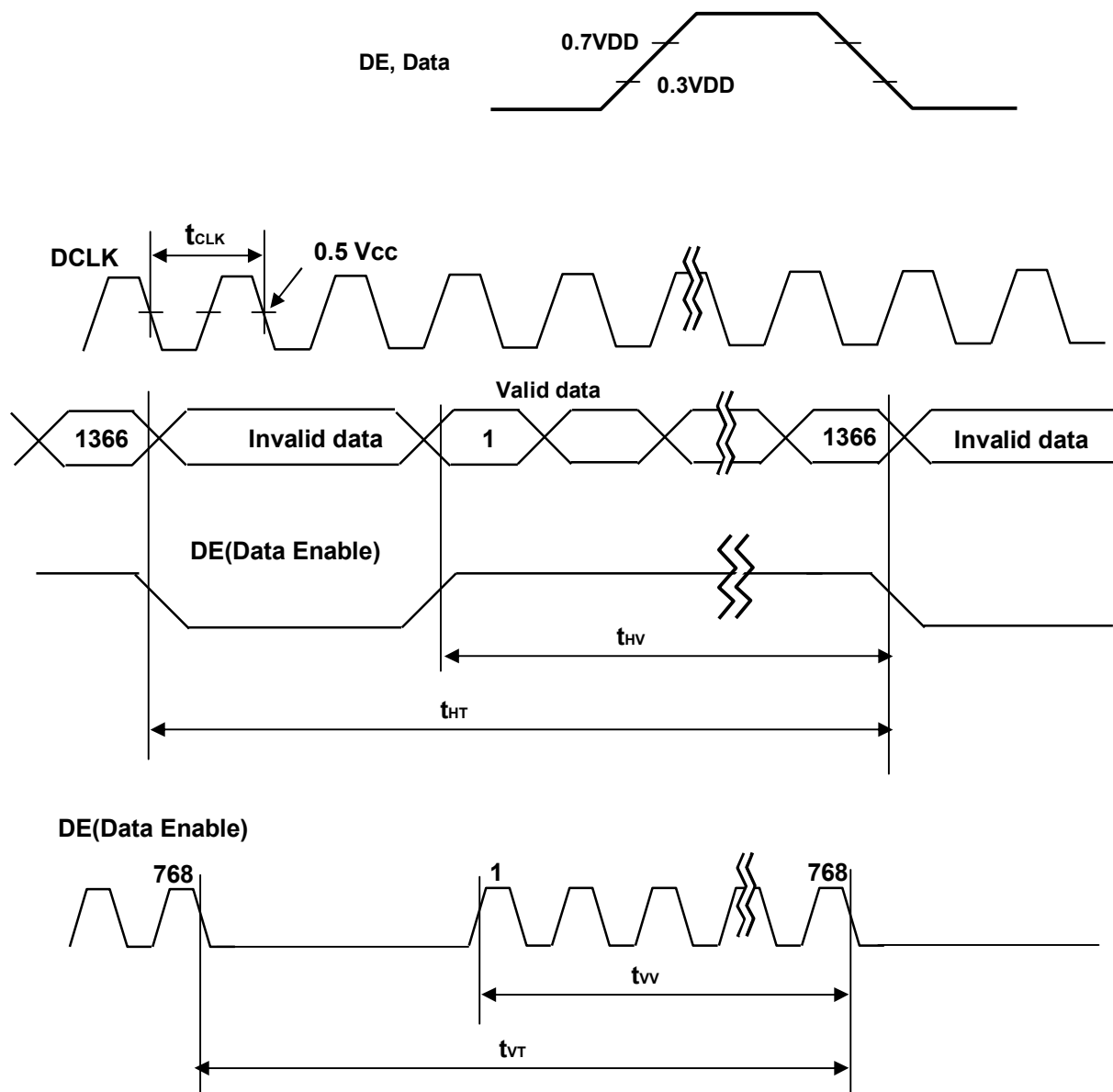

Product Specification

**3-4-2. LVDS Input Signal Characteristics**

**1) DC Specification**

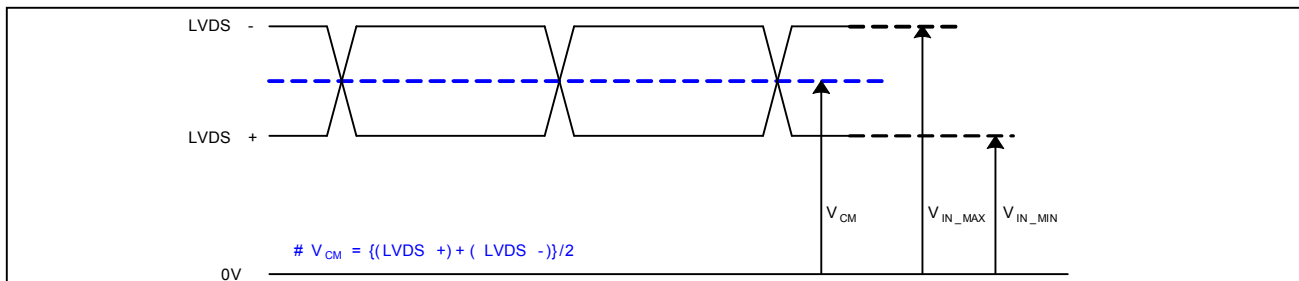

Description	Symbol	Min	Max	Unit	Note
LVDS Common mode Voltage	$V_{CM}$	1.0	1.5	V	-
LVDS Input Voltage Range	$V_{IN}$	0.7	1.8	V	-
Change in common mode Voltage	$\Delta V_{CM}$	-	250	mV	-

**2) AC Specification**

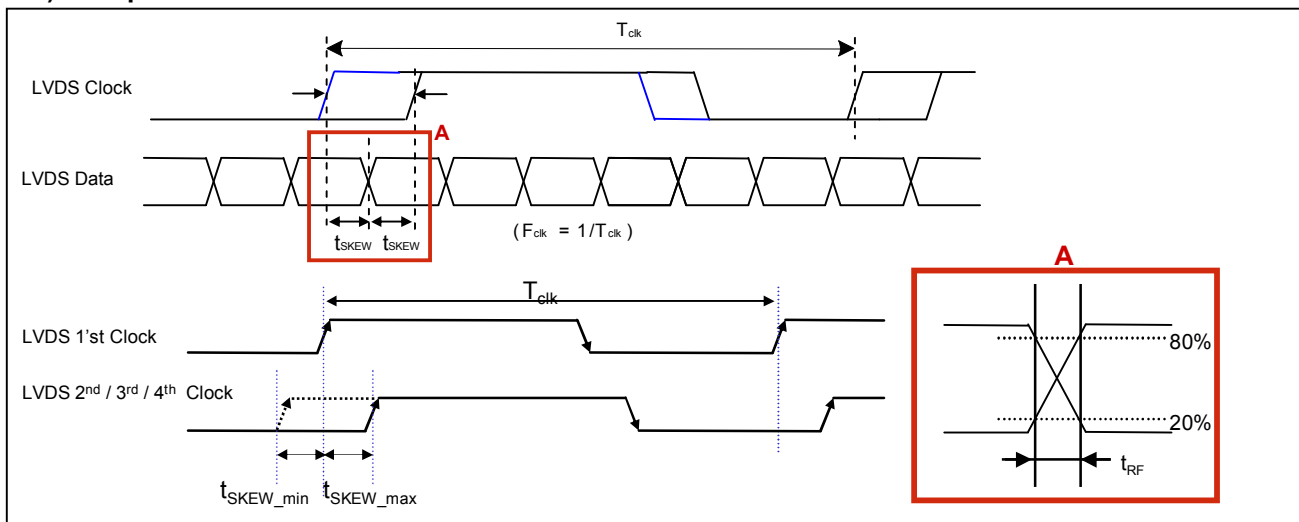

Description	Symbol	Min	Max	Unit	Note	
LVDS Differential Voltage	High Threshold	$V_{TH}$	100	300	mV	3
	Low Threshold	$V_{TL}$	-300	-100	mV	
LVDS Clock to Data Skew	$t_{SKEW}$	-	$ (0.20 \cdot T_{clk})/7 $	ps	-	
LVDS Clock/DATA Rising/Falling time	$t_{RF}$	260	$ (0.3 \cdot T_{clk})/7 $	ps	2	
Effective time of LVDS	$t_{eff}$	$ \pm 360 $	-	ps	-	
LVDS Clock to Clock Skew (Even to Odd)	$t_{SKEW\_EO}$	-	$ 1/7 \cdot T_{clk} $	ps	-	

- Note
1. All Input levels of LVDS signals are based on the EIA 644 Standard.
  2. If  $t_{RF}$  isn't enough,  $t_{eff}$  should be meet the range.
  3. LVDS Differential Voltage is defined within  $t_{eff}$

Product Specification

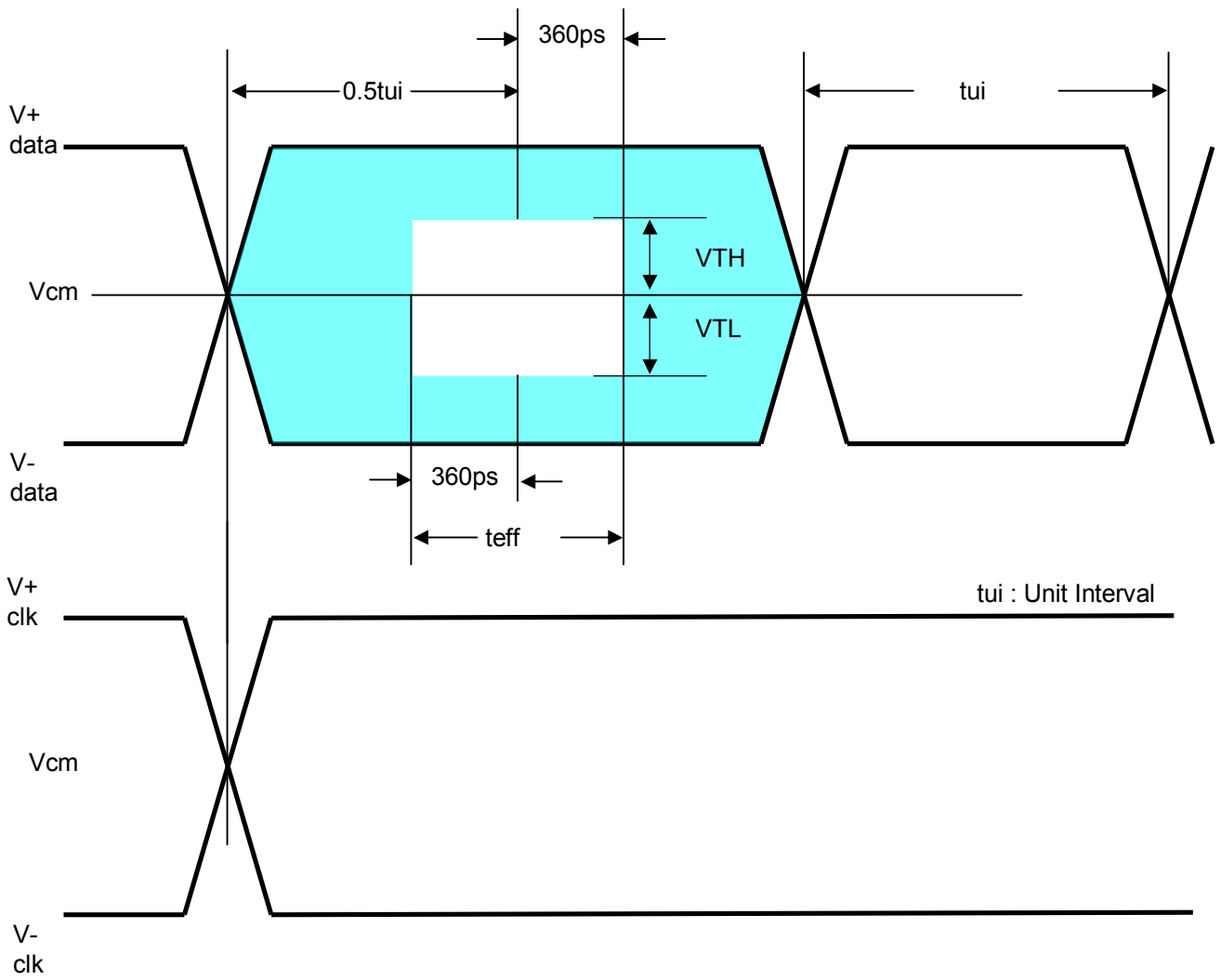

Product Specification

**3-5. Color Data Reference**

The brightness of each primary color (Red, Green, Blue) is based on the 8-bit gray scale data input for the color. The higher binary input, the brighter the color. Table 7 provides a reference for color versus data input.

**Table 7. COLOR DATA REFERENCE**

Color		Input Color Data																							
		RED								GREEN								BLUE							
		MSB				LSB				MSB				LSB				MSB				LSB			
		R7	R6	R5	R4	R3	R2	R1	R0	G7	G6	G5	G4	G3	G2	G1	G0	B7	B6	B5	B4	B3	B2	B1	B0
Basic Color	Black	0	0	0	0	0	0	0	0	0	0	0	0	0	0	0	0	0	0	0	0	0	0	0	0
	Red (255)	1	1	1	1	1	1	1	1	0	0	0	0	0	0	0	0	0	0	0	0	0	0	0	0
	Green (255)	0	0	0	0	0	0	0	0	1	1	1	1	1	1	1	1	0	0	0	0	0	0	0	0
	Blue (255)	0	0	0	0	0	0	0	0	0	0	0	0	0	0	0	0	1	1	1	1	1	1	1	1
	Cyan	0	0	0	0	0	0	0	0	1	1	1	1	1	1	1	1	1	1	1	1	1	1	1	1
	Magenta	1	1	1	1	1	1	1	1	0	0	0	0	0	0	0	0	1	1	1	1	1	1	1	1
	Yellow	1	1	1	1	1	1	1	1	1	1	1	1	1	1	1	1	0	0	0	0	0	0	0	0
	White	1	1	1	1	1	1	1	1	1	1	1	1	1	1	1	1	1	1	1	1	1	1	1	1
RED	RED (000) Dark	0	0	0	0	0	0	0	0	0	0	0	0	0	0	0	0	0	0	0	0	0	0	0	0
	RED (001)	0	0	0	0	0	0	0	1	0	0	0	0	0	0	0	0	0	0	0	0	0	0	0	0
	...	...								...								...							
	RED (254)	1	1	1	1	1	1	1	0	0	0	0	0	0	0	0	0	0	0	0	0	0	0	0	0
	RED (255)	1	1	1	1	1	1	1	1	0	0	0	0	0	0	0	0	0	0	0	0	0	0	0	0
GREEN	GREEN (000) Dark	0	0	0	0	0	0	0	0	0	0	0	0	0	0	0	0	0	0	0	0	0	0	0	0
	GREEN (001)	0	0	0	0	0	0	0	0	0	0	0	0	0	0	0	1	0	0	0	0	0	0	0	0
	...	...								...								...							
	GREEN (254)	0	0	0	0	0	0	0	0	1	1	1	1	1	1	1	0	0	0	0	0	0	0	0	0
	GREEN (255)	0	0	0	0	0	0	0	0	1	1	1	1	1	1	1	1	0	0	0	0	0	0	0	0
BLUE	BLUE (000) Dark	0	0	0	0	0	0	0	0	0	0	0	0	0	0	0	0	0	0	0	0	0	0	0	0
	BLUE (001)	0	0	0	0	0	0	0	0	0	0	0	0	0	0	0	0	0	0	0	0	0	0	0	1
	...	...								...								...							
	BLUE (254)	0	0	0	0	0	0	0	0	0	0	0	0	0	0	0	0	1	1	1	1	1	1	1	0
	BLUE (255)	0	0	0	0	0	0	0	0	0	0	0	0	0	0	0	0	1	1	1	1	1	1	1	1

## Product Specification

## 3-6. Power Sequence

## 3-6-1. LCD Driving circuit

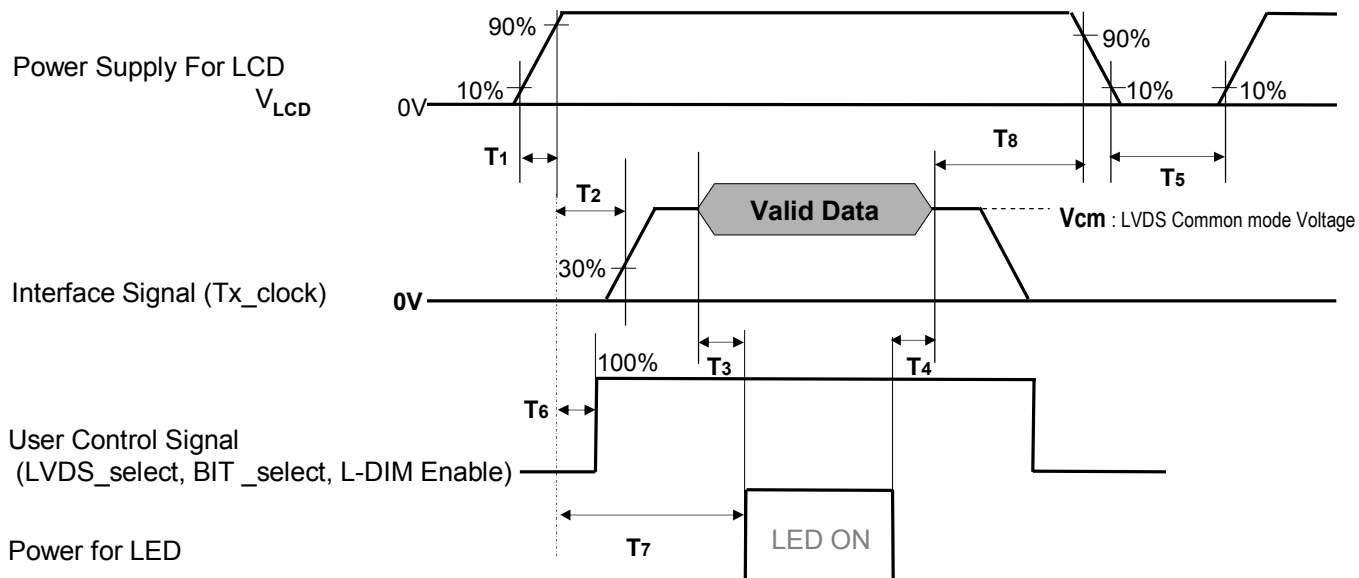

Table 8. POWER SEQUENCE

Parameter	Value			Unit	Notes
	Min	Typ	Max		
T1	0.5	-	20	ms	1
T2	0	-	-	ms	2
T3	200	-	-	ms	3
T4	200	-	-	ms	3
T5	1.0	-	-	s	4
T6	-	-	T2	ms	5
T7	0.5	-	-	s	6
T8	100	-	-	ms	7

- Note :
1. Even though T1 is over the specified value, there is no problem if I2T spec of fuse is satisfied.
  2. If T2 is satisfied with specification after removing LVDS Cable, there is no problem.
  3. The T3 / T4 is recommended value, the case when failed to meet a minimum specification, abnormal display would be shown. There is no reliability problem.
  4. T5 should be measured after the Module has been fully discharged between power off and on period.
  5. If the on time of signals (Interface signal and user control signals) precedes the on time of Power ( $V_{LCD}$ ), it will be happened abnormal display. When T6 is NC status, T6 doesn't need to be measured.
  6. If there is no abnormal display, no problem.
  7. It is recommendation specification that T8 has to be 100ms as a minimum value.
    - ※ Please avoid floating state of interface signal at invalid period.
    - ※ When the power supply for LCD (VLCD) is off, be sure to pull down the valid and invalid data to 0V.

Product Specification

3-6-2. Sequence for LED Driver

Power Supply For LED Driver

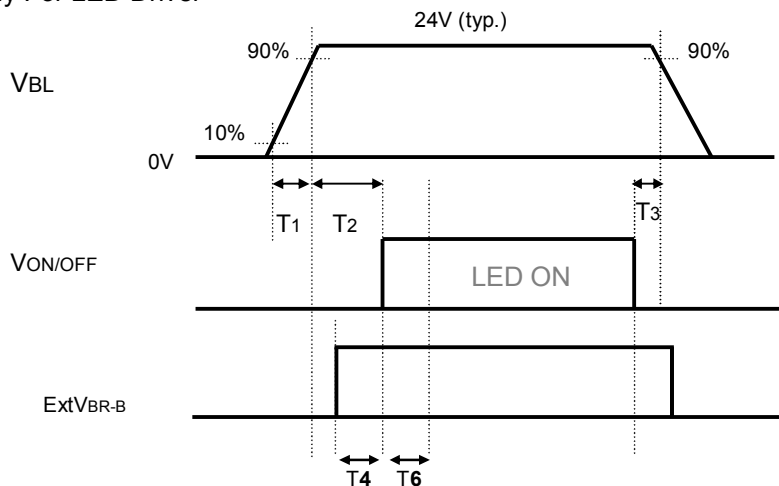

3-6-3. Dip condition for LED Driver

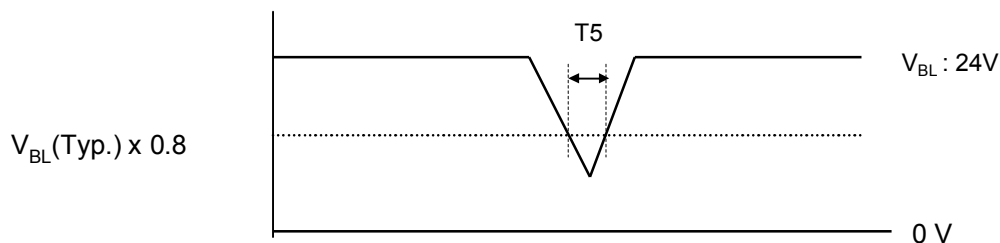

Table 9. Power Sequence for LED Driver

Parameter	Values			Units	Remarks
	Min	Typ	Max		
T1	20	-	-	ms	1
T2	500	-	-	ms	
T3	10	-	-	ms	
T4	0	-	-	ms	
T5	-	-	10	ms	$V_{BL}(Typ) \times 0.8$
T6	500	-	-	ms	2

- Notes : 1. T1 describes rising time of 0V to 24V and this parameter does not applied at restarting time.  
 Even though T1 is over the specified value, there is no problem if I<sup>2</sup>T spec of fuse is satisfied.  
 2. In T6 section, ExtVBR-B should be sustained from 5% to 100% .



Product Specification

4. Optical Specification

Optical characteristics are determined after the unit has been 'ON' and stable in a dark environment at  $25\pm 2^{\circ}\text{C}$ . The values are specified at distance 50cm from the LCD surface at a viewing angle of  $\phi$  and  $\theta$  equal to  $0^{\circ}$ . FIG. 1 shows additional information concerning the measurement equipment and method.

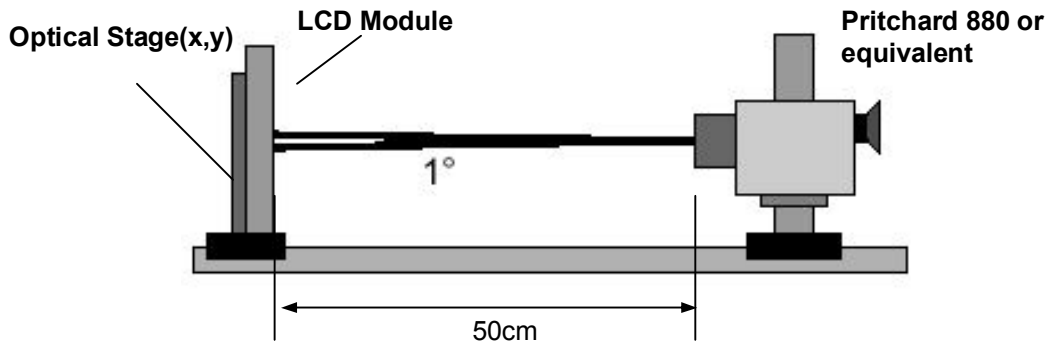

FIG. 1 Optical Characteristic Measurement Equipment and Method

$T_a = 25\pm 2^{\circ}\text{C}$ ,  $V_{LCD} = 12.0\text{V}$ ,  $f_v = 60\text{Hz}$ ,  $D_{clk} = 72.4\text{MHz}$ ,  $EXTV_{BR\_B} = 100\%$

Table 10. OPTICAL CHARACTERISTICS

Parameter	Symbol	Value			Unit	Note		
		Min	Typ	Max				
Contrast Ratio	CR	850	1200	-		1		
Surface Luminance, white	$L_{WH}$	300	380		cd/m <sup>2</sup>	2		
		110	135					
Luminance Variation	$\delta_{WHITE}$ 5P	-	-	1.3		3		
Response Time	Variation	G to G <sub><math>\sigma</math></sub>	6	9	ms	5		
	Gray to Gray(BW)	G to G <sub>BW</sub>	9	13	ms	4		
Color Coordinates [CIE1931]	RED	Rx	Typ -0.03	0.637	Typ +0.03			
		Ry		0.341				
	GREEN	Gx		0.318				
		Gy		0.606				
	BLUE	Bx		0.153				
		By		0.057				
	WHITE	Wx		0.279				
Wy		0.292						
Color Temperature			10,000		K			
Color Gamut			68		%			
Viewing Angle (CR>10)								
Viewing Angle	2D (CT>10)	x axis, right( $\phi=0^{\circ}$ )	$\theta_r$	89	-	-	degree	6
		x axis, left ( $\phi=180^{\circ}$ )	$\theta_l$	89	-	-		
		y axis, up ( $\phi=90^{\circ}$ )	$\theta_u$	89	-	-		
		y axis, down ( $\phi=270^{\circ}$ )	$\theta_d$	89	-	-		
	3D (CT≤10%)	up + down	$\theta_u$ (y axis) + $\theta_d$ (y axis)	6	10		degree	8
Gray Scale				-			7	

Product Specification

Notes : 1. Contrast Ratio (CR) is defined mathematically as :

$$CR = \frac{\text{Surface Luminance at all white pixels}}{\text{Surface Luminance at all black pixels}}$$

It is measured at center 1-point.

2. Surface luminance is determined after the unit has been 'ON' and 1Hour after lighting the backlight in a dark environment at 25±2°C. Surface luminance is the luminance value at center 1-point across the LCD surface 50cm from the surface with all pixels displaying white.

For more information see the FIG. 2.

3. The variation in surface luminance, δ WHITE is defined as :

$$\delta \text{ WHITE}(5P) = \text{Maximum}(L_{on1}, L_{on2}, L_{on3}, L_{on4}, L_{on5}) / \text{Minimum}(L_{on1}, L_{on2}, L_{on3}, L_{on4}, L_{on5})$$

Where  $L_{on1}$  to  $L_{on5}$  are the luminance with all pixels displaying white at 5 locations .

For more information, see the FIG. 2.

4. Response time is the time required for the display to transit from any gray to white (Rise Time,  $Tr_R$ ) and from any gray to black (Decay time,  $Tr_D$ ). For additional information see the FIG. 3.

※ G to  $G_{BW}$  Spec stands for average value of all measured points.

Photo Detector : RD-80S / Field : 2 °

5. G to  $G_{\sigma}$  is Variation of Gray to Gray response time composing a picture

$$G \text{ to } G (\sigma) =$$

$$\sqrt{\frac{\sum(Xi- u)^2}{N}}$$

$Xi$  = Individual Data

$u$  = Data average

$N$  = The number of Data

6. Viewing angle is the angle at which the contrast ratio is greater than 10. The angles are determined for the horizontal or x axis and the vertical or y axis with respect to the z axis which is normal to the LCD module surface. For more information, see the FIG. 4.

7. Gray scale specification

Gamma Value is approximately 2.2. For more information, see the Table 11.

8. 3D performance specification is expressed by 3D luminance and 3D viewing angle.

**Table 11. GRAY SCALE SPECIFICATION**

Gray Level	Luminance [%] (Typ.)
L0	0.08
L15	0.27
L31	1.04
L47	2.49
L63	4.68
L79	7.66
L95	11.5
L111	16.1
L127	21.6
L143	28.1
L159	35.4
L175	43.7
L191	53.0
L207	63.2
L223	74.5
L239	86.7
L255	100

Product Specification

Measuring point for surface luminance & measuring point for luminance variation.

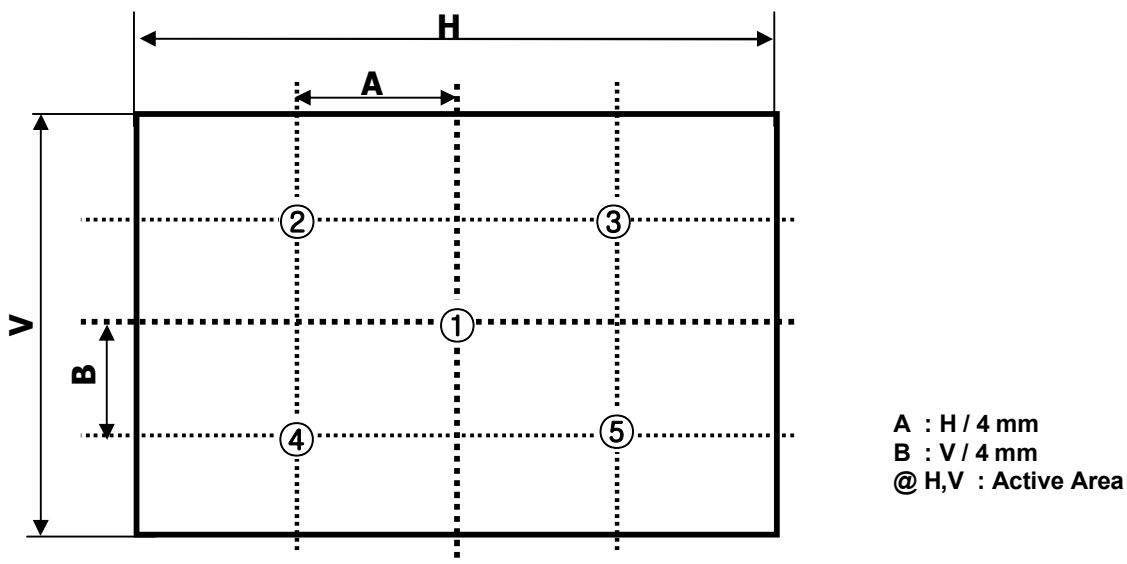

FIG. 2 5 Points for Luminance Measure

Response time is defined as the following figure and shall be measured by switching the input signal for “Gray(N)” and “Black or White”.

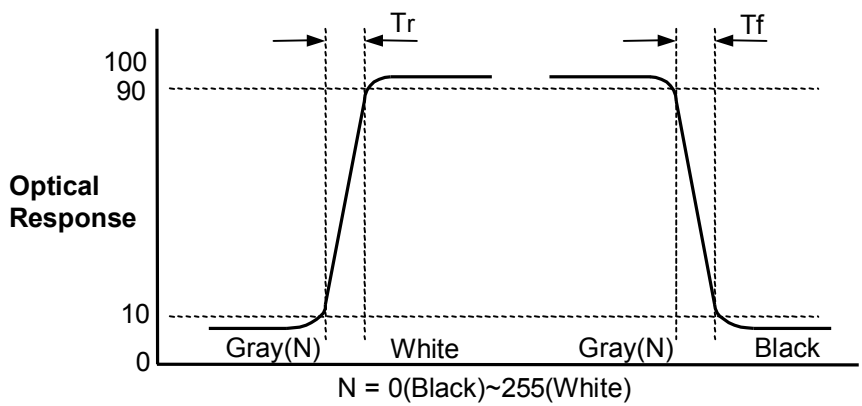

FIG. 3 Response Time

## Product Specification

Dimension of viewing angle range

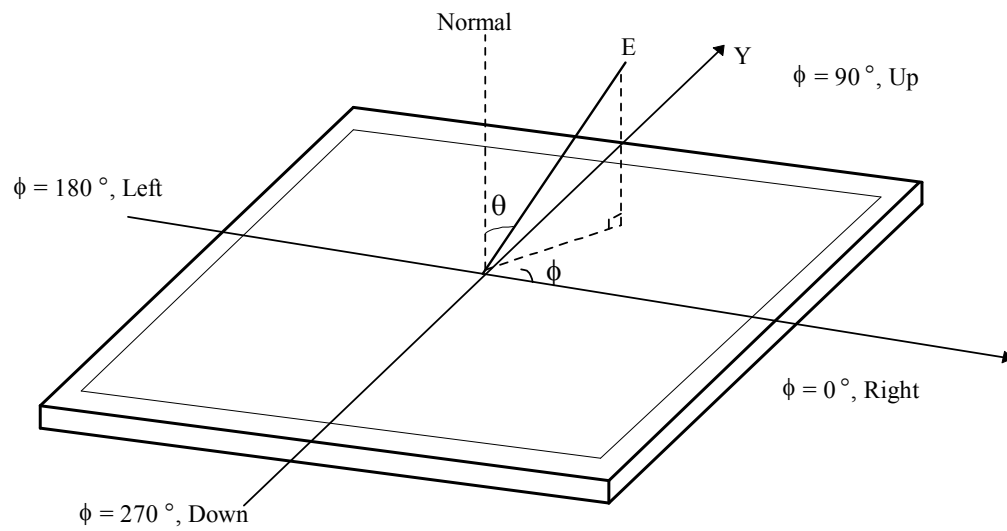
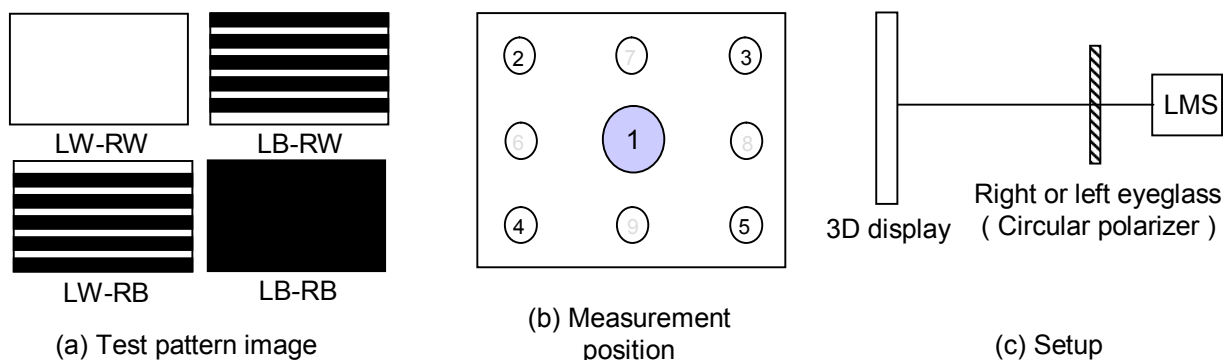
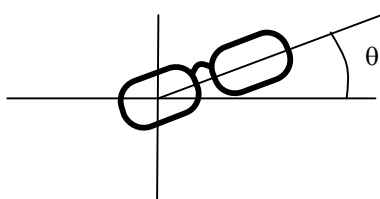

FIG. 4 Viewing Angle

## Product Specification



&lt; FIG. 6. Measurement configuration &gt;



&lt; FIG. 7. Positioning eyeglass &gt;

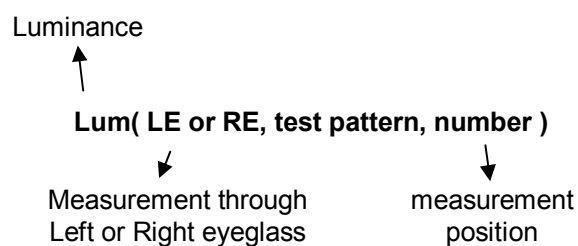

&lt; FIG. 8. notation of luminance measurement &gt;

In order to measure 3D luminance, 3D crosstalk and 3D viewing angle, it need to be prepared as below;

## 1) Measurement configuration

4-Test pattern images. Refer to FIG 6.

- LW-RW : White for left and right eye
- LW-RB : White for left eye and Black for right eye
- LB-RW : Black for left eye and white for right eye
- LB-RB : Black for left eye and right eye

Image files where black and white lines are displayed on even or odd lines.

Luminance measurement system (LMS) with narrow FOV (field of view) is used. Refer to FIG 1.

## 2) Positioning Eyeglass (refer to appendix-VII for standard specification of eyeglass)

Find angle of minimum transmittance.

This value would be provided beforehand or measured by the following steps;

- (i) Test image (LB-RW) is displayed.
- (ii) Left eyeglass are placed in front of LMS and luminance is measured, rotating right eyeglass such as FIG 7. The notation for luminance measurement is "Lum(LE, LB-RW,1)".
- (iii) Find the angle where luminance is minimum.

\* Following measurements should be performed at the angle of minimum transmittance of eyeglass.

## Product Specification

## 3) Measurement of 3D luminance

- (i) Test image ( LW-RW ) is displayed.
- (ii) Left or right eyeglass are placed in front of LMS successively and luminance is measured at center 1 point where the notation for luminance measurement is "Lum(LE, LW-RW,1)" or "Lum(RE, LW-RW,1).

## 4) Measurement of 3D crosstalk

- (i) Test image ( LB-RW, LW-RB and LB-RB ) is displayed.
- (ii) Right or left eyeglass are placed in front of LMS successively and luminance is measured for position 1. with rotating LMS or sample vertically.

$$\text{Average of } \frac{\text{Lum(LE, LB-RW,1)} - \text{Lum(LE, LB-RB,1)}}{\text{Lum(LE, LW-RB,1)} - \text{Lum(LE, LB-RB,1)}}$$

and

$$\frac{\text{Lum(RE, LW-RB,1)} - \text{Lum(RE, LB-RB,1)}}{\text{Lum(RE, LB-RW,1)} - \text{Lum(RE, LB-RB,1)}}$$

## 5) Measurement of 3D Viewing Angle

3D viewing angle is the angle at which the 3D crosstalk is under 10%. The angles are determined for the vertical or y axis with respect to the z axis which is normal to the LCD module surface and measured for position 1. For more information , see the Fig 9

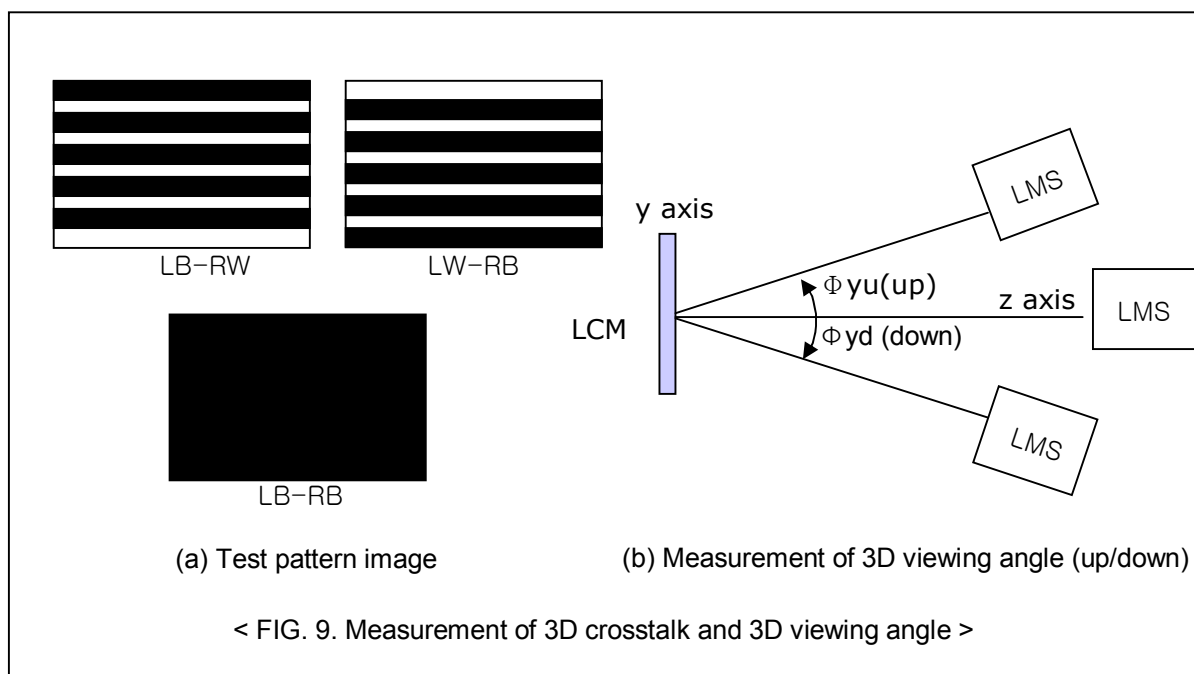

## Product Specification

**5. Mechanical Characteristics**

Table 12 provides general mechanical characteristics.

**Table 12. MECHANICAL CHARACTERISTICS**

Item	Value	
Outline Dimension	Horizontal	735.4mm
	Vertical	433.0 mm
	Depth	10.8 mm
Bezel Area	Horizontal	705.4mm
	Vertical	400.0mm
Active Display Area	Horizontal	697.6845mm
	Vertical	392.256mm
Weight	5,620g (Typ.), 5,900g (Max.)	

Note : 1.Please refer to a mechanical drawing in terms of tolerance at the next page.

Product Specification

<FRONT VIEW>

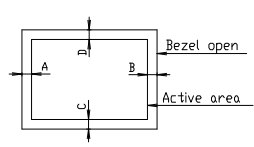
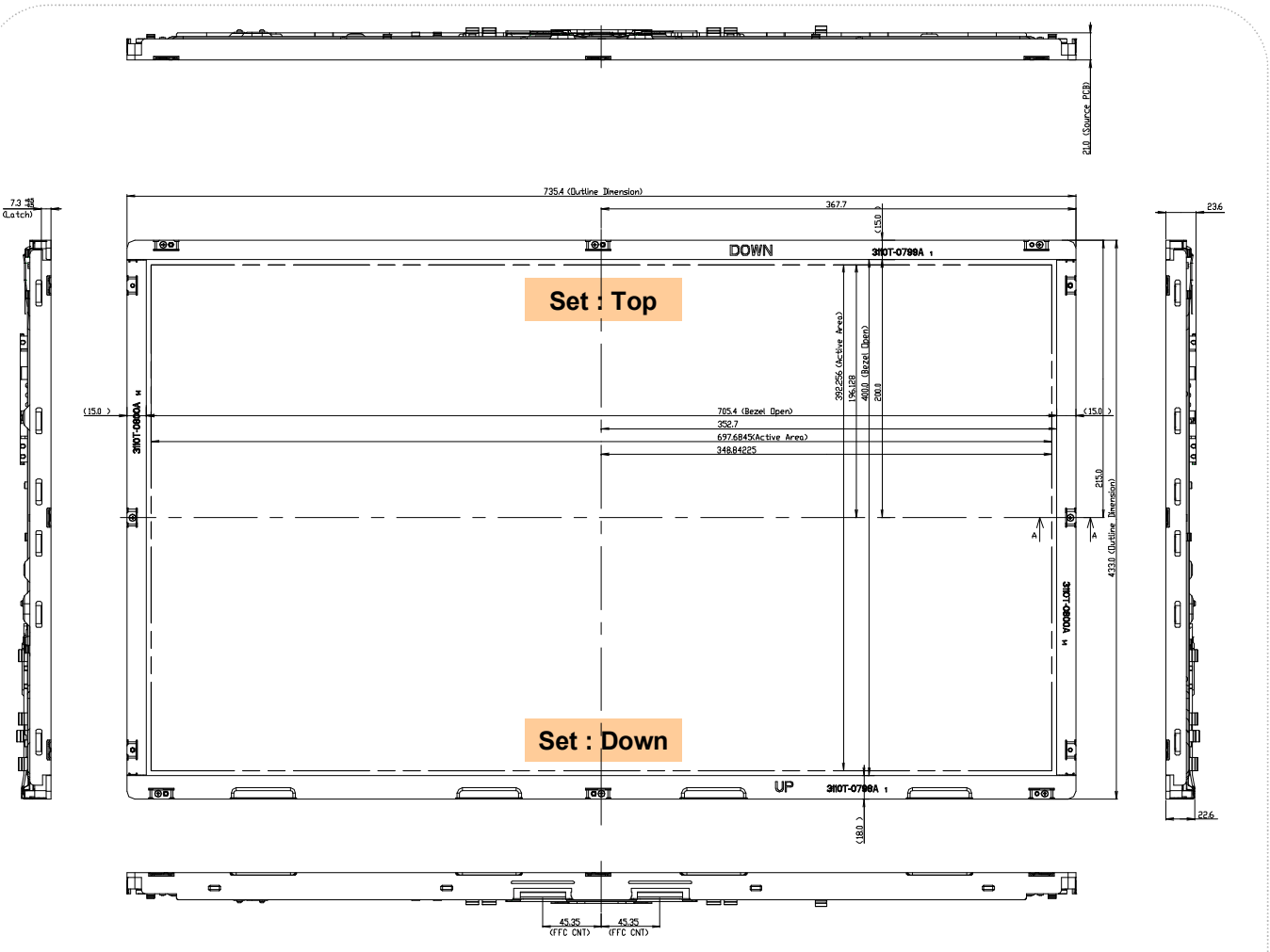

- NOTES
1. Unspecified tolerances are to be ± 10mm.
  2. This drawing is only preliminary data and can be changed without notice.
  3. TTT and partial disposition tolerance of display area is as following.
    - (1) X-Direction : IA-BI 1.5%
    - (2) Y-Direction : IC-DI 1.5%

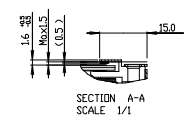



Product Specification

<REAR VIEW>

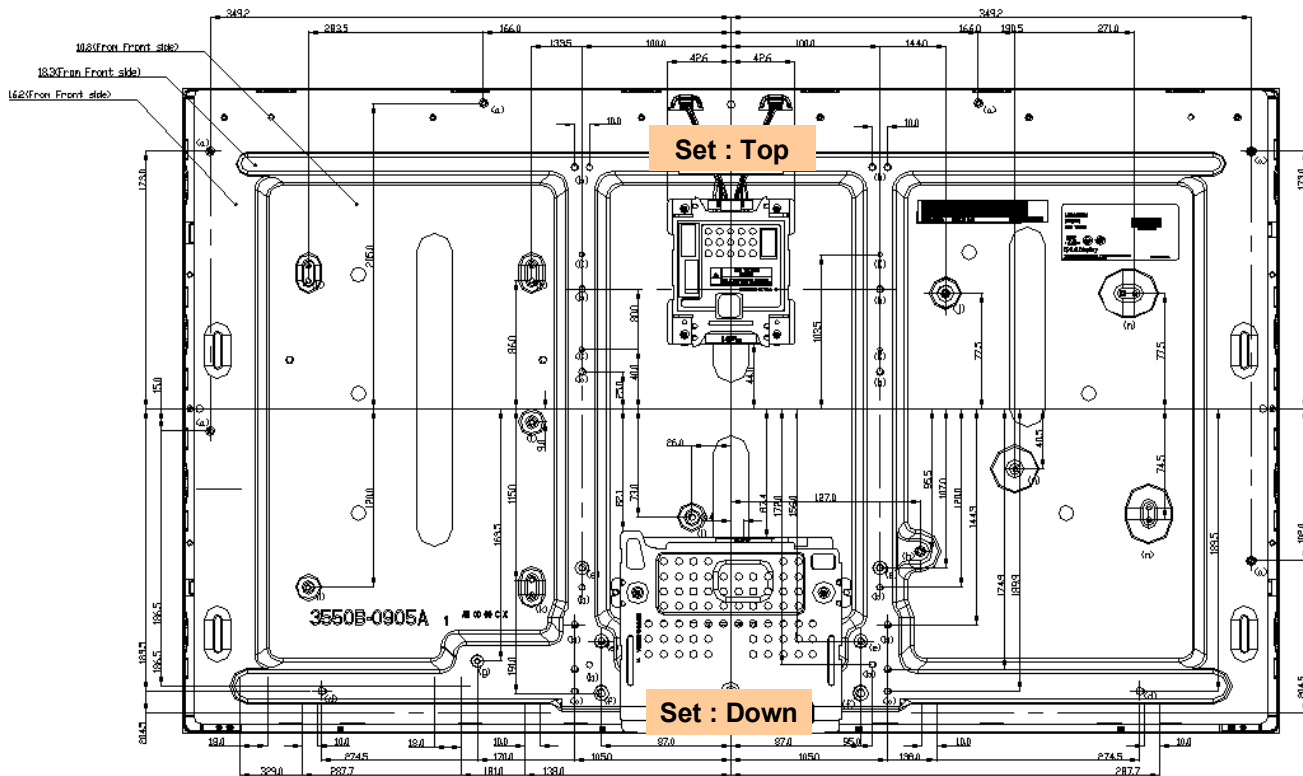

ITEM	TAP	Max. Depth (mm)	Torque (gf·cm)	NOTES
(a)	M3	7.0	Max.6D	
(b)	M4	5.0	Max.8D	
(c)	M3	5.0	Max.6D	
(d)	M5	5.0	Max.10D	
(e)	M4	10.0	Max.8D	
(f)	M5	10.0	Max.10D	
(g)	M3	10.0	Max.6D	
(h)	M5	7.0	Max.6D	
(i)	M5	7.0	Max.6D	
(j)	M3	3.0	Max.6D	
(k)	M3	3.0	Max.6D	
(l)	M3	3.0	Max.6D	
(m)	M5	7.0	Max.6D	
(n)	M3	7.0	Max.6D	

## Product Specification

**6. Reliability****Table 13. ENVIRONMENT TEST CONDITION**

No.	Test Item	Condition
1	High temperature storage test	Ta= 60°C, 240h
2	Low temperature storage test	Ta= -20°C, 240h
3	High temperature operation test	Ta= 50°C, 50%RH, 240h
4	Low temperature operation test	Ta= 0°C, 240h
5	Vibration test (non-operating)	Wave form : random Vibration level : 1.0Grms Bandwidth : 10-300Hz Duration : X,Y,Z, 30 min Each direction per 10 min
6	Shock test (non-operating)	Shock level : 50Grms Waveform : half sine wave, 11ms Direction : ±X, ±Y, ±Z One time each direction
7	Humidity condition Operation	Ta= 40 °C, 90%RH
8	Altitude operating storage / shipment	0 - 15,000 ft 0 - 40,000 ft

Note : Before and after Reliability test, LCM should be operated with normal function.

## 7. International Standards

### 7-1. Safety

- a) UL 60065, Seventh Edition, Underwriters Laboratories Inc.  
Audio, Video and Similar Electronic Apparatus - Safety Requirements.
- b) CAN/CSA C22.2 No.60065:03, Canadian Standards Association.  
Audio, Video and Similar Electronic Apparatus - Safety Requirements.
- c) EN 60065:2002 + A11:2008, European Committee for Electrotechnical Standardization (CENELEC).  
Audio, Video and Similar Electronic Apparatus - Safety Requirements.
- d) IEC 60065:2005 + A1:2005, The International Electrotechnical Commission (IEC).  
Audio, Video and Similar Electronic Apparatus - Safety Requirements.  
(Including report of IEC60825-1:2001 clause 8 and clause 9)

#### Notes

##### 1. Laser (LED Backlight) Information

Class 1M LED Product IEC60825-1 : 2001 Embedded LED Power (Class 1M)
--

##### 2. Caution

- : LED inside.
- Class 1M laser (LEDs) radiation when open.
- Do not open while operating.

### 7-2. EMC

- a) ANSI C63.4 "American National Standard for Methods of Measurement of Radio-Noise Emissions from Low-Voltage Electrical and Electronic Equipment in the Range of 9 kHz to 40 GHz." American National Standards Institute (ANSI), 2003.
- b) CISPR 22 "Information technology equipment – Radio disturbance characteristics – Limit and methods of measurement." International Special Committee on Radio Interference (CISPR), 2005.
- c) CISPR 13 "Sound and television broadcast receivers and associated equipment – Radio disturbance characteristics – Limits and method of measurement." International Special Committee on Radio Interference (CISPR), 2006.

### 7-3. Environment

- a) RoHS, Directive 2002/95/EC of the European Parliament and of the council of 27 January 2003

## Product Specification

**8. Packing****8-1. Information of LCM Label**

## a) Lot Mark

A	B	C	D	E	F	G	H	I	J	K	L	M
---	---	---	---	---	---	---	---	---	---	---	---	---

A,B,C : SIZE(INCH)  
E : MONTH

D : YEAR  
F ~ M : SERIAL NO.

## Note

## 1. YEAR

Year	2011	2012	2013	2014	2015	2016	2017	2018	2019	2020
Mark	A	B	C	D	E	F	G	H	J	K

## 2. MONTH

Month	Jan	Feb	Mar	Apr	May	Jun	Jul	Aug	Sep	Oct	Nov	Dec
Mark	1	2	3	4	5	6	7	8	9	A	B	C

## b) Location of Lot Mark

Serial No. is printed on the label. The label is attached to the backside of the LCD module.  
This is subject to change without prior notice.

**8-2. Packing Form**

- a) Package quantity in one Pallet : 6 pcs
- b) Pallet Size : 1140 mm X 870 mm X 1161 mm.

## Product Specification

### 9. Precautions

Please pay attention to the followings when you use this TFT LCD module.

#### 9-1. Mounting Precautions

- (1) You must mount a module using specified mounting holes (Details refer to the drawings).
- (2) You should consider the mounting structure so that uneven force (ex. Twisted stress) is not applied to the module. And the case on which a module is mounted should have sufficient strength so that external force is not transmitted directly to the module.
- (3) Please attach the surface transparent protective plate to the surface in order to protect the polarizer. Transparent protective plate should have sufficient strength in order to resist external force.
- (4) You should adopt radiation structure to satisfy the temperature specification.
- (5) Acetic acid type and chlorine type materials for the cover case are not desirable because the former generates corrosive gas of attacking the polarizer at high temperature and the latter causes circuit break by electro-chemical reaction.
- (6) Do not touch, push or rub the exposed polarizers with glass, tweezers or anything harder than HB pencil lead. And please do not rub with dust clothes with chemical treatment. Do not touch the surface of polarizer for bare hand or greasy cloth. (Some cosmetics are detrimental to the polarizer.)
- (7) When the surface becomes dusty, please wipe gently with absorbent cotton or other soft materials like chamois soaks with petroleum benzene. Normal-hexane is recommended for cleaning the adhesives used to attach front / rear polarizers. Do not use acetone, toluene and alcohol because they cause chemical damage to the polarizer. \* There is no problem of Panel crack under 5kgf /  $\phi$ 10mm
- (8) Wipe off saliva or water drops as soon as possible. Their long time contact with polarizer causes deformations and color fading.
- (9) Do not open the case because inside circuits do not have sufficient strength.

#### 9-2. Operating Precautions

- (1) The spike noise causes the mis-operation of circuits. It should be lower than following voltage :  
 $V = \pm 200\text{mV}$  (Over and under shoot voltage)
- (2) Response time depends on the temperature. (In lower temperature, it becomes longer.)
- (3) Brightness depends on the temperature. (In lower temperature, it becomes lower.)  
 And in lower temperature, response time (required time that brightness is stable after turned on) becomes longer.
- (4) Be careful for condensation at sudden temperature change. Condensation makes damage to polarizer or electrical contacted parts. And after fading condensation, smear or spot will occur.
- (5) When fixed patterns are displayed for a long time, remnant image is likely to occur.
- (6) Module has high frequency circuits. Sufficient suppression to the electromagnetic interference shall be done by system manufacturers. Grounding and shielding methods may be important to minimize the interference.
- (7) Please do not give any mechanical and/or acoustical impact to LCM. Otherwise, LCM can't be operated its full characteristics perfectly.
- (8) A screw which is fastened up the steels should be a machine screw.  
 (if not, it causes metallic foreign material and deal LCM a fatal blow)
- (9) Please do not set LCD on its edge.
- (10) The conductive material and signal cables are kept away from LED driver inductor to prevent abnormal display, sound noise and temperature rising.

### 9-3. Electrostatic Discharge Control

Since a module is composed of electronic circuits, it is not strong to electrostatic discharge. Make certain that treatment persons are connected to ground through wrist band etc. And don't touch interface pin directly.

### 9-4. Precautions for Strong Light Exposure

Strong light exposure causes degradation of polarizer and color filter.

### 9-5. Storage

When storing modules as spares for a long time, the following precautions are necessary.

- (1) Store them in a dark place. Do not expose the module to sunlight or fluorescent light. Keep the temperature between 5°C and 35°C at normal humidity.
- (2) The polarizer surface should not come in contact with any other object.  
It is recommended that they be stored in the container in which they were shipped.
- (3) Storage condition is guaranteed under packing conditions.
- (4) The phase transition of Liquid Crystal in the condition of the low or high storage temperature will be recovered when the LCD module returns to the normal condition

### 9-6. Handling Precautions for Protection Film

- (1) The protection film is attached to the bezel with a small masking tape.  
When the protection film is peeled off, static electricity is generated between the film and polarizer.  
This should be peeled off slowly and carefully by people who are electrically grounded and with well ion-blown equipment or in such a condition, etc.
- (2) When the module with protection film attached is stored for a long time, sometimes there remains a very small amount of glue still on the bezel after the protection film is peeled off.
- (3) You can remove the glue easily. When the glue remains on the bezel surface or its vestige is recognized, please wipe them off with absorbent cotton waste or other soft material like chamois soaked with normal-hexane.

Product Specification

# APPENDIX- I

■ Pallet Ass'y

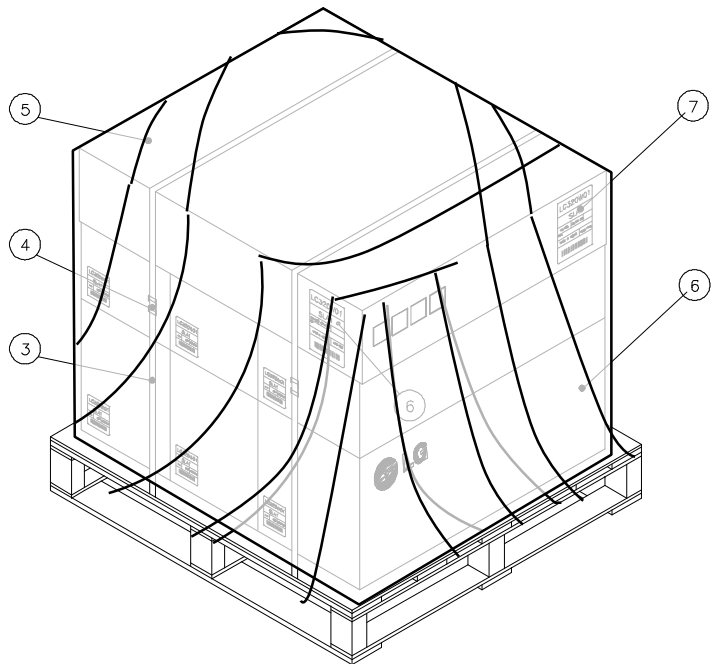
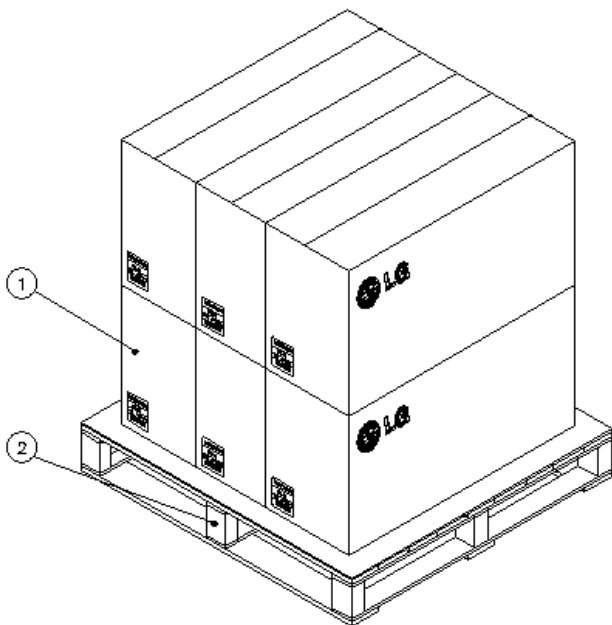

NO.	DESCRIPTION	MATERIAL
1	PACKING ASS'Y	
2	PALLET	Plywood
3	BAND	PP
4	CLIP, BAND	STEEL
5	Angle Cover	PAPER
6	WRAP	LDPE
7	LABEL	ART 100X70

Product Specification

■ Packing Ass'y

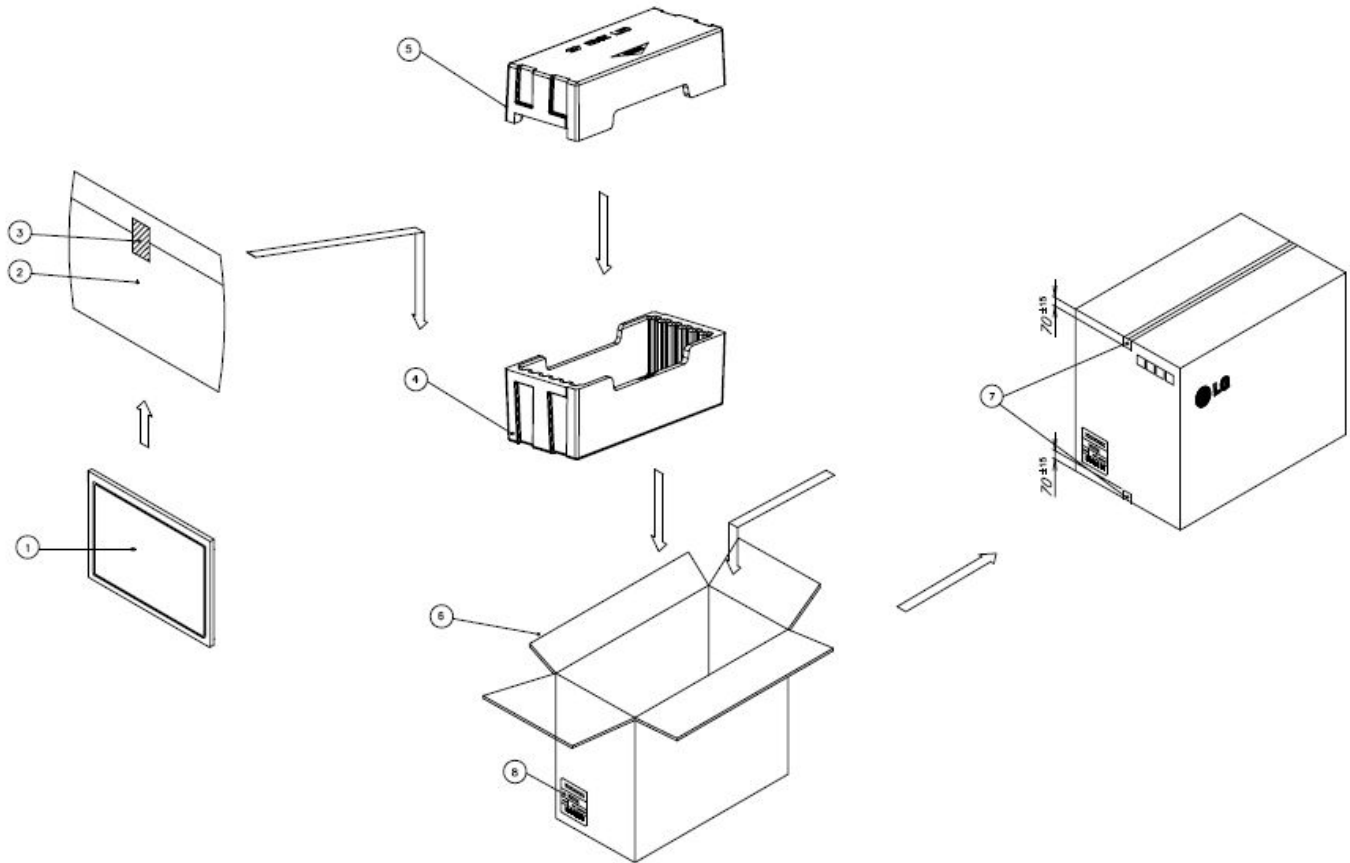

NO.	DESCRIPTION	MATERIAL
1	LCD Module	
2	BAG	AL
3	TAPE	MASKING 20MMX50M
4	Packing,Bottom	EPS
5	Packing,Top	EPS
6	BOX	PAPER_DW3
7	TAPE	OPP 70MMX300M
8	Label	ART 100X70



Product Specification

# APPENDIX- II-1

■ LCM Label



Product Specification

# APPENDIX- II-2

■ Pallet Label

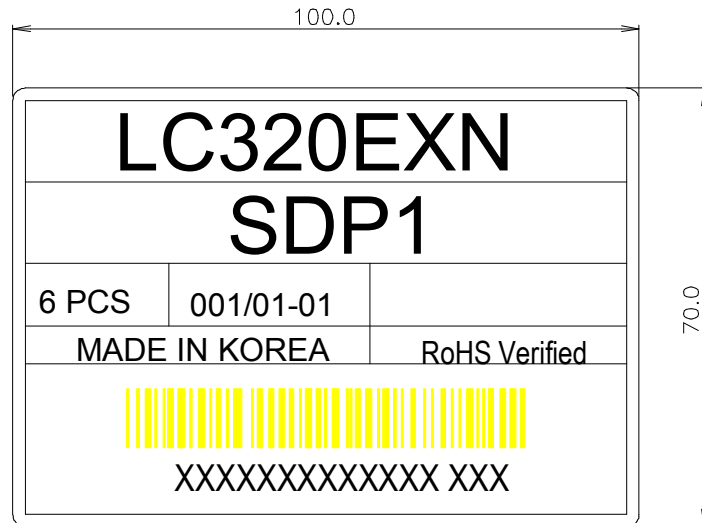

## # APPENDIX-III-1

## ■ Required signal assignment for Flat Link Transmitter(Pin9="L" or NC)

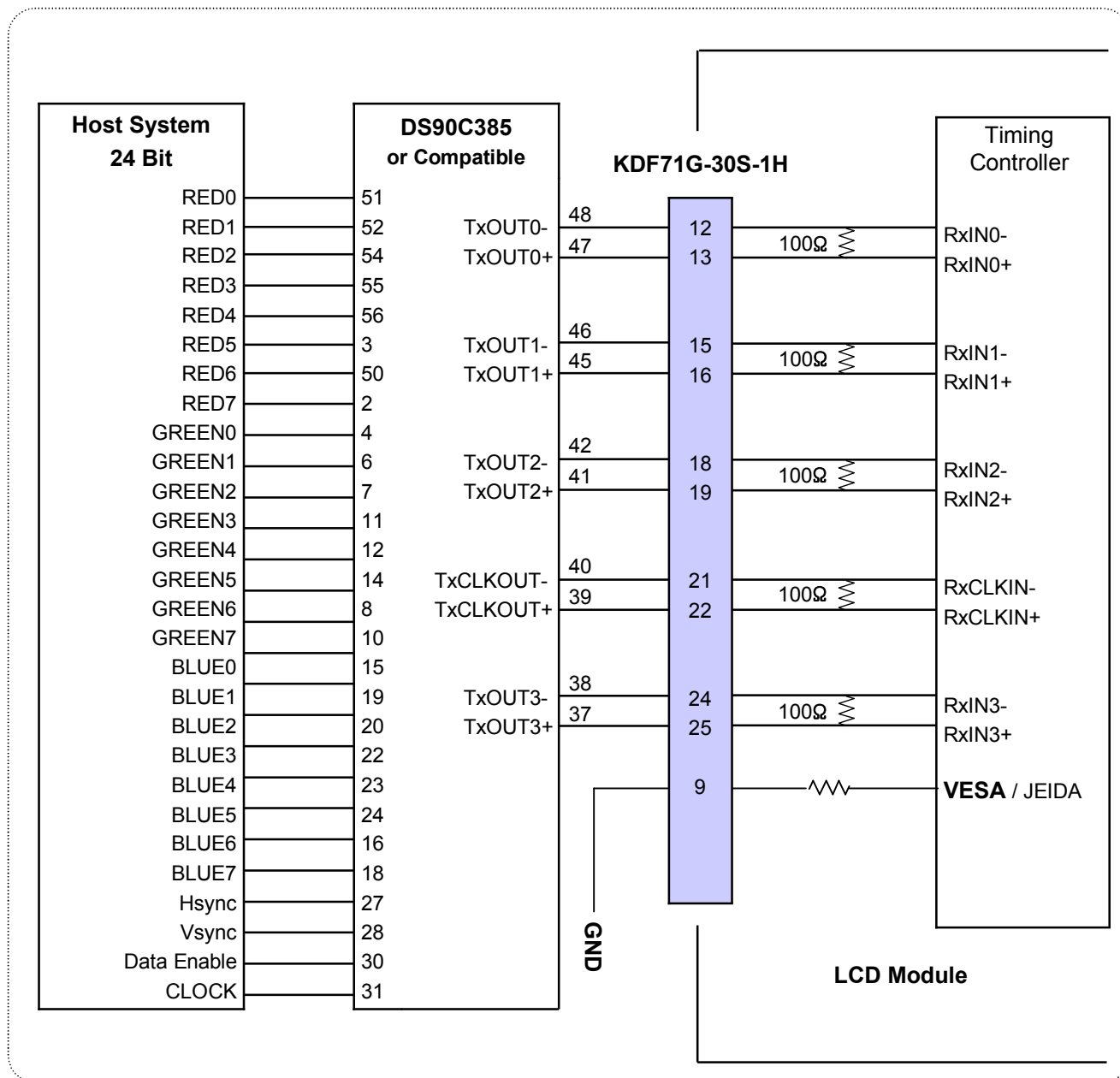

## Notes:

1. The LCD module uses a 100 Ohm( $\Omega$ ) resistor between positive and negative lines of each receiver input.
2. Refer to LVDS transmitter data sheet for detail descriptions. (DS90C385 or Compatible)
3. '7' means MSB and '0' means LSB at R,G,B pixel data.

Product Specification

# APPENDIX-III-2

Required signal assignment for Flat Link Transmitter(Pin9="H")

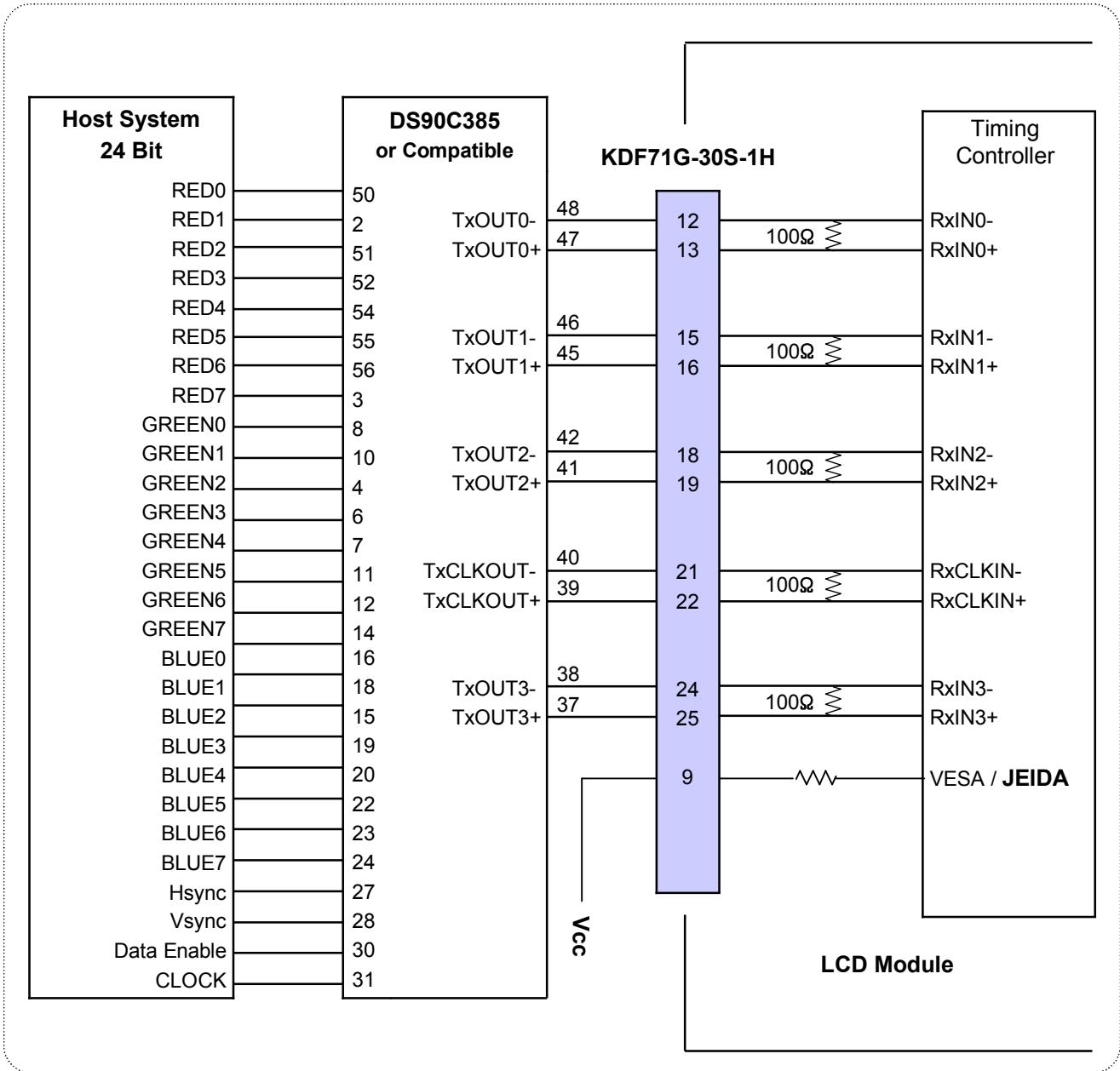

Notes:

1. The LCD module uses a 100 Ohm(Ω) resistor between positive and negative lines of each receiver input.
2. Refer to LVDS transmitter data sheet for detail descriptions. (DS90C385 or Compatible)
3. '7' means MSB and '0' means LSB at R,G,B pixel data.

# APPENDIX- IV

### LVDS Data-Mapping info. (8bit)

■ LVDS Select : “H” Data-Mapping (JEIDA format)

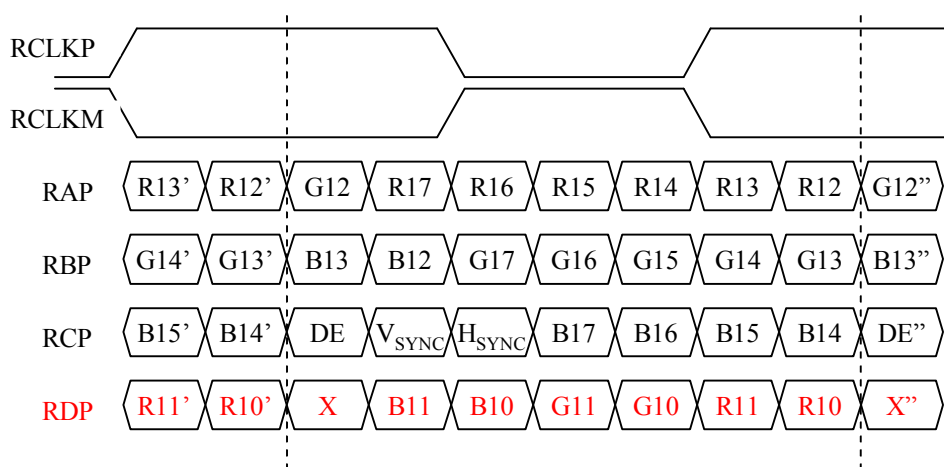

■ LVDS Select : “L” Data-Mapping (VESA format)

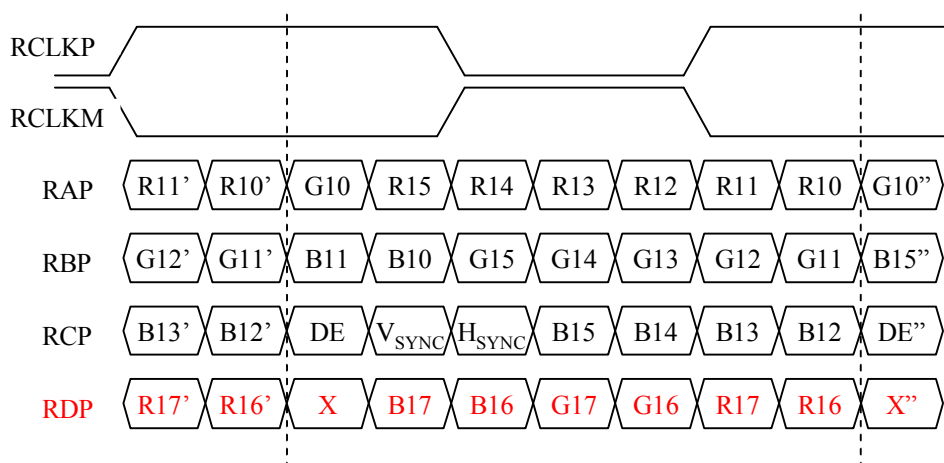

## # APPENDIX- V

**Option Pin Circuit Block Diagram**

Circuit Block Diagram of LVDS Format Selection pin

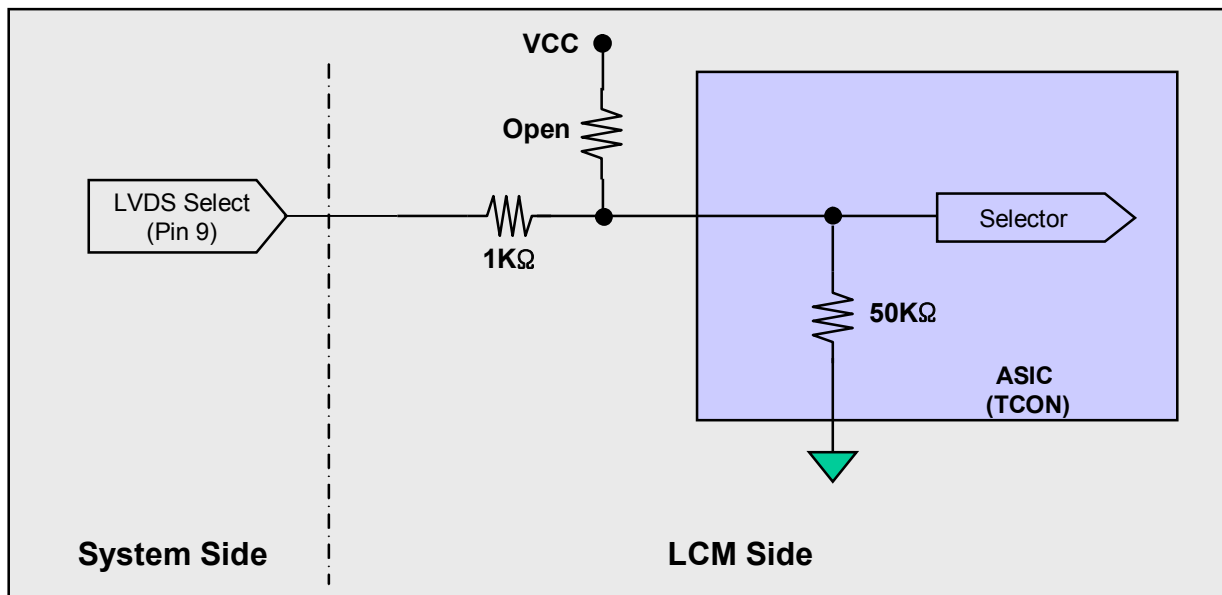

## # APPENDIX- VI

## ■ Drop Test [ Packing Condition]

Direction	Transportation
Drop Height	30cm
Number of Drop	2

- Note : 1. Before and after test, LCM should be operated with normal function.  
2. Product reliability of Drop had been verified, so there are not any test in LG Display.

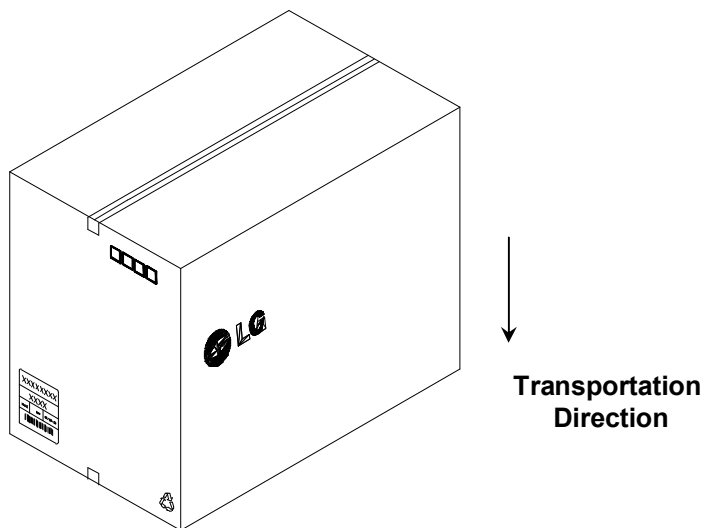

Product Specification

# APPENDIX- VII

■ Standard specification of Eyeglasses

This is recommended data of Eyeglasses for LC320EXN-SDP1 model. (details refer to table)

For each item, depending on the eyeglass manufacturer tolerances may occur, this tolerance can affect 3D performance. (3D Crosstalk, 3D luminance, 3D viewing angle)

<Table. Standard specification of Eyeglasses>

Design item of Eyeglasses		Left	Right	Remark
Optical axis	a) Slow axis of retarder	-45°	45°	Refer to drawing
	b) Transmission axis of polarizer	0°	0°	
Retardation value	Retarder	125nm		@550nm

※ Recommended polarizer  
Polarization efficiency: more than 99.90%

