

Product Specification

# SPECIFICATION FOR APPROVAL

- ( ● ) Preliminary Specification
- (   ) Final Specification

|       |                    |
|-------|--------------------|
| Title | 32.0" WXGA TFT LCD |
|-------|--------------------|

|       |  |
|-------|--|
| BUYER |  |
| MODEL |  |

|          |                          |
|----------|--------------------------|
| SUPPLIER | LG.Philips LCD Co., Ltd. |
| *MODEL   | LC320W01                 |
| SUFFIX   | SL13                     |

\*When you obtain standard approval, please use the above model name without suffix

| APPROVED BY | SIGNATURE DATE |
|-------------|----------------|
| /           | _____          |
| /           | _____          |
| /           | _____          |

Please return 1 copy for your confirmation with your signature and comments.

| APPROVED BY              | SIGNATURE DATE |
|--------------------------|----------------|
| J.H Lee / Senior Manager | _____          |
| <b>REVIEWED BY</b>       |                |
| H.S Song / Manager       | _____          |
| <b>PREPARED BY</b>       |                |
| D.E Kim / Engineer       | _____          |

**TV Product Development Dept.  
LG. Philips LCD Co., Ltd**

Product Specification

**CONTENTS**

| Number | ITEM                                     | Page |
|--------|--|------|
|        | COVER                                    | 1    |
|        | CONTENTS                                 | 2    |
|        | RECORD OF REVISIONS                      | 3    |
| 1      | GENERAL DESCRIPTION                      | 4    |
| 2      | ABSOLUTE MAXIMUM RATINGS                 | 5    |
| 3      | ELECTRICAL SPECIFICATIONS                | 6    |
| 3-1    | ELECTRICAL CHARACTERISTICS               | 6    |
| 3-2    | INTERFACE CONNECTIONS                    | 8    |
| 3-3    | SIGNAL TIMING SPECIFICATIONS             | 12   |
| 3-4    | SIGNAL TIMING WAVEFORMS                  | 13   |
| 3-5    | COLOR INPUT DATA REFERENCE               | 14   |
| 3-6    | POWER SEQUENCE                           | 15   |
| 4      | OPTICAL SPECIFICATIONS                   | 17   |
| 5      | MECHANICAL CHARACTERISTICS               | 21   |
| 6      | RELIABILITY                              | 24   |
| 7      | INTERNATIONAL STANDARDS                  | 25   |
| 7-1    | SAFETY                                   | 25   |
| 7-2    | EMC                                      | 25   |
| 8      | PACKING                                  | 26   |
| 8-1    | DESIGNATION OF LOT MARK                  | 26   |
| 8-2    | PACKING FORM                             | 26   |
| 9      | PRECAUTIONS                              | 27   |
| 9-1    | MOUNTING PRECAUTIONS                     | 27   |
| 9-2    | OPERATING PRECAUTIONS                    | 27   |
| 9-3    | ELECTROSTATIC DISCHARGE CONTROL          | 28   |
| 9-4    | PRECAUTIONS FOR STRONG LIGHT EXPOSURE    | 28   |
| 9-5    | STORAGE                                  | 28   |
| 9-6    | HANDLING PRECAUTIONS FOR PROTECTION FILM | 28   |



Product Specification

### 1. General Description

The LC320W01 is a Color Active Matrix Liquid Crystal Display with an integral External Electrode Fluorescent Lamp(EEFL) backlight system. The matrix employs a-Si Thin Film Transistor as the active element. It is a transmissive type display operating in the normally black mode. It has a 31.51 inch diagonally measured active display area with WXGA resolution (768 vertical by 1366 horizontal pixel array). Each pixel is divided into Red, Green and Blue sub-pixels or dots which are arranged in vertical stripes. Gray scale or the luminance of the sub-pixel color is determined with a 8-bit gray scale signal for each dot, thus presenting a palette of more than 16.7M(true) colors.

It has been designed to apply the 8-bit 1-port LVDS interface.

It is intended to support LCD TV, PCTV where high brightness, super wide viewing angle, high color gamut, high color depth and fast response time are important.

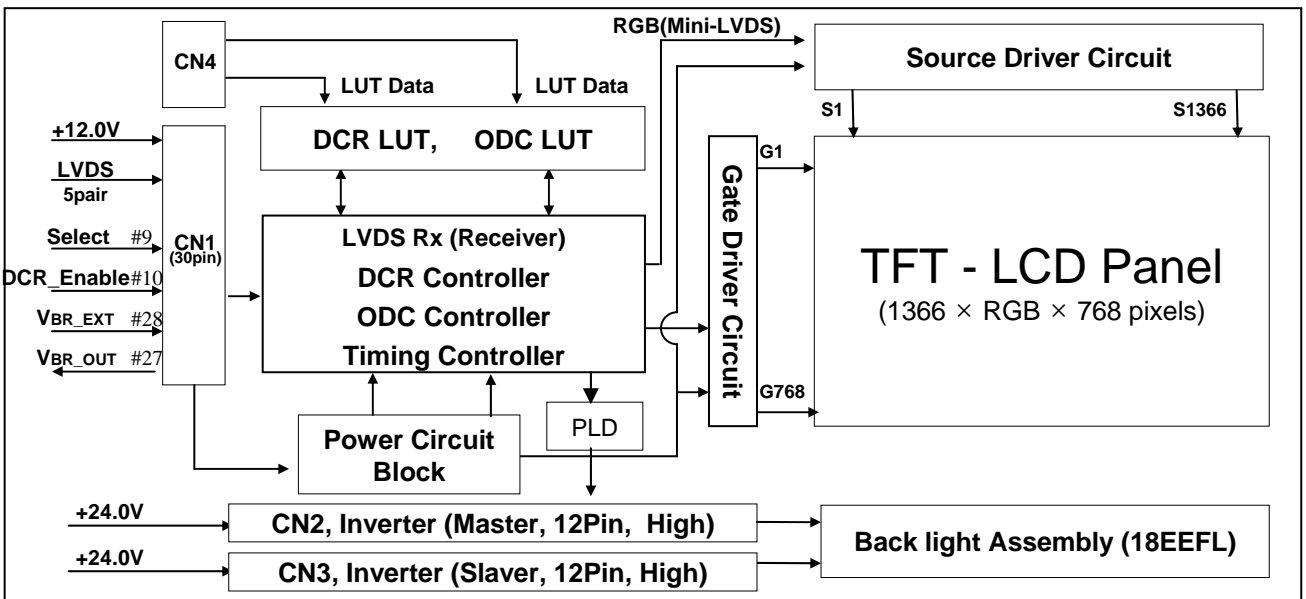

### General Features

|                        |  |
|------------------------|--|
| Active Screen Size     | 31.51 inches(800.4mm) diagonal   |
| Outline Dimension      | 760.0 mm(H) x 450.0 mm(V) x 48.0 mm(D) (Typ.)                          |
| Pixel Pitch            | 170.25 $\mu$ m x 510.75 $\mu$ m x RGB                                  |
| Pixel Format           | 1366 horiz. by 768 vert. pixels RGB stripe arrangement                 |
| Color Depth            | 8bit, 16,7 M colors  |
| Luminance, White       | 500 cd/m <sup>2</sup> (Center 1 point) (Typ.)                          |
| Dynamic C/R (for AI)   | 1200:1 (Typ.)  |
| Viewing Angle (CR>10)  | Viewing angle free ( R/L 178(Typ.), U/D 178(Typ.))                     |
| Power Consumption      | Total 89.4Watt (Typ.) (Logic=5.4 W, Lamp=84W [I <sub>BL</sub> =90mA] ) |
| Weight                 | 6,900 g (Typ.)   |
| Display Operating Mode | Transmissive mode, normally black                                      |
| Surface Treatment      | Hard coating(3H), anti-glare treatment of the front polarizer          |

Product Specification

2. Absolute Maximum Ratings

The following items are maximum values which, if exceeded, may cause faulty operation or damage to the LCD module.

Table 1. ABSOLUTE MAXIMUM RATINGS

| Parameter                  |                    | Symbol              | Value |       | Unit            | Remark       |
|----------------------------|--------------------|---------------------|-------|-------|-----------------|--------------|
|                            |                    |                     | Min   | Max   |                 |              |
| Power Input Voltage        | LCM                | V <sub>LCD</sub>    | -0.3  | +14.0 | V <sub>DC</sub> | at 25 ± 2 °C |
|                            | Backlight inverter | V <sub>BL</sub>     | 21.6  | +27.0 | V <sub>DC</sub> |              |
| ON/OFF Control Voltage     |                    | V <sub>ON/OFF</sub> | -0.3  | +5.25 | V <sub>DC</sub> |              |
| Brightness Control Voltage |                    | V <sub>Br</sub>     | 0     | +5.0  | V <sub>DC</sub> |              |
| Operating Temperature      |                    | T <sub>OP</sub>     | 0     | +40   | °C              | Note 1,2     |
| Storage Temperature        |                    | T <sub>ST</sub>     | -20   | +50   | °C              |              |
| Operating Ambient Humidity |                    | H <sub>OP</sub>     | 10    | 90    | %RH             |              |
| Storage Humidity           |                    | H <sub>ST</sub>     | 10    | 90    | %RH             |              |

Note 1. Temperature and relative humidity range are shown in the figure below.  
Wet bulb temperature should be 39 °C Max, and no condensation of water.  
2. Ambient illuminance should be more than 10 lux.

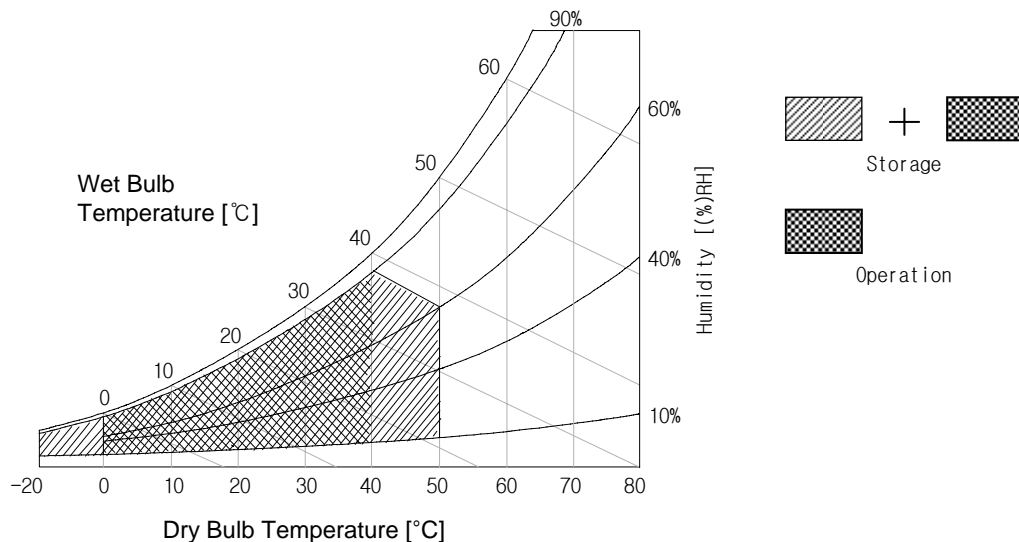

Temperature and relative humidity

Product Specification

### 3. Electrical Specifications

#### 3-1. Electrical Characteristics

It requires two power inputs. One is employed to power for the LCD circuit. The other input power for the EEFL/Backlight is to power inverter.

**Table 2-1. ELECTRICAL CHARACTERISTICS**

| Parameter                        | Symbol            | Value |      |      | Unit              | Note |
|----------------------------------|-------------------|-------|------|------|-------------------|------|
|                                  |                   | Min   | Typ  | Max  |                   |      |
| MODULE :                         |                   |       |      |      |                   |      |
| Power Input Voltage              | V <sub>LCD</sub>  | 11.4  | 12.0 | 12.6 | V <sub>DC</sub>   |      |
| Permissible Input Ripple Voltage | V <sub>RP</sub>   | -     | -    | 200  | mV <sub>P-P</sub> |      |
| Power Input Current              | I <sub>LCD</sub>  | -     | 450  | 580  | mA                | 1    |
|                                  |                   | -     | 570  | 740  | mA                | 2    |
| Power Consumption                | P <sub>LCD</sub>  | -     | 5.4  | 7.0  | Watt              | 1    |
| Rush current                     | I <sub>RUSH</sub> | -     | -    | 3.0  | A                 | 3    |

- Notes :
1. The specified current and power consumption are under the  $V_{LCD}=12.0V$ ,  $25 \pm 2^{\circ}C$ ,  $f_V=60Hz$  condition whereas mosaic pattern(8 x 6) is displayed and  $f_V$  is the frame frequency.
  2. The current is specified at the maximum current pattern.
  3. The duration of rush current is about 2ms and rising time of power input is 1ms (min.).

White : 255Gray  
 Black : 0Gray

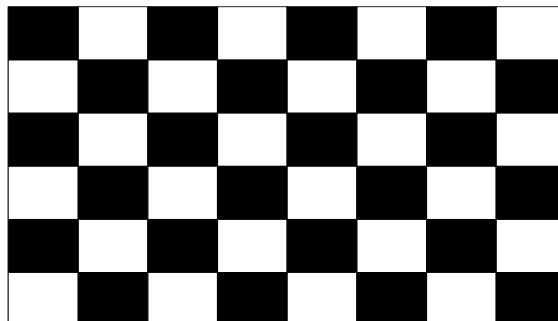

Mosaic Pattern(8 x 6)

Product Specification

**Table 2-2. ELECTRICAL CHARACTERISTICS**

| Parameter                                |                   | Symbol          | Value            |        |      | Unit            | Note            |  |
|--|-------------------|-----------------|------------------|--------|------|-----------------|-----------------|--|
|  |                   |                 | Min              | Typ    | Max  |                 |                 |  |
| Inverter :                               |                   |                 |                  |        |      |                 |                 |  |
| Power Input Voltage                      |                   | V <sub>BL</sub> | 22.8             | 24.0   | 25.2 | V <sub>DC</sub> | 1               |  |
| Power Input Current                      |                   | I <sub>BL</sub> | -                | 3.5    | 3.85 | A               | 1               |  |
| Power Consumption                        |                   | P <sub>BL</sub> | -                | 84     | 92.4 | W               | 1               |  |
| Input Voltage for Control System Signals | Brightness Adjust | V <sub>BR</sub> | 0                |        | 3.3  | V <sub>DC</sub> | 2               |  |
|  | On/Off            | On              | V <sub>on</sub>  | 3.0    | 5.0  | 5.25            | V <sub>DC</sub> |  |
|  |                   | Off             | V <sub>off</sub> | -0.3   | 0    | 0.8             | V <sub>DC</sub> |  |
| Lamp :                                   |                   |                 |                  |        |      |                 |                 |  |
| Life Time                                | 25±2 °C           |                 | 50,000           | 60,000 |      | Hrs             | 3               |  |

Note : 1. The specified current and power consumption are under the typical supply Input voltage, 24.0V.  
Ripple voltage of the Power Input Voltage is under 0.2 Vp-p.

2. Brightness Control.

This V<sub>BR</sub> Voltage control brightness.

| V <sub>BR</sub> Voltage | Function                  |
|-------------------------|---------------------------|
| 3.3V                    | Maximum Brightness (100%) |
| 0V                      | Minimum Brightness.(30%)  |

3. Specified values are for a single lamp which is aligned horizontally.

The Life Time is determined as the time at which brightness of the lamp is 50% compared to that of initial value at the typical lamp current on condition of continuous operating at each ambient temperature.

Product Specification

### 3-2. Interface Connections

This LCD module employs two kinds of interface connection, a 30-pin connector is used for the module electronics and two 12-pin connectors are used for the integral backlight system.

#### 3-2-1. LCD Module

- LCD Connector(CN1) : FI-X30SSL-HF (Manufactured by JAE) or Equivalent
- Mating Connector : FI-30C2L (Manufactured by JAE) or Equivalent

**Table 3. MODULE CONNECTOR(CN1) PIN CONFIGURATION**

| Pin No. | Symbol     | Description  | Note    |
|---------|------------|--|---------|
| 1       | VLCD       | Power Supply +12.0V                                    |         |
| 2       | VLCD       | Power Supply +12.0V                                    |         |
| 3       | VLCD       | Power Supply +12.0V                                    |         |
| 4       | VLCD       | Power Supply +12.0V                                    |         |
| 5       | GND        | Ground   |         |
| 6       | GND        | Ground   |         |
| 7       | GND        | Ground   |         |
| 8       | GND        | Ground   |         |
| 9       | Select     | Select LVDS Data format                                | 1       |
| 10      | DCR Enable | Dynamic CR Enable ( 'GND'= Disable , '3.3V' = Enable ) | Page.29 |
| 11      | GND        | Ground   |         |
| 12      | RA-        | LVDS Receiver Signal(-)                                |         |
| 13      | RA+        | LVDS Receiver Signal(+)                                |         |
| 14      | GND        | Ground   |         |
| 15      | RB-        | LVDS Receiver Signal(-)                                |         |
| 16      | RB+        | LVDS Receiver Signal(+)                                |         |
| 17      | GND        | Ground   |         |
| 18      | RC-        | LVDS Receiver Signal(-)                                |         |
| 19      | RC+        | LVDS Receiver Signal(+)                                |         |
| 20      | GND        | Ground   |         |
| 21      | RCLK-      | LVDS Receiver Clock Signal(-)                          |         |
| 22      | RCLK+      | LVDS Receiver Clock Signal(+)                          |         |
| 23      | GND        | Ground   |         |
| 24      | RD-        | LVDS Receiver Signal(-)                                |         |
| 25      | RD+        | LVDS Receiver Signal(+)                                |         |
| 26      | GND        | Ground   |         |
| 27      | VBR_OUT    | VBR output form LCD module                             |         |
| 28      | VBR_EXT    | External VBR input from System to LCD module           |         |
| 29      | GND        | Ground   |         |
| 30      | GND        | Ground   | 2       |

Note: 1. If the pin no. 9 is Ground, Interface format is "LG", and if the pin no. 9 is Vcc(3.3V), Interface format is "DISM". See page 9 and 10.

2. The pin no. 30 is necessary for LCD test.

When LVDS signals are abnormal operation more than 3-Vsync times and power 12V is supplied,

'Open' or 'Vcc' : LCD operate itself some test patterns.(AGP – Auto Generation Pattern)

'Ground' : LCD operate itself a black pattern. (NSB – No Signal Black)

LPL recommend 'Ground' for NSB.

4. All GND (ground) pins should be connected together, which should be also connected to the LCD module's metal frame.

5. All VLCD (power input) pins should be connected together.

6. Input Levels of LVDS signals are based on the IEA 664 Standard.



Product Specification

Table 4. REQUIRED SIGNAL ASSIGNMENT FOR LVDS TRANSMITTER ( Pin9="L" or "Open" )

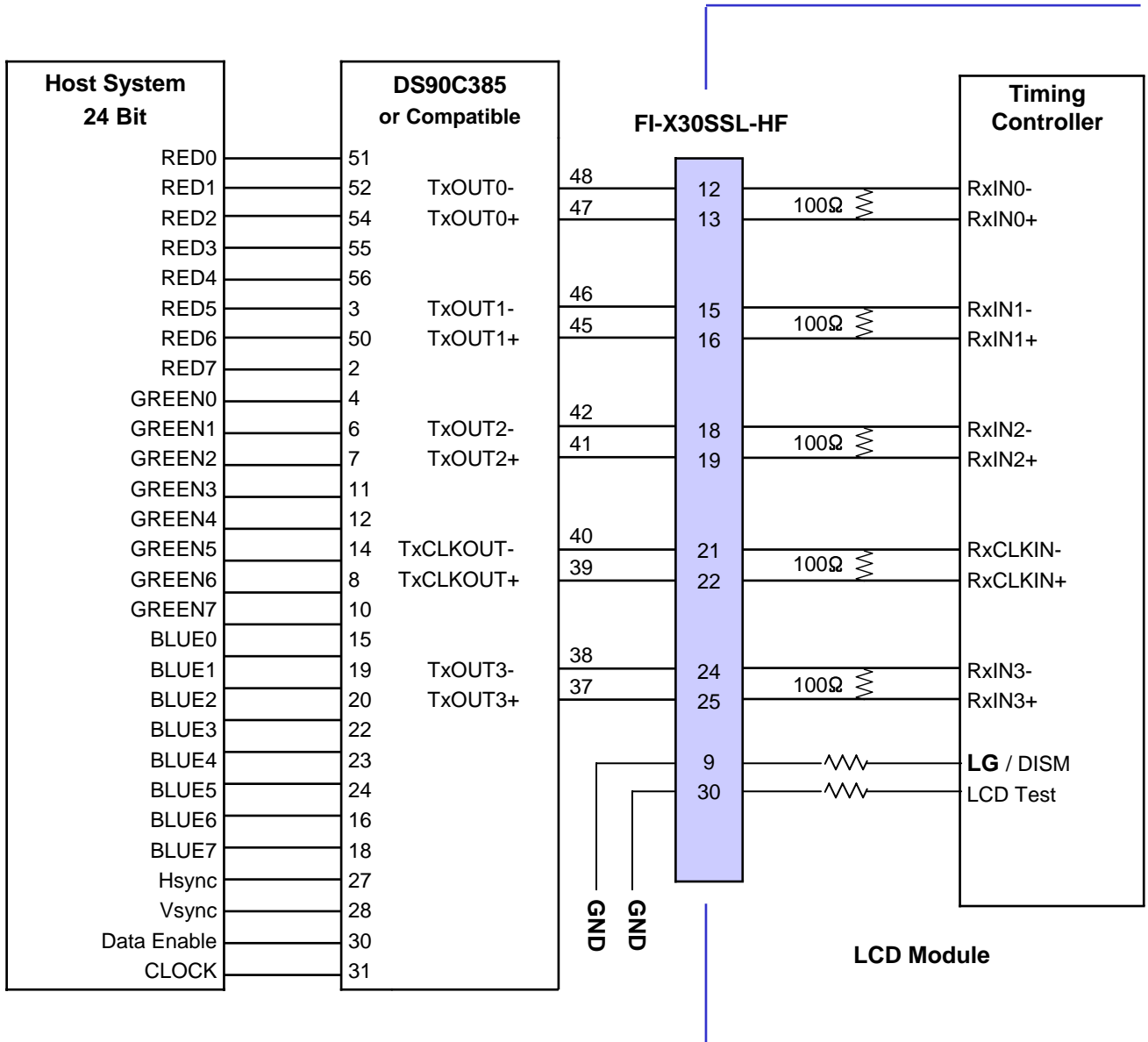

- Note: 1. The LCD Module uses a 100 Ohm [Ω] resistor between positive and negative lines of each receiver input.  
 2. Refer to LVDS Transmitter Data Sheet for detail descriptions. (DS90C385 or Compatible)  
 3. '7' means MSB and '0' means LSB at R,G,B pixel data.



Product Specification

**3-2-2. Backlight Inverter**

Input Connector

-Inverter Connector : S12B-PHA-SM3(manufactured by JST) or Equivalent

-Mating Connector : PHR-12 or Equivalent

Status Connector

-Inverter Connector : S2B-PH-SM3-TB(manufactured by JST) or Equivalent

-Mating Connector : PHR-2(manufactured by JST) or Equivalent

**Table 6. INVERTER CONNECTOR PIN CONFIGURATION**

| Pin No                                 | Symbol | Description                                 | Master | Slave      | Note |
|--|--------|---|--------|------------|------|
| 1                                      | VBL    | Power Supply +24.0V                         | VBL    | VBL        |      |
| 2                                      | VBL    | Power Supply +24.0V                         | VBL    | VBL        |      |
| 3                                      | VBL    | Power Supply +24.0V                         | VBL    | VBL        |      |
| 4                                      | VBL    | Power Supply +24.0V                         | VBL    | VBL        |      |
| 5                                      | VBL    | Power Supply +24.0V                         | VBL    | VBL        |      |
| 6                                      | GND    | POWER GND                                   | GND    | GND        |      |
| 7                                      | GND    | POWER GND                                   | GND    | GND        |      |
| 8                                      | GND    | POWER GND                                   | GND    | GND        | 1    |
| 9                                      | GND    | POWER GND                                   | GND    | GND        |      |
| 10                                     | GND    | POWER GND                                   | GND    | GND        |      |
| 11                                     | VBR    | 0V ~ 3.3V                                   | VBR    | Don't care | 2    |
| 12                                     | On/Off | 0V ~ 5.0V                                   | On/Off | Don't care | 3    |
| Option Pin(Lamp Open Status Detection) |        |   |        |            |      |
| 1                                      | GND    | POWER GND                                   | GND    |            |      |
| 2                                      | Status | Upper 3.0V(Normal),<br>Under 0.7V(Abnormal) | Status |            |      |

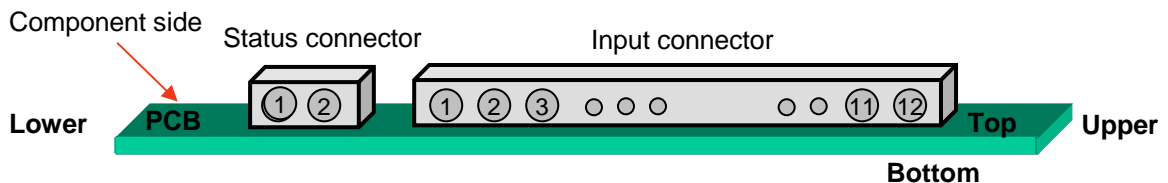

Note : 1. GND should be connected to the LCD module's metal frame.

2. Minimum Brightness : VBR = 0.0V  
Maximum Brightness : VBR = 3.3V

3. VON : 3.0 ~ 5.0V  
VOFF : -0.3 ~ 0.8V

## Product Specification

### 3-3. Signal Timing Specifications

This is the signal timing required at the input of the LVDS transmitter. All of the interface signal timing should be satisfied with the following specification for its proper operation.

**Table 7. TIMING TABLE**

| ITEM                | Symbol                 |      | Min      | Typ  | Max      | Unit | Remark                                     |
|---------------------|------------------------|------|----------|------|----------|------|--|
| DCLK                | Period                 | tCLK | 12.5     | 13.8 | 14.7     | ns   |  |
|                     | Frequency              | -    | 68       | 72.3 | 80       | MHz  |  |
| Hsync               | Period                 | tHP  | 1456     | 1528 | 1776     | tCLK |  |
|                     | Frequency              | fH   | 45       | 47.4 | 50       | KHz  |  |
|                     | Width                  | tWH  | 8        | 32   | -        | tCLK |  |
| Vsync               | Period                 | tVP  | 775      | 790  | 1063     | tHP  | Note 1)<br>PAL : 47~53Hz<br>NTSC : 57~63Hz |
|                     | Frequency              | fV   | 47       | 60   | 63       | Hz   |  |
|                     | Width                  | tWV  | 2        | 5    | -        | tHP  |  |
| DE<br>(Data Enable) | Horizontal Valid       | tHV  | 1366     | 1366 | 1366     | tCLK |  |
|                     | Horizontal Back Porch  | tHBP | 24       | 80   | -        |      |  |
|                     | Horizontal Front Porch | tHFP | 24       | 48   | -        |      |  |
|                     | Horizontal Blank       | -    | tHP- tHV | 162  | tHP- tHV | tHP  |  |
|                     | Vertical Valid         | tVV  | 768      | 768  | 768      |      |  |
|                     | Vertical Back Porch    | tVBP | 4        | 15   | -        |      |  |
|                     | Vertical Front Porch   | tVFP | 1        | 2    | -        |      |  |
|                     | Vertical Blank         | -    | tVP- tVV | 22   | tVP- tVV |      |  |

Note : Hsync Period and Hsync Width should be even number times of tCLK. If the value is odd number times of tCLK, display control signal can be asynchronous. In order to operate the LCD, Hsync, Vsync and DE(Data Enable) signals should be used.

1. The performance of the electro-optical characteristics may be influenced by variance of the vertical refresh rate.
2. Vsync and Hsync should be keep the above specification.
3. Timing should be set based on clock frequency.

Product Specification

3-4. Signal Timing Waveforms

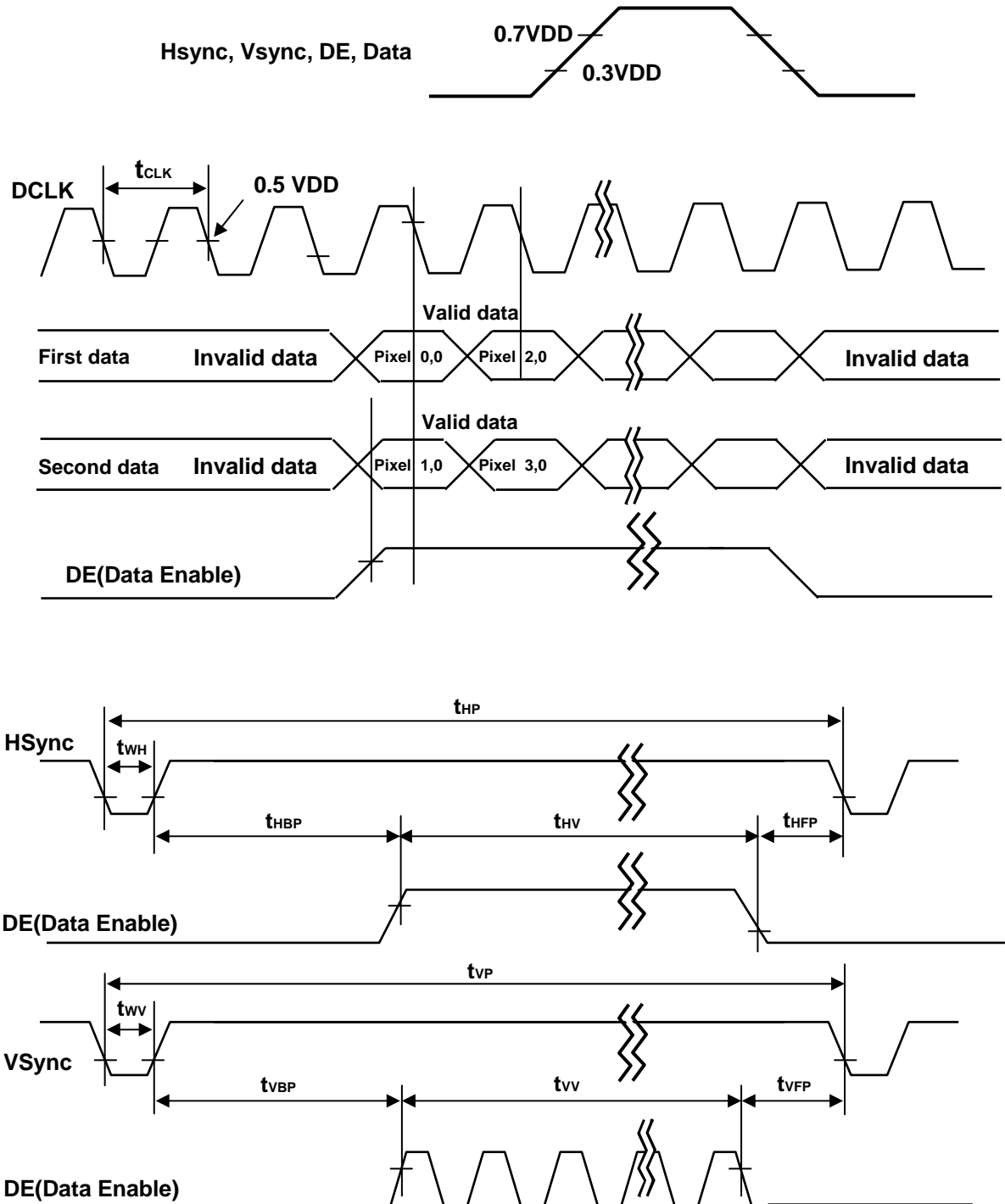

Product Specification

### 3-5. Color Data Reference

The brightness of each primary color(red,green,blue) is based on the 8-bit gray scale data input for the color the higher the binary input, the brighter the color. The below table provides a reference for color versus data input.

**Table 8. COLOR DATA REFERENCE**

| Color       |                  | Input Color Data |     |     |     |     |     |     |     |       |     |     |     |     |     |     |     |      |     |     |     |     |     |     |     |
|-------------|------------------|------------------|-----|-----|-----|-----|-----|-----|-----|-------|-----|-----|-----|-----|-----|-----|-----|------|-----|-----|-----|-----|-----|-----|-----|
|             |                  | RED              |     |     |     |     |     |     |     | GREEN |     |     |     |     |     |     |     | BLUE |     |     |     |     |     |     |     |
|             |                  | MSB              | MSB | MSB | MSB | MSB | MSB | MSB | MSB | LSB   | LSB | LSB | LSB | LSB | LSB | LSB | LSB | LSB  | LSB | LSB | LSB | LSB | LSB | LSB | LSB |
| R7          | R6               | R5               | R4  | R3  | R2  | R1  | R0  | G7  | G6  | G5    | G4  | G3  | G2  | G1  | G0  | B7  | B6  | B5   | B4  | B3  | B2  | B1  | B0  |     |     |
| Basic Color | Black            | 0                | 0   | 0   | 0   | 0   | 0   | 0   | 0   | 0     | 0   | 0   | 0   | 0   | 0   | 0   | 0   | 0    | 0   | 0   | 0   | 0   | 0   | 0   | 0   |
|             | Red (255)        | 1                | 1   | 1   | 1   | 1   | 1   | 1   | 1   | 0     | 0   | 0   | 0   | 0   | 0   | 0   | 0   | 0    | 0   | 0   | 0   | 0   | 0   | 0   | 0   |
|             | Green (255)      | 0                | 0   | 0   | 0   | 0   | 0   | 0   | 0   | 1     | 1   | 1   | 1   | 1   | 1   | 1   | 1   | 0    | 0   | 0   | 0   | 0   | 0   | 0   | 0   |
|             | Blue (255)       | 0                | 0   | 0   | 0   | 0   | 0   | 0   | 0   | 0     | 0   | 0   | 0   | 0   | 0   | 0   | 0   | 1    | 1   | 1   | 1   | 1   | 1   | 1   | 1   |
|             | Cyan             | 0                | 0   | 0   | 0   | 0   | 0   | 0   | 0   | 1     | 1   | 1   | 1   | 1   | 1   | 1   | 1   | 1    | 1   | 1   | 1   | 1   | 1   | 1   | 1   |
|             | Magenta          | 1                | 1   | 1   | 1   | 1   | 1   | 1   | 1   | 0     | 0   | 0   | 0   | 0   | 0   | 0   | 0   | 1    | 1   | 1   | 1   | 1   | 1   | 1   | 1   |
|             | Yellow           | 1                | 1   | 1   | 1   | 1   | 1   | 1   | 1   | 1     | 1   | 1   | 1   | 1   | 1   | 1   | 1   | 0    | 0   | 0   | 0   | 0   | 0   | 0   | 0   |
|             | White            | 1                | 1   | 1   | 1   | 1   | 1   | 1   | 1   | 1     | 1   | 1   | 1   | 1   | 1   | 1   | 1   | 1    | 1   | 1   | 1   | 1   | 1   | 1   | 1   |
| RED         | RED (000) Dark   | 0                | 0   | 0   | 0   | 0   | 0   | 0   | 0   | 0     | 0   | 0   | 0   | 0   | 0   | 0   | 0   | 0    | 0   | 0   | 0   | 0   | 0   | 0   | 0   |
|             | RED (001)        | 0                | 0   | 0   | 0   | 0   | 0   | 0   | 1   | 0     | 0   | 0   | 0   | 0   | 0   | 0   | 0   | 0    | 0   | 0   | 0   | 0   | 0   | 0   | 0   |
|             | ...              | ...              |     |     |     |     |     |     |     | ...   |     |     |     |     |     |     |     | ...  |     |     |     |     |     |     |     |
|             | RED (254)        | 1                | 1   | 1   | 1   | 1   | 1   | 1   | 0   | 0     | 0   | 0   | 0   | 0   | 0   | 0   | 0   | 0    | 0   | 0   | 0   | 0   | 0   | 0   | 0   |
|             | RED (255)        | 1                | 1   | 1   | 1   | 1   | 1   | 1   | 1   | 0     | 0   | 0   | 0   | 0   | 0   | 0   | 0   | 0    | 0   | 0   | 0   | 0   | 0   | 0   | 0   |
| GREEN       | GREEN (000) Dark | 0                | 0   | 0   | 0   | 0   | 0   | 0   | 0   | 0     | 0   | 0   | 0   | 0   | 0   | 0   | 0   | 0    | 0   | 0   | 0   | 0   | 0   | 0   | 0   |
|             | GREEN (001)      | 0                | 0   | 0   | 0   | 0   | 0   | 0   | 0   | 0     | 0   | 0   | 0   | 0   | 0   | 0   | 1   | 0    | 0   | 0   | 0   | 0   | 0   | 0   | 0   |
|             | ...              | ...              |     |     |     |     |     |     |     | ...   |     |     |     |     |     |     |     | ...  |     |     |     |     |     |     |     |
|             | GREEN (254)      | 0                | 0   | 0   | 0   | 0   | 0   | 0   | 0   | 1     | 1   | 1   | 1   | 1   | 1   | 1   | 0   | 0    | 0   | 0   | 0   | 0   | 0   | 0   | 0   |
|             | GREEN (255)      | 0                | 0   | 0   | 0   | 0   | 0   | 0   | 0   | 1     | 1   | 1   | 1   | 1   | 1   | 1   | 1   | 0    | 0   | 0   | 0   | 0   | 0   | 0   | 0   |
| BLUE        | BLUE (000) Dark  | 0                | 0   | 0   | 0   | 0   | 0   | 0   | 0   | 0     | 0   | 0   | 0   | 0   | 0   | 0   | 0   | 0    | 0   | 0   | 0   | 0   | 0   | 0   | 0   |
|             | BLUE (001)       | 0                | 0   | 0   | 0   | 0   | 0   | 0   | 0   | 0     | 0   | 0   | 0   | 0   | 0   | 0   | 0   | 0    | 0   | 0   | 0   | 0   | 0   | 0   | 1   |
|             | ...              | ...              |     |     |     |     |     |     |     | ...   |     |     |     |     |     |     |     | ...  |     |     |     |     |     |     |     |
|             | BLUE (254)       | 0                | 0   | 0   | 0   | 0   | 0   | 0   | 0   | 0     | 0   | 0   | 0   | 0   | 0   | 0   | 0   | 1    | 1   | 1   | 1   | 1   | 1   | 1   | 0   |
|             | BLUE (255)       | 0                | 0   | 0   | 0   | 0   | 0   | 0   | 0   | 0     | 0   | 0   | 0   | 0   | 0   | 0   | 0   | 1    | 1   | 1   | 1   | 1   | 1   | 1   | 1   |

**Note :** Users should be input true 8 Bit data streams via LVDS transmitter.

Product Specification

3-6. Power Sequence

3-6-1. LCD Driving circuit

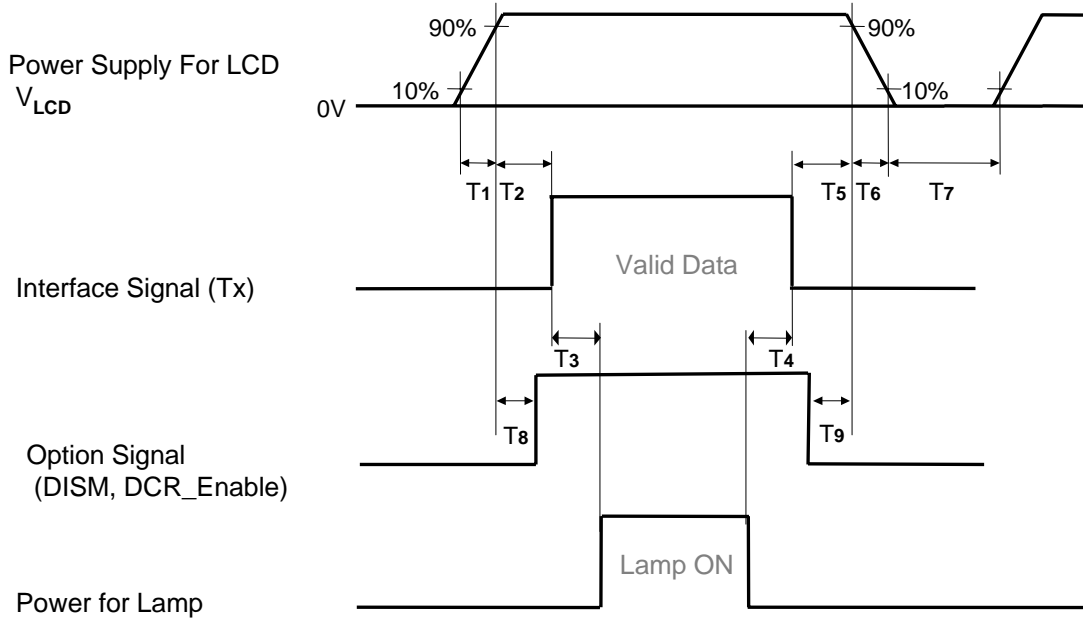

Table 9. POWER SEQUENCE

| Parameter | Value       |     |     | Unit |
|-----------|-------------|-----|-----|------|
|           | Min         | Typ | Max |      |
| T1        | 1.0         | -   | 20  | ms   |
| T2        | 5.0         | -   | 50  | ms   |
| T3        | 200         | -   | -   | ms   |
| T4        | 200         | -   | -   | ms   |
| T5        | 0.5         | -   | 50  | ms   |
| T6        | -           | -   | 300 | ms   |
| T7        | 2.0         | -   | -   | s    |
| T8        | 0 < T8 < T2 |     |     | ms   |
| T9        | 0 < T9 < T5 |     |     | ms   |

- Note :
1. Please avoid floating state of interface signal at invalid period.
  2. When the interface signal is invalid, be sure to pull down the power supply  $V_{LCD}$  to 0V.
  3. The case when the T2/T5 exceed maximum specification, it operates protection pattern(Black pattern) till valid signal inputted. There is no reliability problem.
  4. The T3/T4 is recommended value, the case when failed to meet a minimum specification, abnormal display would be shown. There is no reliability problem.
  5. If the on time of option signal(DISM or DCR\_Enable) precedes the on time of Power( $V_{LCD}$ ), check the LCD logic Power( $V_{cc}$ ) is under 0.8V, otherwise it will be happened abnormal display.

Product Specification

3-6-2. On/Off for Inverter

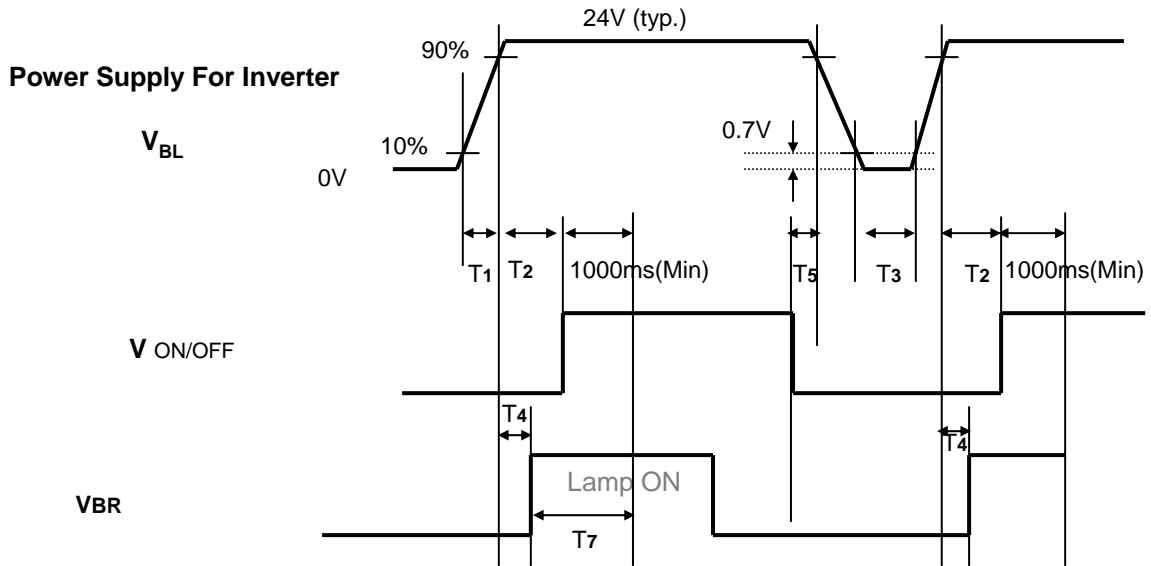

3-6-3. Deep condition for Inverter

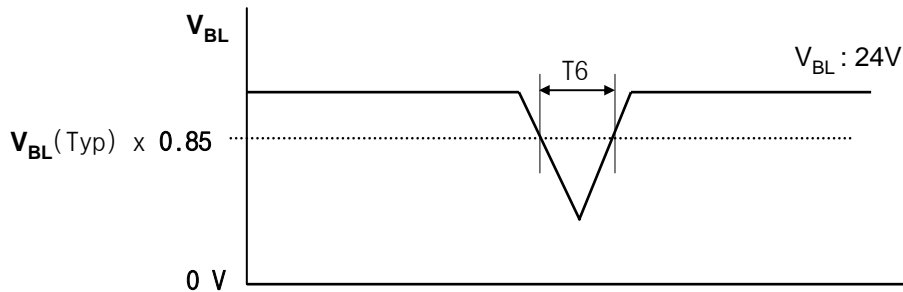

Table 10. Power Sequence for Inverter

| Parameter | Values |     |     | Units | Remarks                   |
|-----------|--------|-----|-----|-------|---------------------------|
|           | Min    | Typ | Max |       |                           |
| T1        | 20     | -   | -   | ms    | 1                         |
| T2        | 500    | -   | -   | ms    |                           |
| T3        | 200    | -   | -   | ms    | 2                         |
| T4        | 0      | -   | -   | ms    | 4, 5                      |
| T5        | 10     | -   | -   | ms    |                           |
| T6        | -      | -   | 10  | ms    | $V_{BL}(Typ) \times 0.85$ |
| T7        | 1000   | -   | -   | ms    |                           |

- Note : 1. T1 describes rising time of 0V to 24V and is not applied at restarting time.  
 3. When  $V_{BL}$  (24V) is supplied always, there is no reliability problem.  
 4. T4(max) is less than T2.  
 5. In T7 section, it recommended that  $V_{BR} = Max$ .



Product Specification

### 4. Optical Specification

Optical characteristics are determined after the unit has been 'ON' and stable in a dark environment at  $25 \pm 2^\circ\text{C}$ . The values are specified at an approximate distance 50cm from the LCD surface at a viewing angle of  $\Phi$  and  $\theta$  equal to  $0^\circ$ .

It is presented additional information concerning the measurement equipment and method in FIG. 1.

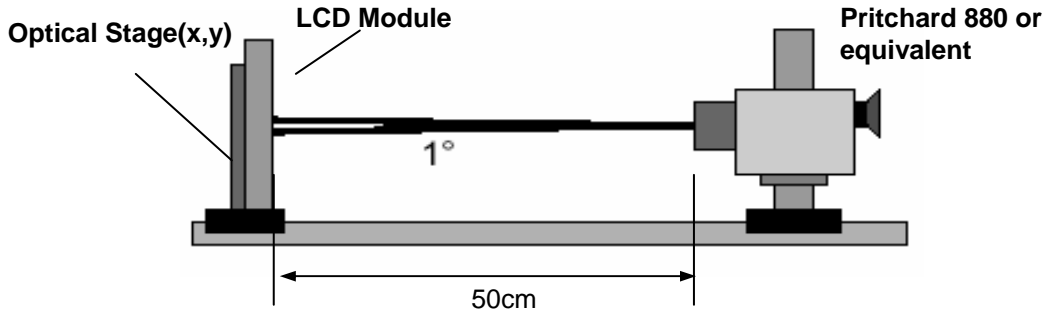

FIG. 1 Optical Characteristic Measurement Equipment and Method

Table 11. OPTICAL CHARACTERISTICS

$T_a = 25 \pm 2^\circ\text{C}$ ,  $V_{LCD} = 12.0\text{V}$ ,  $f_v = 60\text{Hz}$ ,  $D_{clk} = 72.3\text{MHz}$ ,  $V_{BR} = 3.3\text{V}$

| Parameter                       | Symbol                            | Value      |              |       | Unit            | Note   |   |
|---------------------------------|-----------------------------------|------------|--------------|-------|-----------------|--------|---|
|                                 |                                   | Min        | Typ          | Max   |                 |        |   |
| Contrast Ratio                  | CR                                | 400        | 600          |       |                 | 1      |   |
|                                 | CR with AI                        | 800        | 1200         |       |                 |        |   |
| Surface Luminance, white        | $L_{WH}$                          | 400        | 500          |       | $\text{cd/m}^2$ | 2      |   |
| Luminance Variation             | $\delta_{WHITE}$ 5P               |            |              | 1.3   |                 | 3      |   |
| Response Time<br>(Gray to Gray) | Rise Time                         | $Tr_R$     | -            | 8     | 12              |        | 4 |
|                                 | Decay Time                        | $Tr_D$     |              | 10    | 14              |        |   |
|                                 | G to G                            |            |              | -     | 9               | 14     |   |
| Color Coordinates<br>[CIE1931]  | RED                               | Rx         | Typ<br>-0.03 | 0.640 | Typ<br>+0.03    |        |   |
|                                 |                                   | Ry         |              | 0.343 |                 |        |   |
|                                 | GREEN                             | Gx         |              | 0.280 |                 |        |   |
|                                 |                                   | Gy         |              | 0.605 |                 |        |   |
|                                 | BLUE                              | Bx         |              | 0.145 |                 |        |   |
|                                 |                                   | By         |              | 0.065 |                 |        |   |
|                                 | WHITE                             | Wx         |              | 0.285 |                 |        |   |
|                                 |                                   | Wy         |              | 0.293 |                 |        |   |
| Viewing Angle (CR>10)           |                                   |            |              |       |                 |        |   |
|                                 | x axis, right( $\phi=0^\circ$ )   | $\theta_r$ | 85           | 89    | -               | degree | 5 |
|                                 | x axis, left ( $\phi=180^\circ$ ) | $\theta_l$ | 85           | 89    | -               |        |   |
|                                 | y axis, up ( $\phi=90^\circ$ )    | $\theta_u$ | 85           | 89    | -               |        |   |
|                                 | y axis, down ( $\phi=270^\circ$ ) | $\theta_d$ | 85           | 89    | -               |        |   |
| Gray Scale                      | Without AI                        |            |              |       |                 | 6      |   |
|                                 | With AI                           |            |              |       |                 |        |   |

Product Specification

Note :

1. Contrast Ratio(CR) is defined mathematically as :

$$\text{Contrast Ratio} = \frac{\text{Surface Luminance with all white pixels}}{\text{Surface Luminance with all black pixels}}$$

It is measured at center 1-point.

2. Surface Luminance( $L_{WH}$ ) is the luminance value at center 1-point across the LCD surface 50cm from the surface with all pixels displaying white. For more information see the FIG. 2.

3. The variation of surface luminance ,  $\delta$  WHITE is defined as :

$$\delta \text{ WHITE}(5P) = \text{Maximum}(L_{on1}, L_{on2}, L_{on3}, L_{on4}, L_{on5}) / \text{Minimum}(L_{on1}, L_{on2}, L_{on3}, L_{on4}, L_{on5})$$

Where  $L_{on1}$  to  $L_{on5}$  are the luminance with all pixels displaying white at 5 locations .  
For more information, see the FIG. 2.

4. Response time is the time required for the display to transition from G(N) to G(M) (Rise Time,  $Tr_R$ ) and from G(M) to G(N) (Decay Time,  $Tr_D$ ). For additional information see the FIG. 3. ( $N < M$ )

5. Viewing angle is the angle at which the contrast ratio is greater than 10. The angles are determined for the horizontal or x axis and the vertical or y axis with respect to the z axis which is normal to the LCD module surface. For more information, see the FIG. 4.

6. Gray scale specification

Gamma Value is approximately 2.2. For more information, see the Table 12.

**Table 12. GRAY SCALE SPECIFICATION**

| Gray Level | Luminance [%] (Typ) | Luminance [%] (Typ) with AI |
|------------|---------------------|-----------------------------|
| L0         | 0.13                | 0.05                        |
| L15        | 0.30                | 0.19                        |
| L31        | 1.22                | 0.71                        |
| L47        | 2.67                | 1.66                        |
| L63        | 4.85                | 3.21                        |
| L79        | 7.82                | 5.50                        |
| L95        | 11.6                | 8.53                        |
| L111       | 16.3                | 12.3                        |
| L127       | 21.8                | 16.6                        |
| L143       | 28.2                | 21.8                        |
| L159       | 35.5                | 28.9                        |
| L175       | 43.8                | 37.6                        |
| L191       | 53.1                | 47.8                        |
| L207       | 63.2                | 61.2                        |
| L223       | 74.5                | 75.2                        |
| L239       | 88.0                | 87.4                        |
| L255       | 100                 | 100                         |

Product Specification

Measuring point for surface luminance & measuring point for luminance variation

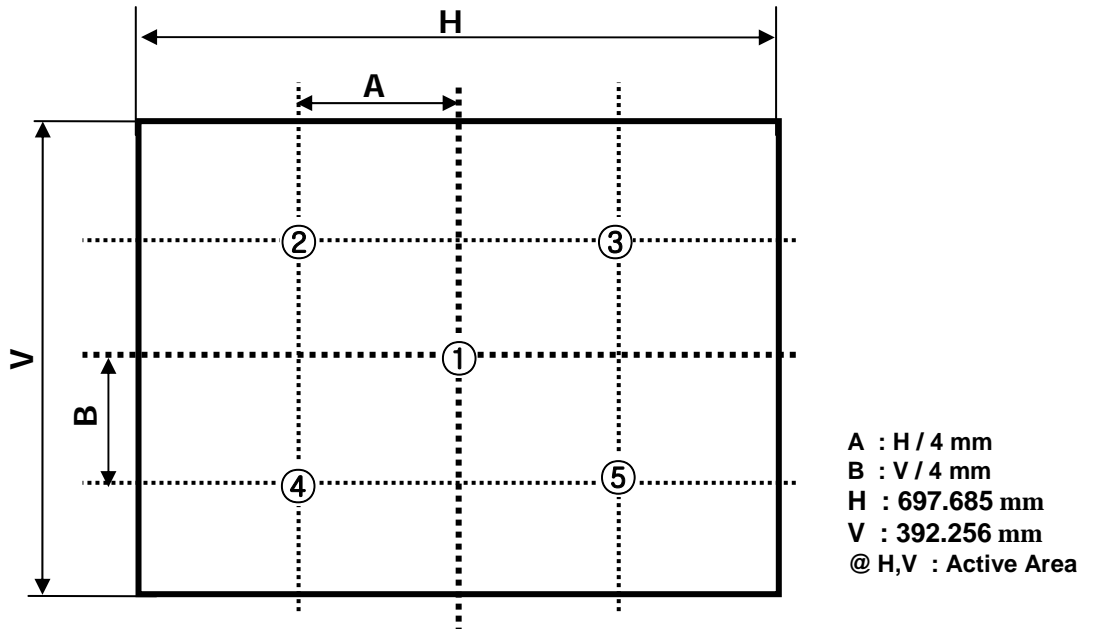

FIG. 2 The Position of Points for Luminance Measure

Response time is defined as the following figure and shall be measured by switching the input signal for "Gray(N)" and "Gray(M)".

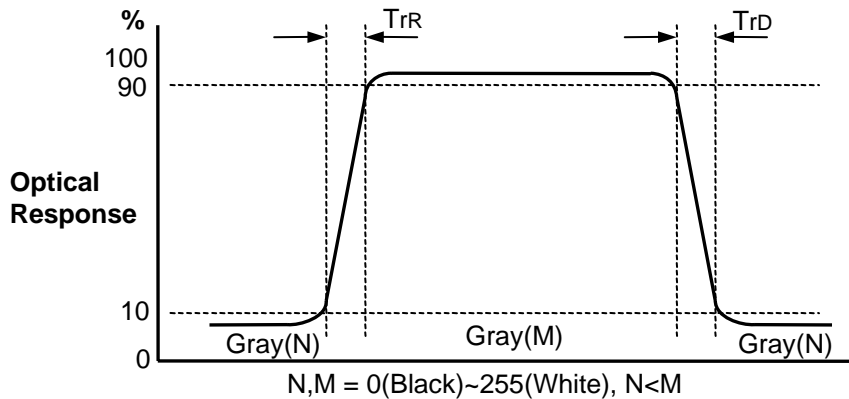

FIG. 3 Response Time

Product Specification

Dimension of viewing angle range

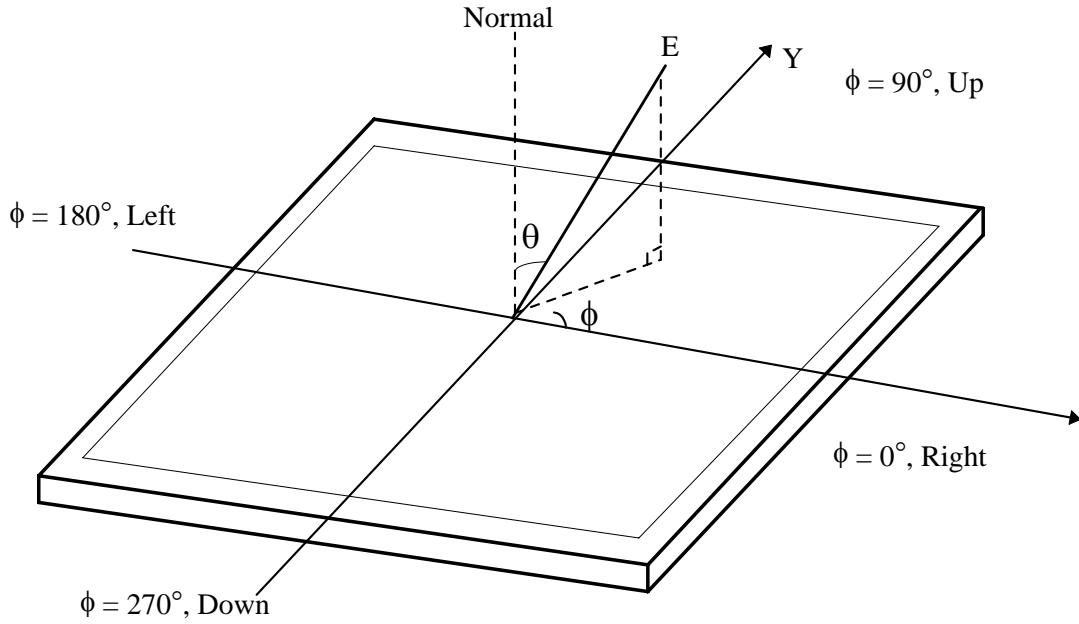

FIG. 4 Viewing Angle

Product Specification

## 5. Mechanical Characteristics

The following items provide general mechanical characteristics. In addition, the figures in the next page show the detail information of mechanical drawing for LCD module.

**Table 13. MECHANICAL CHARACTERISTICS**

|                     |   |           |
|---------------------|---|-----------|
| Outline Dimension   | Horizontal  | 760.0mm   |
|                     | Vertical  | 450.0 mm  |
|                     | Depth   | 48.0 mm   |
| Bezel Area          | Horizontal  | 703.8mm   |
|                     | Vertical  | 398.4mm   |
| Active Display Area | Horizontal  | 697.685mm |
|                     | Vertical  | 392.256mm |
| Weight              | 6,900 g(Typ.), 7,240 g(Max)                                     |           |
| Surface Treatment   | Hard coating(3H)<br>Anti-glare treatment of the front polarizer |           |

Notes : Please refer to a mechanic drawing in terms of tolerance at the next page.

**Product Specification**

<FRONT VIEW>

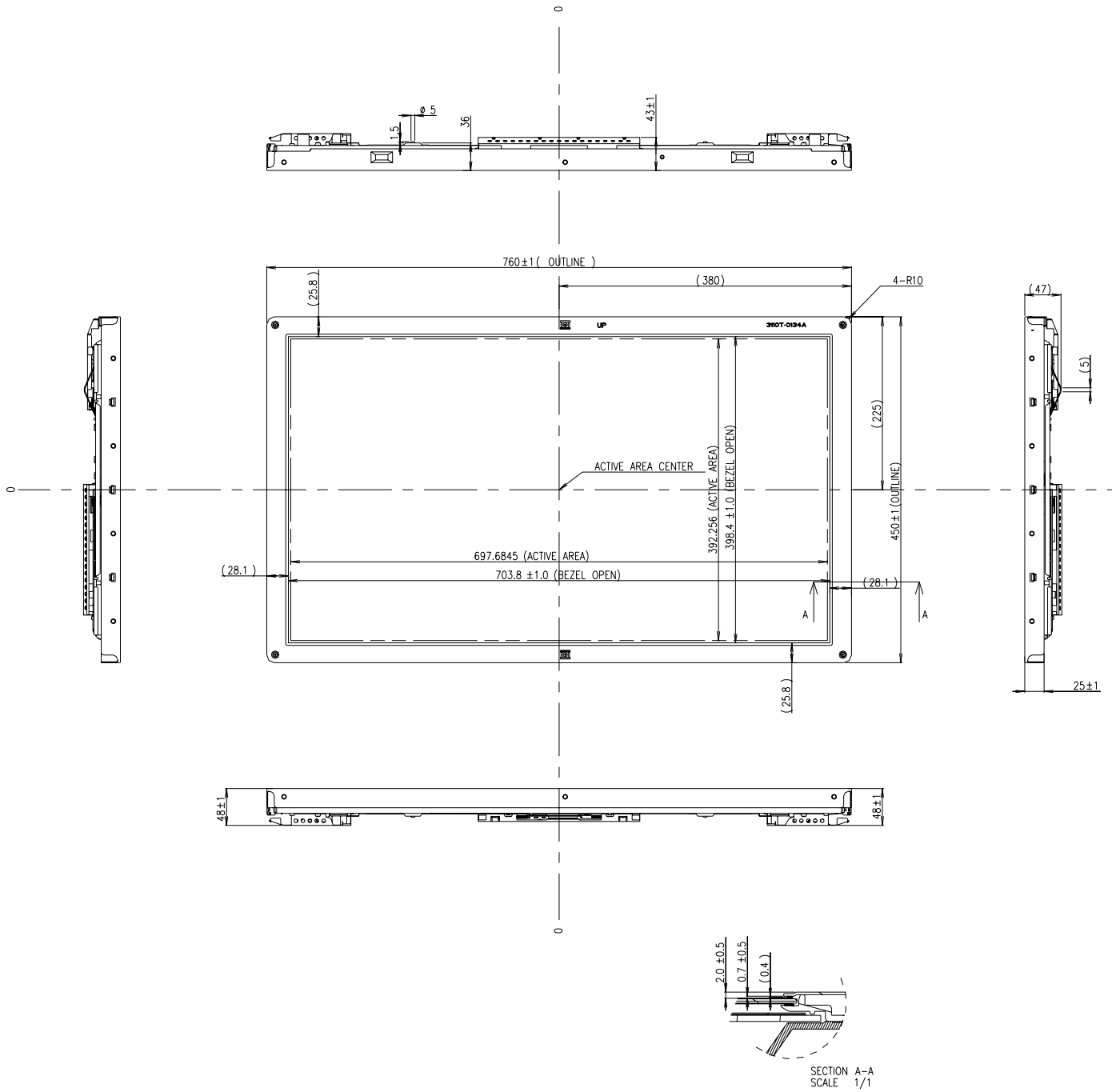

Product Specification

<REAR VIEW>

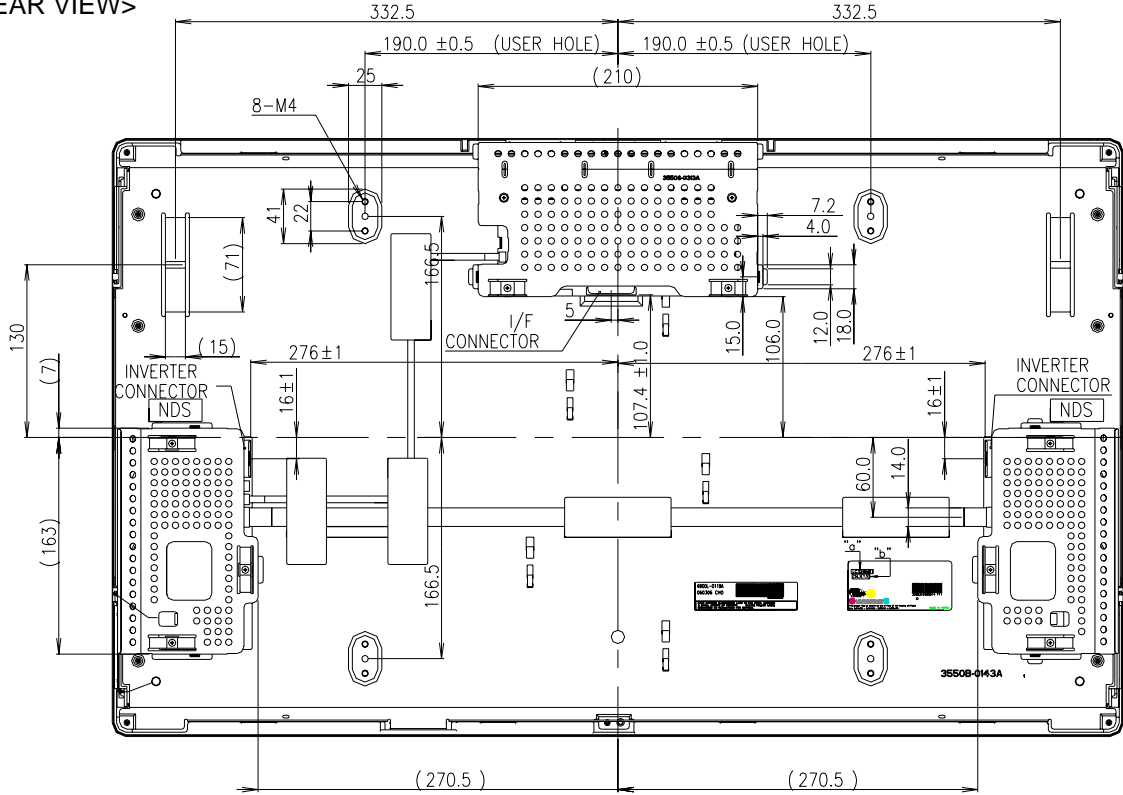

NOTES

1. I/F Connector Specification.  
- FI-X30SSL-HF(JAE) or Equivalent
2. INVERTER Connector Specification.  
- S12B-PHA-SM3(JST) or Equivalent
3. Depth of user hole screw insertion : Max 4mm.
4. Torque of user hole : Max 5.0kgf-cm.
5. Gap between Bezel and Panel : Max 1.2mm.
6. Tilt and partial disposition tolerance of display area as following.
  - (1) Y-Direction :  $|A-B| \leq 1.5$
  - (2) X-Direction :  $|C-D| \leq 1.5$

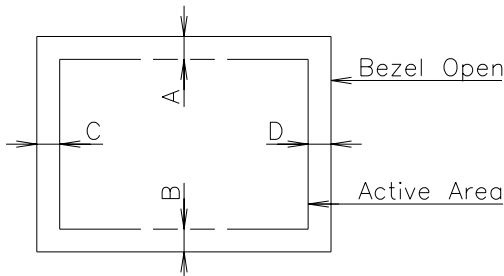

7. Unspecified tolerances to be  $\pm 0.5$ mm.

Product Specification

## 6. Reliability

**Table 14. ENVIRONMENT TEST CONDITION**

| No. | Test Item                                | Condition  |
|-----|--|--|
| 1   | High temperature storage test            | Ta= 50°C 240h  |
| 2   | Low temperature storage test             | Ta= -20°C 240h   |
| 3   | High temperature operation test          | Ta= 40°C 50%RH 240h  |
| 4   | Low temperature operation test           | Ta= 0°C 240h   |
| 5   | Vibration test<br>(operating)            | Wave form : random<br>Vibration level : 1.0Grms<br>Bandwidth : 10-300Hz<br>Duration : X,Y,Z, 30 min<br>One time each direction |
| 6   | Shock test<br>(operating)                | Shock level : 100Grms<br>Waveform : half sine wave, 2ms<br>Direction : ±X, ±Y, ±Z<br>One time each direction                   |
| 7   | Humidity condition Operation             | Ta= 40 °C 90%RH 240h   |
| 8   | Altitude operating<br>storage / shipment | 0 - 14,000 feet(4267.2m)<br>0 - 40,000 feet(12192m)  |



## 7. International Standards

### 7-1. Safety

- a) UL 60065, 7<sup>th</sup> Edition, dated June 30, 2003, Underwriters Laboratories, Inc., Standard for Audio, Video and Similar Electronic Apparatus.
- b) CAN/CSA C22.2, No. 60065:03, Canadian Standards Association, Standard for Audio, Video and Similar Electronic Apparatus.
- c) IEC60065:2001, 7<sup>th</sup> Edition CB-scheme and EN 60065:2002, Safety requirements for Audio, Video and Similar Electronic Apparatus..

### 7-2. EMC

- a) ANSI C63.4 "Methods of Measurement of Radio-Noise Emissions from Low-Voltage Electrical and Electrical Equipment in the Range of 9kHz to 40GHz. "American National Standards Institute(ANSI), 1992
- b) CISPR22 "Limits and Methods of Measurement of Radio Interface Characteristics of Information Technology Equipment." International Special Committee on Radio Interference.
- c) EN 55022 "Limits and Methods of Measurement of Radio Interface Characteristics of Information Technology Equipment." European Committee for Electrotechnical Standardization.(CENELEC), 1998 ( Including A1: 2000 )

Product Specification

## 8. Packing

### 8-1. Designation of Lot Mark

a) Lot Mark

|   |   |   |   |   |   |   |   |   |   |   |   |   |
|---|---|---|---|---|---|---|---|---|---|---|---|---|
| A | B | C | D | E | F | G | H | I | J | K | L | M |
|---|---|---|---|---|---|---|---|---|---|---|---|---|

A,B,C : SIZE(INCH)  
E : MONTH

D : YEAR  
F ~ M : SERIAL NO.

Note

1. YEAR

|      |      |      |      |      |      |      |      |      |      |      |
|------|------|------|------|------|------|------|------|------|------|------|
| Year | 2001 | 2002 | 2003 | 2004 | 2005 | 2006 | 2007 | 2008 | 2009 | 2010 |
| Mark | 1    | 2    | 3    | 4    | 5    | 6    | 7    | 8    | 9    | 0    |

2. MONTH

|       |     |     |     |     |     |     |     |     |     |     |     |     |
|-------|-----|-----|-----|-----|-----|-----|-----|-----|-----|-----|-----|-----|
| Month | Jan | Feb | Mar | Apr | May | Jun | Jul | Aug | Sep | Oct | Nov | Dec |
| Mark  | 1   | 2   | 3   | 4   | 5   | 6   | 7   | 8   | 9   | A   | B   | C   |

b) Location of Lot Mark

Serial No. is printed on the label. The label is attached to the backside of the LCD module.  
This is subject to change without prior notice.

### 8-2. Packing Form

a) Package quantity in one box : 6 pcs

b) Box size : 848mm(W) X 494mm(D) X 539mm(H)

## Product Specification

## 9. Precautions

Please pay attention to the followings when you use this TFT LCD module.

### 9-1. Mounting Precautions

- (1) You must mount a module using holes arranged in four corners or four sides.
- (2) You should consider the mounting structure so that uneven force (ex. Twisted stress) is not applied to the module. And the case on which a module is mounted should have sufficient strength so that external force is not transmitted directly to the module.
- (3) Please attach the surface transparent protective plate to the surface in order to protect the polarizer. Transparent protective plate should have sufficient strength in order to resist external force.
- (4) You should adopt radiation structure to satisfy the temperature specification.
- (5) Acetic acid type and chlorine type materials for the cover case are not desirable because the former generates corrosive gas of attacking the polarizer at high temperature and the latter causes circuit break by electro-chemical reaction.
- (6) Do not touch, push or rub the exposed polarizers with glass, tweezers or anything harder than HB pencil lead. And please do not rub with dust clothes with chemical treatment. Do not touch the surface of polarizer for bare hand or greasy cloth.(Some cosmetics are detrimental to the polarizer.)
- (7) When the surface becomes dusty, please wipe gently with absorbent cotton or other soft materials like chamois soaks with petroleum benzene. Normal-hexane is recommended for cleaning the adhesives used to attach front / rear polarizers. Do not use acetone, toluene and alcohol because they cause chemical damage to the polarizer.
- (8) Wipe off saliva or water drops as soon as possible. Their long time contact with polarizer causes deformations and color fading.
- (9) Do not open the case because inside circuits do not have sufficient strength.

### 9-2. Operating Precautions

- (1) The spike noise causes the mis-operation of circuits. It should be lower than following voltage :  
 $V = \pm 200\text{mV}$  (Over and under shoot voltage)
- (2) Response time depends on the temperature.(In lower temperature, it becomes longer.)
- (3) Brightness depends on the temperature. (In lower temperature, it becomes lower.)  
And in lower temperature, response time(required time that brightness is stable after turned on) becomes longer.
- (4) Be careful for condensation at sudden temperature change. Condensation makes damage to polarizer or electrical contacted parts. And after fading condensation, smear or spot will occur.
- (5) When fixed patterns are displayed for a long time, remnant image is likely to occur.
- (6) Module has high frequency circuits. Sufficient suppression to the electromagnetic interference shall be done by system manufacturers. Grounding and shielding methods may be important to minimized the interference.
- (7) Please do not give any mechanical and/or acoustical impact to LCM. Otherwise, LCM can't be operated its full characteristics perfectly.
- (8) A screw which is fastened up the steels should be a machine screw.  
(if not, it causes metallic foreign material and deal LCM a fatal blow)
- (9) Please do not set LCD on its edge.

## Product Specification

### 9-3. Electrostatic Discharge Control

Since a module is composed of electronic circuits, it is not strong to electrostatic discharge. Make certain that treatment persons are connected to ground through wrist band etc. And don't touch interface pin directly.

### 9-4. Precautions for Strong Light Exposure

Strong light exposure causes degradation of polarizer and color filter.

### 9-5. Storage

When storing modules as spares for a long time, the following precautions are necessary.

- (1) Store them in a dark place. Do not expose the module to sunlight or fluorescent light. Keep the temperature between 5°C and 35°C at normal humidity.
- (2) The polarizer surface should not come in contact with any other object.  
It is recommended that they be stored in the container in which they were shipped.

### 9-6. Handling Precautions for Protection Film

- (1) The protection film is attached to the bezel with a small masking tape.  
When the protection film is peeled off, static electricity is generated between the film and polarizer. This should be peeled off slowly and carefully by people who are electrically grounded and with well ion-blown equipment or in such a condition, etc.
- (2) When the module with protection film attached is stored for a long time, sometimes there remains a very small amount of glue still on the bezel after the protection film is peeled off.
- (3) You can remove the glue easily. When the glue remains on the bezel surface or its vestige is recognized, please wipe them off with absorbent cotton waste or other soft material like chamois soaked with normal-hexane.

### 9-7. Appropriate Condition for Public Display

- Generally large-sized LCD modules are designed for consumer applications (TV).

Accordingly, a long-term display like in Public Display (PD) application, can cause uneven display including image sticking. To optimize module's lifetime and function, several operating usages are required.

#### 1. Normal operating condition

- Temperature: 0 ~ 40°C
- Operating Ambient Humidity : 10 ~ 90 %
- Display pattern: dynamic pattern (Real display)

Note) Long-term static display can cause image sticking.

#### 2. Operating usages under abnormal condition<sup>1</sup>

##### a. Ambient condition

- Well-ventilated place is recommended to set up PD system.

##### b. Power and screen save

- Periodical power-off or screen save is needed after long-term display.[3.2]

## Product Specification

3. Operating usages to protect against image sticking due to long-term static display
  - a. Suitable operating time: under 18 hours a day.
  - b. Static information display recommended to use with moving image.
    - Cycling display between 5 minutes' information(static) display and 10 seconds' moving image.
  - c. Background and character (image) color change
    - Use different colors for background and character, respectively.
    - Change colors themselves periodically.
  - d. Avoid combination of background and character with large different luminance.
    - 1) Abnormal condition just means conditions except normal condition.
    - 2) Black image or moving image is strongly recommended as a screen save.
4. Lifetime in this spec. is guaranteed only when PD is used according to operating usages.

- The attached figure of the AI\_ENABLE Circuit Block Diagram on the Control PCB ass'y

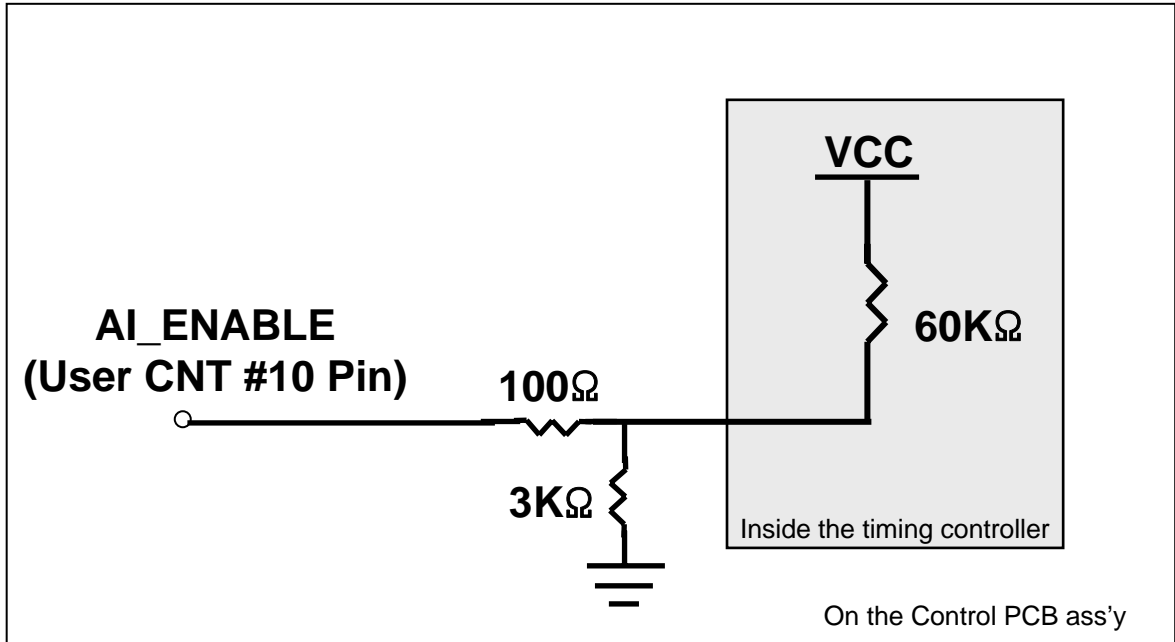

Fig.5 The AI\_ENABLE Circuit Block Diagram