



LC370EUN

Product Specification

SPECIFICATION FOR APPROVAL

(●) Preliminary Specification

() Final Specification

Title	37.0" WUXGA TFT LCD
-------	---------------------

BUYER	SKYWORTH
MODEL	

SUPPLIER	LG Display Co., Ltd.
*MODEL	LC370EUN
SUFFIX	SEF1

*When you obtain standard approval,
please use the above model name without suffix

APPROVED BY	SIGNATURE DATE
/	
/	
/	

Please return 1 copy for your confirmation with your signature and comments.

APPROVED BY	SIGNATURE DATE
J.T. Kim / Team Leader	
REVIEWED BY	
J.K. Park / Project Leader	
PREPARED BY	
S.W. Kwag / Engineer	

**TV Product Development Dept.
LG Display Co., Ltd.**

LC370EUN

Product Specification

CONTENTS

Number	ITEM	Page
	COVER	1
	CONTENTS	2
	RECORD OF REVISIONS	3
1	GENERAL DESCRIPTION	4
2	ABSOLUTE MAXIMUM RATINGS	5
3	ELECTRICAL SPECIFICATIONS	6
3-1	ELECTRICAL CHARACTERISTICS	6
3-2	INTERFACE CONNECTIONS	8
3-3	SIGNAL TIMING SPECIFICATIONS	11
3-4	SIGNAL TIMING WAVEFORMS	12
3-5	COLOR DATA REFERENCE	14
3-6	POWER SEQUENCE	15
4	OPTICAL SPECIFICATIONS	17
5	MECHANICAL CHARACTERISTICS	23
6	RELIABILITY	26
7	INTERNATIONAL STANDARDS	27
7-1	SAFETY	27
7-2	EMC	27
7-3	ENVIRONMENT	27
8	PACKING	28
8-1	DESIGNATION OF LOT MARK	28
8-2	PACKING FORM	28
9	PRECAUTIONS	29
9-1	MOUNTING PRECAUTIONS	29
9-2	OPERATING PRECAUTIONS	29
9-3	ELECTROSTATIC DISCHARGE CONTROL	30
9-4	PRECAUTIONS FOR STRONG LIGHT EXPOSURE	30
9-5	STORAGE	30
9-6	HANDLING PRECAUTIONS FOR PROTECTION FILM	30
9-7	OPERATING GONDITION GUIDE	30

Ver. 0.1

2 / 30

LC370EUN

Product Specification

1. General Description

The LC370EUN is a Color Active Matrix Liquid Crystal Display with an integral Light Emitting Diode (LED) backlight system. The matrix employs a-Si Thin Film Transistor as the active element. It is a transmissive display type which is operating in the normally black mode. It has a 42.02 inch diagonally measured active display area with WUXGA resolution (1080 vertical by 1920 horizontal pixel array). Each pixel is divided into Red, Green and Blue sub-pixels or dots which are arrayed in vertical stripes. Gray scale or the luminance of the sub-pixel color is determined with a 8-bit gray scale signal for each dot. Therefore, it can present a palette of more than 16.7 Million colors.

It has been designed to apply the 8-bit 2-port LVDS interface.

It is intended to support LCD TV, PCTV where high brightness, super wide viewing angle, high color gamut, high color depth and fast response time are important.

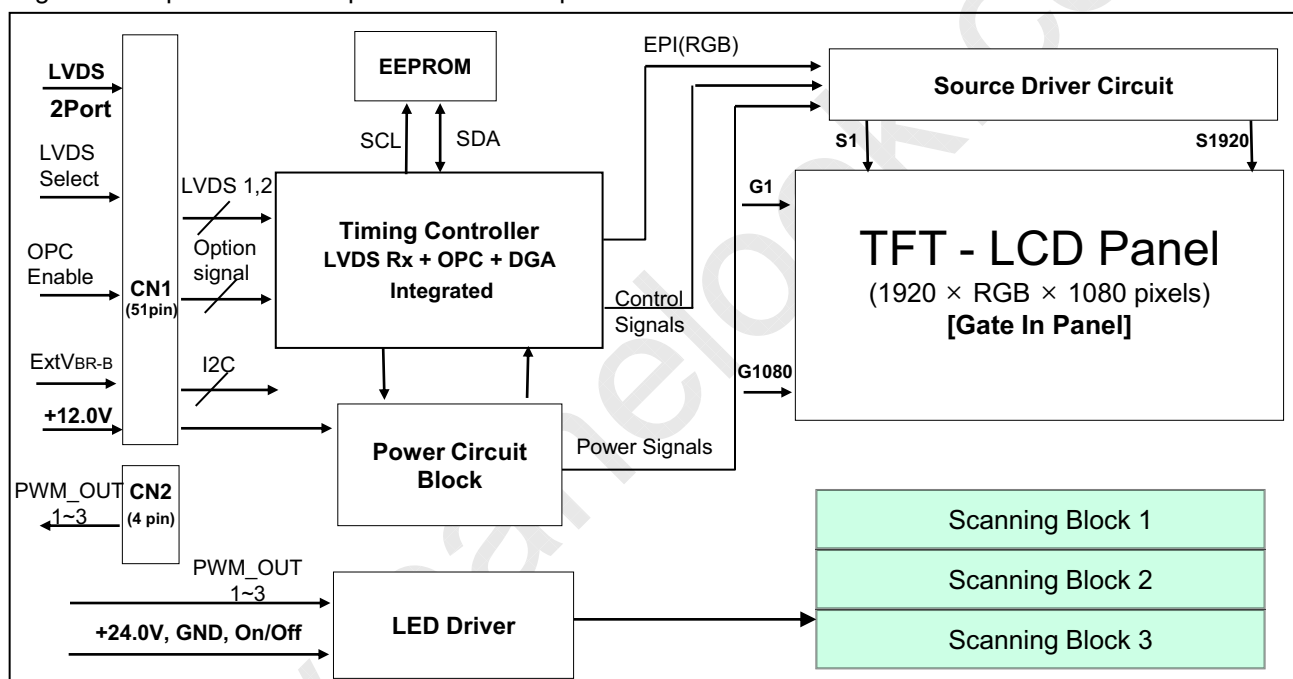

General Features

Active Screen Size	36.5 inches(927.2mm) diagonal
Outline Dimension	837.2(H) × 490.6(V) X 9.9(B) /22.7 mm(D) (Typ.)
Pixel Pitch	0.4209 mm x 0.4209 mm
Pixel Format	1920 horiz. by 1080 vert. Pixels, RGB stripe arrangement
Color Depth	8bit, 16.7 Million colors
Luminance, White	360 cd/m ² (Center 1point ,Typ.)
Viewing Angle (CR>10)	Viewing angle free (R/L 178 (Min.), U/D 178 (Min.))
Power Consumption	Total 47.1W (Typ.) [Logic= 6.1W, LED Driver=41(TBD)W (ExtVbr_B=100%)]
Weight	7.5 Kg (Typ.)
Display Mode	Transmissive mode, Normally black
Surface Treatment	Hard coating(2H), Anti-glare treatment of the front polarizer (Haze 10%)

Ver. 0.1

4 / 30

LC370EUN

Product Specification

2. Absolute Maximum Ratings

The following items are maximum values which, if exceeded, may cause faulty operation or permanent damage to the LCD module.

Table 1. ABSOLUTE MAXIMUM RATINGS

Parameter		Symbol	Value		Unit	Note
			Min	Max		
Power Input Voltage	LCD Circuit	V _{LCD}	-0.3	+14.0	V _{DC}	
	Driver	V _{BL}	-0.3	+27.0	V _{DC}	
Driver Control Voltage	ON/OFF	V _{OFF} / V _{ON}	-0.3	+5.5	V _{DC}	1
	Brightness	EXT V _{BR-B}	-0.3	+4.0	V _{DC}	
T-Con Option Selection Voltage		V _{LOGIC}	-0.3	+4.0	V _{DC}	
Operating Temperature		T _{OP}	0	+50	°C	2,3
Storage Temperature		T _{ST}	-20	+60	°C	
Panel Front Temperature		T _{SUR}	-	+68	°C	4
Operating Ambient Humidity		H _{OP}	10	90	%RH	2,3
Storage Humidity		H _{ST}	10	90	%RH	

Notes 1. Ambient temperature condition ($T_a = 25 \pm 2 \text{ }^\circ\text{C}$)

2. Temperature and relative humidity range are shown in the figure below.

Wet bulb temperature should be Max 39°C, and no condensation of water.

3. Gravity mura can be guaranteed below 40°C condition.

4. The maximum operating temperatures is based on the test condition that the surface temperature of display area is less than or equal to 68°C with LCD module alone in a temperature controlled chamber. Thermal management should be considered in final product design to prevent the surface temperature of display area from being over 68°C. The range of operating temperature may be degraded in case of improper thermal management in final product design.

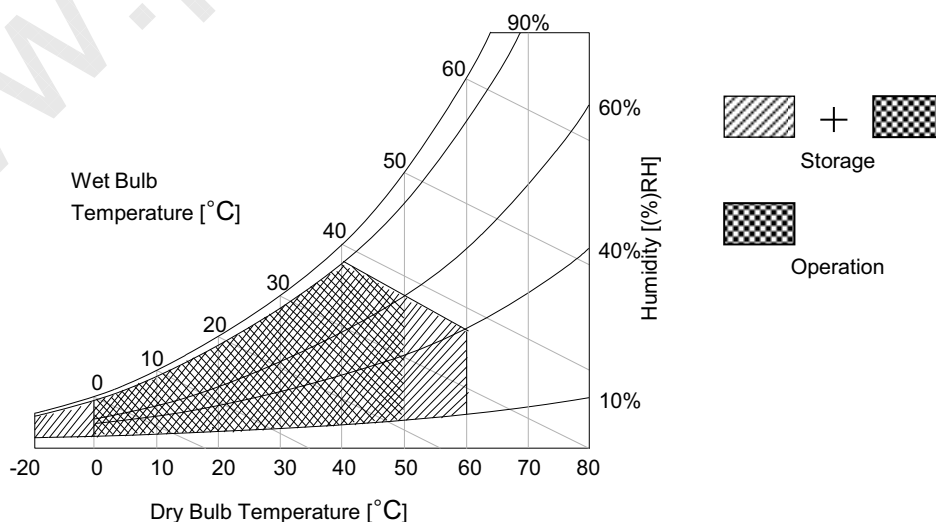

LC370EUN

Product Specification

3. Electrical Specifications

3-1. Electrical Characteristics

It requires two power inputs. One is employed to power for the LCD circuit. The other is used for the LED backlight and LED Driver circuit.

Table 2. ELECTRICAL CHARACTERISTICS

Parameter	Symbol	Value			Unit	Note
		Min	Typ	Max		
Circuit :						
Power Input Voltage	V _{LCD}	10.8	12.0	13.2	V _{dc}	
Power Input Current	I _{LCD}	-	510 (TBD)	665 (TBD)	mA	1
		-	760 (TBD)	990 (TBD)	mA	2
Power Consumption	P _{LCD}		6.1 (TBD)	7.9 (TBD)	Watt	1
Rush current	I _{RUSH}	-	-	3.0	A	3
Brightness Adjust for Back Light	ExtV _{BR-B}	5	-	100	%	On Duty 4
		1	-	100	%	
	ExtV _{BR-B} Frequency	40	50/60	80	Hz	
Pulse Duty Level (PWM)	High Level	2.5	-	3.6	V _{dc}	HIGH : on duty LOW : off duty
	Low Level	0	-	0.8	V _{dc}	

Notes 1. The specified current and power consumption are under the V_{LCD}=12.0V, T_a=25 ± 2°C, f_v=60Hz condition, and mosaic pattern(8 x 6) is displayed and f_v is the frame frequency.

2. The current is specified at the maximum current pattern.

3. The duration of rush current is about 2ms and rising time of power input is 0.5ms (min.).

4. ExtV_{BR-B} signal have to input available duty range and sequence.

After Driver ON signal is applied, ExtV_{BR-B} should be sustained from 5% to 100% more than 500ms.

After that, ExtV_{BR-B} 1% and 100% is possible

For more information, please see 3-6-2. Sequence for LED Driver.

5. Ripple voltage level is recommended under ±5% of typical voltage

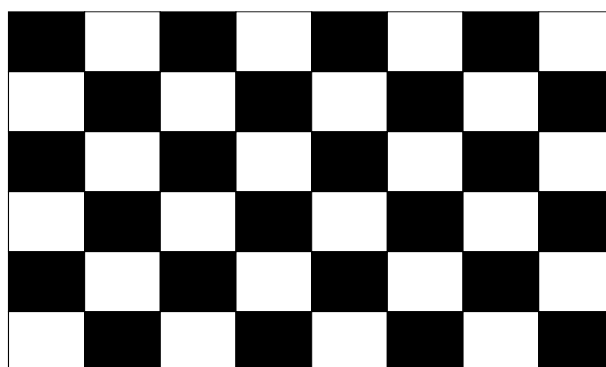

White : 255 Gray
Black : 0 Gray

Mosaic Pattern(8 x 6)

LC370EUN

Product Specification

Table 3. ELECTRICAL CHARACTERISTICS (Continue)

Parameter			Symbol	Values			Unit	Notes
				Min	Typ	Max		
LED Driver :								
Power Supply Input Voltage			VBL	22.8	24.0	25.2	Vdc	1
Power Supply Input Current			IBL	-	1.7 (TBD)	2.0 (TBD)	A	1
Power Supply Input Current (In-Rush)			In-rush	-	-	2.5 (TBD)	A	VBL = 22.8V ExtV _{BR-B} = 100% 3
Power Consumption			PBL	-	41 (TBD)	44.7 (TBD)	W	1
Input Voltage for Control System Signals	On/Off	On	V on	2.5	-	5.0	Vdc	
		Off	V off	-0.3	0.0	0.7	Vdc	
LED :								
Life Time				30,000	50,000		Hrs	2

Notes :

1. Electrical characteristics are determined after the unit has been 'ON' and stable for approximately 60 minutes at $25\pm 2^{\circ}\text{C}$. The specified current and power consumption are under the typical supply Input voltage 24V and VBR (ExtV_{BR-B} : 100%), it is total power consumption.
2. The life time (MTTF) is determined as the time which luminance of the LED is 50% compared to that of initial value at the typical LED current (ExtV_{BR-B} : 100%) on condition of continuous operating in LCM state at $25\pm 2^{\circ}\text{C}$.
3. The duration of rush current is about 200ms. This duration is applied to LED on time.
4. Even though inrush current is over the specified value, there is no problem if I²T spec of fuse is satisfied.

Product Specification

3-2. Interface Connections

This LCD module employs two kinds of interface connection, 51-pin connector is used for the module electronics and 14-pin connector is used for the integral backlight system.

3-2-1. LCD Module

- LCD Connector(CN1) : FI-R51S-HF(manufactured by JAE) or compatible
- Mating Connector : FI-R51HL(JAE) or compatible

Table 4. MODULE CONNECTOR(CN1) PIN CONFIGURATION

No	Symbol	Description	No	Symbol	Description
1	NC	No Connection (Note 4)	27	NC	No connection
2	NC	No Connection (Note 4)	28	R2AN	SECOND LVDS Receiver Signal (A-)
3	NC	No Connection (Note 4)	29	R2AP	SECOND LVDS Receiver Signal (A+)
4	NC	No Connection (Note 4)	30	R2BN	SECOND LVDS Receiver Signal (B-)
5	NC	No Connection (Note 4)	31	R2BP	SECOND LVDS Receiver Signal (B+)
6	NC	No Connection (Note 4)	32	R2CN	SECOND LVDS Receiver Signal (C-)
7	LVDS Select	'H' =JEIDA , 'L' or NC = VESA	33	R2CP	SECOND LVDS Receiver Signal (C+)
8	ExtVBR-B	External PWM (from System)	34	GND	Ground
9	NC	No Connection (Notes 4)	35	R2CLKN	SECOND LVDS Receiver Clock Signal(-)
10	OPC Enable	'H' = Enable , 'L' or NC = Disable	36	R2CLKP	SECOND LVDS Receiver Clock Signal(+)
11	GND	Ground	37	GND	Ground
12	R1AN	FIRST LVDS Receiver Signal (A-)	38	R2DN	SECOND LVDS Receiver Signal (D-)
13	R1AP	FIRST LVDS Receiver Signal (A+)	39	R2DP	SECOND LVDS Receiver Signal (D+)
14	R1BN	FIRST LVDS Receiver Signal (B-)	40	NC	No connection
15	R1BP	FIRST LVDS Receiver Signal (B+)	41	NC	No connection
16	R1CN	FIRST LVDS Receiver Signal (C-)	42	NC or GND	No Connection or Ground
17	R1CP	FIRST LVDS Receiver Signal (C+)	43	NC or GND	No Connection or Ground
18	GND	Ground	44	GND	Ground
19	R1CLKN	FIRST LVDS Receiver Clock Signal(-)	45	GND	Ground
20	R1CLKP	FIRST LVDS Receiver Clock Signal(+)	46	GND	Ground
21	GND	Ground	47	NC	No connection
22	R1DN	FIRST LVDS Receiver Signal (D-)	48	VLCD	Power Supply +12.0V
23	R1DP	FIRST LVDS Receiver Signal (D+)	49	VLCD	Power Supply +12.0V
24	NC	No connection	50	VLCD	Power Supply +12.0V
25	NC	No connection	51	VLCD	Power Supply +12.0V
26	NC or GND	No Connection or Ground	-	-	-

- Notes
1. All GND(ground) pins should be connected together to the LCD module's metal frame.
 2. All VLCD (power input) pins should be connected together.
 3. All Input levels of LVDS signals are based on the EIA 644 Standard.
 4. #1~#6 & #9 NC (No Connection): These pins are used only for LGD (Do not connect)
 5. Specific pins(pin No. #10) are used for OPC function of the LCD module.
If not used, these pins are no connection. (Please see the Appendix VI for more information.)
 6. Specific pin No. #44 is used for "No signal detection" of system signal interface.
It should be GND for NSB(No Signal Black) during the system interface signal is not.
If this pin is "H", LCD Module displays AGP(Auto Generation Pattern).

LC370EUN

Product Specification

3-2-2. Backlight Module

Master

- LED Driver Connector
: 20022WR - H14B2 (Yeonho) or Compatible
- Mating Connector
: 20022HS - 14B2 or Compatible

Table 5-1. LED DRIVER CONNECTOR PIN CONFIGURATION

Pin No	Symbol	Description	Note
1	VBL	Power Supply +24.0V	
2	VBL	Power Supply +24.0V	
3	VBL	Power Supply +24.0V	
4	VBL	Power Supply +24.0V	
5	VBL	Power Supply +24.0V	
6	GND	Backlight Ground	
7	GND	Backlight Ground	
8	GND	Backlight Ground	1
9	GND	Backlight Ground	
10	GND	Backlight Ground	
11	Status	Back Light Status	2
12	VON/OFF	Backlight ON/OFF control	
13	NC	Don't care	
14	NC	Don't care	

Notes :1. GND should be connected to the LCD module's metal frame.

2. Normal : Low (under 0.7V) / Abnormal : Open

3. Each impedance of pin #12 is over 50 [KΩ]

◆ Rear view of LCM

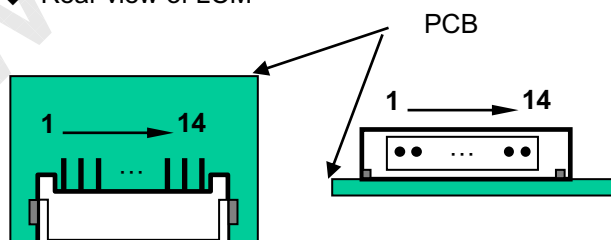

<Master>

LC370EUN

Product Specification

3-3. Signal Timing Specifications

Table 6 shows the signal timing required at the input of the LVDS transmitter. All of the interface signal timings should be satisfied with the following specification for normal operation.

Table 6. TIMING TABLE (DE Only Mode)

ITEM		Symbol	Min	Typ	Max	Unit	Note
Horizontal	Display Period	tHV	960	960	960	tCLK	1920 / 2
	Blank	tHB	100	140	240	tCLK	1
	Total	top	1060	1100	1200	tCLK	
Vertical	Display Period	tVv	1080	1080	1080	Lines	
	Blank	tVb	20 (228)	45 (270)	69 (300)	Lines	1
	Total	tVp	1100 (1308)	1125 (1350)	1149 (1380)	Lines	

ITEM		Symbol	Min	Typ	Max	Unit	Note
Frequency	DCLK	fCLK	63.00	74.25	78.00	MHz	
	Horizontal	fH	57.3	67.5	70	KHz	2
	Vertical	fV	57 (47)	60 (50)	63 (53)	Hz	2 NTSC (PAL)

Note: 1. The input of HSYNC & VSYNC signal does not have an effect on normal operation (DE Only Mode).
If you use spread spectrum of EMI, add some additional clock to minimum value for clock margin.

2. The performance of the electro-optical characteristics may be influenced by variance of the vertical refresh rate and the horizontal frequency

※ Timing should be set based on clock frequency.

Product Specification

3-4. LVDS Signal Specification

3-4-1. LVDS Input Signal Timing Diagram

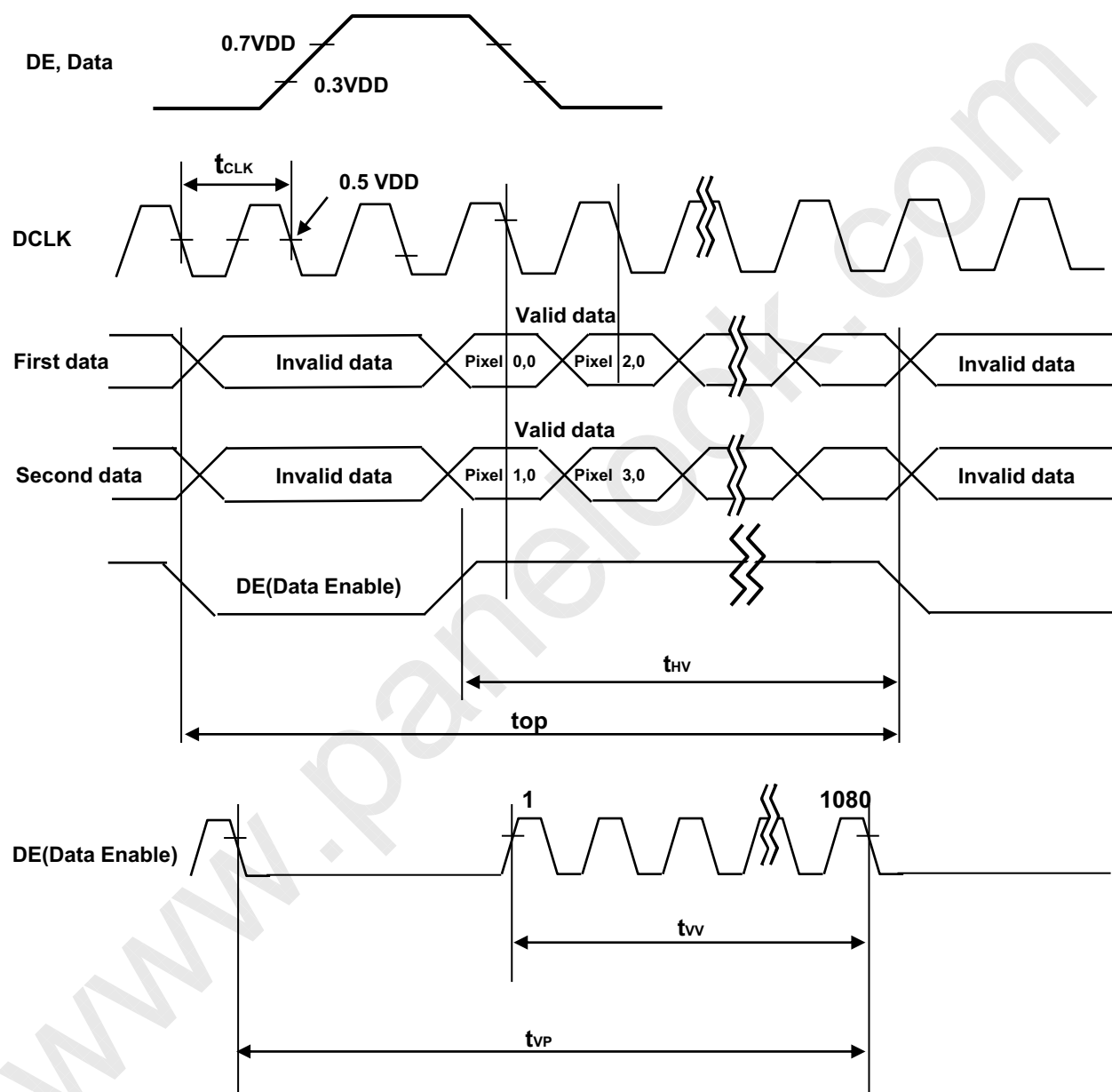

LC370EUN

Product Specification

3-4-2. LVDS Input Signal Characteristics

1) DC Specification

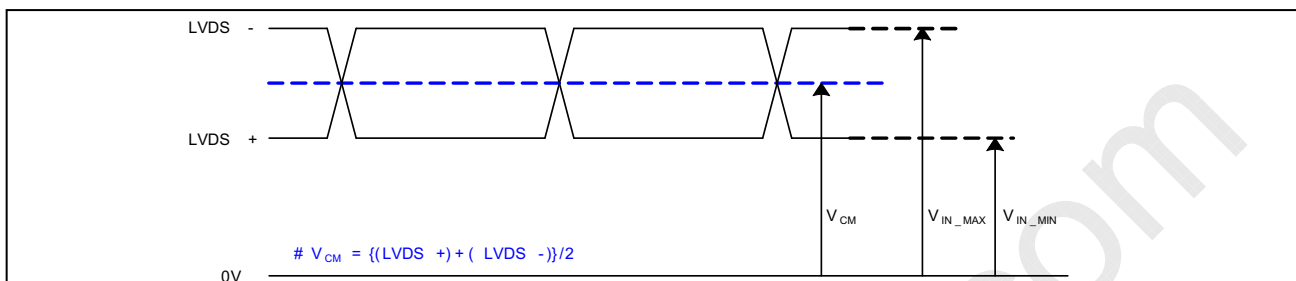

Description	Symbol	Min	Max	Unit	Note
LVDS Common mode Voltage	V_{CM}	1.0	1.5	V	-
LVDS Input Voltage Range	V_{IN}	0.7	1.8	V	-
Change in common mode Voltage	ΔV_{CM}	-	250	mV	-

2) AC Specification

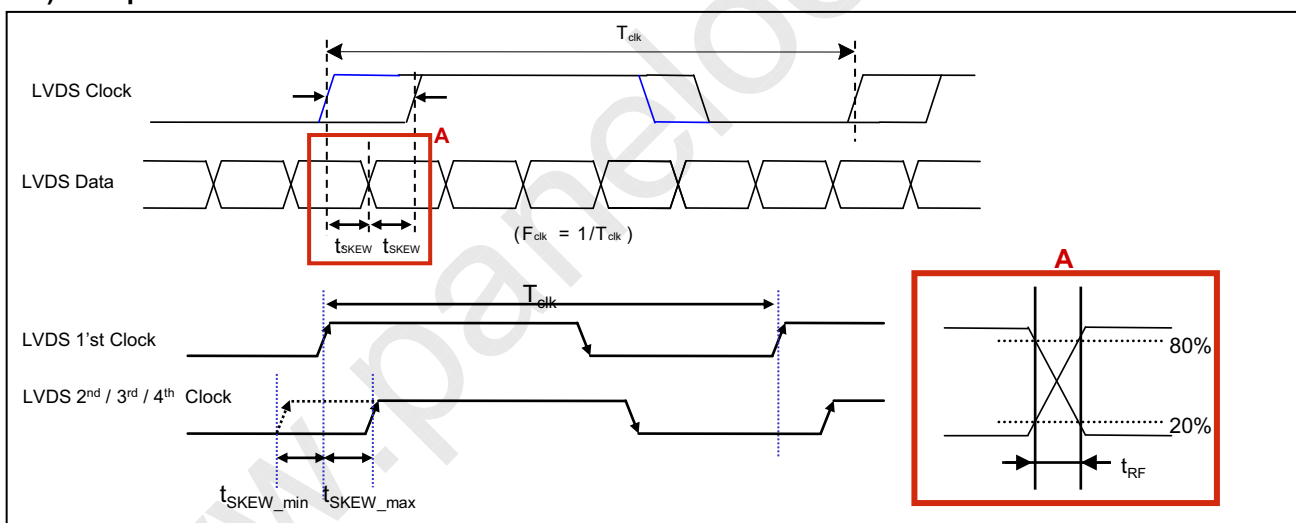

Description	Symbol	Min	Max	Unit	Note	
LVDS Differential Voltage	High Threshold	V_{TH}	100	300	mV	3
	Low Threshold	V_{TL}	-300	-100	mV	
LVDS Clock to Data Skew	t_{SKEW}	-	$ (0.2 * T_{clk})/7 $	ps	-	
LVDS Clock/DATA Rising/Falling time	t_{RF}	260	$ (0.3 * T_{clk})/7 $	ps	2	
Effective time of LVDS	t_{eff}	$ \pm 360 $	-	ps	-	
LVDS Clock to Clock Skew (Even to Odd)	t_{SKEW_EO}	-	$ 1/7 * T_{clk} $	ps	-	

- Note
1. All Input levels of LVDS signals are based on the EIA 644 Standard.
 2. If t_{RF} isn't enough, t_{eff} should be meet the range.
 3. LVDS Differential Voltage is defined within t_{eff}

LC370EUN

Product Specification

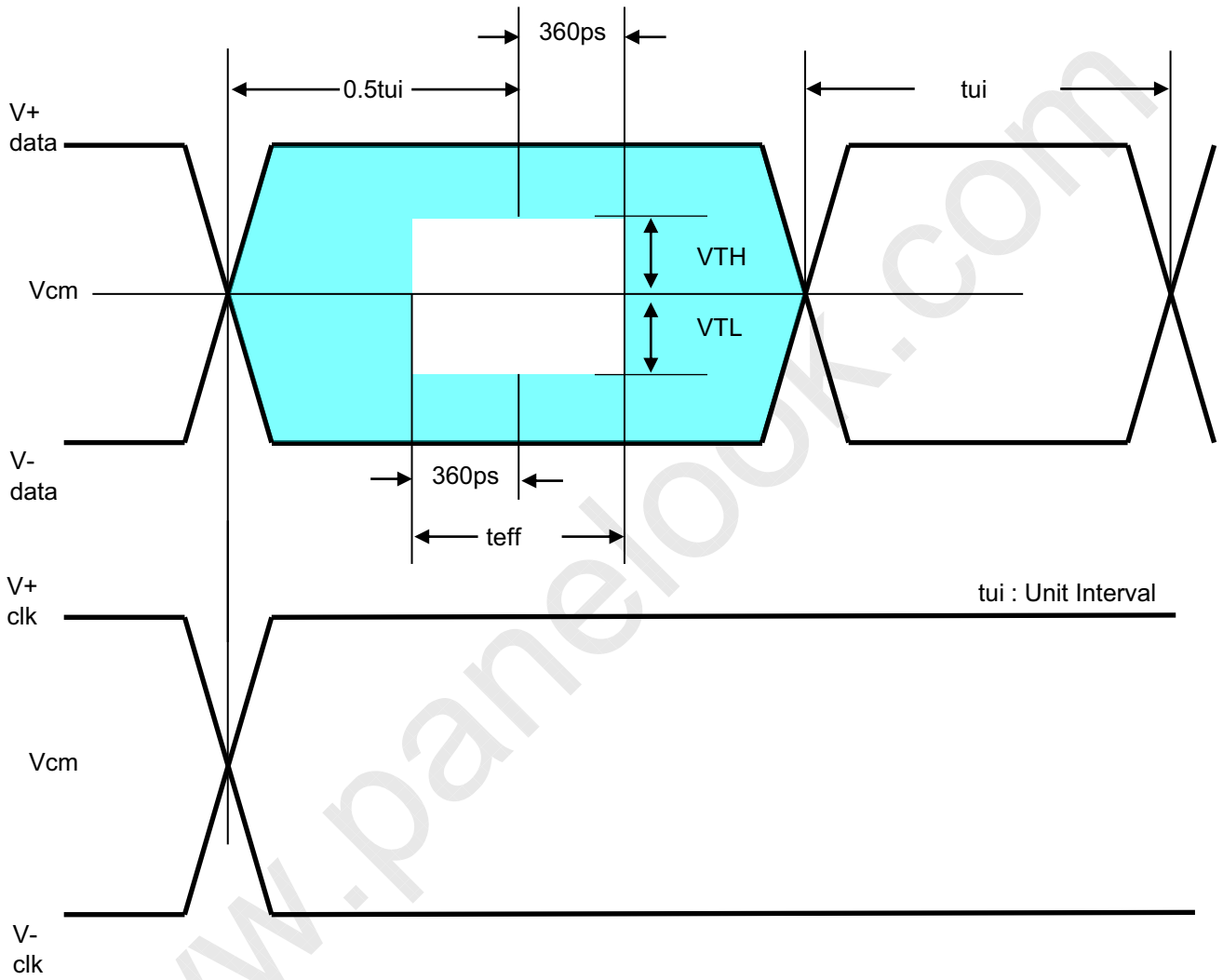

LC370EUN

Product Specification

3-5. Color Data Reference

The brightness of each primary color(red,green,blue) is based on the 8bit gray scale data input for the color. The higher binary input, the brighter the color. Table 7 provides a reference for color versus data input.

Table 7. COLOR DATA REFERENCE

Color		Input Color Data																							
		RED								GREEN								BLUE							
		MSB	LSB						MSB	LSB						MSB	LSB								
		R7	R6	R5	R4	R3	R2	R1	R0	G7	G6	G5	G4	G3	G2	G1	G0	B7	B6	B5	B4	B3	B2	B1	B0
Basic Color	Black	0	0	0	0	0	0	0	0	0	0	0	0	0	0	0	0	0	0	0	0	0	0	0	0
	Red (255)	1	1	1	1	1	1	1	1	0	0	0	0	0	0	0	0	0	0	0	0	0	0	0	0
	Green (255)	0	0	0	0	0	0	0	0	1	1	1	1	1	1	1	1	0	0	0	0	0	0	0	0
	Blue (255)	0	0	0	0	0	0	0	0	0	0	0	0	0	0	0	0	1	1	1	1	1	1	1	1
	Cyan	0	0	0	0	0	0	0	0	1	1	1	1	1	1	1	1	1	1	1	1	1	1	1	1
	Magenta	1	1	1	1	1	1	1	1	0	0	0	0	0	0	0	0	1	1	1	1	1	1	1	1
	Yellow	1	1	1	1	1	1	1	1	1	1	1	1	1	1	1	1	0	0	0	0	0	0	0	0
	White	1	1	1	1	1	1	1	1	1	1	1	1	1	1	1	1	1	1	1	1	1	1	1	1
RED	RED (000)	0	0	0	0	0	0	0	0	0	0	0	0	0	0	0	0	0	0	0	0	0	0	0	0
	RED (001)	0	0	0	0	0	0	0	1	0	0	0	0	0	0	0	0	0	0	0	0	0	0	0	0
							
	RED (254)	1	1	1	1	1	1	1	0	0	0	0	0	0	0	0	0	0	0	0	0	0	0	0	0
	RED (255)	1	1	1	1	1	1	1	1	0	0	0	0	0	0	0	0	0	0	0	0	0	0	0	0
GREEN	GREEN (000)	0	0	0	0	0	0	0	0	0	0	0	0	0	0	0	0	0	0	0	0	0	0	0	0
	GREEN (001)	0	0	0	0	0	0	0	0	0	0	0	0	0	0	0	1	0	0	0	0	0	0	0	0
							
	GREEN (254)	0	0	0	0	0	0	0	0	1	1	1	1	1	1	1	0	0	0	0	0	0	0	0	0
	GREEN (255)	0	0	0	0	0	0	0	0	1	1	1	1	1	1	1	1	0	0	0	0	0	0	0	0
BLUE	BLUE (000)	0	0	0	0	0	0	0	0	0	0	0	0	0	0	0	0	0	0	0	0	0	0	0	0
	BLUE (001)	0	0	0	0	0	0	0	0	0	0	0	0	0	0	0	0	0	0	0	0	0	0	0	1
							
	BLUE (254)	0	0	0	0	0	0	0	0	0	0	0	0	0	0	0	0	1	1	1	1	1	1	1	0
	BLUE (255)	0	0	0	0	0	0	0	0	0	0	0	0	0	0	0	0	1	1	1	1	1	1	1	1

LC370EUN

Product Specification

3-6. Power Sequence

3-6-1. LCD Driving circuit

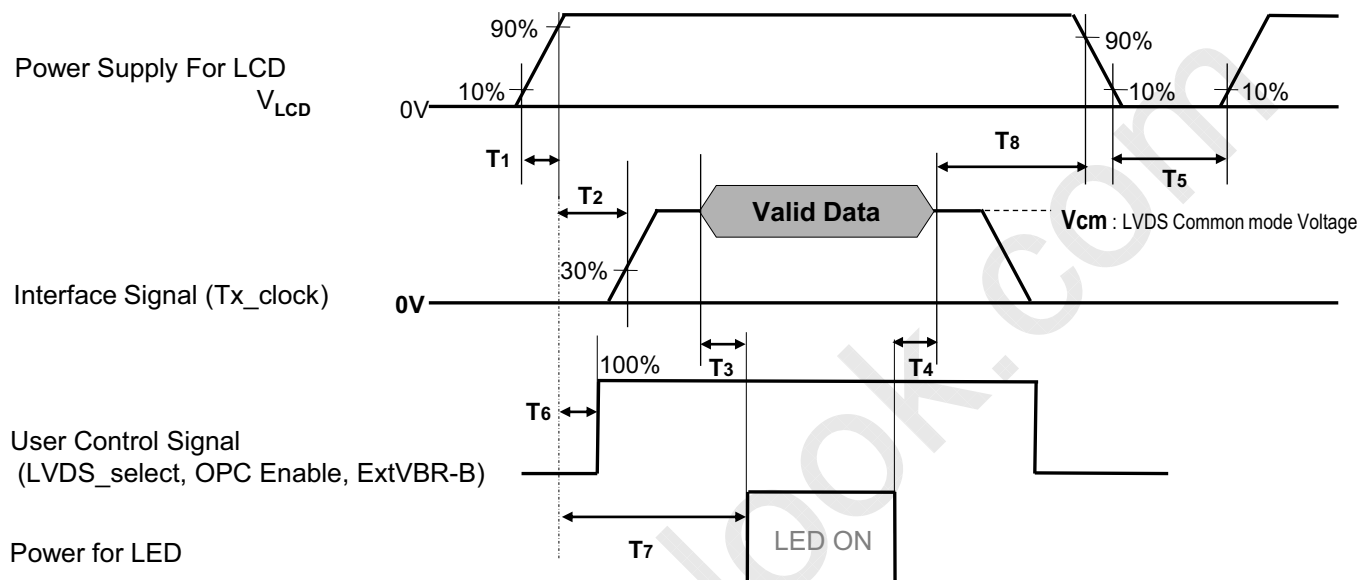

Table 8. POWER SEQUENCE

Parameter	Value			Unit	Notes
	Min	Typ	Max		
T1	0.5	-	20	ms	1
T2	0	-	-	ms	2
T3	200	-	-	ms	3
T4	200	-	-	ms	3
T5	1.0	-	-	s	4
T6	-	-	T2	ms	5
T7	0.5	-	-	s	6
T8	100	-	-	ms	7

- Note :
1. Even though T1 is over the specified value, there is no problem if I2T spec of fuse is satisfied.
 2. If T2 is satisfied with specification after removing LVDS Cable, there is no problem.
 3. The T3 / T4 is recommended value, the case when failed to meet a minimum specification, abnormal display would be shown. There is no reliability problem.
 4. T5 should be measured after the Module has been fully discharged between power off and on period.
 5. If the on time of signals (Interface signal and user control signals) precedes the on time of Power (V_{LCD}), it will be happened abnormal display. When T6 is NC status, T6 doesn't need to be measured.
 6. If there is no abnormal display, no problem.
 7. It is recommendation specification that T8 has to be 100ms as a minimum value.
- ※ Please avoid floating state of interface signal at invalid period.
 ※ When the power supply for LCD (V_{LCD}) is off, be sure to pull down the valid and invalid data to 0V.

LC370EUN

Product Specification

3-6-2. Sequence for LED Driver

Power Supply For LED Driver

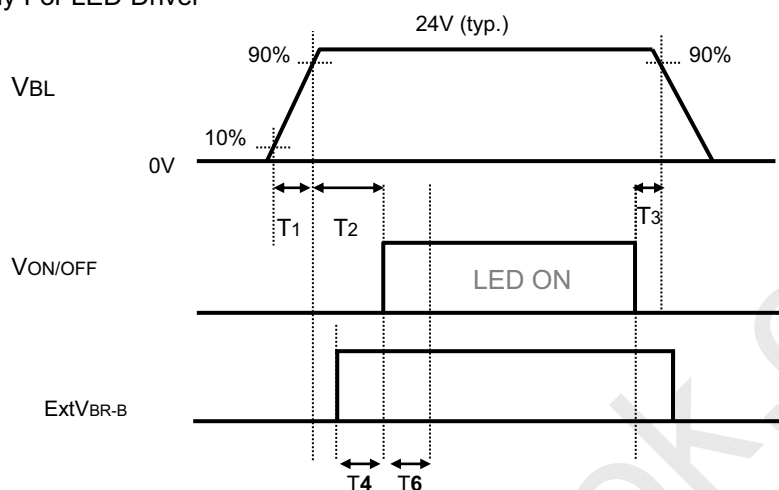

3-6-3. Dip condition for LED Driver

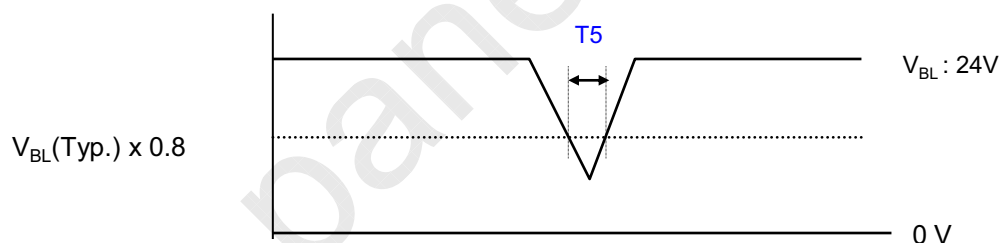

Table 9. Power Sequence for LED Driver

Parameter	Values			Units	Remarks
	Min	Typ	Max		
T1	20	-	-	ms	1
T2	500	-	-	ms	
T3	10	-	-	ms	
T4	0	-	-	ms	
T5	-	-	10	ms	$V_{BL}(Typ) \times 0.8$
T6	500	-	-	ms	2

Notes : 1. T1 describes rising time of 0V to 24V and this parameter does not applied at restarting time.

Even though T1 is over the specified value, there is no problem if I²T spec of fuse is satisfied.

2. In T6 section, ExtVBR-B should be sustained from 5% to 100% .

LC370EUN

Product Specification

4. Optical Specification

Optical characteristics are determined after the unit has been 'ON' and stable in a dark environment at $25\pm 2^\circ\text{C}$. The values are specified at 50cm from the LCD surface at a viewing angle of Φ and θ equal to 0° . FIG. 1 shows additional information concerning the measurement equipment and method.

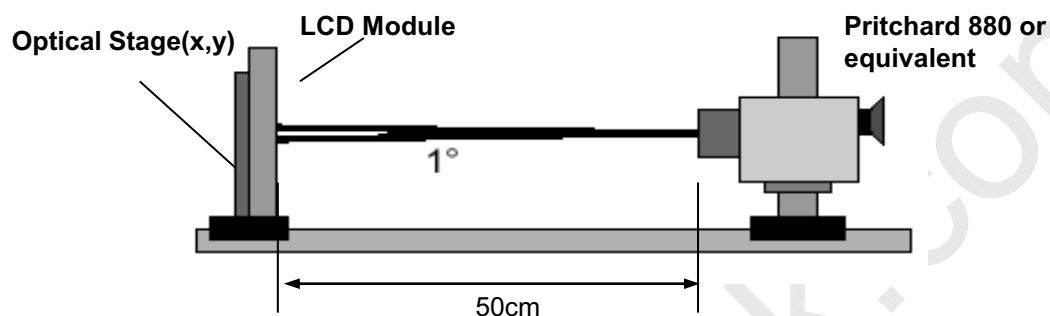

FIG. 1 Optical Characteristic Measurement Equipment and Method

 $T_a = 25\pm 2^\circ\text{C}$, $V_{\text{LCD}} = 12.0\text{V}$, $f_v = 60\text{Hz}$, $D_{\text{clk}} = 74.25\text{MHz}$,
EXTV_{BR-B} = 100%

Table 10. OPTICAL CHARACTERISTICS

Parameter	Symbol	Value			Unit	Note		
		Min	Typ	Max				
Contrast Ratio	CR	1000	1400	-		1		
Surface Luminance, white	L _{WH}	2D	290	360	-	cd/m ²	2	
		3D	110	135				
Luminance Variation	δ_{WHITE}	5P	-	-	1.3		3	
Response Time	Variation	G to G _{σ}	-	6	9		5	
	Gray to Gray (BW)	G to G _{BW}	-	8	12	ms	4	
Color Coordinates [CIE1931]	RED	R _x		TBD		Typ -0.03	Typ +0.03	
		R _y		TBD				
	GREEN	G _x		TBD				
		G _y		TBD				
	BLUE	B _x		TBD				
		B _y		TBD				
	WHITE	W _x		0.279				
W _y			0.292					
Color Temperature			10,000		K			
Color Gamut			68		%			
Viewing Angle	2D (CR>10)	x axis, right($\phi=0^\circ$)	θ_r	89	-	-	degree	6
		x axis, left ($\phi=180^\circ$)	θ_l	89	-	-		
		y axis, up ($\phi=90^\circ$)	θ_u	89	-	-		
		y axis, down ($\phi=270^\circ$)	θ_d	89	-	-		
	3D (CT \leq 10%)	up + down	θ_u (y axis) + θ_d (y axis)	12			degree	8
Gray Scale			-	-	-		7	

Ver. 0.1

17 / 30

Product Specification

Note : 1. Contrast Ratio(CR) is defined mathematically as :

$$\text{Contrast Ratio} = \frac{\text{Surface Luminance with all white pixels}}{\text{Surface Luminance with all black pixels}}$$

It is measured at center 1-point.

2. Surface luminance are determined after the unit has been 'ON' and 1 Hour after lighting the backlight in a dark environment at $25 \pm 2^\circ\text{C}$. Surface luminance is the luminance value at center 1-point across the LCD surface 50cm from the surface with all pixels displaying white. For more information see the FIG. 2.
3. The variation in surface luminance, δ WHITE is defined as :
 δ WHITE(5P) = Maximum($L_{on1}, L_{on2}, L_{on3}, L_{on4}, L_{on5}$) / Minimum($L_{on1}, L_{on2}, L_{on3}, L_{on4}, L_{on5}$)
 Where L_{on1} to L_{on5} are the luminance with all pixels displaying white at 5 locations . For more information, see the FIG. 2.
4. Response time is the time required for the display to transit from any gray to white (Rise Time, Tr_R) and from any gray to black (Decay time, Tr_D). For additional information see the FIG. 3.
 ※ G to G_{BW} Spec stands for average value of all measured points.
 Photo Detector : RD-80S / Field : 2°
5. G to G_σ is Variation of Gray to Gray response time composing a picture

$$G \text{ to } G(\sigma) = \sqrt{\frac{\sum(X_i - u)^2}{N}}$$

X_i = Individual Data
 u = Data average
 N : The number of Data

6. Viewing angle is the angle at which the contrast ratio is greater than 10. The angles are determined for the horizontal or x axis and the vertical or y axis with respect to the z axis which is normal to the LCD module surface. For more information, see the FIG. 4.
7. Gray scale specification
 Gamma Value is approximately 2.2. For more information, see the Table 11.
8. 3D performance specification is expressed by 3D luminance and 3D viewing angle.

Table 11. GRAY SCALE SPECIFICATION

Gray Level	Luminance [%] (Typ)
L0	0.07
L15	0.27
L31	1.04
L47	2.49
L63	4.68
L79	7.66
L95	11.5
L111	16.1
L127	21.6
L143	28.1
L159	35.4
L175	43.7
L191	53.0
L207	63.2
L223	74.5
L239	86.7
L255	100

LC370EUN

Product Specification

Measuring point for surface luminance & measuring point for luminance variation.

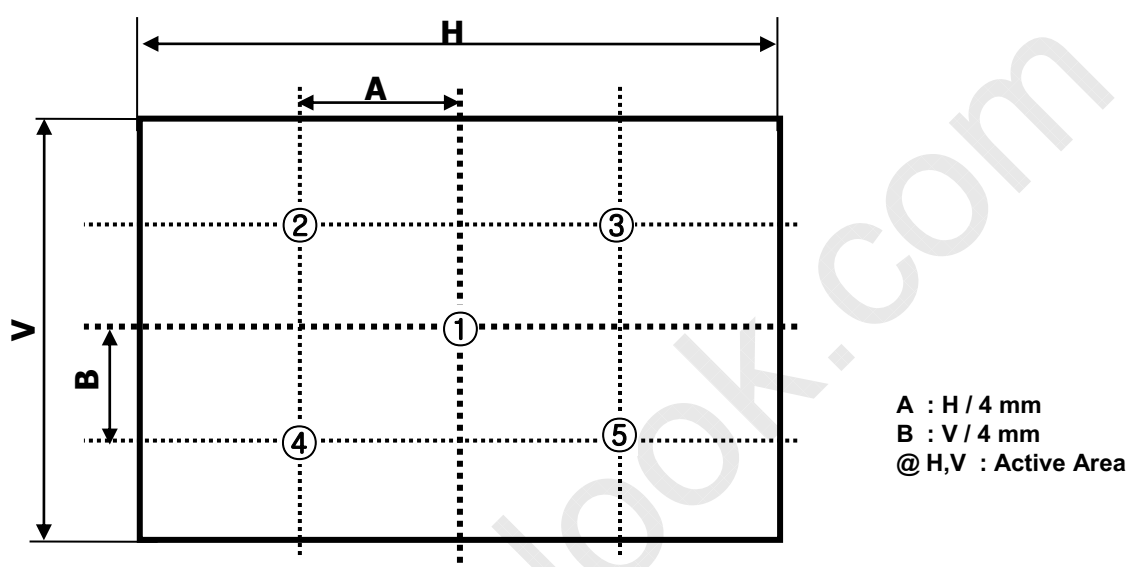

FIG. 2 5 Points for Luminance Measure

Response time is defined as the following figure and shall be measured by switching the input signal for "Gray(N)" and "Black or White".

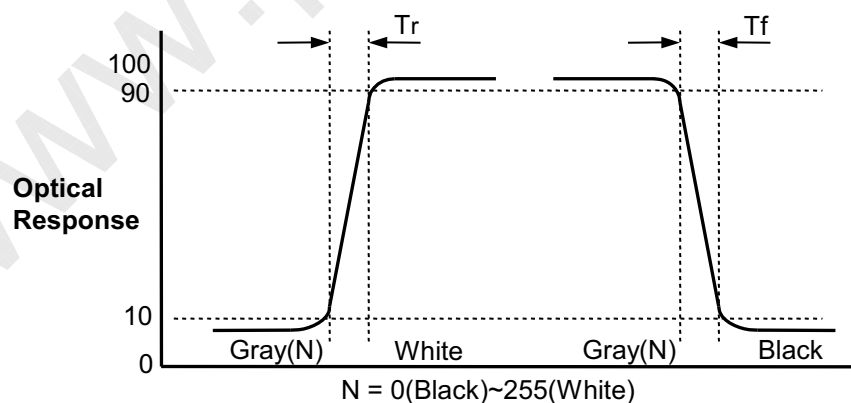

FIG. 3 Response Time

LC370EUN

Product Specification

Dimension of viewing angle range

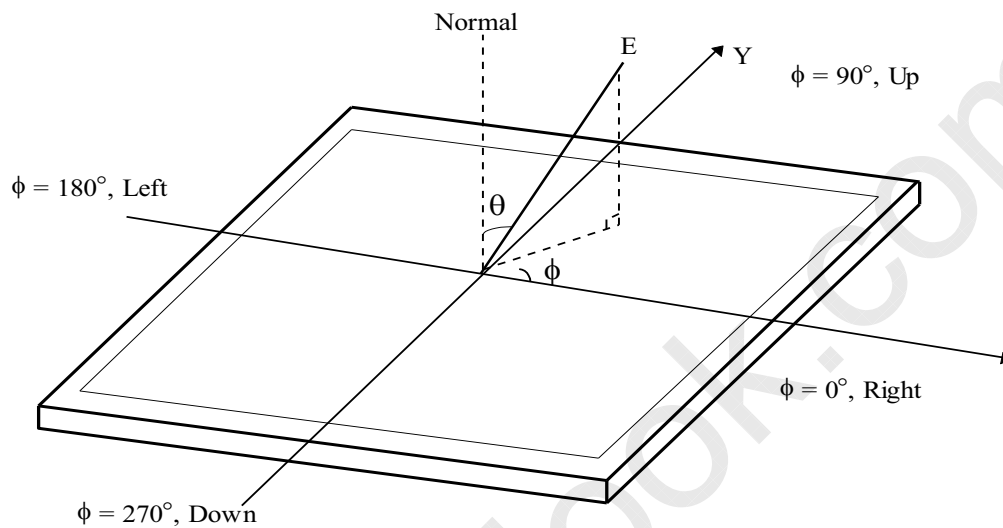
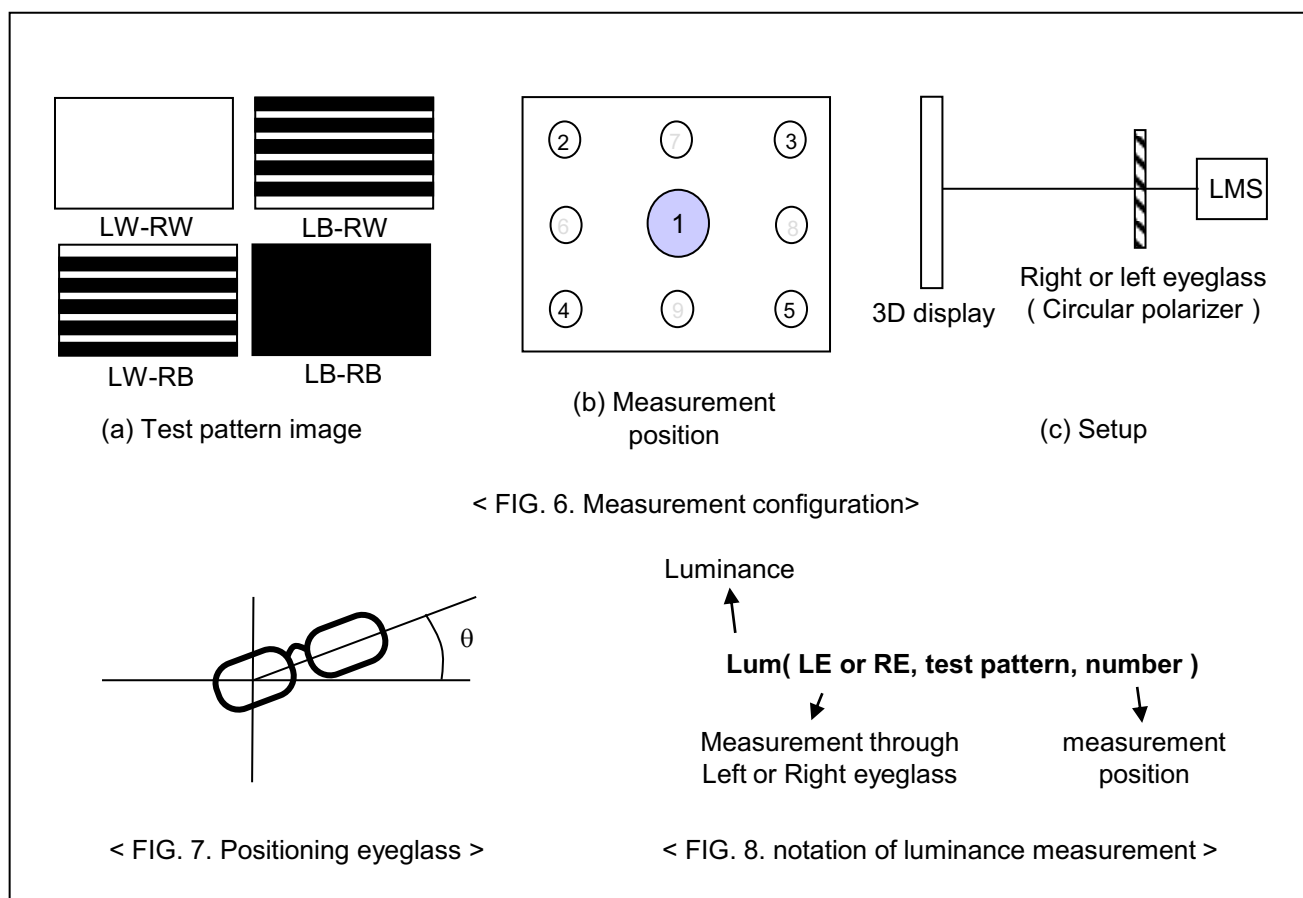

FIG. 4 Viewing Angle

Product Specification



In order to measure 3D luminance, 3D crosstalk and 3D viewing angle, it need to be prepared as below;

1) Measurement configuration

4-Test pattern images. Refer to FIG 6.

- LW-RW : White for left and right eye
- LW-RB : White for left eye and Black for right eye
- LB-RW : Black for left eye and white for right eye
- LB-RB : Black for left eye and right eye

Image files where black and white lines are displayed on even or odd lines.

Luminance measurement system (LMS) with narrow FOV (field of view) is used. Refer to FIG 1.

2) Positioning Eyeglass (refer to appendix-VII for standard specification of eyeglass)

Find angle of minimum transmittance.

This value would be provided beforehand or measured by the following steps;

- (i) Test image (LB-RW) is displayed.
- (ii) Left eyeglass are placed in front of LMS and luminance is measured, rotating right eyeglass such as FIG 7. The notation for luminance measurement is "Lum(LE, LB-RW, 1)".
- (iii) Find the angle where luminance is minimum.

* Following measurements should be performed at the angle of minimum transmittance of eyeglass.

Product Specification

3) Measurement of 3D luminance

- (i) Test image (LW-RW) is displayed.
- (ii) Left or right eyeglass are placed in front of LMS successively and luminance is measured at center 1 point where the notation for luminance measurement is "Lum(LE, LW-RW,1)" or "Lum(RE, LW-RW,1).

4) Measurement of 3D crosstalk

- (i) Test image (LB-RW, LW-RB and LB-RB) is displayed.
- (ii) Right or left eyeglass are placed in front of LMS successively and luminance is measured for position 1. with rotating LMS or sample vertically.

$$\frac{\text{Lum(LE, LB-RW,1)} - \text{Lum(LE, LB-RB,1)}}{\text{Lum(LE, LW-RB,1)} - \text{Lum(LE, LB-RB,1)}}$$

or

$$\frac{\text{Lum(RE, LW-RB,1)} - \text{Lum(RE, LB-RB,1)}}{\text{Lum(RE, LB-RW,1)} - \text{Lum(RE, LB-RB,1)}}$$

5) Measurement of 3D Viewing Angle

3D viewing angle is the angle at which the 3D crosstalk is under 10%. The angles are determined for the vertical or y axis with respect to the z axis which is normal to the LCD module surface and measured for position 1. For more information , see the Fig 9

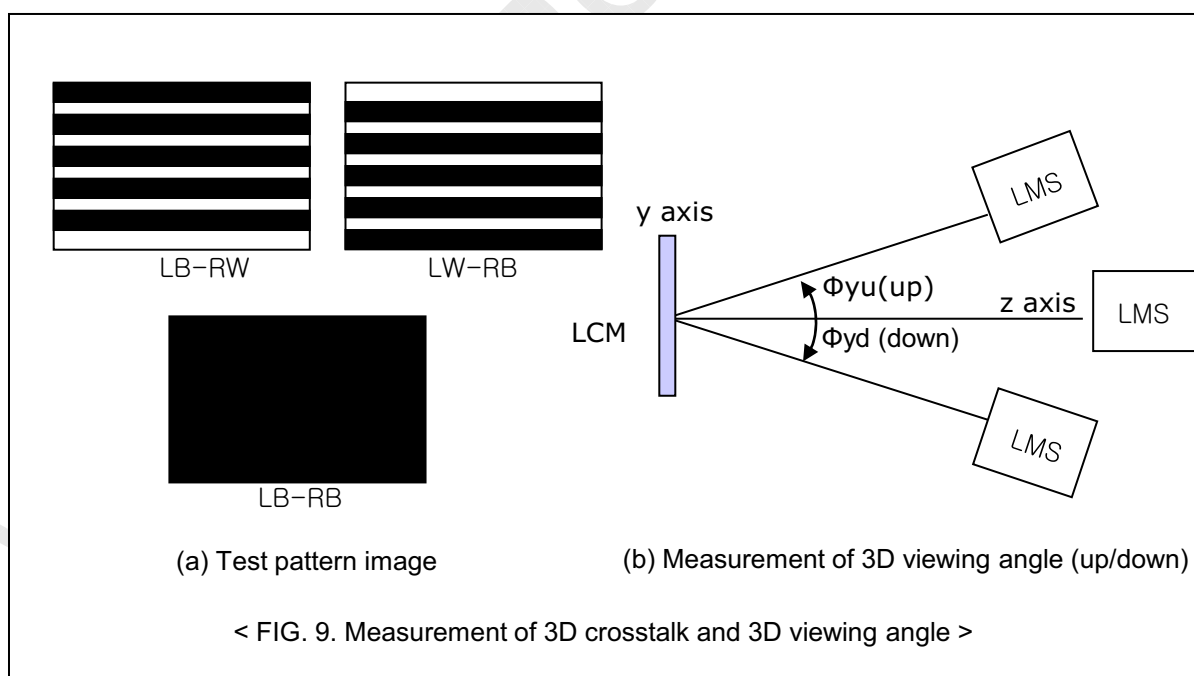

LC370EUN

Product Specification

5. Mechanical Characteristics

Table 12 provides general mechanical characteristics.

Table 12. MECHANICAL CHARACTERISTICS

Item	Value	
Outline Dimension	Horizontal	837.2 mm
	Vertical	490.6 mm
	Depth	22.7 mm
Bezel Area	Horizontal	815.4 mm
	Vertical	461.7 mm
Active Display Area	Horizontal	808.128 mm
	Vertical	454.572 mm
Weight	7.5 Kg (Typ.), 7.9 kg (Max.)	

Note : Please refer to a mechanical drawing in terms of tolerance at the next page.

LC370EUN

Product Specification

[FRONT VIEW]

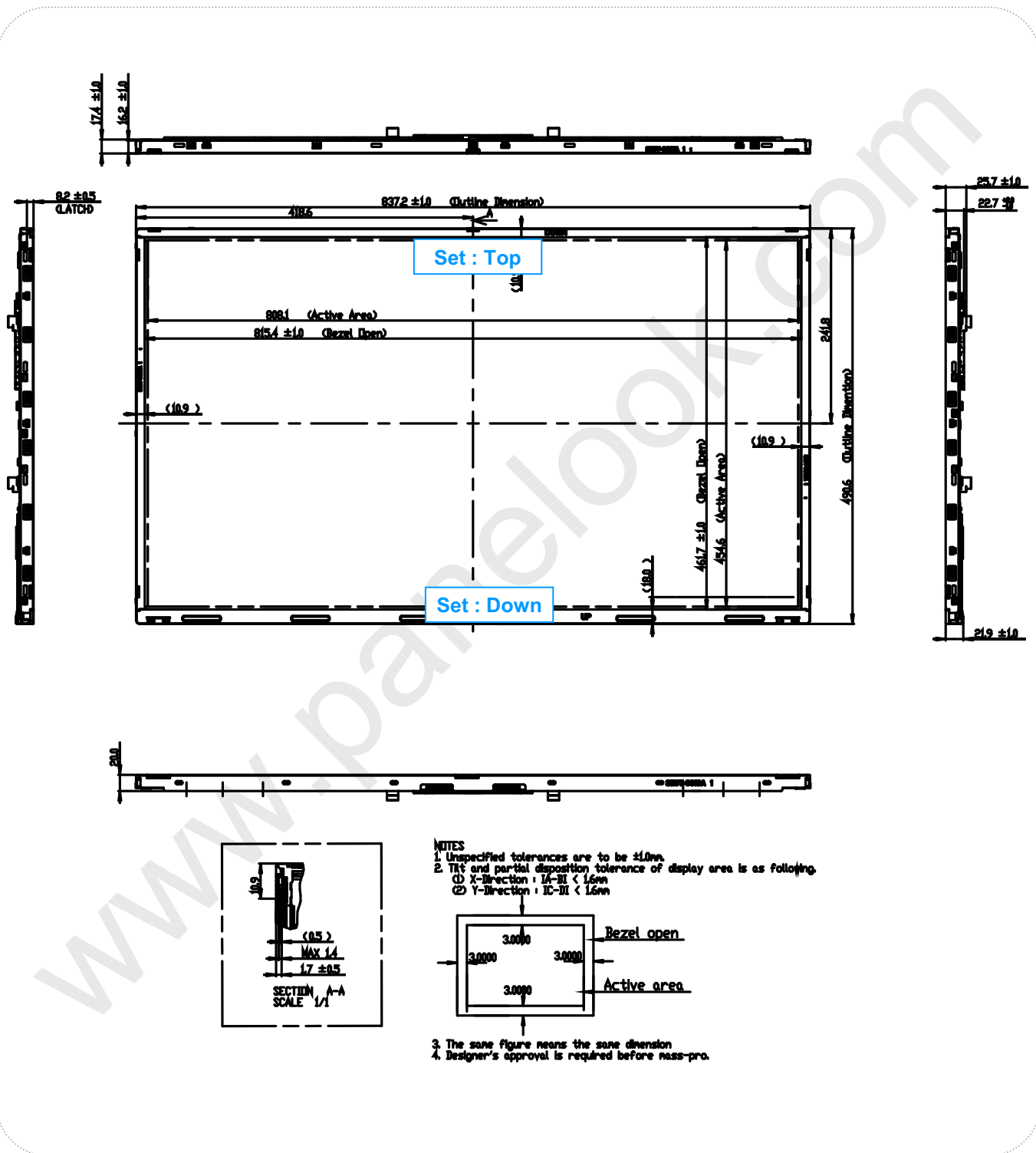

Ver. 0.1

LC370EUN

Product Specification

[REAR VIEW]

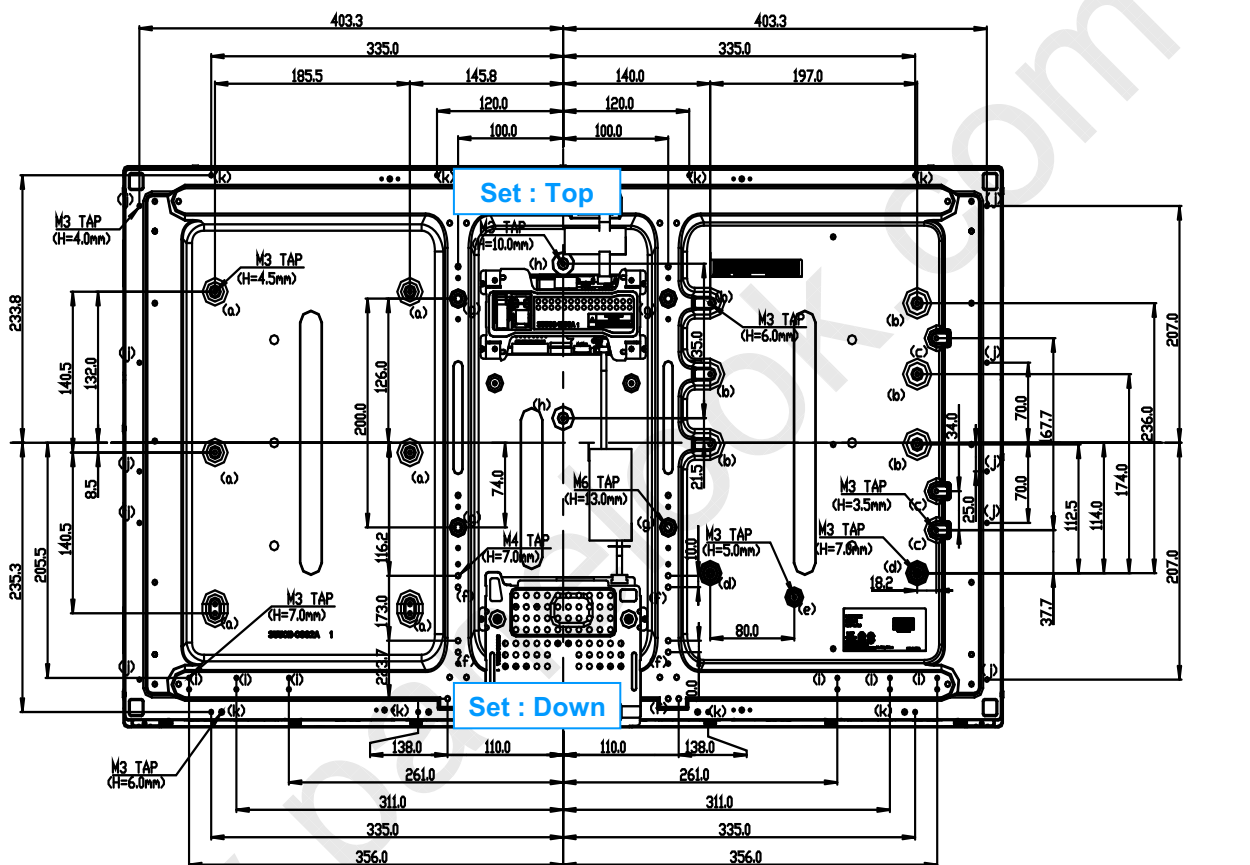

ITEM	TAP	Max Depth (mm)	Torque (KgF.cm)	Notes
(a)	M3	4.5	Max 8.0	
(b)	M3	6.0	Max 8.0	
(c)	M3	3.5	Max 8.0	
(d)	M3	7.0	Max 8.0	
(e)	M3	5.0	Max 8.0	
(f)	M4	7.0	Max 10.0	
(g)	M6	13.0	Max 15.0	
(h)	M3	10.0	Max 8.0	
(i)	M3	7.0	Max 8.0	
(j)	M3	4.0	Max 8.0	
(k)	M3	6.0	Max 8.0	

Ver. 0.1

LC370EUN

Product Specification

6. Reliability**Table 13. ENVIRONMENT TEST CONDITION**

No.	Test Item	Condition
1	High temperature storage test	Ta= 60°C 240h
2	Low temperature storage test	Ta= -20°C 240h
3	High temperature operation test	Ta= 50°C 50%RH 240h
4	Low temperature operation test	Ta= 0°C 240h
5	Vibration test (non-operating)	Wave form : random Vibration level : 1.0Grms Bandwidth : 10-300Hz Duration : X,Y,Z, Each direction per 10 min
6	Shock test (non-operating)	Shock level : 50Grms Waveform : half sine wave, 11ms Direction : ±X, ±Y, ±Z One time each direction
7	Humidity condition Operation	Ta= 40 °C ,90%RH
8	Altitude operating storage / shipment	0 - 15,000 ft 0 - 40,000 ft

Note : Before and after Reliability test, LCM should be operated with normal function.

Product Specification

7. International Standards

7-1. Safety

- a) UL 60065, Seventh Edition, Underwriters Laboratories Inc.
Audio, Video and Similar Electronic Apparatus - Safety Requirements.
- b) CAN/CSA C22.2 No.60065:03, Canadian Standards Association.
Audio, Video and Similar Electronic Apparatus - Safety Requirements.
- c) EN 60065:2002 + A11:2008, European Committee for Electrotechnical Standardization (CENELEC).
Audio, Video and Similar Electronic Apparatus - Safety Requirements.
- d) IEC 60065:2005 + A1:2005, The International Electrotechnical Commission (IEC).
Audio, Video and Similar Electronic Apparatus - Safety Requirements.
(Including report of IEC60825-1:2001 clause 8 and clause 9)

Notes

1. Laser (LED Backlight) Information

Class 1M LED Product IEC60825-1 : 2001 Embedded LED Power (Class 1M)
--

2. Caution

: LED inside.
Class 1M laser (LEDs) radiation when open.
Do not open while operating.

7-2. EMC

- a) ANSI C63.4 "American National Standard for Methods of Measurement of Radio-Noise Emissions from Low-Voltage Electrical and Electronic Equipment in the Range of 9 kHz to 40 GHz." American National Standards Institute (ANSI), 2003.
- b) CISPR 22 "Information technology equipment – Radio disturbance characteristics – Limit and methods of measurement." International Special Committee on Radio Interference (CISPR), 2005.
- c) CISPR 13 "Sound and television broadcast receivers and associated equipment – Radio disturbance characteristics – Limits and method of measurement." International Special Committee on Radio Interference (CISPR), 2006.

7-3. Environment

- a) RoHS, Directive 2002/95/EC of the European Parliament and of the council of 27 January 2003

LC370EUN

Product Specification

8. Packing**8-1. Information of LCM Label**

a) Lot Mark

A	B	C	D	E	F	G	H	I	J	K	L	M
---	---	---	---	---	---	---	---	---	---	---	---	---

A,B,C : SIZE(INCH)
E : MONTH

D : YEAR
F ~ M : SERIAL NO.

Note

1. YEAR

Year	2011	2012	2013	2014	2015	2016	2017	2018	2019	2020
Mark	A	B	C	D	E	F	G	H	J	K

2. MONTH

Month	Jan	Feb	Mar	Apr	May	Jun	Jul	Aug	Sep	Oct	Nov	Dec
Mark	1	2	3	4	5	6	7	8	9	A	B	C

b) Location of Lot Mark

Serial NO. is printed on the label. The label is attached to the backside of the LCD module.
This is subject to change without prior notice.

8-2. Packing Form

a) Package quantity in one Pallet : 18 pcs

b) Pallet Size : 1140 mm(W) X 990mm(D) X 700 mm(H)

Product Specification

9. Precautions

Please pay attention to the followings when you use this TFT LCD module.

9-1. Mounting Precautions

- (1) You must mount a module using specified mounting holes (Details refer to the drawings).
- (2) You should consider the mounting structure so that uneven force (ex. Twisted stress) is not applied to the module. And the case on which a module is mounted should have sufficient strength so that external force is not transmitted directly to the module.
- (3) Please attach the surface transparent protective plate to the surface in order to protect the polarizer. Transparent protective plate should have sufficient strength in order to resist external force.
- (4) You should adopt radiation structure to satisfy the temperature specification.
- (5) Acetic acid type and chlorine type materials for the cover case are not desirable because the former generates corrosive gas of attacking the polarizer at high temperature and the latter causes circuit break by electro-chemical reaction.
- (6) Do not touch, push or rub the exposed polarizers with glass, tweezers or anything harder than HB pencil lead. And please do not rub with dust clothes with chemical treatment. Do not touch the surface of polarizer for bare hand or greasy cloth. (Some cosmetics are detrimental to the polarizer.)
- (7) When the surface becomes dusty, please wipe gently with absorbent cotton or other soft materials like chamois soaks with petroleum benzine. Normal-hexane is recommended for cleaning the adhesives used to attach front / rear polarizers. Do not use acetone, toluene and alcohol because they cause chemical damage to the polarizer.
- (8) Wipe off saliva or water drops as soon as possible. Their long time contact with polarizer causes deformations and color fading.
- (9) Do not open the case because inside circuits do not have sufficient strength.

9-2. Operating Precautions

- (1) Response time depends on the temperature. (In lower temperature, it becomes longer.)
- (2) Brightness depends on the temperature. (In lower temperature, it becomes lower.)
And in lower temperature, response time (required time that brightness is stable after turned on) becomes longer.
- (3) Be careful for condensation at sudden temperature change. Condensation makes damage to polarizer or electrical contacted parts. And after fading condensation, smear or spot will occur.
- (4) When fixed patterns are displayed for a long time, remnant image is likely to occur.
- (5) Module has high frequency circuits. Sufficient suppression to the electromagnetic interference shall be done by system manufacturers. Grounding and shielding methods may be important to minimize the interference.
- (6) Please do not give any mechanical and/or acoustical impact to LCM. Otherwise, LCM can't be operated its full characteristics perfectly.
- (7) A screw which is fastened up the steels should be a machine screw.
(if not, it can cause conductive particles and deal LCM a fatal blow)
- (8) Please do not set LCD on its edge.
- (9) The conductive material and signal cables are kept away from LED driver inductor to prevent abnormal display, sound noise and temperature rising.

Product Specification

9-3. Electrostatic Discharge Control

Since a module is composed of electronic circuits, it is not strong to electrostatic discharge. Make certain that treatment persons are connected to ground through wrist band etc. And don't touch interface pin directly.

9-4. Precautions for Strong Light Exposure

Strong light exposure causes degradation of polarizer and color filter.

9-5. Storage

When storing modules as spares for a long time, the following precautions are necessary.

- (1) Store them in a dark place. Do not expose the module to sunlight or fluorescent light. Keep the temperature between 5°C and 35°C at normal humidity.
- (2) The polarizer surface should not come in contact with any other object.
It is recommended that they be stored in the container in which they were shipped.
- (3) Storage condition is guaranteed under packing conditions.
- (4) The phase transition of Liquid Crystal in the condition of the low or high storage temperature will be recovered when the LCD module returns to the normal condition.

9-6. Handling Precautions for Protection Film

- (1) The protection film is attached to the bezel with a small masking tape.
When the protection film is peeled off, static electricity is generated between the film and polarizer. This should be peeled off slowly and carefully by people who are electrically grounded and with well ion-blown equipment or in such a condition, etc.
- (2) When the module with protection film attached is stored for a long time, sometimes there remains a very small amount of glue still on the bezel after the protection film is peeled off.
- (3) You can remove the glue easily. When the glue remains on the bezel surface or its vestige is recognized, please wipe them off with absorbent cotton waste or other soft material like chamois soaked with normal-hexane.

9-7. Operating condition guide

- (1) The LCD product should be operated under normal conditions. Normal condition is defined as below;
 - Temperature : 5 ~ 40 °C, normal humidity
 - Display pattern : continually changing pattern (Not stationary)
- (2) If the product will be used in extreme conditions such as high temperature, display patterns or operation time etc.,
It is strongly recommended to contact LGD for Qualification engineering advice. Otherwise, its reliability and function may not be guaranteed. Extreme conditions are commonly found at Airports, Transit Stations, Banks, Stock market, and Controlling systems. The LCD product should be applied by global standard environment. (refer ETSI EN 300, IEC 60721)

LC370EUN

Product Specification

APPENDIX-I

■ Pallet Ass'y

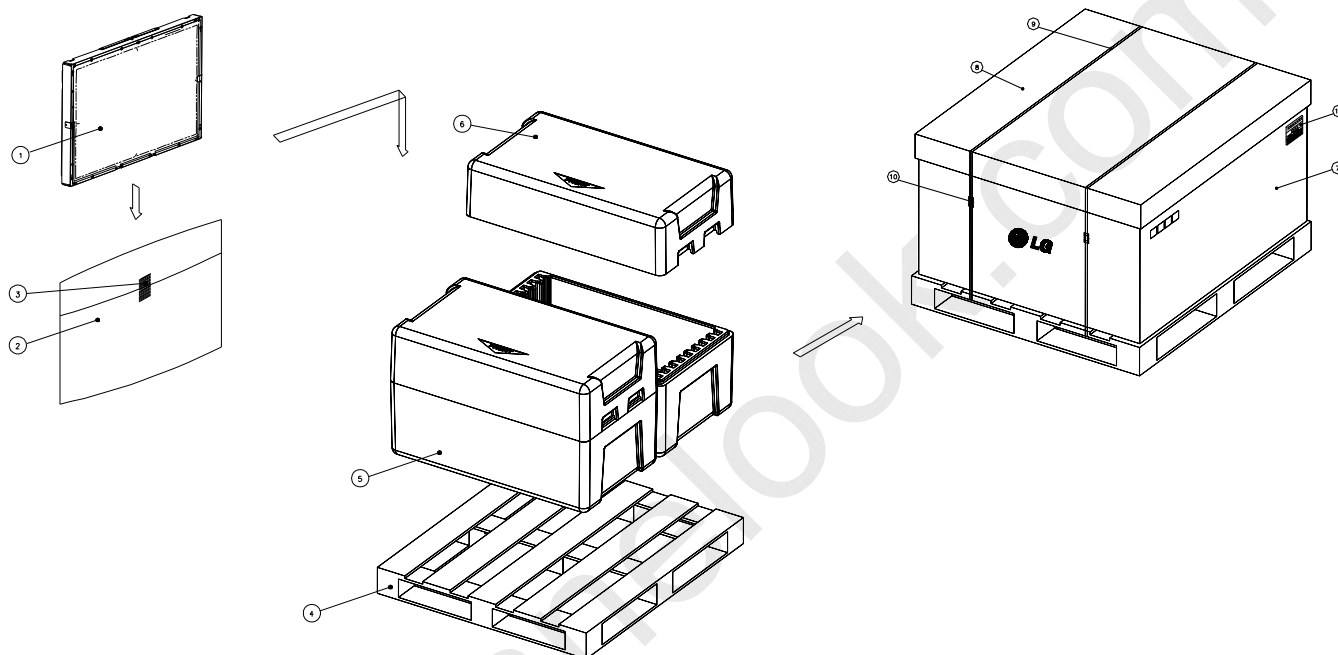

NO.	DESCRIPTION	MATERIAL
1	LCD Module	
2	BAG	37INCH
3	TAPE	MASKING 20MMX50M
4	PALLET	Plastic 1140X990X120mm
5	PACKING,BOTTOM	EPS
6	PACKING, TOP	EPS
7	ANGLE,PACKING	PAPER
8	BAND	PP
9	ANGLE,COVER	PAPER
10	BAND,CLIP	STEEL or PP
11	LABEL	YUPO 80G 100X70

Ver. 0.1

LC370EUN

Product Specification

APPENDIX- II-1

■ LCM Label

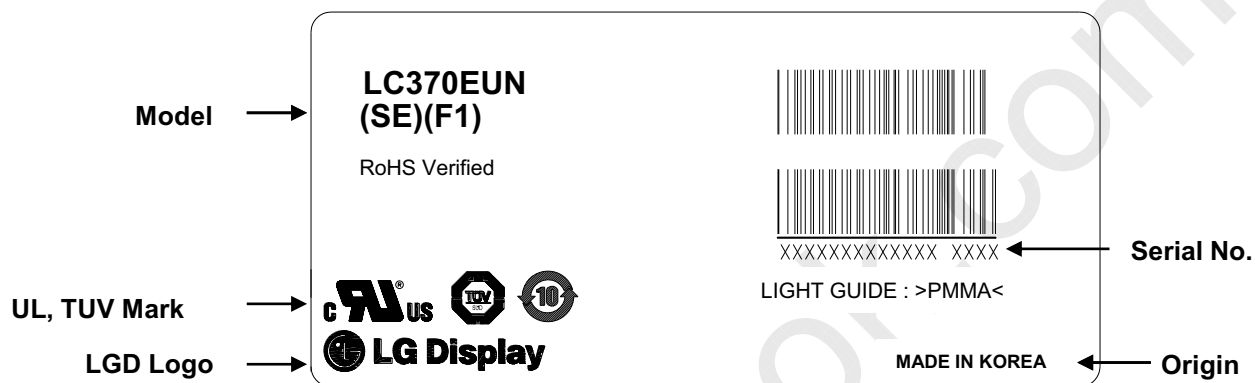

Ver. 0.1



LC370EUN

Product Specification

APPENDIX- II-2

■ Pallet Label

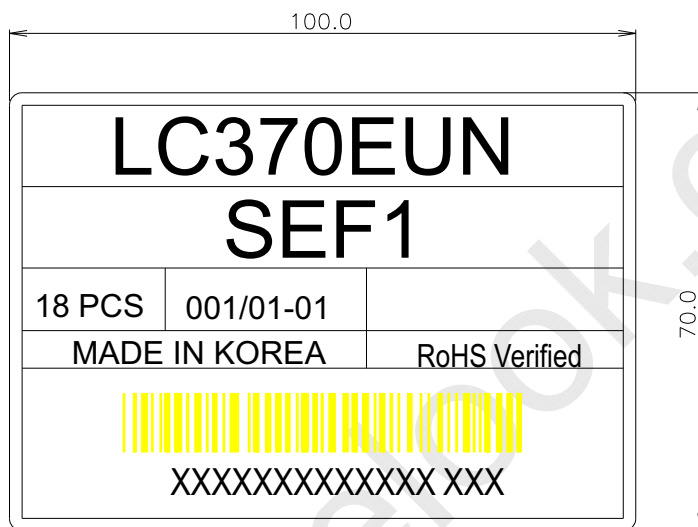

Ver. 0.1

LC370EUN

Product Specification

APPENDIX- III-1

■ Required signal assignment for Flat Link (Thine : THC63LVD103) Transmitter(Pin7= "L" or "NC")

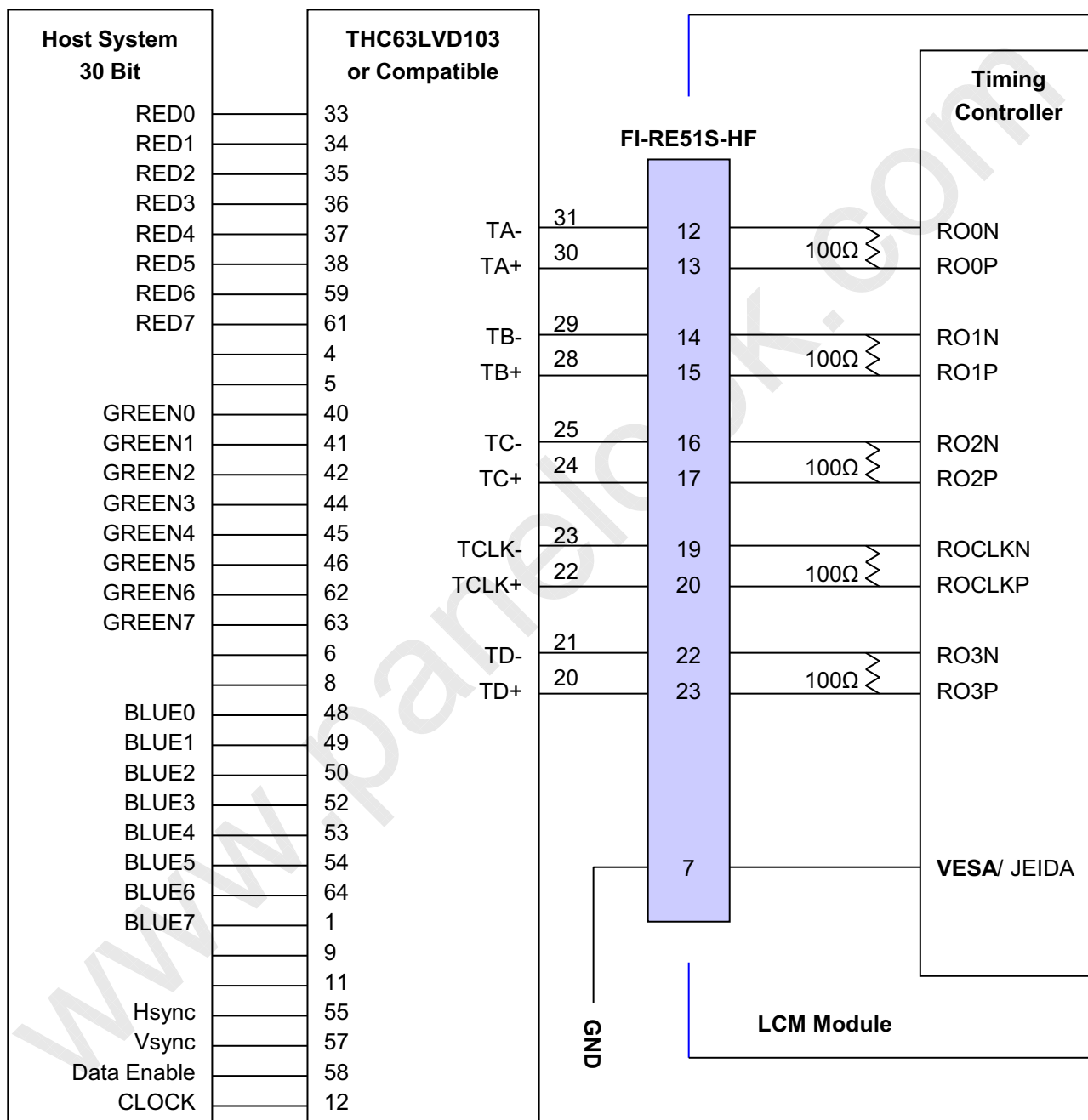

Note: 1. The LCD module uses a 100 Ohm[Ω] resistor between positive and negative lines of each receiver input.

2. Refer to LVDS Transmitter Data Sheet for detail descriptions. (THC63LVD103 or Compatible)

3. '7' means MSB and '0' means LSB at R,G,B pixel data.

Ver. 0.1

LC370EUN

Product Specification

APPENDIX- III-2

■ Required signal assignment for Flat Link (Thine : THC63LVD103) Transmitter(Pin7= "H")

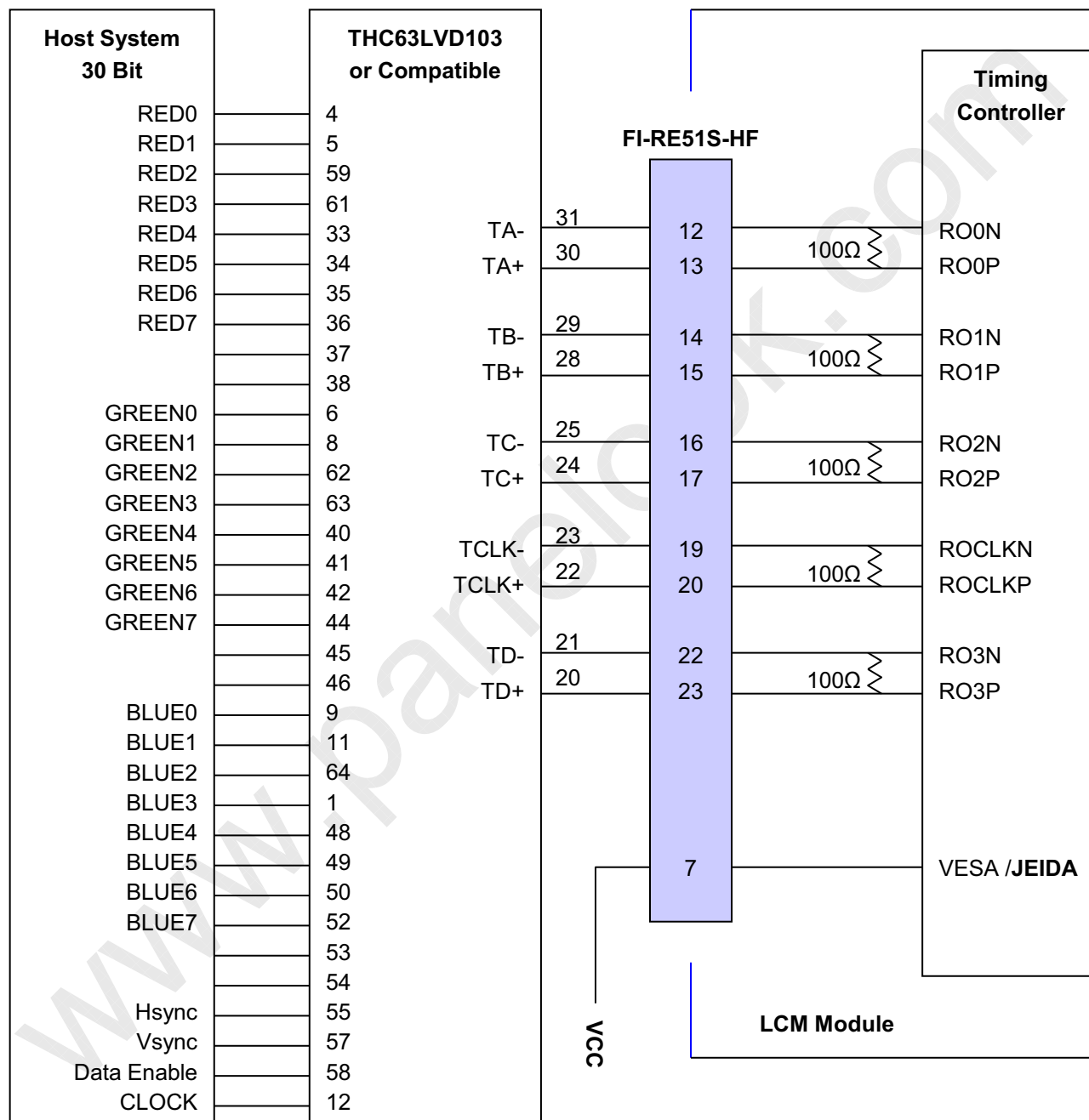

Note :1. The LCD module uses a 100 Ohm[Ω] resistor between positive and negative lines of each receiver input.

2. Refer to LVDS Transmitter Data Sheet for detail descriptions. (THC63LVD103 or Compatible)

3. '7' means MSB and '0' means LSB at R,G,B pixel data.

Ver. 0.1

Product Specification

APPENDIX- IV

■ LVDS Data-Mapping Information (8 Bit)

1) LVDS Select : "H" Data-Mapping (JEIDA format)

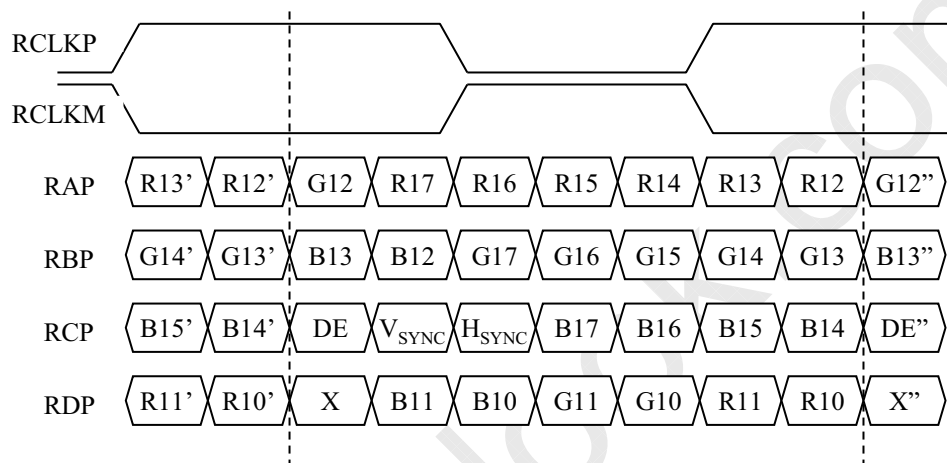

2) LVDS Select : "L" Data-Mapping (VESA format)

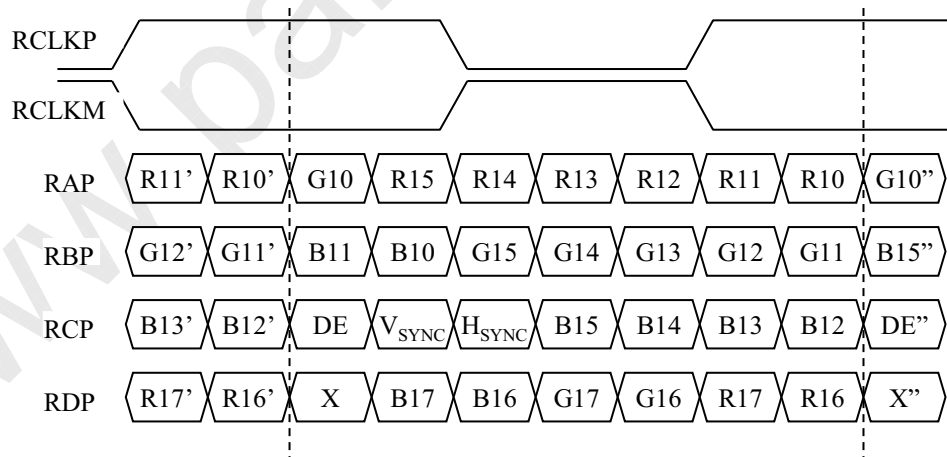

APPENDIX- V-1

■ Option Pin Circuit Block Diagram

1) Circuit Block Diagram of LVDS Format Selection pin

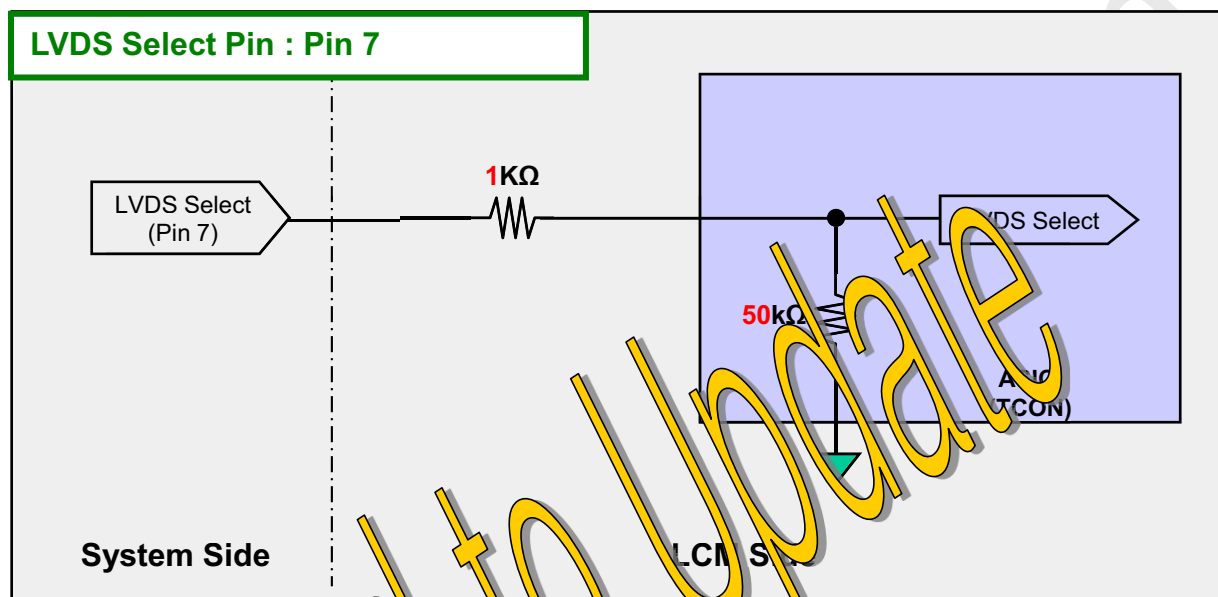

2) Circuit Block Diagram of OPC Enable Selection pin

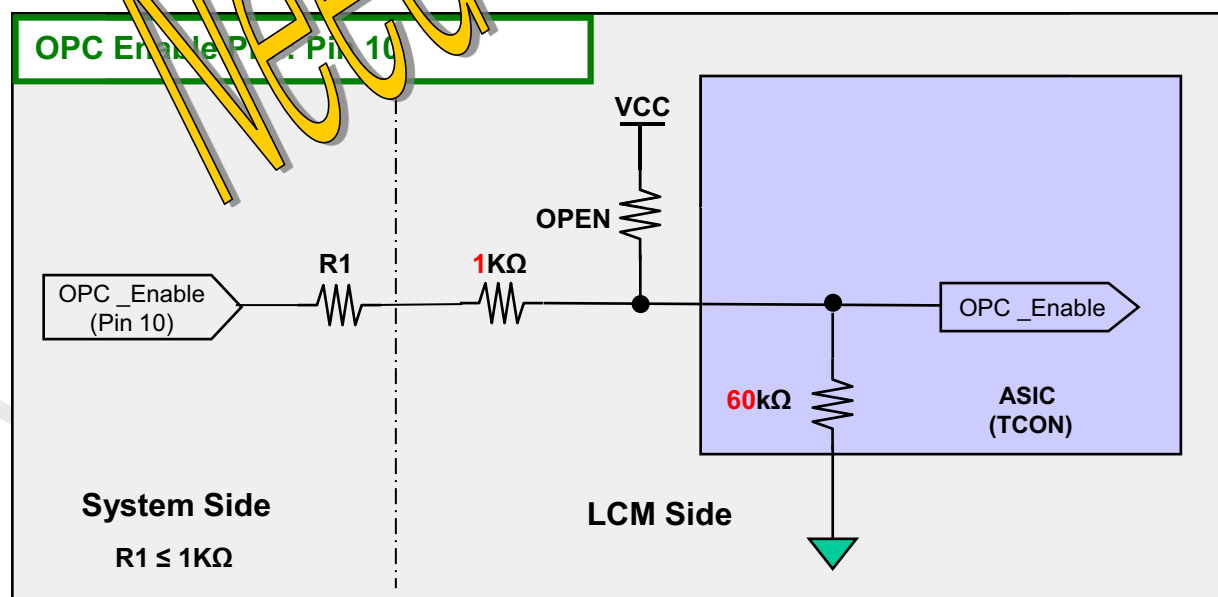

Product Specification

APPENDIX- VI

■ Scanning and OPC Design Guide

- ◇ When OPC Enable is "L", OPC Output = System Dimming.
OPC Output(PWM Signal) is synchronized with V-Sync Freq. of System in T-Con Board.

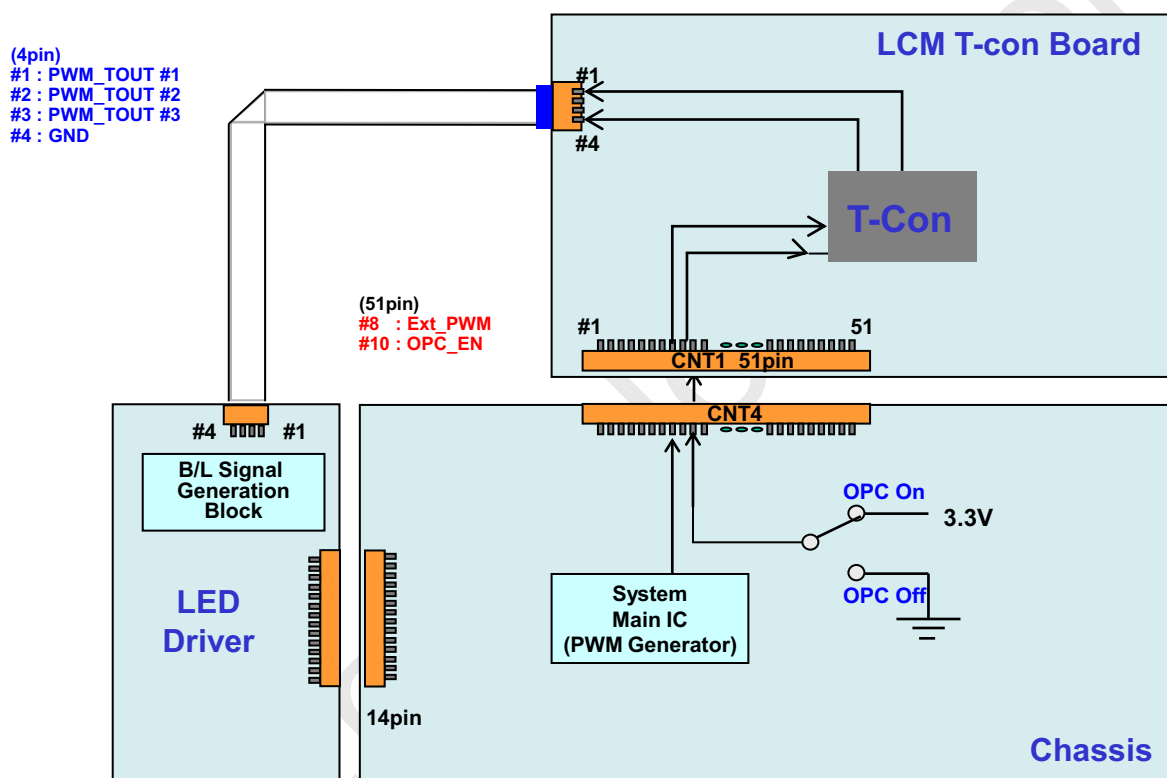

<With Driver Model>

- ◇ PWM Specification (VDD = 3.3V) @ OPC
 1. PWM High Voltage Range : 2.5V~3.6V
 2. PWM Low Voltage Range : 0.0V~0.8V

EXTV _{BR-B} Frequency	50 Hz for PAL 60 Hz for NTSC
Rising Time	MAX 10.0 μs
Falling Time	MAX 10.0 μs

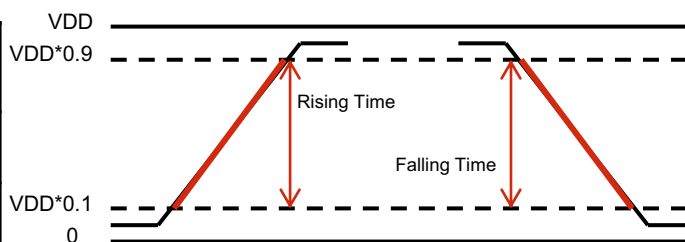

LC370EUN

Product Specification

APPENDIX- VII

■ Standard specification of Eyeglasses

This is recommended data of Eyeglasses for LC370EUN-SEF1 model. (details refer to table)

For each item, depending on the eyeglass manufacturer tolerances may occur, this tolerance can affect 3D performance. (3D Crosstalk, 3D luminance, 3D viewing angle)

<Table. Standard specification of Eyeglasses>

Design item of Eyeglasses		Left	Right	Remark
Optical axis	a) Slow axis of retarder	-45°	45°	Refer to drawing
	b) Transmission axis of polarizer	0°	0°	
Retardation value	Retarder	125nm		@550nm

※Recommended polarizer

Polarization efficiency: more than 99.90%

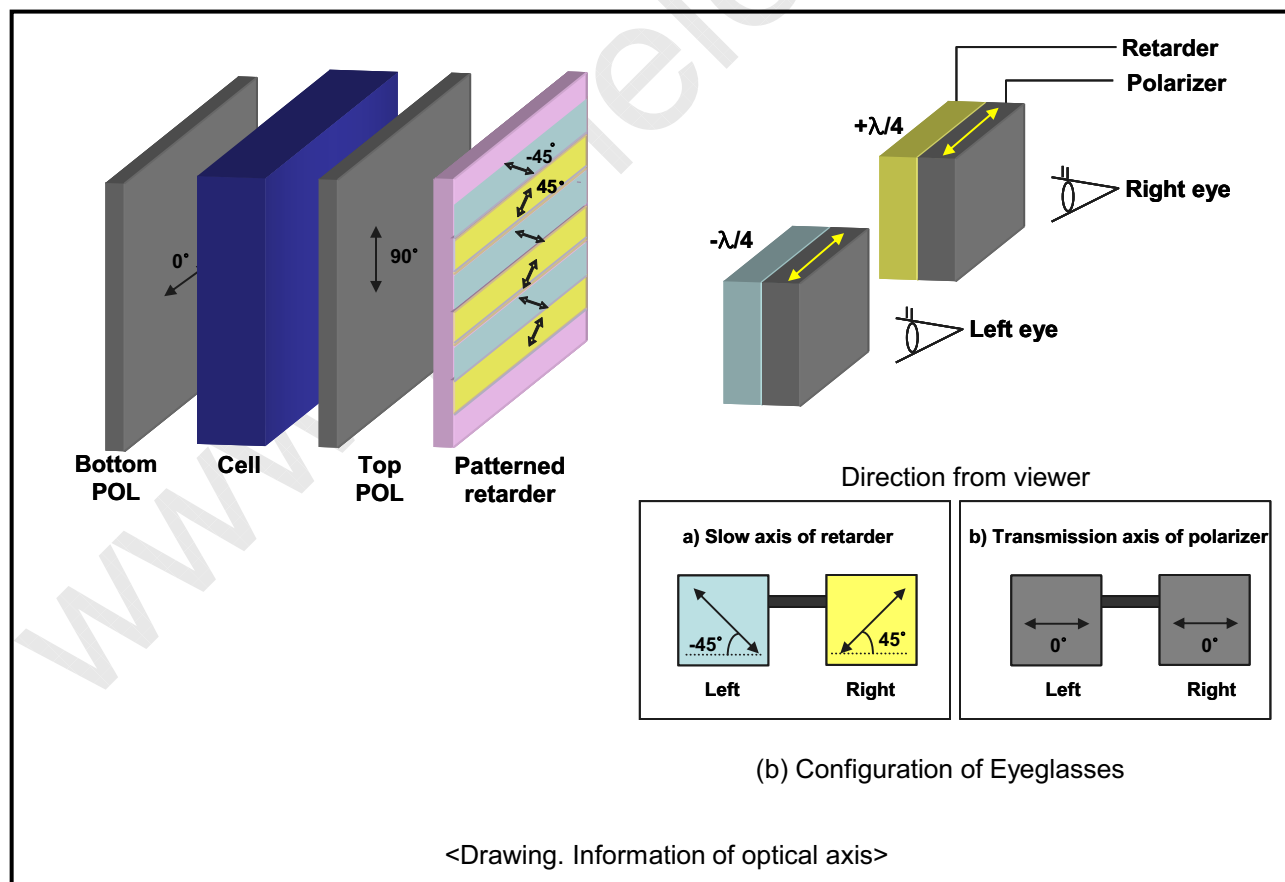

Ver. 0.1

Product Specification

APPENDIX- VIII

■ White Uniformity

This is only the reference white uniformity for LC370EUN-SEF1 model.

1. Measurement Condition

Surface luminance is determined after the unit has been 'ON' and 1 Hour after lighting the backlight in a dark environment at $25 \pm 2^\circ\text{C}$.

Where L1 to L9 are the luminance with all pixels displaying white at 9 locations .

2. Sampling Size : 5 pcs

3. Measurement Method : refer to below.

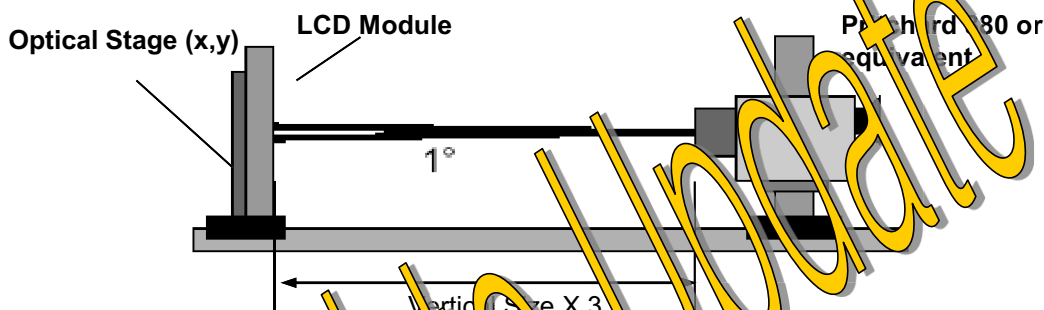

4. Measurement location: refer to below.

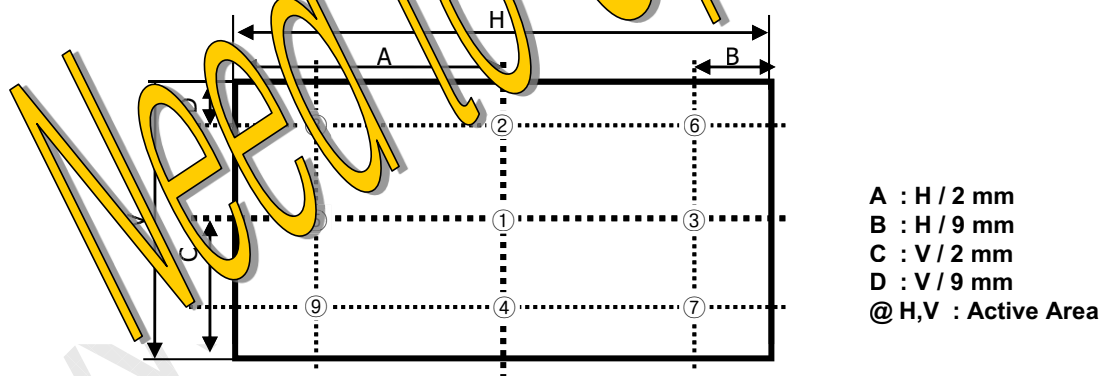

5. Current Status

Below table is actual data of production on **Aug. 28. 2011** (LGD RV Event Sample)

No.	L1	L2	L3	L4	L5	L6	L7	L8	L9
1									
2									
3									
4									
5									

RV Sample로 Update 예정