



LC370WX1  
Liquid Crystal Display

Product Specification

## SPECIFICATION FOR APPROVAL

- ( ● ) Preliminary Specification  
(   ) Final Specification

Title	37.0" WXGA TFT LCD
-------	--------------------

BUYER	General
MODEL	

SUPPLIER	LG.Philips LCD Co., Ltd.
*MODEL	LC370WX1
SUFFIX	SL03(Lead Free)

\*When you obtain standard approval,  
please use the above model name without suffix

APPROVED BY	SIGNATURE	DATE
/	_____	_____
/	_____	_____
/	_____	_____

Please return 1 copy for your confirmation with your signature and comments.

APPROVED BY	SIGNATURE	DATE
J.H Lee / G.Manager	_____	_____
<b>REVIEWED BY</b>		
J.Y. Lee / Manager	_____	_____
<b>PREPARED BY</b>		
J.Y. Ryu / Engineer	_____	_____

**TV Product Development Dept.**  
**LG. Philips LCD Co., Ltd**



LC370WX1  
Liquid Crystal Display

Product Specification

Contents

Number	ITEM	Page
	COVER	1
	CONTENTS	2
	RECORD OF REVISIONS	3
1	GENERAL DESCRIPTION	4
2	ABSOLUTE MAXIMUM RATINGS	5
3	ELECTRICAL SPECIFICATIONS	6
3-1	ELECTRICAL CHARACTERISTICS	6
3-2	INTERFACE CONNECTIONS	8
3-3	SIGNAL TIMING SPECIFICATIONS	12
3-4	SIGNAL TIMING WAVEFORMS	13
3-5	COLOR INPUT DATA REFERENCE	14
3-6	POWER SEQUENCE	15
4	OPTICAL SPECIFICATIONS	17
5	MECHANICAL CHARACTERISTICS	21
6	RELIABILITY	24
7	INTERNATIONAL STANDARDS	25
7-1	SAFETY	25
7-2	EMC	25
8	PACKING	26
8-1	DESIGNATION OF LOT MARK	26
8-2	PACKING FORM	26
9	PRECAUTIONS	27
9-1	MOUNTING PRECAUTIONS	27
9-2	OPERATING PRECAUTIONS	27
9-3	ELECTROSTATIC DISCHARGE CONTROL	28
9-4	PRECAUTIONS FOR STRONG LIGHT EXPOSURE	28
9-5	STORAGE	28
9-6	HANDLING PRECAUTIONS FOR PROTECTION FILM	28



## Product Specification

### 1. General Description

LC370WX1 is a Color Active Matrix Liquid Crystal Display with an integral External Electrode Fluorescent Lamp(EEFL) backlight system. The matrix employs a-Si Thin Film Transistor as the active element. It is a transmissive type display operating in the normally black mode. It has a 37.02 inch diagonally measured active display area with WXGA resolution (768 vertical by 1366 horizontal pixel array) Each pixel is divided into Red, Green and Blue sub-pixels or dots which are arranged in vertical stripes. Gray scale or the luminance of the sub-pixel color is determined with a 8-bit gray scale signal for each dot, thus presenting a palette of more than 16.7M(true) colors.

It has been designed to apply the 8-bit 1 port LVDS interface.

It is intended to support LCD TV, PCTV where high brightness, super wide viewing angle, high color gamut, high color depth and fast response time are important.

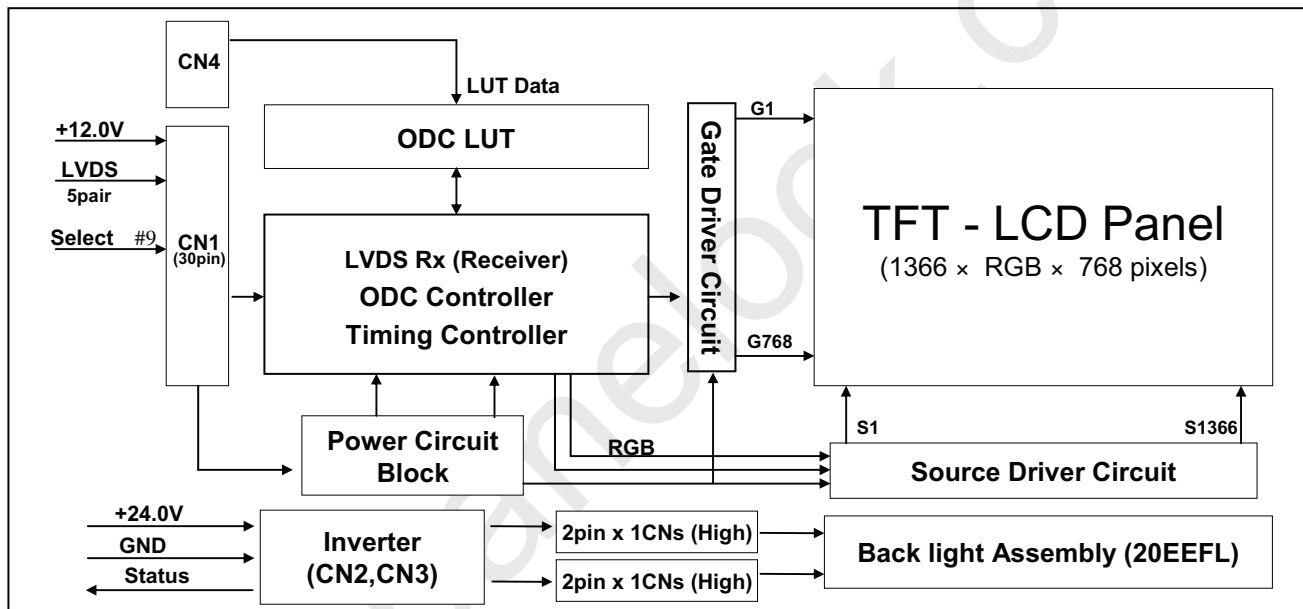

### General Features

Active Screen Size	37.02 inches(940.3mm) diagonal
Outline Dimension	877.0mm(H) x 516.8mm(V) x 55.5mm(D) (Typ.)
Pixel Pitch	0.200mm x 0.600mm x RGB
Pixel Format	1366 horiz. by 768 vert. pixels RGB stripe arrangement
Color Depth	8-bit, 16.7 M colors
Luminance, White	500 cd/m <sup>2</sup> (Center 1 point Typ.)
Viewing Angle (CR>10)	Viewing angle free ( R/L 178(Typ.), U/D 178(Typ.))
Power Consumption	Total 126Watt (Typ.) (Logic=4.7W, B/L=120W [I <sub>LAMP</sub> =100mA] )
Weight	10,500g (Typ.)
Display Operating Mode	Transmissive mode, normally black
Surface Treatment	Hard coating(3H), Anti-glare treatment of the front polarizer

## Product Specification

## 2. Absolute Maximum Ratings

The followings are maximum values which, if exceeded, may cause faulty operation or damage to the unit.

**Table 1. ABSOLUTE MAXIMUM RATINGS**

Parameter		Symbol	Value		Unit	Remark
			Min	Max		
Power Input Voltage	LCM	VLCD	-0.3	14.0	V <sub>DC</sub>	at 25 ± 2 °C
	Backlight inverter	VBL	21.6	27.0	V <sub>DC</sub>	When operating
ON/OFF Control Voltage		VON/OFF	-0.30	5.25	V <sub>DC</sub>	
Brightness Control Voltage		VBr	-	3.3	V <sub>DC</sub>	
Operating Temperature		TOP	0	40	°C	Note 1
Storage Temperature		TST	-20	50	°C	
Operating Ambient Humidity		HOP	10	90	%RH	
Storage Humidity		HST	10	90	%RH	

Note : 1. Temperature and relative humidity range are shown in the figure below.  
 Wet bulb temperature should be 39 °C Max. and no condensation of water.

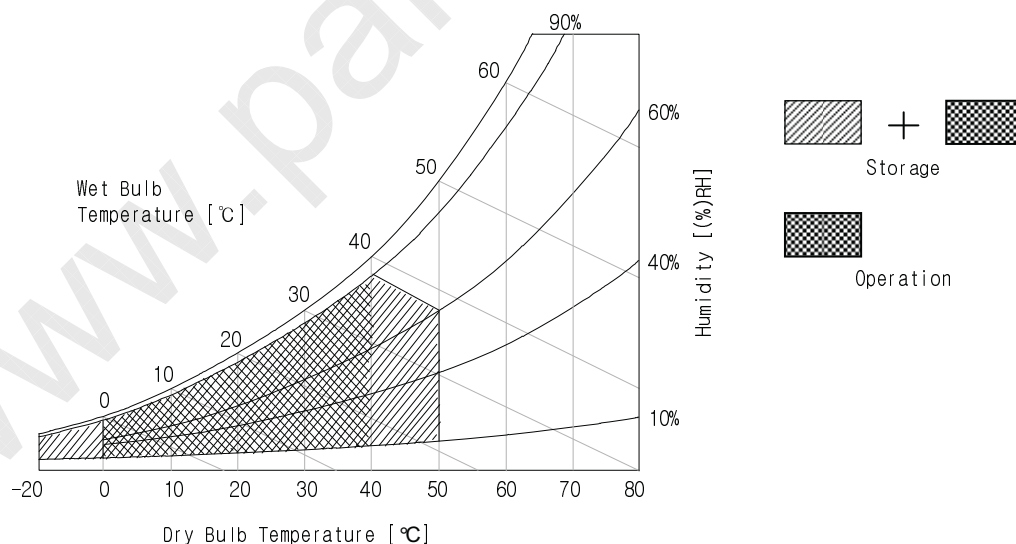

## Product Specification

### 3. Electrical Specifications

#### 3-1. Electrical Characteristics

It requires two power inputs. One is employed to power the LCD electronics and to drive the TFT array and liquid crystal. The other input power for the EEFL/Backlight is to power inverter.

**Table 2\_1. ELECTRICAL CHARACTERISTICS**

Parameter	Symbol	Value			Unit	Note
		Min	Typ	Max		
MODULE :						
Power Input Voltage	VLCD	11.4	12.0	12.6	V <sub>DC</sub>	
Permissible Input Ripple Voltage	VRP	-	-	200	mV <sub>P-P</sub>	
Power Input Current	ILCD	-	470	600	mA	1
		-	620	820	mA	2
Power Consumption	PLCD	-	5.6	7.2	Watt	1
Rush current	IRUSH	-	-	3.5	A	3

Note :

1. The specified current and power consumption are under the  $V_{LCD}=12.0V$ ,  $25 \pm 2^{\circ}C$ ,  $f_v=60Hz$  condition whereas mosaic pattern(8 x 6) is displayed and  $f_v$  is the frame frequency.
2. The current is specified at the maximum current pattern.
3. The duration of rush current is about 2ms and rising time of power Input is 1ms(min.).

White : 255Gray  
 Black : 0Gray

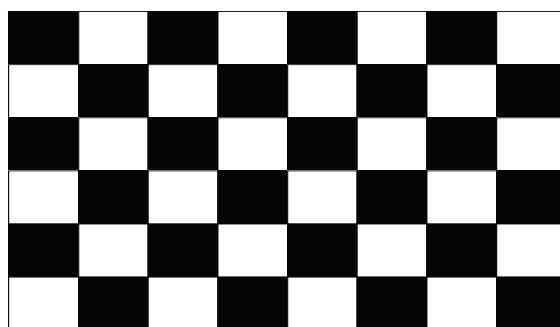

Mosaic Pattern(8 x 6)



LC370WX1  
Liquid Crystal Display

Product Specification

Table 2\_2. ELECTRICAL CHARACTERISTICS

Parameter	Symbol	Value			Unit	Note		
		Min	Typ	Max				
Inverter :								
Power Input Voltage	VBL	22.8	24.0	25.2	VDC	1		
Power Input Voltage Ripple		-	-	200	mVp-p			
Power Input Current	Operating	IBL	-	5.0	5.5	A	1	
	Turn on	IBL	-	5.5	6.0	A	1, 2	
Power Consumption	PBL	-	120	132	W	1		
Input Voltage for Control System Signals	Brightness Adjust		VBR	-	-	3.3	VDC	3
	On/Off	On	V on	3.00	5.00	-	VDC	
		Off	V off	-0.3	0.0	0.5	VDC	
Lamp :								
Life Time		50,000	60,000	-	Hrs	4		

Note :

- Electrical characteristics are determined after the unit has been 'ON' and stable for approximately 120Min at  $25 \pm 2^\circ\text{C}$  and  $V_{BR} = 3.3\text{V}$ .  
The specified current and power consumption are under the typical supply Input voltage, 24.0V.  
It is total power consumption.
- It is not inrush current, it is the current at turn on time.
- The life time is determined as the time at which luminance of the lamp is 50% compared to that of initial value at the typical lamp current on condition of continuous operating at  $25 \pm 2^\circ\text{C}$ .  
Specified value is when lamp is aligned horizontally.



LC370WX1  
Liquid Crystal Display

## Product Specification

### 3-2. Interface Connections

This LCD employs two kinds of interface connection, a 30-pin connector is used for the module electronics and two 12-pin Connectors are used for the integral backlight system.

#### 3-2-1. LCD Module

- LCD Connector(CN1) : FI-X30SSL-HF (Manufactured by JAE) or Equivalent
- Mating Connector : FI-X30C2L (Manufactured by JAE) or Equivalent

**Table 3. MODULE CONNECTOR(CN1) PIN CONFIGURATION**

Pin No.	Symbol	Description	Note
1	VLCD	Power Supply +12.0V	
2	VLCD	Power Supply +12.0V	
3	VLCD	Power Supply +12.0V	
4	VLCD	Power Supply +12.0V	
5	GND	Ground	
6	GND	Ground	
7	GND	Ground	
8	GND	Ground	
9	Select	Select LVDS Data format	1
10	NC	NC	
11	GND	Ground	
12	RA-	LVDS Receiver Signal(-)	
13	RA+	LVDS Receiver Signal(+)	
14	GND	Ground	
15	RB-	LVDS Receiver Signal(-)	
16	RB+	LVDS Receiver Signal(+)	
17	GND	Ground	
18	RC-	LVDS Receiver Signal(-)	
19	RC+	LVDS Receiver Signal(+)	
20	GND	Ground	
21	RCLK-	LVDS Receiver Clock Signal(-)	
22	RCLK+	LVDS Receiver Clock Signal(+)	
23	GND	Ground	
24	RD-	LVDS Receiver Signal(-)	
25	RD+	LVDS Receiver Signal(+)	
26	GND	Ground	
27	NC	NC	
28	NC	NC	
29	GND	Ground	
30	GND	Ground	2

- Note:
1. If the pin no. 9 is Ground, Interface format is "LG", and if the pin no. 9 is Vcc(3.3V), Interface format is "DISM". See page 9 and 10.
  2. The pin no. 30 is necessary for LCD test.  
When LVDS signals are abnormal operation more than 3-Vsync times and power 12V is supplied,  
'Open' or 'Vcc' : LCD operate itself some test patterns.(AGP – Auto Generation Pattern)  
'Ground' : LCD operate itself a black pattern. (NSB – No Signal Black)  
LPL recommend 'Ground' for NSB.
  3. All GND (ground) pins should be connected together, which should be also connected to the LCD module's metal frame.
  4. All VLCD (power input) pins should be connected together.
  5. Input Levels of LVDS signals are based on the IEA 664 Standard.



## Product Specification

Table 4. REQUIRED SIGNAL ASSIGNMENT FOR LVDS TRANSMITTER ( Pin9="L" or "Open" )

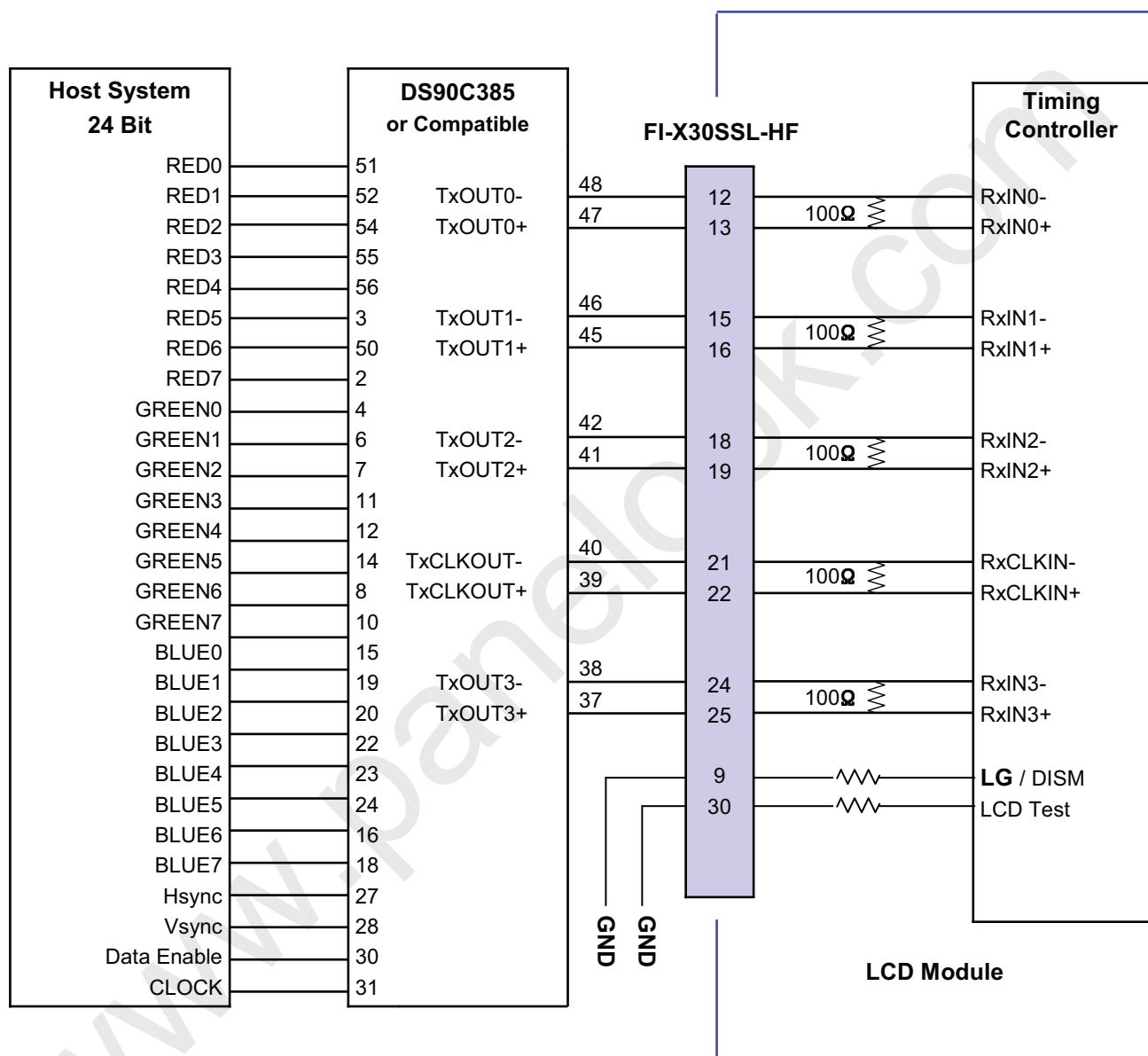

- Note: 1. The LCD Module uses a 100 Ohm[Ω] resistor between positive and negative lines of each receiver input.
2. Refer to LVDS Transmitter Data Sheet for detail descriptions. (DS90C385 or Compatible)
3. '7' means MSB and '0' means LSB at R,G,B pixel data.

## Product Specification

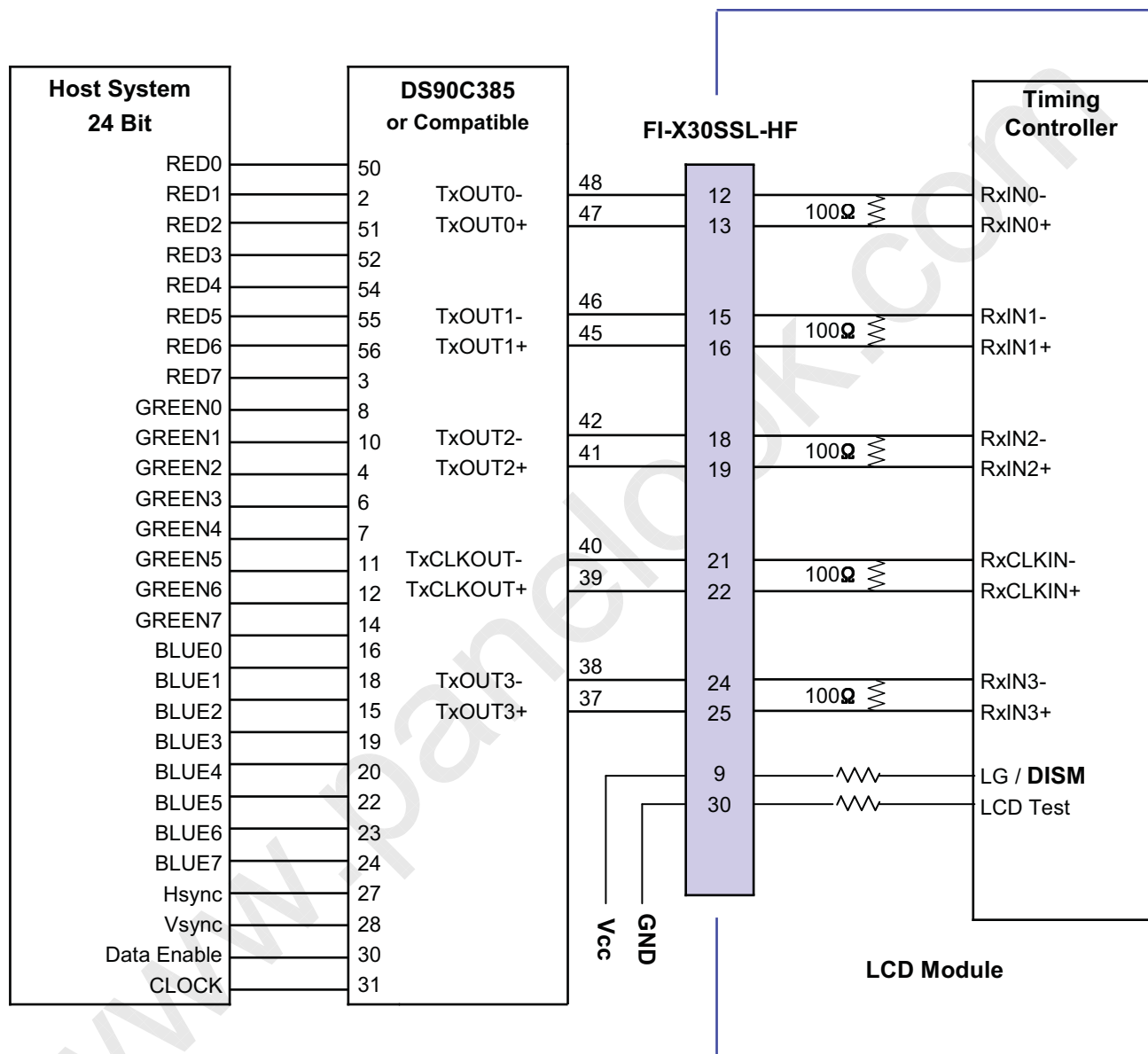
**Table 5. REQUIRED SIGNAL ASSIGNMENT FOR LVDS TRANSMITTER ( Pin9="H" )**

- Note: 1. The LCD Module uses a 100 Ohm[Ω] resistor between positive and negative lines of each receiver input.  
 2. Refer to LVDS Transmitter Data Sheet for detail descriptions. (DS90C385 or Compatible)  
 3. '7' means MSB and '0' means LSB at R,G,B pixel data.

## Product Specification

**3-2-2. Backlight Inverter**

Input Connector

- Inverter Connector : S12B-PH-SM3(manufactured by JST) or Equivalent
- Mating Connector : PHR-12 or Equivalent

Status Connector

- Inverter Connector : 20022WR-02A00(manufactured by Yeon Ho co., Korea) or Equivalent
- Mating Connector : 20022HR-02S00(manufactured by Yeon Ho co., Korea) or Equivalent

**Table 6. INVERTER CONNECTOR PIN CONFIGURATION**

Pin No	Symbol	Description	Master	Slave	Note
1	VBL	Power Supply +24.0V	VBL	VBL	
2	VBL	Power Supply +24.0V	VBL	VBL	
3	VBL	Power Supply +24.0V	VBL	VBL	
4	VBL	Power Supply +24.0V	VBL	VBL	
5	VBL	Power Supply +24.0V	VBL	VBL	
6	GND	POWER GND	GND	GND	
7	GND	POWER GND	GND	GND	
8	GND	POWER GND	GND	GND	1
9	GND	POWER GND	GND	GND	
10	GND	POWER GND	GND	GND	
11	VBR	3.3V	VBR	Don't care	2
12	On/Off	0V ~ 5.0V	On/Off	Don't care	3
Option Pin(Lamp Open Status Detection)					
1	GND	POWER GND	GND		
2	Status	Upper 3.0V(Normal), Under 0.5V(Abnormal)	Status		

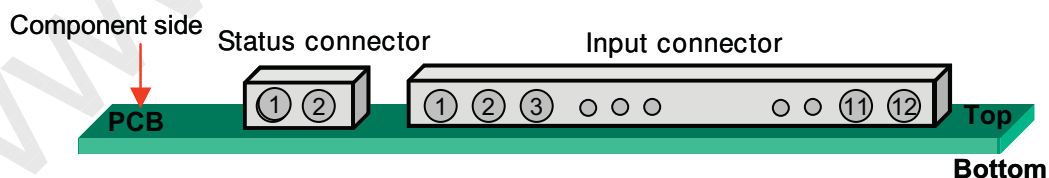

Note : 1. GND should be connected to the LCD module's metal frame.

2. Maximum Brightness : VBR = 3.3V

 3. VON : 3.0 ~ 5.0V  
 VOFF : -0.3 ~ 0.5V



LC370WX1  
Liquid Crystal Display

## Product Specification

### 3-3. Signal Timing Specifications

This is the signal timing required at the input of LVDS Transmitter. All of the interface signal timing should be satisfied with the following specifications for its proper operation.

Table 7. TIMMING TABLE

Item	Symbol		Min	Typ	Max	Unit	Remark
DCLK	Period	tCLK	12.2	13.8	14.7	ns	
	Frequency	-	68	72	80	MHz	
Hsync	Period	tHP	1472	1528	1776	tCLK	Note 2
	Frequency	fH	45	47.4	50	KHz	
	Width	tWH	16	32	160	tCLK	
Vsync	Period	tVP	776	790	1063	tHP	Note 1 PAL : 47~53Hz NTSC : 57~63Hz Note 2
	Frequency	fV	47	60	63	Hz	
	Width	tWV	2	5	50	tHP	
DE (Data Enable)	Horizontal Valid	tHV	1366	1366	1366	tCLK	
	Horizontal Back Porch	tHBP	48	80	280		
	Horizontal Front Porch	tHFP	40	48	240		
	Horizontal Blank	-	104	160	tHP- tHV		
	Vertical Valid	tVV	768	768	768	tHP	
	Vertical Back Porch	tVBP	5	15	150		
	Vertical Front Porch	tVFP	1	2	120		
	Vertical Blank	-	8	22	tVP- tVV		

**Note:** Hsync period and Hsync Width should be even number times of tCLK. If the value is odd number times of tCLK, display control signal can be asynchronous. In order to operate this LCD module, Hsync, Vsync, and DE(Data Enable) signals should be used.

1. : The performance of the electro-optical characteristics may be influenced by variance of the vertical refresh rate.
2. Vsync and Hsync should be keep the above specification and negative polarity.
3. Hsync Period, Hsync Width and Horizontal Back Porch should be any times of character number(8).

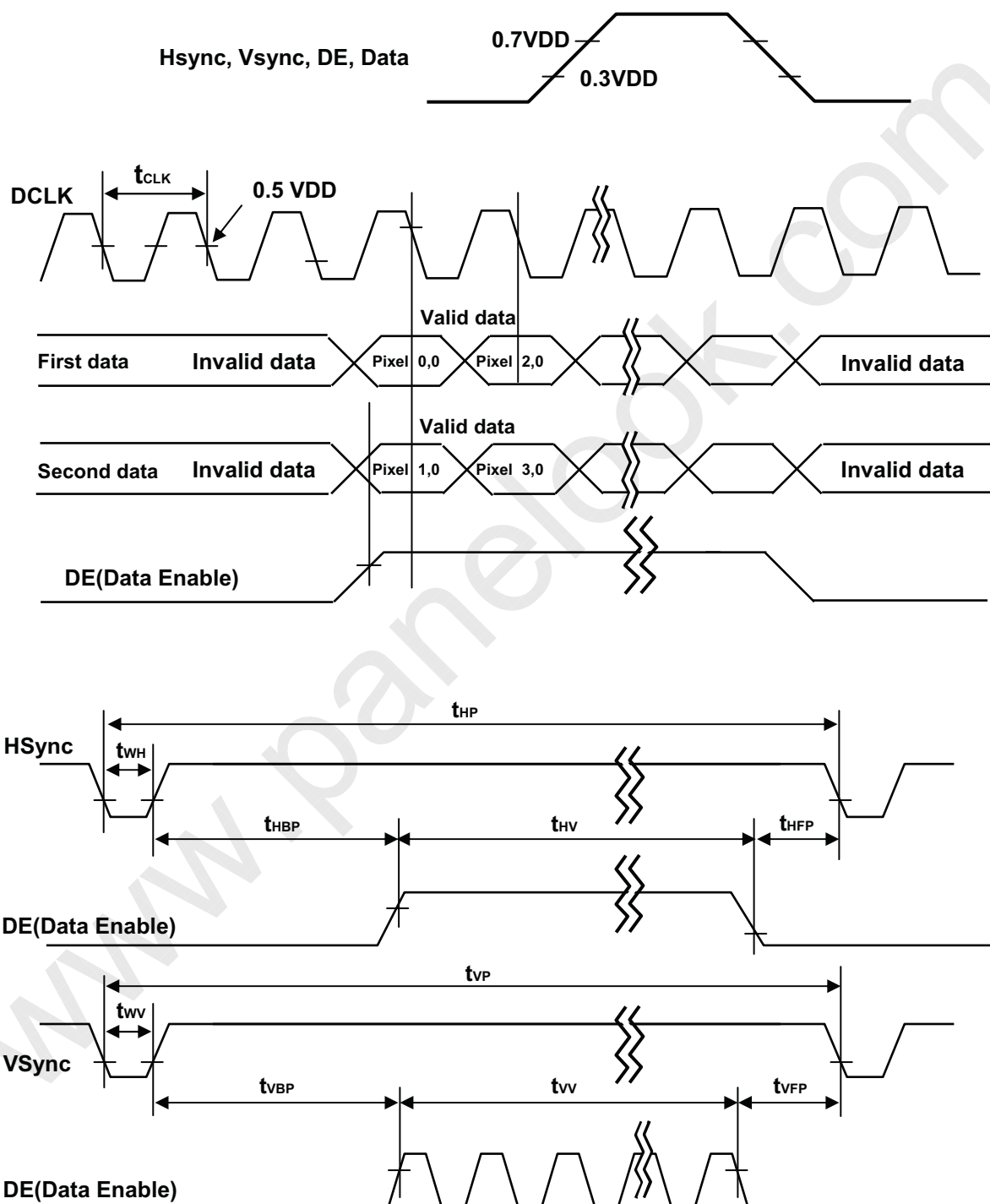
**3-4. Signal Timing Waveforms**



LC370WX1  
Liquid Crystal Display

Product Specification

### 3-5. Color Data Reference

The brightness of each primary color(red,green,blue) is based on the 8-bit gray scale data input for the color the higher the binary input, the brighter the color. The table below provides a reference for color versus data input.

Table 8. COLOR DATA REFERENCE

Color		Input Color Data																							
		RED								GREEN								BLUE							
		MSB							LSB	MSB							LSB	MSB							LSB
		R7	R6	R5	R4	R3	R2	R1	R0	G7	G6	G5	G4	G3	G2	G1	G0	B7	B6	B5	B4	B3	B2	B1	B0
Basic Color	Black	0	0	0	0	0	0	0	0	0	0	0	0	0	0	0	0	0	0	0	0	0	0	0	0
	Red (255)	1	1	1	1	1	1	1	1	0	0	0	0	0	0	0	0	0	0	0	0	0	0	0	0
	Green (255)	0	0	0	0	0	0	0	0	1	1	1	1	1	1	1	1	0	0	0	0	0	0	0	0
	Blue (255)	0	0	0	0	0	0	0	0	0	0	0	0	0	0	0	0	1	1	1	1	1	1	1	1
	Cyan	0	0	0	0	0	0	0	0	1	1	1	1	1	1	1	1	1	1	1	1	1	1	1	1
	Magenta	1	1	1	1	1	1	1	1	0	0	0	0	0	0	0	0	1	1	1	1	1	1	1	1
	Yellow	1	1	1	1	1	1	1	1	1	1	1	1	1	1	1	1	0	0	0	0	0	0	0	0
	White	1	1	1	1	1	1	1	1	1	1	1	1	1	1	1	1	1	1	1	1	1	1	1	1
RED	RED (000) Dark	0	0	0	0	0	0	0	0	0	0	0	0	0	0	0	0	0	0	0	0	0	0	0	0
	RED (001)	0	0	0	0	0	0	0	1	0	0	0	0	0	0	0	0	0	0	0	0	0	0	0	0
	...	...								...								...							
	RED (254)	1	1	1	1	1	1	1	0	0	0	0	0	0	0	0	0	0	0	0	0	0	0	0	0
	RED (255)	1	1	1	1	1	1	1	1	0	0	0	0	0	0	0	0	0	0	0	0	0	0	0	0
GREEN	GREEN (000) Dark	0	0	0	0	0	0	0	0	0	0	0	0	0	0	0	0	0	0	0	0	0	0	0	0
	GREEN (001)	0	0	0	0	0	0	0	0	0	0	0	0	0	0	0	1	0	0	0	0	0	0	0	0
	...	...								...								...							
	GREEN (254)	0	0	0	0	0	0	0	0	1	1	1	1	1	1	1	0	0	0	0	0	0	0	0	0
	GREEN (255)	0	0	0	0	0	0	0	0	1	1	1	1	1	1	1	1	0	0	0	0	0	0	0	0
BLUE	BLUE (000) Dark	0	0	0	0	0	0	0	0	0	0	0	0	0	0	0	0	0	0	0	0	0	0	0	0
	BLUE (001)	0	0	0	0	0	0	0	0	0	0	0	0	0	0	0	0	0	0	0	0	0	0	0	1
	...	...								...								...							
	BLUE (254)	0	0	0	0	0	0	0	0	0	0	0	0	0	0	0	0	1	1	1	1	1	1	1	0
	BLUE (255)	0	0	0	0	0	0	0	0	0	0	0	0	0	0	0	0	1	1	1	1	1	1	1	1

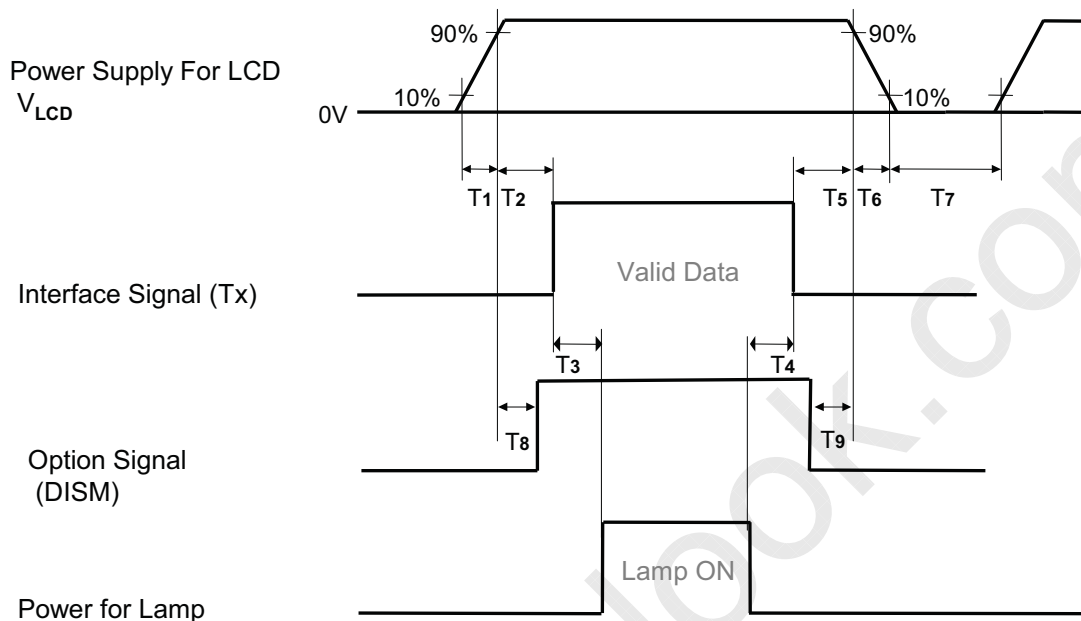
**Product Specification**
**3-6. Power Sequence**

**Table 9. POWER SEQUENCE**

Parameter	Value			Unit
	Min	Typ	Max	
T1	1.0	-	20	ms
T2	5.0	-	50	ms
T3	200	-	-	ms
T4	200	-	-	ms
T5	0.5	-	50	ms
T6	-	-	300	ms
T7	2.0	-	-	s
T8	0 < T8 < T2			ms
T9	0 < T9 < T5			ms

- Note :
1. Please avoid floating state of interface signal at invalid period.
  2. When the interface signal is invalid, be sure to pull down the power supply  $V_{LCD}$  to 0V.
  3. The case when the T2/T5 exceed maximum specification, it operates protection pattern(Black pattern) till valid signal inputted. There is no reliability problem.
  4. The T3/T4 is recommended value, the case when failed to meet a minimum specification, abnormal display would be shown. There is no reliability problem.
  5. If the on time of option signal(DISM) precedes the on time of Power( $V_{LCD}$ ), check the LCD logic Power( $V_{cc}$ ) is under 0.8V, otherwise it will be happened abnormal display.

## Product Specification

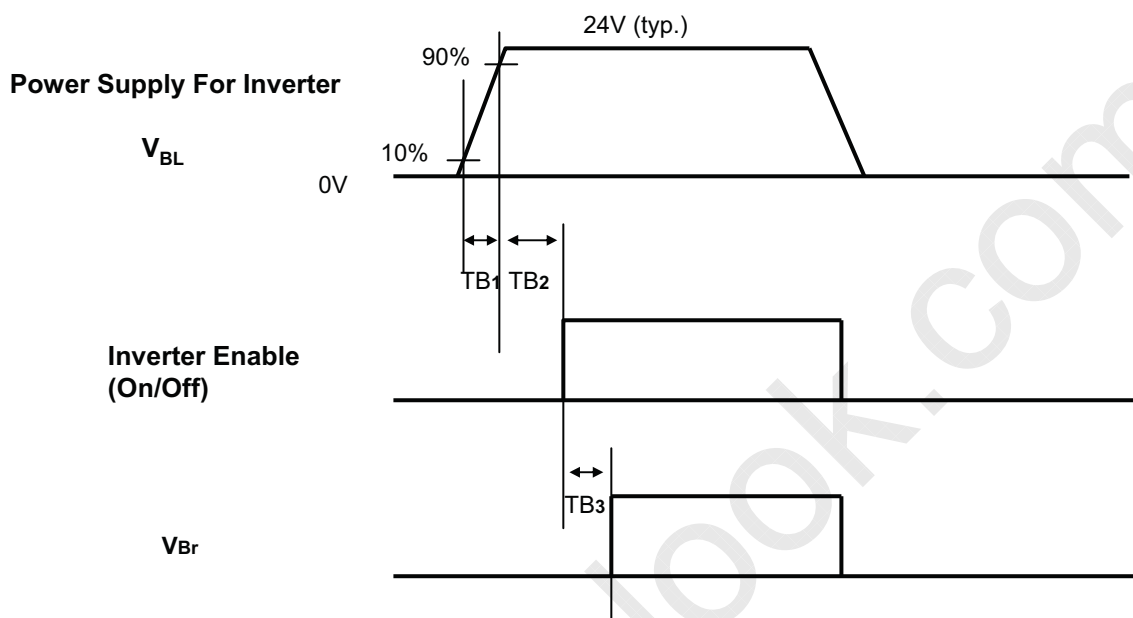
## 3-6-2. Power Sequence for Inverter



## 3-6-3. Deep condition for Inverter

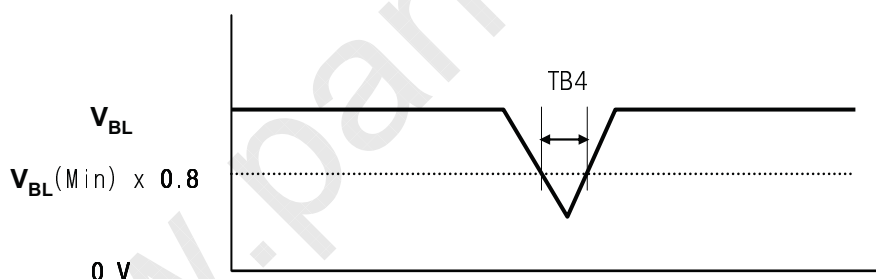

Table 10. POWER SEQUENCE FOR INVERTER

Parameter	Value			Unit	Remark
	Min	Typ	Max		
TB1	20	-	-	ms	After Inverter's connected
TB2	500	-	-	ms	
TB3	0	-	-	ms	
TB4	-	-	10	ms	$V_{BL(Min)} \times 0.8$

Note : TB1 describes rising time of 0V to 24V and is not applied at restarting time.  
 When the 24V Power is restart, the inverter enable signal must be restarted.



## Product Specification

#### 4. Optical Specification

Optical characteristics are determined after the unit has been 'ON' for 30min in a dark environment at  $25 \pm 2^\circ\text{C}$ . The values specified are at an approximate distance 50cm from the LCD surface at a viewing angle of  $\Phi$  and  $\theta$  equal to  $0^\circ$ .

It is presented additional information concerning the measurement equipment and method in FIG. 1.

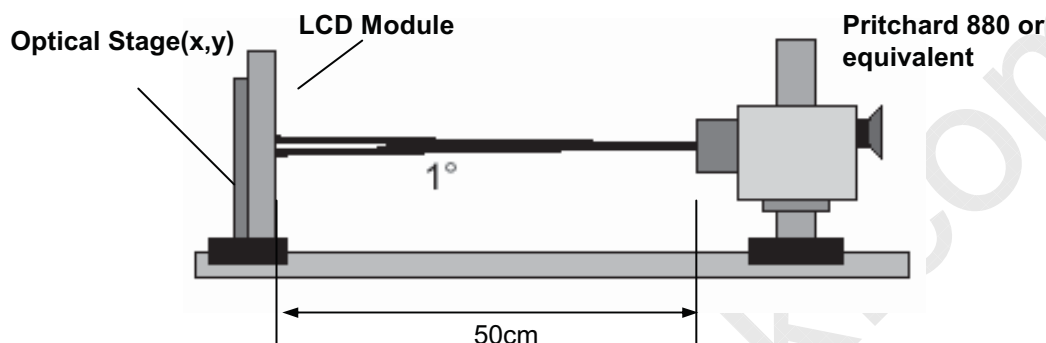

FIG. 1 Optical Characteristic Measurement Equipment and Method

Table 11. OPTICAL CHARACTERISTICS

$T_a = 25 \pm 2^\circ\text{C}$ ,  $V_{LCD} = 12.0\text{V}$ ,  $f_v = 60\text{Hz}$ ,  $D_{clk} = 72\text{MHz}$ ,  $V_{BR} = 3.3\text{V}$

Parameter	Symbol	Value			Unit	Note	
		Min	Typ	Max			
Contrast Ratio	CR	600	800			1	
Surface Luminance, white	$L_{WH}$	400	500		$\text{cd/m}^2$	2	
Luminance Variation	$\delta_{WHITE}$ 5P			1.3		3	
Response Time	Rise Time	$Tr_R$	8	12	ms	4	
	Decay Time	$Tr_D$	10	14			
	G to G		8	14			
Color Coordinates [CIE1931]	RED	Rx	0.631	Typ +0.03			
		Ry	0.343				
	GREEN	Gx	0.280				
		Gy	0.600				
	BLUE	Bx	0.145				
		By	0.060				
	WHITE	Wx	0.272				
Wy	0.278						
Viewing Angle (CR>10)							
	x axis, right( $\phi=0^\circ$ )	$\theta_r$	85	89	-	degree	5
	x axis, left ( $\phi=180^\circ$ )	$\theta_l$	85	89	-		
	y axis, up ( $\phi=90^\circ$ )	$\theta_u$	85	89	-		
	y axis, down ( $\phi=270^\circ$ )	$\theta_d$	85	89	-		
Viewing Angle (CR>10) → Diagonal Direction Viewing Angle *** EZ Contrast 160R							
	x axis, right( $\phi=45^\circ$ )	$\theta_r$	85	89	-	degree	5
	x axis, left ( $\phi=135^\circ$ )	$\theta_l$	85	89	-		
	y axis, up ( $\phi=225^\circ$ )	$\theta_u$	85	89	-		
	y axis, down ( $\phi=315^\circ$ )	$\theta_d$	85	89	-		
Gray Scale							6



LC370WX1  
Liquid Crystal Display

### Product Specification

Notes 1. Contrast Ratio(CR) is defined mathematically as :

$$\text{Contrast Ratio} = \frac{\text{Surface Luminance with all white pixels}}{\text{Surface Luminance with all black pixels}}$$

It is measured at the center point(1).

- Surface luminance is luminance value at the center point across the LCD surface 50cm from the surface with all pixels displaying white.  
For more information, see FIG 2.
- The variation in surface luminance,  $\delta$  WHITE is defined as :  

$$\delta \text{ WHITE}(5P) = \frac{\text{Maximum}(L_{on1}, L_{on2}, L_{on3}, \dots, L_{on5})}{\text{Minimum}(L_{on1}, L_{on2}, L_{on3}, \dots, L_{on5})}$$
 Where  $L_{on1}$  to  $L_{on5}$  are the luminance with all pixels displaying white at 5 locations .  
For more information, see FIG 2.
- Response time is the time required for the display to transition from G(N) to G(M) (Rise Time,  $Tr_R$ ) and from G(M) to G(N) (Decay Time,  $Tr_D$ ). For additional information see the FIG. 3. ( $N < M$ )
- Viewing angle is the angle at which the contrast ratio is greater than 10. The angles are determined for the horizontal or x axis and the vertical or y axis with respect to the z axis which is normal to the LCD surface. For more information, see FIG 4.
- Gray scale specification  
Gamma Value is approximately 2.2.  
For more information, see Table 12.

**Table 12. GRAY SCALE SPECIFICATION**

Gray Level	Luminance [%] (Typ)
L0	0.12
L15	0.32
L31	1.10
L47	2.60
L63	4.90
L79	8.10
L95	12.1
L111	16.7
L127	21.6
L143	28.0
L159	35.4
L175	43.9
L191	53.3
L207	64.1
L223	75.8
L239	88.0
L255	100

## Product Specification

Measuring point for surface luminance &amp; measuring point for luminance variation

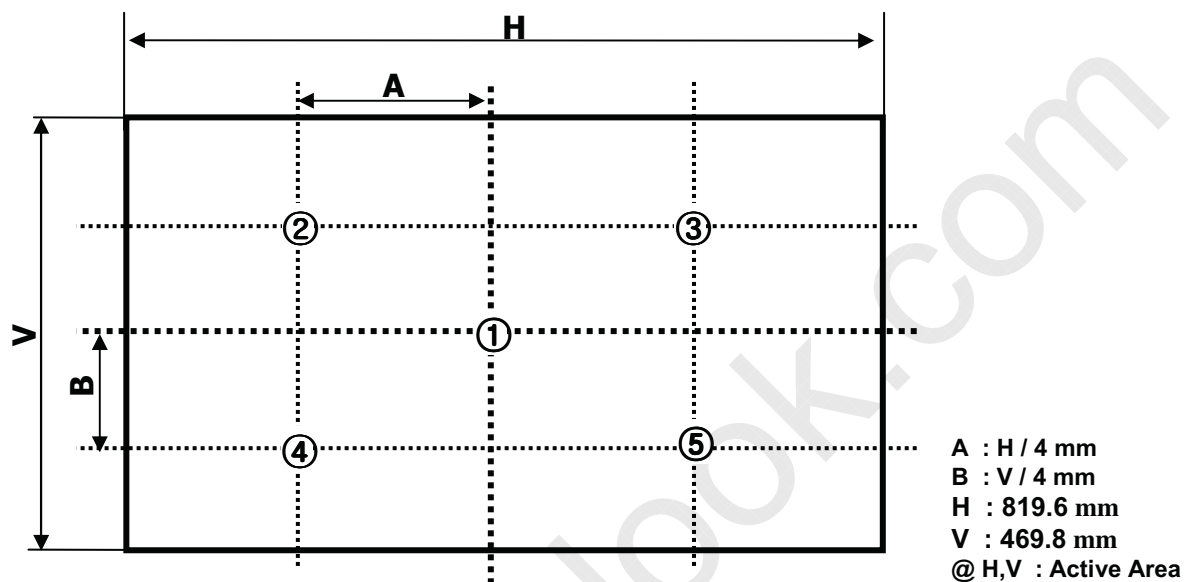

FIG. 2 Measure Point for Luminance

Response time is defined as the following figure and shall be measured by switching the input signal for "Gray(N)" and "Gray(M)".

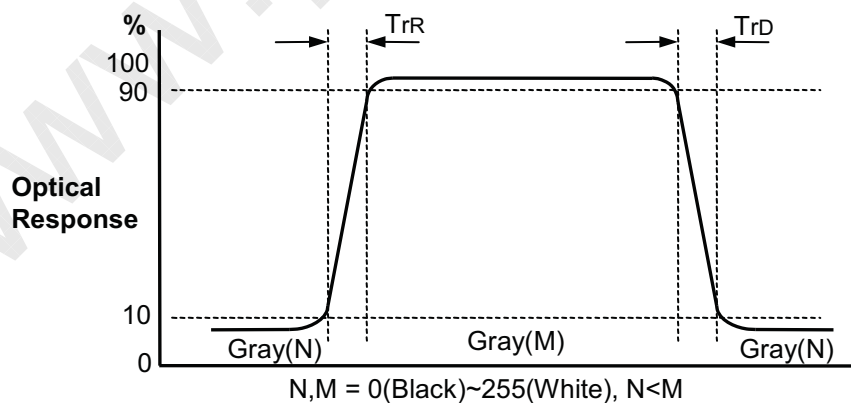

FIG. 3 Response Time

## Product Specification

## Dimension of viewing angle range

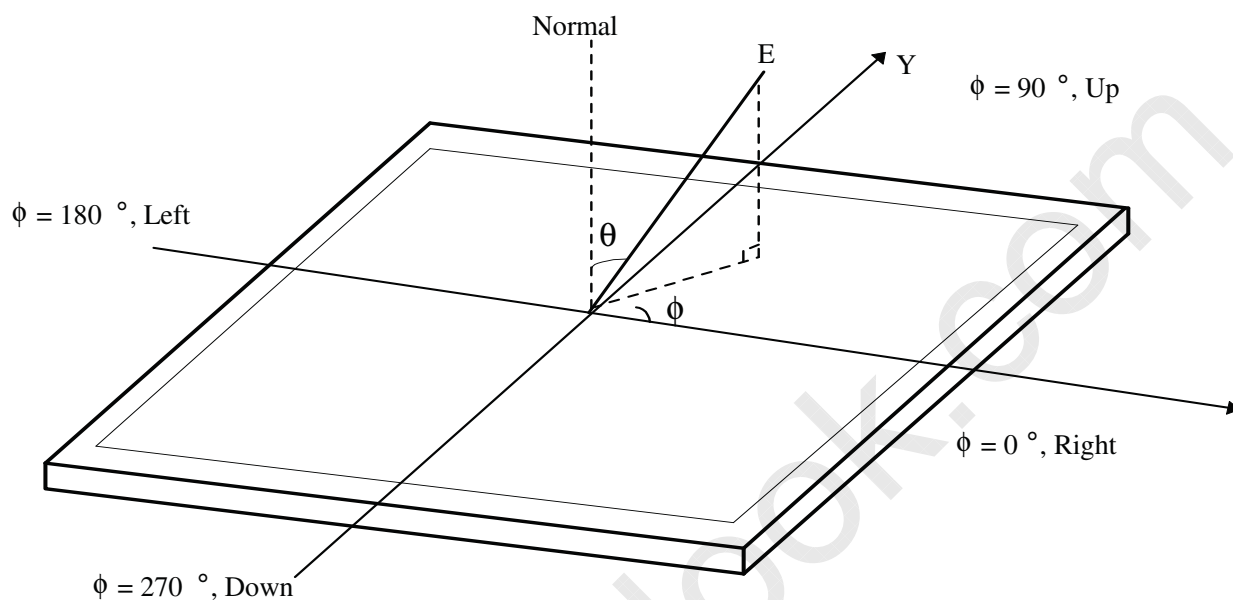

FIG. 4 Viewing angle

Optical characteristics are determined after the unit has been 'ON' for 30min in a dark environment at  $25 \pm 2^\circ\text{C}$ . The values specified are at an approximate distance 1.2mm from the LCD surface at a viewing angle of  $\Phi$  and  $\theta$  equal to  $0^\circ$ .

It is presented additional information concerning the measurement equipment and method in FIG. 1.

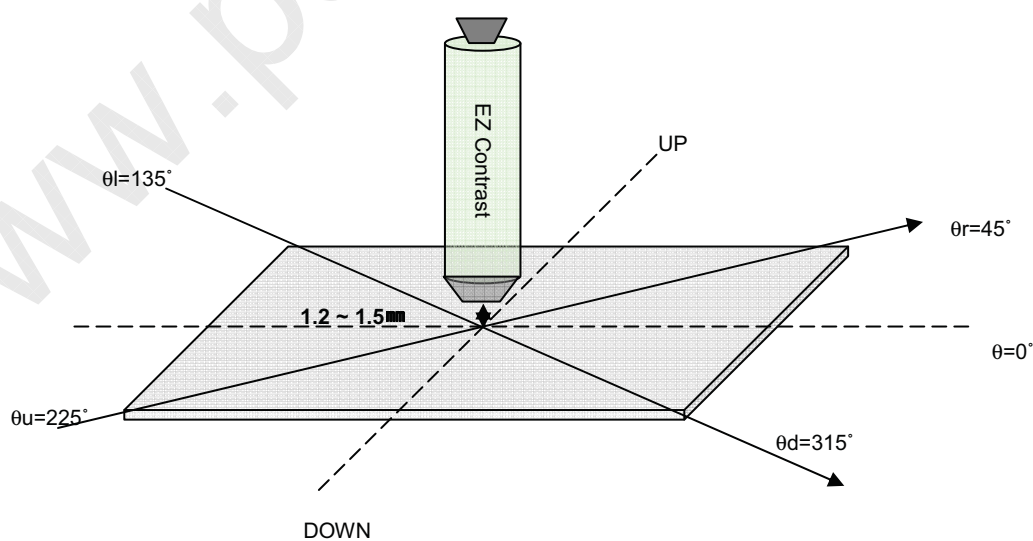

FIG. 5 Diagonal Viewing Angle Measurement Condition



LC370WX1  
Liquid Crystal Display

Product Specification

## 5. Mechanical Characteristics

The following items provide general mechanical characteristics. In addition the figures in the next page are detailed mechanical drawing of the LCD module.

**Table 13. MECHANICAL CHARACTERISTICS**

Outline Dimension	Horizontal	877.0 mm
	Vertical	516.8 mm
	Depth	55.5 mm
Bezel Area	Horizontal	828.6mm
	Vertical	469.8mm
Active Display Area	Horizontal	819.6mm
	Vertical	460.8mm
Weight	10,500 (Typ.)/11,000(Max)	
Surface Treatment	Hard coating(3H) Anti-glare treatment of the front polarizer	

Note : Please refer to a mechanic drawing in terms of tolerance at the next page.



LC370WX1  
Liquid Crystal Display

Product Specification

<FRONT VIEW>

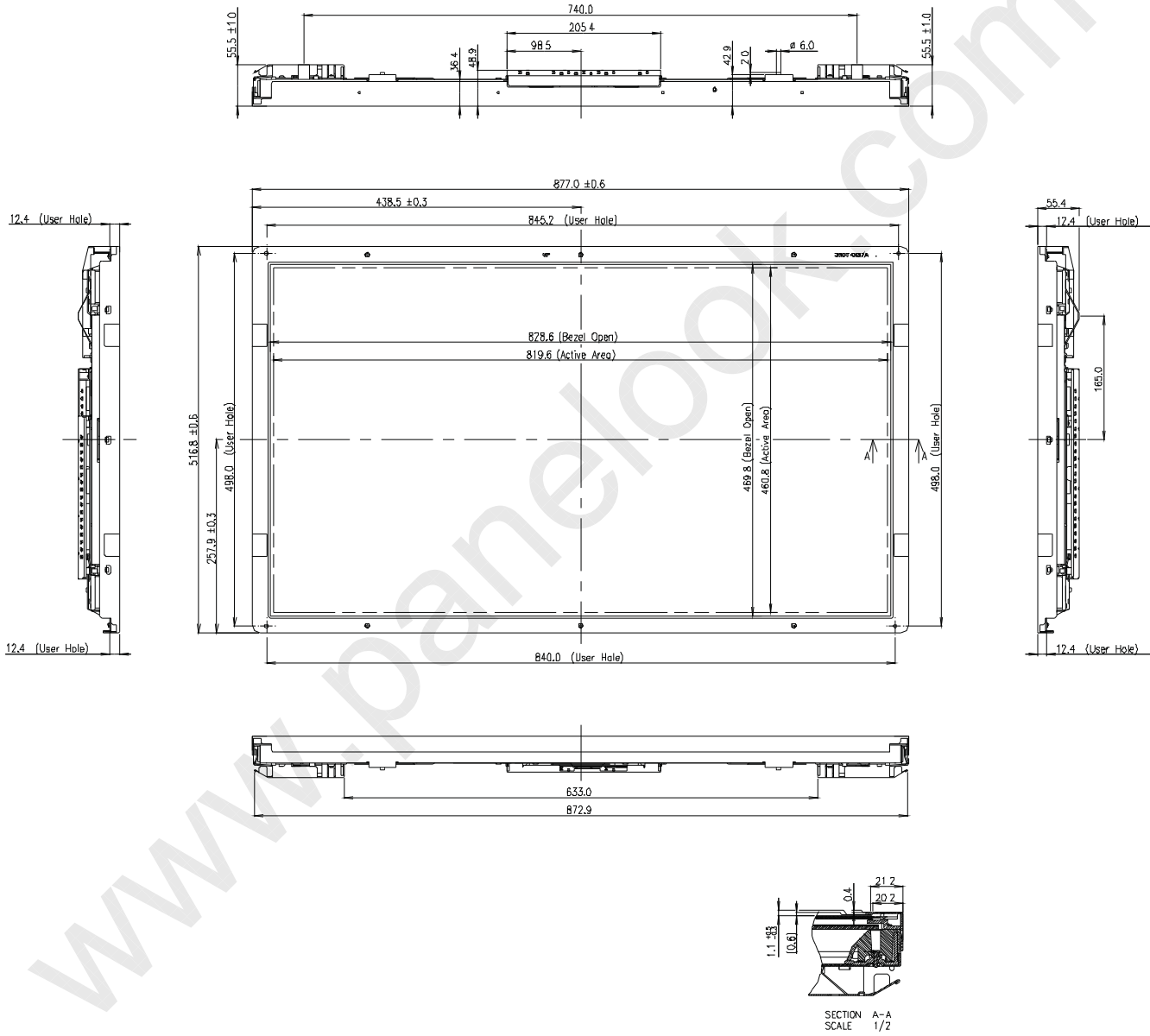

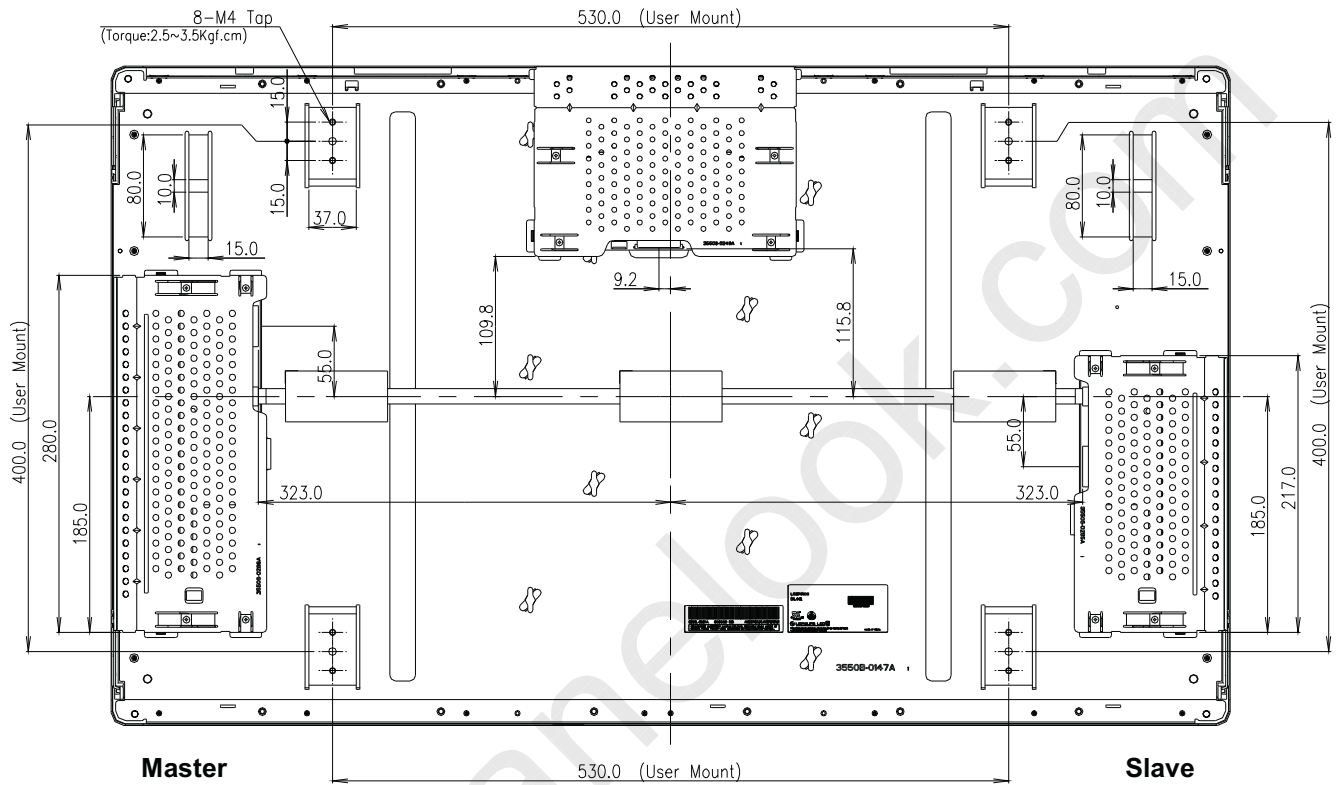
**Product Specification**
**<REAR VIEW>**

**NOTES**

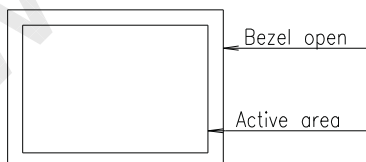
1. Unspecified tolerances are to be  $\pm 0.5\text{mm}$ .
2. This drawing is only preliminary data and can be changed without previous notice.
3. Tilt and partial disposition tolerance of display area are as following.
  - (1) X-Direction : IA-BI  $\leq 1.5\text{mm}$
  - (2) Y-Direction : IC-DI  $\leq 1.5\text{mm}$





LC370WX1  
Liquid Crystal Display

Product Specification

## 6. Reliability

Table 14. ENVIRONMENT TEST CONDITION

No.	Test Item	Condition
1	High temperature storage test	Ta= 50°C 240h
2	Low temperature storage test	Ta= -20°C 240h
3	High temperature operation test	Ta= 40°C 50%RH 240h
4	Low temperature operation test	Ta= 0°C 240h
5	Vibration test (non-operating)	Wave form : random Vibration level : 1.0G RMS Bandwidth : 10-500Hz Duration : X,Y,Z, 10 min One time each direction
6	Shock test (non-operating)	Shock level : 100G Waveform : half sine wave, 2ms Direction : ±X, ±Y, ±Z One time each direction
7	Humidity condition Operation	Ta= 40 °C, 90%RH, 240h
8	Altitude operating storage / shipment	0 - 14,000 feet(4267.2m) 0 - 40,000 feet(12192m)



LC370WX1  
Liquid Crystal Display

## Product Specification

## 7. International standards

### 7-1. Safety

- a) UL 60950-1:2003, First Edition, Underwriters Laboratories, Inc., Standard for Safety of Information Technology Equipment.
- b) CAN/CSA C22.2, No. 60950-1-03 1<sup>st</sup> Ed. April 1, 2003, Canadian Standards Association, Standard for Safety of Information Technology Equipment.
- c) EN 60950-1:2001, First Edition, European Committee for Electrotechnical Standardization(CENELEC) European Standard for Safety of Information Technology Equipment.

### 7-2. EMC

- a) ANSI C63.4 "Methods of Measurement of Radio-Noise Emissions from Low-Voltage Electrical and Electrical Equipment in the Range of 9kHz to 40GHz." American National Standards Institute(ANSI), 1992
- b) C.I.S.P.R. "Limits and Methods of Measurement of Radio Interface Characteristics of Information Technology Equipment." International Special Committee on Radio Interference.
- c) EN 55022 "Limits and Methods of Measurement of Radio Interface Characteristics of Information Technology Equipment." European Committee for Electrotechnical Standardization.(CENELEC), 1998 ( Including A1: 2000 )



LC370WX1  
Liquid Crystal Display

## Product Specification

### 8. Packing

#### 8-1. Designation of Lot Mark

##### a) Lot Mark

A	B	C	D	E	F	G	H	I	J	K	L	M
---	---	---	---	---	---	---	---	---	---	---	---	---

A,B,C : SIZE(INCH)

D : YEAR

F : PANEL CODE

H : ASSEMBLY CODE

E : MONTH

G : FACTORY CODE

I,J,K,L,M : SERIAL NO.

##### Note

##### 1. YEAR

Year	97	98	99	2000	2001	2002	2003	2004	2005	2006	2007
Mark	7	8	9	0	1	2	3	4	5	6	7

##### 2. MONTH

Month	Jan	Feb	Mar	Apr	May	Jun	Jul	Aug	Sep	Oct	Nov	Dec
Mark	1	2	4	4	5	6	7	8	9	A	B	C

##### 3. PANEL CODE

Panel Code	P1 Factory	P2 Factory	P3 Factory	P4 Factory	P5 Factory	Hydis Panel
Mark	1	2	3	4	5	H

##### 4. FACTORY CODE

Factory Code	LPL Gumi	LPL Nanjing	Hee Sung
Mark	K	C	D

##### 5. SERIAL NO.

Year	1 ~ 99999	100000 ~
Mark	00001 ~ 99999	A0001 ~ A9999, ..... , Z9999

##### b) Location of Lot Mark

Serial NO. is printed on the label. The label is attached to the backside of the LCD module.

This is subject to change without prior notice.

#### 8-2. Packing Form

a) Package quantity in one box : 5 pcs

b) Box Size : 973mm X 493mm X 577mm

LC370WX1  
Liquid Crystal Display

## Product Specification

## 9. Precautions

Please pay attention to the followings when you use this TFT LCD module.

### 9-1. Mounting Precautions

- (1) You must mount a module using holes arranged in four corners or four sides.
- (2) You should consider the mounting structure so that uneven force (ex. Twisted stress) is not applied to the module. And the case on which a module is mounted should have sufficient strength so that external force is not transmitted directly to the module.
- (3) Please attach the surface transparent protective plate to the surface in order to protect the polarizer. Transparent protective plate should have sufficient strength in order to resist external force.
- (4) You should adopt radiation structure to satisfy the temperature specification.
- (5) Acetic acid type and chlorine type materials for the cover case are not desirable because the former generates corrosive gas of attacking the polarizer at high temperature and the latter causes circuit break by electro-chemical reaction.
- (6) Do not touch, push or rub the exposed polarizers with glass, tweezers or anything harder than HB pencil lead. And please do not rub with dust clothes with chemical treatment. Do not touch the surface of polarizer for bare hand or greasy cloth.(Some cosmetics are detrimental to the polarizer.)
- (7) When the surface becomes dusty, please wipe gently with absorbent cotton or other soft materials like chamois soaks with petroleum benzine. Normal-hexane is recommended for cleaning the adhesives used to attach front / rear polarizers. Do not use acetone, toluene and alcohol because they cause chemical damage to the polarizer.
- (8) Wipe off saliva or water drops as soon as possible. Their long time contact with polarizer causes deformations and color fading.
- (9) Do not open the case because inside circuits do not have sufficient strength.

### 9-2. Operating Precautions

- (1) The spike noise causes the mis-operation of circuits. It should be lower than following voltage :  
 $V = \pm 200\text{mV}$  (Over and under shoot voltage)
- (2) Response time depends on the temperature. (In lower temperature, it becomes longer.)
- (3) Brightness depends on the temperature. (In lower temperature, it becomes lower.)  
And in lower temperature, response time (required time that brightness is stable after turned on) becomes longer.
- (4) Be careful for condensation at sudden temperature change. Condensation makes damage to polarizer or electrical contacted parts. And after fading condensation, smear or spot will occur.
- (5) When fixed patterns are displayed for a long time, remnant image is likely to occur.
- (6) Module has high frequency circuits. Sufficient suppression to the electromagnetic interference shall be done by system manufacturers. Grounding and shielding methods may be important to minimize the interference.
- (7) Please do not give any mechanical and/or acoustical impact to LCM. Otherwise, LCM can't be operated its full characteristics perfectly.
- (8) A screw which is fastened up the steels should be a machine screw.  
(if not, it causes metallic foreign material and deal LCM a fatal blow)
- (9) Please do not set LCD on its edge.

## Product Specification

### 9-3. Electrostatic Discharge Control

Since a module is composed of electronic circuits, it is not strong to electrostatic discharge. Make certain that treatment persons are connected to ground through wrist band etc. And don't touch interface pin directly.

### 9-4. Precautions for Strong Light Exposure

Strong light exposure causes degradation of polarizer and color filter.

### 9-5. Storage

When storing modules as spares for a long time, the following precautions are necessary.

- (1) Store them in a dark place. Do not expose the module to sunlight or fluorescent light. Keep the temperature between 5°C and 35°C at normal humidity.
- (2) The polarizer surface should not come in contact with any other object.  
It is recommended that they be stored in the container in which they were shipped.

### 9-6. Handling Precautions for Protection Film

- (1) The protection film is attached to the bezel with a small masking tape.  
When the protection film is peeled off, static electricity is generated between the film and polarizer.  
This should be peeled off slowly and carefully by people who are electrically grounded and with well ion-blown equipment or in such a condition, etc.
- (2) When the module with protection film attached is stored for a long time, sometimes there remains a very small amount of glue still on the bezel after the protection film is peeled off.
- (3) You can remove the glue easily. When the glue remains on the bezel surface or its vestige is recognized, please wipe them off with absorbent cotton waste or other soft material like chamois soaked with normal-hexane.