

Product Specification

# SPECIFICATION FOR APPROVAL

- ( ) Preliminary Specification
- ( ) Final Specification

<b>Title</b>	<b>37.0" WXGA TFT LCD</b>
--------------	---------------------------

BUYER	
MODEL	

SUPPLIER	LG.Philips LCD Co., Ltd.
*MODEL	LC370WX1
SUFFIX	SLA1

\*When you obtain standard approval, please use the above model name without suffix

APPROVED BY	SIGNATURE DATE
/	
/	
/	

APPROVED BY	SIGNATURE DATE
J.H. Yoon / Senior Manager	
<b>REVIEWED BY</b>	
S.S. Kim / Manager	
<b>PREPARED BY</b>	
S.Y. Choi / Engineer	

Please return 1 copy for your confirmation with your signature and comments.

**TV Product Development Dept.  
LG. Philips LCD Co., Ltd**

## Product Specification

Contents

Number	ITEM	Page
	COVER	1
	CONTENTS	2
	RECORD OF REVISIONS	3
1	GENERAL DESCRIPTION	4
2	ABSOLUTE MAXIMUM RATINGS	5
3	ELECTRICAL SPECIFICATIONS	6
3-1	ELECTRICAL CHARACTERISTICS	6
3-2	INTERFACE CONNECTIONS	8
3-3	SIGNAL TIMING SPECIFICATIONS	12
3-4	SIGNAL TIMING WAVEFORMS	13
3-5	COLOR INPUT DATA REFERENCE	14
3-6	POWER SEQUENCE	15
4	OPTICAL SPECIFICATIONS	17
5	MECHANICAL CHARACTERISTICS	21
6	RELIABILITY	24
7	INTERNATIONAL STANDARDS	25
7-1	SAFETY	25
7-2	EMC	25
8	PACKING	26
8-1	DESIGNATION OF LOT MARK	26
8-2	PACKING FORM	26
9	PRECAUTIONS	27
9-1	MOUNTING PRECAUTIONS	27
9-2	OPERATING PRECAUTIONS	27
9-3	ELECTROSTATIC DISCHARGE CONTROL	28
9-4	PRECAUTIONS FOR STRONG LIGHT EXPOSURE	28
9-5	STORAGE	28
9-6	HANDLING PRECAUTIONS FOR PROTECTION FILM	28



## Product Specification

## 1. General Description

LC370WX1 is a Color Active Matrix Liquid Crystal Display with an integral External Electrode Fluorescent Lamp (EEFL) backlight system. The matrix employs a-Si Thin Film Transistor as the active element. It is a transmissive type display operating in the normally black mode. It has a 37.02 inch diagonally measured active display area with WXGA resolution (768 vertical by 1366 horizontal pixel array). Each pixel is divided into Red, Green and Blue sub-pixels or dots which are arranged in vertical stripes. Gray scale or the luminance of the sub-pixel color is determined with a 8-bit gray scale signal for each dot, thus presenting a palette of more than 16.7M(true) colors.

It has been designed to apply the 8-bit 1 port LVDS interface.

It is intended to support LCD TV, PCTV where high brightness, super wide viewing angle, high color gamut, high color depth and fast response time are important.

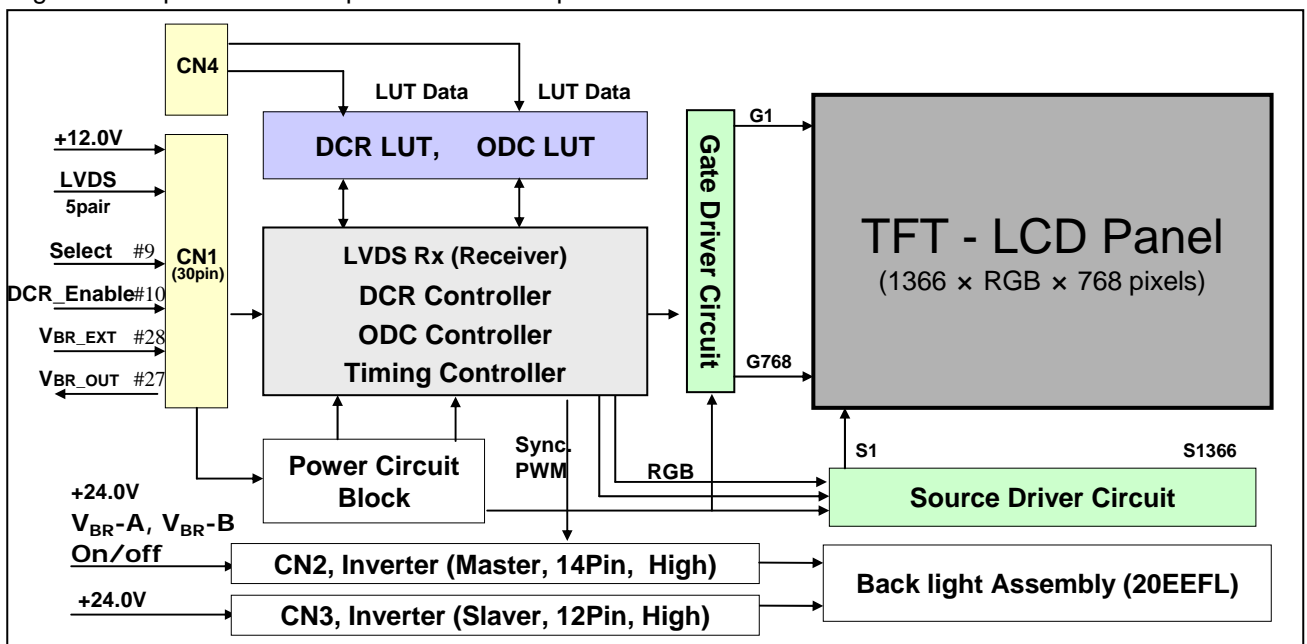

## General Features

Active Screen Size	37.02 inches(940.3mm) diagonal
Outline Dimension	877.0mm(H) x 516.8mm(V) x 55.5mm(D) (Typ.)
Pixel Pitch	0.200mm x 0.600mm x RGB
Pixel Format	1366 horiz. by 768 vert. pixels RGB stripe arrangement
Color Depth	8-bit, 16.7 M colors
Luminance, White	500 cd/m <sup>2</sup> (Center 1 point Typ.)
Viewing Angle (CR>10)	Viewing angle free ( R/L 178(Typ.), U/D 178(Typ.))
Power Consumption	Total 126Watt (Typ.) (Logic=4.8W, B/L=120W [I <sub>LAMP</sub> =120mA] )
Weight	9,500g (Typ.)
Display Operating Mode	Transmissive mode, normally black
Surface Treatment	Hard coating(3H), Anti-glare treatment of the front polarizer

## Product Specification

## 2. Absolute Maximum Ratings

The followings are maximum values which, if exceeded, may cause faulty operation or damage to the unit.

**Table 1. ABSOLUTE MAXIMUM RATINGS**

Parameter		Symbol	Value		Unit	Remark
			Min	Max		
Power Input Voltage	LCM	VLCD	-0.3	14.0	VDC	at 25 ± 2 °C
	Backlight inverter	VBL	21.6	27.0	VDC	When operating
Option Input Voltage		VI	-0.3	3.6	VDC	#9, #10 Pin
ON/OFF Control Voltage		VON/OFF	-0.30	5.5	VDC	
Brightness Control Voltage		VBR_A, VBR_B	-0.3	5.0	VDC	
Operating Temperature		TOP	0	40		Note 1 Note 2
Storage Temperature		TST	-20	50		
Operating Ambient Humidity		HOP	10	90	%RH	
Storage Humidity		HST	10	90	%RH	

Note : 1. Temperature and relative humidity range are shown in the figure below.

Wet bulb temperature should be 39 °C Max. and no condensation of water.

2. Gravity mura can be guaranteed under 40 condition.

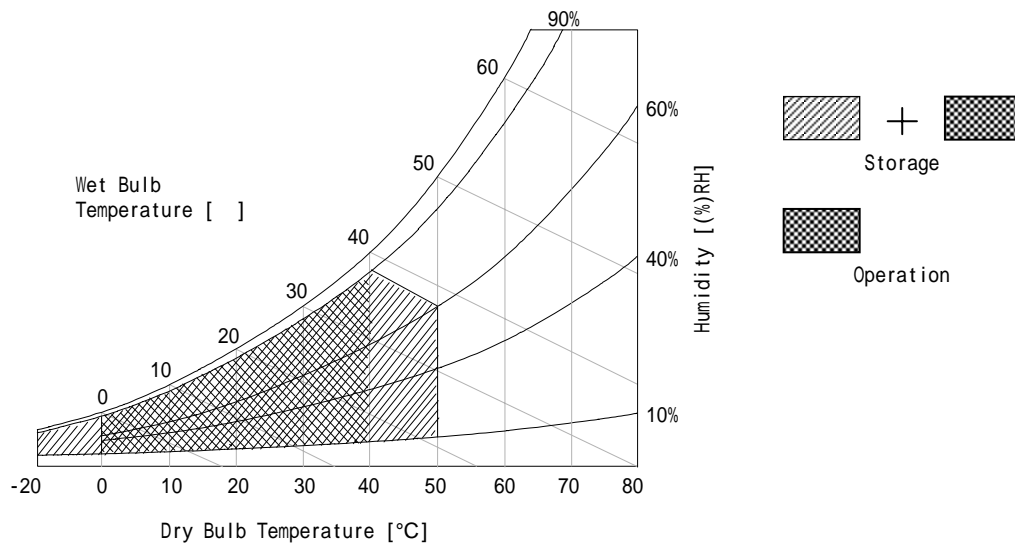

## Product Specification

### 3. Electrical Specifications

#### 3-1. Electrical Characteristics

It requires two power inputs. One is employed to power the LCD electronics and to drive the TFT array and liquid crystal. The other input power for the EEFL/Backlight is to power inverter.

**Table 2\_1. ELECTRICAL CHARACTERISTICS**

Parameter	Symbol	Value			Unit	Note
		Min	Typ	Max		
MODULE :						
Power Input Voltage	VLCD	11.4	12.0	12.6	VDC	
Permissible Input Ripple Voltage	VRP	-	-	200	mVP-P	
Option Input Voltage	High threshold	VIH	2.3	-	VDC	
	Low threshold	VIL	0	-	0.7	VDC
Power Input Current	ILCD	-	400	500	mA	1
		-	535	785	mA	2
Power Consumption	PLCD	-	4.8	6.0	Watt	1
Rush current	IRUSH	-	-	3.5	A	3

Note :

1. The specified current and power consumption are under the  $V_{LCD}=12.0V$ ,  $25 \pm 2^{\circ}C$ ,  $f_V=60Hz$  condition whereas mosaic pattern(8 x 6) is displayed and  $f_V$  is the frame frequency.
2. The current is specified at the maximum current pattern.
3. The duration of rush current is about 2ms and rising time of power Input is 1ms(min.).

White : 255Gray

Black : 0Gray

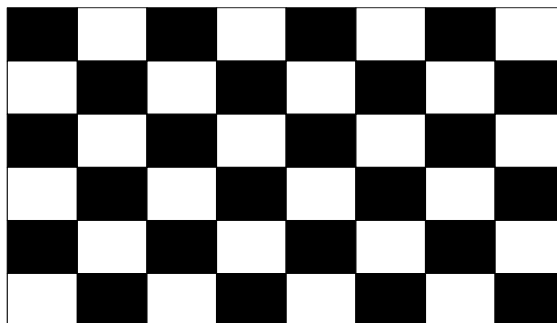

Mosaic Pattern(8 x 6)

## Product Specification

Table 2\_2. ELECTRICAL CHARACTERISTICS

Parameter		Symbol	Value			Unit	Note	
			Min	Typ	Max			
Inverter :								
Power Input Voltage		V <sub>BL</sub>	22.8	24.0	25.2	V <sub>DC</sub>	1	
Power Input Voltage Ripple			-	-	400	mVp-p		
Power Input Current	Operating	I <sub>BL</sub>	-	5.0	5.5	A	1	
	Turn on	I <sub>BL</sub>	-	5.5	6.0	A	1, 2	
Power Consumption		P <sub>BL</sub>	-	120	132	W	1	
Input Voltage for Control System Signals	Brightness Adjust	V <sub>BR_A</sub>	0	1.65	3.3	V <sub>DC</sub>	3	
		V <sub>BR_B</sub>	0	3.3	3.3			
	On/Off	On	V on	2.5	5.0	5.5	V <sub>DC</sub>	
		Off	V off	-0.3	0.0	0.5	V <sub>DC</sub>	
Lamp :								
Life Time			50,000	60,000	-	Hrs	4	

## Note :

- Electrical characteristics are determined after the unit has been 'ON' and stable for approximately 120Min at  $25 \pm 2^\circ\text{C}$  and  $V_{BR} = 3.3\text{V}$ .  
The specified current and power consumption are under the typical supply Input voltage, 24.0V.  
It is total power consumption.
- It is not inrush current, it is the current at turn on time.
- Brightness Control.  
These VBR Voltages control brightness.

Symbol	Description	Condition	Input Voltage	Brightness(%)	Note
V <sub>BR-A</sub>	Control the Analog Dimming	V <sub>BR-B</sub> =3.3V	0V	90%	-
			1.65V	100%	Typical
			3.3V	110%	-
V <sub>BR-B</sub>	Control the PWM Duty	V <sub>BR-A</sub> =1.65V (or Open)	0V	20~30%	Minimum
			3.3V	100%	Typical
			3.3V	100%	Maximum

- The life time is determined as the time at which luminance of the lamp is 50% compared to that of initial value at the typical lamp current on condition of continuous operating at  $25 \pm 2^\circ\text{C}$ .  
Specified value is when lamp is aligned horizontally.

## Product Specification

**3-2. Interface Connections**

This LCD employs two kinds of interface connection, a 30-pin connector is used for the module electronics and two 12-pin Connectors are used for the integral backlight system.

**3-2-1. LCD Module**

- LCD Connector(CN1) : FI-X30SSL-HF (Manufactured by JAE) or Equivalent
- Mating Connector : FI-X30C2L (Manufactured by JAE) or Equivalent

**Table 3. MODULE CONNECTOR(CN1) PIN CONFIGURATION**

Pin No.	Symbol	Description	Note
1	VLCD	Power Supply +12.0V	
2	VLCD	Power Supply +12.0V	
3	VLCD	Power Supply +12.0V	
4	VLCD	Power Supply +12.0V	
5	GND	Ground	
6	GND	Ground	
7	GND	Ground	
8	GND	Ground	
9	Select	Select LVDS Data format	1
10	DCR Enable	Dynamic CR Enable ( 'L' = Disable , 'H' = Enable )	2
11	GND	Ground	
12	RA-	LVDS Receiver Signal(-)	
13	RA+	LVDS Receiver Signal(+)	
14	GND	Ground	
15	RB-	LVDS Receiver Signal(-)	
16	RB+	LVDS Receiver Signal(+)	
17	GND	Ground	
18	RC-	LVDS Receiver Signal(-)	
19	RC+	LVDS Receiver Signal(+)	
20	GND	Ground	
21	RCLK-	LVDS Receiver Clock Signal(-)	
22	RCLK+	LVDS Receiver Clock Signal(+)	
23	GND	Ground	
24	RD-	LVDS Receiver Signal(-)	
25	RD+	LVDS Receiver Signal(+)	
26	GND	Ground	
27	VBR_OUT	VBR output form LCD module	
28	VBR_EXT	External VBR input from System to LCD module	
29	GND	Ground	
30	GND	Ground	3

Note: 1. If the pin no. 9 is Ground, Interface format is "LG", and if the pin no. 9 is Vcc(3.3V), Interface format is "DISM". See page 9 and 10.

2. When this pin is no connection or Ground, DCR is Disabled.

3. The pin no. 30 is necessary for LCD test.

When LVDS signals are abnormal operation more than 3-Vsync times and power 12V is supplied,

'Open' or 'Vcc' : LCD operate itself some test patterns.(AGP – Auto Generation Pattern)

'Ground' : LCD operate itself a black pattern. (NSB – No Signal Black)

LPL recommend 'Ground' for NSB.

4. All GND (ground) pins should be connected together, which should be also connected to the LCD module's metal frame.

5. All VLCD (power input) pins should be connected together.

6. Input Levels of LVDS signals are based on the IEA 664 Standard.



Product Specification

**Table 4. REQUIRED SIGNAL ASSIGNMENT FOR LVDS TRANSMITTER ( Pin9="L" or "Open" )**

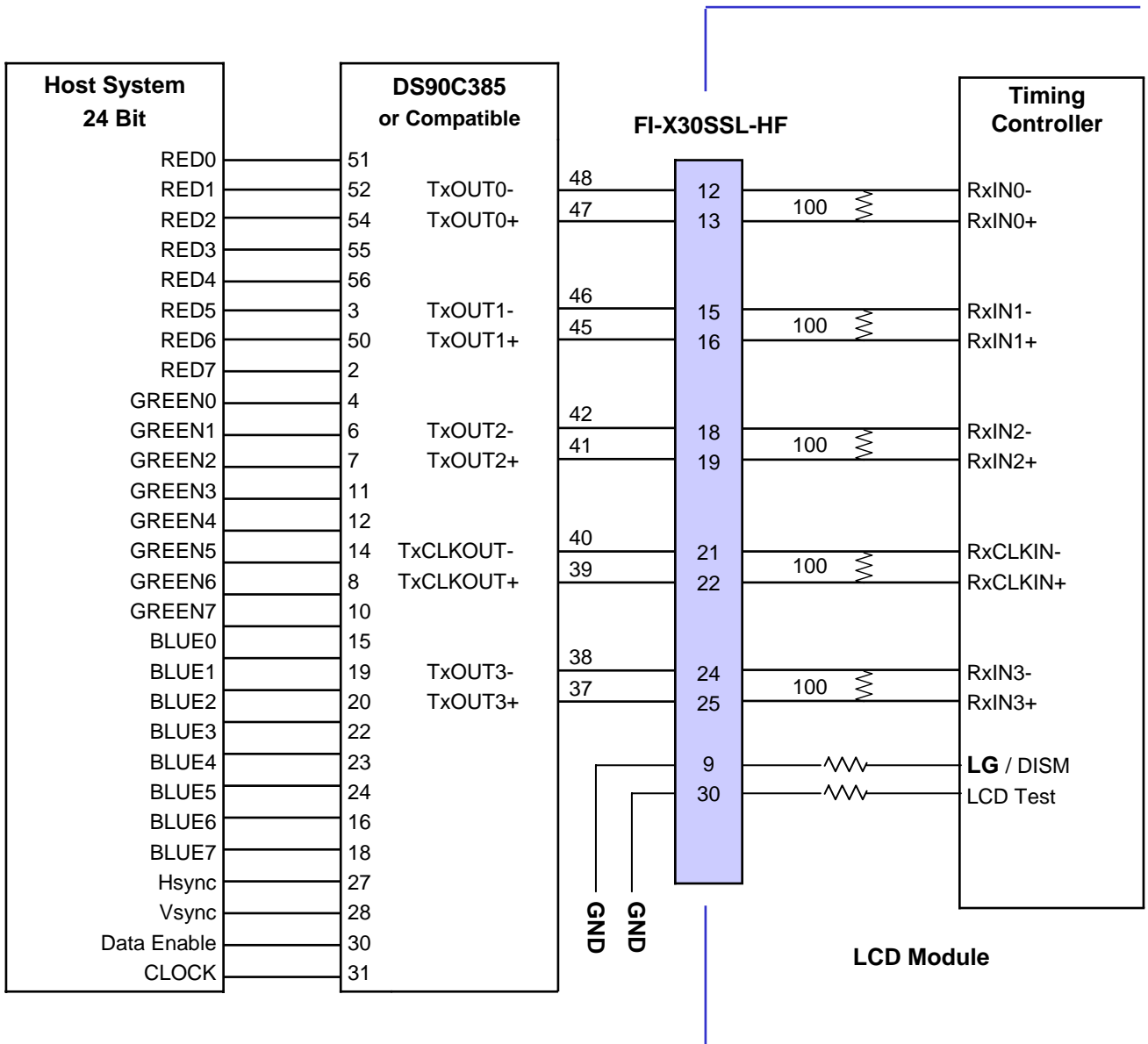

Note: 1. The LCD Module uses a 100 Ohm[ ] resistor between positive and negative lines of each receiver input.

2. Refer to LVDS Transmitter Data Sheet for detail descriptions. (DS90C385 or Compatible)

3. '7' means MSB and '0' means LSB at R,G,B pixel data.

Product Specification

**Table 5. REQUIRED SIGNAL ASSIGNMENT FOR LVDS TRANSMITTER ( Pin9="H" )**

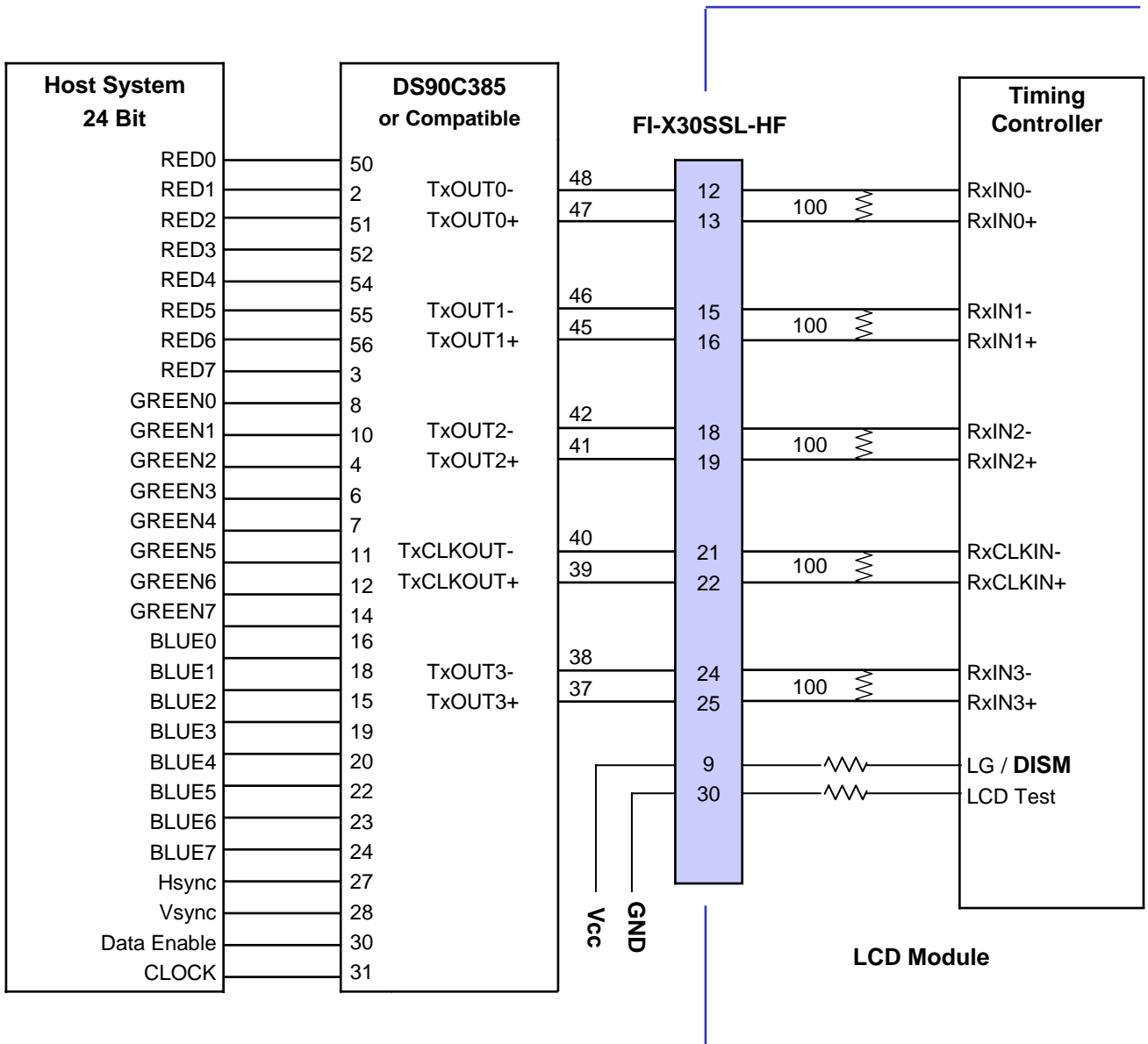

Note: 1. The LCD Module uses a 100 Ohm[ ] resistor between positive and negative lines of each receiver input.

2. Refer to LVDS Transmitter Data Sheet for detail descriptions. (DS90C385 or Compatible)

3. '7' means MSB and '0' means LSB at R,G,B pixel data.

Product Specification

**3-2-2. Backlight Inverter**

Input Connector

- Inverter Connector : S14B-PHA-SM3-TB and S12-PHA-SM3-TB(manufactured by JST) or Equivalent
- Mating Connector : PHR14 (JST) & PHR12 (JST) or Equivalent

**Table 6. INVERTER CONNECTOR PIN CONFIGURATION**

Pin	Symbol	Signal assignment		Note
		Master(CN2)	Slave(CN3)	
1	VBL	24V Power Input	24V Power Input	
2	VBL	24V Power Input	24V Power Input	
3	VBL	24V Power Input	24V Power Input	
4	VBL	24V Power Input	24V Power Input	
5	VBL	24V Power Input	24V Power Input	
6	GND	GROUND	GROUND	
7	GND	GROUND	GROUND	
8	GND	GROUND	GROUND	1
9	GND	GROUND	GROUND	
10	GND	GROUND	GROUND	
11	V <sub>BR-A</sub>	Analog dimming Control signal	Don't care	0V(min) ~ 3.3V(max)
12	ON / OFF	Backlight ON/OFF control	Don't care	ON : 2.4 ~ 5.0V OFF : 0.0 ~ 0.6V
13	V <sub>BR-B</sub>	PWM Duty Control signal	No Pin	0V(min) ~ 3.3V(max)
14	Status	Status	No pin	Upper 3.0V(Normal), Under 0.5V(Abnormal)

1. Connector

- 1) Connector(Receptacle)  
: S14B-PHA-SM3-TB (JST) & S12B-PHA-SM3-TB (JST)
- 2) Mating Connector(Plug)  
: PHR14 (JST) & PHR12 (JST)

\* JST : Japan solderless Terminal Co.,Ltd.

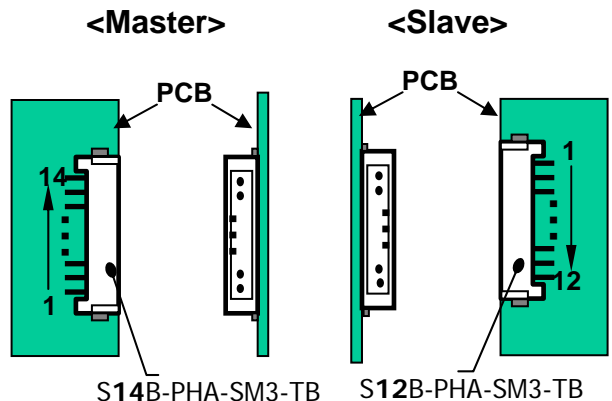

- Note :
1. GND should be connected to the LCD module's metal frame.
  2. Minimum Brightness : V<sub>BR</sub> = 0.0V  
Maximum Brightness : V<sub>BR</sub> = 3.3V
  3. V<sub>ON</sub> : 3.0 ~ 5.0V  
V<sub>OFF</sub> : -0.3 ~ 0.5V

## Product Specification

**3-3. Signal Timing Specifications**

This is the signal timing required at the input of LVDS Transmitter. All of the interface signal timing should be satisfied with the following specifications for it's proper operation.

**Table 7. TIMMING TABLE**

ITEM		Symbol	Min.	Typ.	Max.	Unit	Note
Clock	Frequency	$f_{CLK}$	63	72.3	80	MHz	
Hsync	Frequency	$f_H$	39	47.4	53	KHZ	
	Display Valid	$t_{HV}$	1366	1366	1366	Clks	
	Blank	$t_{HT}-t_{HV}$	80	162	474	Clks	
	Total	$t_{HT}$	1446	1528	1840	Clks	
Vsync	Frequency	$f_V$	47	60	63	HZ	PAL : 47~53Hz, NTSC : 57~63Hz
	Display Valid	$t_{VV}$	768	768	768	Lines	
	Blank	$t_{VT}-t_{VV}$	7	22	295	Lines	
	Total	$t_{VT}$	775	790	1063	Lines	

## Notes:

1. The performance of the electro-optical characteristics are may be influenced by variance of the vertical refresh rates.
2. Above timing table is only valid for DE Mode.

### 3-4. Signal Timing Waveforms

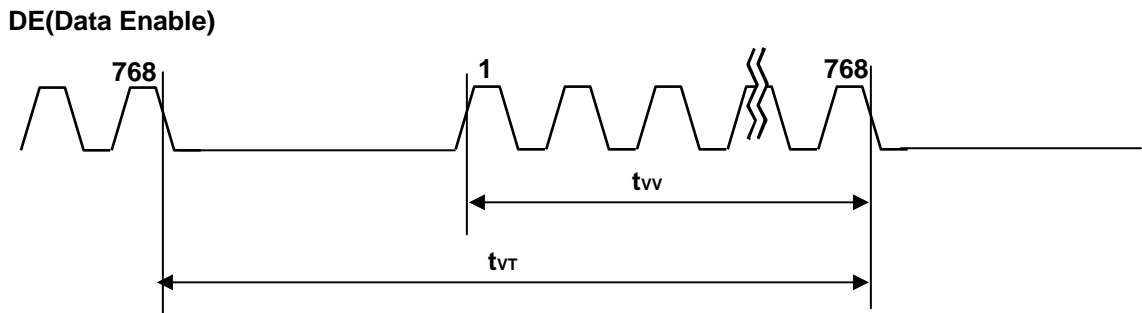
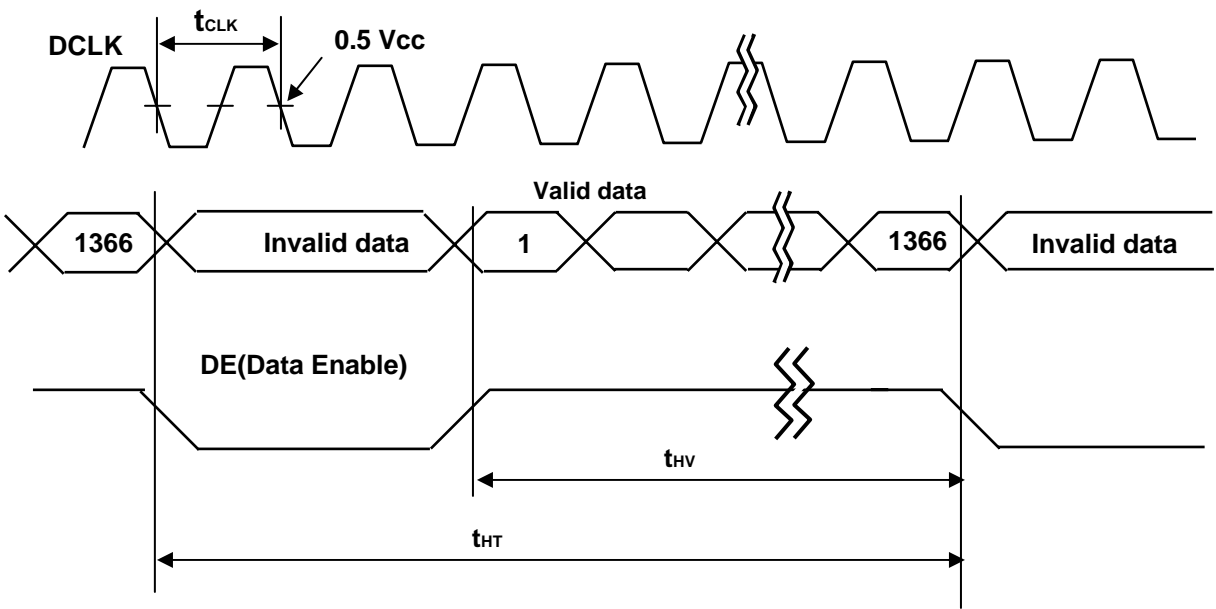
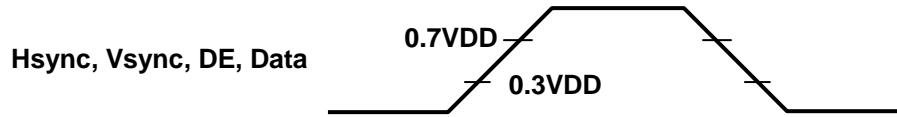



Product Specification

### 3-5. Color Data Reference

The brightness of each primary color(red,green,blue) is based on the 8-bit gray scale data input for the color the higher the binary input, the brighter the color. The table below provides a reference for color versus data input.

**Table 8. COLOR DATA REFERENCE**

Color		Input Color Data																							
		RED								GREEN								BLUE							
		MSB	LSB	MSB	LSB	MSB	LSB	MSB	LSB	MSB	LSB	MSB	LSB	MSB	LSB	MSB	LSB								
R7	R6	R5	R4	R3	R2	R1	R0	G7	G6	G5	G4	G3	G2	G1	G0	B7	B6	B5	B4	B3	B2	B1	B0		
Basic Color	Black	0	0	0	0	0	0	0	0	0	0	0	0	0	0	0	0	0	0	0	0	0	0	0	0
	Red (255)	1	1	1	1	1	1	1	1	0	0	0	0	0	0	0	0	0	0	0	0	0	0	0	0
	Green (255)	0	0	0	0	0	0	0	0	1	1	1	1	1	1	1	1	0	0	0	0	0	0	0	0
	Blue (255)	0	0	0	0	0	0	0	0	0	0	0	0	0	0	0	0	1	1	1	1	1	1	1	1
	Cyan	0	0	0	0	0	0	0	0	1	1	1	1	1	1	1	1	1	1	1	1	1	1	1	1
	Magenta	1	1	1	1	1	1	1	1	0	0	0	0	0	0	0	0	1	1	1	1	1	1	1	1
	Yellow	1	1	1	1	1	1	1	1	1	1	1	1	1	1	1	1	0	0	0	0	0	0	0	0
	White	1	1	1	1	1	1	1	1	1	1	1	1	1	1	1	1	1	1	1	1	1	1	1	1
RED	RED (000) Dark	0	0	0	0	0	0	0	0	0	0	0	0	0	0	0	0	0	0	0	0	0	0	0	0
	RED (001)	0	0	0	0	0	0	0	1	0	0	0	0	0	0	0	0	0	0	0	0	0	0	0	0
	...	...								...								...							
	RED (254)	1	1	1	1	1	1	1	0	0	0	0	0	0	0	0	0	0	0	0	0	0	0	0	0
	RED (255)	1	1	1	1	1	1	1	1	0	0	0	0	0	0	0	0	0	0	0	0	0	0	0	0
GREEN	GREEN (000) Dark	0	0	0	0	0	0	0	0	0	0	0	0	0	0	0	0	0	0	0	0	0	0	0	0
	GREEN (001)	0	0	0	0	0	0	0	0	0	0	0	0	0	0	0	1	0	0	0	0	0	0	0	0
	...	...								...								...							
	GREEN (254)	0	0	0	0	0	0	0	0	1	1	1	1	1	1	1	0	0	0	0	0	0	0	0	0
	GREEN (255)	0	0	0	0	0	0	0	0	1	1	1	1	1	1	1	1	0	0	0	0	0	0	0	0
BLUE	BLUE (000) Dark	0	0	0	0	0	0	0	0	0	0	0	0	0	0	0	0	0	0	0	0	0	0	0	0
	BLUE (001)	0	0	0	0	0	0	0	0	0	0	0	0	0	0	0	0	0	0	0	0	0	0	0	1
	...	...								...								...							
	BLUE (254)	0	0	0	0	0	0	0	0	0	0	0	0	0	0	0	0	1	1	1	1	1	1	1	0
	BLUE (255)	0	0	0	0	0	0	0	0	0	0	0	0	0	0	0	0	1	1	1	1	1	1	1	1

## Product Specification

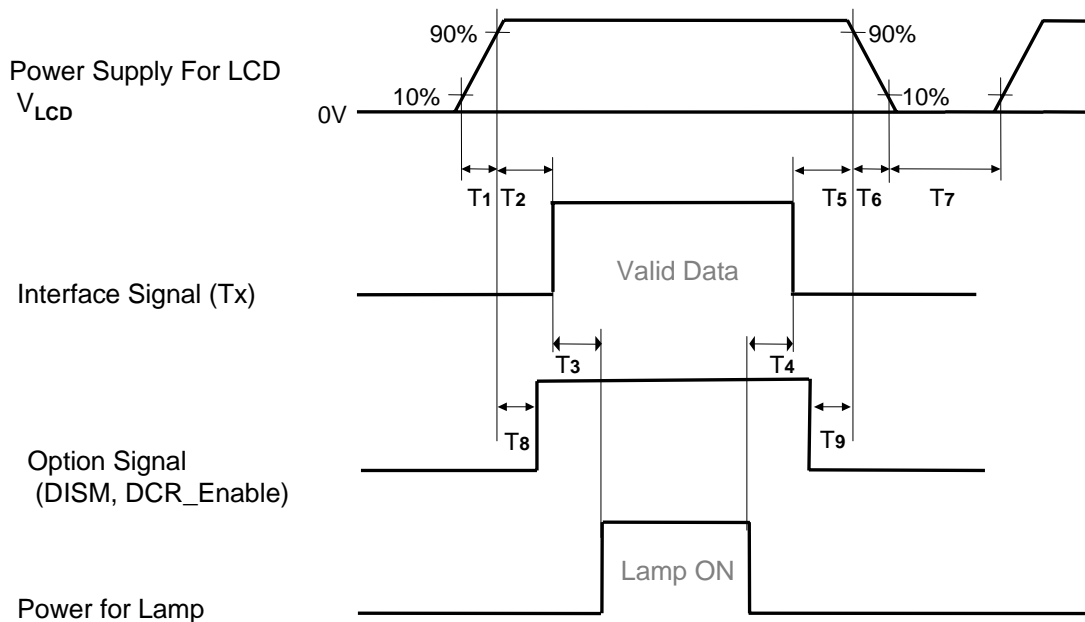
**3-6. Power Sequence****Table 9. POWER SEQUENCE**

Parameter	Value			Unit
	Min	Typ	Max	
T1	1.0	-	20	ms
T2	5.0	-	50	ms
T3	200	-	-	ms
T4	200	-	-	ms
T5	0.5	-	50	ms
T6	-	-	300	ms
T7	2.0	-	-	s
T8	0 < T8 < T2			ms
T9	0 < T9 < T5			ms

- Note :
1. Please avoid floating state of interface signal at invalid period.
  2. When the interface signal is invalid, be sure to pull down the power supply  $V_{LCD}$  to 0V.
  3. The case when the T2/T5 exceed maximum specification, it operates protection pattern(Black pattern) till valid signal inputted. There is no reliability problem.
  4. The T3/T4 is recommended value, the case when failed to meet a minimum specification, abnormal display would be shown. There is no reliability problem.
  5. If the on time of option signal(DISM or AI\_Enable) precedes the on time of Power( $V_{LCD}$ ), check the LCD logic Power( $V_{cc}$ ) is under 0.8V, otherwise it will be happened abnormal display.

Product Specification

3-6-2. Power Sequence for Inverter

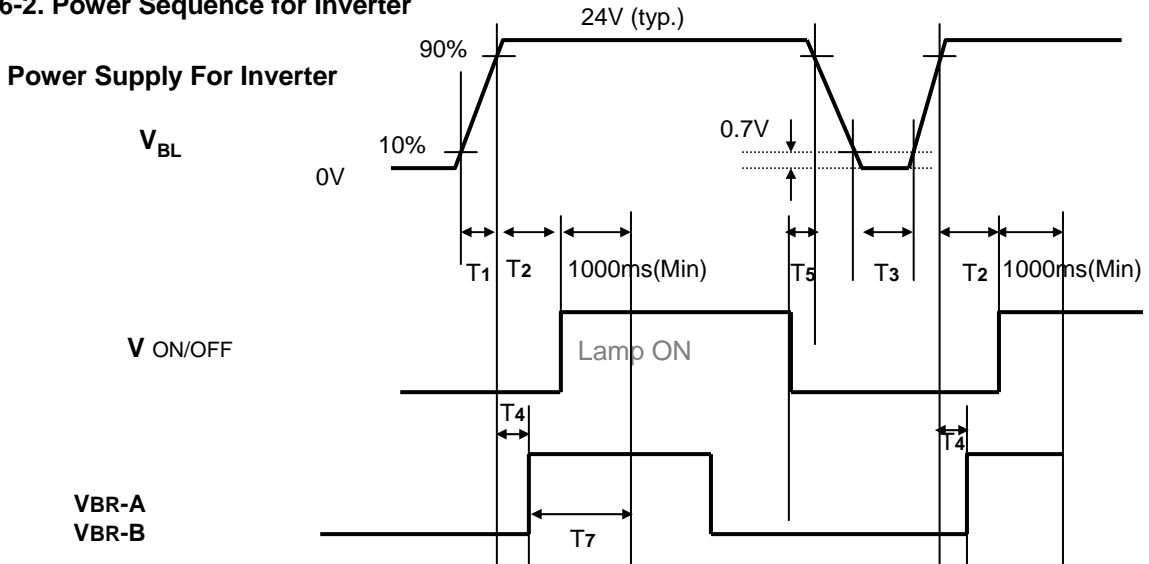

3-6-3. Deep condition for Inverter

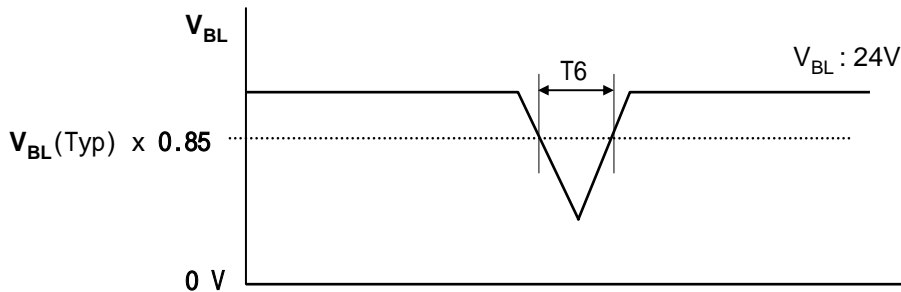

Table 10. Power Sequence for Inverter

Parameter	Values			Units	Remarks
	Min	Typ	Max		
T1	20	-	-	ms	1
T2	500	-	-	ms	2
T3	200	-	-	ms	
T4	0	-	-	ms	3
T5	10	-	-	ms	
T6	-	-	10	ms	$V_{BL}(Typ) \times 0.85$
T7	1000	-	-	ms	4

- Note :
1. T1 describes rising time of 0V to 24V and is not applied at restarting time.
  2. When  $V_{BL}$  (24V) is supplied always, there is no reliability problem.
  3. T4(max) is less than T2.
  4. In T7 section, Vbr-B should be 3.3V in T4 section and Vbr-A recommend 1.65V.



## Product Specification

#### 4. Optical Specification

Optical characteristics are determined after the unit has been 'ON' for 30min in a dark environment at  $25 \pm 2^\circ\text{C}$ . The values specified are at an approximate distance 50cm from the LCD surface at a viewing angle of  $\Phi$  and  $\theta$  equal to  $0^\circ$ .

It is presented additional information concerning the measurement equipment and method in FIG. 1.

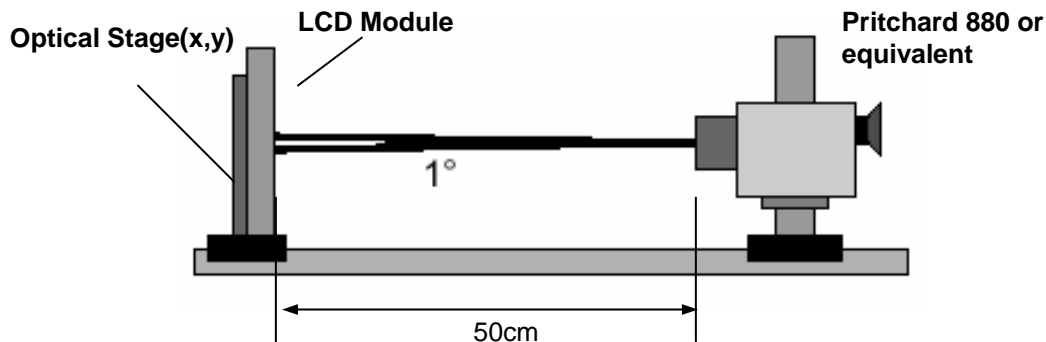

FIG. 1 Optical Characteristic Measurement Equipment and Method

Table 11. OPTICAL CHARACTERISTICS

$T_a = 25 \pm 2^\circ\text{C}$ ,  $V_{LCD} = 12.0\text{V}$ ,  $f_v = 60\text{Hz}$ ,  $D_{clk} = 72\text{MHz}$ ,  $V_{BR} = 3.3\text{V}$   
Dynamic CR : Disabled

Parameter	Symbol	Value			Unit	Note	
		Min	Typ	Max			
Contrast Ratio	CR	700	1000			1	
	CR <sub>D</sub> (With AI)	1400	2000				
Surface Luminance, white	L <sub>WH</sub>	400	500		cd/m <sup>2</sup>	2	
Luminance Variation	$\delta_{\text{WHITE}}$ 5P			1.3		3	
Response Time	<b>Gray to Gray</b>	-	6	10	mx		
Color Coordinates [CIE1931]	RED	R <sub>x</sub>	0.640				
		R <sub>y</sub>	0.341				
	GREEN	G <sub>x</sub>	0.287				
		G <sub>y</sub>	0.615				
	BLUE	B <sub>x</sub>	0.145				
		B <sub>y</sub>	0.061				
	WHITE	W <sub>x</sub>	0.285				
	W <sub>y</sub>	0.293					
Viewing Angle (CR>10)							
	x axis, right( $\phi=0^\circ$ )	$\theta_r$	85	89	-	degree	5
	x axis, left ( $\phi=180^\circ$ )	$\theta_l$	85	89	-		
	y axis, up ( $\phi=90^\circ$ )	$\theta_u$	85	89	-		
	y axis, down ( $\phi=270^\circ$ )	$\theta_d$	85	89	-		
Gray Scale							6

## Product Specification

Notes 1. Contrast Ratio(CR) is defined mathematically as :

$$\text{Contrast Ratio} = \frac{\text{Surface Luminance with all white pixels}}{\text{Surface Luminance with all black pixels}}$$

It is measured at the center point(1).

CRD is measured when Dynamic CR is enabled.

2. Surface luminance is luminance value at the center point across the LCD surface 50cm from the surface with all pixels displaying white.  
For more information, see FIG 2.
3. The variation in surface luminance ,  $\delta$  WHITE is defined as :  

$$\delta \text{ WHITE}(5P) = \text{Maximum}(L_{on1}, L_{on2}, L_{on3}, \dots, L_{on5}) / \text{Minimum}(L_{on1}, L_{on2}, L_{on3}, \dots, L_{on5})$$
 Where  $L_{on1}$  to  $L_{on5}$  are the luminance with all pixels displaying white at 5 locations .  
For more information, see FIG 2.
4. Response time is the time required for the display to transition from G(N) to G(M) (Rise Time,  $Tr_R$ ) and from G(M) to G(N) (Decay Time,  $Tr_D$ ). For additional information see the FIG. 3. ( $N < M$ )
5. Viewing angle is the angle at which the contrast ratio is greater than 10. The angles are determined for the horizontal or x axis and the vertical or y axis with respect to the z axis which is normal to the LCD surface. For more information, see FIG 4.
6. Gray scale specification  
Gamma Value is approximately 2.2.  
For more information, see Table 12.

**Table 12. GRAY SCALE SPECIFICATION**

Gray Level	Luminance [%] (Typ) Without DCR	Luminance [%] (Typ) With DCR
L0	0.10	0.05
L15	0.32	0.33
L31	1.10	1.10
L47	2.60	2.81
L63	4.90	5.40
L79	8.10	8.5
L95	12.1	12.4
L111	16.7	16.7
L127	21.6	21.3
L143	28.0	27.4
L159	35.4	34.6
L175	43.9	43.0
L191	53.3	52.4
L207	64.1	63.0
L223	75.8	74.5
L239	88.0	86.8
L255	100	100

Product Specification

Measuring point for surface luminance & measuring point for luminance variation

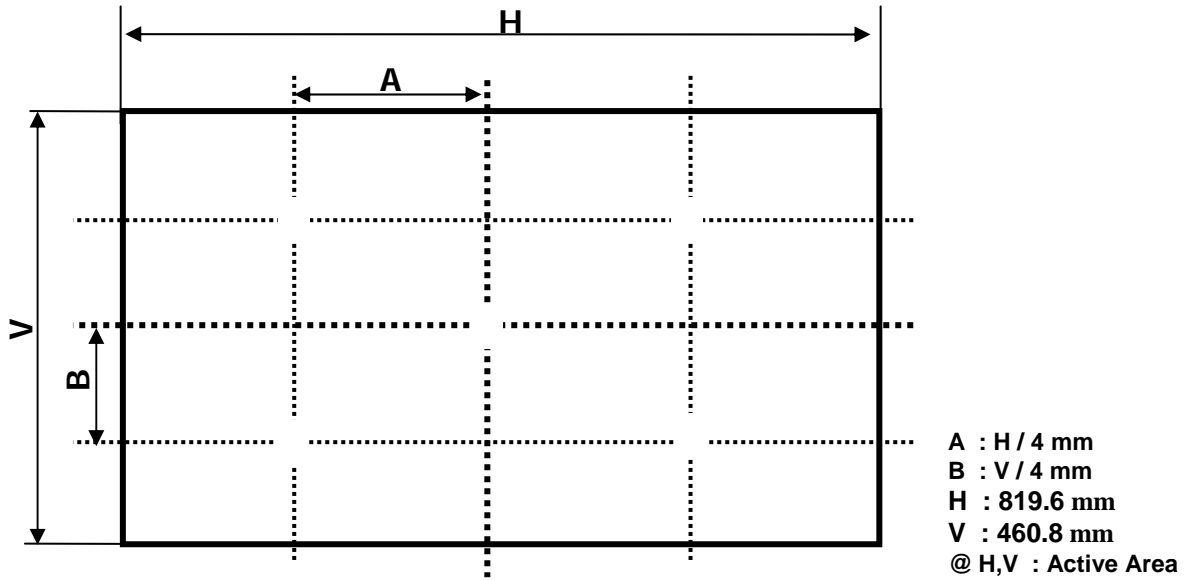

FIG. 2 Measure Point for Luminance

Response time is defined as the following figure and shall be measured by switching the input signal for “Gray(N)” and “Gray(M)”.

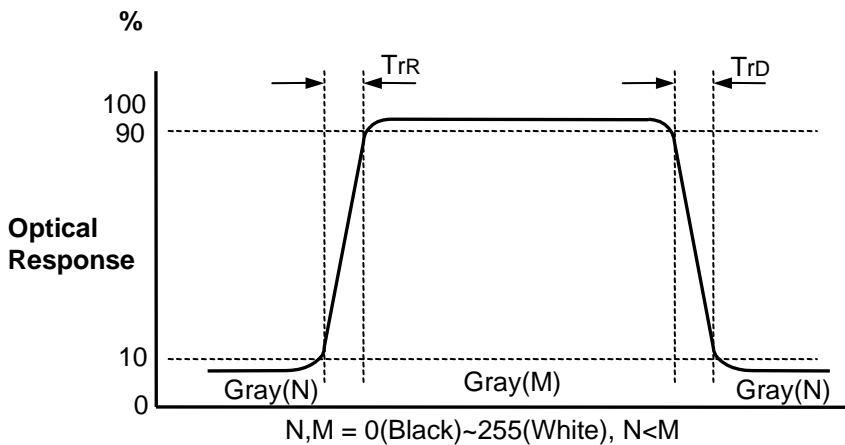

FIG. 3 Response Time

Product Specification

Dimension of viewing angle range

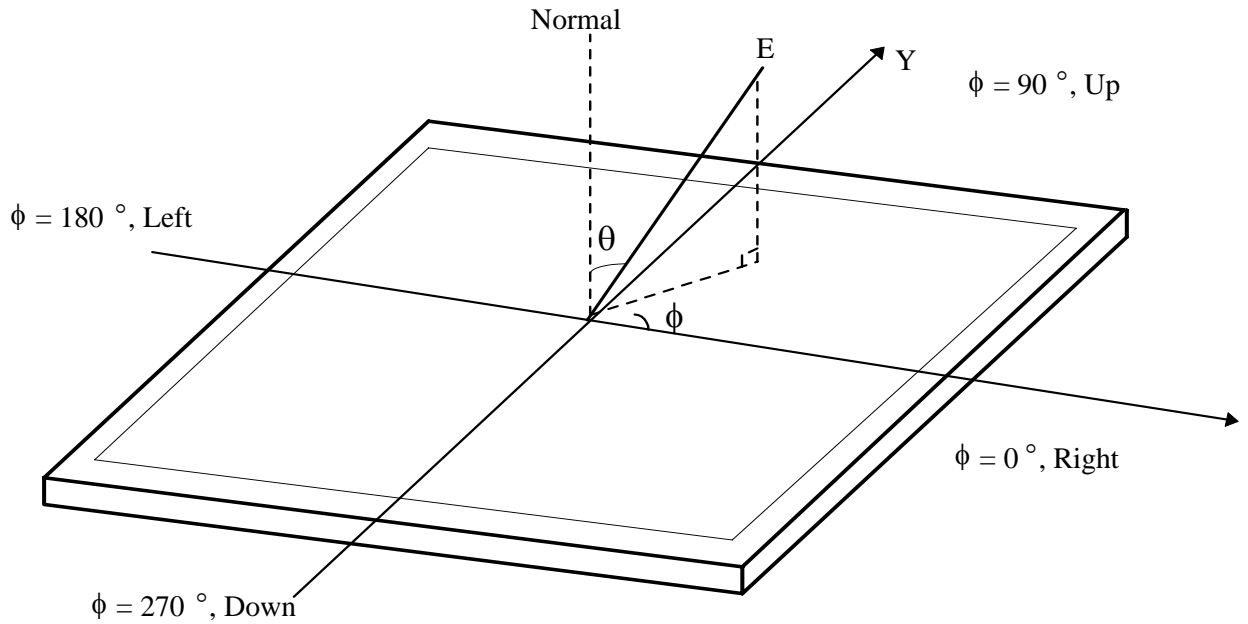

FIG. 4 Viewing angle

## Product Specification

## 5. Mechanical Characteristics

The following items provide general mechanical characteristics. In addition the figures in the next page are detailed mechanical drawing of the LCD module.

**Table 13. MECHANICAL CHARACTERISTICS**

Outline Dimension	Horizontal	877.0 mm
	Vertical	516.8 mm
	Depth	55.5 mm
Bezel Area	Horizontal	828.6mm
	Vertical	469.8mm
Active Display Area	Horizontal	819.6mm
	Vertical	460.8mm
Weight	9,500 (Typ.)/10,000(Max)	
Surface Treatment	Hard coating(3H) Anti-glare treatment of the front polarizer	

Note : Please refer to a mechanic drawing in terms of tolerance at the next page.

Product Specification

<FRONT VIEW>

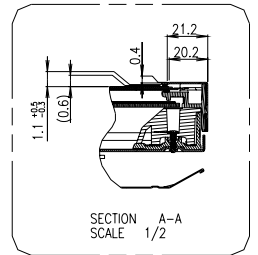
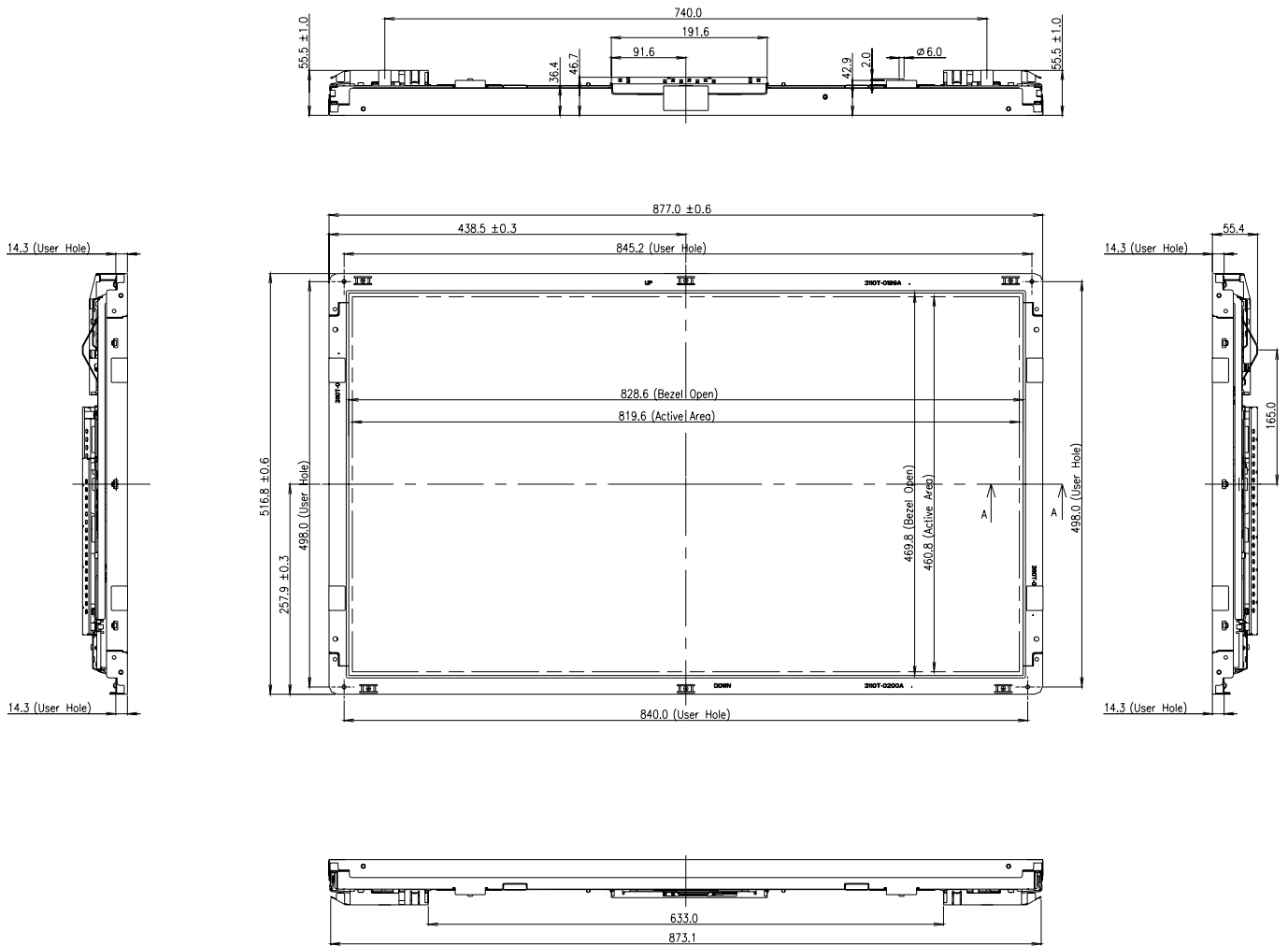

Product Specification

<REAR VIEW>

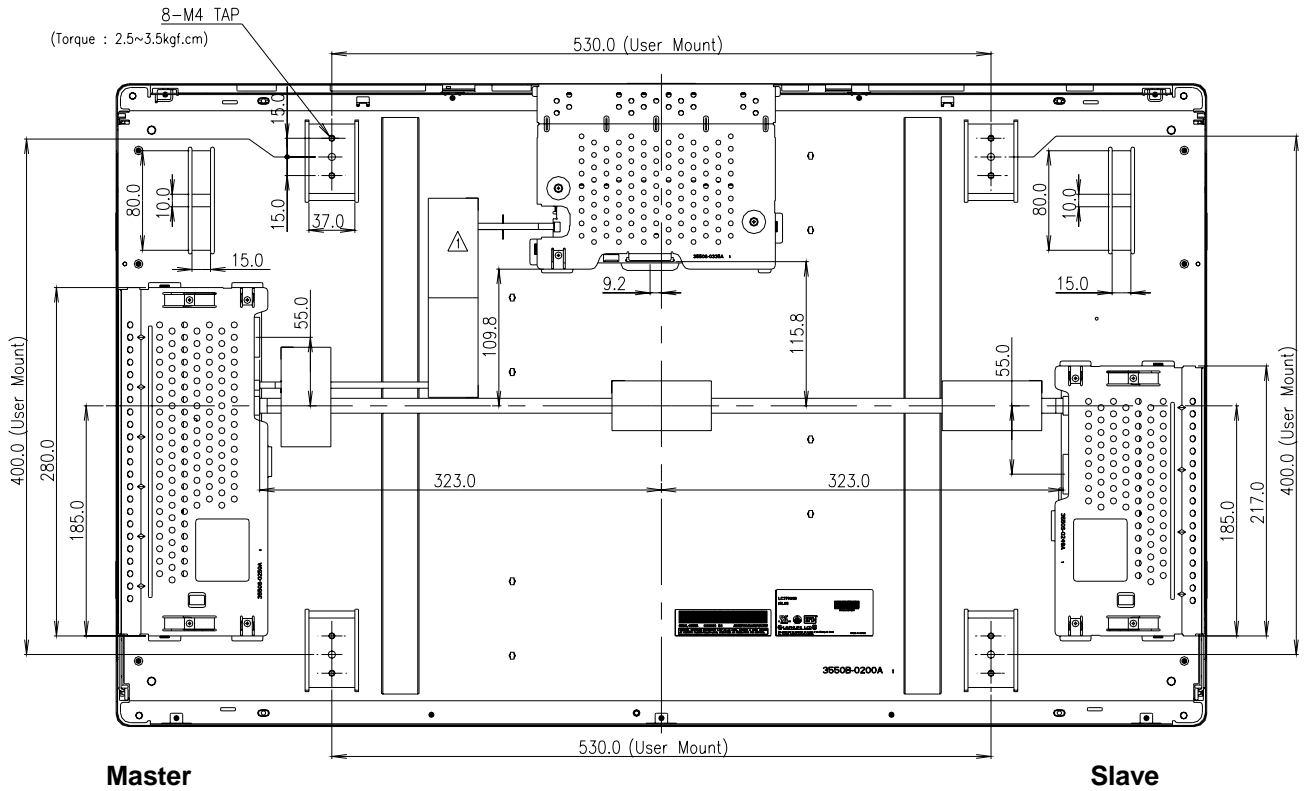

NOTES

1. Unspecified tolerances are to be  $\pm 0.5\text{mm}$ .
2. This drawing is only preliminary data and can be changed without previous notice.
3. Tilt and partial disposition tolerance of display area are as following.
  - (1) X-Direction : IA-BI  $\leq 1.5\text{mm}$
  - (2) Y-Direction : IC-DI  $\leq 1.5\text{mm}$

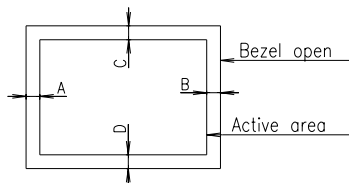

## Product Specification

## 6. Reliability

**Table 14. ENVIRONMENT TEST CONDITION**

No.	Test Item	Condition
1	High temperature storage test	Ta= 50°C 240h
2	Low temperature storage test	Ta= -20°C 240h
3	High temperature operation test	Ta= 40°C 50%RH 240h
4	Low temperature operation test	Ta= 0°C 240h
5	Vibration test (non-operating)	Wave form : random Vibration level : 1.0G RMS Bandwidth : 10-500Hz Duration : X,Y,Z, 10 min One time each direction
6	Shock test (non-operating)	Shock level : 100G Waveform : half sine wave, 2ms Direction : ± X, ± Y, ± Z One time each direction
7	Humidity condition Operation	Ta= 40 °C, 90%RH
8	Altitude operating storage / shipment	0 - 14,000 feet(4267.2m) 0 - 40,000 feet(12192m)



## 7. International Standards

### 7-1. Safety

- a) UL 60065, 7<sup>th</sup> Edition, dated June 30, 2003, Underwriters Laboratories, Inc., Standard for Audio, Video and Similar Electronic Apparatus.
- b) CAN/CSA C22.2, No. 60065:03, Canadian Standards Association, Standard for Audio, Video and Similar Electronic Apparatus.
- c) IEC60065:2001, 7<sup>th</sup> Edition CB-scheme and EN 60065:2002, Safety requirements for Audio, Video and Similar Electronic Apparatus..

### 7-2. EMC

- a) ANSI C63.4 "Methods of Measurement of Radio-Noise Emissions from Low-Voltage Electrical and Electrical Equipment in the Range of 9kHz to 40GHz. "American National Standards Institute(ANSI), 1992
- b) CISPR22 "Limits and Methods of Measurement of Radio Interface Characteristics of Information Technology Equipment." International Special Committee on Radio Interference.
- c) EN 55022 "Limits and Methods of Measurement of Radio Interface Characteristics of Information Technology Equipment." European Committee for Electrotechnical Standardization.(CENELEC), 1998 ( Including A1: 2000 )

## Product Specification

**8. Packing****8-1. Designation of Lot Mark**

a) Lot Mark

A	B	C	D	E	F	G	H	I	J	K	L	M
---	---	---	---	---	---	---	---	---	---	---	---	---

A,B,C : SIZE(INCH)  
E : MONTH

D : YEAR  
F ~ M : SERIAL NO.

Note

## 1. YEAR

Year	2001	2002	2003	2004	2005	2006	2007	2008	2009	2010	2011
Mark	1	2	3	4	5	6	7	8	9	0	1

## 2. MONTH

Month	Jan	Feb	Mar	Apr	May	Jun	Jul	Aug	Sep	Oct	Nov	Dec
Mark	1	2	3	4	5	6	7	8	9	A	B	C

## 3. FACTORY CODE

Factory Code	Gumi	Nanjing	Paju
Mark	K	C	P

b) Location of Lot Mark

Serial NO. is printed on the label. The label is attached to the backside of the LCD module.  
This is subject to change without prior notice.

**8-2. Packing Form**

a) Package quantity in one box : 5 pcs

b) Box Size : 973mm X 493mm X 577mm

## Product Specification

## 9. Precautions

Please pay attention to the followings when you use this TFT LCD module.

### 9-1. Mounting Precautions

- (1) You must mount a module using holes arranged in four corners or four sides.
- (2) You should consider the mounting structure so that uneven force (ex. Twisted stress) is not applied to the module. And the case on which a module is mounted should have sufficient strength so that external force is not transmitted directly to the module.
- (3) Please attach the surface transparent protective plate to the surface in order to protect the polarizer. Transparent protective plate should have sufficient strength in order to resist external force.
- (4) You should adopt radiation structure to satisfy the temperature specification.
- (5) Acetic acid type and chlorine type materials for the cover case are not desirable because the former generates corrosive gas of attacking the polarizer at high temperature and the latter causes circuit break by electro-chemical reaction.
- (6) Do not touch, push or rub the exposed polarizers with glass, tweezers or anything harder than HB pencil lead. And please do not rub with dust clothes with chemical treatment. Do not touch the surface of polarizer for bare hand or greasy cloth.(Some cosmetics are detrimental to the polarizer.)
- (7) When the surface becomes dusty, please wipe gently with absorbent cotton or other soft materials like chamois soaks with petroleum benzene. Normal-hexane is recommended for cleaning the adhesives used to attach front / rear polarizers. Do not use acetone, toluene and alcohol because they cause chemical damage to the polarizer.
- (8) Wipe off saliva or water drops as soon as possible. Their long time contact with polarizer causes deformations and color fading.
- (9) Do not open the case because inside circuits do not have sufficient strength.

### 9-2. Operating Precautions

- (1) The spike noise causes the mis-operation of circuits. It should be lower than following voltage :  
 $V = \pm 200\text{mV}$  (Over and under shoot voltage)
- (2) Response time depends on the temperature.(In lower temperature, it becomes longer.)
- (3) Brightness depends on the temperature. (In lower temperature, it becomes lower.)  
And in lower temperature, response time(required time that brightness is stable after turned on) becomes longer.
- (4) Be careful for condensation at sudden temperature change. Condensation makes damage to polarizer or electrical contacted parts. And after fading condensation, smear or spot will occur.
- (5) When fixed patterns are displayed for a long time, remnant image is likely to occur.
- (6) Module has high frequency circuits. Sufficient suppression to the electromagnetic interference shall be done by system manufacturers. Grounding and shielding methods may be important to minimized the interference.
- (7) Please do not give any mechanical and/or acoustical impact to LCM. Otherwise, LCM can't be operated its full characteristics perfectly.
- (8) A screw which is fastened up the steels should be a machine screw.  
(if not, it causes metallic foreign material and deal LCM a fatal blow)
- (9) Please do not set LCD on its edge.

## Product Specification

### 9-3. Electrostatic Discharge Control

Since a module is composed of electronic circuits, it is not strong to electrostatic discharge. Make certain that treatment persons are connected to ground through wrist band etc. And don't touch interface pin directly.

### 9-4. Precautions for Strong Light Exposure

Strong light exposure causes degradation of polarizer and color filter.

### 9-5. Storage

When storing modules as spares for a long time, the following precautions are necessary.

- (1) Store them in a dark place. Do not expose the module to sunlight or fluorescent light. Keep the temperature between 5°C and 35°C at normal humidity.
- (2) The polarizer surface should not come in contact with any other object.  
It is recommended that they be stored in the container in which they were shipped.

### 9-6. Handling Precautions for Protection Film

- (1) The protection film is attached to the bezel with a small masking tape.  
When the protection film is peeled off, static electricity is generated between the film and polarizer.  
This should be peeled off slowly and carefully by people who are electrically grounded and with well ion-blown equipment or in such a condition, etc.
- (2) When the module with protection film attached is stored for a long time, sometimes there remains a very small amount of glue still on the bezel after the protection film is peeled off.
- (3) You can remove the glue easily. When the glue remains on the bezel surface or its vestige is recognized, please wipe them off with absorbent cotton waste or other soft material like chamois soaked with normal-hexane.