

Product Specification

SPECIFICATION FOR APPROVAL

- () Preliminary Specification
 (●) Final Specification

Title	37.0" WXGA TFT LCD
-------	--------------------

BUYER	
MODEL	

SUPPLIER	LG.Philips LCD Co., Ltd.
*MODEL	LC370WX4
SUFFIX	SLA1(RoHs Verified)

*When you obtain standard approval,
 please use the above model name without suffix

APPROVED BY	SIGNATURE DATE
/	_____
/	_____
/	_____

Please return 1 copy for your confirmation with
 your signature and comments.

APPROVED BY	SIGNATURE DATE
J.H. Lee / Senior Manager	_____
REVIEWED BY	
J.K.Park / Manager	_____
PREPARED BY	
S.Y. Choi / Engineer	_____

TV Product Development Dept.
LG. Philips LCD Co., Ltd

Product Specification

Contents

Number	ITEM	Page
	COVER	1
	CONTENTS	2
	RECORD OF REVISIONS	3
1	GENERAL DESCRIPTION	4
2	ABSOLUTE MAXIMUM RATINGS	5
3	ELECTRICAL SPECIFICATIONS	6
3-1	ELECTRICAL CHARACTERISTICS	6
3-2	INTERFACE CONNECTIONS	8
3-3	SIGNAL TIMING SPECIFICATIONS	10
3-4	SIGNAL TIMING WAVEFORMS	11
3-5	COLOR INPUT DATA REFERENCE	12
3-6	POWER SEQUENCE	13
4	OPTICAL SPECIFICATIONS	15
5	MECHANICAL CHARACTERISTICS	19
6	RELIABILITY	22
7	INTERNATIONAL STANDARDS	23
7-1	SAFETY	23
7-2	EMC	23
8	PACKING	24
8-1	DESIGNATION OF LOT MARK	24
8-2	PACKING FORM	24
9	PRECAUTIONS	25
9-1	MOUNTING PRECAUTIONS	25
9-2	OPERATING PRECAUTIONS	25
9-3	ELECTROSTATIC DISCHARGE CONTROL	26
9-4	PRECAUTIONS FOR STRONG LIGHT EXPOSURE	26
9-5	STORAGE	26
9-6	HANDLING PRECAUTIONS FOR PROTECTION FILM	26

Product Specification

1. General Description

LC370WX1 is a Color Active Matrix Liquid Crystal Display with an integral External Electrode Fluorescent Lamp(EEFL) backlight system. The matrix employs a-Si Thin Film Transistor as the active element. It is a transmissive type display operating in the normally black mode. It has a 37.02 inch diagonally measured active display area with WXGA resolution (768 vertical by 1366 horizontal pixel array) Each pixel is divided into Red, Green and Blue sub-pixels or dots which are arranged in vertical stripes. Gray scale or the luminance of the sub-pixel color is determined with a 8-bit gray scale signal for each dot, thus presenting a palette of more than 16.7M(true) colors.

It has been designed to apply the 8-bit 1 port LVDS interface.

It is intended to support LCD TV, PCTV where high brightness, super wide viewing angle, high color gamut, high color depth and fast response time are important.

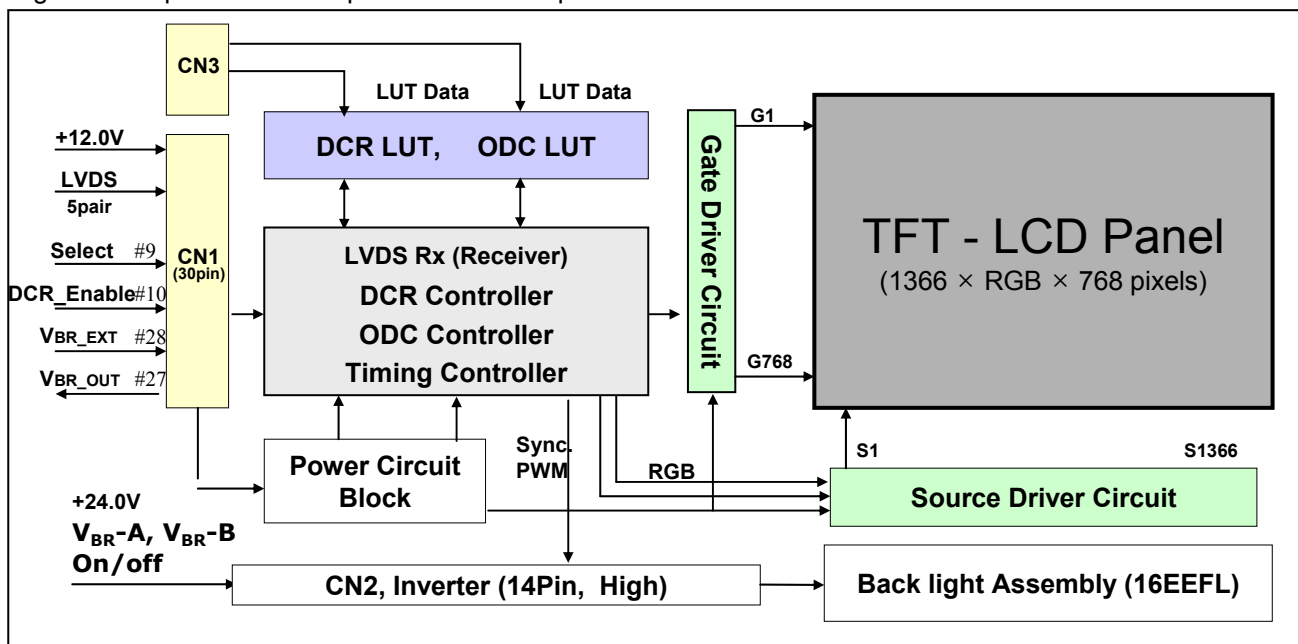

General Features

Active Screen Size	37.02 inches(940.3mm) diagonal
Outline Dimension	877.0mm(H) x 516.8mm(V) x 55.5mm(D) (Typ.)
Pixel Pitch	0.200mm x 0.600mm x RGB
Pixel Format	1366 horiz. by 768 vert. pixels RGB stripe arrangement
Color Depth	8-bit, 16.7 M colors
Luminance, White	500 cd/m ² (Center 1 point Typ.)
Viewing Angle (CR>10)	Viewing angle free (R/L 178(Typ.), U/D 178(Typ.))
Power Consumption	Total 124.8 Watt (Typ.) (Logic= 4.8 W, B/L= 120 W [VBR-A=1.65V])
Weight	9000 (Typ.)
Display Operating Mode	Transmissive mode, normally black
Surface Treatment	Hard coating(3H), Anti-glare treatment of the front polarizer (Haze 13%)

Product Specification

2. Absolute Maximum Ratings

The followings are maximum values which, if exceeded, may cause faulty operation or damage to the unit.

Table 1. ABSOLUTE MAXIMUM RATINGS

Parameter		Symbol	Value		Unit	Remark
			Min	Max		
Power Input Voltage	LCM	VLCD	+8.0	+14.0	VDC	at 25 ± 2 °C
	Backlight inverter	VBL	+21.6	+27.0	VDC	
ON/OFF Control Voltage		VON/OFF	-0.3	+5.5	VDC	
Brightness Control Voltage		VBR	0	+5.0	VDC	
Operating Temperature		TOP	0	+50	°C	Note 1,2
Storage Temperature		TST	-20	+60	°C	
Operating Ambient Humidity		HOP	10	90	%RH	
Storage Humidity		HST	10	90	%RH	

- Note : 1. Temperature and relative humidity range are shown in the figure below.
 Wet bulb temperature should be 39 °C Max. and no condensation of water.
 2. Gravity mura can be guaranteed under 40 °C condition.

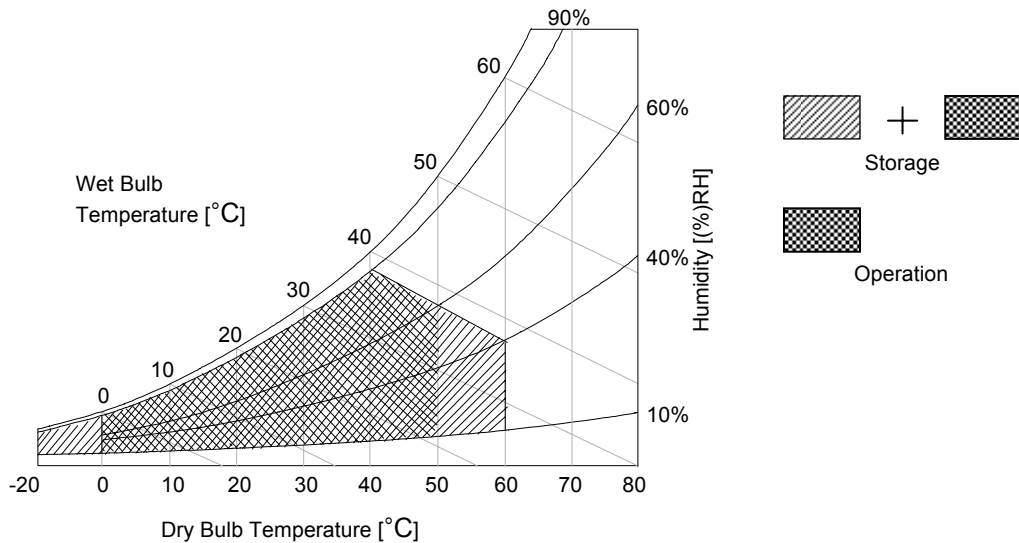

Product Specification

3. Electrical Specifications

3-1. Electrical Characteristics

It requires two power inputs. One is employed to power the LCD electronics and to drive the TFT array and liquid crystal. The other input power for the EEFL/Backlight is to power inverter.

Table 2. ELECTRICAL CHARACTERISTICS

Parameter	Symbol	Value			Unit	Note
		Min	Typ	Max		
MODULE :						
Power Input Voltage	V _{LCD}	11.4	12.0	12.6	V _{DC}	
Power Input Current	I _{LCD}	-	400	500	mA	1
		-	535	785	mA	2
Power Consumption	P _{LCD}	-	4.4	5.2	Watt	1
Rush current	I _{RUSH}	-	-	3.5	A	3

Note :

1. The specified current and power consumption are under the $V_{LCD}=12.0V$, $25 \pm 2^{\circ}C$, $f_V=60Hz$ condition whereas mosaic pattern(8 x 6) is displayed and f_V is the frame frequency.
2. The current is specified at the maximum current pattern.
3. The duration of rush current is about 2ms and rising time of power Input is 1ms(min.).

White : 255Gray
Black : 0Gray

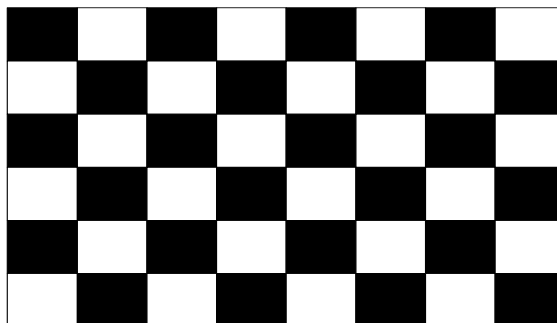

Mosaic Pattern(8 x 6)

Product Specification

Table 3. ELECTRICAL CHARACTERISTICS (Continue)

Parameter		Symbol	Values			Unit	Notes	
			Min	Typ	Max			
Inverter :								
Power Supply Input Voltage		VBL	22.8	24.0	25.2	Vdc	1	
Power Supply Input Voltage Ripple			-	-	0.5	Vp-p	1	
Power Supply Input Current	After Aging	IBL_A	-	5	5.3	A	$V_{BR-A} = 1.65V \dots 1$	
			-	5.5	5.8	A	$V_{BR-A} = 3.3V \dots 1$	
	Before Aging	IBL_B	-	5.5	5.8	A	$V_{BR-A} = 1.65V \dots 2$	
			-	6	6.3	A	$V_{BR-A} = 3.3V \dots 2$	
Power Supply Input Current (In-Rush)		Irush	-	-	8	A	$V_{BL} = 22.8V$ $V_{BR-B} = 3.3V$ $V_{BR-A} = 1.65V$	
Power Consumption		PBL	-			W	$V_{BR-A} = 1.65V \dots 1$	
Input Voltage for Control System Signals	Brightness Adjust		V_{BR-A}	0.0	1.65	3.3	Vdc	
	On/Off	On	V on	2.5	-	5.0	Vdc	
		Off	V off	-0.3	0.0	0.8	Vdc	
	Brightness Adjust		V_{BR-B}	0	-	3.3	V	3
Lamp:								
Discharge Stabilization Time		Ts			3	min	4	
Life Time			50,000			Hrs	5	

Notes :

- Electrical characteristics are determined after the unit has been 'ON' and stable for approximately 120 minutes at $25 \pm 2^\circ\text{C}$. The specified current and power consumption are under the typical supply Input voltage 24V and V_{BR} ($V_{BR-A} : 1.65V$ & $V_{BR-B} : 3.3V$), it is total power consumption. The ripple voltage of the power supply input voltage is under 0.5 Vp-p. LPL recommend Input Voltage is $24.0V \pm 5\%$.
- Electrical characteristics are determined within 30 minutes at $25 \pm 2^\circ\text{C}$. The specified currents are under the typical supply Input voltage 24V.
- Brightness Control.
This V_{BR-B} Voltage control brightness.

V_{BR-B} Voltage	Function	V_{BR-B} Voltage	Function
0V	Minimum Duty (20%)	3.3V	Maximum Duty (100%)

- The brightness of the lamp after lighted for 5minutes is defined as 100%.
 T_s is the time required for the brightness of the center of the lamp to be not less than 95% at typical current. The screen of LCD module may be partially dark by the time the brightness of lamp is stable after turn on.
- Specified Values are for a single lamp which is aligned horizontally.
The life time is determined as the time which luminance of the lamp is 50% compared to that of initial value at the typical lamp current ($V_{BR-A} : 1.65V$ & $V_{BR-B} : 3.3V$), on condition of continuous operating at $25 \pm 2^\circ\text{C}$
- The duration of rush current is about 10ms.

Product Specification

3-2. Interface Connections

This LCD employs two kinds of interface connection, a 30-pin connector is used for the module electronics, 14 Connectors are used for the integral backlight system.

3-2-1. LCD Module

- LCD Connector(CN1) : FI-X30SSL-HF (Manufactured by JAE) or Equivalent
- Mating Connector : FI-X30C2L (Manufactured by JAE) or Equivalent

Table 4. MODULE CONNECTOR(CN1) PIN CONFIGURATION

Pin No.	Symbol	Description	Note
1	VLCD	Power Supply +12.0V	
2	VLCD	Power Supply +12.0V	
3	VLCD	Power Supply +12.0V	
4	VLCD	Power Supply +12.0V	
5	GND	Ground	
6	GND	Ground	
7	GND	Ground	
8	GND	Ground	
9	Select	Select LVDS Data format	1
10	DCR Enable	Dynamic CR Enable ('L' = Disable , 'H' = Enable)	2
11	GND	Ground	
12	RA-	LVDS Receiver Signal(-)	
13	RA+	LVDS Receiver Signal(+)	
14	GND	Ground	
15	RB-	LVDS Receiver Signal(-)	
16	RB+	LVDS Receiver Signal(+)	
17	GND	Ground	
18	RC-	LVDS Receiver Signal(-)	
19	RC+	LVDS Receiver Signal(+)	
20	GND	Ground	
21	RCLK-	LVDS Receiver Clock Signal(-)	
22	RCLK+	LVDS Receiver Clock Signal(+)	
23	GND	Ground	
24	RD-	LVDS Receiver Signal(-)	
25	RD+	LVDS Receiver Signal(+)	
26	GND	Ground	
27	VBR_OUT	VBR output form LCD module	
28	VBR_EXT	External VBR input from System to LCD module	
29	GND	Ground	
30	GND	Ground	3

Note: 1. If the pin no. 9 is Ground, Interface format is "LG", and if the pin no. 9 is Vcc(3.3V), Interface format is "DISM". See page 9 and 10.

2. When this pin is no connection or Ground, DCR is Disabled.

3. The pin no. 30 is necessary for LCD test.

When LVDS signals are abnormal operation more than 3-Vsync times and power 12V is supplied,

'Open' or 'Vcc' : LCD operate itself some test patterns.(AGP – Auto Generation Pattern)

'Ground' : LCD operate itself a black pattern. (NSB – No Signal Black)

LPL recommend 'Ground' for NSB.

4. All GND (ground) pins should be connected together, which should be also connected to the LCD module's metal frame.

5. All VLCD (power input) pins should be connected together.

6. Input Levels of LVDS signals are based on the IEA 664 Standard.

Product Specification

3-2-2. Backlight Inverter

Inverter Connector : S14B-PH-SMC

(manufactured by YeonHo) or Equivalent

- Mating Connector : PHR-14 or Equivalent

Table 5. INVERTER CONNECTOR PIN CONFIGURATION

Pin No	Symbol	Description	Inv.	Note
1	VBL	Power Supply +24.0V	VBL	
2	VBL	Power Supply +24.0V	VBL	
3	VBL	Power Supply +24.0V	VBL	
4	VBL	Power Supply +24.0V	VBL	
5	VBL	Power Supply +24.0V	VBL	
6	GND	Backlight Ground	GND	1
7	GND	Backlight Ground	GND	
8	GND	Backlight Ground	GND	
9	GND	Backlight Ground	GND	
10	GND	Backlight Ground	GND	
11	VBR-A	Analog dimming voltage DC 0.0V ~ 3.3V (Typ : 1.65V)	VBR-A	2, 3
12	VON/OFF	0.0V ~ 5.0V	On/Off	
13	VBR-B	Burst dimming voltage DC 0.0V ~ 3.3V	VBR-B	3
14	Status	Normal : Upper 3.0V Abnormal : Under 0.7V	Status	4

Notes : 1. GND should be connected to the LCD module's metal frame.

2. If Pin #11 is open, VBR-A = 1.65V. When apply over 1.65V (~ 3.3V) continuously, its luminance is increasing however lamp's life time is decreasing.

It could be usable for boost up luminance when using DCR (=Dynamic contrast ratio) function only.

3. Minimum Brightness : VBR-B = 0V Maximum Brightness : VBR-B = 3.3V

4. Even though Pin #14 is open, there is no effect on inverter operating. The output terminal of inverter.

5. Each impedance of pin #11,12 and 13 is 200[KΩ], 100[KΩ], 100[KΩ]

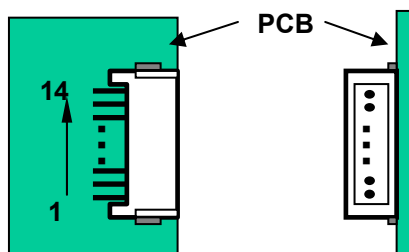
◆ Rear view of LCM

Product Specification

3-3. Signal Timing Specifications

Table 6 and Table 7 show the signal timing required at the input of the LVDS transmitter. All of the interface signal timings should be satisfied with the following specification for normal operation.

Table 6. TIMING TABLE for NTSC

Item	Symbol	Min.	Typ.	Max.	Unit	Notes	
DCLK Period	t_{CLK}	12.5	13.8	15.8	nsec		
DCLK Frequency	f_{CLK}	63.0	72.4	80.0	MHz		
Vertical	Frequency	f_V	57	60	63	Hz	
	Valid	t_{VV}	-	768	-	Line	
	Blank	$t_{VT} - t_{VV}$	8	22	295	Line	
	Total	t_{VT}	776	790	1063	Line	
Horizontal	Frequency	f_H	45	47.4	50	KHz	
	Valid	t_{HV}	-	1366	-	t_{CLK}	
	Blank	$t_{HT} - t_{HV}$	90	162	410	t_{CLK}	
	Total	t_{HT}	1456	1528	1776	t_{CLK}	

Table 7. TIMING TABLE for PAL

Item	Symbol	Min.	Typ.	Max.	Unit	Notes	
DCLK Period	t_{CLK}	12.5	13.8	15.8	nsec		
DCLK Frequency	f_{CLK}	63.0	72.4	80.0	MHz		
Vertical	Frequency	f_V	47	50	53	Hz	
	Valid	t_{VV}	-	768	-	Line	
	Blank	$t_{VT} - t_{VV}$	8	180	295	Line	
	Total	t_{VT}	776	948	1063	Line	
Horizontal	Frequency	f_H	45	47.4	50	KHz	
	Valid	t_{HV}	-	1366	-	t_{CLK}	
	Blank	$t_{HT} - t_{HV}$	90	162	410	t_{CLK}	
	Total	t_{HT}	1456	1528	1776	t_{CLK}	

Note :

1. The performance of the electro-optical characteristics may be influenced by variance of the vertical refresh rate.
2. Above Timing Tables are only valid for DE Mode.

Product Specification

3-4. Signal Timing Waveforms

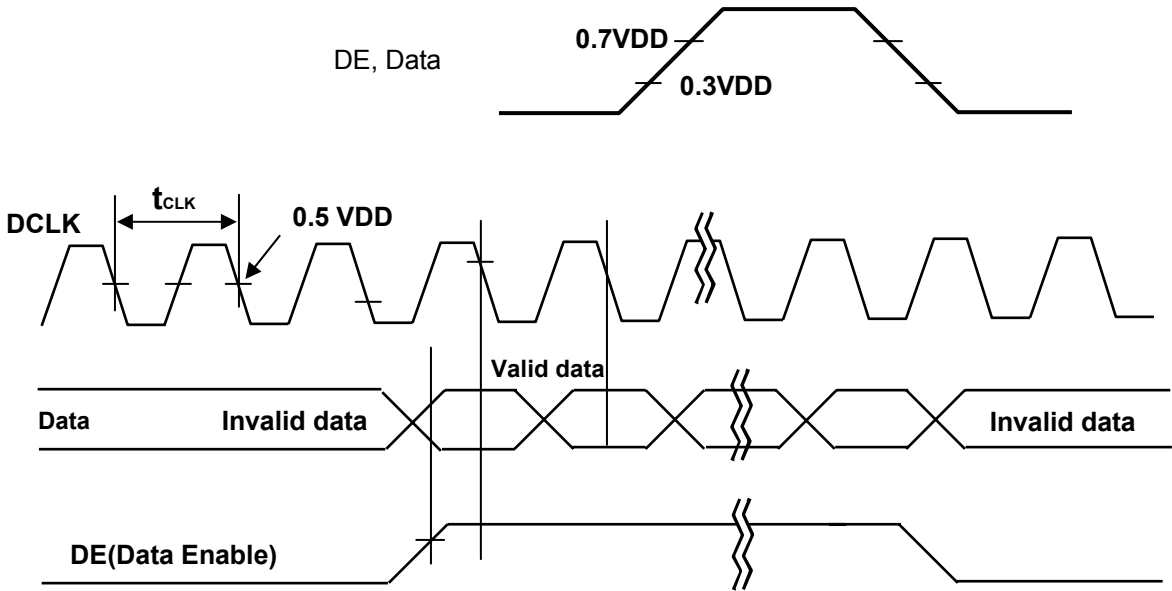

* Reference : Sync. Relation

* $t_{HB} = t_{HFP} + t_{WH} + t_{HBP}$

* $t_{VB} = t_{VFP} + t_{VW} + t_{VBP}$

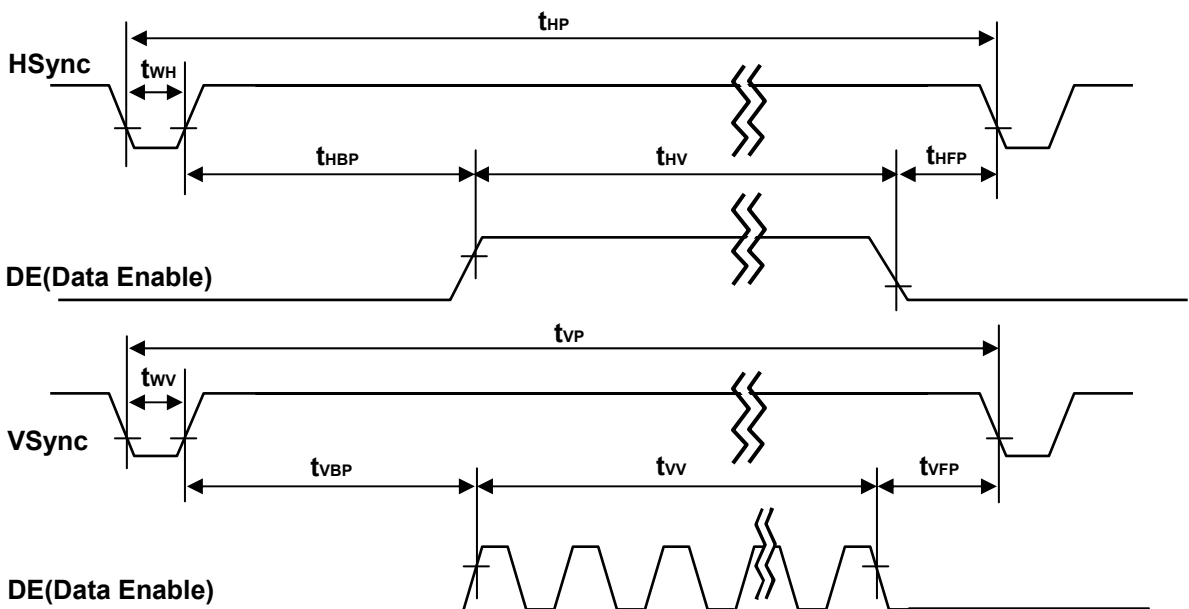

Product Specification

3-5. Color Data Reference

The brightness of each primary color(red,green,blue) is based on the 8-bit gray scale data input for the color the higher the binary input, the brighter the color. The table below provides a reference for color versus data input.

Table 8. COLOR DATA REFERENCE

Color		Input Color Data																							
		RED								GREEN								BLUE							
		MSB	LSB						MSB	LSB						MSB	LSB								
		R7	R6	R5	R4	R3	R2	R1	R0	G7	G6	G5	G4	G3	G2	G1	G0	B7	B6	B5	B4	B3	B2	B1	B0
Basic Color	Black	0	0	0	0	0	0	0	0	0	0	0	0	0	0	0	0	0	0	0	0	0	0	0	0
	Red (255)	1	1	1	1	1	1	1	1	0	0	0	0	0	0	0	0	0	0	0	0	0	0	0	0
	Green (255)	0	0	0	0	0	0	0	0	1	1	1	1	1	1	1	1	0	0	0	0	0	0	0	0
	Blue (255)	0	0	0	0	0	0	0	0	0	0	0	0	0	0	0	0	1	1	1	1	1	1	1	1
	Cyan	0	0	0	0	0	0	0	0	1	1	1	1	1	1	1	1	1	1	1	1	1	1	1	1
	Magenta	1	1	1	1	1	1	1	1	0	0	0	0	0	0	0	0	1	1	1	1	1	1	1	1
	Yellow	1	1	1	1	1	1	1	1	1	1	1	1	1	1	1	1	0	0	0	0	0	0	0	0
	White	1	1	1	1	1	1	1	1	1	1	1	1	1	1	1	1	1	1	1	1	1	1	1	1
RED	RED (000) Dark	0	0	0	0	0	0	0	0	0	0	0	0	0	0	0	0	0	0	0	0	0	0	0	0
	RED (001)	0	0	0	0	0	0	0	1	0	0	0	0	0	0	0	0	0	0	0	0	0	0	0	0
							
	RED (254)	1	1	1	1	1	1	1	0	0	0	0	0	0	0	0	0	0	0	0	0	0	0	0	0
	RED (255)	1	1	1	1	1	1	1	1	0	0	0	0	0	0	0	0	0	0	0	0	0	0	0	0
GREEN	GREEN (000) Dark	0	0	0	0	0	0	0	0	0	0	0	0	0	0	0	0	0	0	0	0	0	0	0	0
	GREEN (001)	0	0	0	0	0	0	0	0	0	0	0	0	0	0	0	1	0	0	0	0	0	0	0	0
							
	GREEN (254)	0	0	0	0	0	0	0	0	1	1	1	1	1	1	1	0	0	0	0	0	0	0	0	0
	GREEN (255)	0	0	0	0	0	0	0	0	1	1	1	1	1	1	1	1	0	0	0	0	0	0	0	0
BLUE	BLUE (000) Dark	0	0	0	0	0	0	0	0	0	0	0	0	0	0	0	0	0	0	0	0	0	0	0	0
	BLUE (001)	0	0	0	0	0	0	0	0	0	0	0	0	0	0	0	0	0	0	0	0	0	0	0	1
							
	BLUE (254)	0	0	0	0	0	0	0	0	0	0	0	0	0	0	0	0	1	1	1	1	1	1	1	0
	BLUE (255)	0	0	0	0	0	0	0	0	0	0	0	0	0	0	0	0	1	1	1	1	1	1	1	1

Product Specification

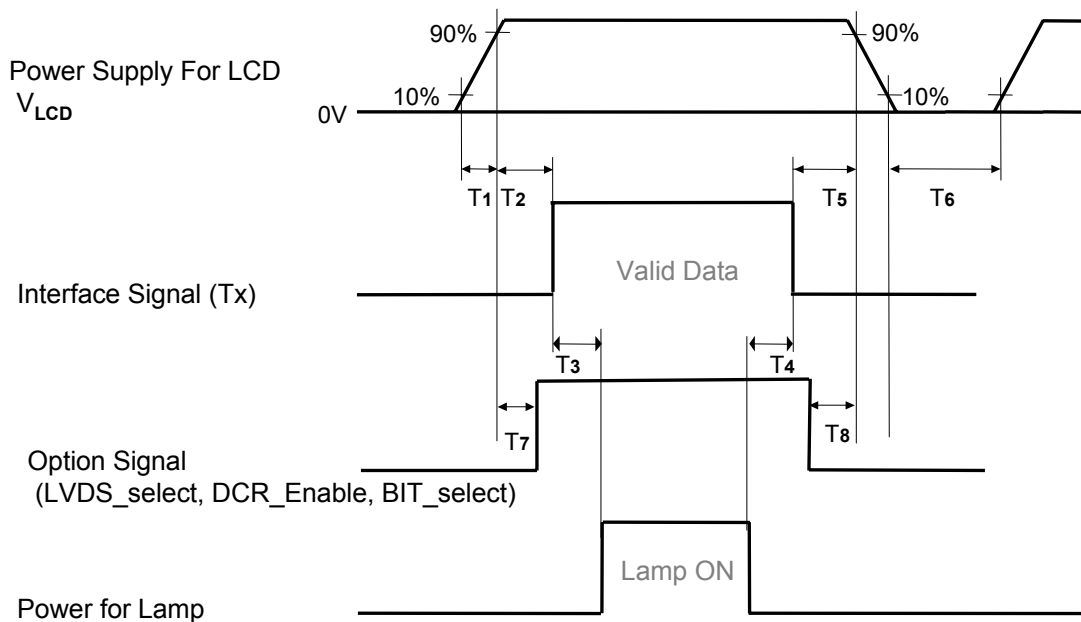
3-6. Power Sequence**3-6-1. LCD Driving circuit****Table 9. POWER SEQUENCE**

Parameter	Value			Unit	Notes
	Min	Typ	Max		
T1	0.5	-	20	ms	
T2	0.5	-	$3 \times (1/f_V)$	ms	3,5
T3	200	-	-	ms	4
T4	200	-	-	ms	4
T5	0	-	-	ms	3,5
T6	2.0	-	-	s	2,6
T7	0	-	T2	ms	5
T8	0	-	-	ms	5

- Note :
1. Please avoid floating state of interface signal at invalid period.
 2. When the interface signal is invalid, be sure to pull down the power supply V_{LCD} to 0V.
 3. The case when the T2/T5 exceed $3 \times (1/f_V)$, it operates protection pattern (Black pattern) till valid signal inputted. There is no reliability problem. (ex. 60Hz : $3 \times (1/60\text{Hz}) = 50\text{ms}$)
 4. The T3/T4 is recommended value, the case when failed to meet a minimum specification, abnormal display would be shown. There is no reliability problem.
 5. If the on time of signals (Interface signal and Option signals) precedes the on time of Power (V_{LCD}), check the LCD logic Power (V_{CC}) is under 0.8V, otherwise it will be happened abnormal display.
 6. T6 should be measured after the Module has been fully discharged between power off and on period.

Product Specification

3-6-2. Sequence for Inverter

Power Supply For Inverter

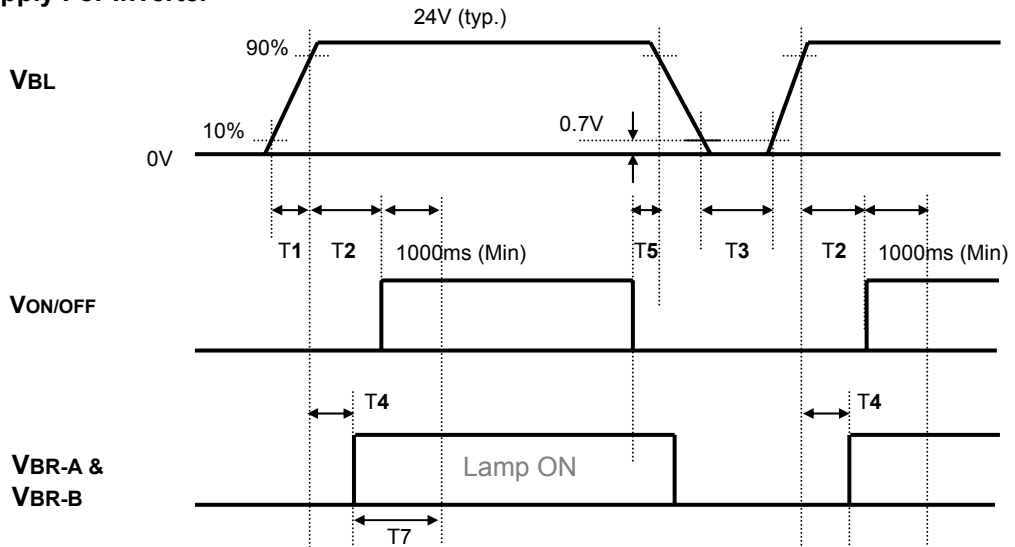

3-6-3. Deep condition for Inverter

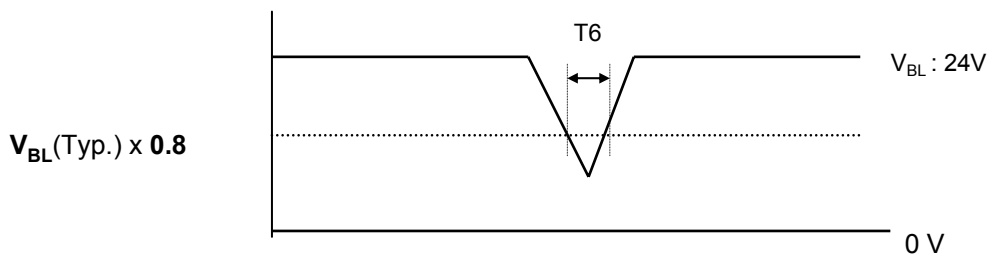

Table 10. Power Sequence for Inverter

Parameter	Values			Units	Remarks
	Min	Typ	Max		
T1	20	-	-	ms	1
T2	500	-	-	ms	
T3	200	-	-	ms	
T4	0	-	-	ms	2
T5	10	-	-	ms	
T6	-	-	10	ms	$V_{BL}(Typ) \times 0.8$
T7	1000	-	-	ms	3

- Notes : 1. T1 describes rising time of 0V to 24V and this parameter does not applied at restarting time.
 2. T4(max) is less than T2.
 3. In T7 section, VBR-B is recommended 3.3V.

Product Specification

4. Optical Specification

Optical characteristics are determined after the unit has been 'ON' for 30min in a dark environment at $25 \pm 2^\circ\text{C}$. The values specified are at an approximate distance 50cm from the LCD surface at a viewing angle of Φ and θ equal to 0° .

It is presented additional information concerning the measurement equipment and method in FIG. 1.

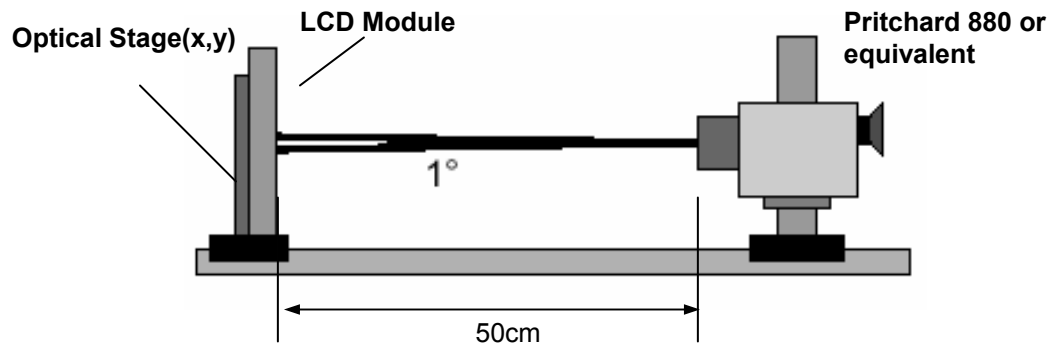

FIG. 1 Optical Characteristic Measurement Equipment and Method

Table 11. OPTICAL CHARACTERISTICS

$T_a = 25 \pm 2^\circ\text{C}$, $V_{\text{LCD}} = 12.0\text{V}$, $f_v = 60\text{Hz}$, $D_{\text{clk}} = 72\text{MHz}$,
 $V_{\text{BR}_A} = 1.65\text{V}$, $V_{\text{BR}_B} = 3.3\text{V}$, Except DCR Function

Parameter	Symbol	Value			Unit	Note	
		Min	Typ	Max			
Contrast Ratio	CR	800	1000			1	
	DCR	-	-			Appendix 6	
Surface Luminance, white	L_{WH}	400	500		cd/m^2	2	
Luminance Variation	δ_{WHITE} 5P			1.3		3	
Response Time	G to G	-	6	10	ms	4	
Color Coordinates [CIE1931]	RED	Rx	Typ -0.03	0.636	Typ +0.03		
		Ry		0.343			
	GREEN	Gx		0.284			
		Gy		0.615			
	BLUE	Bx		0.144			
		By		0.063			
	WHITE	Wx		0.279			
		Wy		0.292			
Viewing Angle (CR>10)							
	x axis, right($\phi=0^\circ$)	θ_r	89	-	-	degree	5
	x axis, left ($\phi=180^\circ$)	θ_l	89	-	-		
	y axis, up ($\phi=90^\circ$)	θ_u	89	-	-		
	y axis, down ($\phi=270^\circ$)	θ_d	89	-	-		
Gray Scale						6	

Product Specification

Notes 1. Contrast Ratio(CR) is defined mathematically as :

CR (Contrast Ratio) = Maximum CR_n (n=1, 2, 3, 4, 5)
DCR (Dynamic CR) = Maximum CR_n (n=1, 2, 3, 4, 5)

$$CR_n = \frac{\text{Surface Luminance at position n with all white pixels}}{\text{Surface Luminance at position n with all black pixels}}$$

n = the Position number(1, 2, 3, 4, 5), For more information, see FIG 2.

2. Surface luminance is luminance value at the center point across the LCD surface 50cm from the surface with all pixels displaying white.
For more information, see FIG 2.
3. The variation in surface luminance , δ WHITE is defined as :
 δ WHITE(5P) = Maximum($L_{on1}, L_{on2}, L_{on3}, \dots, L_{on5}$) / Minimum($L_{on1}, L_{on2}, L_{on3}, \dots, L_{on5}$)
Where L_{on1} to L_{on5} are the luminance with all pixels displaying white at 5 locations .
For more information, see FIG 2.
4. Response time is the time required for the display to transition from G(N) to G(M) (Rise Time, Tr_R) and from G(M) to G(N) (Decay Time, Tr_D). For additional information see the FIG. 3. (N<M)
5. Viewing angle is the angle at which the contrast ratio is greater than 10. The angles are determined for the horizontal or x axis and the vertical or y axis with respect to the z axis which is normal to the LCD surface. For more information, see FIG 4.
6. Gray scale specification
Gamma Value is approximately 2.2. For more information, see Table 12.

Table 12. GRAY SCALE SPECIFICATION

Gray Level	Luminance [%] (Typ)
L0	0.10
L15	0.32
L31	1.10
L47	2.60
L63	4.90
L79	8.10
L95	12.1
L111	16.7
L127	21.6
L143	28.0
L159	35.4
L175	43.9
L191	53.3
L207	64.1
L223	75.8
L239	88.0
L255	100

Product Specification

Measuring point for surface luminance & measuring point for luminance variation

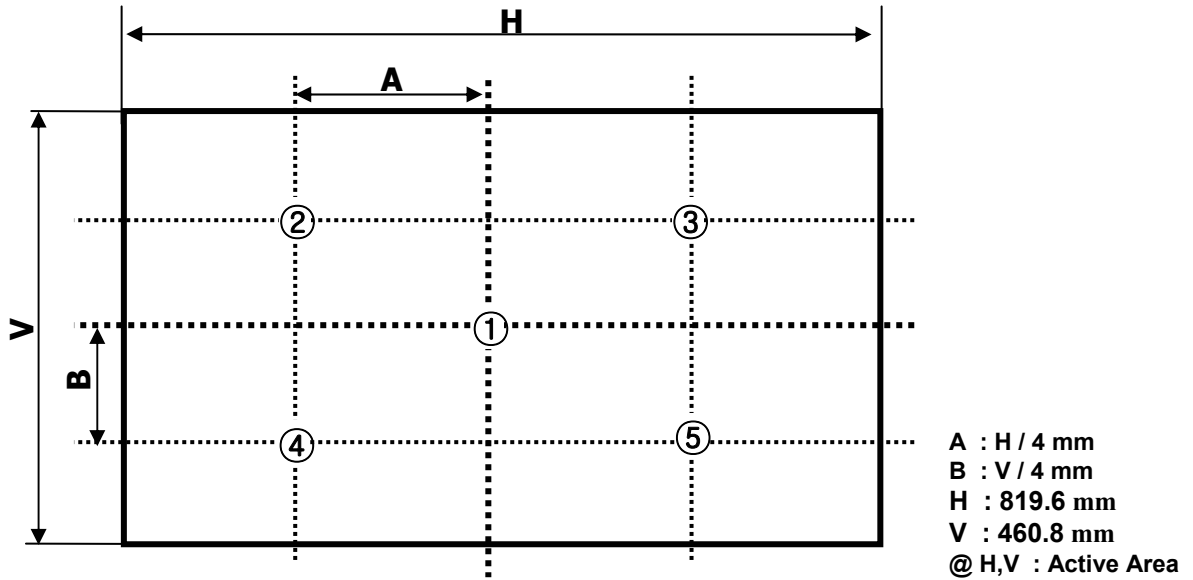

FIG. 2 Measure Point for Luminance

Response time is defined as the following figure and shall be measured by switching the input signal for “Gray(N)” and “Gray(M)”.

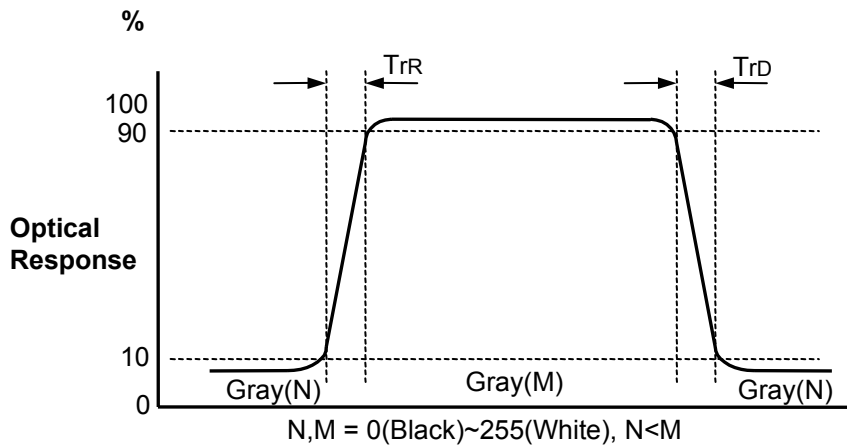

FIG. 3 Response Time

Product Specification

Dimension of viewing angle range

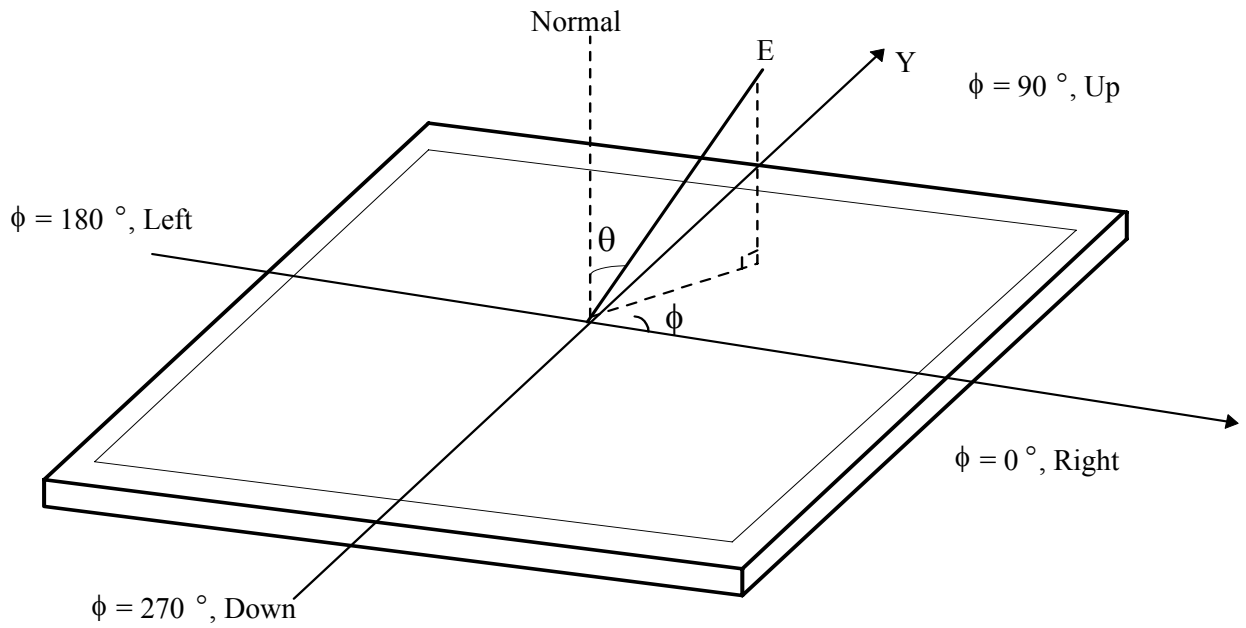

FIG. 4 Viewing angle

Product Specification

5. Mechanical Characteristics

The following items provide general mechanical characteristics. In addition the figures in the next page are detailed mechanical drawing of the LCD module.

Table 13. MECHANICAL CHARACTERISTICS

Outline Dimension	Horizontal	877.0 mm
	Vertical	516.8 mm
	Depth	55.5 mm
Bezel Area	Horizontal	828.6mm
	Vertical	469.8mm
Active Display Area	Horizontal	819.6mm
	Vertical	460.8mm
Weight	9000(Typ.)/9500(Max)	
Surface Treatment	Hard coating(3H) Anti-glare treatment of the front polarizer, Haze 13%	

Note : Please refer to a mechanic drawing in terms of tolerance at the next page.

Product Specification

<FRONT VIEW>

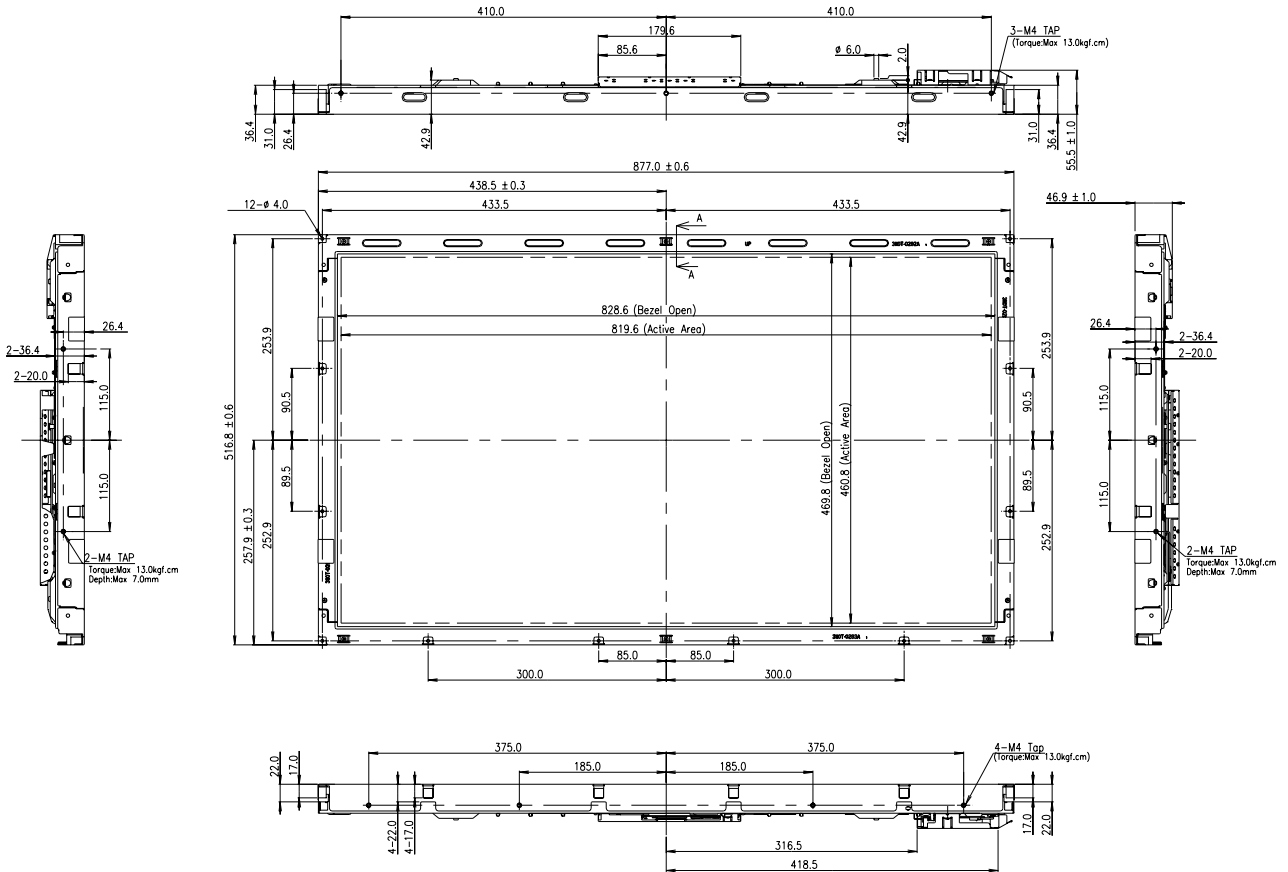

SECTION A-A
SCALE 1/1

Product Specification

<REAR VIEW>

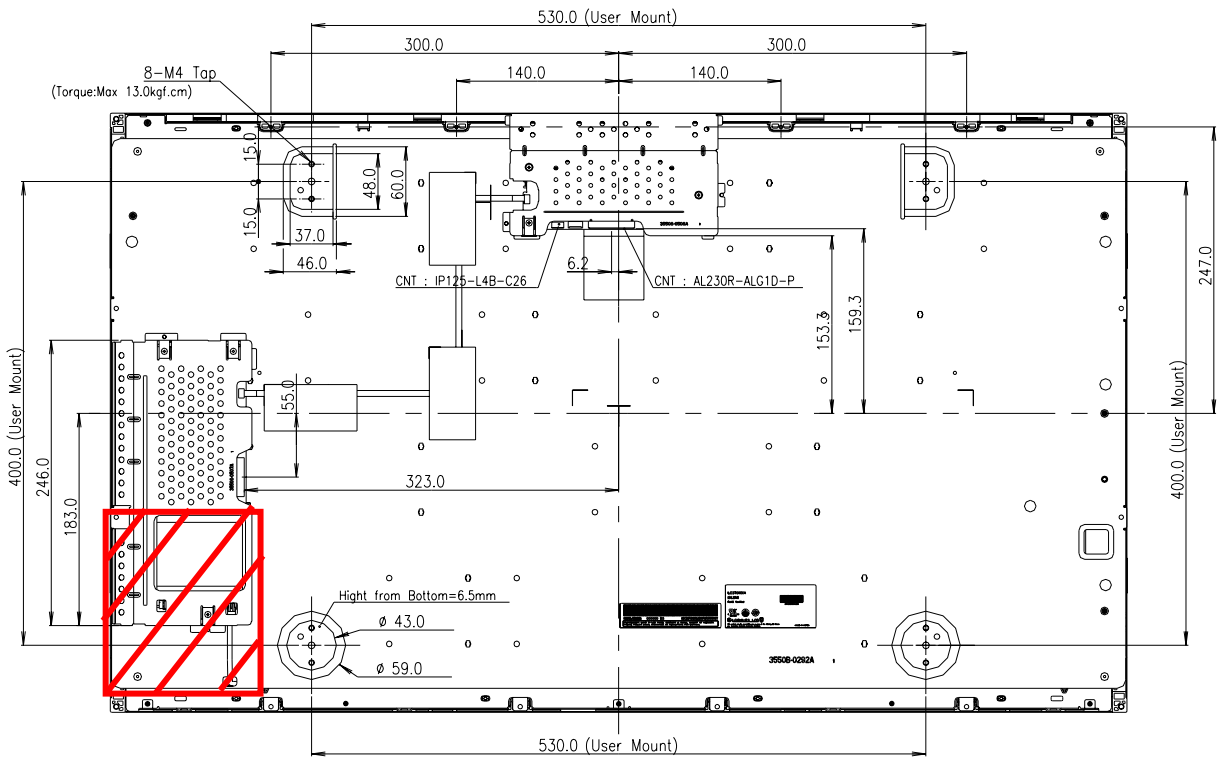

NOTES

1. Unspecified tolerances are to be $\pm 0.5\text{mm}$.
2. This drawing is only preliminary data and can be changed without notice.
3. Tilt and partial disposition tolerance of display area is as following.
 - (1) X-Direction : IA-BI $\leq 1.5\text{mm}$
 - (2) Y-Direction : IC-DI $\leq 1.5\text{mm}$

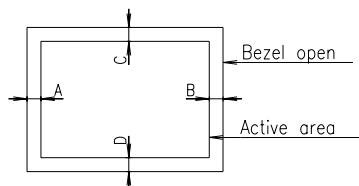

Notes : It should be recommended that any exterior materials do not go passing up the red area slanted. (For example, electrical cable, system board , etc). Otherwise, it could cause that abnormal display happens.

Product Specification

6. Reliability

Table 14. ENVIRONMENT TEST CONDITION

No.	Test Item	Condition
1	High temperature storage test	Ta= 50°C 240h
2	Low temperature storage test	Ta= -20°C 240h
3	High temperature operation test	Ta= 40°C 50%RH 240h
4	Low temperature operation test	Ta= 0°C 240h
5	Vibration test (non-operating)	Wave form : random Vibration level : 1.0G RMS Bandwidth : 10-500Hz Duration : X,Y,Z, 10 min One time each direction
6	Shock test (non-operating)	Shock level : 100G Waveform : half sine wave, 2ms Direction : ±X, ±Y, ±Z One time each direction
7	Humidity condition Operation	Ta= 40 °C, 90%RH

Product Specification

7. International Standards

7-1. Safety

- a) UL 60065, 7th Edition, dated June 30, 2003, Underwriters Laboratories, Inc., Standard for Audio, Video and Similar Electronic Apparatus.
- b) CAN/CSA C22.2, No. 60065:03, Canadian Standards Association, Standard for Audio, Video and Similar Electronic Apparatus.
- c) IEC60065:2001, 7th Edition CB-scheme and EN 60065:2002, Safety requirements for Audio, Video and Similar Electronic Apparatus..

7-2. EMC

- a) ANSI C63.4 "Methods of Measurement of Radio-Noise Emissions from Low-Voltage Electrical and Electrical Equipment in the Range of 9kHz to 40GHz. "American National Standards Institute(ANSI), 1992
- b) CISPR13 "Limits and Methods of Measurement of Radio interference characteristics of Sound and Television broadcast receivers and associated equipment"
CISPR22 "Limits and Methods of Measurement of Radio interference characteristics of Information Technology Equipment" International Special Committee on Radio Interference.
- c) EN55013 "Limits and Methods of Measurement of Radio interference characteristics of Sound and Television broadcast receivers and associated equipment"
EN55022 "Limits and Methods of Measurement of Radio interference characteristics of Information Technology Equipment" European Committee for Electro Technical Standardization.(CENELEC), 1988(Including A1:2000)

Product Specification

8. Packing**8-1. Designation of Lot Mark**

a) Lot Mark

A	B	C	D	E	F	G	H	I	J	K	L	M
---	---	---	---	---	---	---	---	---	---	---	---	---

A,B,C : SIZE(INCH)

E : MONTH

D : YEAR

F ~ M : SERIAL NO.

Note

1. YEAR

Year	2001	2002	2003	2004	2005	2006	2007	2008	2009	2010
Mark	1	2	3	4	5	6	7	8	9	0

2. MONTH

Month	Jan	Feb	Mar	Apr	May	Jun	Jul	Aug	Sep	Oct	Nov	Dec
Mark	1	2	3	4	5	6	7	8	9	A	B	C

b) Location of Lot Mark

Serial No. is printed on the label. The label is attached to the backside of the LCD module.
This is subject to change without prior notice.

8-2. Packing Form

a) Package quantity in one box : 4 pcs

b) Box Size : 968mm X 366mm X 595mm

Product Specification

9. Precautions

Please pay attention to the followings when you use this TFT LCD module.

9-1. Mounting Precautions

- (1) You must mount a module using specified mounting holes (Details refer to the drawings).
- (2) You should consider the mounting structure so that uneven force (ex. Twisted stress) is not applied to the module. And the case on which a module is mounted should have sufficient strength so that external force is not transmitted directly to the module.
- (3) Please attach the surface transparent protective plate to the surface in order to protect the polarizer. Transparent protective plate should have sufficient strength in order to resist external force.
- (4) You should adopt radiation structure to satisfy the temperature specification.
- (5) Acetic acid type and chlorine type materials for the cover case are not desirable because the former generates corrosive gas of attacking the polarizer at high temperature and the latter causes circuit break by electro-chemical reaction.
- (6) Do not touch, push or rub the exposed polarizers with glass, tweezers or anything harder than HB pencil lead. And please do not rub with dust clothes with chemical treatment. Do not touch the surface of polarizer for bare hand or greasy cloth.(Some cosmetics are detrimental to the polarizer.)
- (7) When the surface becomes dusty, please wipe gently with absorbent cotton or other soft materials like chamois soaks with petroleum benzene. Normal-hexane is recommended for cleaning the adhesives used to attach front / rear polarizers. Do not use acetone, toluene and alcohol because they cause chemical damage to the polarizer.
- (8) Wipe off saliva or water drops as soon as possible. Their long time contact with polarizer causes deformations and color fading.
- (9) Do not open the case because inside circuits do not have sufficient strength.

9-2. Operating Precautions

- (1) The spike noise causes the mis-operation of circuits. It should be lower than following voltage :
 $V = \pm 200\text{mV}$ (Over and under shoot voltage)
- (2) Response time depends on the temperature.(In lower temperature, it becomes longer.)
- (3) Brightness depends on the temperature. (In lower temperature, it becomes lower.)
And in lower temperature, response time(required time that brightness is stable after turned on) becomes longer
- (4) Be careful for condensation at sudden temperature change. Condensation makes damage to polarizer or electrical contacted parts. And after fading condensation, smear or spot will occur.
- (5) When fixed patterns are displayed for a long time, remnant image is likely to occur.
- (6) Module has high frequency circuits. Sufficient suppression to the electromagnetic interference shall be done by system manufacturers. Grounding and shielding methods may be important to minimize the interference.
- (7) Please do not give any mechanical and/or acoustical impact to LCM. Otherwise, LCM can't be operated its full characteristics perfectly.
- (8) A screw which is fastened up the steels should be a machine screw.
(if not, it can cause conductive particles and deal LCM a fatal blow)
- (9) Please do not set LCD on its edge.
- (10) It is recommended to avoid the signal cable and conductive material over the inverter transformer for it can cause the abnormal display and temperature rising.

Product Specification

9-3. Electrostatic Discharge Control

Since a module is composed of electronic circuits, it is not strong to electrostatic discharge. Make certain that treatment persons are connected to ground through wrist band etc. And don't touch interface pin directly.

9-4. Precautions for Strong Light Exposure

Strong light exposure causes degradation of polarizer and color filter.

9-5. Storage

When storing modules as spares for a long time, the following precautions are necessary.

- (1) Store them in a dark place. Do not expose the module to sunlight or fluorescent light. Keep the temperature between 5°C and 35°C at normal humidity.
- (2) The polarizer surface should not come in contact with any other object.
It is recommended that they be stored in the container in which they were shipped.

9-6. Handling Precautions for Protection Film

- (1) The protection film is attached to the bezel with a small masking tape.
When the protection film is peeled off, static electricity is generated between the film and polarizer.
This should be peeled off slowly and carefully by people who are electrically grounded and with well ion-blown equipment or in such a condition, etc.
- (2) When the module with protection film attached is stored for a long time, sometimes there remains a very small amount of glue still on the bezel after the protection film is peeled off.
- (3) You can remove the glue easily. When the glue remains on the bezel surface or its vestige is recognized, please wipe them off with absorbent cotton waste or other soft material like chamois soaked with normal-hexane.

Product Specification

Appendix 1-1.

■ REQUIRED SIGNAL ASSIGNMENT FOR LVDS TRANSMITTER (Pin9="L")

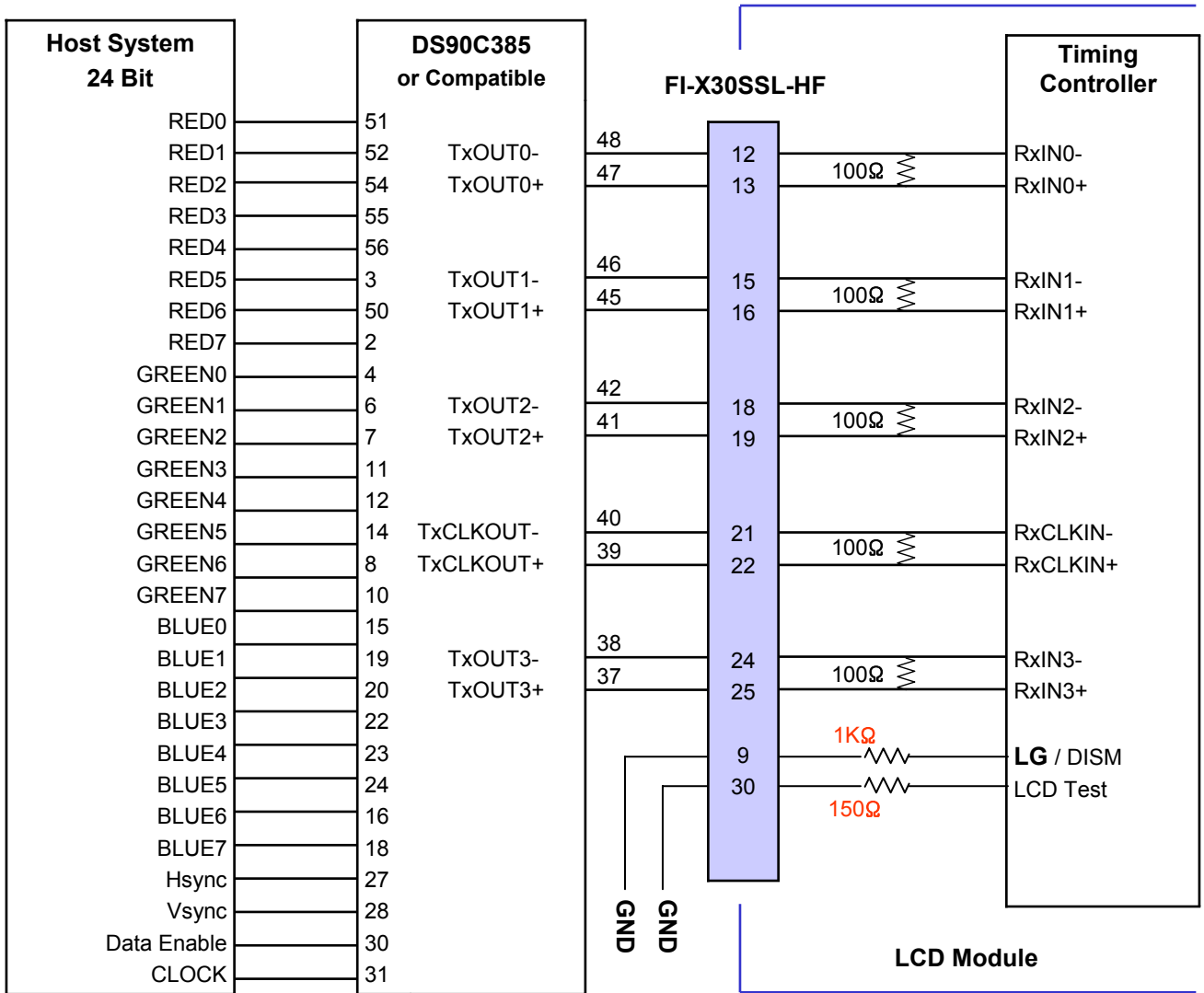

- Note: 1. The LCD Module uses a 100 Ohm[Ω] resistor between positive and negative lines of each receiver input.
 2. Refer to LVDS Transmitter Data Sheet for detail descriptions. (DS90C385 or Compatible)
 3. '7' means MSB and '0' means LSB at R,G,B pixel data.

Product Specification

Appendix 1-2.

■ REQUIRED SIGNAL ASSIGNMENT FOR LVDS TRANSMITTER (Pin9="H")

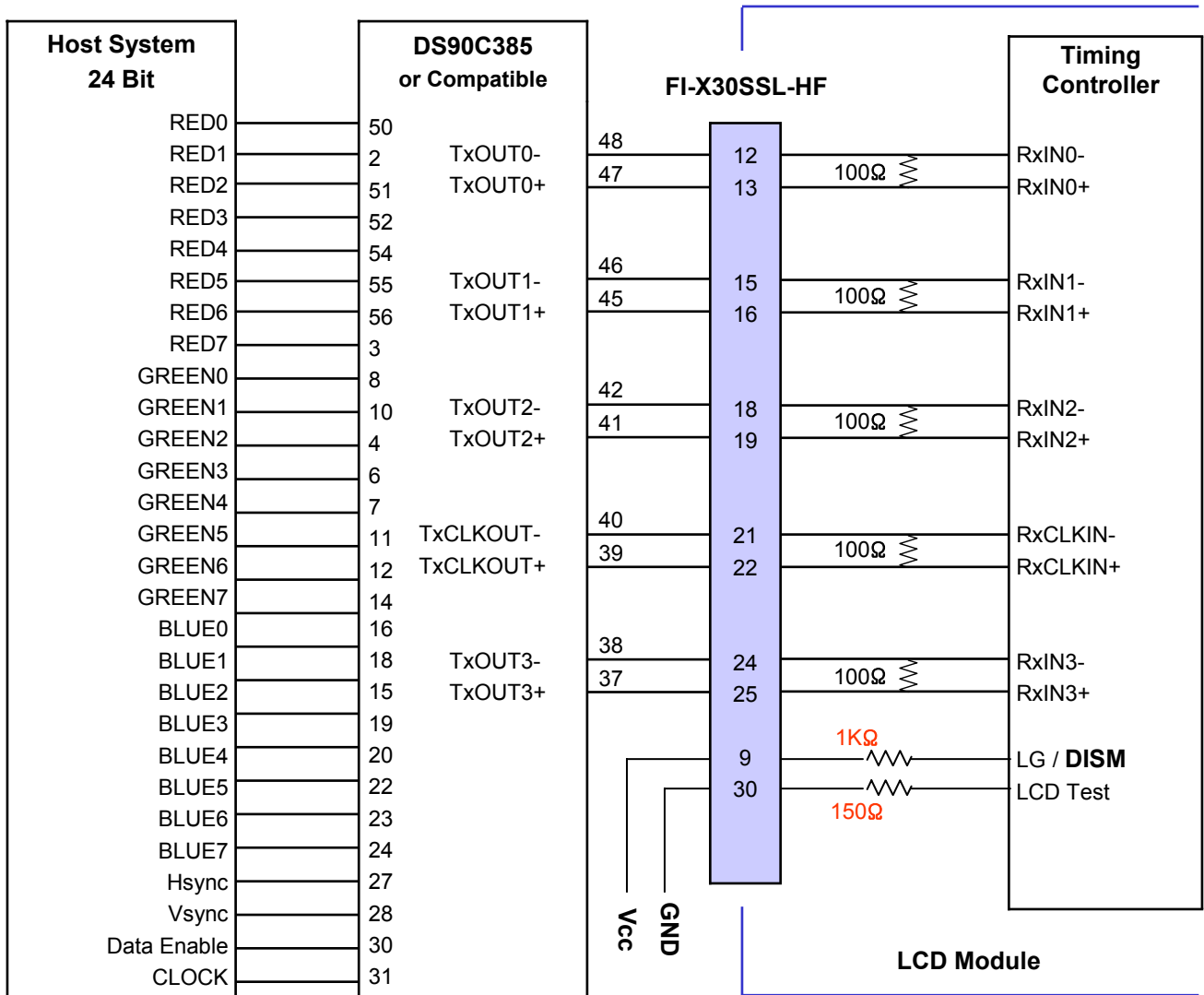

- Note: 1. The LCD Module uses a 100 Ohm[Ω] resistor between positive and negative lines of each receiver input.
 2. Refer to LVDS Transmitter Data Sheet for detail descriptions. (DS90C385 or Compatible)
 3. '7' means MSB and '0' means LSB at R,G,B pixel data.

Appendix 2. LC370WX4-SLA1 Packing Ass'y

■LC370WX4-SLA1 Packing Ass'y

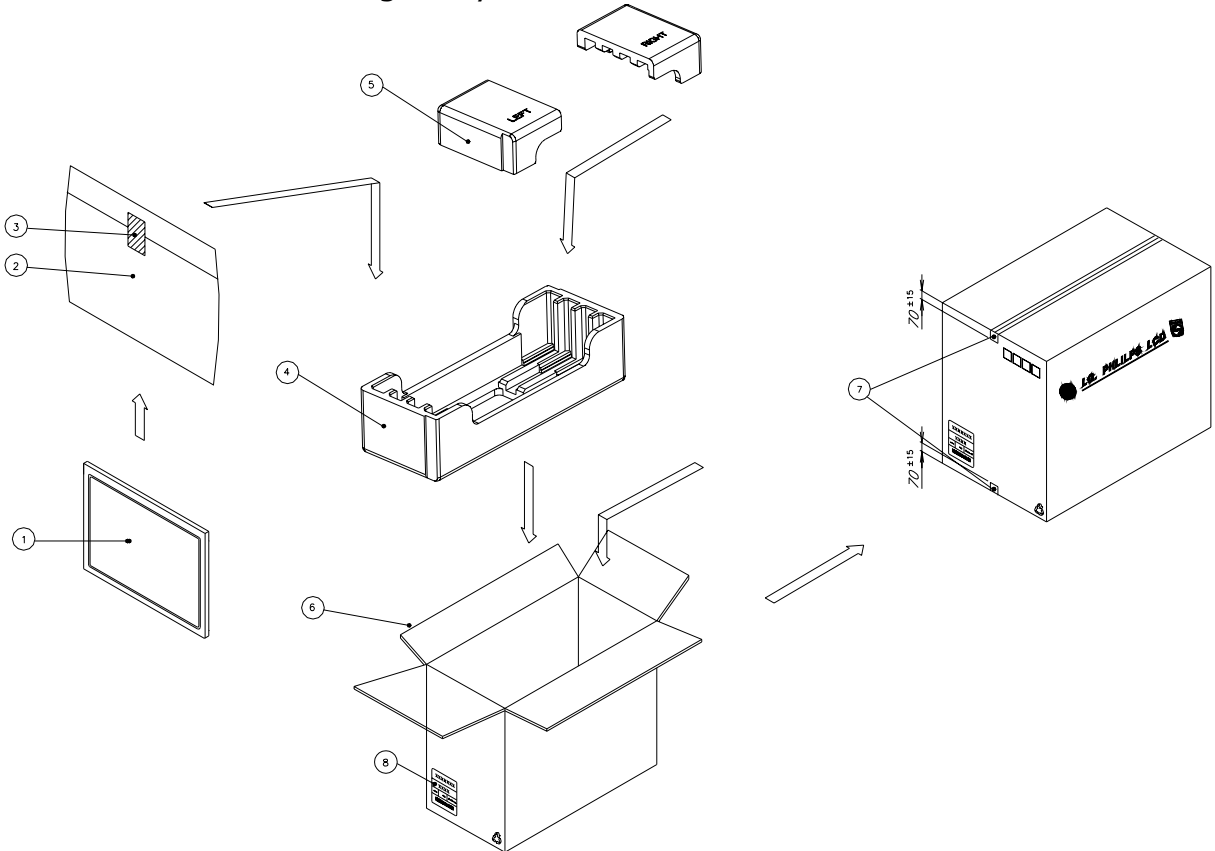

NO.	DESCRIPTION	MATERIAL
1	LCD MODULE	
2	BAG	AL
3	TAPE	MASKING 20MM X 50M
4	PACKING, BOTTOM	EPS
5	PACKING, TOP R_L	EPS
6	BOX	PAPER_DW3
7	TAPE	OPP 70MMX300M
8	LABEL	YUPO PAPER 100X100

Appendix 3. LC370WX4-SLA1 Pallet Ass'y

■ LC370WX4-SLA1 Pallet Ass'y

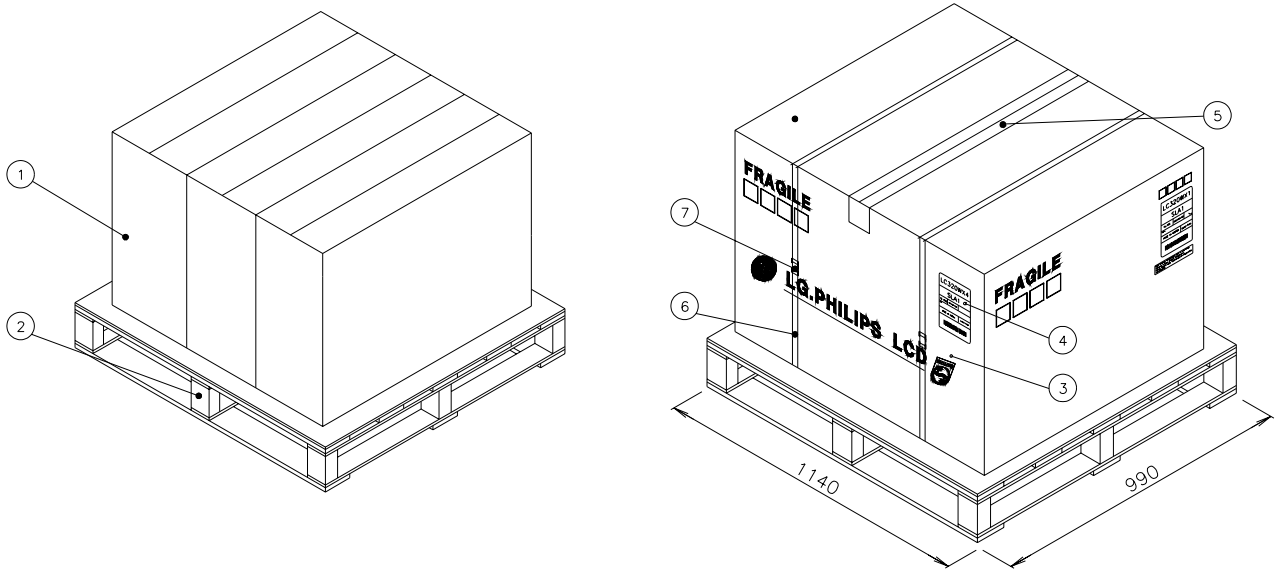

NO.	DESCRIPTION	MATERIAL
1	PACKING ASS'Y	
2	PALLET	Plywood_1140X990X130
3	ANGLE, PACKING	SWR4
4	LABEL	YUPO PAPER
5	TAPE	OPP
6	BAND	PP
7	BAND, CLIP	CLIP 18MM

Appendix 4. LCM Label & Serial No. format

■ LCM Label

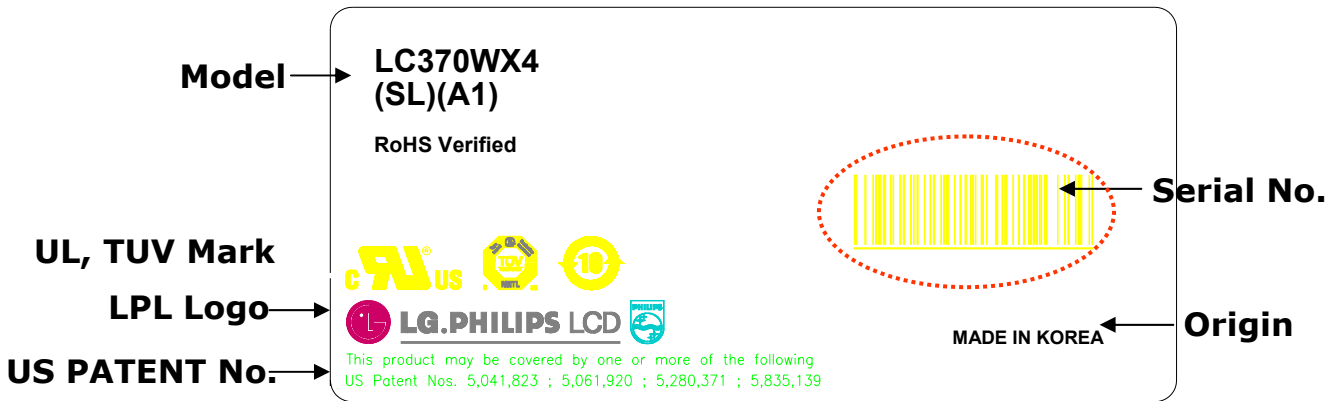

Appendix 5. Box Label & Pallet Label format

■ Box Label

LC370WX4		
SLA1		
4 PCS	001/01-01	
MADE IN KOREA		RoHS Verified
 ***** **		

■ Pallet Label

LC370WX4	
SLA1	
12 PCS	001/01-01
REMARK	
MADE IN KOREA	RoHS Verified
 ***** **	

Appendix 6-1

■ LCM DCR Only

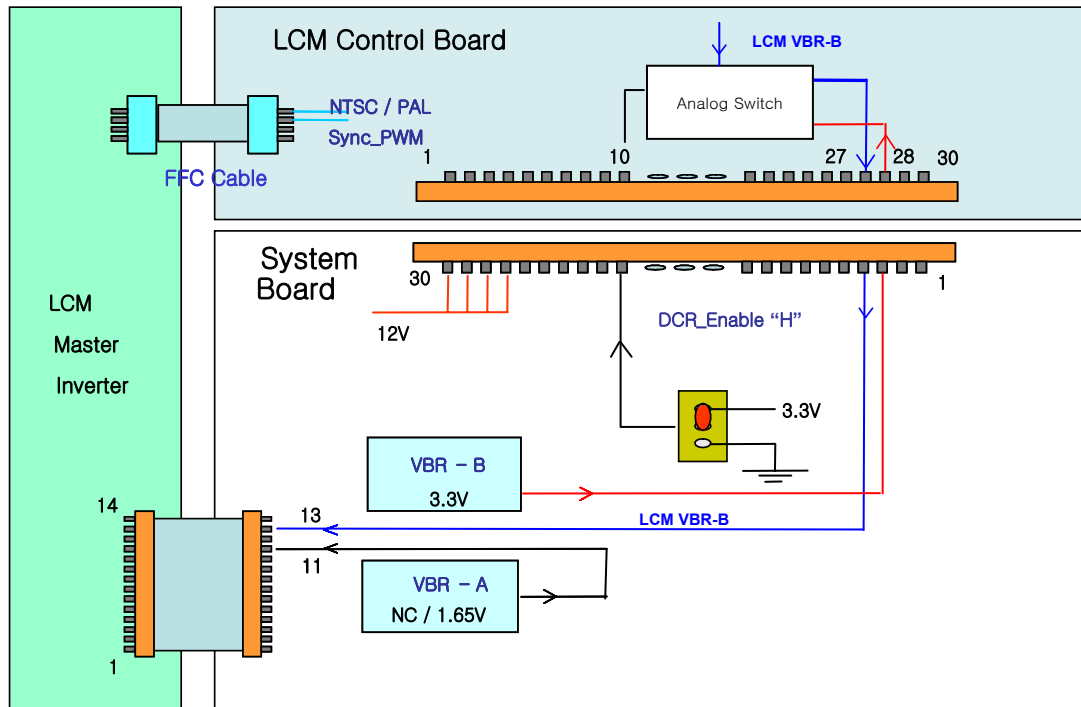

DCR_Enable	On(3.3V)	Off (0V)
V _{BR} -B	0V ~ 3.3V	3.3V
V _{BR} -A	1.65V or NC	1.65V or NC
DCR Level	2000 : 1	1000 : 1

Gray Level	Luminance [%] DCR On VBR-A = 1.65V
L0	0.05
L15	0.33
L31	1.10
L47	2.81
L63	5.40
L79	8.5
L95	12.4
L111	16.7
L127	21.3
L143	27.4
L159	34.6
L175	43.0
L191	52.4
L207	63.0
L223	74.5
L239	86.8
L255	100

Appendix 6-2

■ System DCR (Dynamic Contrast Ratio)- Max 5000:1

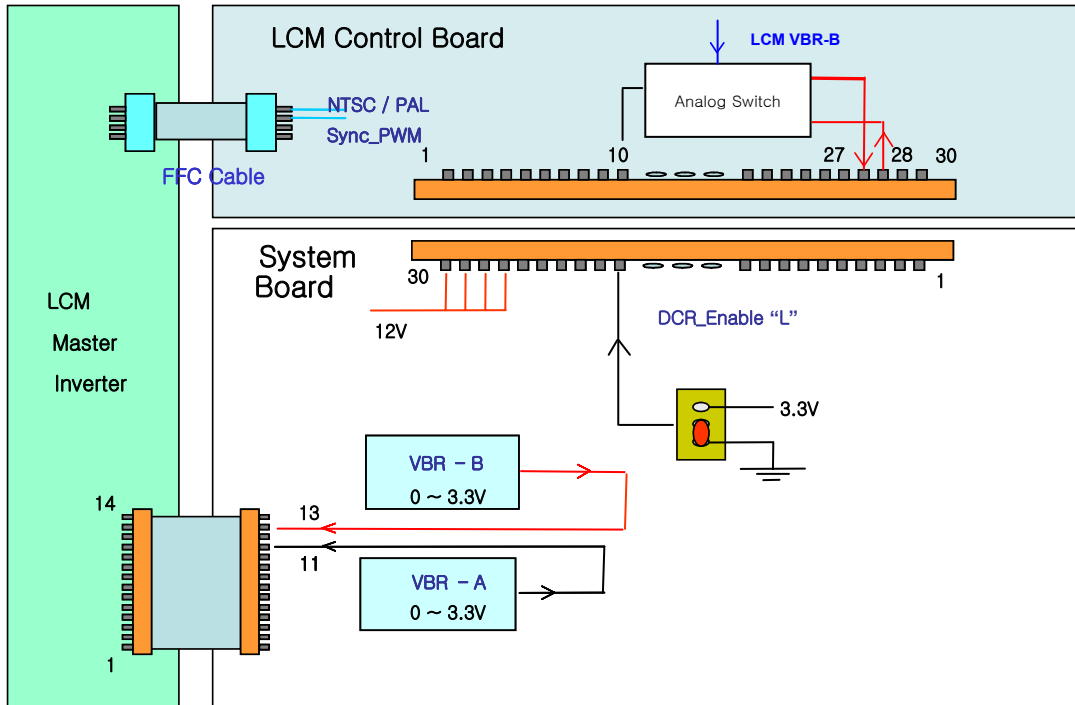

V_{BR-B}	0V ~ 3.3V	3.3V
V_{BR-A}	0V ~ 3.3V	1.65V
DCR Level	5000 : 1	1000 : 1

Note : 1. To make DCR Max 5000:1, V_{BR-A} and V_{BR-B} must be given by system.

2. DCR Max 5000:1 is defined mathematically as :
 $DCR = \text{Maximum } DCR_n (n=1, 2, 3, 4, 5)$

$$DCR_n = \frac{\text{Surface Luminance at position } n \text{ with all white pixels } (V_{BR-B}=3.3V, V_{BR-A}=3.3V)}{\text{Surface Luminance at position } n \text{ with all black pixels } (V_{BR-B}=0V, V_{BR-A}=0V)}$$

n = the Position number(1, 2, 3, 4, 5). For more information, see FIG 2.