



LC370WXE

Product Specification

SPECIFICATION FOR APPROVAL

(●) Preliminary Specification

() Final Specification

Title	37.0" WXGA TFT LCD
-------	--------------------

BUYER	
MODEL	

SUPPLIER	LG Display Co., Ltd.
*MODEL	LC370WXE
SUFFIX	SBA1

*When you obtain standard approval,
please use the above model name without suffix

APPROVED BY	SIGNATURE DATE
/	
/	
/	
Please return 1 copy for your confirmation with your signature and comments.	

APPROVED BY	SIGNATURE DATE
J.H. Lee /Team Leader	
REVIEWED BY	
J.Y. Lee / Project Leader	
PREPARED BY	
J.T. Kim / Engineer	
TV Product Development Dept. LG Display Co., Ltd.	

Product Specification

CONTENTS

Number	ITEM	Page
	COVER	1
	CONTENTS	2
	RECORD OF REVISIONS	3
1	GENERAL DESCRIPTION	4
2	ABSOLUTE MAXIMUM RATINGS	5
3	ELECTRICAL SPECIFICATIONS	6
3-1	ELECTRICAL CHARACTERISTICS	6
3-2	INTERFACE CONNECTIONS	10
3-3	SIGNAL TIMING SPECIFICATIONS	12
3-4	SIGNAL TIMING WAVEFORMS	13
3-5	COLOR DATA REFERENCE	14
3-6	POWER SEQUENCE	15
4	OPTICAL SPECIFICATIONS	16
5	MECHANICAL CHARACTERISTICS	20
6	RELIABILITY	23
7	INTERNATIONAL STANDARDS	24
7-1	SAFETY	24
7-2	EMC	24
8	PACKING	25
8-1	DESIGNATION OF LOT MARK	25
8-2	PACKING FORM	25
9	PRECAUTIONS	26
9-1	MOUNTING PRECAUTIONS	26
9-2	OPERATING PRECAUTIONS	26
9-3	ELECTROSTATIC DISCHARGE CONTROL	27
9-4	PRECAUTIONS FOR STRONG LIGHT EXPOSURE	27
9-5	STORAGE	27
9-6	HANDLING PRECAUTIONS FOR PROTECTION FILM	27

LC370WXE

Product Specification

1. General Description

The LC370WXN is a Color Active Matrix Liquid Crystal Display with an integral External Electrode Fluorescent Lamp(EEFL) backlight system. The matrix employs a-Si Thin Film Transistor as the active element. It is a transmissive display type which is operating in the normally black mode. It has a 37.02 inch diagonally measured active display area with WXGA resolution (768 vertical by 1366 horizontal pixel array). Each pixel is divided into Red, Green and Blue sub-pixels or dots which are arrayed in vertical stripes. Gray scale or the luminance of the sub-pixel color is determined with a 8-bit gray scale signal for each dot. Therefore, it can present a palette of more than 16.7M(true) colors.

It has been designed to apply the 8-bit 1-port LVDS interface.

It is intended to support LCD TV, PCTV where high brightness, super wide viewing angle, high color gamut, high color depth and fast response time are important.

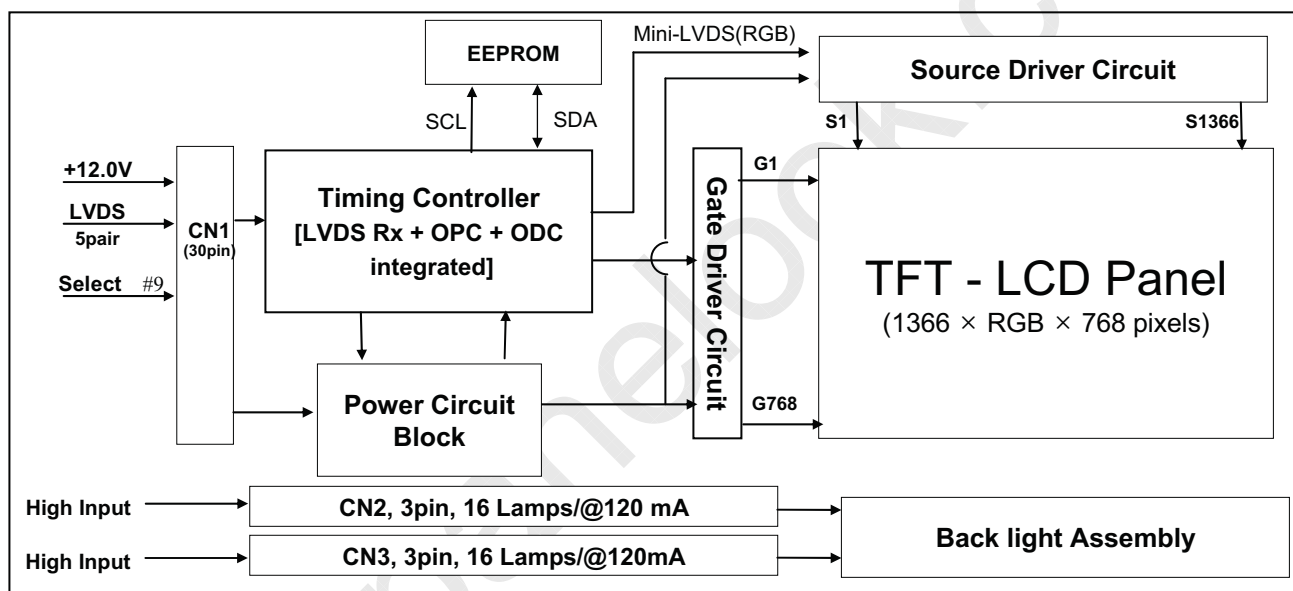

General Features

Active Screen Size	37.02 inches(940.3mm) diagonal
Outline Dimension	877.0mm(H) x 516.8mm(V) x 46.9mm(D) (Typ.)
Pixel Pitch	0.200mm x 0.600mm x RGB
Pixel Format	1366 horiz. by 768 vert. pixels RGB stripe arrangement
Color Depth	8-bit, 16.7 M colors
Luminance, White	500 cd/m ² (Center 1 point Typ.)
Viewing Angle (CR>10)	Viewing angle free (R/L 178(Typ.), U/D 178(Typ.))
Power Consumption	Total 123.8 Watt (Typ.) (Logic= 3.8 W, Inverter= 120W @ with inverter)
Weight	7,500 g (Typ.) (TBD)
Display Mode	Transmissive mode, Normally black
Surface Treatment	Hard coating (3H), Anti-reflection treatment of the front polarizer (Reflectance : < 2%)

Ver. 0.1

4 / 39

LC370WXE

Product Specification

2. Absolute Maximum Ratings

The following items are maximum values which, if exceeded, may cause faulty operation or damage to the LCD module.

Table 1. ABSOLUTE MAXIMUM RATINGS

Parameter		Symbol	Value		Unit	Remark
			Min	Max		
Power Input Voltage	LCD circuit	V _{LCD}	-0.3	+14.0	V [DC]	at 25 ± 2 °C
B/L Input voltage	Operating Voltage (one side)	V _{OP}	700	1100	V [RMS]	at 25 ± 2 °C
Operating Temperature		T _{OP}	0	+50	°C	Note 1
Storage Temperature		T _{ST}	-20	+60	°C	
Operating Ambient Humidity		H _{OP}	10	90	%RH	
Storage Humidity		H _{ST}	10	90	%RH	

- Notes : 1. Temperature and relative humidity range are shown in the figure below.
 Wet bulb temperature should be Max 39 °C and no condensation of water.
 2. Gravity mura can be guaranteed below 40 °C condition.

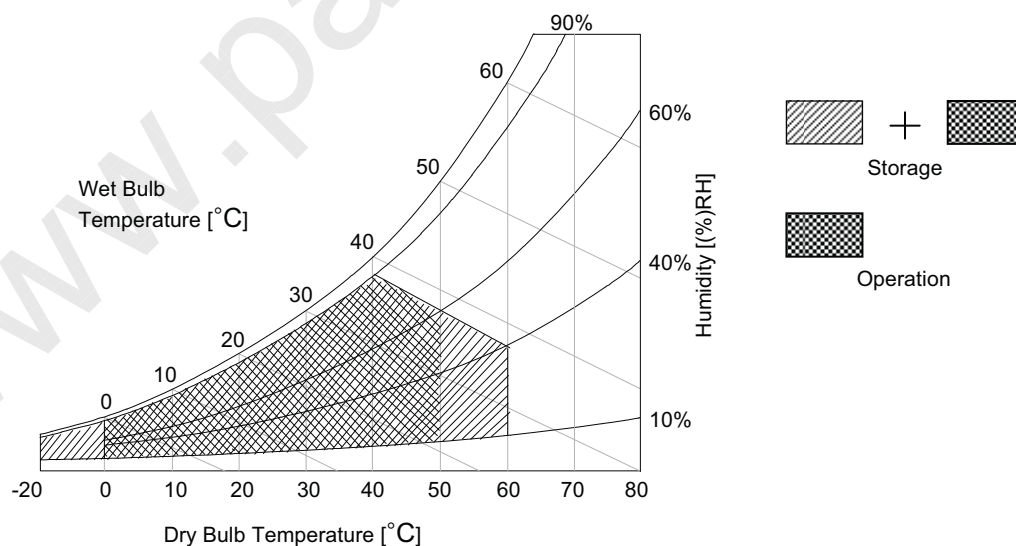

Product Specification

3. Electrical Specifications

3-1. Electrical Characteristics

It requires two power inputs. One is employed to power for the LCD circuit. The other is used for the EEFL backlight and inverter circuit.

Table 2. ELECTRICAL CHARACTERISTICS

Parameter	Symbol	Value			Unit	Note
		Min	Typ	Max		
Circuit :						
Power Input Voltage	V _{LCD}	10.8	12.0	13.2	V _{DC}	
Power Input Current	I _{LCD}	-	326	424	mA	1
		-	420	546	mA	2
Power Consumption	P _{LCD}	-	3.9	5.1	Watt	1
Rush current	I _{RUSH}	-	-	3.0	A	3

- Notes :
1. The specified current and power consumption are under the $V_{LCD}=12.0V$, $25 \pm 2^{\circ}C$, $f_V=60Hz$ condition whereas mosaic pattern(8 x 6) is displayed and f_V is the frame frequency.
 2. The current is specified at the maximum current pattern.
 3. The duration of rush current is about 2ms and rising time of power input is **0.5ms** (min)

White : 255Gray
Black : 0Gray

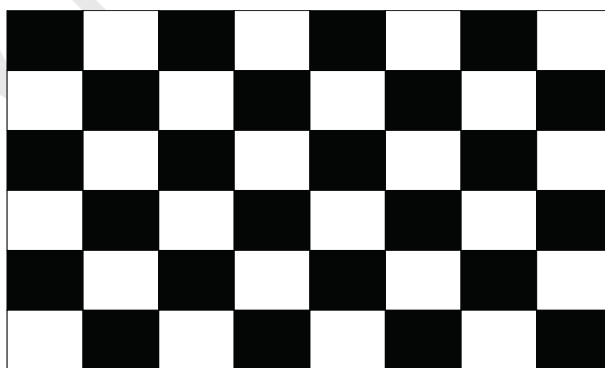

Mosaic Pattern(8 x 6)

LC370WXE

Product Specification

Table 3. ELECTRICAL CHARACTERISTICS (Continue)

Parameter	Symbol	Values			Unit	Notes
		Min	Typ	Max		
Backlight Assembly :						
Operating Voltage (one side, fBL=63KHz, IBL= 120mArms)	VBL	-	950	-	V _{RMS}	1, 2
Operating Current (one side)	IBL	-	120	-	mA _{RMS}	1
Established Starting Voltage (one side)	Vs	0°C	-	1125	V _{RMS}	1, 3
		25°C	-	1000		
Operating Frequency	fBL	61	63	65	kHz	4
Striking Time	S TIME	-	-	1.5	sec	3
Power Consumption	PBL		120		Watt	6
Burst Dimming Duty	PWM duty	20		100	%	9
Burst Dimming Frequency	1/T	95	-	182	Hz	9

Parameter	Symbol	Values			Unit	Notes
		Min	Typ	Max		
Lamp : APPENDIX-IX						
Lamp Voltage (one side)	VLAMP	765	975	1050	V _{RMS}	2
Lamp Current (one side)	ILAMP	3.0	7.0	8.0	mA _{RMS}	
Discharge Stabilization Time	TS	-	-	3	Min	5
Lamp Frequency	f LAMP	40	63	80	KHz	
Lamp Temperature	TLAMP		70		°C	
Established Starting Voltage (one side)	Vs	0°C		1150	V _{RMS}	3
		25°C		960		
Life Time		50,000			Hrs	7

Notes : The design of the inverter must have specifications for the lamp in LCD Assembly.

The electrical characteristics of inverter are based on High-High Driving type.

The performance of the lamps in LCM, for example life time or brightness, is extremely influenced by the characteristics of the DC-AC inverter. So, all the parameters of an inverter should be carefully designed so as not to produce too much leakage current from high-voltage output of the inverter.

When you design or order the inverter, please make sure unwanted lighting caused by the mismatch of the lamp and the inverter (no lighting, flicker, etc) has never been occurred. When you confirm it, the LCD- Assembly should be operated in the same condition as installed in your instrument.

※ Do not attach a conductive tape to lamp connecting wire.

If you attach conductive tape to the lamp wire, not only luminance level can be lower than typical one but also inverter operate abnormally on account of leakage current which is generated between lamp wire and conductive tape.

1. Specified values are defined for a Backlight Assembly.(IBL : 16 lamp, 7.5mA/Lamp)

2. Operating voltage is measured at $25 \pm 2^\circ\text{C}$ (after 2hr.aging). The variance range for operating voltage is $\pm 10\%$.

3. The established starting voltage [Vs] should be applied to the lamps for more than Striking time (S TIME) for start-up. Inverter open voltage must be more than established starting voltage. Otherwise, the lamps may not be turned on. The used lamp current is typical value.

Product Specification

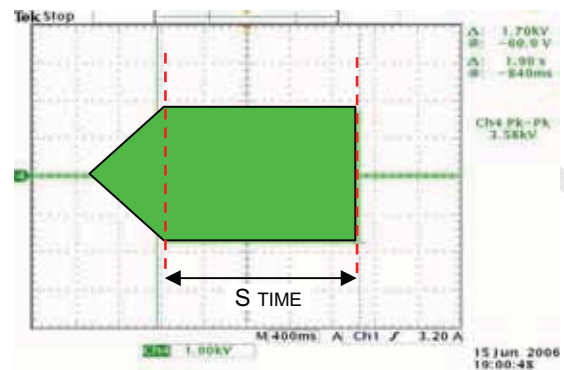
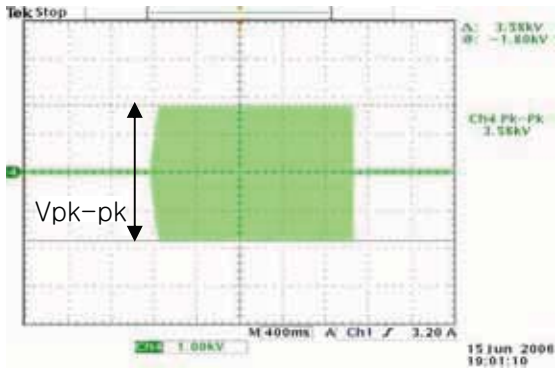

$$V_s = (V_{pk-pk}) / [2 \cdot \sqrt{2}]$$

4. Lamp frequency may produce interference with horizontal synchronous frequency. As a result, the may cause beat on the display. Therefore, lamp frequency shall be away as much as possible from the horizontal synchronous frequency and its harmonics range in order to prevent interference.
5. The brightness of the lamp after lighted for 5minutes is defined as 100%.
 T_s is the time required for the brightness of the center of the lamp to be not less than 95% at typical current.
 The screen of LCD module may be partially dark by the time the brightness of lamp is stable after turn on.
6. Maximum level of power consumption is measured at initial turn on.
 Typical level of power consumption is measured after 2hrs aging at $25 \pm 2^\circ\text{C}$.
7. The life time is determined as the time at which brightness of the lamp is 50% compared to that of initial value at the typical lamp current on condition of continuous operating at $25 \pm 2^\circ\text{C}$, based on duty 100%.
8. The output of the inverter must have symmetrical(negative and positive) voltage and current waveform (Unsymmetrical ratio is less than 10%). Please do not use the inverter which has not only unsymmetrical voltage and current but also spike wave.

Requirements for a system inverter design, which is intended to achieve better display performance, power efficiency and more reliable lamp characteristics.

It can help increase the lamp lifetime and reduce leakage current.

- a. The asymmetry rate of the inverter waveform should be less than 10%.
- b. The distortion rate of the waveform should be within $\sqrt{2} \pm 10\%$.

* Inverter output waveform had better be more similar to ideal sine wave.

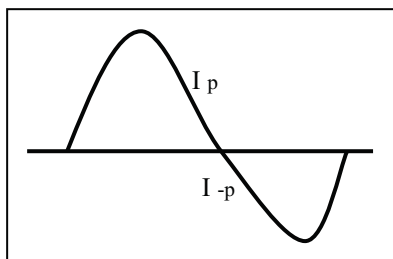

* Asymmetry rate:

$$|I_p - I_{-p}| / I_{op} \times 100\%$$

* Distortion rate

$$I_p \text{ (or } I_{-p}) / I_{op}$$

Product Specification

9. The reference method of burst dimming duty ratio.

It is recommended to use synchronous V-sync frequency to prevent waterfall
(Vsync x 2 =Burst Frequency)

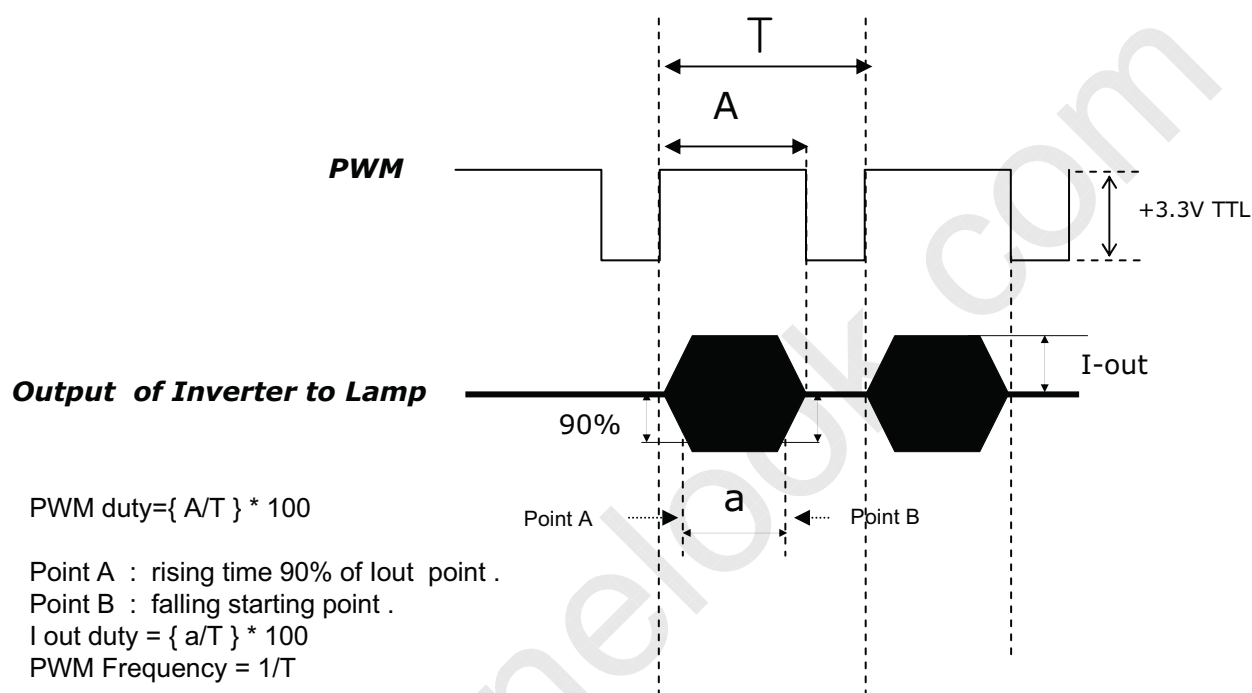

※ We recommend not to be much different between PWM duty and Iout duty .

※ Dimming current output rising and falling time may produce humming and inverter trans' sound noise.

※ Burst dimming duty should be 100% for more than 1second after turn on.

※ Equipment

Oscilloscope :TDS3054B(Tektronix)

Current Probe : P6022 AC (Tektronix)

High Voltage Probe: P5100(Tektronix)

10. The Cable between the backlight connector and its inverter power supply should be connected directly with a minimized length. The longer cable between the backlight and the inverter may cause the lower luminance of lamp and may require more higher starting voltage (Vs).

11. The operating current must be measured as near as backlight assembly input.

12. The operating current unbalance between left and right must be under 10% of Typical current
| Left(Master) current – Right(Slave) Current | < 10% of typical current

Product Specification

3-2. Interface Connections

This LCD module employs two kinds of interface connection, a 30-pin connector is used for the module electronics and 14-pin connector is used for the integral backlight system.

3-2-1. LCD Module

- LCD Connector(CN5) : FI-X30SSL-HF (Manufactured by JAE) or IS100-L30B-C23(Manufactured by UJU)
- Mating Connector : FI-X30C2L (Manufactured by JAE) or Equivalent

Table 4. MODULE CONNECTOR(CN5) PIN CONFIGURATION

Pin No.	Symbol	Description	Note
1	VLCD	Power Supply +12.0V	
2	VLCD	Power Supply +12.0V	
3	VLCD	Power Supply +12.0V	
4	VLCD	Power Supply +12.0V	
5	GND	Ground	
6	GND	Ground	
7	GND	Ground	
8	GND	Ground	
9	LVDS Select	'H' =JEIDA , 'L' or NC = VESA	Appendix VII
10	NC	No Connection	
11	GND	Ground	
12	RA-	LVDS Receiver Signal(-)	
13	RA+	LVDS Receiver Signal(+)	
14	GND	Ground	
15	RB-	LVDS Receiver Signal(-)	
16	RB+	LVDS Receiver Signal(+)	
17	GND	Ground	
18	RC-	LVDS Receiver Signal(-)	
19	RC+	LVDS Receiver Signal(+)	
20	GND	Ground	
21	RCLK-	LVDS Receiver Clock Signal(-)	
22	RCLK+	LVDS Receiver Clock Signal(+)	
23	GND	Ground	
24	RD-	LVDS Receiver Signal(-)	
25	RD+	LVDS Receiver Signal(+)	
26	GND	Ground	
27	NC	No Connection	
28	NC	No Connection	
29	GND	Ground	
30	GND	Ground	

- Notes :
1. All GND(ground) pins should be connected together to the LCD module's metal frame.
 2. All VLCD (power input) pins should be connected together.
 3. All Input levels of LVDS signals are based on the **EIA 644** Standard. (Please see the Appendix VI)
 4. Specific pin No. **#30** is used for "No signal detection" of system signal interface.
It should be GND for **NSB(No Signal Black)** during the system interface signal is not.
If this pin is "H", LCD Module displays **AGP(Auto Generation Pattern)**.

LC370WXE

Product Specification

3-2-2. Backlight Inverter

[Master]

1) Balance Connector

: 65002WS-03 (manufactured by YEONHO) or equivalent

2) Mating Connector

: 65002HS-03 (manufactured by YEONHO) or equivalent.

[Slave]

1) Balance Connector

: 65002WS-03 (manufactured by YEONHO) or equivalent

2) Mating Connector

: 65002HS-03 (manufactured by YEONHO) or equivalent.

Table 5. BACKLIGHT CONNECTOR PIN CONFIGURATION(CN2,CN3)

No	Symbol	Master	Slave	Note
1	H_Input	High_Input	High_Input	
2	H_Input	High_Input	High_Input	
3	FB	NC	NC	

◆ Rear view of LCM

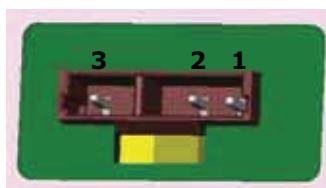

Master

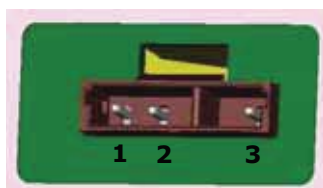

Slave

LC370WXE

Product Specification

3-3. Signal Timing Specifications

Table 6 shows the signal timing required at the input of the LVDS transmitter. All of the interface signal timings should be satisfied with the following specification for normal operation.

Table 6. TIMING TABLE for NTSC &PAL

[DE (Data Enable) Only]

ITEM	Symbol		Min	Typ	Max	Unit	Note
DCLK	Period	tCLK	12.5	13.8	15.8	ns	
	Frequency	-	63	72.4	80	MHz	
Hsync	Period	tHT	1456	1528	1920	tCLK	
	Horizontal Valid	tHV	1366	1366	1366	tCLK	
	Horizontal Blank	-	tHP- tHV	162	tHP- tHV		
	Frequency	fH	45	47.4	50	KHz	
	Width	tWH	-	32	-	tCLK	
	Horizontal Back Porch	tHBP	24	48	-		
	Horizontal Front Porch	tHFP	40	80	-		
Vsync	Period	tVT	776 (894)	790 (948)	1063 (1008)	tHP	Note 1) NTSC : 57~63Hz (PAL : 47~53Hz)
	Vertical Valid	tVV	768	768	768	tHP	
	Vertical Blank	-	tVP- tVV	22	tVP- tVV	tHP	
	Frequency	fV	57 (47)	60 (50)	63 (53)	Hz	
	Width	tWV	-	5 (12)	-	tHP	
	Vertical Back Porch	tVBP	5	15 (128)	-	Hz	
	Vertical Front Porch	tVFP	1	2 (40)	-	tHP	

Note :

1. The input of HSYNC & VSYNC signal does not have an effect on normal operation(DE Only Mode). If you use spread spectrum of EMI, add some additional clock to minimum value for clock margin.
2. The performance of the electro-optical characteristics may be influenced by variance of the vertical refresh rate and the horizontal frequency
3. Timing should be set based on clock frequency.

3-4. Signal Timing Waveforms

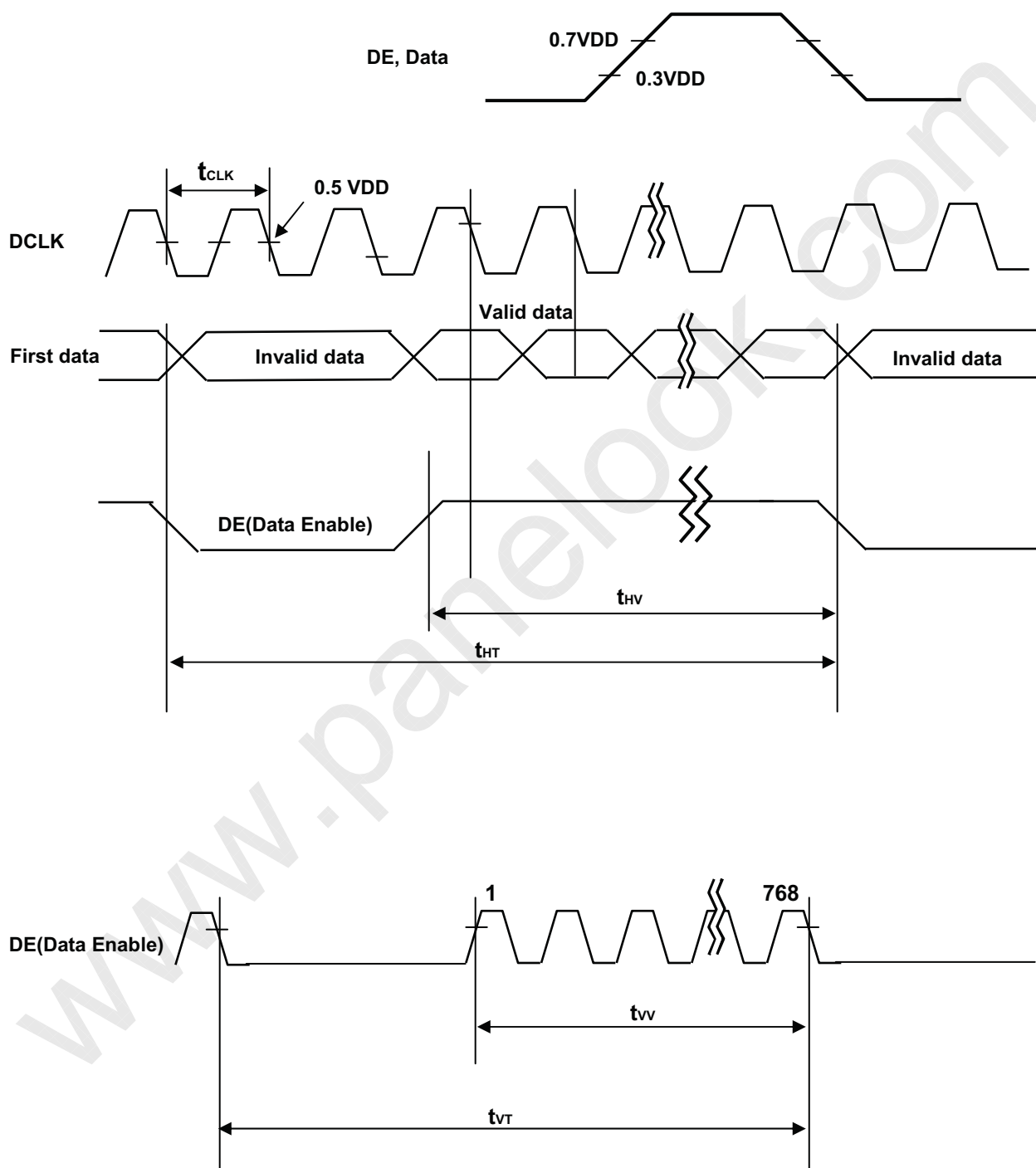

Product Specification

3-5. Color Data Reference

The brightness of each primary color(red,green,blue) is based on the 8-bit gray scale data input for the color. The higher binary input, the brighter the color. Table 7 provides a reference for color versus data input.

Table 7. COLOR DATA REFERENCE

Color		Input Color Data																							
		RED								GREEN								BLUE							
		MSB				LSB				MSB				LSB				MSB				LSB			
		R7	R6	R5	R4	R3	R2	R1	R0	G7	G6	G5	G4	G3	G2	G1	G0	B7	B6	B5	B4	B3	B2	B1	B0
Basic Color	Black	0	0	0	0	0	0	0	0	0	0	0	0	0	0	0	0	0	0	0	0	0	0	0	0
	Red (255)	1	1	1	1	1	1	1	1	0	0	0	0	0	0	0	0	0	0	0	0	0	0	0	0
	Green (255)	0	0	0	0	0	0	0	0	1	1	1	1	1	1	1	1	0	0	0	0	0	0	0	0
	Blue (255)	0	0	0	0	0	0	0	0	0	0	0	0	0	0	0	0	1	1	1	1	1	1	1	1
	Cyan	0	0	0	0	0	0	0	0	1	1	1	1	1	1	1	1	1	1	1	1	1	1	1	1
	Magenta	1	1	1	1	1	1	1	1	0	0	0	0	0	0	0	0	1	1	1	1	1	1	1	1
	Yellow	1	1	1	1	1	1	1	1	1	1	1	1	1	1	1	1	0	0	0	0	0	0	0	0
	White	1	1	1	1	1	1	1	1	1	1	1	1	1	1	1	1	1	1	1	1	1	1	1	1
RED	RED (000) Dark	0	0	0	0	0	0	0	0	0	0	0	0	0	0	0	0	0	0	0	0	0	0	0	0
	RED (001)	0	0	0	0	0	0	0	1	0	0	0	0	0	0	0	0	0	0	0	0	0	0	0	0
							
	RED (254)	1	1	1	1	1	1	1	0	0	0	0	0	0	0	0	0	0	0	0	0	0	0	0	0
	RED (255)	1	1	1	1	1	1	1	1	0	0	0	0	0	0	0	0	0	0	0	0	0	0	0	0
GREEN	GREEN (000) Dark	0	0	0	0	0	0	0	0	0	0	0	0	0	0	0	0	0	0	0	0	0	0	0	0
	GREEN (001)	0	0	0	0	0	0	0	0	0	0	0	0	0	0	0	1	0	0	0	0	0	0	0	0
							
	GREEN (254)	0	0	0	0	0	0	0	0	1	1	1	1	1	1	1	0	0	0	0	0	0	0	0	0
	GREEN (255)	0	0	0	0	0	0	0	0	1	1	1	1	1	1	1	1	0	0	0	0	0	0	0	0
BLUE	BLUE (000) Dark	0	0	0	0	0	0	0	0	0	0	0	0	0	0	0	0	0	0	0	0	0	0	0	0
	BLUE (001)	0	0	0	0	0	0	0	0	0	0	0	0	0	0	0	0	0	0	0	0	0	0	0	1
							
	BLUE (254)	0	0	0	0	0	0	0	0	0	0	0	0	0	0	0	0	1	1	1	1	1	1	1	0
	BLUE (255)	0	0	0	0	0	0	0	0	0	0	0	0	0	0	0	0	1	1	1	1	1	1	1	1

LC370WXE

Product Specification

3-6. Power Sequence

3-6-1. LCD Driving circuit

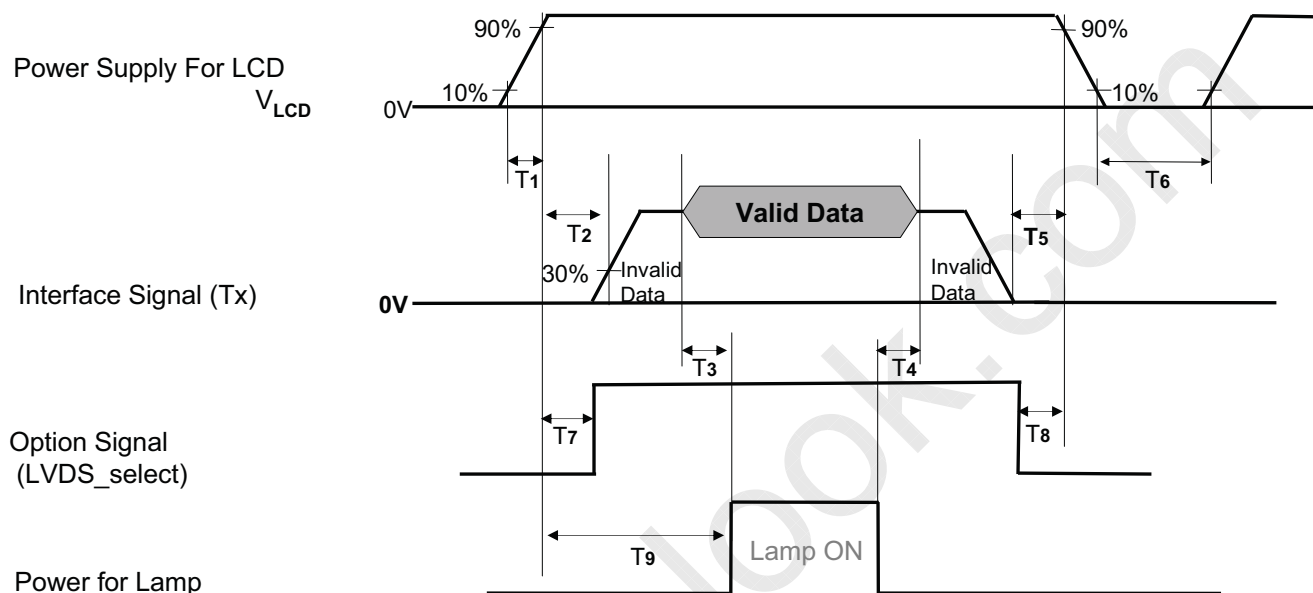

Table 8. POWER SEQUENCE

Parameter	Value			Unit	Notes
	Min	Typ	Max		
T1	0.5	-	20	ms	
T2	0.5	-	-	ms	4, 5
T3	200	-	-	ms	3
T4	200	-	-	ms	3
T5	0	-	-	ms	
T6	2.0	-	-	s	6
T7	0.5	-	T2	ms	4
T8	0	-	-	ms	4
T9	$T_2 + T_3$	-	5	s	

- Note :
1. Please avoid floating state of interface signal at invalid period.
 2. When the interface signal is invalid, be sure to pull down the power supply V_{LCD} to 0V.
 3. The T3/T4 is recommended value, the case when failed to meet a minimum specification, abnormal display would be shown. There is no reliability problem.
 4. If the on time of signals (Interface signal and Option signals) precedes the on time of Power (V_{LCD}), it will be happened abnormal display.
 6. T6 should be measured after the Module has been fully discharged between power off and on period.

LC370WXE

Product Specification

4. Optical Specification

Optical characteristics are determined after the unit has been 'ON' and stable in a dark environment at $25\pm 2^{\circ}\text{C}$. The values specified are at an approximate distance 50cm from the LCD surface at a viewing angle of Φ and θ equal to 0° .

FIG. 1 shows additional information concerning the measurement equipment and method.

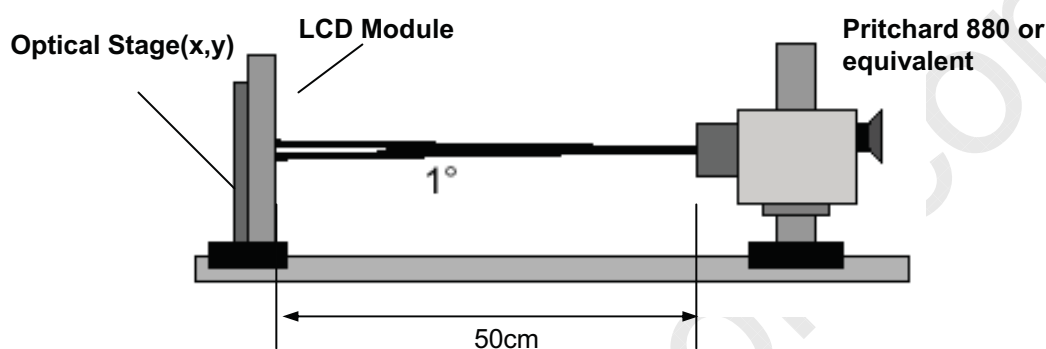

FIG. 1 Optical Characteristic Measurement Equipment and Method

$T_a = 25\pm 2^{\circ}\text{C}$, $V_{\text{LCD}} = 12.0\text{V}$, $f_v = 60\text{Hz}$, $D_{\text{clk}} = 72\text{MHz}$, $V_{\text{BR_A}} = 1.65\text{V}$, $\text{EXTV}_{\text{BR_B}} = 100\%$

Table 10. OPTICAL CHARACTERISTICS

Parameter	Symbol	Value			Unit	Note	
		Min	Typ	Max			
Contrast Ratio	CR	800	1200	-		1	
Surface Luminance, white	L_{WH}	400	500	-	cd/m^2	2	
Luminance Variation	δ_{WHITE} 5P	-	-	1.3		3	
Response Time	Gray-to-Gray	G to G	-	5	8	ms	4
	Uniformity	$\delta_{\text{G TO G}}$	-	-	1		5
Color Coordinates [CIE1931]	RED	Rx	Typ -0.03	0.636	Typ +0.03		
		Ry		0.335			
	GREEN	Gx		0.290			
		Gy		0.610			
	BLUE	Bx		0.144			
		By		0.063			
	WHITE	Wx		0.279			
Wy	0.292						
Viewing Angle (CR>10)							
	x axis, right ($\phi=0^{\circ}$)	θ_r	89	-	-	degree	6
	x axis, left ($\phi=180^{\circ}$)	θ_l	89	-	-		
	y axis, up ($\phi=90^{\circ}$)	θ_u	89	-	-		
	y axis, down ($\phi=270^{\circ}$)	θ_d	89	-	-		
Gray Scale			-	-	-		7

LC370WXE

Product Specification

Notes :1. Contrast Ratio(CR) is defined mathematically as :

$$\text{CR(Contrast Ratio)} = \frac{\text{Maximum CRn (n=1, 2, 3, 4, 5)}}{\text{Surface Luminance at position n with all white pixels}}$$

$$\text{CRn} = \frac{\text{Surface Luminance at position n with all black pixels}}{\text{Surface Luminance at position n with all white pixels}}$$

n = the Position number(1, 2, 3, 4, 5). For more information,

- Surface luminance is determined after the unit has been 'ON' and 1Hour after lighting the backlight in a dark environment at $25 \pm 2^\circ\text{C}$. Surface luminance is the luminance value at center 1-point across the LCD surface 50cm from the surface with all pixels displaying white. For more information see the FIG. 2.
- The variation in surface luminance, δ WHITE is defined as :

$$\delta \text{ WHITE}(5P) = \frac{\text{Maximum}(L_{\text{on}1}, L_{\text{on}2}, L_{\text{on}3}, L_{\text{on}4}, L_{\text{on}5})}{\text{Minimum}(L_{\text{on}1}, L_{\text{on}2}, L_{\text{on}3}, L_{\text{on}4}, L_{\text{on}5})}$$
 Where $L_{\text{on}1}$ to $L_{\text{on}5}$ are the luminance with all pixels displaying white at 5 locations .
 For more information, see the FIG. 2.
- Response time is the time required for the display to transit from G(N) to G(M) (Rise Time, Tr_R) and from G(M) to G(N) (Decay Time, Tr_D). For additional information see the FIG. 3. (N<M)
 ※ G to G Spec stands for average value of all measured points.
 Photo Detector : RD-80S / Field : 2°
- Gray to Gray Response time uniformity is Reference data. Please see Appendix-VIII.
- Viewing angle is the angle at which the contrast ratio is greater than 10. The angles are determined for the horizontal or x axis and the vertical or y axis with respect to the z axis which is normal to the LCD module surface. For more information, see the FIG. 4.
- Gray scale specification
 Gamma Value is approximately 2.2. For more information, see the Table 11.

Table 11. GRAY SCALE SPECIFICATION

Gray Level	Luminance [%] (Typ.)
L0	0.08
L15	0.32
L31	1.10
L47	2.60
L63	4.90
L79	8.10
L95	12.1
L111	16.7
L127	21.6
L143	28.0
L159	35.4
L175	43.9
L191	53.3
L207	64.1
L223	75.8
L239	88.0
L255	100

LC370WXE

Product Specification

Measuring point for surface luminance & measuring point for luminance variation.

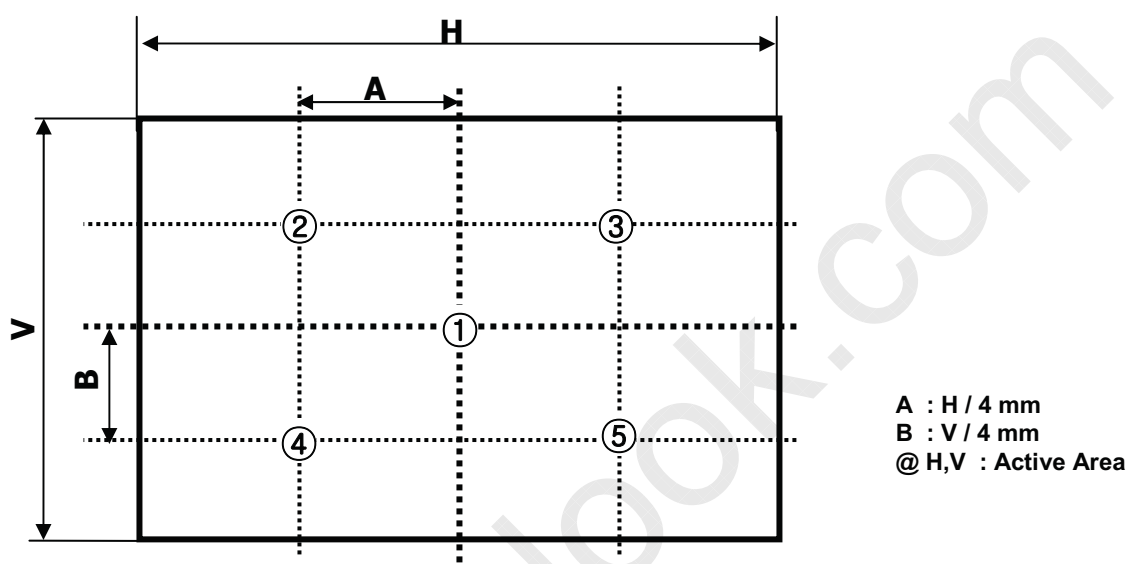

FIG. 2 5 Points for Luminance Measure

Response time is defined as the following figure and shall be measured by switching the input signal for "Gray(N)" and "Gray(M)".

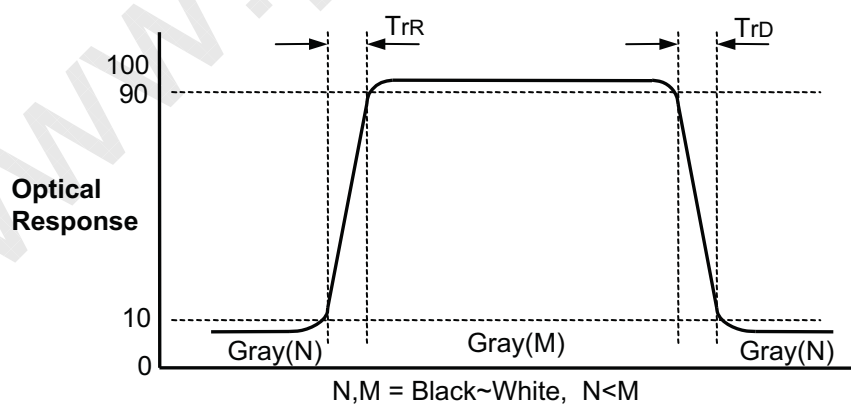

FIG. 3 Response Time

LC370WXE

Product Specification

Dimension of viewing angle range

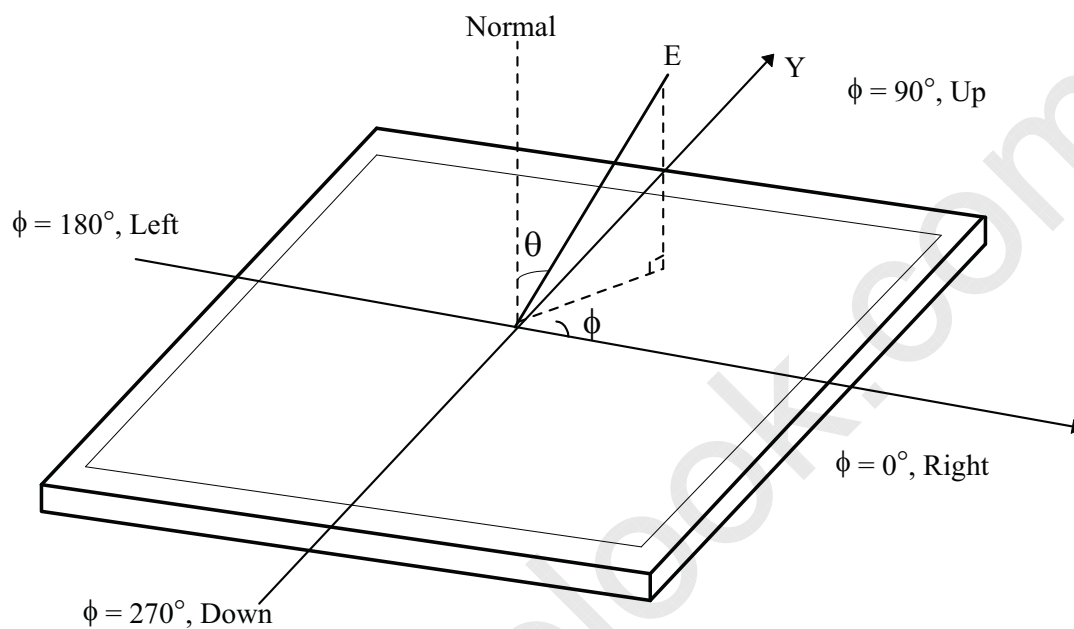

FIG. 4 Viewing Angle

LC370WXE

Product Specification

5. Mechanical Characteristics

Table 12 provides general mechanical characteristics.

Table 12. MECHANICAL CHARACTERISTICS

Item	Value	
Outline Dimension	Horizontal	877.0 mm
	Vertical	516.8 mm
	Depth	46.9 mm
Bezel Area	Horizontal	828.6mm
	Vertical	469.8mm
Active Display Area	Horizontal	819.6mm
	Vertical	460.8mm
Weight	7,500 g (Typ.) , 7,900 g (Max.)	

Note : Please refer to a mechanical drawing in terms of tolerance at the next page.

LC370WXE

Product Specification

<FRONT VIEW>

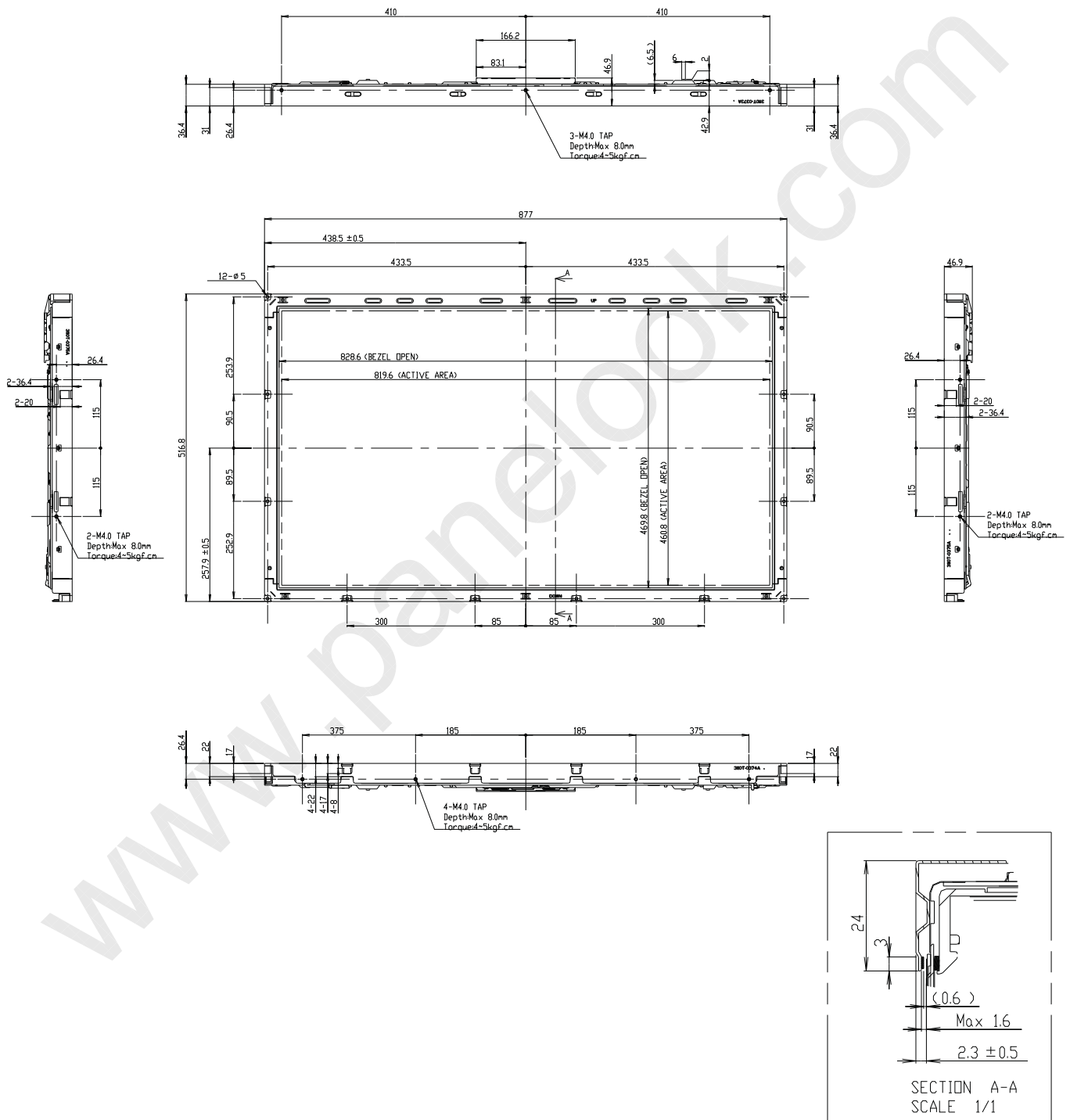

Ver. 0.1

21 / 39

LC370WXE

Product Specification

<REAR VIEW>

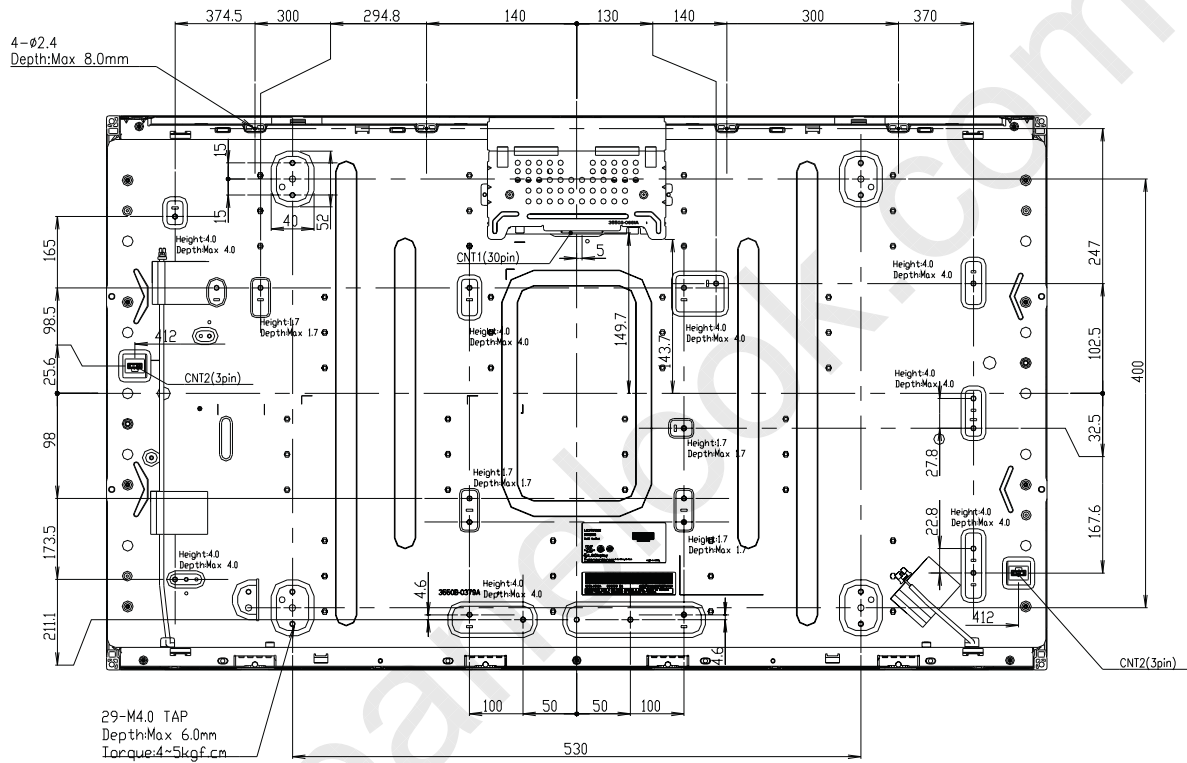

NOTES

1. Unspecified tolerances are to be $\pm 1.0\text{mm}$.
2. This drawing is only preliminary data and can be changed without notice.
3. Tilt and partial disposition tolerance of display area is as following.
 - (1) X-Direction : $|A-B| \leq 1.5\text{mm}$
 - (2) Y-Direction : $|C-D| \leq 1.5\text{mm}$

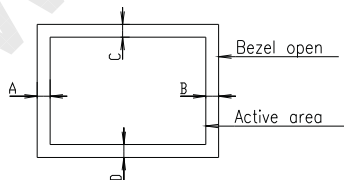

Ver. 0.1

22 / 39

Product Specification

6. Reliability**Table 14. ENVIRONMENT TEST CONDITION**

No.	Test Item	Condition
1	High temperature storage test	Ta= 60°C 240h
2	Low temperature storage test	Ta= -20°C 240h
3	High temperature operation test	Ta= 50°C 50%RH 240h
4	Low temperature operation test	Ta= 0°C 240h
5	Vibration test (non-operating)	Wave form : random Vibration level : 1.0Grms Bandwidth : 10-300Hz Duration : X,Y,Z, 10 min Each direction per 10 min.
6	Shock test (non-operating)	Shock level : 100Grms Waveform : half sine wave, 2ms Direction : ±X, ±Y, ±Z One time each direction
7	Humidity condition Operation	Ta= 40 °C ,90%RH
8	Altitude operating storage / shipment	0 - 15,000 ft 0 - 40,000 ft

Note : Before and after Reliability test, LCM should be operated with normal function.

Product Specification

7. International Standards

7-1. Safety

- a) UL 60065, 7th Edition, dated June 30, 2003, Underwriters Laboratories, Inc., Standard for Audio, Video and Similar Electronic Apparatus.
- b) CAN/CSA C22.2, No. 60065:03, Canadian Standards Association, Standard for Audio, Video and Similar Electronic Apparatus.
- c) IEC60065:2001, 7th Edition CB-scheme and EN 60065:2002, Safety requirements for Audio, Video and Similar Electronic Apparatus..

7-2. EMC

- a) ANSI C63.4 "Methods of Measurement of Radio-Noise Emissions from Low-Voltage Electrical and Electrical Equipment in the Range of 9kHz to 40GHz. "American National Standards Institute(ANSI), 1992
- b) CISPR13 "Limits and Methods of Measurement of Radio interference characteristics of Sound and Television broadcast receivers and associated equipment"
CISPR22 "Limits and Methods of Measurement of Radio interference characteristics of Information Technology Equipment" International Special Committee on Radio Interference.
- c) EN55013 "Limits and Methods of Measurement of Radio interference characteristics of Sound and Television broadcast receivers and associated equipment"
EN55022 "Limits and Methods of Measurement of Radio interference characteristics of Information Technology Equipment" European Committee for Electro Technical Standardization. (CENELEC), 1988(Including A1:2000)

LC370WXE

Product Specification

8. Packing**8-1. Designation of Lot Mark**

a) Lot Mark

A	B	C	D	E	F	G	H	I	J	K	L	M
---	---	---	---	---	---	---	---	---	---	---	---	---

A,B,C : SIZE(INCH)

E : MONTH

D : YEAR

F ~ M : SERIAL NO.

Note

1. YEAR

Year	2001	2002	2003	2004	2005	2006	2007	2008	2009	2010
Mark	1	2	3	4	5	6	7	8	9	0

2. MONTH

Month	Jan	Feb	Mar	Apr	May	Jun	Jul	Aug	Sep	Oct	Nov	Dec
Mark	1	2	3	4	5	6	7	8	9	A	B	C

b) Location of Lot Mark

Serial No. is printed on the label. The label is attached to the backside of the LCD module.
This is subject to change without prior notice.

8-2. Packing Form

a) Package quantity in one box : 4 pcs

b) Box Size : 968 mm X 366 mm X 595 mm.

Product Specification

9. Precautions

Please pay attention to the followings when you use this TFT LCD module.

9-1. Mounting Precautions

- (1) You must mount a module using specified mounting holes (Details refer to the drawings).
- (2) You should consider the mounting structure so that uneven force (ex. Twisted stress) is not applied to the module. And the case on which a module is mounted should have sufficient strength so that external force is not transmitted directly to the module.
- (3) Please attach the surface transparent protective plate to the surface in order to protect the polarizer. Transparent protective plate should have sufficient strength in order to resist external force.
- (4) You should adopt radiation structure to satisfy the temperature specification.
- (5) Acetic acid type and chlorine type materials for the cover case are not desirable because the former generates corrosive gas of attacking the polarizer at high temperature and the latter causes circuit break by electro-chemical reaction.
- (6) Do not touch, push or rub the exposed polarizers with glass, tweezers or anything harder than HB pencil lead. And please do not rub with dust clothes with chemical treatment. Do not touch the surface of polarizer for bare hand or greasy cloth. (Some cosmetics are detrimental to the polarizer.)
- (7) When the surface becomes dusty, please wipe gently with absorbent cotton or other soft materials like chamois soaks with petroleum benzene. Normal-hexane is recommended for cleaning the adhesives used to attach front / rear polarizers. Do not use acetone, toluene and alcohol because they cause chemical damage to the polarizer.
- (8) Wipe off saliva or water drops as soon as possible. Their long time contact with polarizer causes deformations and color fading.
- (9) Do not open the case because inside circuits do not have sufficient strength.

9-2. Operating Precautions

- (1) The spike noise causes the mis-operation of circuits. It should be lower than following voltage :
 $V = \pm 200\text{mV}$ (Over and under shoot voltage)
- (2) Response time depends on the temperature. (In lower temperature, it becomes longer.)
- (3) Brightness depends on the temperature. (In lower temperature, it becomes lower.)
And in lower temperature, response time (required time that brightness is stable after turned on) becomes longer
- (4) Be careful for condensation at sudden temperature change. Condensation makes damage to polarizer or electrical contacted parts. And after fading condensation, smear or spot will occur.
- (5) When fixed patterns are displayed for a long time, remnant image is likely to occur.
- (6) Module has high frequency circuits. Sufficient suppression to the electromagnetic interference shall be done by system manufacturers. Grounding and shielding methods may be important to minimize the interference.
- (7) Please do not give any mechanical and/or acoustical impact to LCM. Otherwise, LCM can't be operated its full characteristics perfectly.
- (8) A screw which is fastened up the steels should be a machine screw.
(if not, it can cause conductive particles and deal LCM a fatal blow)
- (9) Please do not set LCD on its edge.
- (10) Partial darkness may happen during 3~5 minutes when LCM is operated initially in condition that luminance is under 40% at low temperature (under 5°C). This phenomenon which disappears naturally after 3~5 minutes is not a problem about reliability but LCD characteristic

Product Specification

9-3. Electrostatic Discharge Control

Since a module is composed of electronic circuits, it is not strong to electrostatic discharge. Make certain that treatment persons are connected to ground through wrist band etc. And don't touch interface pin directly.

9-4. Precautions for Strong Light Exposure

Strong light exposure causes degradation of polarizer and color filter.

9-5. Storage

When storing modules as spares for a long time, the following precautions are necessary.

- (1) Store them in a dark place. Do not expose the module to sunlight or fluorescent light. Keep the temperature between 5°C and 35°C at normal humidity.
- (2) The polarizer surface should not come in contact with any other object.
It is recommended that they be stored in the container in which they were shipped.

9-6. Handling Precautions for Protection Film

- (1) The protection film is attached to the bezel with a small masking tape.
When the protection film is peeled off, static electricity is generated between the film and polarizer.
This should be peeled off slowly and carefully by people who are electrically grounded and with well ion-blown equipment or in such a condition, etc.
- (2) When the module with protection film attached is stored for a long time, sometimes there remains a very small amount of glue still on the bezel after the protection film is peeled off.
- (3) You can remove the glue easily. When the glue remains on the bezel surface or its vestige is recognized, please wipe them off with absorbent cotton waste or other soft material like chamois soaked with normal-hexane.

APPENDIX- I-1

■ Required signal assignment for Flat Link Transmitter (Pin9="L or NC")

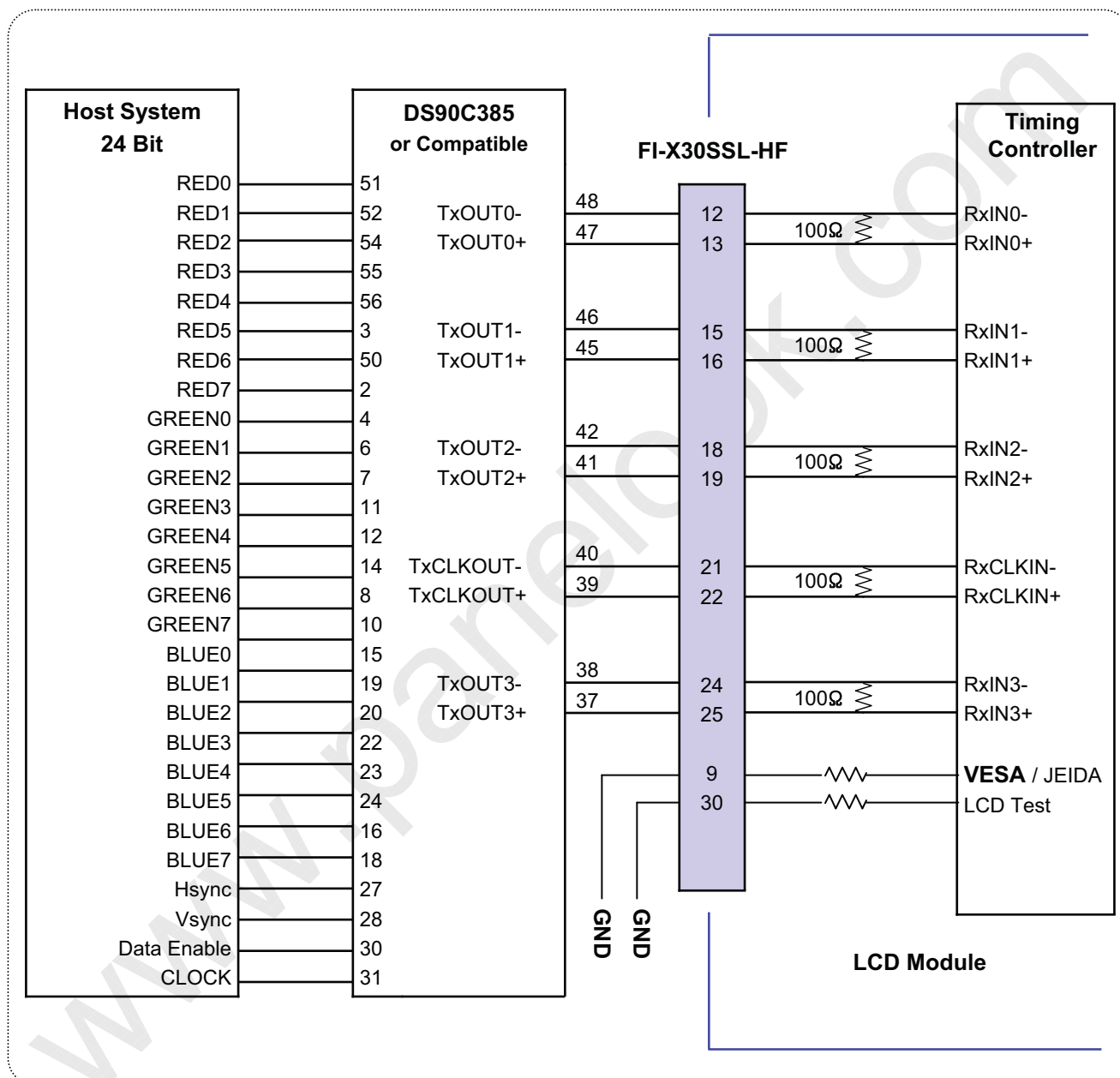

Notes:

1. The LCD module uses a 100 Ohm(Ω) resistor between positive and negative lines of each receiver input.
2. Refer to LVDS transmitter data sheet for detail descriptions. (DS90C385 or Compatible)
3. '7' means MSB and '0' means LSB at R,G,B pixel data.

APPENDIX- I-2

■ Required signal assignment for Flat Link Transmitter (Pin9="H")

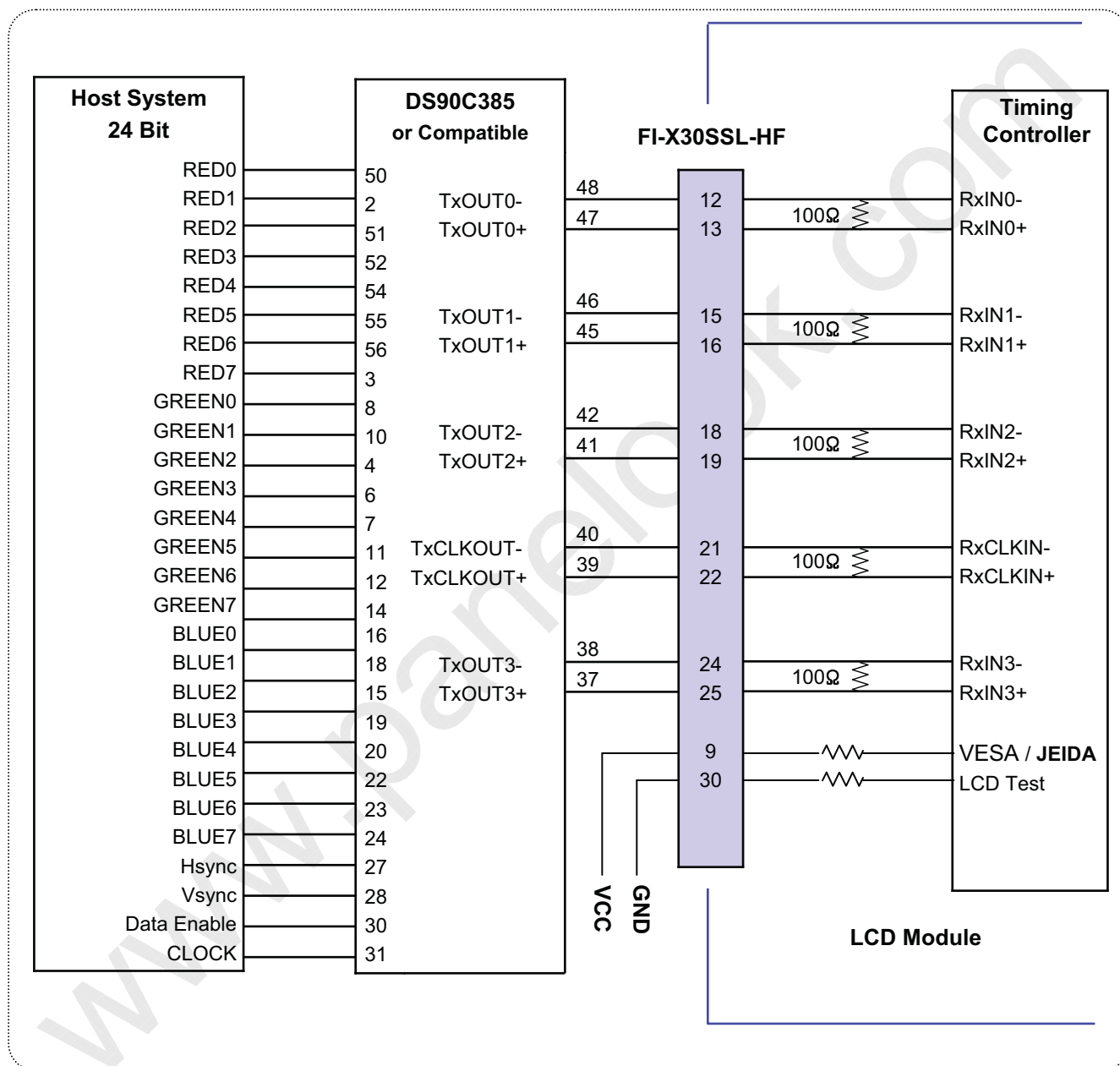

Notes:

1. The LCD module uses a 100 Ohm(Ω) resistor between positive and negative lines of each receiver input.
2. Refer to LVDS transmitter data sheet for detail descriptions. (DS90C385 or Compatible)
3. '7' means MSB and '0' means LSB at R,G,B pixel data.

LC370WXE

Product Specification

APPENDIX- II-1

■ Pallet Ass'y

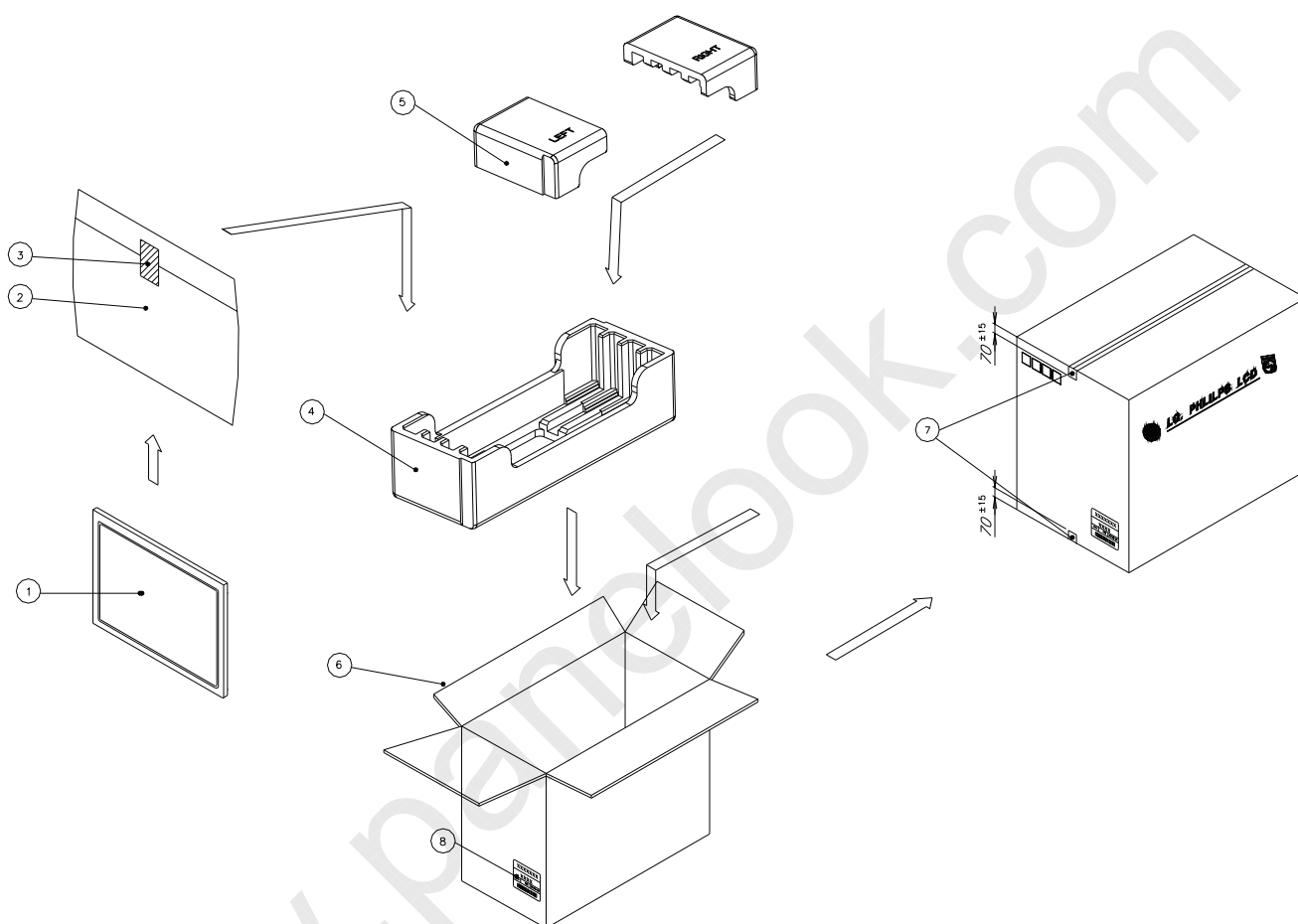

NO.	DESCRIPTION	MATERIAL
1	LCD Module	
2	BAG	AL
3	TAPE	MASKING 20MMX50M
4	Packing	EPS
5	Packing	EPS
6	BOX	PAPER_DW3
7	TAPE	OPP 70MMX300M
8	Label	ART 100X70

LC370WXE

Product Specification

APPENDIX- II-2

■ Pallet Ass'y

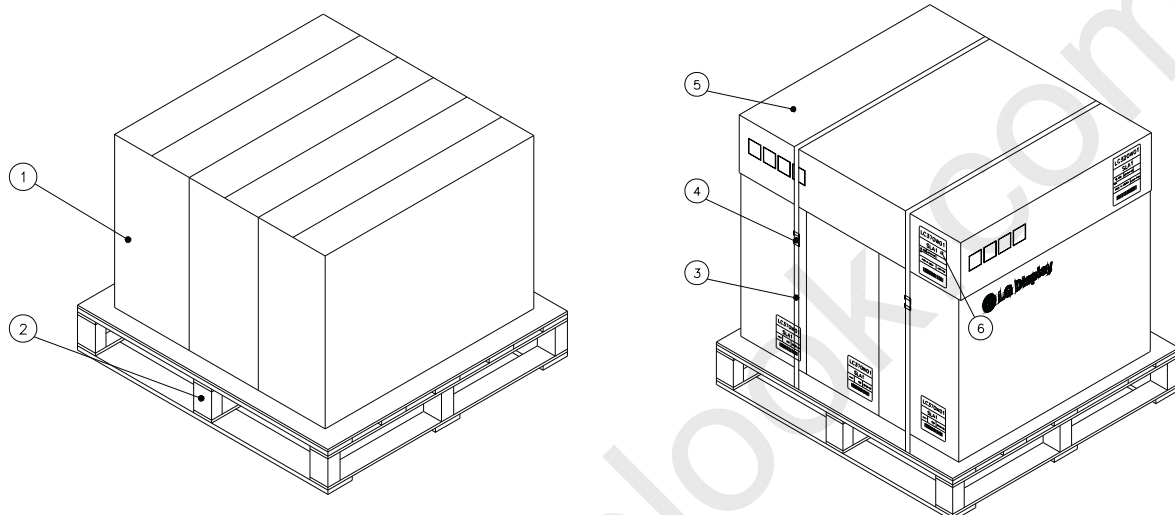

NO.	DESCRIPTION	MATERIAL
1	PACKING ASS'Y	
2	PALLET	Paper_1140X990X117.5
3	ANGLE, PACKING	SWR4
4	LABEL	YUPO PAPER
5	TAPE	OPP
6	BAND	PP
7	BAND, CLIP	CLIP 18MM

LC370WXE

APPENDIX- III

■ LCM Label

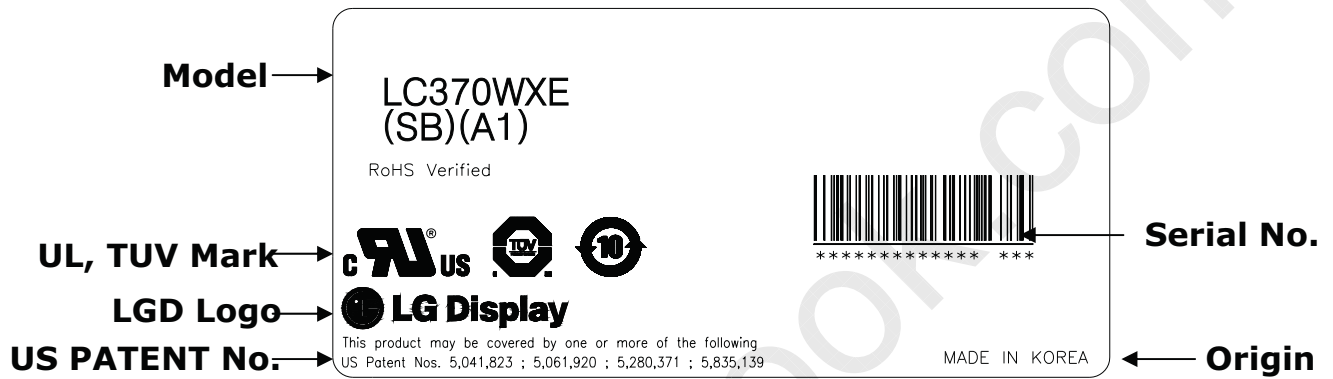

LC370WXE

APPENDIX- IV

■ Box Label and Pallet Label

■ Box Label

LC370WXE		
SBA1		
4 PCS	LOT/MM-DD	
MADE IN KOREA		RoHS Verified
 *****		

■ Pallet Label

LC370WXE		
SBA1		
12 PCS	LOT/MM-DD	
MADE IN KOREA		RoHS Verified
 *****		

APPENDIX- V

Option Pin Circuit Block Diagram

Circuit Block Diagram of LVDS Format Selection pin

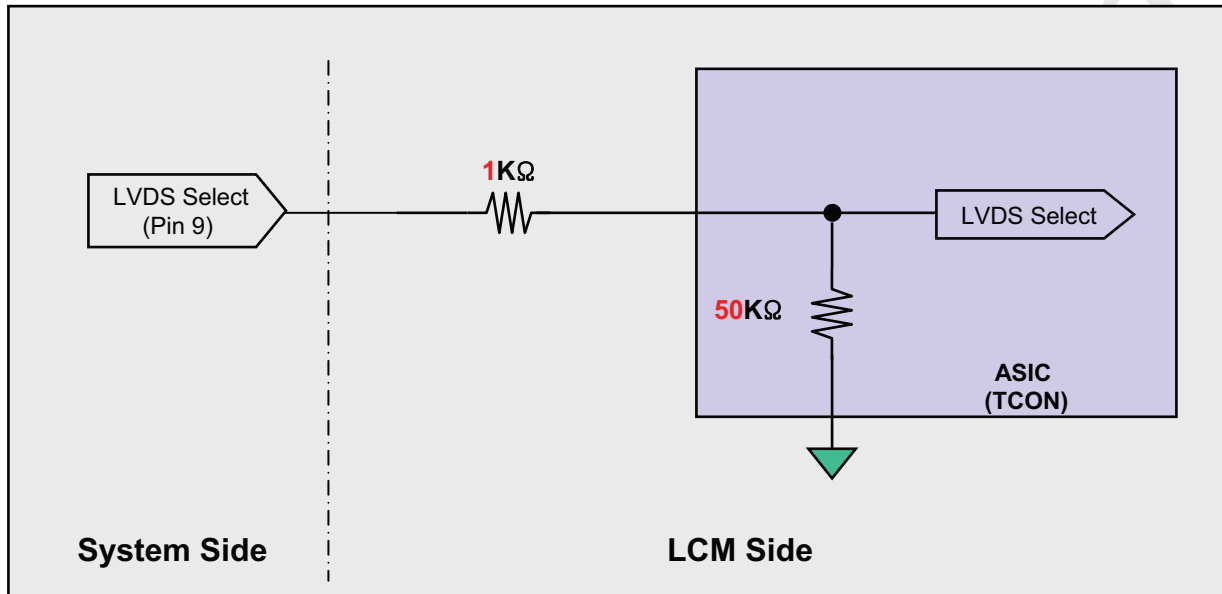

Product Specification

APPENDIX- VI-1

LVDS Input characteristics

1. DC Specification

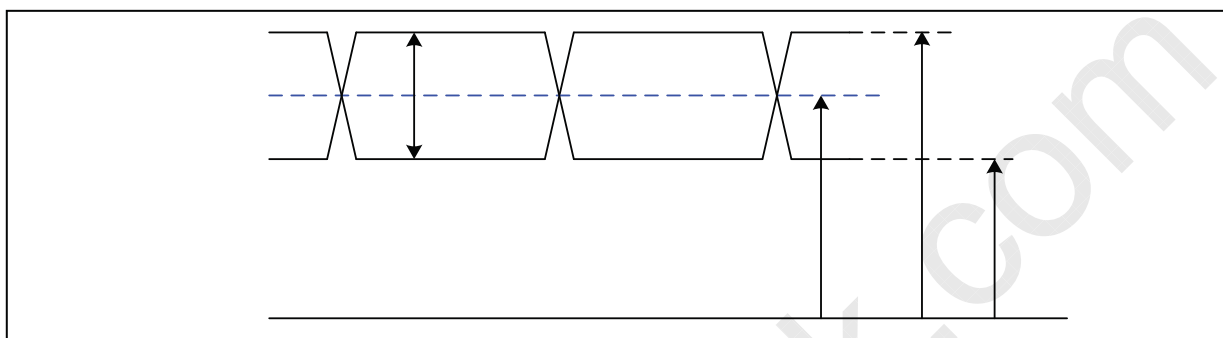

Description	Symbol	Min	Max	Unit	Notes
LVDS Single end Voltage	$ V_{ID} $	200	600	mV	-
LVDS Common mode Voltage	V_{CM}	1.0	1.5	V	-
LVDS Input Voltage Range	V_{IN}	0.7	1.8	V	-
Change in common mode Voltage	ΔV_{CM}		250	mV	-

2. AC Specification

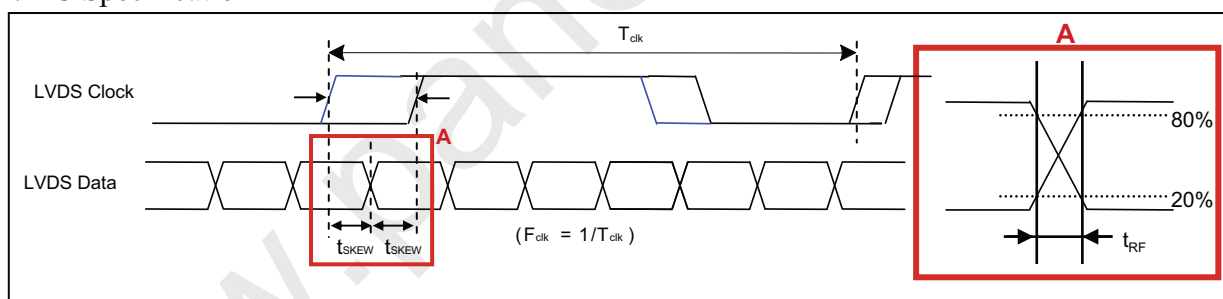

Description	Symbol	Min	Max	Unit	Notes
LVDS Clock to Data Skew Margin	t_{SKEW}		$(0.25 * T_{clk})/7$	ps	-
LVDS Clock/DATA Rising/Falling time	t_{RF}	260	$(0.3 * T_{clk})/7$	ps	2
Effective time of LVDS	t_{eff}	± 350		ps	LVDS -

Notes : 1. All Input levels of LVDS signals are based on the EIA 644 Standard.

2. If t_{RF} isn't enough, t_{eff} should meet the range.

LC370WXE

Product Specification

APPENDIX- VI-2

LVDS Input characteristics

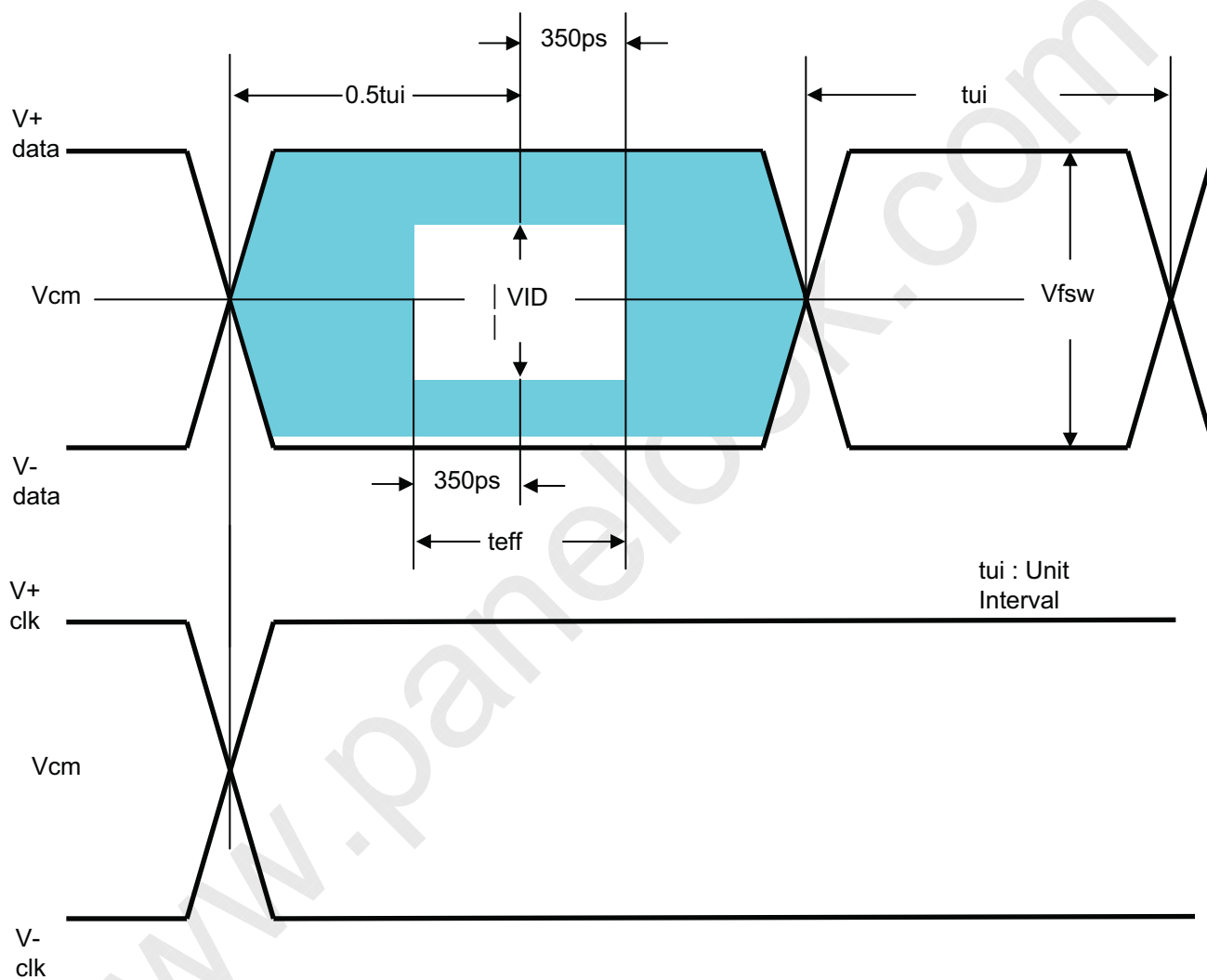

APPENDIX- VII

LVDS Data-Mapping info. (8bit)

■ LVDS Select : "H" Data-Mapping (JEIDA format)

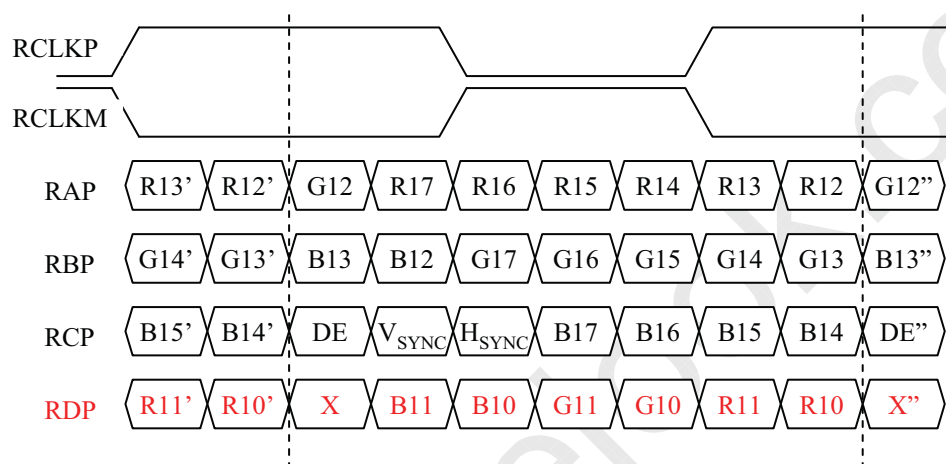

■ LVDS Select : "L" Data-Mapping (VESA format)

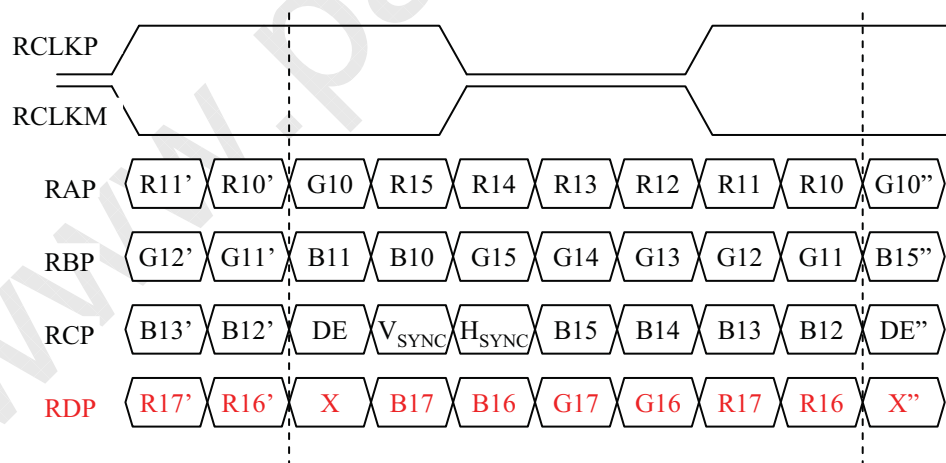

Product Specification

APPENDIX- VIII

Gray to Gray Response Time Uniformity

This is only the reference data of G to G and uniformity for LC370WXE-SBA1 model.

1. G to G Response Time :

Response time is defined as Figure3 and shall be measured by switching the input signal for "Gray (N) " and "Gray(M)".(32Gray Step at 8bit)

2. G to G Uniformity

The variation of G to G Uniformity , $\delta_{G \text{ to } G}$ is defined as :

$$G \text{ to } G \text{ Uniformity} = \frac{\text{Maximum}(GtoG) - \text{Typical}(GtoG)}{\text{Typical}(GtoG)} \leq 1$$

*Maximum (GtoG) means maximum value of measured time (N, M = 0 (Black) ~ 255(White), 32 gray step).

	0Gray	32Gray	64Gray	...	223Gray	255Gray
0Gray		TrR:0G→32G	TrR:0G→64G	...	TrR:0G→223G	TrR:0G→255G
32Gray	TrD:32G→0G		TrR:32G→64G	...	TrR:32G→223G	TrR:32G→255G
64Gray	TrD:64G→0G	TrD:64G→32G		...	TrR:64G→223G	TrR:64G→255G
...
223Gray	TrD:223G→0G	TrD:223G→32G	TrD:223G→64G	...		TrR:223G→255G
255Gray	TrD:255G→0G	TrD:255G→32G	TrD:255G→64G	...	TrD:255G→223G	

3. Sampling Size : 2 pcs

4. Measurement Method : Follow the same rule as optical characteristics measurement.

5. Current Status

Below table is actual data of production on SEP. ?, 2008 (LGD RV Event Sample)

	G to G Response Time [ms]		Uniformity
	Min.	Max.	
# 1	2.8	7.0	0.40
# 2	3.0	7.6	0.52

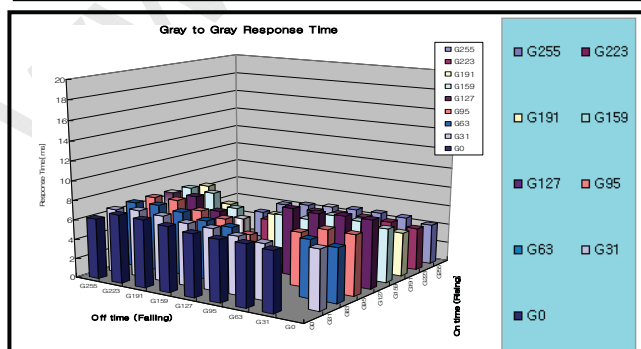

< # 1 >

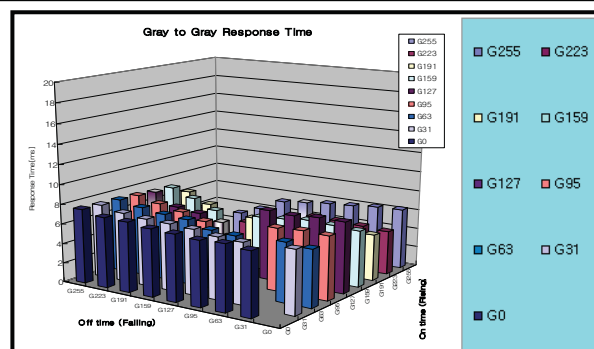

< # 2 >

LC370WXE

Product Specification

APPENDIX- IX

■ Lamp Electrical spec

	Item	Unit	Standards		Notes
			Frequency	Characteristics	
1	Lamp Voltage V_L	V_{rms}	63kHz	$1,530 \pm 10\%$ IL=3.0mA (25°C) $1,950 \pm 10\%$ IL=7.0mA (25°C) $2,020 \pm 10\%$ IL=7.5mA (25°C) $2,100 \pm 10\%$ IL=8.0mA (25°C)	1, 3
2	Lamp Current I_L	mA_{rms}		Min 3.0 Typ 7.0 Max 8.0	1, 3
3	Lamp power $V_L \times I_L$	W	63kHz	3.0 IL=3.0mA 8.6 IL=7.0mA 9.1 IL=7.5mA 9.6 IL=8.0mA	1, 3
4	Starting Voltage	V_{rms}	63kHz	MAX 2,300 (0°C) MAX 1,920 (25°C)	2
5	Discharge Stabilization Time	min		3	3, 4
6	Operating Frequency	kHz		40~63(Typ)~80	5

- Note
- 1) Started at IL=7.0(mA) and measure 3 minutes later.
 - 2) Voltage at switch on. Inverter output voltage.
 - 3) Ambient Temperature should be $25 \pm 1^\circ\text{C}$ under no wind.
 - 4) The time needed to achieve not less than 95% luminance of the center / center part of lamp. The center / center part of lamp shall be measured. The luminance of the lamp after lighted for 5minutes is defined as 100%.
 - 5) The frequency range can be keep within $\pm 10\%$ range of optical characteristics. (except the chromaticity)