

SPECIFICATION FOR APPROVAL

- (●) Preliminary Specification
() Final Specification

Title	42.0" WUXGA TFT LCD
--------------	----------------------------

BUYER	KONKA
MODEL	

SUPPLIER	LG.Display Co., Ltd.
*MODEL	LC420DUJ
SUFFIX	SGK1 (RoHS Verified)

*When you obtain standard approval,
please use the above model name without suffix

APPROVED BY	SIGNATURE DATE
/	
/	
/	

Please return 1 copy for your confirmation with
your signature and comments.

APPROVED BY	SIGNATURE DATE
Y.J. Heo / Team Leader	
REVIEWED BY	
Q.H. Joe / Project Leader	
PREPARED BY	
M.S. Park / Engineer	

TV Products Development Dept.
LG. Display LCD Co., Ltd

Product Specification

CONTENTS

Number	ITEM	Page
	COVER	0
	CONTENTS	1
	RECORD OF REVISIONS	2
1	GENERAL DESCRIPTION	3
2	ABSOLUTE MAXIMUM RATINGS	4
3	ELECTRICAL SPECIFICATIONS	5
3-1	ELECTRICAL CHARACTERISTICS	5
3-2	INTERFACE CONNECTIONS	6
3-3	SIGNAL TIMING SPECIFICATIONS	7
3-4	LVDS SIGNAL SPECIFICATIONS	9
3-5	INTARA INTERFACE SIGNAL SPECIFICATION	12
3-6	COLOR DATA REFERENCE	13
3-7	POWER SEQUENCE	14
4	OPTICAL SPECIFICATIONS	15
5	MECHANICAL CHARACTERISTICS	21
6	MECHANICAL DIMENSION	22
6-1	BOARD ASSEMBLY DIMENSION	22
6-2	CONTROL BOARD ASSEMBLY DIMMENSION	23
7	RELIABILITY	24
8	INTERNATIONAL STANDARDS	25
8-1	SAFETY	25
8-2	ENVIRONMENT	25
9	PACKING	26
9-1	PACKING FORM	26
10	PRECAUTIONS	27
10-1	HANDLING PRECAUTIONS	27
10-2	OPERATING PRECAUTIONS	27
10-3	PROTECTION FILM	28
10-4	STORAGE PRECAUTIONS	28
10-5	PACKING PRECAUTIONS	28
10-6	OPERATING CONDITION GUIDE	28

Product Specification

1. General Description

The LC420DUJ is a Color Active Matrix Liquid Crystal Display with an integral the Source PCB and Gate implanted on Panel (GIP). The matrix employs a-Si Thin Film Transistor as the active element. It is a transmissive type display operating in the normally black mode. It has a 41.92 inch diagonally measured active display area with WUXGA resolution (1080 vertical by 1920 horizontal pixel array). Each pixel is divided into Red, Green and Blue sub-pixels or dots which are arranged in vertical stripes. Gray scale or the luminance of the sub-pixel color is determined with a 8-bit gray scale signal for each dot. Therefore, it can present a palette of more than 16.7M(true) colors.

It is intended to support LCD TV, PCTV where high brightness, super wide viewing angle, high color gamut, high color depth and fast response time are important.

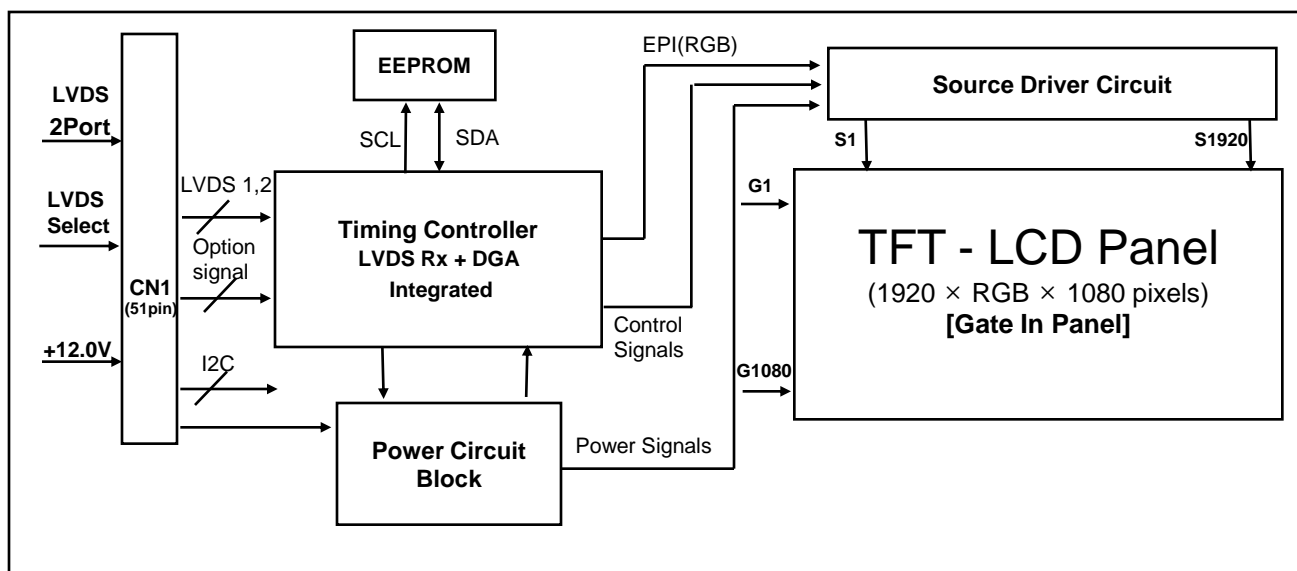

General Features

Active Screen Size	41.92inches(1064.77mm) diagonal
Outline Dimension	943.6(H) x 538.3 (V) x 1.4 mm(D) (Typ.)
Pixel Pitch	0.4833 mm x 0.4833 mm
Pixel Format	1920 horiz. by 1080 vert. Pixels, RGB stripe arrangement
Color Depth	8-bit, 16.7 M colors
Drive IC Data Interface	Source D-IC : 8-bit EPI, gamma reference voltage, and control signals Gate D-IC : Gate In Panel
Transmittance (With POL)	6.25%(Typ.)
Viewing Angle (CR>10)	Viewing angle free (R/L 178 (Min.), U/D 178 (Min.))
Weight	1.5Kg (Typ.)
Display Mode	Transmissive mode, Normally black
Surface Treatment (Top)	Hard coating(2H), Anti-glare treatment of the front polarizer, Haze 1%(Typ.)

Product Specification

2. Absolute Maximum Ratings

The following items are maximum values which, if exceeded, may cause faulty operation or permanent damage to the LCD module.

Table 1. ABSOLUTE MAXIMUM RATINGS

Parameter		Symbol	Value		Unit	Note
			Min	Max		
Power Input Voltage	LCD Circuit	V _{LCD}	-0.3	+14.0	V _{DC}	1
T-Con Option Selection Voltage		V _{LOGIC}	-0.3	+4.0	V _{DC}	
Operating Temperature		T _{OP}	0	+50	°C	2,3
Storage Temperature(without packing)		T _{ST}	-20	+60	°C	
Panel Front Temperature		T _{SUR}	-	+68	°C	4
Operating Ambient Humidity		H _{OP}	10	90	%RH	2,3
Storage Humidity		H _{ST}	5	90	%RH	

Note1. Ambient temperature condition ($T_a = 25 \pm 2 \text{ }^\circ\text{C}$)

2. Temperature and relative humidity range are shown in the figure below.

Wet bulb temperature should be Max 39°C, and no condensation of water.

3. Gravity mura can be guaranteed below 40°C condition.

4. The maximum operating temperatures is based on the test condition that the surface temperature of display area is less than or equal to 68°C with LCD module alone in a temperature controlled chamber. Thermal management should be considered in final product design to prevent the surface temperature of display area from being over 68°C. The range of operating temperature may be degraded in case of improper thermal management in final product design.

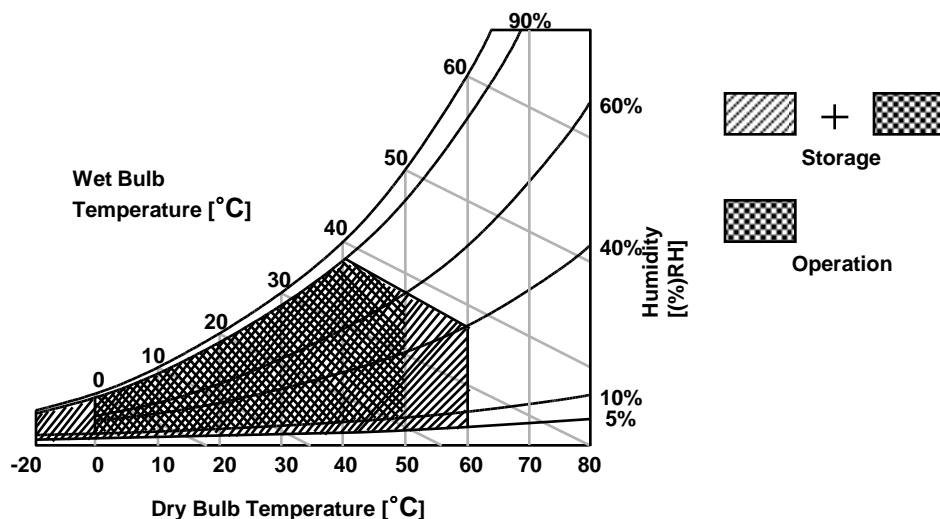

Product Specification

3. Electrical Specifications

3-1. Electrical Characteristics

Table 2. ELECTRICAL CHARACTERISTICS

Parameter		Symbol	Value			Unit	Note
			Min	Typ	Max		
Circuit :							
Power Input Voltage		V _{LCD}	10.8	12.0	13.2	VDC	
Power Input Current		I _{LCD}	-	500	650	mA	1
			-	700	910	mA	2
T-CON Option Selection Voltage	Input High Voltage	V _{IH}	1.62	-	1.98	VDC	
	Input Low Voltage	V _{IL}	0	-	0.54	VDC	
Power Consumption		P _{LCD}	-	6	7.8	Watt	1
Rush current		I _{RUSH}	-	-	5.0	A	3

- Note 1. The specified current and power consumption are under the $V_{LCD}=12.0V$, $T_a=25 \pm 2^\circ C$, $f_v=60Hz$ condition, and mosaic pattern(8 x 6) is displayed and f_v is the frame frequency.
2. The current is specified at the maximum current pattern.
3. The duration of rush current is about 2ms and rising time of power input is 0.5ms (min.).
4. Ripple voltage level is recommended under $\pm 5\%$ of typical voltage

White : 255 Gray
Black : 0 Gray

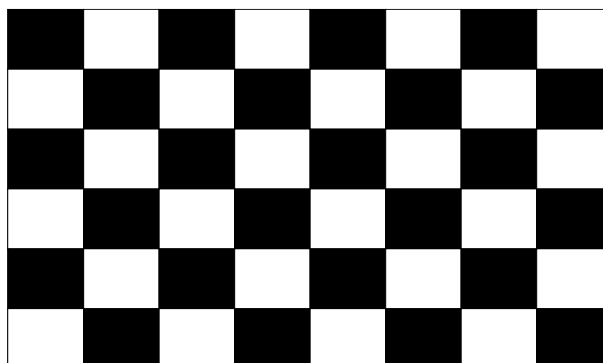

Mosaic Pattern(8 x 6)

Product Specification

3-2. Interface Connections

This LCD module employs two kinds of interface connection, 51-pin connector is used for the module electronics.

3-2-1. LCD Module

- LCD Connector(CN1): FI-RE51S-HF(manufactured by JAE) or GT05P-51S-H38(manufactured by LSM) or IS050-C51B-C39(manufactured by UJU)
- Mating Connector : FI-R51HL(JAE) or compatible

Table 3. MODULE CONNECTOR(CN1) PIN CONFIGURATION

No	Symbol	Description	No	Symbol	Description
1	NC	No Connection (Note 4)	27	NC	No connection
2	NC	No Connection (Note 4)	28	R2AN	SECOND LVDS Receiver Signal (A-)
3	NC	No Connection (Note 4)	29	R2AP	SECOND LVDS Receiver Signal (A+)
4	NC	No Connection (Note 4)	30	R2BN	SECOND LVDS Receiver Signal (B-)
5	NC	No Connection (Note 4)	31	R2BP	SECOND LVDS Receiver Signal (B+)
6	NC	No Connection (Note 4)	32	R2CN	SECOND LVDS Receiver Signal (C-)
7	LVDS Select	'H' =JEIDA , 'L' or NC = VESA	33	R2CP	SECOND LVDS Receiver Signal (C+)
8	NC	No Connection (Note 4)	34	GND	Ground
9	NC	No Connection (Note 4)	35	R2CLKN	SECOND LVDS Receiver Clock Signal(-)
10	NC	No Connection (Note 4)	36	R2CLKP	SECOND LVDS Receiver Clock Signal(+)
11	GND	Ground	37	GND	Ground
12	R1AN	FIRST LVDS Receiver Signal (A-)	38	R2DN	SECOND LVDS Receiver Signal (D-)
13	R1AP	FIRST LVDS Receiver Signal (A+)	39	R2DP	SECOND LVDS Receiver Signal (D+)
14	R1BN	FIRST LVDS Receiver Signal (B-)	40	NC	No connection
15	R1BP	FIRST LVDS Receiver Signal (B+)	41	NC	No connection
16	R1CN	FIRST LVDS Receiver Signal (C-)	42	NC or GND	No Connection or Ground
17	R1CP	FIRST LVDS Receiver Signal (C+)	43	NC or GND	No Connection or Ground
18	GND	Ground	44	GND	Ground (Note 5)
19	R1CLKN	FIRST LVDS Receiver Clock Signal(-)	45	GND	Ground
20	R1CLKP	FIRST LVDS Receiver Clock Signal(+)	46	GND	Ground
21	GND	Ground	47	NC	No connection
22	R1DN	FIRST LVDS Receiver Signal (D-)	48	VLCD	Power Supply +12.0V
23	R1DP	FIRST LVDS Receiver Signal (D+)	49	VLCD	Power Supply +12.0V
24	NC	No connection	50	VLCD	Power Supply +12.0V
25	NC	No connection	51	VLCD	Power Supply +12.0V
26	NC or GND	No Connection or Ground	-	-	-

- Note
1. All GND(ground) pins should be connected together to the LCD module's metal frame.
 2. All VLCD (power input) pins should be connected together.
 3. All Input levels of LVDS signals are based on the **EIA 644** Standard.
 4. #1~#6 & #8~#10 NC (No Connection): These pins are used only for LGD (Do not connect)
 5. Specific pin No. **#44** is used for "No signal detection" of system signal interface.
It should be GND for NSB(No Signal Black) during the system interface signal is not.
If this pin is "H", LCD Module displays AGP(Auto Generation Pattern).

Product Specification

3-3. Signal Timing Specifications

Table 4 shows the signal timing required at the input of the LVDS transmitter. All of the interface signal timings should be satisfied with the following specification for normal operation.

Table 4. TIMING TABLE for NTSC & PAL(DE Only Mode)

ITEM		Symbol	Min	Typ	Max	Unit	notes
Horizontal	Display Period	tHV	960	960	960	tCLK	1920 / 2
	Blank	tHB	100	140	240	tCLK	1
	Total	tHP	1060	1100	1200	tCLK	
Vertical	Display Period	tVv	1080	1080	1080	Lines	
	Blank	tVB	20	45	300	Lines	1
	Total	tVP	1100	1125	1380	Lines	

ITEM		Symbol	Min	Typ	Max	Unit	notes
Frequency	DCLK	fCLK	60.00	74.25	78.00	MHz	
	Horizontal	fH	57.3	67.5	70	KHz	2
	Vertical	fV	47	60	63	Hz	2

notes: 1. The input of HSYNC & VSYNC signal does not have an effect on normal operation (DE Only Mode).
If you use spread spectrum of EMI, add some additional clock to minimum value for clock margin.

2. The performance of the electro-optical characteristics may be influenced by variance of the vertical refresh rate and the horizontal frequency

3. Spread Spectrum Rate (SSR) for 50KHz ~ 100KHz Modulation Frequency(FMOD) is calculated by $(7 - 0.06 * F_{mod})$, where Modulation Frequency (FMOD) unit is KHz.
LVDS Receiver Spread spectrum Clock is defined as below figure

※ Timing should be set based on clock frequency.

Product Specification

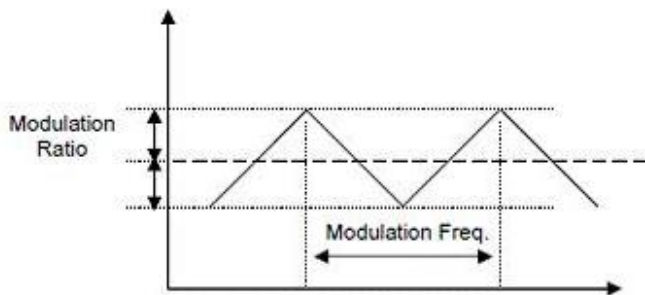
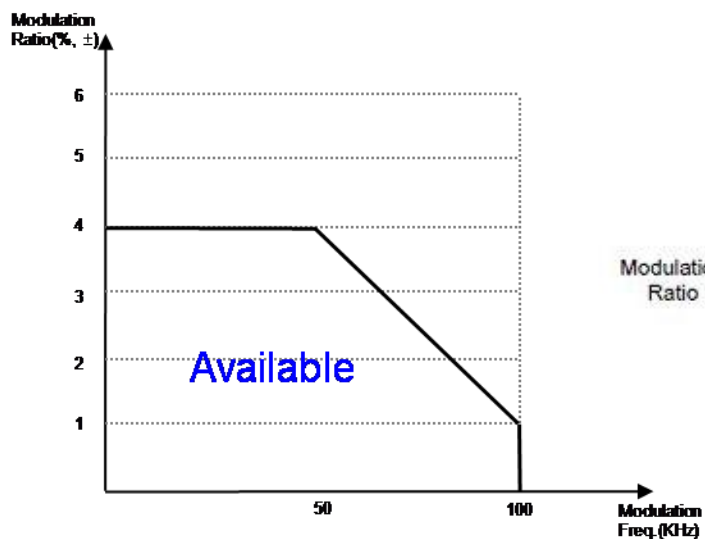

※ Please pay attention to the followings when you set Spread Spectrum Rate(SSR) and Modulation Frequency(FMOD)

1. Please set proper Spread Spectrum Rate(SSR) and Modulation Frequency (FMOD) of TV system LVDS output.
2. Please check FOS after you set Spread Spectrum Rate(SSR) and Modulation Frequency(FMOD) to avoid abnormal display. Especially, harmonic noise can appear when you use Spread Spectrum under FMOD 30 KHz.

Product Specification

3-4. LVDS Signal Specification

3-4-1. LVDS Input Signal Timing Diagram

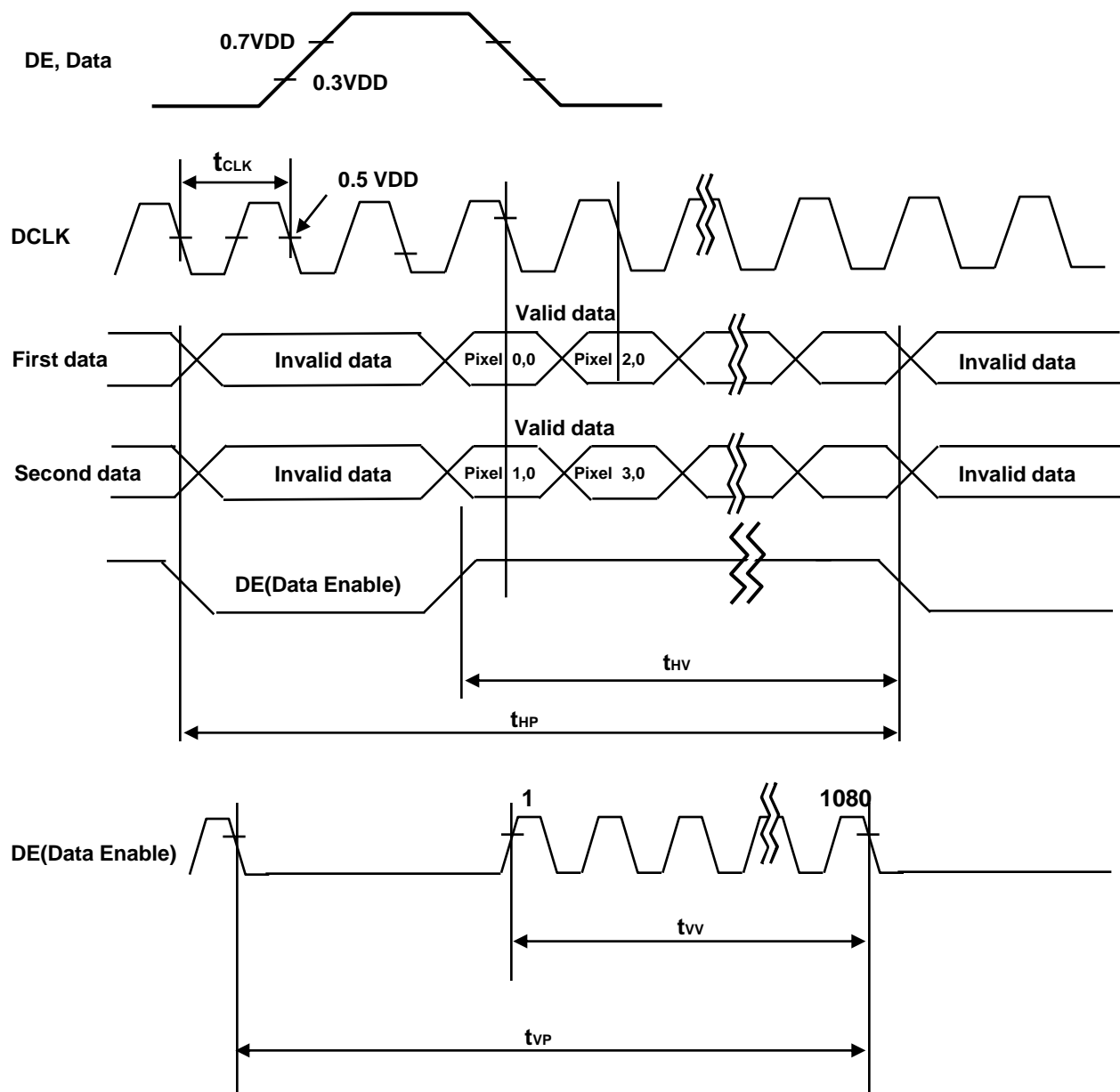

Product Specification

3-4-2. LVDS Input Signal Characteristics

1) DC Specification

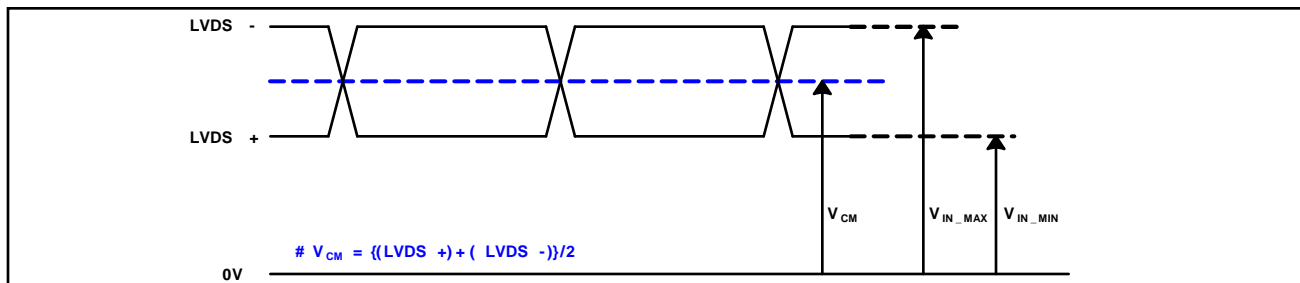

Description	Symbol	Min	Max	Unit	notes
LVDS Common mode Voltage	V_{CM}	1.0	1.5	V	-
LVDS Input Voltage Range	V_{IN}	0.7	1.8	V	-
Change in common mode Voltage	ΔV_{CM}	-	250	mV	-

2) AC Specification

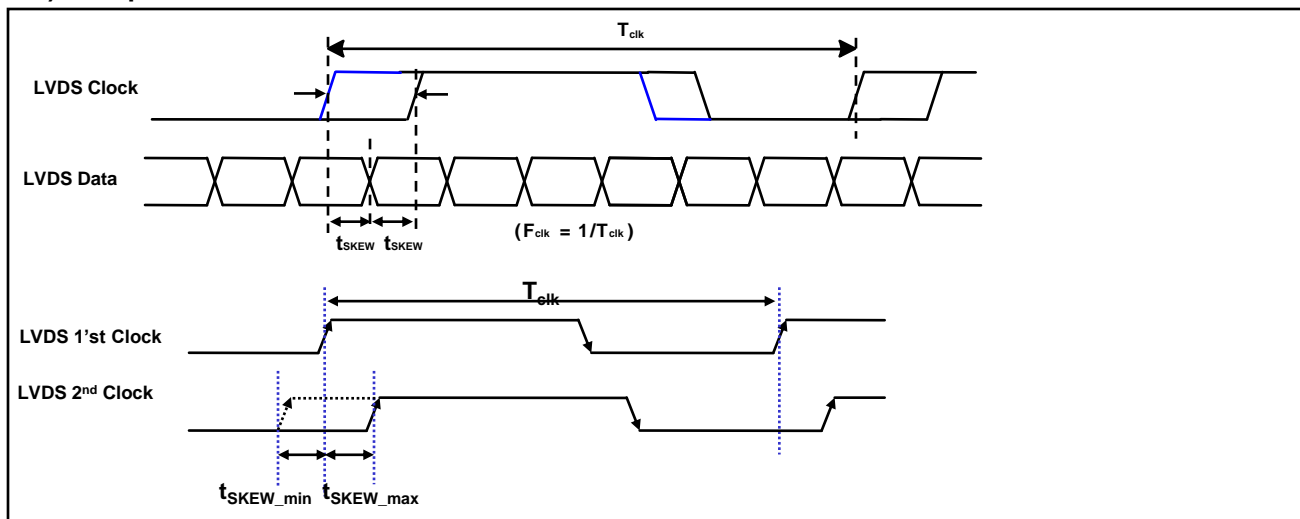

Description	Symbol	Min	Max	Unit	notes
LVDS Differential Voltage	V_{TH}	100	600	mV	Tested with Differential Probe 2
	V_{TL}	-600	-100	mV	
LVDS Clock to Data Skew	t_{SKEW}	-	$ (0.25 * T_{clk})/7 $	ps	-
Effective time of LVDS	t_{eff}	$ \pm 360 $	-	ps	-
LVDS Clock to Clock Skew (Even to Odd)	t_{SKEW_EO}	-	$ 1/7 * T_{clk} $	ps	-

notes 1. All Input levels of LVDS signals are based on the EIA 644 Standard.

2. If t_{RF} isn't enough, t_{eff} should be meet the range.

3. LVDS Differential Voltage is defined within t_{eff}

Product Specification

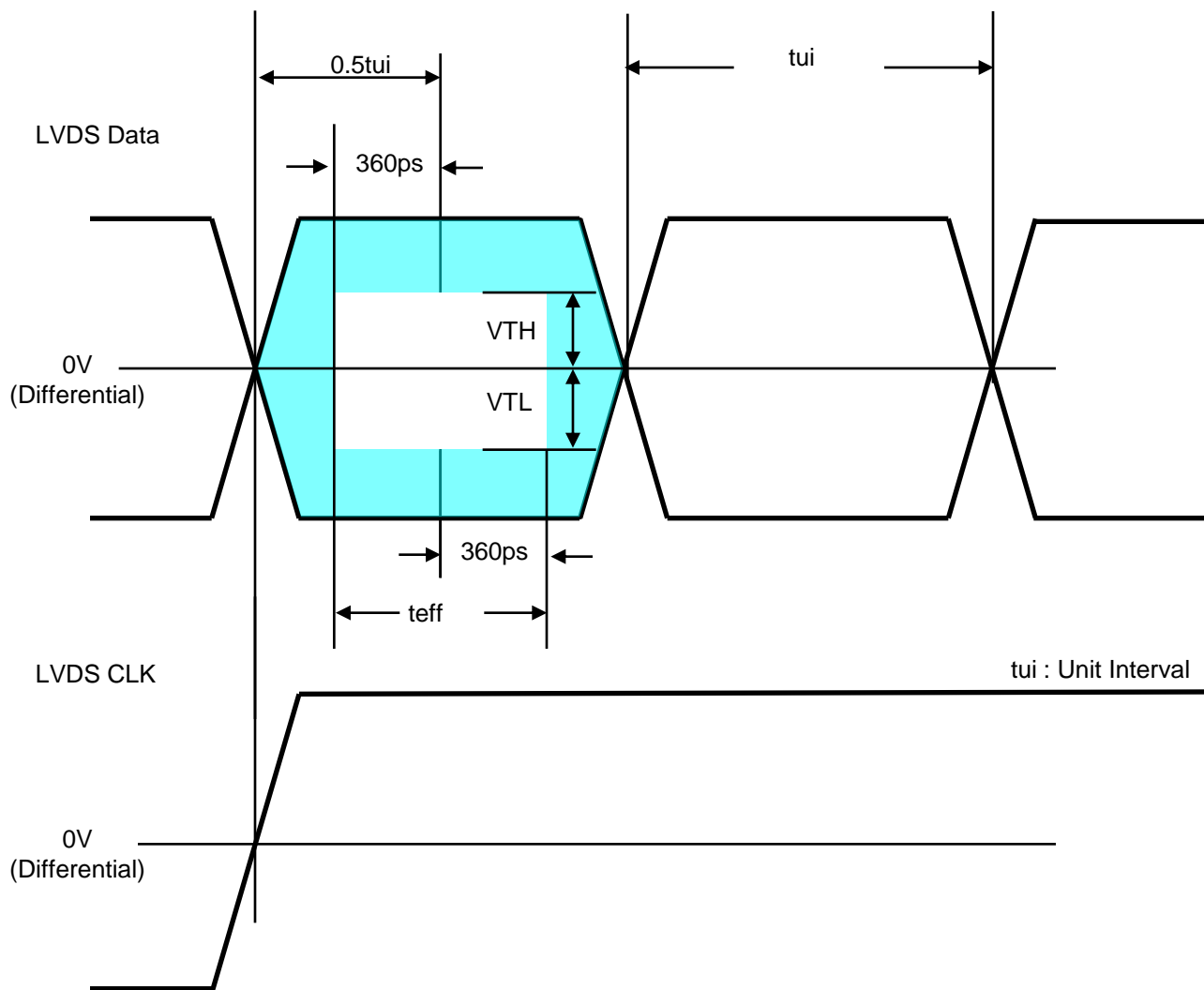

* This accumulated waveform is tested with differential probe

Product Specification

3-5. Intra interface Signal Specification

3-5-1. EPI Signal Specification

Table 5. ELECTRICAL CHARACTERISTICS

Parameter	Symbol	Condition	MIN	TYP	MAX	Unit	notes
Logic & EPI Power Voltage	VCC	-	1.62	1.8	1.98	V _{DC}	
EPI input common voltage	VCM	LVDS Type	0.8	VCC/2	1.3	V	
EPI input differential voltage	V _{diff}	-	150	-	500	mV	
EPI Input eye diagram	V _{eye}	-	90	-	-	mV	
Effective Veye width time	B1&B2		0.25	-	-	UI	

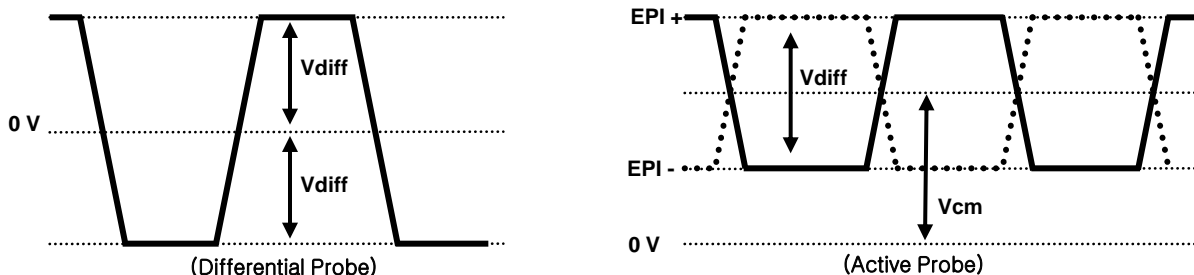

EPI Differential signal characteristics

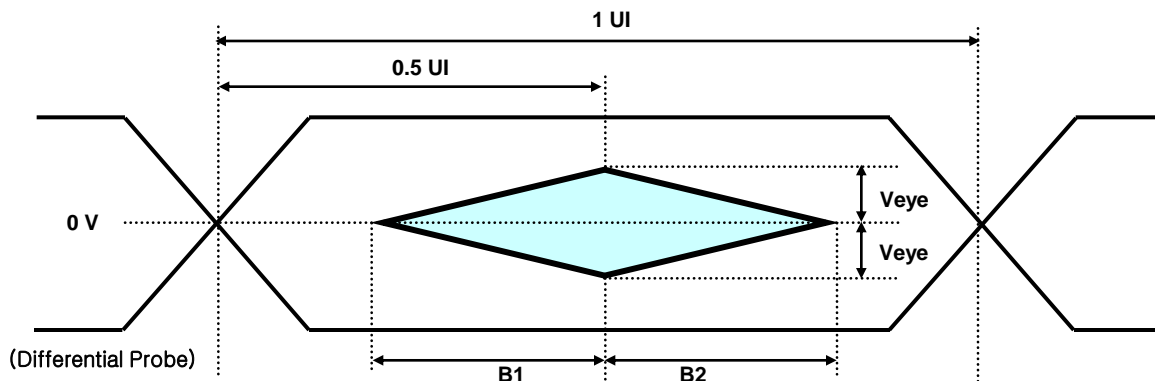

Eye Pattern of EPI Input

*Source PCB

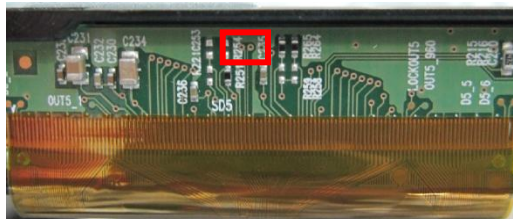

FIG. 3 Measure point

Product Specification

3-6. Color Data Reference

The brightness of each primary color(red,green,blue) is based on the 8bit gray scale data input for the color. The higher binary input, the brighter the color. Table 6 provides a reference for color versus data input.

Table 6. COLOR DATA REFERENCE

Color		Input Color Data																							
		RED								GREEN								BLUE							
		MSB							LSB	MSB							LSB	MSB							LSB
		R7	R6	R5	R4	R3	R2	R1	R0	G7	G6	G5	G4	G3	G2	G1	G0	B7	B6	B5	B4	B3	B2	B1	B0
Basic Color	Black	0	0	0	0	0	0	0	0	0	0	0	0	0	0	0	0	0	0	0	0	0	0	0	0
	Red (255)	1	1	1	1	1	1	1	1	0	0	0	0	0	0	0	0	0	0	0	0	0	0	0	0
	Green (255)	0	0	0	0	0	0	0	0	1	1	1	1	1	1	1	1	0	0	0	0	0	0	0	0
	Blue (255)	0	0	0	0	0	0	0	0	0	0	0	0	0	0	0	0	1	1	1	1	1	1	1	1
	Cyan	0	0	0	0	0	0	0	0	1	1	1	1	1	1	1	1	1	1	1	1	1	1	1	1
	Magenta	1	1	1	1	1	1	1	1	0	0	0	0	0	0	0	0	1	1	1	1	1	1	1	1
	Yellow	1	1	1	1	1	1	1	1	1	1	1	1	1	1	1	1	0	0	0	0	0	0	0	0
	White	1	1	1	1	1	1	1	1	1	1	1	1	1	1	1	1	1	1	1	1	1	1	1	1
RED	RED (000)	0	0	0	0	0	0	0	0	0	0	0	0	0	0	0	0	0	0	0	0	0	0	0	0
	RED (001)	0	0	0	0	0	0	0	1	0	0	0	0	0	0	0	0	0	0	0	0	0	0	0	0
							
	RED (254)	1	1	1	1	1	1	1	0	0	0	0	0	0	0	0	0	0	0	0	0	0	0	0	0
	RED (255)	1	1	1	1	1	1	1	1	0	0	0	0	0	0	0	0	0	0	0	0	0	0	0	0
GREEN	GREEN (000)	0	0	0	0	0	0	0	0	0	0	0	0	0	0	0	0	0	0	0	0	0	0	0	0
	GREEN (001)	0	0	0	0	0	0	0	0	0	0	0	0	0	0	0	1	0	0	0	0	0	0	0	0
							
	GREEN (254)	0	0	0	0	0	0	0	0	1	1	1	1	1	1	1	0	0	0	0	0	0	0	0	0
	GREEN (255)	0	0	0	0	0	0	0	0	1	1	1	1	1	1	1	1	0	0	0	0	0	0	0	0
BLUE	BLUE (000)	0	0	0	0	0	0	0	0	0	0	0	0	0	0	0	0	0	0	0	0	0	0	0	0
	BLUE (001)	0	0	0	0	0	0	0	0	0	0	0	0	0	0	0	0	0	0	0	0	0	0	0	1
							
	BLUE (254)	0	0	0	0	0	0	0	0	0	0	0	0	0	0	0	0	1	1	1	1	1	1	1	0
	BLUE (255)	0	0	0	0	0	0	0	0	0	0	0	0	0	0	0	0	1	1	1	1	1	1	1	1

Product Specification

3-7. Power Sequence

3-6-1. LCD Driving circuit

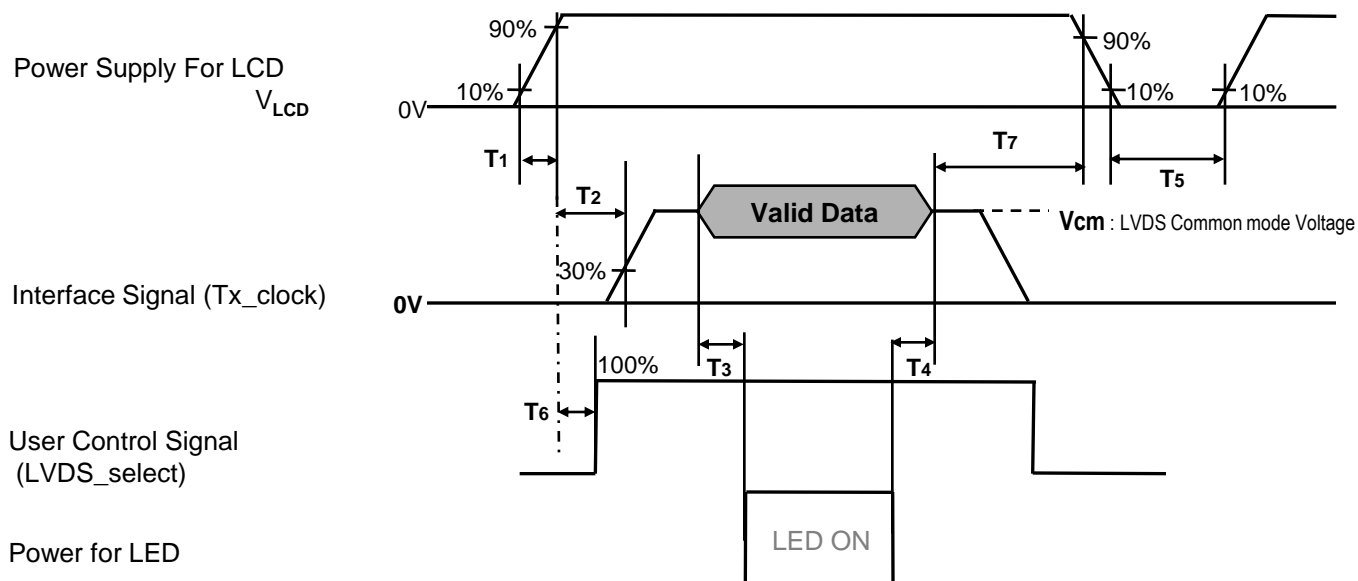

Table 7. POWER SEQUENCE

Parameter	Value			Unit	Notes
	Min	Typ	Max		
T1	0.5	-	20	ms	1
T2	0	-	-	ms	2
T3	400	-	-	ms	3
T4	100	-	-	ms	3
T5	1.0	-	-	s	4
T6	0	-	T2	ms	5
T7	0	-	-	ms	6

- Note :
1. Even though T1 is over the specified value, there is no problem if I2T spec of fuse is satisfied.
 2. If T2 is satisfied with specification after removing LVDS Cable, there is no problem.
 3. The T3 / T4 is recommended value, the case when failed to meet a minimum specification, abnormal display would be shown. There is no reliability problem.
 4. T5 should be measured after the Module has been fully discharged between power off and on period.
 5. If the on time of signals (Interface signal and user control signals) precedes the on time of Power (V_{LCD}), it will be happened abnormal display. When T6 is NC status, T6 doesn't need to be measured.
 6. It is recommendation specification that T7 has to be 0ms as a minimum value.
 - ※ Please avoid floating state of interface signal at invalid period.
 - ※ When the power supply for LCD (VLCD) is off, be sure to pull down the valid and invalid data to 0V.

Product Specification

4. Optical Specification

Optical characteristics are determined after the unit has been 'ON' and stable in a dark environment at $25\pm 2^{\circ}\text{C}$. The values are specified at 50cm from the LCD surface at a viewing angle of Φ and θ equal to 0° . FIG. 1 shows additional information concerning the measurement equipment and method.

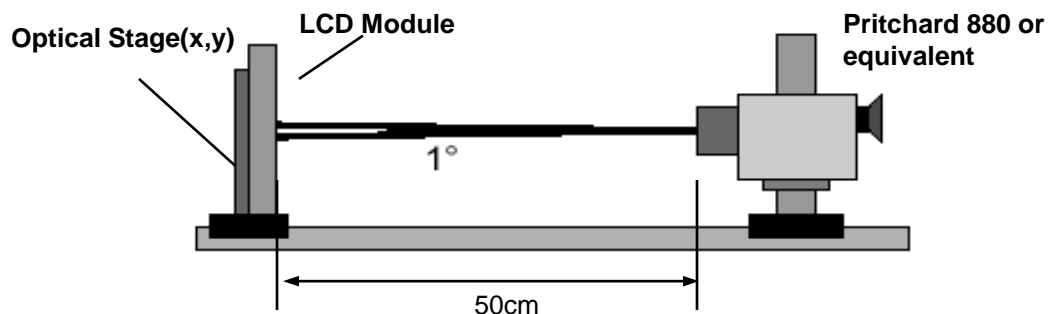

FIG. 1 Optical Characteristic Measurement Equipment and Method

$T_a = 25\pm 2^{\circ}\text{C}$, $V_{\text{LCD}} = 12.0\text{V}$, $f_v = 60\text{Hz}$, $D_{\text{clk}} = 74.25\text{MHz}$,
Back Light : LGD B/L

Table 8. OPTICAL CHARACTERISTICS

Parameter		Symbol	Value			Unit	Note	
			Min	Typ	Max			
Contrast Ratio		CR	840	1200	-		1	
Response Time	Variation	G to G σ					5	
	Gray to Gray (BW)	G to G BW				ms	4	
Color Coordinates [CIE1931]	RED	R x		0.650				
		R y		0.335				
	GREEN	G x	Typ	0.305	Typ			
		G y	-0.03	0.581	+0.03			
	BLUE	B x		0.149				
		B y		0.062				
Viewing Angle	2D (CR>10)	right($\phi=0^{\circ}$)	θ_r (x axis)	89	-	-	degree	6
		left ($\phi=180^{\circ}$)	θ_l (x axis)	89	-	-		
		up ($\phi=90^{\circ}$)	θ_u (y axis)	89	-	-		
		down ($\phi=270^{\circ}$)	θ_d (y axis)	89	-	-		
	3D (CT \leq 10%)	up + down	θ_u (y axis) + θ_d (y axis)	11	-	-	degree	8
		up	θ_u (y axis)	-	-	-	degree	
	down	θ_d (y axis)	-	-	-	degree		
Gray Scale			-	-	-		7	

Product Specification

Note : 1. Contrast Ratio(CR) is defined mathematically as :

$$\text{Contrast Ratio} = \frac{\text{Surface Luminance with all white pixels}}{\text{Surface Luminance with all black pixels}}$$

It is measured at center 1-point.

2. Response time is the time required for the display to transit from any gray to white (Rise Time, Tr_R) and from any gray to black (Decay time, Tr_D). For additional information see the FIG. 3.

※ G to G_{BW} Spec stands for average value of all measured points.

Photo Detector : RD-80S / Field : 2 °

3. G to G_{σ} is Variation of Gray to Gray response time composing a picture

$$G \text{ to } G(\sigma) = \sqrt{\frac{\sum(X_i - u)^2}{N}} \quad \begin{array}{l} X_i = \text{Individual Data} \\ u = \text{Data average} \\ N : \text{The number of Data} \end{array}$$

4. Viewing angle is the angle at which the contrast ratio is greater than 10. The angles are determined for the horizontal or x axis and the vertical or y axis with respect to the z axis which is normal to the LCD module surface. For more information, see the FIG. 4.

5. Gray scale specification

Gamma Value is approximately 2.2. For more information, see the Table 9.

6. 3D performance specification is expressed by 3D luminance and 3D viewing angle.

Table 9. GRAY SCALE SPECIFICATION

Gray Level	Luminance [%] (Typ)
L0	TBD
L15	0.27
L31	1.04
L47	2.49
L63	4.68
L79	7.66
L95	11.5
L111	16.1
L127	21.6
L143	28.1
L159	35.4
L175	43.7
L191	53.0
L207	63.2
L223	74.5
L239	86.7
L255	100

Product Specification

Measuring point for Contrast Ratio

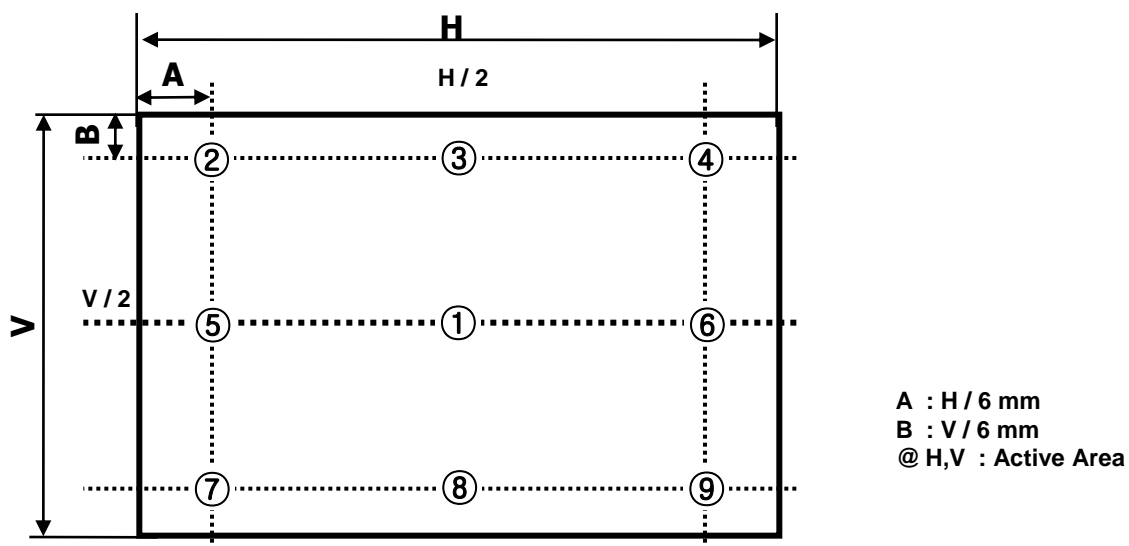

FIG. 2 5 Points for Contrast Ratio

Response time is defined as the following figure and shall be measured by switching the input signal for "Gray(N)" and "Black or White".

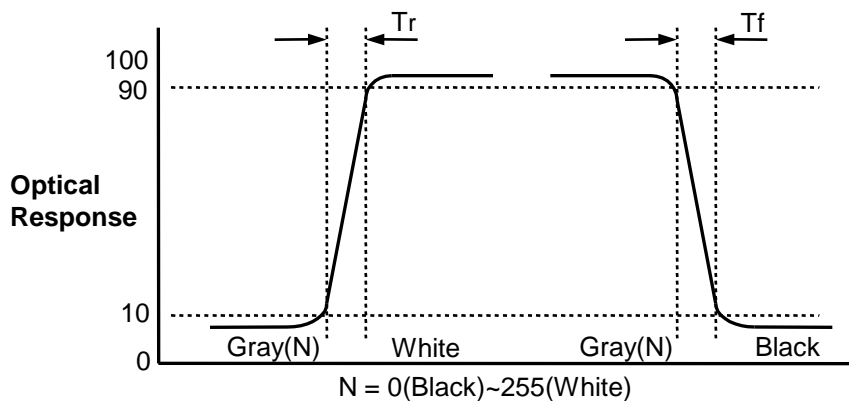

FIG. 3 Response Time

Dimension of viewing angle range

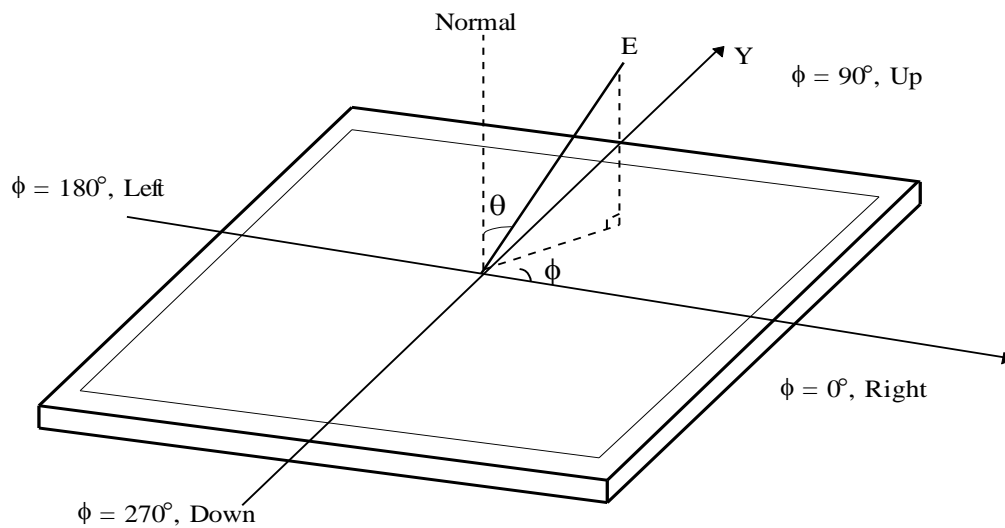
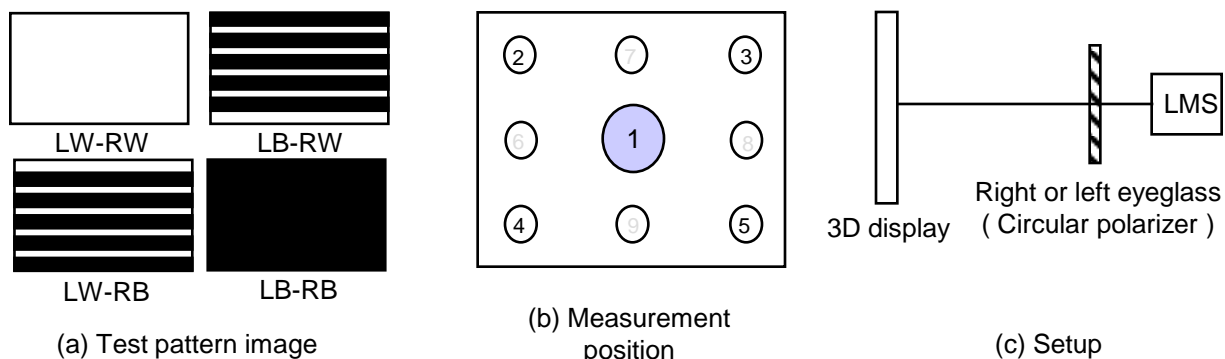
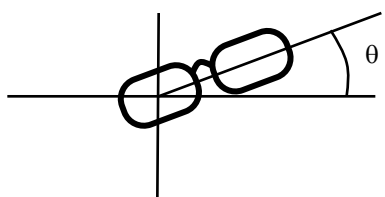

FIG. 4 Viewing Angle

Product Specification



< FIG. 5. Measurement configuration >



< FIG. 6. Positioning eyeglass >

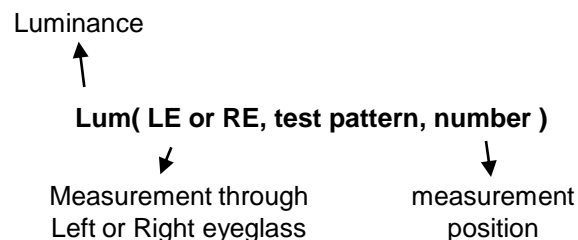

< FIG. 7. Notation of luminance measurement >

In order to measure 3D crosstalk and 3D viewing angle, it need to be prepared as below;

1) Measurement configuration

4-Test pattern images. Refer to FIG 5.

- LW-RW : White for left and right eye
- LW-RB : White for left eye and Black for right eye
- LB-RW : Black for left eye and white for right eye
- LB-RB : Black for left eye and right eye

Image files where black and white lines are displayed on even or odd lines.

Luminance measurement system (LMS) with narrow FOV (field of view) is used. Refer to FIG 1.

2) Positioning Eyeglass (refer to appendix-VII for standard specification of eyeglass)

Find angle of minimum transmittance.

This value would be provided beforehand or measured by the following steps;

- (i) Test image (LB-RW) is displayed.
- (ii) Left eyeglass are placed in front of LMS and luminance is measured, rotating right eyeglass such as FIG 6. The notation for luminance measurement is "Lum(LE, LB-RW,1)".
- (iii) Find the angle where luminance is minimum.

* Following measurements should be performed at the angle of minimum transmittance of eyeglass.

Product Specification

3) Measurement of 3D crosstalk

- (i) Test image (LB-RW, LW-RB and LB-RB) is displayed.
- (ii) Right or left eyeglass are placed in front of LMS successively and luminance is measured for position 1. with rotating LMS or sample vertically.

$$\frac{\text{Lum}(\text{LE}, \text{LB-RW}, 1) - \text{Lum}(\text{LE}, \text{LB-RB}, 1)}{\text{Lum}(\text{LE}, \text{LW-RB}, 1) - \text{Lum}(\text{LE}, \text{LB-RB}, 1)}$$

or

$$\frac{\text{Lum}(\text{RE}, \text{LW-RB}, 1) - \text{Lum}(\text{RE}, \text{LB-RB}, 1)}{\text{Lum}(\text{RE}, \text{LB-RW}, 1) - \text{Lum}(\text{RE}, \text{LB-RB}, 1)}$$

4) Measurement of 3D Viewing Angle

3D viewing angle is the angle at which the 3D crosstalk is under 10%. The angles are determined for the vertical or y axis with respect to the z axis which is normal to the LCD module surface and measured for position 1. For more information , see the Fig 8

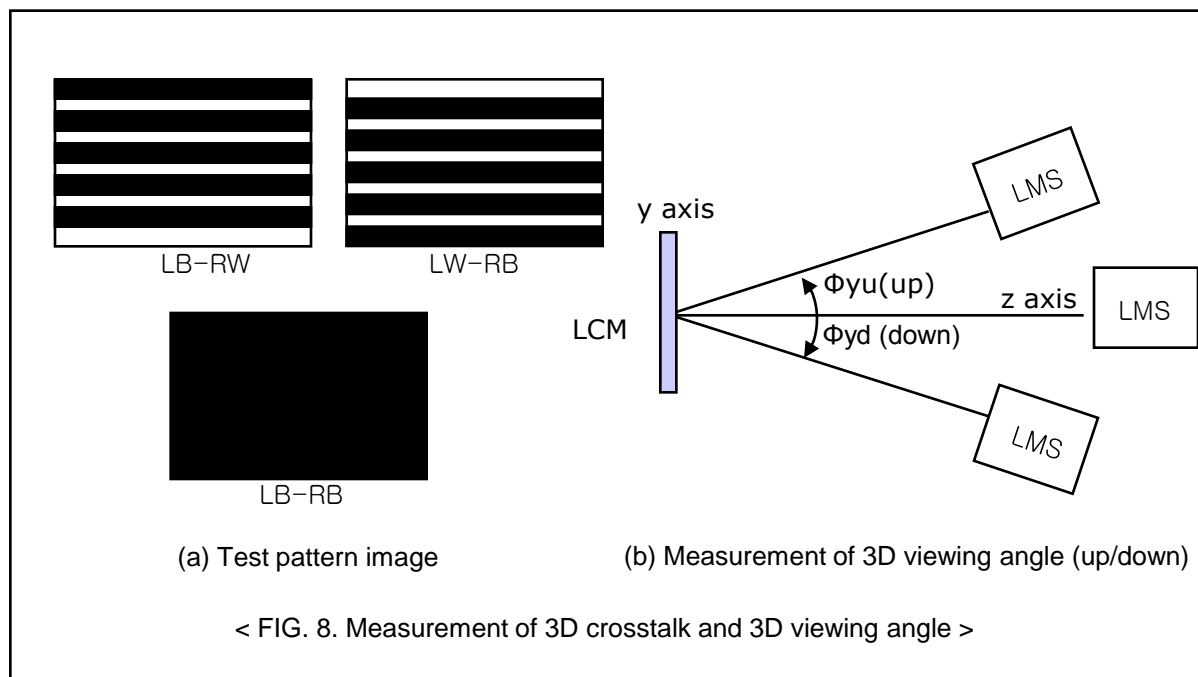

Product Specification

5. Mechanical Characteristics

Table 10 provides general mechanical characteristics.

Table 10. MECHANICAL CHARACTERISTICS

Item	Value	
Outline Dimension (Only Glass)	Horizontal	943.6mm
	Vertical	538.3mm
	Thickness	1.4 mm
Active Display Area	Horizontal	927.936mm
	Vertical	521.964mm
Weight	1.5kg(typ)	
Surface Treatment	Hard coating(2H) Anti-glare treatment of the front polarizer : Haze 1%(Typ.)	

Note : Please refer to a mechanical drawing in terms of tolerance at the next page.

Product Specification

[FRONT VIEW]

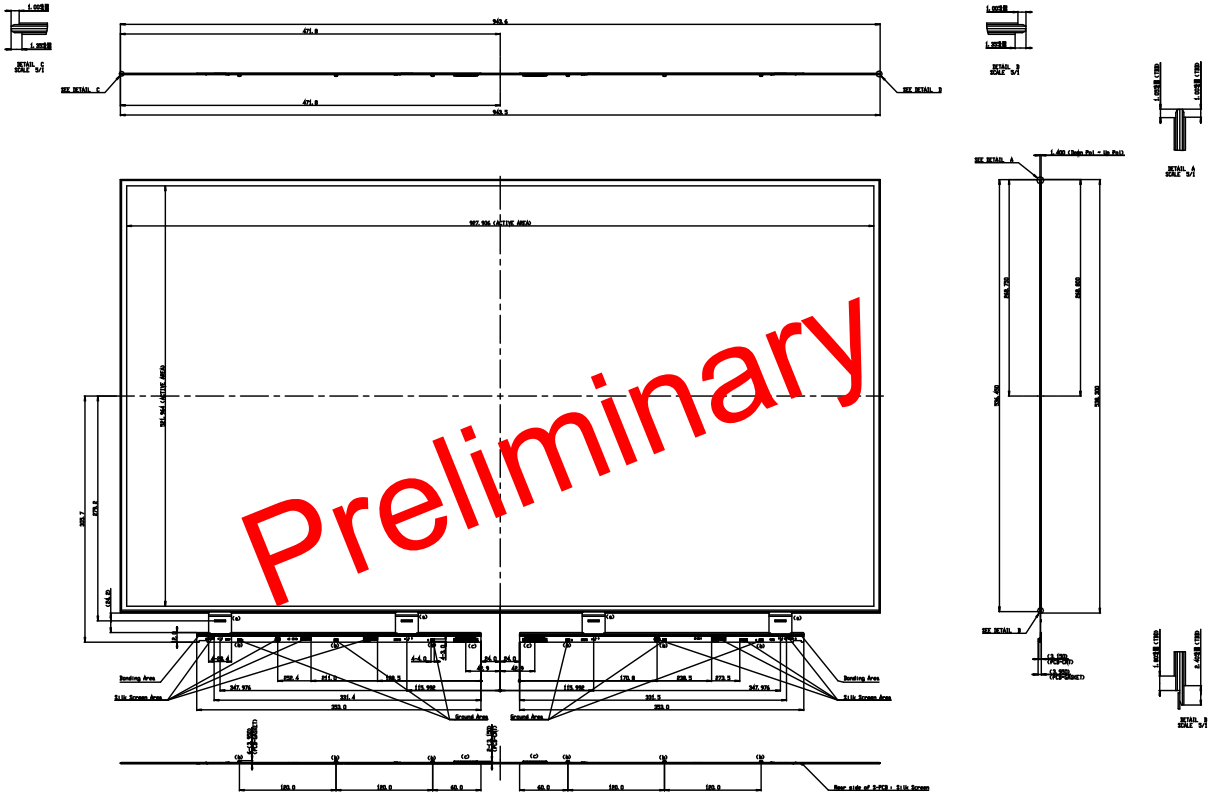

Product Specification

6-2. Control Board Assembly Dimension

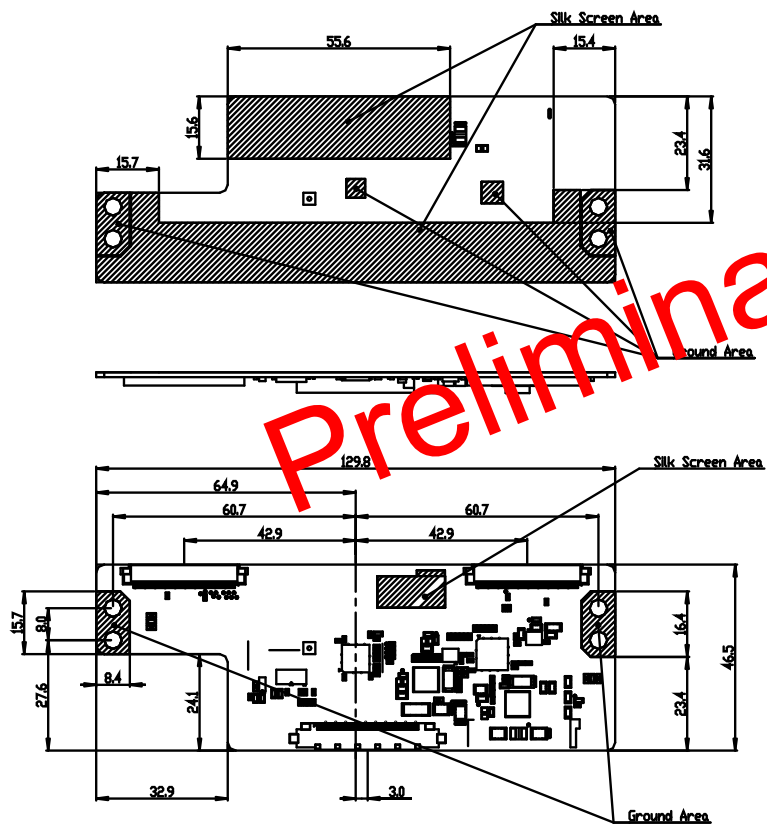

- NOTE.
1. This drawing describes the necessary dimension in Control board to assembly with customer's backlight system.
 2. The specified dimension, non-specified dimension and its tolerances can be changeable, and hence values are used for reference only.

Preliminary

Product Specification

7. Reliability**Table 11. ENVIRONMENT TEST CONDITION**

No.	Test Item	Condition
1	High temperature storage test	Ta= 60°C 90% 240h
2	Low temperature storage test	Ta= -20°C 240h
3	High temperature operation test	Ta= 50°C 50%RH 500h
4	Low temperature operation test	Ta= 0°C 500h
5	Humidity condition Operation	Ta= 40 °C ,90%RH
6	Altitude operating storage / shipment	0 - 16,400 ft 0 - 40,000 ft

Note : Before and after Reliability test, LCM should be operated with normal function.

8. International Standards

8-1. Safety

- a) UL 60065, Underwriters Laboratories Inc.
Audio, Video and Similar Electronic Apparatus - Safety Requirements.
- b) CAN/CSA C22.2 No.60065:03, Canadian Standards Association.
Audio, Video and Similar Electronic Apparatus - Safety Requirements.
- c) IEC 60065, The International Electrotechnical Commission (IEC).
Audio, Video and Similar Electronic Apparatus - Safety Requirements.

8-2. Environment

- a) RoHS, Directive 2011/65/EU of the European Parliament and of the council of 8 June 2011

Product Specification

9. Packing**9-1. Packing Form**

- a) Package quantity in one Pallet : 80ea
- b) Pallet Size :1140 mm(L) X 740 mm(W) X 1090 mm(H)

Product Specification

10. Precautions

Please pay attention to the followings when you use this TFT LCD module.

10-1. Handling Precautions

- (1) Please attach the surface transparent protective film to the surface in order to protect the polarizer. Transparent protective plate should have sufficient strength in order to resist external force.
- (2) Acetic acid type and chlorine type materials for the cover case are not desirable because the former generates corrosive gas of attacking the polarizer at high temperature and the latter causes circuit break by electro-chemical reaction.
- (3) Do not touch, push or rub the exposed polarizers with glass, tweezers or anything harder than HB pencil lead. And please do not rub with dust clothes with chemical treatment. Do not touch the surface of polarizer for bare hand or greasy cloth. (Some cosmetics are detrimental to the polarizer.)
- (4) After removing the protective film, when the surface becomes dusty, please wipe gently with absorbent cotton or other soft materials like chamois soaked with petroleum benzene. Do not use acetone, toluene and alcohol because they cause chemical damage to the polarizer.
- (5) Wipe off saliva or water drops as soon as possible. Their long time contact with polarizer causes deformations and color fading.
- (6) Since a module is composed of electronic circuits, it is not strong to electrostatic discharge. Make certain that treatment persons are connected to ground through wrist band etc. And don't touch interface pin directly. Panel ground path should be connected to metal ground.
- (7) Please make sure to avoid external forces applied to the Source PCB and D-IC during the process of handling or assembling the TV set. If not, it causes panel damage or malfunction.
- (8) Panel and BLU should be protected from the static electricity. If not, it causes IC damage.
- (9) Do not pull or fold the source D-IC which connect the source PCB and the panel.
- (10) Panel(board ass'y) should be put on the BLU structure precisely to avoid mechanical impact.
- (11) FFC Cable should be connected between System board and Source PCB correctly.
- (12) Mechanical structure for backlight system should be designed for sustaining board ass'y safely.
- (13) Surface temperature of the Source D-IC should be controlled under 100°C with TV Set status. If not, problems such as IC damage or decrease of lifetime could occur.

10-2. Operating Precautions

- (1) Response time depends on the temperature. (In lower temperature, it becomes longer.)
- (2) Brightness depends on the temperature. (In lower temperature, it becomes lower.)
And in lower temperature, Stable time (required time that brightness is stable after turned on) becomes longer
- (3) Be careful for condensation at sudden temperature change. Condensation makes damage to polarizer or electrical contacted parts. And after fading condensation, smear or spot will occur.
- (4) When fixed patterns are displayed for a long time, remnant image is likely to occur.
- (5) Module has high frequency circuits. Sufficient suppression to the electromagnetic interference shall be done by system manufacturers. Grounding and shielding methods may be important to minimize the interference.

Product Specification

10-3. Protection Film

- (1) Please keep attaching the protection film before assembly.
- (2) Please peel off the protection film slowly.
- (3) Please peel off the protection film just like shown in the Fig.1
- (4) Ionized air should be blown over during the peeling.
- (5) Source PCB should be connected to the ground when peel off the protection film.
- (6) The protection film should not be contacted to the source D-IC during peeling it off.

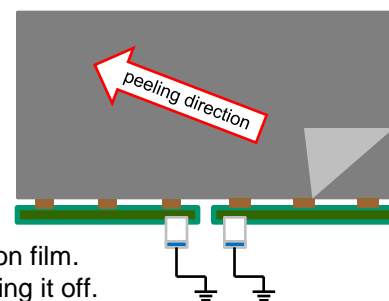

< Fig. 1 >

10-4. Storage Precautions

When storing modules as spares for a long time, the following precautions are necessary.

- (1) Temperature : 5 ~ 40 °C
- (2) Humidity : 35 ~ 75 %RH
- (3) Period : 6 months
- (4) Control of ventilation and temperature is necessary.
- (5) Please make sure to protect the product from strong light exposure, water or moisture. Be careful for condensation.
- (6) Please keep the modules at a circumstance shown below Fig. 2

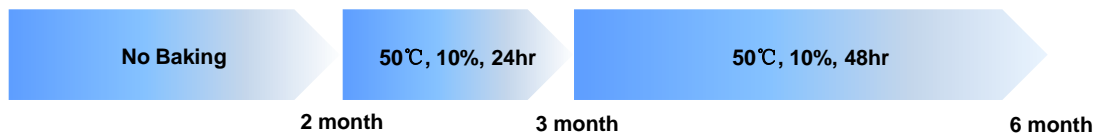

< Fig. 2 >

10-5. Packing Precautions

Product assembled into module should be stored in the Al-bag(cover case).

10-6. Operating condition guide

- (1) The LCD product should be operated under normal conditions. Normal condition is defined as below;
 - Temperature : 5 ~ 40 °C, normal humidity
 - Display pattern : continually changing pattern (Not stationary)
- (2) If the product will be used in extreme conditions such as high temperature, display patterns or operation time etc.,

It is strongly recommended to contact LGD for Qualification engineering advice. Otherwise, its reliability and function may not be guaranteed. Extreme conditions are commonly found at Airports, Transit Stations, Banks, Stock market, and Controlling systems. The LCD product should be applied by global standard environment. (refer ETSI EN 300, IEC 60721)

Product Specification

APPENDIX-I-1

■ Pallet Ass'y

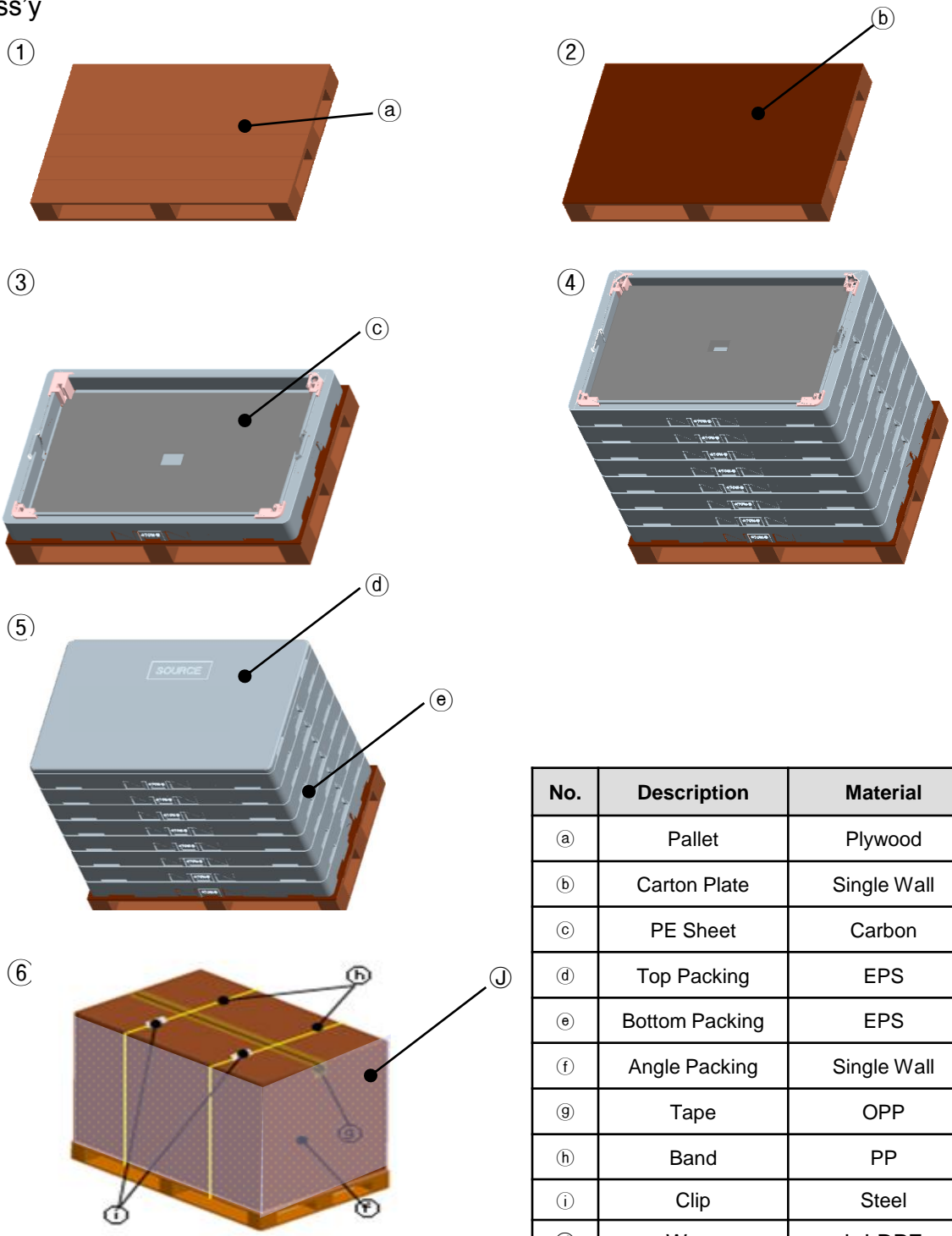

No.	Description	Material
(a)	Pallet	Plywood
(b)	Carton Plate	Single Wall
(c)	PE Sheet	Carbon
(d)	Top Packing	EPS
(e)	Bottom Packing	EPS
(f)	Angle Packing	Single Wall
(g)	Tape	OPP
(h)	Band	PP
(i)	Clip	Steel
(j)	Wrap	L-LDPE

Product Specification

APPENDIX-I-2

■ Control PCB Packing Ass'y

- a) Control PCB Qty / Box : 80 pcs
- b) Tray Qty / Box : 9Tray(Upperst Tray Is empty)
- c) Tray Size : 353 X 353 X 16
- d) Box size : 368 X 355 X 110

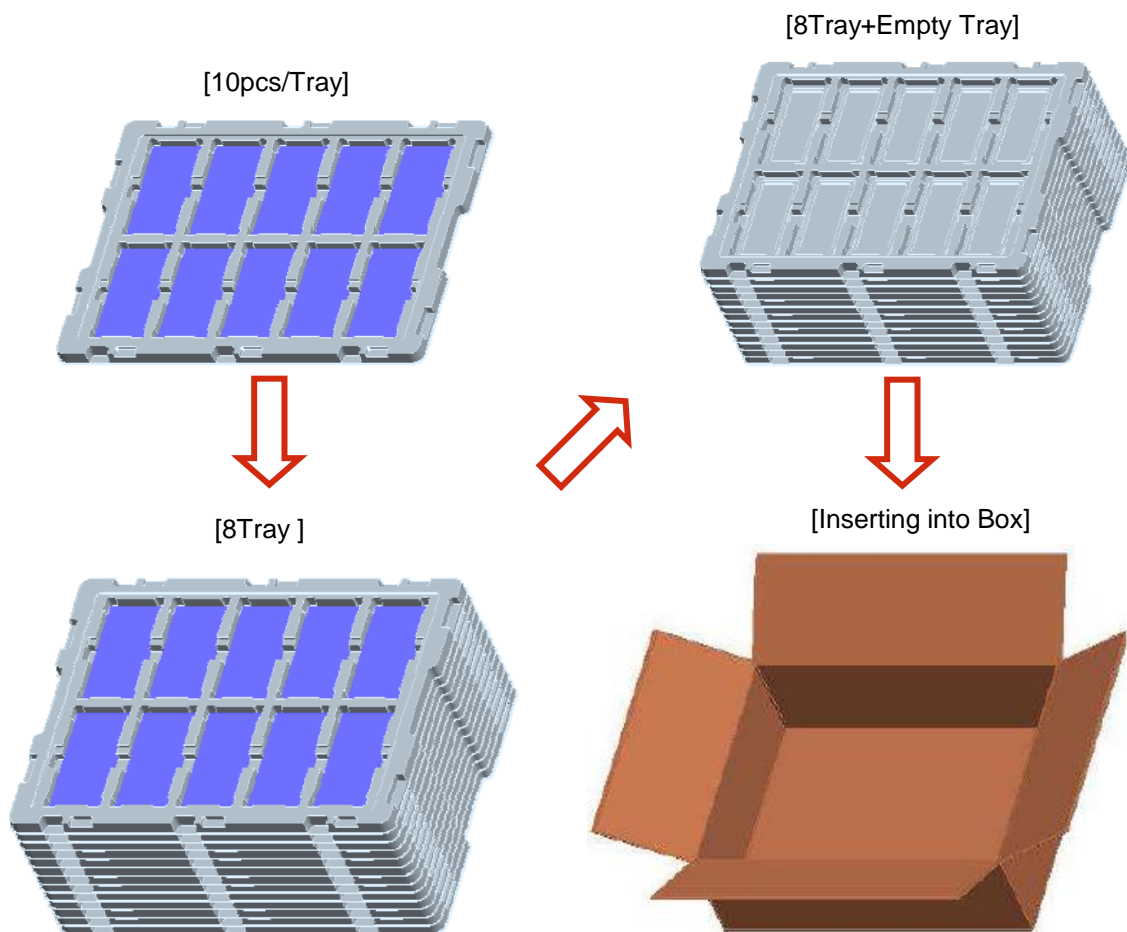

NO.	DESCRIPTION	MATERIAL
1	PCB Packing A,ssy	-
2	Tray	PET
3	Box	SWR4

Product Specification

APPENDIX- II-1

■ Serial Label

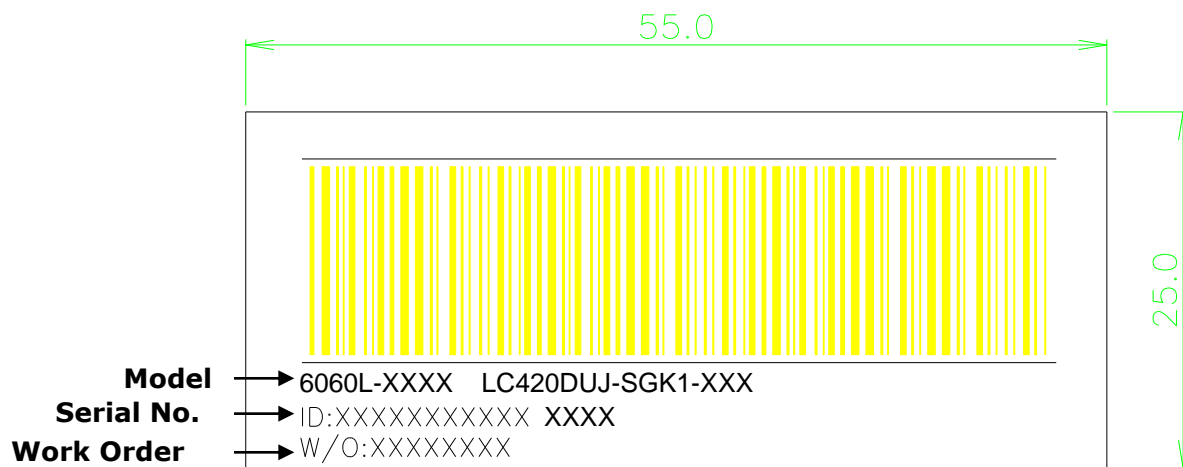

Product Specification

APPENDIX- II-2

■ Box Label



■ Pallet Label

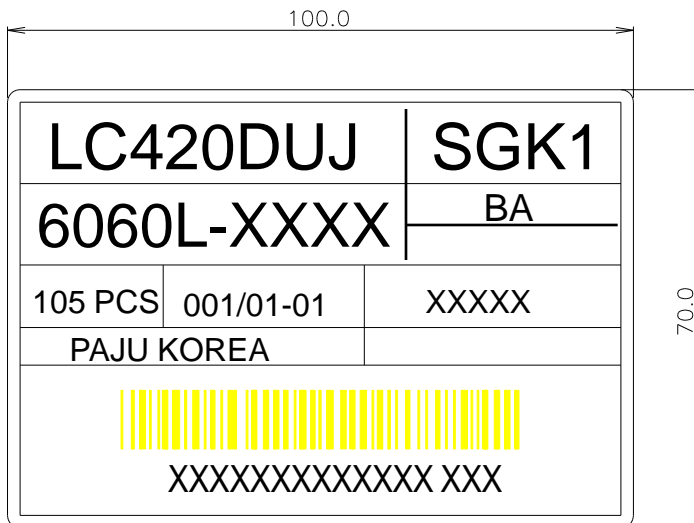

Product Specification

APPENDIX- III-1

■ Required signal assignment for Flat Link (Thine : THC63LVD103) Transmitter(Pin7= "L" or "NC")

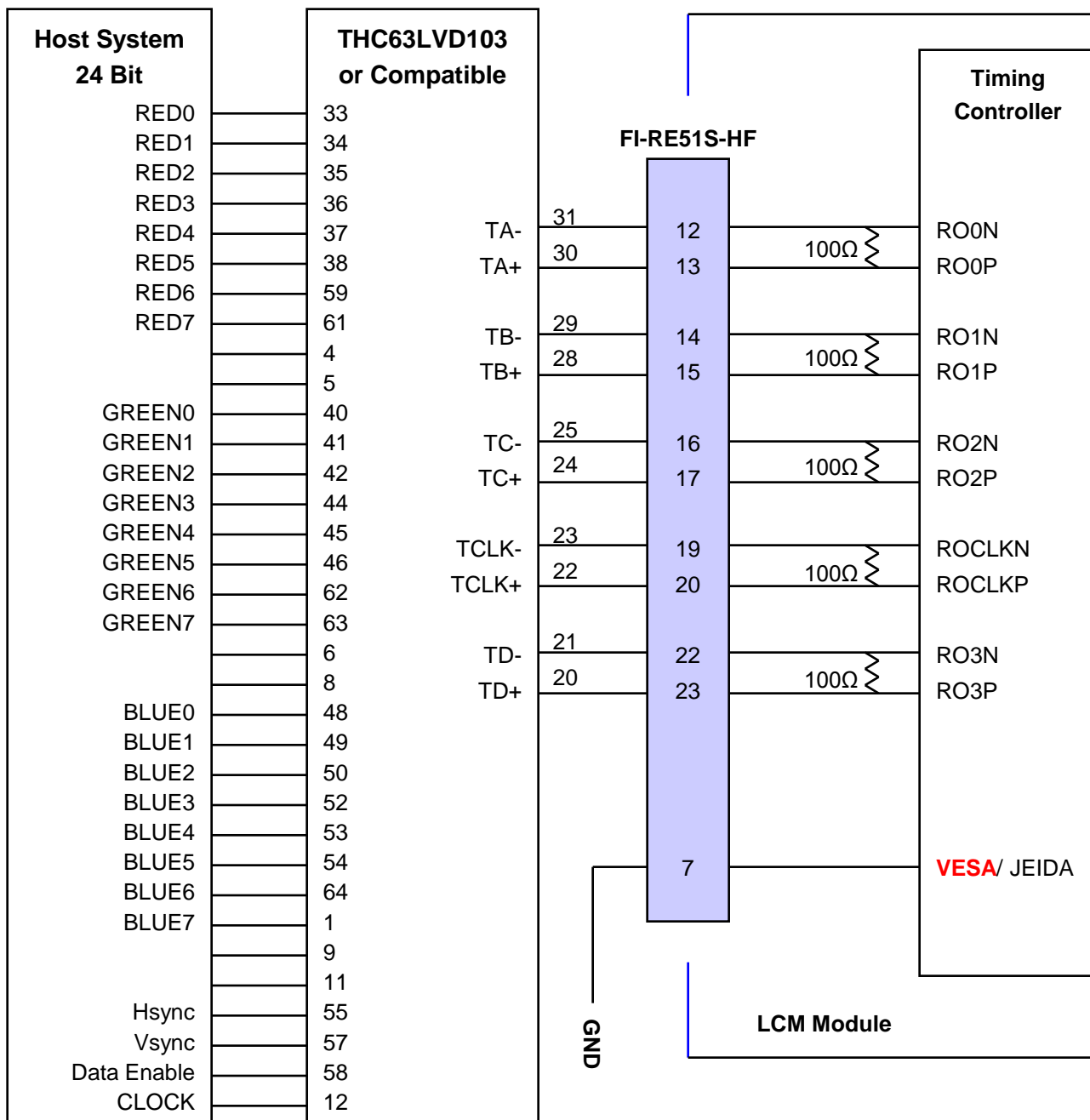

Note: 1. The LCD module uses a 100 Ohm[Ω] resistor between positive and negative lines of each receiver input.

2. Refer to LVDS Transmitter Data Sheet for detail descriptions. (THC63LVD103 or Compatible)

3. '7' means MSB and '0' means LSB at R,G,B pixel data.

Product Specification

APPENDIX- III-2

■ Required signal assignment for Flat Link (Thine : THC63LVD103) Transmitter(Pin7= "H")

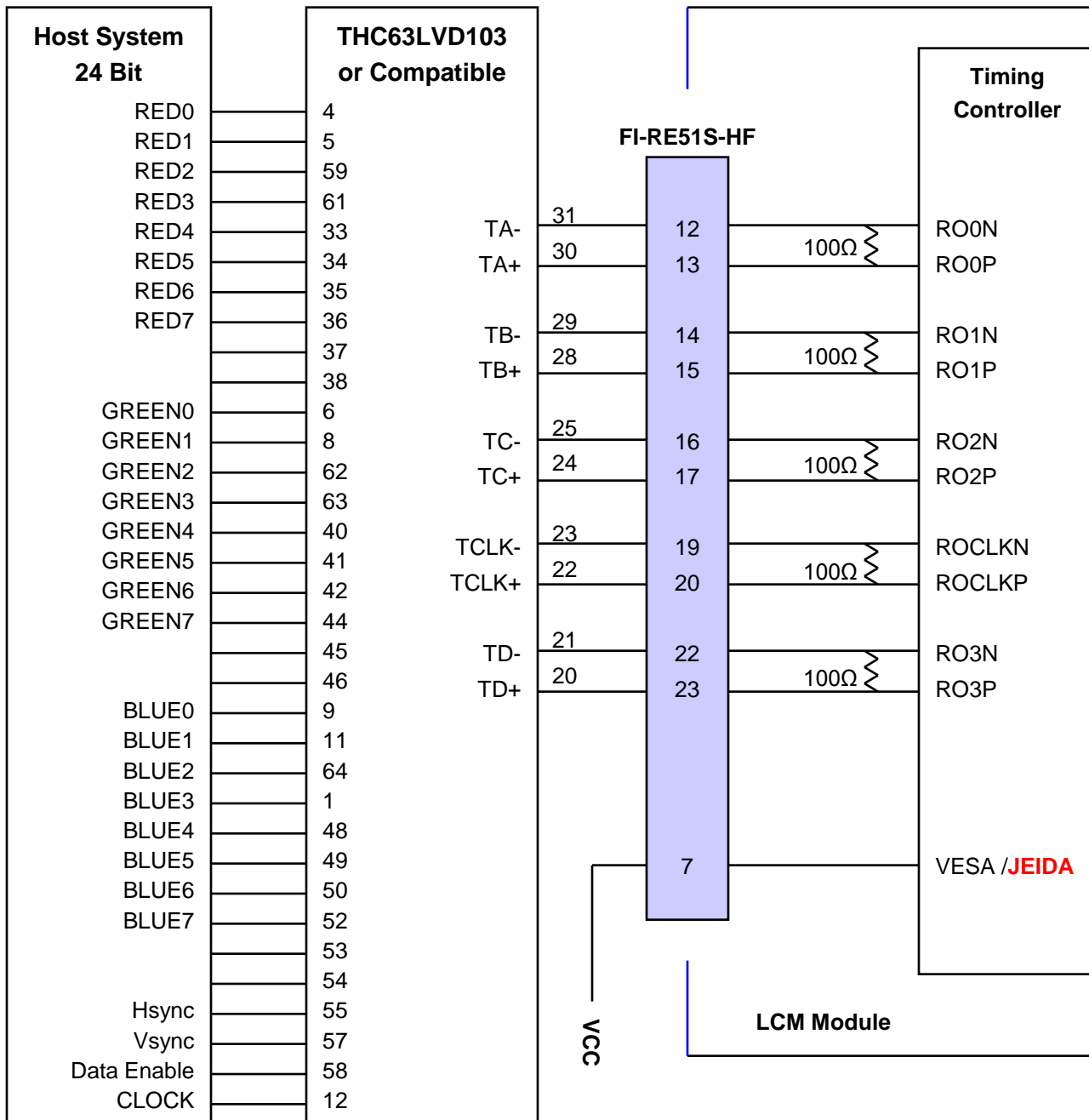

- Note :1. The LCD module uses a 100 Ohm[Ω] resistor between positive and negative lines of each receiver input.
 2. Refer to LVDS Transmitter Data Sheet for detail descriptions. (THC63LVD103 or Compatible)
 3. '7' means MSB and '0' means LSB at R,G,B pixel data.

APPENDIX- IV

■ LVDS Data-Mapping Information (8 Bit)

1) LVDS Select : "H" Data-Mapping (JEIDA format)

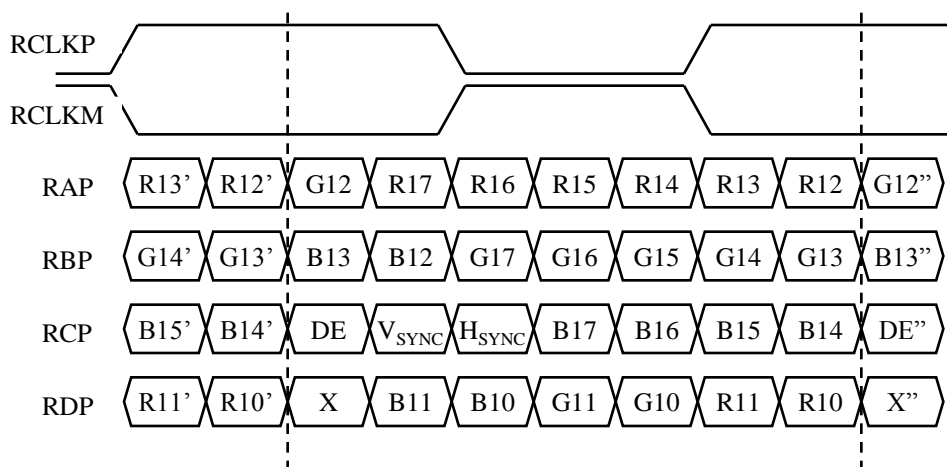

2) LVDS Select : "L" Data-Mapping (VESA format)

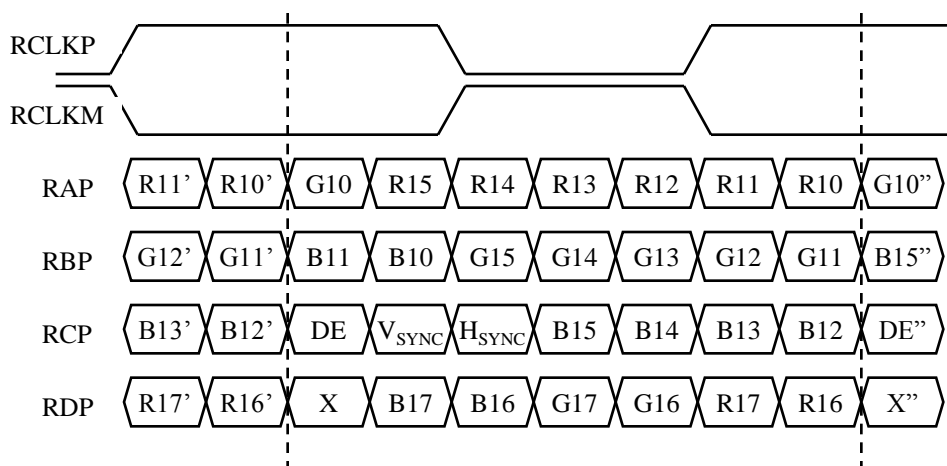

APPENDIX- V

■ Option Pin Circuit Block Diagram

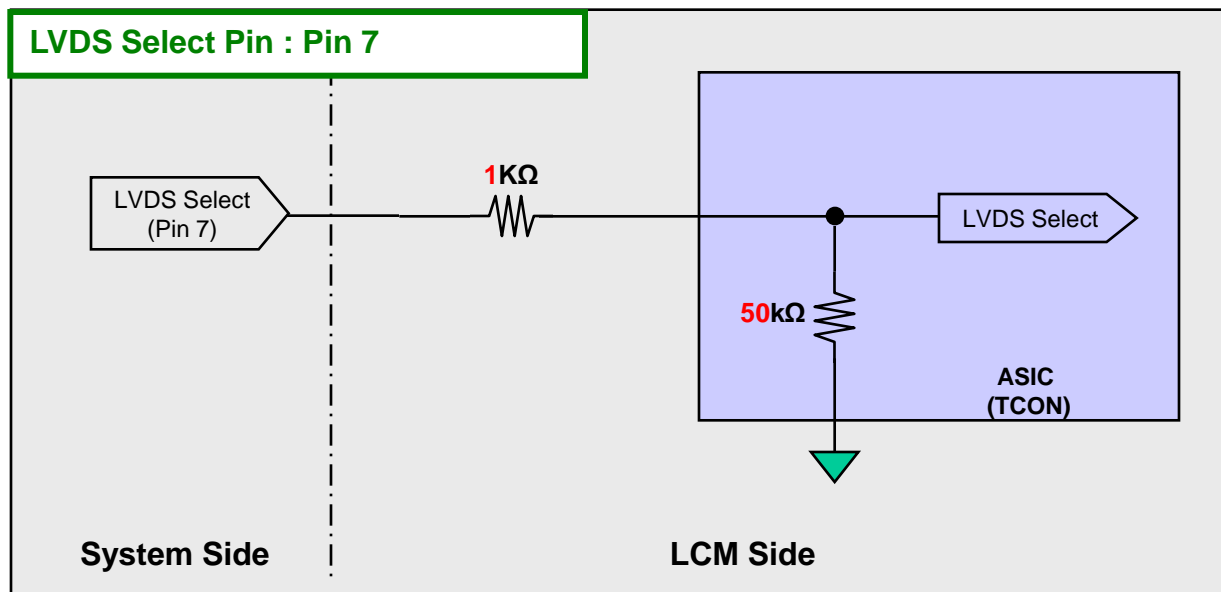
1) Circuit Block Diagram of **LVDS Format** Selection pin

Product Specification

APPENDIX- VI

■ Standard specification of Eyeglasses

This is recommended data of Eyeglasses for LC420DUJ-SGK1 model. (details refer to table)

For each item, depending on the eyeglass manufacturer tolerances may occur, this tolerance can affect 3D performance. (3D Crosstalk, 3D luminance, 3D viewing angle)

<Table. Standard specification of Eyeglasses>

Design item of Eyeglasses		Left	Right	Remark
Optical axis	a) Slow axis of retarder	-45°	45°	Refer to drawing
	b) Transmission axis of polarizer	0°	0°	
Retardation value	Retarder	125nm		@550nm

※Recommended polarizer
Polarization efficiency: more than 99.90%

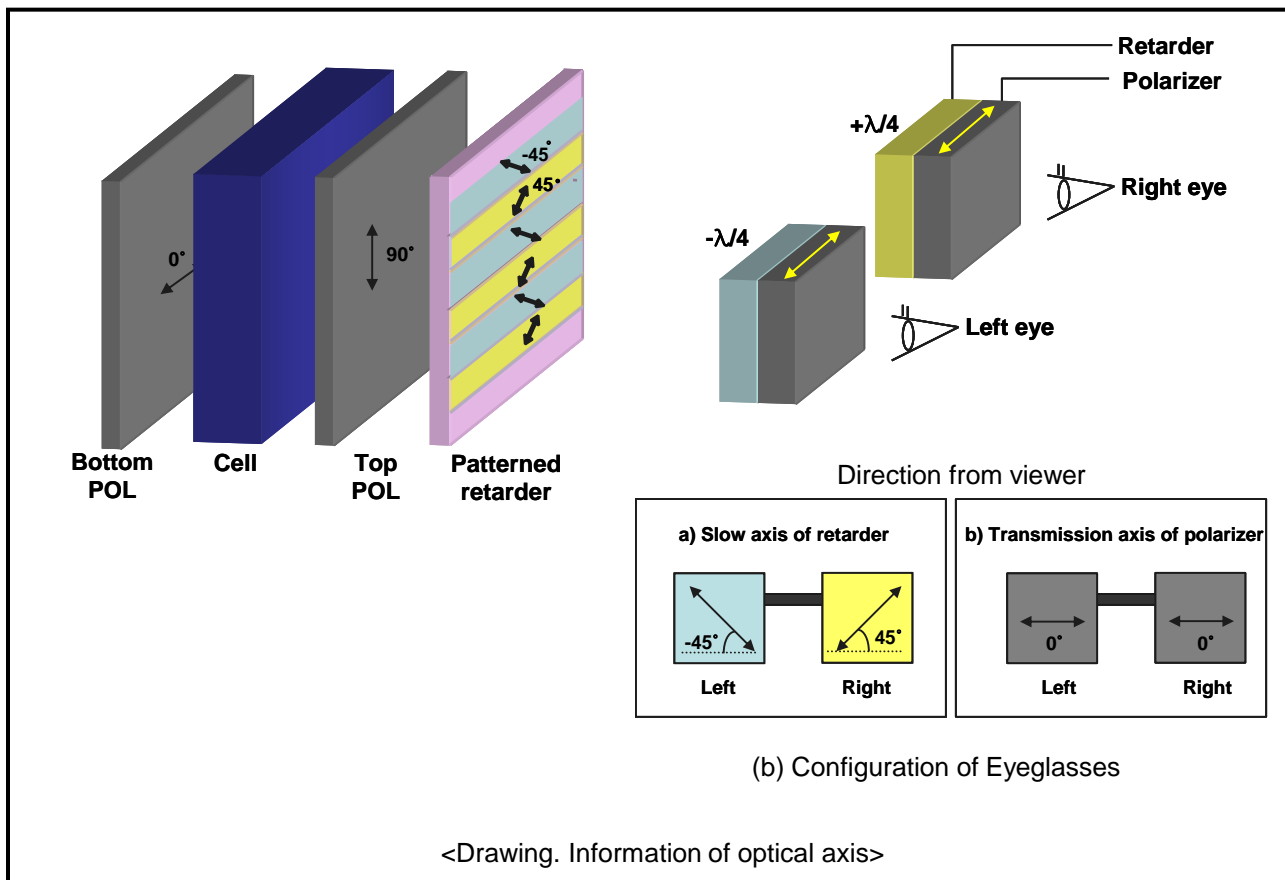

Product Specification

APPENDIX-VII-1

■ Flicker Adjustment

Parameter	Unit	Min	Typ	Max	Note
Inversion Method	-	H2-Dot Inversion			
Adjust Pattern / Gray Level	-	G H2Dot Full Flicker / 127Gray			60Hz
Position	-	Center			
Voltage range	V	6.20	6.50	6.80	

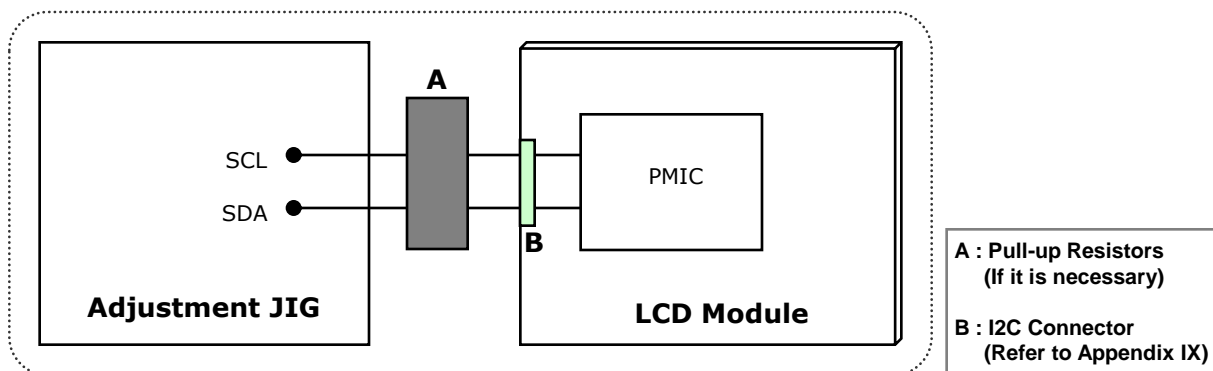
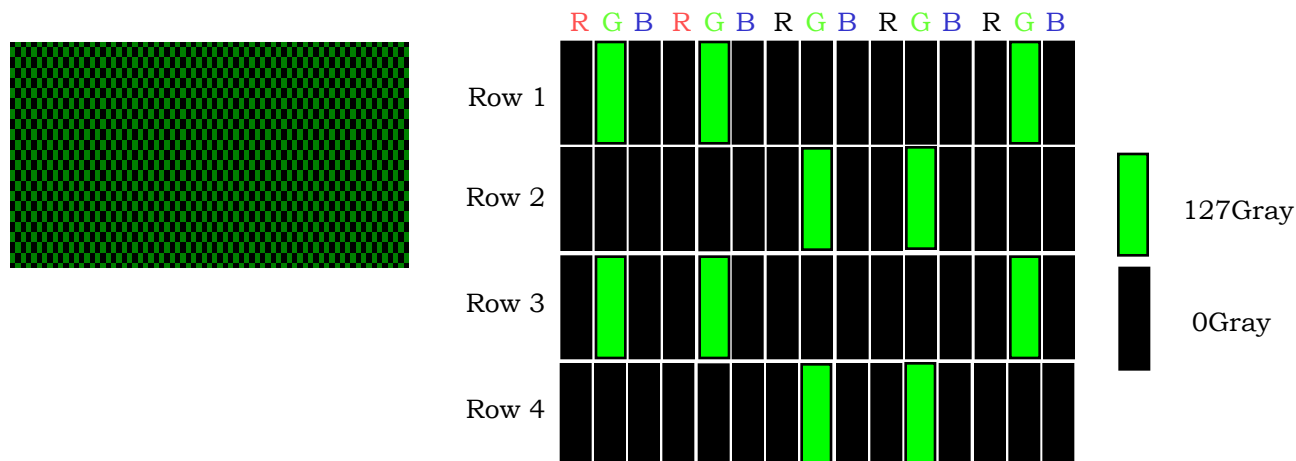

APPENDIX-VII-2

Vcom Adjustment

MODULE 51 Pin CNT(CN1) PIN CONFIGURATION

Pin No	Description	Note
1~3	NC	
4	SDA	
5	SCL	
6~51	-	

LC420DUJ-SGK1 Control PCB Assembly uses TI PWM IC(TPS65175).
PWM IC (Slave) Address is 40h (01000000), Vcom Register address is 0x15, 0x16

If you need detailed information, Please refer to TI PWM IC(TPS65175) Data Sheet or contact with TI company.

APPENDIX-VIII**■ The reference method of BL dimming**

It is recommended to use synchronous V-sync frequency to prevent waterfall
(Vsync * 2 =P-Dim Frequency)

Product Specification

APPENDIX-IX

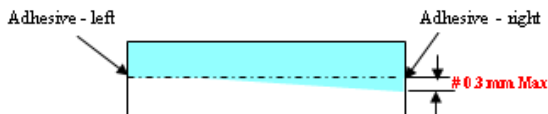
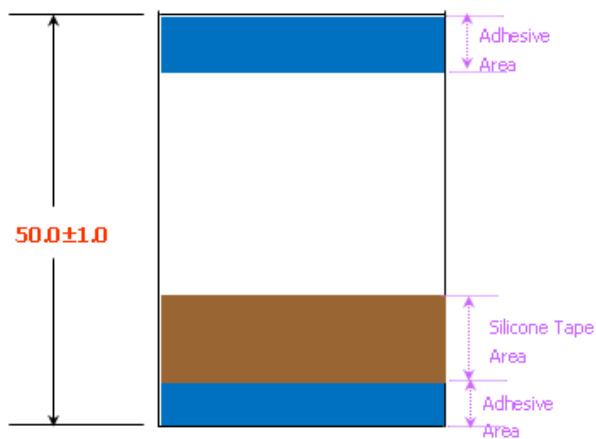
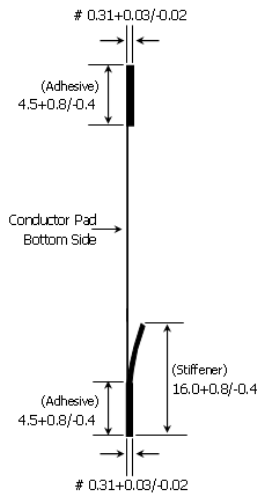
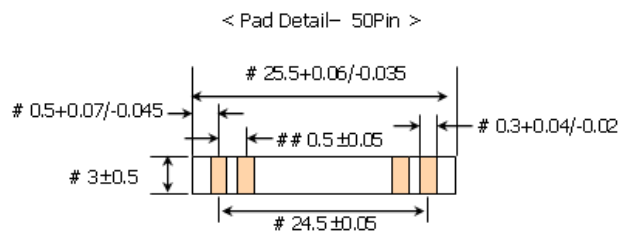

◆ Note

- Layer : Single Side
- Pad : GOLD Plating
- # ≥ Cpk 1.0
- ## ≥ Cpk 1.33
- Stiffener color : Sky Blue
(Silicone Tape color : Brown)
- H-F
- Dimensions unit : mm

- Material List

MATERIAL LIST			
APPLICATION	STANDARD	MATERIAL	REFERENCE
1. CONDUCTOR	GOLD PLATED COPPER WIRE	1. 99.99% COPPER	1. Tolerance - THICKNESS : ±0.01 - WIDTH : +0.04 -0.02
		2. GOLD PLATED	2. ELONGATION(%) : 10 MORE THAN 3. TENSION : (KGF) 0.2 MORE THAN 4. GOLD THICKNESS : 0.05 μm MIN *MAKER : DOSOL Processing : EunSung
2. INSULATION	POLYESTER FILM (PET/PET)	1. POLYESTER BASE FILM : 0.025 mm	UL VW-1 FLAME Width : 120mm Length : 500M
		2. POLYESTER HOTMELT ADHESIVE : 0.035 mm TOTAL : 0.060 mm THICKNESS	UNIT : ROLL *MAKER : COSMOAMT/ SHINCHANG HOTMELT
3. SUPPORTING TAPE	POLYESTER FILM	1. POLYESTER BASE FILM : 0.188 mm	Width : 20.5mm Length : 250M Unit : ROLL
		2. POLYESTER HOTMELT ADHESIVE : 0.027 mm TOTAL THICKNESS : 0.215 mm	*MAKER : SUNGSHIN Trading/ COSMOAMT