



LC420EUE

Product Specification

SPECIFICATION FOR APPROVAL

(●) Preliminary Specification

() Final Specification

| | |
|-------|---------------------|
| Title | 42.0" WUXGA TFT LCD |
|-------|---------------------|

| | |
|-------|---------|
| BUYER | General |
| MODEL | |

| | |
|----------|----------------------|
| SUPPLIER | LG Display Co., Ltd. |
| *MODEL | LC420EUE |
| SUFFIX | SEM2 |

*When you obtain standard approval,
please use the above model name without suffix

| APPROVED BY | SIGNATURE DATE |
|-------------|-------------------|
| / | |
| / | |
| / | |

Please return 1 copy for your confirmation with your signature and comments.

| APPROVED BY | SIGNATURE DATE |
|---------------------------|-------------------|
| J.T. Kim / Team Leader | |
| REVIEWED BY | |
| Y.J. Heo / Project Leader | |
| PREPARED BY | |
| J.W. Yang / Engineer | |

**TV Product Development Dept.
LG Display Co., Ltd.**

Ver. 0.3

LC420EUE

Product Specification

CONTENTS

| Number | ITEM | Page |
|--------|--|------|
| | COVER | 1 |
| | CONTENTS | 2 |
| | RECORD OF REVISIONS | 3 |
| 1 | GENERAL DESCRIPTION | 4 |
| 2 | ABSOLUTE MAXIMUM RATINGS | 5 |
| 3 | ELECTRICAL SPECIFICATIONS | 6 |
| 3-1 | ELECTRICAL CHARACTERISTICS | 6 |
| 3-2 | INTERFACE CONNECTIONS | 8 |
| 3-3 | SIGNAL TIMING SPECIFICATIONS | 11 |
| 3-4 | SIGNAL TIMING WAVEFORMS | 12 |
| 3-5 | COLOR DATA REFERENCE | 15 |
| 3-6 | POWER SEQUENCE | 16 |
| 4 | OPTICAL SPECIFICATIONS | 18 |
| 5 | MECHANICAL CHARACTERISTICS | 24 |
| 6 | RELIABILITY | 27 |
| 7 | INTERNATIONAL STANDARDS | 28 |
| 7-1 | SAFETY | 28 |
| 7-2 | EMC | 28 |
| 7-3 | ENVIRONMENT | 28 |
| 8 | PACKING | 29 |
| 8-1 | DESIGNATION OF LOT MARK | 29 |
| 8-2 | PACKING FORM | 29 |
| 9 | PRECAUTIONS | 30 |
| 9-1 | MOUNTING PRECAUTIONS | 30 |
| 9-2 | OPERATING PRECAUTIONS | 30 |
| 9-3 | ELECTROSTATIC DISCHARGE CONTROL | 31 |
| 9-4 | PRECAUTIONS FOR STRONG LIGHT EXPOSURE | 31 |
| 9-5 | STORAGE | 31 |
| 9-6 | HANDLING PRECAUTIONS FOR PROTECTION FILM | 31 |

Product Specification

1. General Description

The LC420EUE is a Color Active Matrix Liquid Crystal Display with an integral Light Emitting Diode (LED) backlight system. The matrix employs a-Si Thin Film Transistor as the active element. It is a transmissive display type which is operating in the normally black mode. It has a 42.02 inch diagonally measured active display area with WUXGA resolution (1080 vertical by 1920 horizontal pixel array). Each pixel is divided into Red, Green and Blue sub-pixels or dots which are arrayed in vertical stripes. Gray scale or the luminance of the sub-pixel color is determined with a 8-bit gray scale signal for each dot. Therefore, it can present a palette of more than 16.7Million colors.

It has been designed to apply the 8-bit 2-port LVDS interface.

It is intended to support LCD TV, PCTV where high brightness, super wide viewing angle, high color gamut, high color depth and fast response time are important.

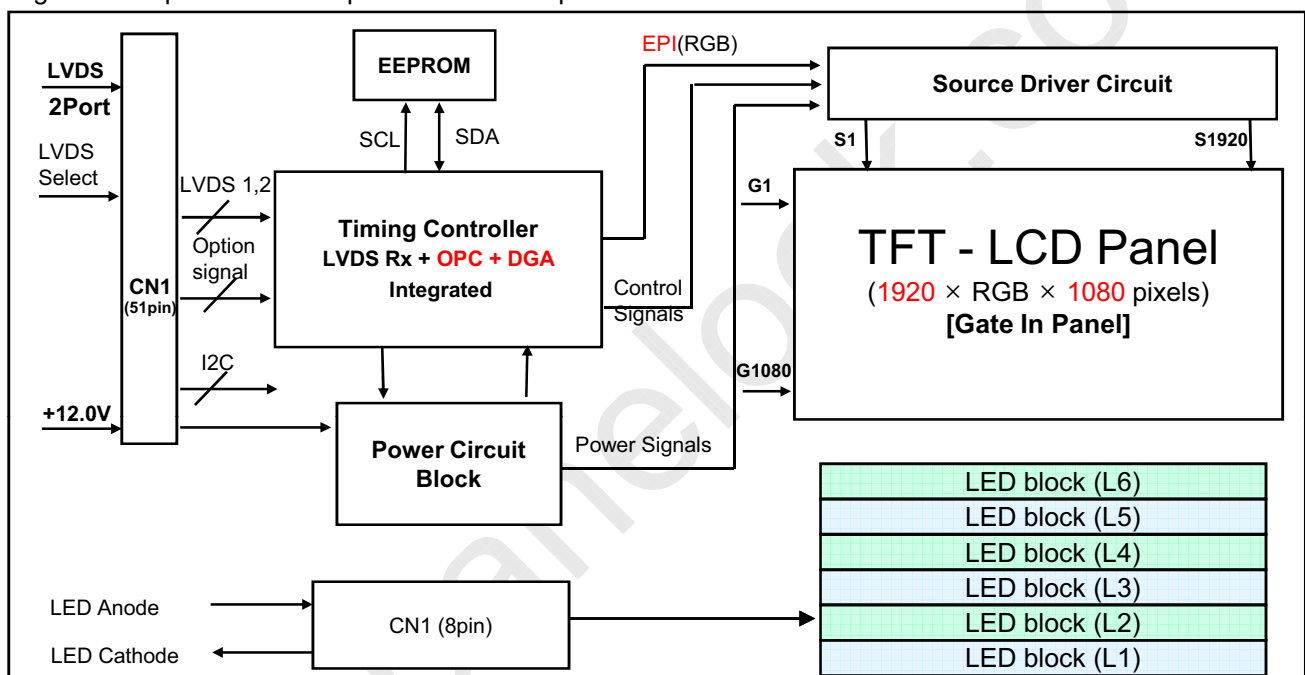

General Features

| | |
|-----------------------|---|
| Active Screen Size | 42.02 inches(1067.31mm) diagonal |
| Outline Dimension | 960.4(H) × 560.4(V) X 9.9(B)/17.4 mm(D) (Typ.) |
| Pixel Pitch | 0.4845 mm x 0.4845 mm |
| Pixel Format | 1920 horiz. by 1080 vert. Pixels, RGB stripe arrangement |
| Color Depth | 8bit, 16.7Million colors |
| Luminance, White | 400 cd/m ² (Center 1point ,Typ.) |
| Viewing Angle (CR>10) | Viewing angle free (R/L 178 (Min.), U/D 178 (Min.)) |
| Power Consumption | Total 47.3W [Logic= 6.3W(TBD), LED only = 41.0(TBD)W ((IF_cathode=105mA))] |
| Weight | 9.0 Kg (Typ.) |
| Display Mode | Transmissive mode, Normally black |
| Surface Treatment | Hard coating(3H), Anti-glare treatment of the front polarizer (Haze < 1%) |

Product Specification

2. Absolute Maximum Ratings

The following items are maximum values which, if exceeded, may cause faulty operation or permanent damage to the LCD module.

Table 1. ABSOLUTE MAXIMUM RATINGS

| Parameter | | Symbol | Value | | Unit | Note |
|--------------------------------|-----------------|--------------------|-------|----------|-----------------|------|
| | | | Min | Max | | |
| Power Input Voltage | LCD Circuit | V _{LCD} | -0.3 | +14.0 | V _{DC} | |
| LED Input Voltage | Forward Voltage | V _F | - | +81(TBD) | V _{DC} | 1 |
| T-Con Option Selection Voltage | | V _{LOGIC} | -0.3 | +4.0 | V _{DC} | |
| Operating Temperature | | T _{OP} | 0 | +50 | °C | 2,3 |
| Storage Temperature | | T _{ST} | -20 | +60 | °C | |
| Panel Front Temperature | | T _{SUR} | - | +68 | °C | 4 |
| Operating Ambient Humidity | | H _{OP} | 10 | 90 | %RH | 2,3 |
| Storage Humidity | | H _{ST} | 10 | 90 | %RH | |

Note 1. Ambient temperature condition (T_a = 25 ± 2 °C)

2. Temperature and relative humidity range are shown in the figure below.

Wet bulb temperature should be Max 39°C, and no condensation of water.

3. Gravity mura can be guaranteed below 40°C condition.

4. The maximum operating temperatures is based on the test condition that the surface temperature of display area is less than or equal to 68°C with LCD module alone in a temperature controlled chamber. Thermal management should be considered in final product design to prevent the surface temperature of display area from being over 68°C. The range of operating temperature may be degraded in case of improper thermal management in final product design.

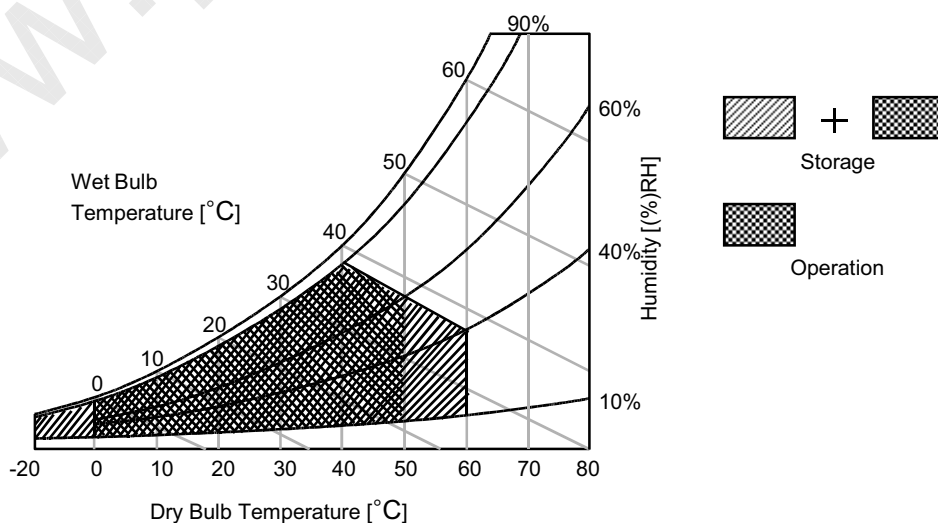

Product Specification

3. Electrical Specifications

3-1. Electrical Characteristics

It requires two power inputs. One is employed to power for the LCD circuit. The other is used for the LED backlight and LED Driver circuit.

Table 2. ELECTRICAL CHARACTERISTICS

| Parameter | Symbol | Value | | | Unit | Note |
|---------------------|-------------------|-------|------|------|------|------|
| | | Min | Typ | Max | | |
| Circuit : | | | | | | |
| Power Input Voltage | V _{LCD} | 10.8 | 12.0 | 13.2 | Vdc | |
| Power Input Current | I _{LCD} | - | 528 | 686 | mA | 1 |
| | | - | 789 | 1025 | mA | 2 |
| Power Consumption | P _{LCD} | | 6.34 | 8.24 | Watt | 1 |
| Rush current | I _{RUSH} | - | - | 3.0 | A | 3 |

- Note
1. The specified current and power consumption are under the $V_{LCD}=12.0V$, $T_a=25 \pm 2^\circ C$, $f_v=60Hz$ condition, and mosaic pattern(8 x 6) is displayed and f_v is the frame frequency.
 2. The current is specified at the maximum current pattern.
 3. The duration of rush current is about 2ms and rising time of power input is 0.5ms (min.).
 4. Ripple voltage level is recommended under $\pm 5\%$ of typical voltage

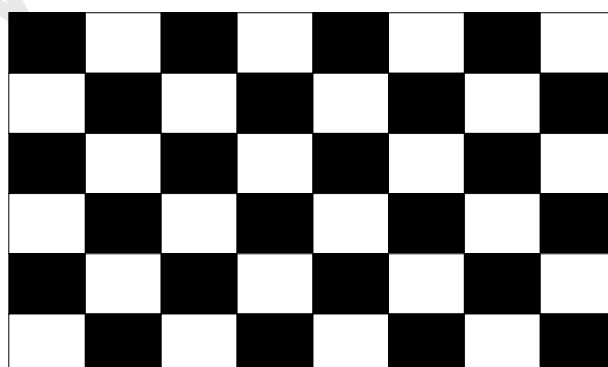
**Mosaic Pattern(8 x 6)**

White : 255 Gray
Black : 0 Gray

LC420EUE

Product Specification

Table 3. ELECTRICAL CHARACTERISTICS (Continue)

| Parameter | Symbol | Values | | | Unit | Note | |
|---------------------------------|---------|-------------------|--------|---------|-------|------|------|
| | | Min | Typ | Max | | | |
| Backlight Assembly : | | | | | | | |
| Forward Current (one array) | Anode | $I_{F (anode)}$ | | 630 | | mAdc | ±5% |
| | Cathode | $I_{F (cathode)}$ | 99.8 | 105 | 110.3 | mAdc | 2, 3 |
| Forward Voltage | | V_F | 59.0 | 65.0 | 71.0 | Vdc | 4 |
| Forward Voltage Variation | | ΔV_F | | | 1.7 | Vdc | 5 |
| Power Consumption | | P_{BL} | 37.2 | 41.0 | 44.7 | W | 6 |
| Burst Dimming Duty | | On duty | 1 | | 100 | % | |
| Burst Dimming Frequency | | 1/T | - | 100/120 | - | Hz | 8 |
| LED Array : (APPENDIX-V) | | | | | | | |
| Life Time | | | 30,000 | 50,000 | | Hrs | 7 |

Notes :The design of the LED driver must have specifications for the LED array in LCD Assembly.

The electrical characteristics of LED driver are based on Constant Current driving type.

The performance of the LED in LCM, for example life time or brightness, is extremely influenced by the characteristics of the LED Driver. So, all the parameters of an LED driver should be carefully designed.

When you design or order the LED driver, please make sure unwanted lighting caused by the mismatch of the LED and the driver (no lighting, flicker, etc) has never been occurred. When you confirm it, the LCD-Assembly should be operated in the same condition as installed in your instrument.

1. Electrical characteristics are based on LED Array specification.
2. Specified values are defined for a Backlight Assembly. (IBL :2 LED array/LCM)
3. Each LED array has one anode terminal and six cathode terminals.

The forward current(I_F) of the anode terminal is 630mA and it supplies 105mA into six strings, respectively

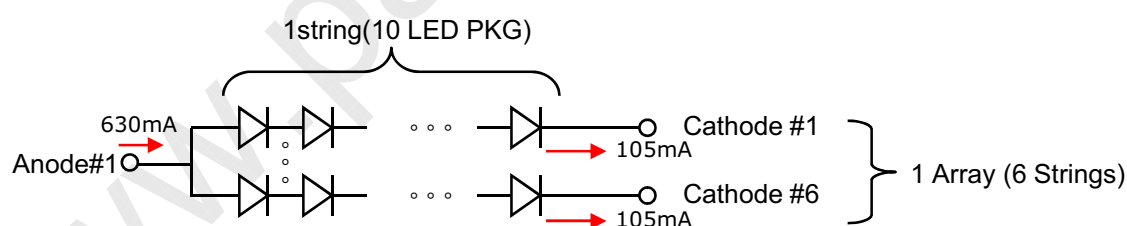

4. The forward voltage(V_F) of LED array depends on ambient temperature (Appendix-VI)
5. ΔV_F means Max V_F -Min V_F in one Backlight. So V_F variation in a Backlight isn't over Max. 1.7V
6. Maximum level of power consumption is measured at initial turn on.
Typical level of power consumption is measured after 1hrs aging at $25 \pm 2^\circ\text{C}$.
7. The life time(MTTF) is determined as the time at which brightness of the LED is 50% compared to that of initial value at the typical LED current on condition of continuous operating at $25 \pm 2^\circ\text{C}$, based on duty 100%.
8. The reference method of burst dimming duty ratio.
It is recommended to use synchronous V-sync frequency to prevent waterfall
($V_{sync} * 2 = \text{Burst Frequency}$)

Product Specification

3-2. Interface Connections

This LCD module employs three kinds of interface connection, 51-pin connector is used for the module electronics and 8-pin,8-pin connectors are used for the integral backlight system.

3-2-1. LCD Module

- LCD Connector(CN1): FI-RE51S-HF(manufactured by JAE) or IS050-C51B-C39(manufactured by UJU)
- Mating Connector : FI-R51HL(JAE) or compatible

Table 4. MODULE CONNECTOR(CN1) PIN CONFIGURATION

| No | Symbol | Description | No | Symbol | Description |
|----|-------------|-------------------------------------|----|-----------|--------------------------------------|
| 1 | NC | No Connection (Note 4) | 27 | NC | No connection |
| 2 | NC | No Connection (Note 4) | 28 | R2AN | SECOND LVDS Receiver Signal (A-) |
| 3 | NC | No Connection (Note 4) | 29 | R2AP | SECOND LVDS Receiver Signal (A+) |
| 4 | NC | No Connection (Note 4) | 30 | R2BN | SECOND LVDS Receiver Signal (B-) |
| 5 | NC | No Connection (Note 4) | 31 | R2BP | SECOND LVDS Receiver Signal (B+) |
| 6 | NC | No Connection (Note 4) | 32 | R2CN | SECOND LVDS Receiver Signal (C-) |
| 7 | LVDS Select | 'H' =JEIDA , 'L' or NC = VESA | 33 | R2CP | SECOND LVDS Receiver Signal (C+) |
| 8 | NC | No Connection (Note 4) | 34 | GND | Ground |
| 9 | NC | No Connection (Note 4) | 35 | R2CLKN | SECOND LVDS Receiver Clock Signal(-) |
| 10 | NC | No Connection (Note 4) | 36 | R2CLKP | SECOND LVDS Receiver Clock Signal(+) |
| 11 | GND | Ground | 37 | GND | Ground |
| 12 | R1AN | FIRST LVDS Receiver Signal (A-) | 38 | R2DN | SECOND LVDS Receiver Signal (D-) |
| 13 | R1AP | FIRST LVDS Receiver Signal (A+) | 39 | R2DP | SECOND LVDS Receiver Signal (D+) |
| 14 | R1BN | FIRST LVDS Receiver Signal (B-) | 40 | NC | No connection |
| 15 | R1BP | FIRST LVDS Receiver Signal (B+) | 41 | NC | No connection |
| 16 | R1CN | FIRST LVDS Receiver Signal (C-) | 42 | NC or GND | No Connection or Ground |
| 17 | R1CP | FIRST LVDS Receiver Signal (C+) | 43 | NC or GND | No Connection or Ground |
| 18 | GND | Ground | 44 | GND | Ground (Note 5) |
| 19 | R1CLKN | FIRST LVDS Receiver Clock Signal(-) | 45 | GND | Ground |
| 20 | R1CLKP | FIRST LVDS Receiver Clock Signal(+) | 46 | GND | Ground |
| 21 | GND | Ground | 47 | NC | No connection |
| 22 | R1DN | FIRST LVDS Receiver Signal (D-) | 48 | VLCD | Power Supply +12.0V |
| 23 | R1DP | FIRST LVDS Receiver Signal (D+) | 49 | VLCD | Power Supply +12.0V |
| 24 | NC | No connection | 50 | VLCD | Power Supply +12.0V |
| 25 | NC | No connection | 51 | VLCD | Power Supply +12.0V |
| 26 | NC or GND | No Connection or Ground | - | - | - |

- Note
1. All GND(ground) pins should be connected together to the LCD module's metal frame.
 2. All VLcd (power input) pins should be connected together.
 3. All Input levels of LVDS signals are based on the **EIA 644** Standard.
 4. #1~#6 & #8~#10 NC (No Connection): These pins are used only for LGD (Do not connect)
 5. Specific pin No. **#44** is used for "No signal detection" of system signal interface.
It should be GND for NSB(No Signal Black) during the system interface signal is not.
If this pin is "H", LCD Module displays AGP(Auto Generation Pattern).

LC420EUE

Product Specification

3-2-2. Backlight Module

[CN202]

- 1) LED Array assy Connector (Plug)
: HS100-L08N-N62-A (natural color, manufactured by UJU)
- 2) Mating Connector (Receptacle)
: IS100-L08T-C46-A (natural color, manufactured by UJU)

Table 5. BACKLIGHT CONNECTOR PIN CONFIGURATION(CN202)

| No | Symbol | Description | Note |
|----|------------|-----------------------------|------|
| 1 | Anode_R | LED Input Current for R1~R6 | |
| 2 | N.C | Open | |
| 3 | R6 Cathode | LED Output Current | |
| 4 | R5 Cathode | LED Output Current | |
| 5 | R4 Cathode | LED Output Current | |
| 6 | R3 Cathode | LED Output Current | |
| 7 | R2 Cathode | LED Output Current | |
| 8 | R1 Cathode | LED Output Current | |

◆ Rear view of LCM

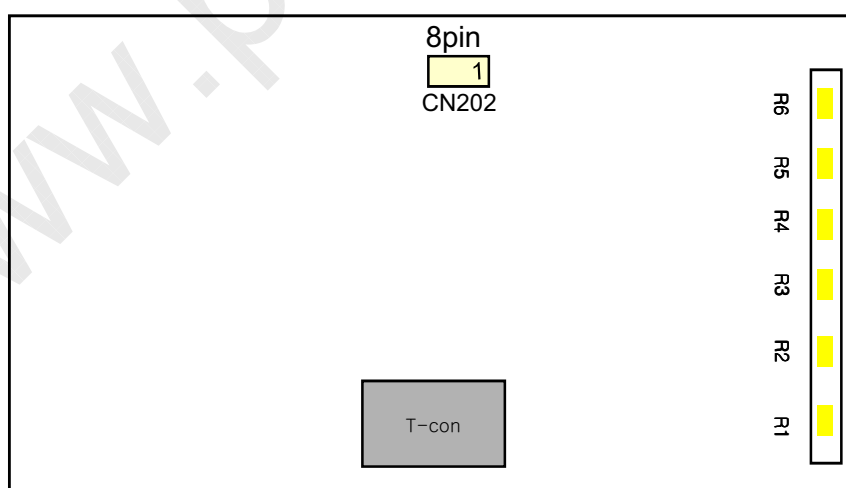

LC420EUE

Product Specification

3-3. Signal Timing Specifications

Table 6 shows the signal timing required at the input of the LVDS transmitter. All of the interface signal timings should be satisfied with the following specification for normal operation.

Table 6. TIMING TABLE (DE Only Mode)

| ITEM | | Symbol | Min | Typ | Max | Unit | Note |
|------------|----------------|--------|----------------|----------------|----------------|-------|----------|
| Horizontal | Display Period | tHV | 960 | 960 | 960 | tCLK | 1920 / 2 |
| | Blank | tHB | 100 | 140 | 240 | tCLK | 1 |
| | Total | tHP | 1060 | 1100 | 1200 | tCLK | |
| Vertical | Display Period | tVv | 1080 | 1080 | 1080 | Lines | |
| | Blank | tVB | 20 (228) | 45 (270) | 69 (300) | Lines | 1 |
| | Total | tVP | 1100 (1308) | 1125 (1350) | 1149 (1380) | Lines | |

| ITEM | | Symbol | Min | Typ | Max | Unit | Note |
|-----------|------------|--------|------------|------------|------------|------|--|
| Frequency | DCLK | fCLK | 63.00 | 74.25 | 78.00 | MHz | |
| | Horizontal | fH | 57.3 | 67.5 | 70 | KHz | 2 |
| | Vertical | fV | 57 (47) | 60 (50) | 63 (53) | Hz | 2 NTSC : 57~63Hz (PAL : 47~53Hz) |

Note: 1. The input of HSYNC & VSYNC signal does not have an effect on normal operation (DE Only Mode).
If you use spread spectrum of EMI, add some additional clock to minimum value for clock margin.

2. The performance of the electro-optical characteristics may be influenced by variance of the vertical refresh rate and the horizontal frequency

※ Timing should be set based on clock frequency.

Product Specification

3-4. LVDS Signal Specification

3-4-1. LVDS Input Signal Timing Diagram

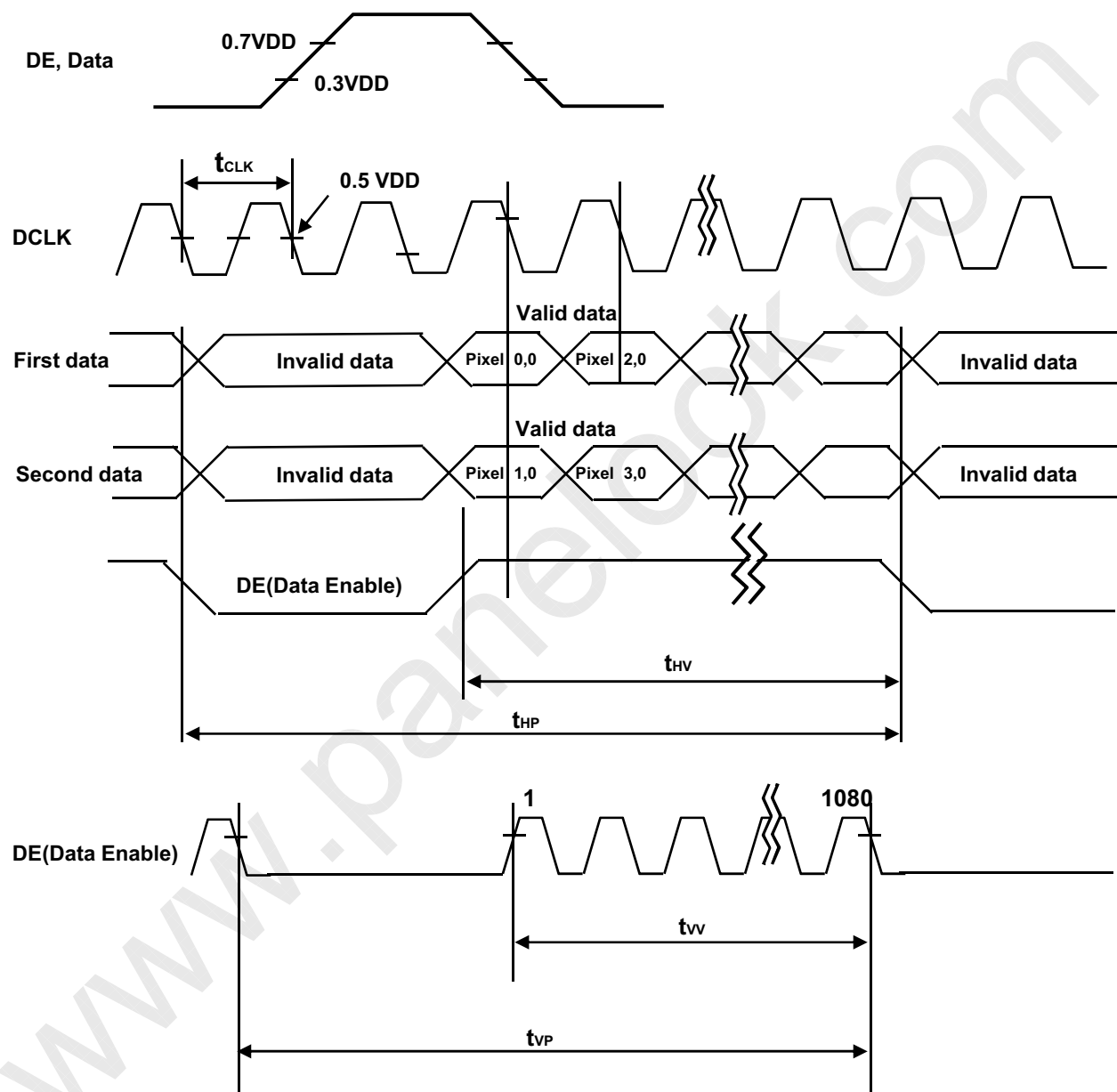

Product Specification

3-4-2. LVDS Input Signal Characteristics

1) DC Specification

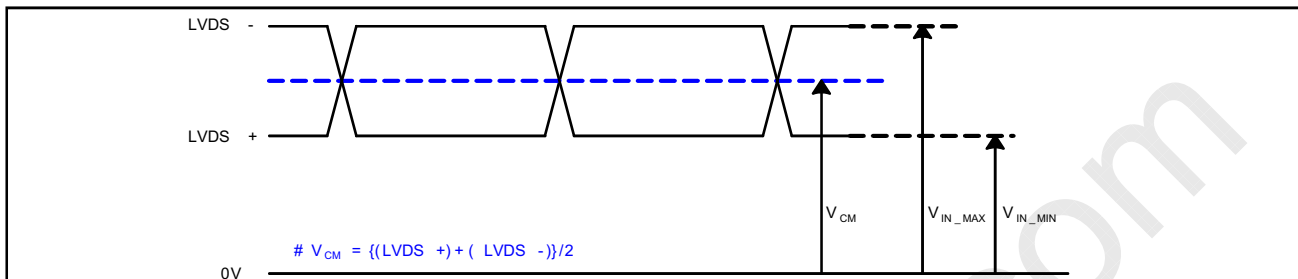

| Description | Symbol | Min | Max | Unit | Note |
|-------------------------------|-----------------|-----|-----|------|------|
| LVDS Common mode Voltage | V_{CM} | 1.0 | 1.5 | V | - |
| LVDS Input Voltage Range | V_{IN} | 0.7 | 1.8 | V | - |
| Change in common mode Voltage | ΔV_{CM} | - | 250 | mV | - |

2) AC Specification

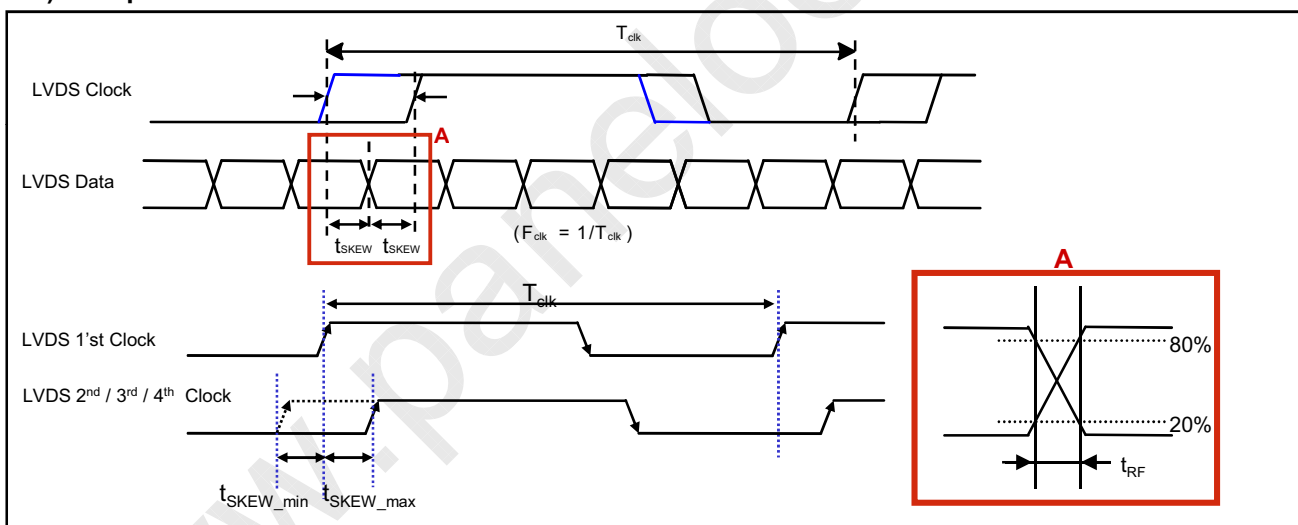

| Description | Symbol | Min | Max | Unit | Note | |
|--|----------------|-------------|-------------------------|------|------|---|
| LVDS Differential Voltage | High Threshold | V_{TH} | 100 | 600 | mV | 3 |
| | Low Threshold | V_{TL} | -600 | -100 | mV | |
| LVDS Clock to Data Skew | t_{SKEW} | - | $ (0.2 * T_{clk}) / 7 $ | ps | - | |
| LVDS Clock/DATA Rising/Falling time | t_{RF} | 260 | $ (0.3 * T_{clk}) / 7 $ | ps | 2 | |
| Effective time of LVDS | t_{eff} | $ \pm 360 $ | - | ps | - | |
| LVDS Clock to Clock Skew (Even to Odd) | t_{SKEW_EO} | - | $ 1/7 * T_{clk} $ | ps | - | |

- Note
1. All Input levels of LVDS signals are based on the EIA 644 Standard.
 2. If t_{RF} isn't enough, t_{eff} should meet the range.
 3. LVDS Differential Voltage is defined within t_{eff}

Product Specification

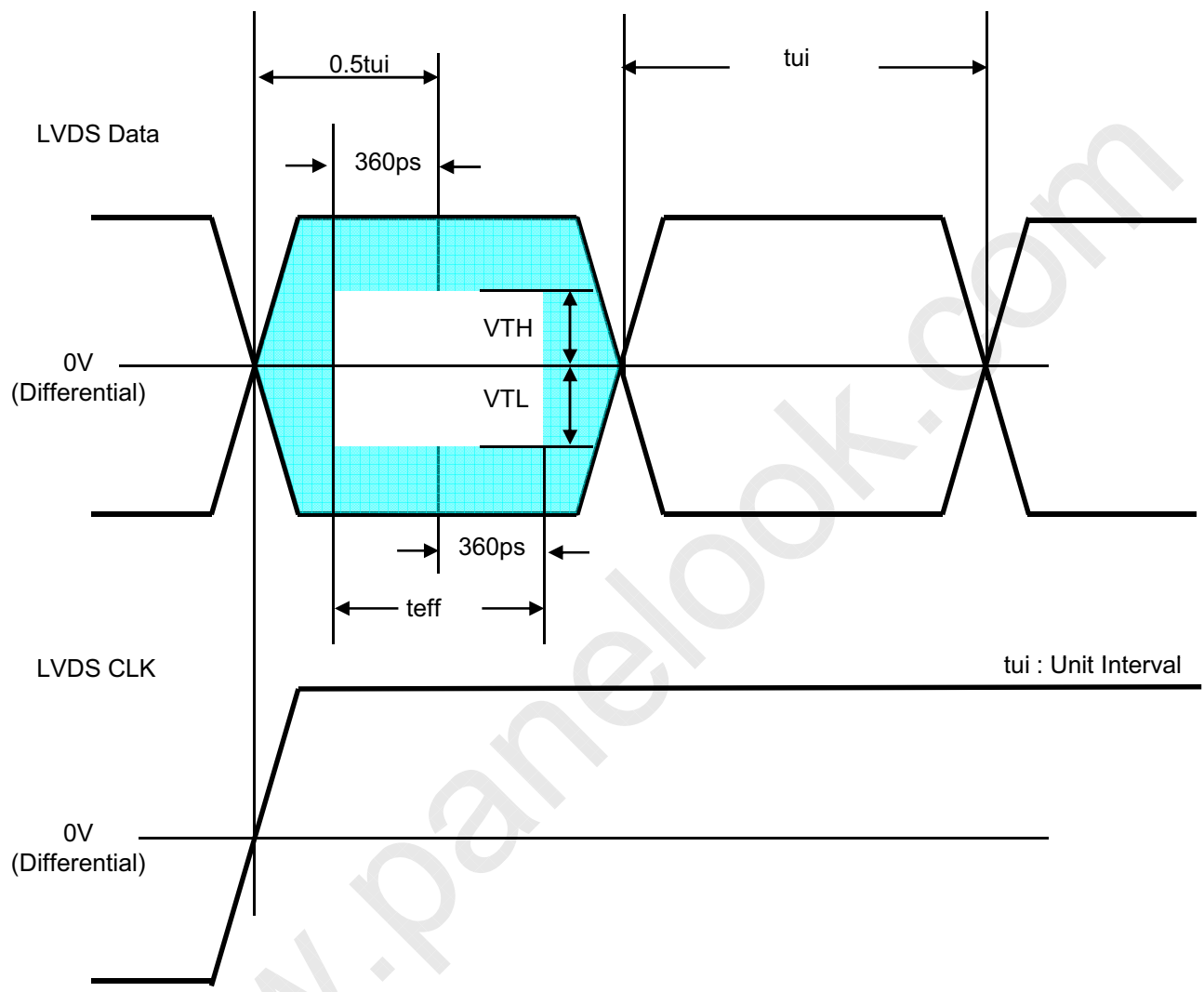

* This accumulated waveform is tested with differential probe

Product Specification

3-5. Color Data Reference

The brightness of each primary color(red,green,blue) is based on the 8bit gray scale data input for the color. The higher binary input, the brighter the color. Table 7 provides a reference for color versus data input.

Table 7. COLOR DATA REFERENCE

| Color | | Input Color Data | | | | | | | | | | | | | | | | | | | | | | | |
|-------------|-------------|------------------|----|----|----|-----|----|----|----|-------|----|----|----|-----|----|----|----|------|----|----|----|-----|----|----|----|
| | | RED | | | | | | | | GREEN | | | | | | | | BLUE | | | | | | | |
| | | MSB | | | | LSB | | | | MSB | | | | LSB | | | | MSB | | | | LSB | | | |
| | | R7 | R6 | R5 | R4 | R3 | R2 | R1 | R0 | G7 | G6 | G5 | G4 | G3 | G2 | G1 | G0 | B7 | B6 | B5 | B4 | B3 | B2 | B1 | B0 |
| Basic Color | Black | 0 | 0 | 0 | 0 | 0 | 0 | 0 | 0 | 0 | 0 | 0 | 0 | 0 | 0 | 0 | 0 | 0 | 0 | 0 | 0 | 0 | 0 | 0 | 0 |
| | Red (255) | 1 | 1 | 1 | 1 | 1 | 1 | 1 | 1 | 0 | 0 | 0 | 0 | 0 | 0 | 0 | 0 | 0 | 0 | 0 | 0 | 0 | 0 | 0 | 0 |
| | Green (255) | 0 | 0 | 0 | 0 | 0 | 0 | 0 | 0 | 1 | 1 | 1 | 1 | 1 | 1 | 1 | 1 | 0 | 0 | 0 | 0 | 0 | 0 | 0 | 0 |
| | Blue (255) | 0 | 0 | 0 | 0 | 0 | 0 | 0 | 0 | 0 | 0 | 0 | 0 | 0 | 0 | 0 | 0 | 1 | 1 | 1 | 1 | 1 | 1 | 1 | 1 |
| | Cyan | 0 | 0 | 0 | 0 | 0 | 0 | 0 | 0 | 1 | 1 | 1 | 1 | 1 | 1 | 1 | 1 | 1 | 1 | 1 | 1 | 1 | 1 | 1 | 1 |
| | Magenta | 1 | 1 | 1 | 1 | 1 | 1 | 1 | 1 | 0 | 0 | 0 | 0 | 0 | 0 | 0 | 0 | 1 | 1 | 1 | 1 | 1 | 1 | 1 | 1 |
| | Yellow | 1 | 1 | 1 | 1 | 1 | 1 | 1 | 1 | 1 | 1 | 1 | 1 | 1 | 1 | 1 | 1 | 0 | 0 | 0 | 0 | 0 | 0 | 0 | 0 |
| | White | 1 | 1 | 1 | 1 | 1 | 1 | 1 | 1 | 1 | 1 | 1 | 1 | 1 | 1 | 1 | 1 | 1 | 1 | 1 | 1 | 1 | 1 | 1 | 1 |
| RED | RED (000) | 0 | 0 | 0 | 0 | 0 | 0 | 0 | 0 | 0 | 0 | 0 | 0 | 0 | 0 | 0 | 0 | 0 | 0 | 0 | 0 | 0 | 0 | 0 | 0 |
| | RED (001) | 0 | 0 | 0 | 0 | 0 | 0 | 0 | 1 | 0 | 0 | 0 | 0 | 0 | 0 | 0 | 0 | 0 | 0 | 0 | 0 | 0 | 0 | 0 | 0 |
| | ... | ... | | | | | | | | ... | | | | | | | | ... | | | | | | | |
| | RED (254) | 1 | 1 | 1 | 1 | 1 | 1 | 1 | 0 | 0 | 0 | 0 | 0 | 0 | 0 | 0 | 0 | 0 | 0 | 0 | 0 | 0 | 0 | 0 | 0 |
| | RED (255) | 1 | 1 | 1 | 1 | 1 | 1 | 1 | 1 | 0 | 0 | 0 | 0 | 0 | 0 | 0 | 0 | 0 | 0 | 0 | 0 | 0 | 0 | 0 | 0 |
| GREEN | GREEN (000) | 0 | 0 | 0 | 0 | 0 | 0 | 0 | 0 | 0 | 0 | 0 | 0 | 0 | 0 | 0 | 0 | 0 | 0 | 0 | 0 | 0 | 0 | 0 | 0 |
| | GREEN (001) | 0 | 0 | 0 | 0 | 0 | 0 | 0 | 0 | 0 | 0 | 0 | 0 | 0 | 0 | 0 | 1 | 0 | 0 | 0 | 0 | 0 | 0 | 0 | 0 |
| | ... | ... | | | | | | | | ... | | | | | | | | ... | | | | | | | |
| | GREEN (254) | 0 | 0 | 0 | 0 | 0 | 0 | 0 | 0 | 1 | 1 | 1 | 1 | 1 | 1 | 1 | 0 | 0 | 0 | 0 | 0 | 0 | 0 | 0 | 0 |
| | GREEN (255) | 0 | 0 | 0 | 0 | 0 | 0 | 0 | 0 | 1 | 1 | 1 | 1 | 1 | 1 | 1 | 1 | 0 | 0 | 0 | 0 | 0 | 0 | 0 | 0 |
| BLUE | BLUE (000) | 0 | 0 | 0 | 0 | 0 | 0 | 0 | 0 | 0 | 0 | 0 | 0 | 0 | 0 | 0 | 0 | 0 | 0 | 0 | 0 | 0 | 0 | 0 | 0 |
| | BLUE (001) | 0 | 0 | 0 | 0 | 0 | 0 | 0 | 0 | 0 | 0 | 0 | 0 | 0 | 0 | 0 | 0 | 0 | 0 | 0 | 0 | 0 | 0 | 0 | 1 |
| | ... | ... | | | | | | | | ... | | | | | | | | ... | | | | | | | |
| | BLUE (254) | 0 | 0 | 0 | 0 | 0 | 0 | 0 | 0 | 0 | 0 | 0 | 0 | 0 | 0 | 0 | 0 | 1 | 1 | 1 | 1 | 1 | 1 | 1 | 0 |
| | BLUE (255) | 0 | 0 | 0 | 0 | 0 | 0 | 0 | 0 | 0 | 0 | 0 | 0 | 0 | 0 | 0 | 0 | 1 | 1 | 1 | 1 | 1 | 1 | 1 | 1 |

Product Specification

3-6. Power Sequence

3-6-1. LCD Driving circuit

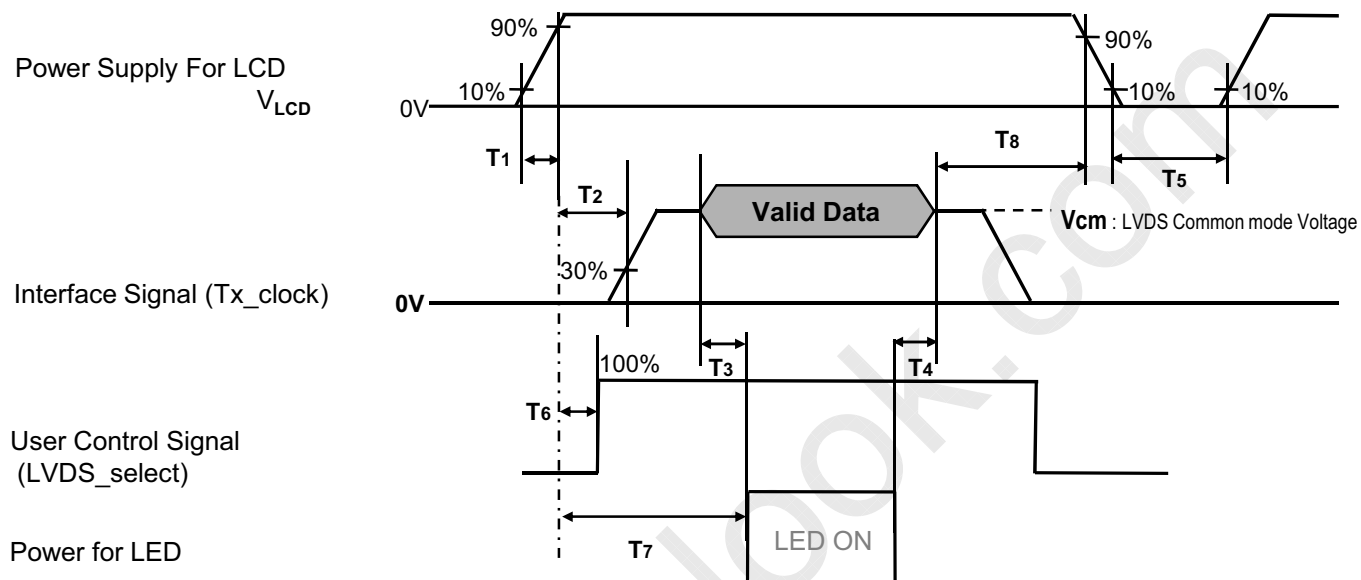

Table 8. POWER SEQUENCE

| Parameter | Value | | | Unit | Notes |
|-----------|-------|-----|-----|------|-------|
| | Min | Typ | Max | | |
| T1 | 0.5 | - | 20 | ms | 1 |
| T2 | 0 | - | - | ms | 2 |
| T3 | 200 | - | - | ms | 3 |
| T4 | 200 | - | - | ms | 3 |
| T5 | 1.0 | - | - | s | 4 |
| T6 | - | - | T2 | ms | 5 |
| T7 | 0.5 | - | - | s | 6 |
| T8 | 100 | - | - | ms | 7 |

- Note :
1. Even though T1 is over the specified value, there is no problem if I2T spec of fuse is satisfied.
 2. If T2 is satisfied with specification after removing LVDS Cable, there is no problem.
 3. The T3 / T4 is recommended value, the case when failed to meet a minimum specification, abnormal display would be shown. There is no reliability problem.
 4. T5 should be measured after the Module has been fully discharged between power off and on period.
 5. If the on time of signals (Interface signal and user control signals) precedes the on time of Power (V_{LCD}), it will be happened abnormal display. When T6 is NC status, T6 doesn't need to be measured.
 6. If there is no abnormal display, no problem.
 7. It is recommendation specification that T8 has to be 100ms as a minimum value.
- ※ Please avoid floating state of interface signal at invalid period.
 ※ When the power supply for LCD (V_{LCD}) is off, be sure to pull down the valid and invalid data to 0V.

LC420EUE

Product Specification

4. Optical Specification

Optical characteristics are determined after the unit has been 'ON' and stable in a dark environment at $25\pm 2^{\circ}\text{C}$. The values are specified at 50cm from the LCD surface at a viewing angle of Φ and θ equal to 0° .

FIG. 1 shows additional information concerning the measurement equipment and method.

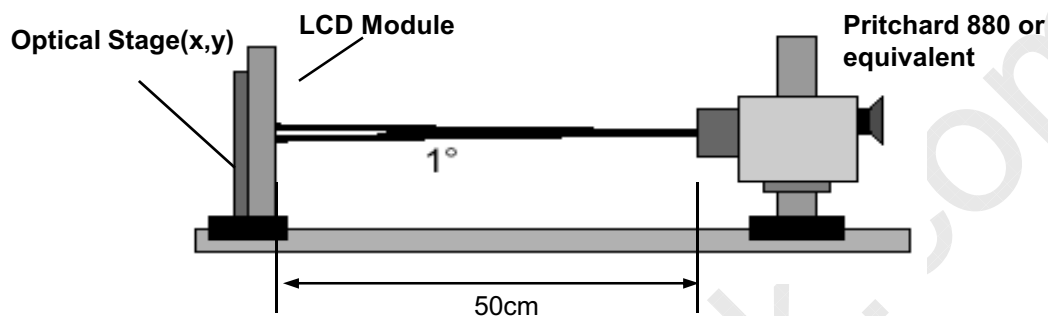

FIG. 1 Optical Characteristic Measurement Equipment and Method

$T_a = 25\pm 2^{\circ}\text{C}$, $V_{\text{LCD}} = 12.0\text{V}$, $f_v = 60\text{Hz}$, $D_{\text{clk}} = 74.25\text{MHz}$,
 $I_F = 105\text{mA}$ (Typ)

Table 10. OPTICAL CHARACTERISTICS

| Parameter | Symbol | Value | | | Unit | Note | |
|--------------------------------|-------------------------------------|----------------------|--------------|-------|-------------------|--------|---|
| | | Min | Typ | Max | | | |
| Contrast Ratio | CR | 1000 | 1400 | - | | 1 | |
| Surface Luminance, white | L_{WH} | 320 | 400 | - | cd/m ² | 2 | |
| Luminance Variation | δ_{WHITE} 5P | - | - | 1.3 | | 3 | |
| Response Time | Variation G to G _σ | | 6 | 9 | | 5 | |
| | Gray to Gray (BW) | G to G _{BW} | | 8 | 12 | ms | 4 |
| Color Coordinates [CIE1931] | RED | R _x | Typ -0.03 | 0.635 | Typ +0.03 | | |
| | | R _y | | 0.341 | | | |
| | GREEN | G _x | | 0.320 | | | |
| | | G _y | | 0.598 | | | |
| | BLUE | B _x | | 0.154 | | | |
| | | B _y | | 0.048 | | | |
| | WHITE | W _x | | 0.279 | | | |
| W _y | | 0.292 | | | | | |
| Color Temperature | | | 10,000 | | K | | |
| Color Gamut | | | 68 | | % | | |
| Viewing Angle (CR>10) | | | | | | | |
| | x axis, right ($\phi=0^{\circ}$) | θ_r | 89 | - | - | degree | 6 |
| | x axis, left ($\phi=180^{\circ}$) | θ_l | 89 | - | - | | |
| | y axis, up ($\phi=90^{\circ}$) | θ_u | 89 | - | - | | |
| | y axis, down ($\phi=270^{\circ}$) | θ_d | 89 | - | - | | |
| Gray Scale | | | - | - | - | | 7 |

Product Specification

Note : 1. Contrast Ratio(CR) is defined mathematically as :

$$CR(\text{Contrast Ratio}) = \text{Maximum CR}_n (n=1, 2, 3, 4, 5)$$

$$CR_n = \frac{\text{Surface Luminance at position } n \text{ with all white pixels}}{\text{Surface Luminance at position } n \text{ with all black pixels}}$$

n = the Position number(1, 2, 3, 4, 5). For more information, see FIG 2.

2. Surface luminance are determined after the unit has been 'ON' and 1 Hour after lighting the backlight in a dark environment at $25 \pm 2^\circ\text{C}$. Surface luminance is the luminance value at center 1-point across the LCD surface 50cm from the surface with all pixels displaying white. For more information see the FIG. 2.

3. The variation in surface luminance, δ WHITE is defined as :

$$\delta \text{ WHITE}(5P) = \text{Maximum}(L_{on1}, L_{on2}, L_{on3}, L_{on4}, L_{on5}) / \text{Minimum}(L_{on1}, L_{on2}, L_{on3}, L_{on4}, L_{on5})$$

Where L_{on1} to L_{on5} are the luminance with all pixels displaying white at 5 locations .

For more information, see the FIG. 2.

4. Response time is the time required for the display to transit from any gray to white (Rise Time, Tr_R) and from any gray to black (Decay time, Tr_D). For additional information see the FIG. 3.

* G to G_{BW} Spec stands for average value of all measured points.

Photo Detector : RD-80S / Field : 2°

5. G to G_σ is Variation of Gray to Gray response time composing a picture

$$G \text{ to } G(\sigma) = \sqrt{\frac{\sum(X_i - u)^2}{N}} \quad \begin{array}{l} X_i = \text{Individual Data} \\ u = \text{Data average} \\ N : \text{The number of Data} \end{array}$$

6. Viewing angle is the angle at which the contrast ratio is greater than 10. The angles are determined for the horizontal or x axis and the vertical or y axis with respect to the z axis which is normal to the LCD module surface. For more information, see the FIG. 4.

7. Gray scale specification

Gamma Value is approximately 2.2. For more information, see the Table 11.

Table 11. GRAY SCALE SPECIFICATION

| Gray Level | Luminance [%] (Typ) |
|------------|---------------------|
| L0 | 0.07 |
| L15 | 0.27 |
| L31 | 1.04 |
| L47 | 2.49 |
| L63 | 4.68 |
| L79 | 7.66 |
| L95 | 11.5 |
| L111 | 16.1 |
| L127 | 21.6 |
| L143 | 28.1 |
| L159 | 35.4 |
| L175 | 43.7 |
| L191 | 53.0 |
| L207 | 63.2 |
| L223 | 74.5 |
| L239 | 86.7 |
| L255 | 100 |

LC420EUE

Product Specification

Measuring point for surface luminance & measuring point for luminance variation.

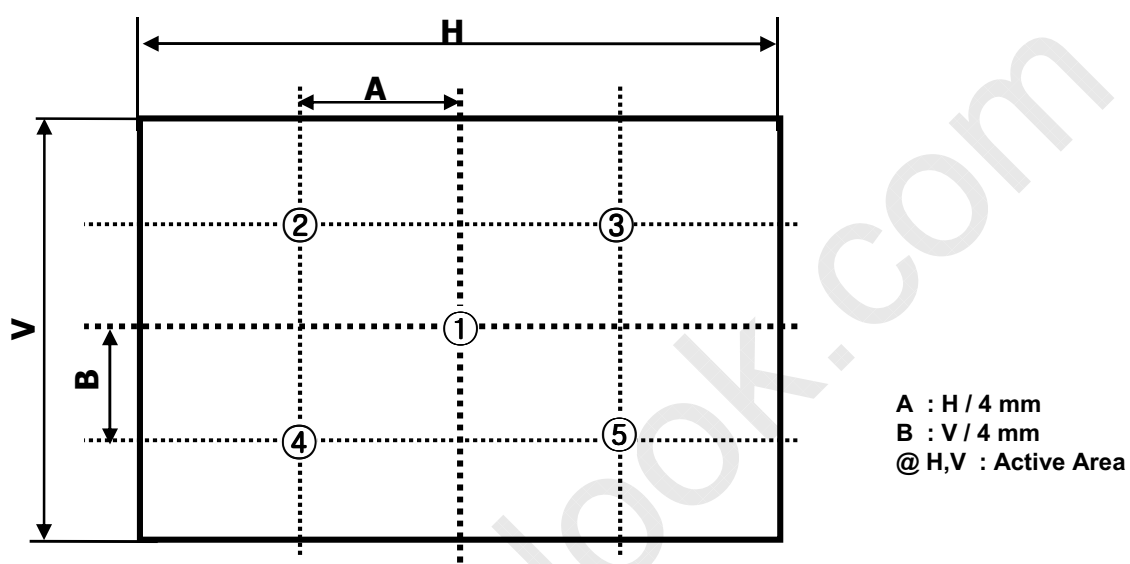

FIG. 2 5 Points for Luminance Measure

Response time is defined as the following figure and shall be measured by switching the input signal for "Gray(N)" and "Gray(M)".

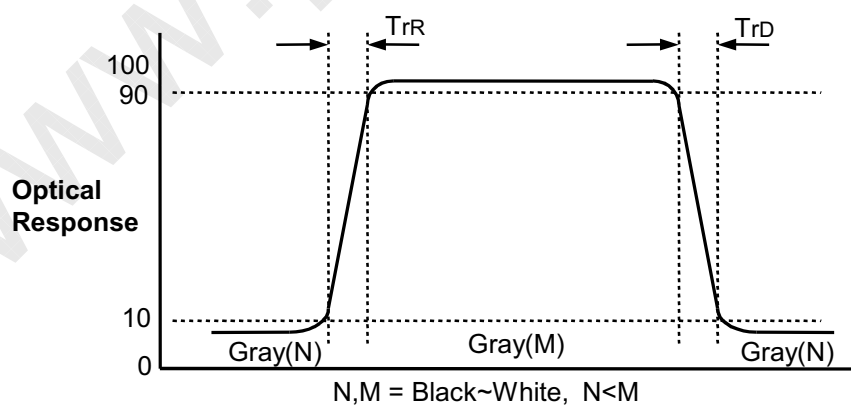

FIG. 3 Response Time

LC420EUE

Product Specification

Dimension of viewing angle range

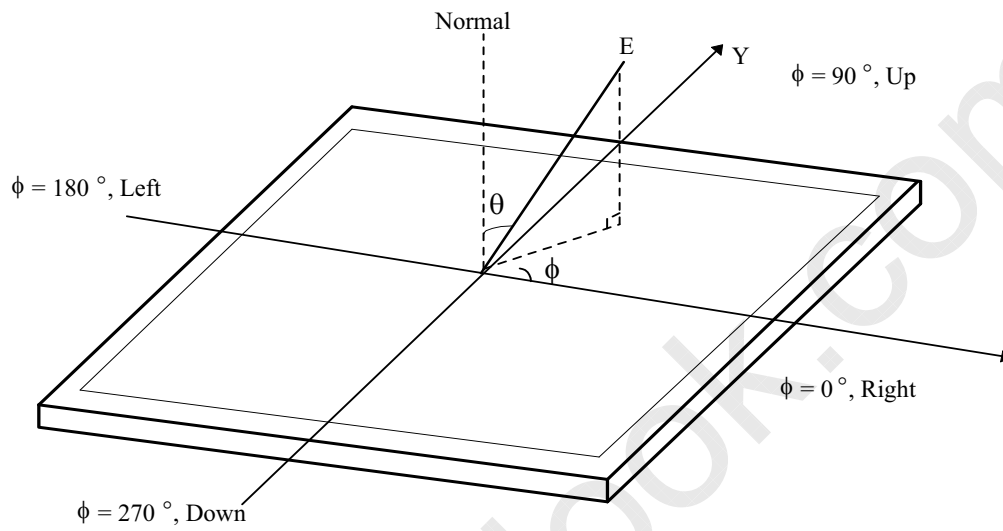

FIG. 4 Viewing Angle

Product Specification

5. Mechanical Characteristics

Table 12 provides general mechanical characteristics.

Table 12. MECHANICAL CHARACTERISTICS

| Item | Value | |
|---------------------|------------------------------|-----------|
| Outline Dimension | Horizontal | 960.4 mm |
| | Vertical | 560.4 mm |
| | Depth | 9.9 mm |
| Bezel Area | Horizontal | 938.6 mm |
| | Vertical | 531.5 mm |
| Active Display Area | Horizontal | 930.24 mm |
| | Vertical | 523.26 mm |
| Weight | 9.0 Kg (Typ.), 9.5 kg (Max.) | |

Note : Please refer to a mechanical drawing in terms of tolerance at the next page.

LC420EUE

Product Specification

[FRONT VIEW_TBD]

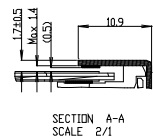
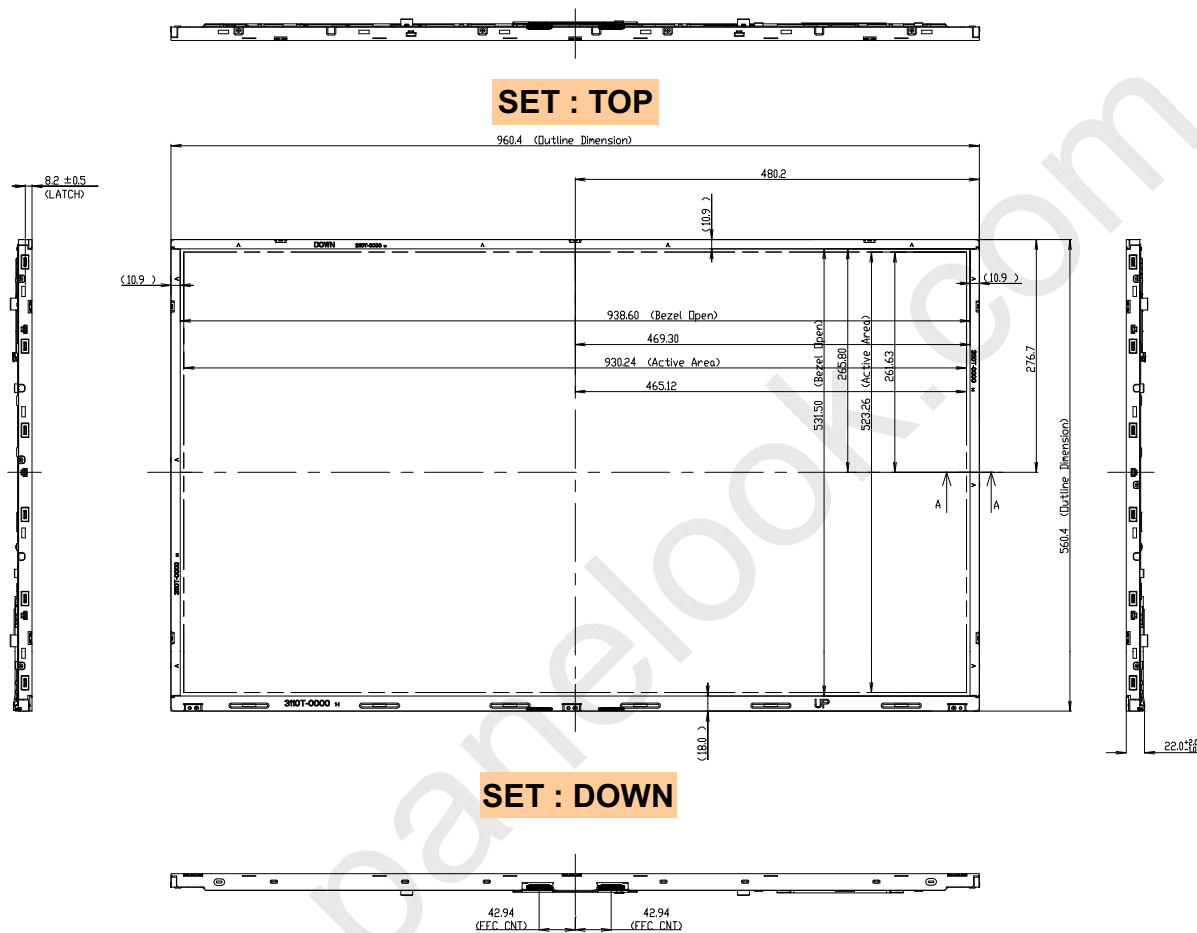

- NOTES
1. UNSPECIFIED TOLERANCE IS ±1.0MM
 2. TILT AND PARTIAL DISPOSITION TOLERANCE OF DISPLAY AREA AS FOLLOWING.
 - (1) Y-DIRECTION: | A-B | ≤ 1.6
 - (2) X-DIRECTION: | C-D | ≤ 1.6
 3. Screw Head Max Protrusion : <X>1.0MM
 4. Screw Max Protrusion : <Y>1.8MM, <Z>2.5MM

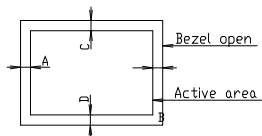

LC420EUE

Product Specification

[REAR VIEW_TBD]

SET : TOP

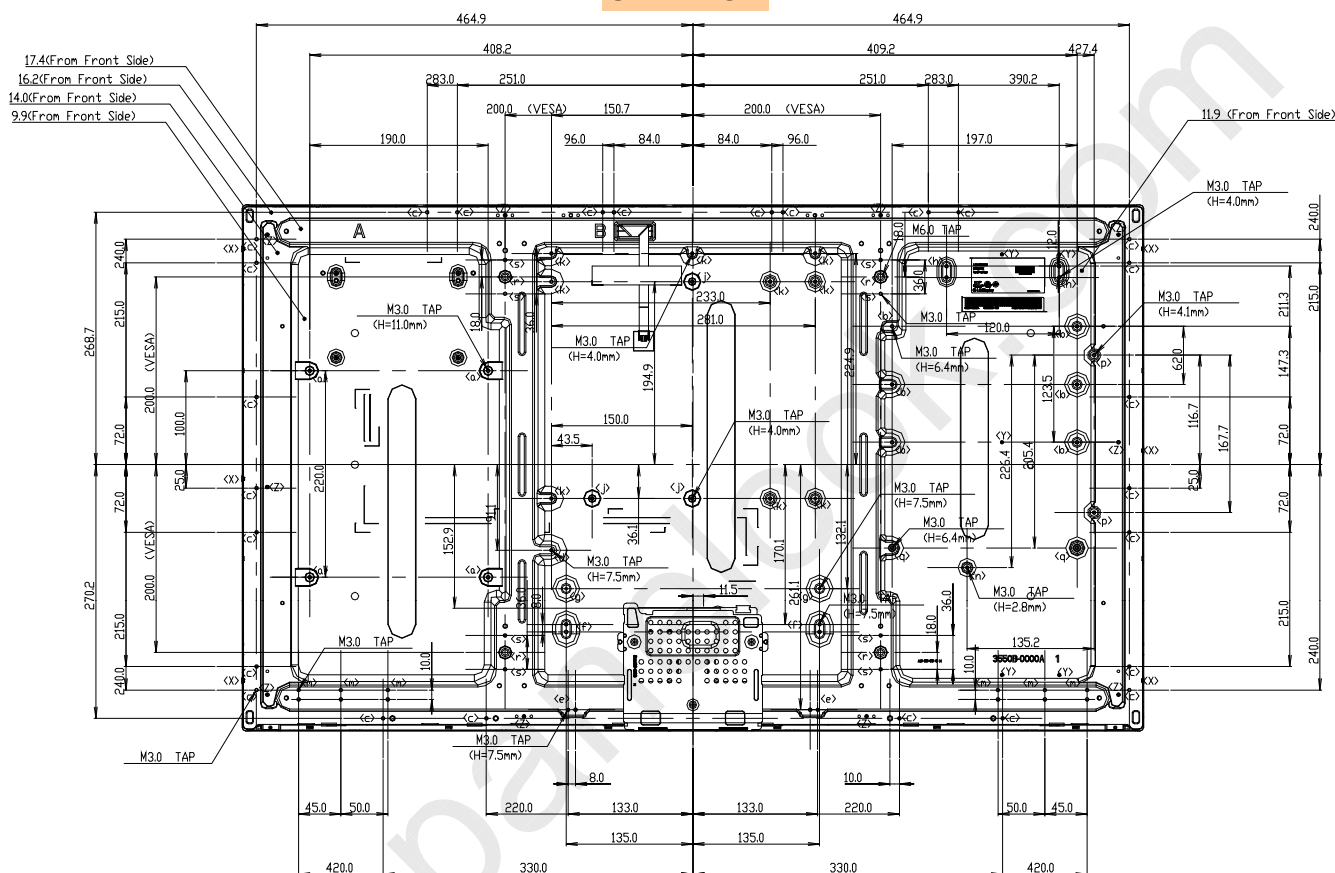

SET : DOWN

| ITEM | TAP | UDM Height (mm) | Max Depth (mm) | Torque (Kg.f.cm) | Notes |
|------|-----|-----------------|----------------|------------------|-------|
| <a> | M3 | 11.0 | MAX 10.0 | MAX 8.0 | |
| | M3 | 6.4 | MAX 6.0 | MAX 8.0 | |
| <c> | M3 | - | MAX 5.0 | MAX 8.0 | |
| <d> | M3 | 7.5 | MAX 7.0 | MAX 8.0 | |
| <e> | M3 | 7.5 | MAX 7.0 | MAX 8.0 | |
| <f> | M3 | 7.5 | MAX 7.0 | MAX 8.0 | |
| <g> | M3 | 7.5 | MAX 7.0 | MAX 8.0 | |
| <h> | M3 | 4.0 | MAX 3.5 | MAX 8.0 | |
| <j> | M3 | 4.0 | MAX 4.5 | MAX 8.0 | |
| <k> | M3 | 4.0 | MAX 4.5 | MAX 8.0 | |
| <n> | M3 | - | MAX 7.0 | MAX 8.0 | |
| <n> | M3 | 2.8 | MAX 4.0 | MAX 8.0 | |
| <p> | M3 | 4.1 | MAX 3.5 | MAX 8.0 | |
| <q> | M3 | 6.4 | MAX 6.0 | MAX 8.0 | |
| <r> | M6 | 8.3 | MAX 12.0 | | |
| <s> | M3 | - | MAX 7.0 | MAX 8.0 | |

LC420EUE

Product Specification

6. Reliability

Table 13. ENVIRONMENT TEST CONDITION

| No. | Test Item | Condition |
|-----|--|---|
| 1 | High temperature storage test | Ta= 60°C 240h |
| 2 | Low temperature storage test | Ta= -20°C 240h |
| 3 | High temperature operation test | Ta= 50°C 50%RH 240h |
| 4 | Low temperature operation test | Ta= 0°C 240h |
| 5 | Vibration test (non-operating) | Wave form : random Vibration level : 1.0Grms Bandwidth : 10-300Hz Duration : X,Y,Z, Each direction per 10 min |
| 6 | Shock test (non-operating) | Shock level : 50Grms Waveform : half sine wave, 11ms Direction : ±X, ±Y, ±Z One time each direction |
| 7 | Humidity condition Operation | Ta= 40 °C ,90%RH |
| 8 | Altitude operating storage / shipment | 0 - 15,000 ft 0 - 40,000 ft |

Note : Before and after Reliability test, LCM should be operated with normal function.

Product Specification

7. International Standards

7-1. Safety

- a) UL 60065, Seventh Edition, Underwriters Laboratories Inc.
Audio, Video and Similar Electronic Apparatus - Safety Requirements.
- b) CAN/CSA C22.2 No.60065:03, Canadian Standards Association.
Audio, Video and Similar Electronic Apparatus - Safety Requirements.
- c) EN 60065:2002 + A11:2008, European Committee for Electrotechnical Standardization (CENELEC).
Audio, Video and Similar Electronic Apparatus - Safety Requirements.
- d) IEC 60065:2005 + A1:2005, The International Electrotechnical Commission (IEC).
Audio, Video and Similar Electronic Apparatus - Safety Requirements.
(Including report of IEC60825-1:2001 clause 8 and clause 9)

Notes

1. Laser (LED Backlight) Information

| |
|---|
| Class 1M LED Product IEC60825-1 : 2001 Embedded LED Power (Class 1) |
|---|

2. Caution

: LED inside.

Class 1 laser (LEDs) radiation when open.

Do not open while operating.

7-2. EMC

- a) ANSI C63.4 "American National Standard for Methods of Measurement of Radio-Noise Emissions from Low-Voltage Electrical and Electronic Equipment in the Range of 9 kHz to 40 GHz." American National Standards Institute (ANSI), 2003.
- b) CISPR 22 "Information technology equipment – Radio disturbance characteristics – Limit and methods of measurement." International Special Committee on Radio Interference (CISPR), 2005.
- c) CISPR 13 "Sound and television broadcast receivers and associated equipment – Radio disturbance characteristics – Limits and method of measurement." International Special Committee on Radio Interference (CISPR), 2006.

7-3. Environment

- a) RoHS, Directive 2002/95/EC of the European Parliament and of the council of 27 January 2003

LC420EUE

Product Specification

8. Packing

8-1. Information of LCM Label

a) Lot Mark

| | | | | | | | | | | | | |
|---|---|---|---|---|---|---|---|---|---|---|---|---|
| A | B | C | D | E | F | G | H | I | J | K | L | M |
|---|---|---|---|---|---|---|---|---|---|---|---|---|

A,B,C : SIZE(INCH)
E : MONTH

D : YEAR
F ~ M : SERIAL NO.

Note

1. YEAR

| | | | | | | | | | | |
|------|------|------|------|------|------|------|------|------|------|------|
| Year | 2011 | 2012 | 2013 | 2014 | 2015 | 2016 | 2017 | 2018 | 2019 | 2020 |
| Mark | A | B | C | D | E | F | G | H | J | K |

2. MONTH

| | | | | | | | | | | | | |
|-------|-----|-----|-----|-----|-----|-----|-----|-----|-----|-----|-----|-----|
| Month | Jan | Feb | Mar | Apr | May | Jun | Jul | Aug | Sep | Oct | Nov | Dec |
| Mark | 1 | 2 | 3 | 4 | 5 | 6 | 7 | 8 | 9 | A | B | C |

b) Location of Lot Mark

Serial NO. is printed on the label. The label is attached to the backside of the LCD module.
This is subject to change without prior notice.

8-2. Packing Form

a) Package quantity in one Pallet : 16 pcs

b) Pallet Size : 1140 mm(W) X 990 mm(D) X 782 mm(H)

Product Specification

9. Precautions

Please pay attention to the followings when you use this TFT LCD module.

9-1. Mounting Precautions

- (1) You must mount a module using specified mounting holes (Details refer to the drawings).
- (2) You should consider the mounting structure so that uneven force (ex. Twisted stress) is not applied to the module. And the case on which a module is mounted should have sufficient strength so that external force is not transmitted directly to the module.
- (3) Please attach the surface transparent protective plate to the surface in order to protect the polarizer. Transparent protective plate should have sufficient strength in order to resist external force.
- (4) You should adopt radiation structure to satisfy the temperature specification.
- (5) Acetic acid type and chlorine type materials for the cover case are not desirable because the former generates corrosive gas of attacking the polarizer at high temperature and the latter causes circuit break by electro-chemical reaction.
- (6) Do not touch, push or rub the exposed polarizers with glass, tweezers or anything harder than HB pencil lead. And please do not rub with dust clothes with chemical treatment. Do not touch the surface of polarizer for bare hand or greasy cloth. (Some cosmetics are detrimental to the polarizer.)
- (7) When the surface becomes dusty, please wipe gently with absorbent cotton or other soft materials like chamois soaks with petroleum benzine. Normal-hexane is recommended for cleaning the adhesives used to attach front / rear polarizers. Do not use acetone, toluene and alcohol because they cause chemical damage to the polarizer.
- (8) Wipe off saliva or water drops as soon as possible. Their long time contact with polarizer causes deformations and color fading.
- (9) Do not open the case because inside circuits do not have sufficient strength.

9-2. Operating Precautions

- (1) The spike noise causes the mis-operation of circuits. It should be lower than following voltage :
 $V = \pm 200\text{mV}$ (Over and under shoot voltage)
- (2) Response time depends on the temperature. (In lower temperature, it becomes longer.)
- (3) Brightness depends on the temperature. (In lower temperature, it becomes lower.)
And in lower temperature, response time (required time that brightness is stable after turned on) becomes longer
- (4) Be careful for condensation at sudden temperature change. Condensation makes damage to polarizer or electrical contacted parts. And after fading condensation, smear or spot will occur.
- (5) When fixed patterns are displayed for a long time, remnant image is likely to occur.
- (6) Module has high frequency circuits. Sufficient suppression to the electromagnetic interference shall be done by system manufacturers. Grounding and shielding methods may be important to minimize the interference.
- (7) Please do not give any mechanical and/or acoustical impact to LCM. Otherwise, LCM can't be operated its full characteristics perfectly.
- (8) A screw which is fastened up the steels should be a machine screw.
(if not, it can cause conductive particles and deal LCM a fatal blow)
- (9) Please do not set LCD on its edge.
- (10) The conductive material and signal cables are kept away from LED driver inductor to prevent abnormal display, sound noise and temperature rising.

Product Specification

9-3. Electrostatic Discharge Control

Since a module is composed of electronic circuits, it is not strong to electrostatic discharge. Make certain that treatment persons are connected to ground through wrist band etc. And don't touch interface pin directly.

9-4. Precautions for Strong Light Exposure

Strong light exposure causes degradation of polarizer and color filter.

9-5. Storage

When storing modules as spares for a long time, the following precautions are necessary.

- (1) Store them in a dark place. Do not expose the module to sunlight or fluorescent light. Keep the temperature between 5°C and 35°C at normal humidity.
- (2) The polarizer surface should not come in contact with any other object.
It is recommended that they be stored in the container in which they were shipped.
- (3) Storage condition is guaranteed under packing conditions.
- (4) The phase transition of Liquid Crystal in the condition of the low or high storage temperature will be recovered when the LCD module returns to the normal condition.

9-6. Handling Precautions for Protection Film

- (1) The protection film is attached to the bezel with a small masking tape.
When the protection film is peeled off, static electricity is generated between the film and polarizer.
This should be peeled off slowly and carefully by people who are electrically grounded and with well ion-blown equipment or in such a condition, etc.
- (2) When the module with protection film attached is stored for a long time, sometimes there remains a very small amount of glue still on the bezel after the protection film is peeled off.
- (3) You can remove the glue easily. When the glue remains on the bezel surface or its vestige is recognized, please wipe them off with absorbent cotton waste or other soft material like chamois soaked with normal-hexane.

LC420EUE

Product Specification

APPENDIX-I

■ Pallet Ass'y

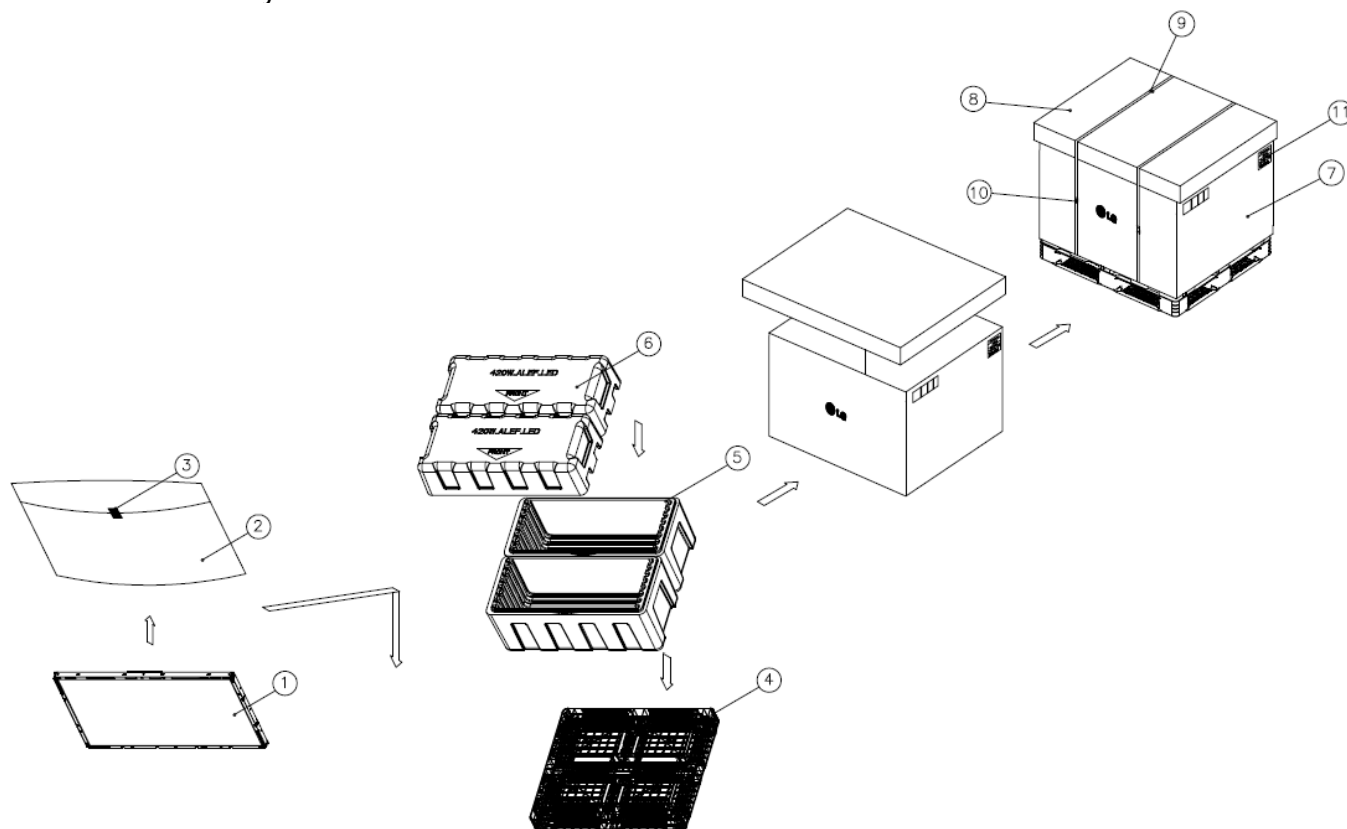

| NO. | DESCRIPTION | MATERIAL |
|-----|----------------|------------------------|
| 1 | LCD Module | |
| 2 | BAG | 42INCH |
| 3 | TAPE | MASKING 20MMX50M |
| 4 | PALLET | Plastic 1140X990X120mm |
| 5 | PACKING,BOTTOM | EPS |
| 6 | PACKING, TOP | EPS |
| 7 | ANGLE,PACKING | PAPER |
| 8 | BAND | PP |
| 9 | ANGLE.COVER | PAPER |
| 10 | BAND,CLIP | STEEL or PP |
| 11 | LABEL | YUPO 80G 100X70 |

LC420EUE

Product Specification

APPENDIX- II-1

■ LCM Label

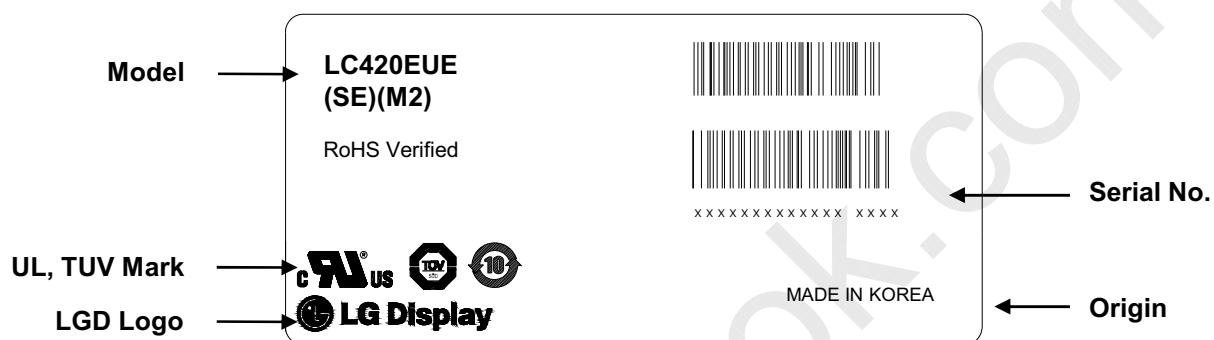

LC420EUE

Product Specification

APPENDIX- II-2

■ Pallet Label

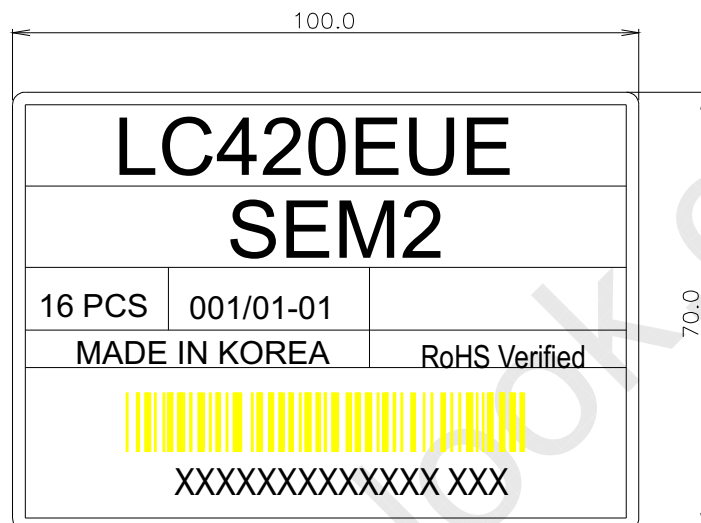

Product Specification

APPENDIX- III-1

■ Required signal assignment for Flat Link (Thine : THC63LVD103) Transmitter(Pin7= "L" or "NC")

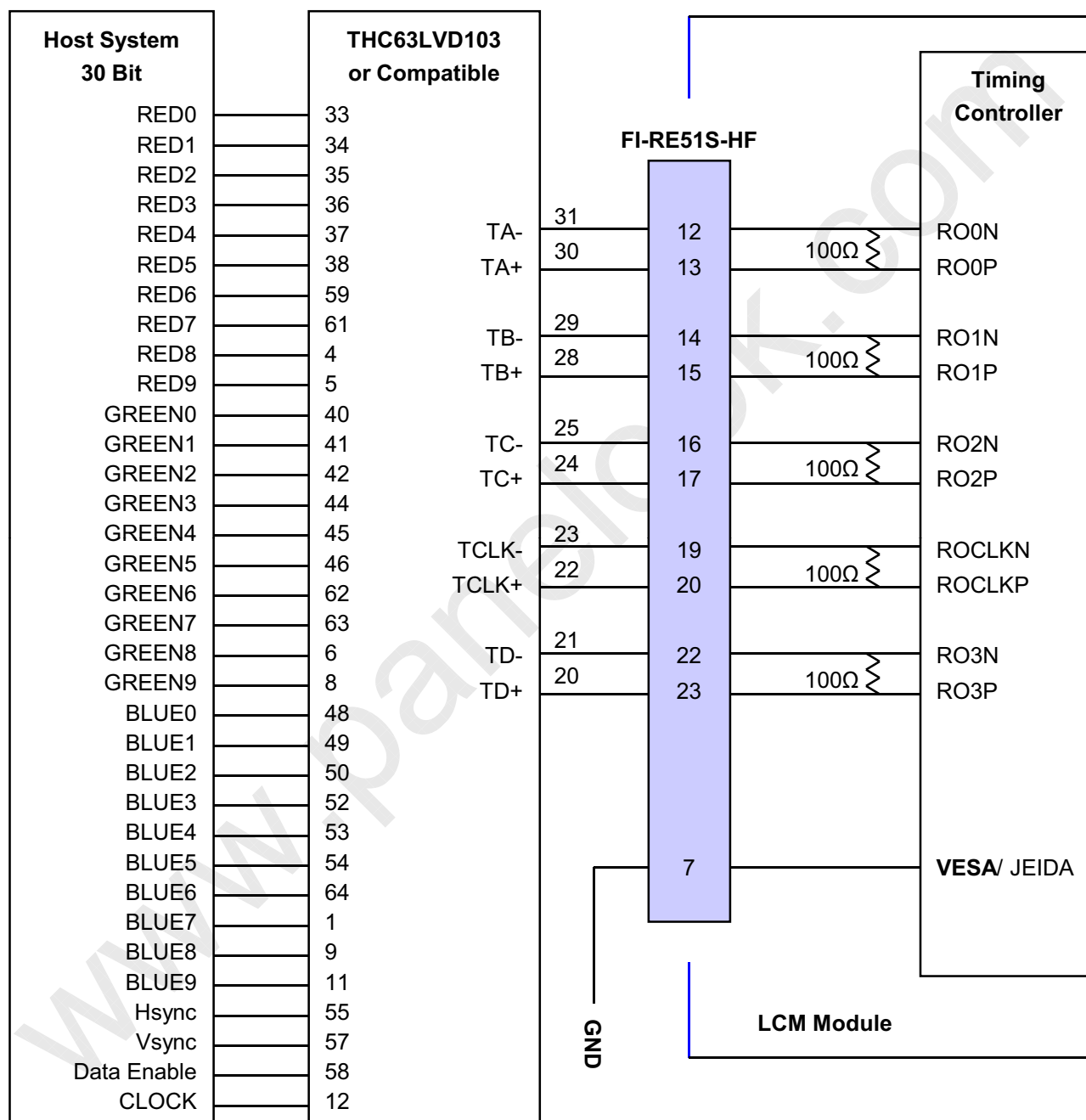

Note: 1. The LCD module uses a 100 Ohm[Ω] resistor between positive and negative lines of each receiver input.

2. Refer to LVDS Transmitter Data Sheet for detail descriptions. (THC63LVD103 or Compatible)

3. '7' means MSB and '0' means LSB at R,G,B pixel data.

Product Specification

APPENDIX- III-2

■ Required signal assignment for Flat Link (Thine : THC63LVD103) Transmitter(Pin7= "H")

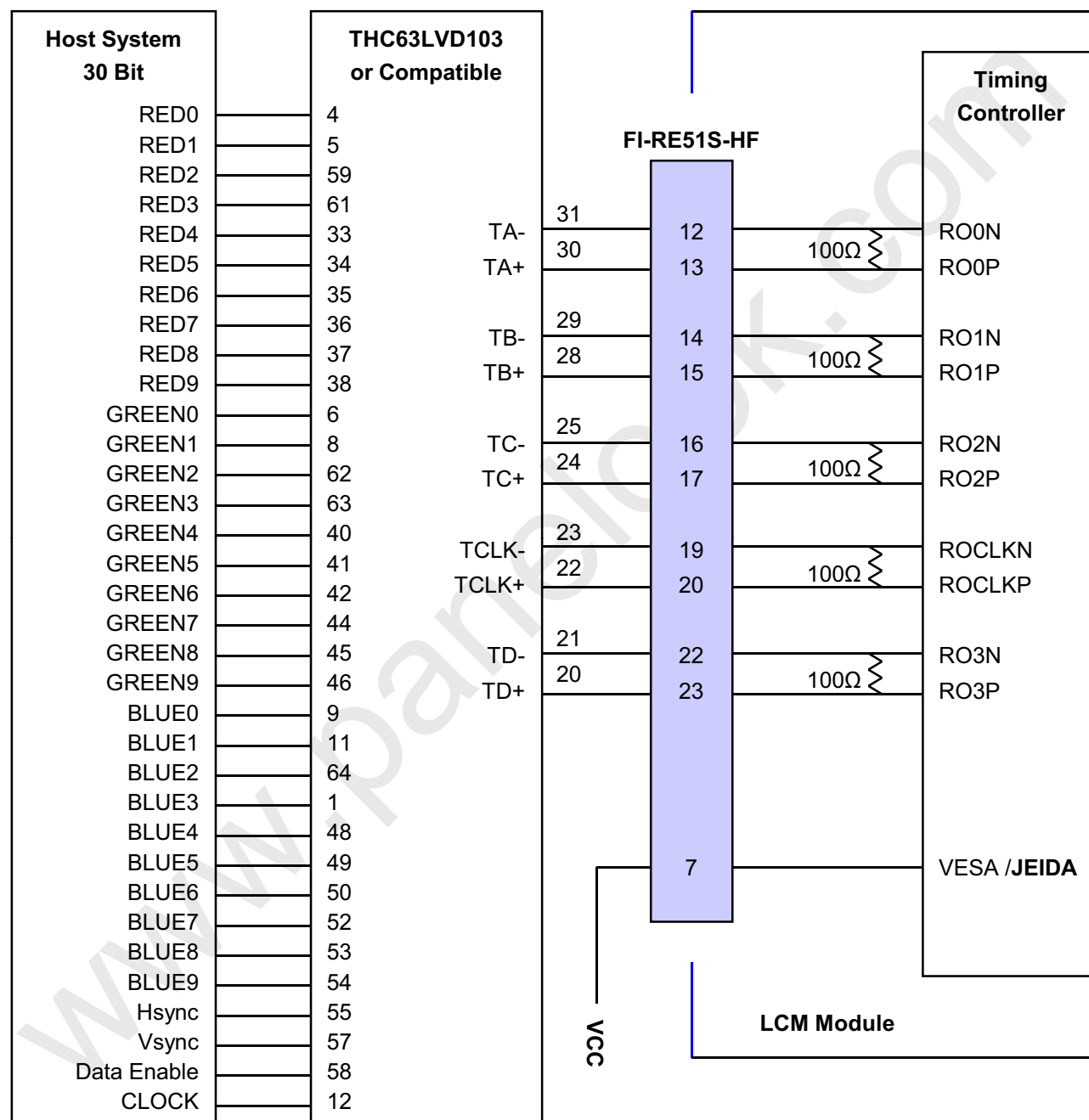

Note :1. The LCD module uses a 100 Ohm[Ω] resistor between positive and negative lines of each receiver input.

2. Refer to LVDS Transmitter Data Sheet for detail descriptions. (THC63LVD103 or Compatible)

3. '7' means MSB and '0' means LSB at R,G,B pixel data.

Product Specification

APPENDIX- IV

■ LVDS Data-Mapping Information (8 Bit)

1) LVDS Select : "H" Data-Mapping (JEIDA format)

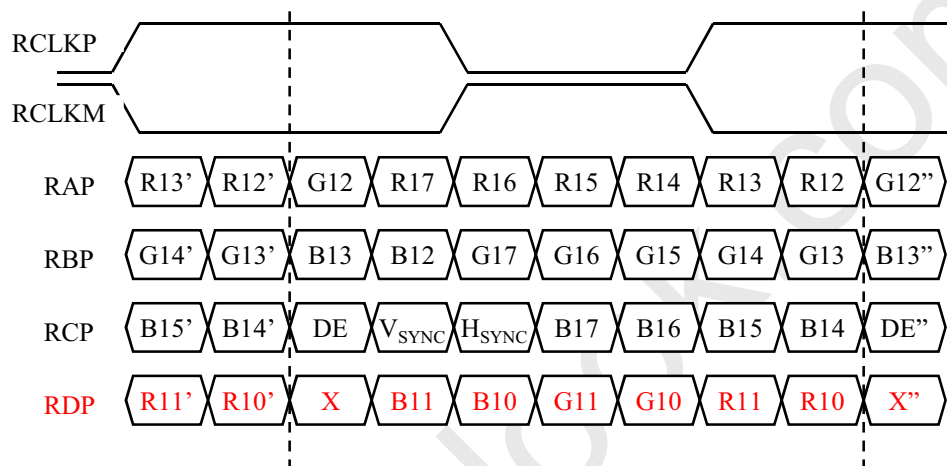

2) LVDS Select : "L" Data-Mapping (VESA format)

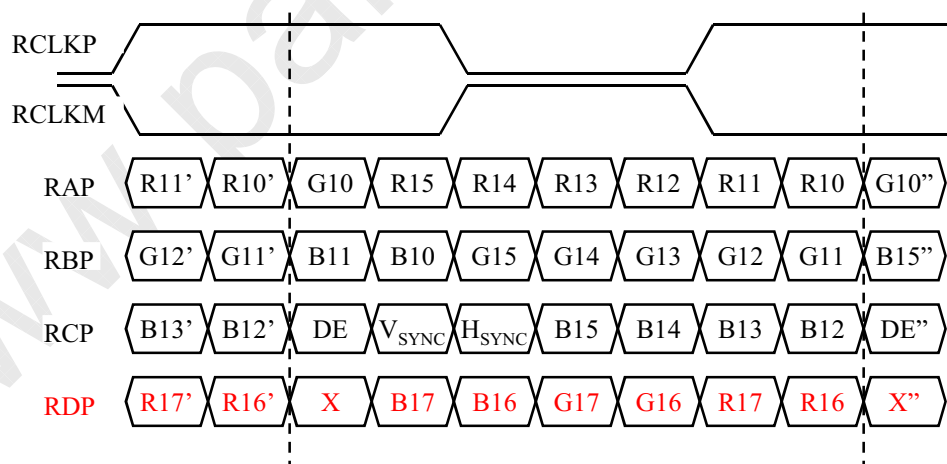

APPENDIX- V

■ Option Pin Circuit Block Diagram

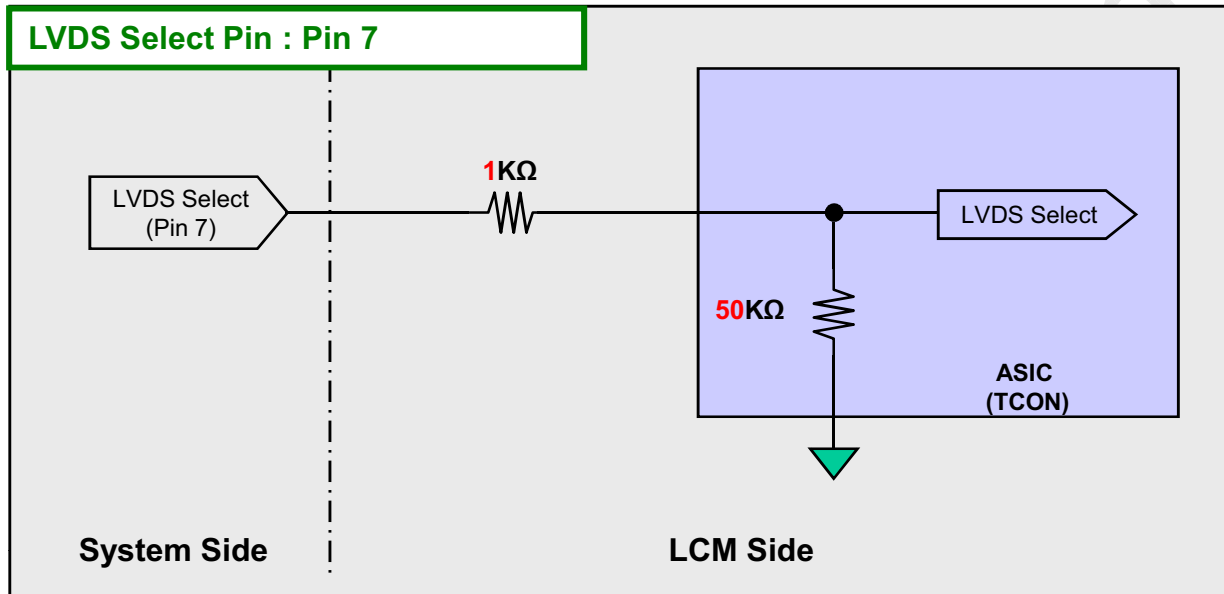
1) Circuit Block Diagram of **LVDS Format** Selection pin

LC420EUE

Product Specification

APPENDIX- VI

■ LED Array Electrical Spec

| Items | Symbol | Condition | Min | Typ | Max | Unit | |
|-------------------------|-----------------------|------------------------|-----------------------------|------|------|------|---|
| Array Operating Voltage | V_F | $T_a=0^\circ\text{C}$ | $I_{FM}=630\text{mA}^{*1)}$ | 61.2 | 66.8 | 71.8 | V |
| | | $T_a=25^\circ\text{C}$ | $I_{FM}=630\text{mA}^{*1)}$ | 59 | 64.4 | 69.2 | |
| | $\Delta V_{FM}^{*2)}$ | $I_{FM}=630\text{mA}$ | - | - | 1.7 | V | |

■ Forward Current vs. Forward Voltage

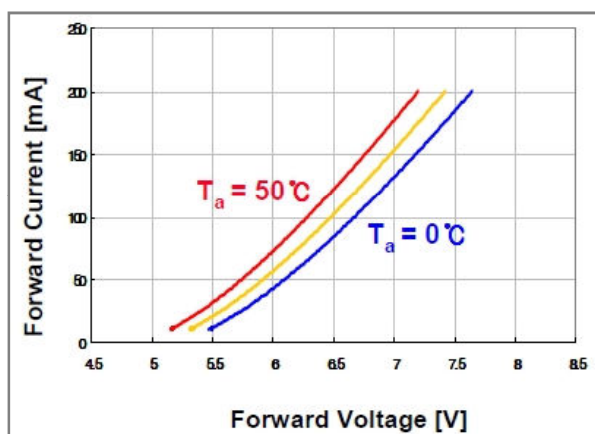

■ Ambient Temperature vs. Forward Voltage

