

Product Specification

SPECIFICATION

FOR

APPROVAL

- () Preliminary Specification
 (●) Final Specification

Title	42.0" WUXGA TFT LCD
--------------	----------------------------

BUYER	General
MODEL	BR42010D

SUPPLIER	LG.Display Co., Ltd.
BASE MODEL	LC420WUD
SUFFIX	SBM4 (High Luminance)

*When you obtain standard approval,
 please use the above model name without suffix

APPROVED BY	SIGNATURE DATE
/	_____
/	_____
/	_____

Please return 1 copy for your confirmation with
 your signature and comments.

APPROVED BY	SIGNATURE DATE
J. T KIM / Team Leader	_____
REVIEWED BY	
S. S Lee / Project Leader	_____
PREPARED BY	
D. K Yang / Engineer	_____

TV Products Development Dept.
LG. Display LCD Co., Ltd

Product Specification

CONTENTS

Number	Item	Page
	COVER	1
	CONTENTS	2
	RECORD OF REVISIONS	3
1	GENERAL DESCRIPTION	4
2	ABSOLUTE MAXIMUM RATINGS	5
3	ELECTRICAL SPECIFICATIONS	6
3-1	ELECTRICAL CHARACTERISTICS	6
3-2	INTERFACE CONNECTIONS	8
3-3	SIGNAL TIMING SPECIFICATIONS	10
3-4	SIGNAL TIMING WAVEFORMS	11
3-5	COLOR INPUT DATA REFERENCE	12
3-6	POWER SEQUENCE	13
4	OPTICAL SPECIFICATIONS	15
5	MECHANICAL CHARACTERISTICS	19
6	RELIABILITY	22
7	INTERNATIONAL STANDARDS	23
7-1	SAFETY	23
7-2	EMC	23
8	PACKING	24
8-1	DESIGNATION OF LOT MARK	24
8-2	PACKING FORM	24
9	PRECAUTIONS	25
9-1	MOUNTING PRECAUTIONS	25
9-2	OPERATING PRECAUTIONS	25
9-3	ELECTROSTATIC DISCHARGE CONTROL	26
9-4	PRECAUTIONS FOR STRONG LIGHT EXPOSURE	26
9-5	STORAGE	26
9-6	HANDLING PRECAUTIONS FOR PROTECTION FILM	26

Product Specification

1. General Description

LC420WUD is a Color Active Matrix Liquid Crystal Display

. The matrix employs a-Si Thin Film Transistor as the active element.

It is a transmissive type display operating in the normally black mode. It has a 42 inch diagonally measured active display area with WUXGA resolution (1080 vertical by 1920 horizontal pixel array) Each pixel is divided into Red, Green and Blue sub-pixels or dots which are arranged in vertical stripes. Gray scale or the luminance of the sub-pixel color is determined with a 10-bit gray scale signal for each dot, thus presenting a palette of more than 1.06Billion of colors.

It has been designed to apply the 10-bit 4 port LVDS interface.

It is intended to support LCD TV, PCTV where high brightness, super wide viewing angle, high color gamut, high color depth and fast moving picture response time are important.

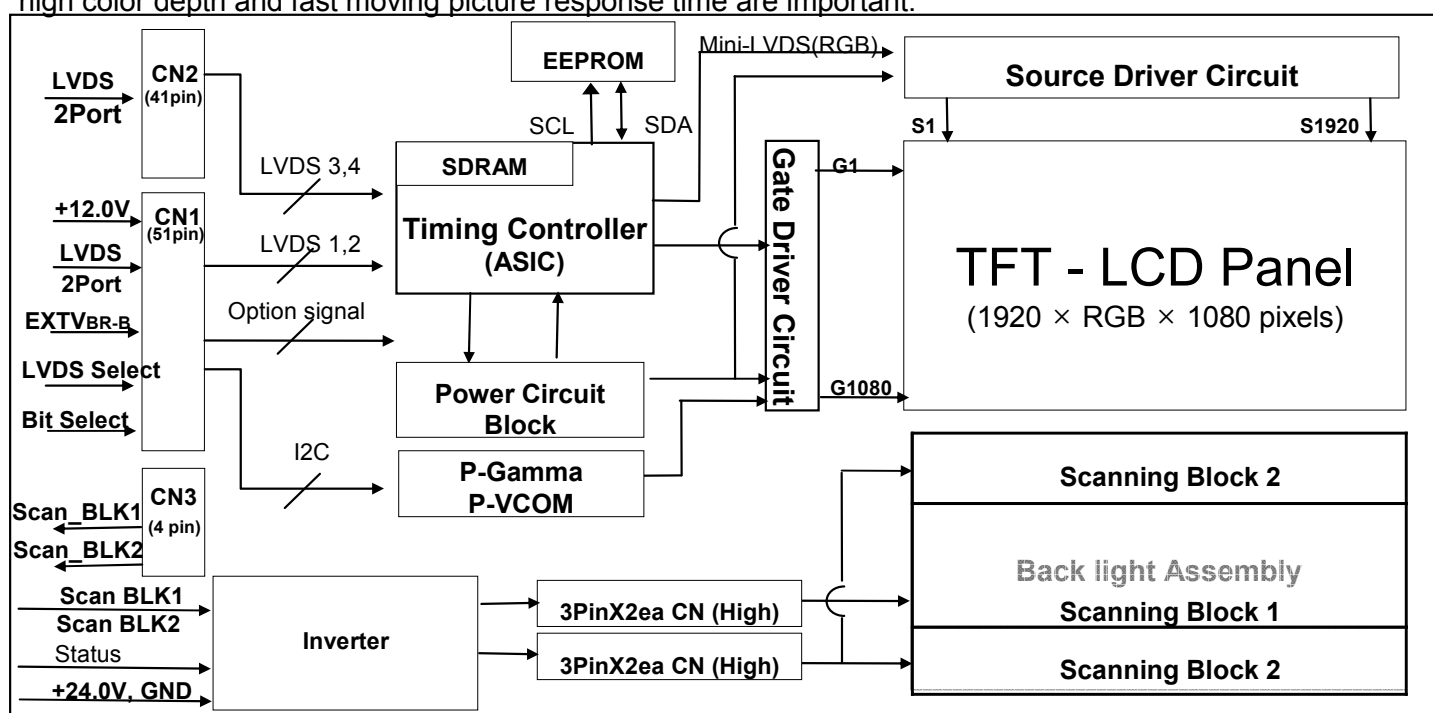

General Features

Active Screen Size	42.02 inches(1067.31mm) diagonal
Outline Dimension	965.2(H) x 558.2 (V) x 36.5 mm(D) (Typ.)
Pixel Pitch	0.4845 mm x 0.4845 mm
Pixel Format	1920 horiz. by 1080 vert. Pixels, RGB stripe arrangement
Color Depth	10bit(D) , 1.06Billion colors
Luminance, White	1000 cd/m ² (Center 1point ,Typ.)
Viewing Angle (CR>10)	Viewing angle free (R/L 178 (Typ.), U/D 178 (Typ.))
Power Consumption	Total 227.2 W (Typ.)(Logic = 7.2 W, Invertert=220 W @EXTVBR-B 85%)
Weight	10.7 Kg (Typ.)
Display Mode	Transmissive mode, Normally black
Surface Treatment	Hard coating(3H), Anti-glare treatment of the front polarizer (Haze 10%)

Product Specification

2. Absolute Maximum Ratings

The following items are maximum values which, if exceeded, may cause faulty operation or damage to the LCD module.

Table 1. ABSOLUTE MAXIMUM RATINGS

Parameter		Symbol	Value		Unit	Note
			Min	Max		
Power Input Voltage	LCD circuit	V _{LCD}	+8.0	+14.0	V _{DC}	at 25 ± 2 °C
	Inverter	V _{BL}	-0.3	27.0	V _{DC}	
Inverter Control Voltage	ON/OFF	V _{OFF} / V _{ON}	-0.3	+5.5	V _{DC}	
Brightness Control Voltage		EXTV _{BR-B}	-0.3	+4.0	V _{DC}	
Operating Temperature		T _{OP}	0	+50	°C	1,2
Storage Temperature		T _{ST}	-20	+60	°C	
Operating Ambient Humidity		H _{OP}	10	90	%RH	
Storage Humidity		H _{ST}	10	90	%RH	

Note 1. Temperature and relative humidity range are shown in the figure below.

Wet bulb temperature should be Max 39 °C, and no condensation of water.

2. Gravity mura can be guaranteed below 40 °C condition.

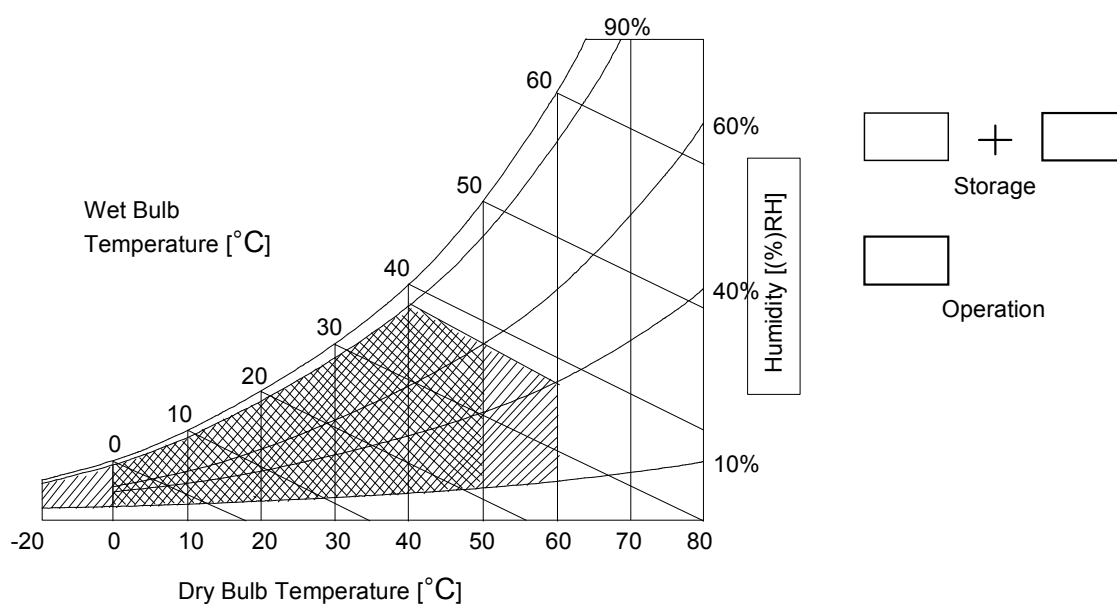

Product Specification

3. Electrical Specifications

3-1. Electrical Characteristics

It requires two power inputs. One is employed to power for the LCD circuit. The other is used for the LED backlight and inverter circuit.

Table 2. ELECTRICAL CHARACTERISTICS

Parameter	Symbol	Value			Unit	Note
		Min	Typ	Max		
Circuit :						
Power Input Voltage	V _{LCD}	10.8	12.0	13.2	V [DC]	
Power Input Current	I _{LCD}	-	600	780	mA	1
		-	840	1090	mA	2
Power Consumption	P _{LCD}		7.2	9.36	Watt	1
Rush current	I _{RUSH}	-	-	5	A	3

- Note :
1. The specified current and power consumption are under the $V_{LCD}=12.0V$, $25 \pm 2^{\circ}C$, $f_v=120Hz$ condition whereas mosaic pattern(8 x 6) is displayed and f_v is the frame frequency.
 2. The current is specified at the maximum current pattern.
 3. The duration of rush current is about 2ms and rising time of power input is 0.5ms (min.).

White : 1023Gray
Black : 0Gray

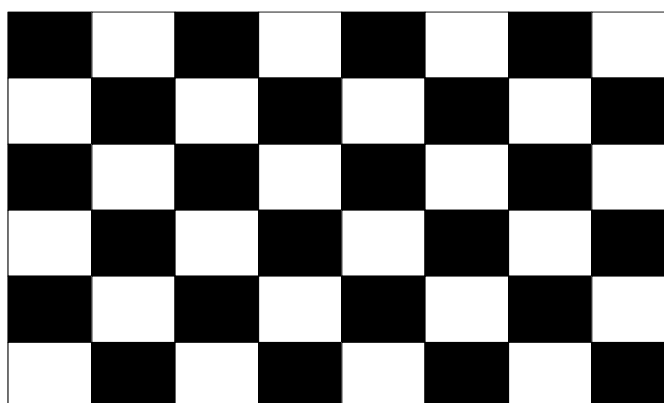

Mosaic Pattern(8 x 6)

Product Specification

Table 3. ELECTRICAL CHARACTERISTICS (Continue)

Parameter		Symbol	Values			Unit	Notes	
			Min	Typ	Max			
Inverter :								
Power Supply Input Voltage		V _{BL}	22.8	24.0	25.2	V _{DC}	1	
Power Supply Input Current	After Aging	I _{BL_A}	-			A	V _{BR-A} = 1.65V ... 1	
			-	9.0	9.2	A	V _{BR-A} = 3.3V ... 1	
	Before Aging	I _{BL_B}	-			A	V _{BR-A} = 1.65V ... 2	
			-			A	V _{BR-A} = 3.3V ... 2	
Power Supply Input Current (In-Rush)		I _{RUSH}	-	-	12	A	V _{BL} = 22.8V EXTV_{BR-B} = 100% V _{BR-A} = 1.65V	
Power Consumption		P _{BL}	-	216	220	W	V _{BR-A} = 3.3 V ... 1	
Input Voltage for Control System Signals	Brightness Adjust		V _{BR-A}	0.0	1.65	3.3	V _{DC}	
	On/Off	On	V _{ON}	2.5	-	5.0	V _{DC}	
		Off	V _{OFF}	-0.3	0.0	0.8	V _{DC}	
	Brightness Adjust		EXTV_{BR-B}	20	-	85	%	On Duty
	Pulse Duty Level (EXTV_{BR-B})	High Level		2.5	-	5.0	V _{DC}	HIGH: Lamp on LOW : Lamp off
		Low Level		-0.3	0.0	0.8	V _{DC}	
Lamp:								
Discharge Stabilization Time		T _s			0	min	3	
Life Time			50,000			Hrs	4	

Notes :

- Electrical characteristics are determined after the unit has been 'ON' and stable for approximately 120 minutes at 25±2°C. The specified current and power consumption are under the typical supply Input voltage 24V and V_{BR} (V_{BR-A} : 3.3V & **EXTV_{BR-B}** : 85%), it is total power consumption.
- Electrical characteristics are determined within 30 minutes at 25±2°C.
The specified currents are under the typical supply Input voltage 24V.
- The brightness of the lamp after lighted for 5minutes is defined as 100%.
T_S is the time required for the brightness of the center of the lamp to be not less than 95% at typical current.
The screen of LCD module may be partially dark by the time the brightness of lamp is stable after turn on.
- Specified Values are for a single lamp which is aligned horizontally.
The life time is determined as the time which luminance of the lamp is 50% compared to that of initial value at the typical lamp current (V_{BR-A} : 1.65V & **EXTV_{BR-B}** : 85%), on condition of continuous operating at 25± 2°C
- The duration of rush current is about 10ms.
- PWM_TIN is based on input PWM duty of the Timing controller.

Product Specification

3-2. Interface Connections

This LCD module employs two kinds of interface connection, 51-pin and 41-pin connector is used for the module electronics and Master 14-pin and Slave 12-pin connectors are used for the integral backlight system.

3-2-1. LCD Module

- LCD Connector(CN1): FI-R51S-HF(manufactured by JAE) or KN25-51P-0.5SH(manufactured by Hirose) (CN1) Refer to below and next Page table
- Mating Connector : FI-R51HL(JAE) or compatible

Table 4-1. MODULE CONNECTOR(CN1) PIN CONFIGURATION

No	Symbol	Description	No	Symbol	Description
1	GND	Ground	27	Bit Select	'H' or NC= 10bit(D) , 'L' = 8bit
2	NC	No Connection	28	R2AN	SECOND LVDS Receiver Signal (A-)
3	NC	No Connection	29	R2AP	SECOND LVDS Receiver Signal (A+)
4	NC	No Connection	30	R2BN	SECOND LVDS Receiver Signal (B-)
5	NC	No Connection	31	R2BP	SECOND LVDS Receiver Signal (B+)
6	NC	No Connection	32	R2CN	SECOND LVDS Receiver Signal (C-)
7	LVDS Select	'H' =JEIDA , 'L' or NC = VESA	33	R2CP	SECOND LVDS Receiver Signal (C+)
8	EXTVBR-B	External VBR (From System)	34	GND	Ground
9	NC	No Connection	35	R2CLKN	SECOND LVDS Receiver Clock Signal(-)
10	OPC Enable	'H' = Enable , 'L' or NC = Disable	36	R2CLKP	SECOND LVDS Receiver Clock Signal(+)
11	NC	No Connection	37	GND	Ground
12	R1AN	FIRST LVDS Receiver Signal (A-)	38	R2DN	SECOND LVDS Receiver Signal (D-)
13	R1AP	FIRST LVDS Receiver Signal (A+)	39	R2DP	SECOND LVDS Receiver Signal (D+)
14	R1BN	FIRST LVDS Receiver Signal (B-)	40	R2EN	SECOND LVDS Receiver Signal (E-)
15	R1BP	FIRST LVDS Receiver Signal (B+)	41	R2EP	SECOND LVDS Receiver Signal (E+)
16	R1CN	FIRST LVDS Receiver Signal (C-)	42	Reserved	No connection or GND
17	R1CP	FIRST LVDS Receiver Signal (C+)	43	Reserved	No connection or GND
18	GND	Ground	44	GND	Ground
19	R1CLKN	FIRST LVDS Receiver Clock Signal(-)	45	GND	Ground
20	R1CLKP	FIRST LVDS Receiver Clock Signal(+)	46	GND	Ground
21	GND	Ground	47	NC	No connection
22	R1DN	FIRST LVDS Receiver Signal (D-)	48	VLCD	Power Supply +12.0V
23	R1DP	FIRST LVDS Receiver Signal (D+)	49	VLCD	Power Supply +12.0V
24	R1EN	FIRST LVDS Receiver Signal (E-)	50	VLCD	Power Supply +12.0V
25	R1EP	FIRST LVDS Receiver Signal (E+)	51	VLCD	Power Supply +12.0V
26	Reserved	No connection or GND	-	-	-

- Notes :
1. All GND(ground) pins should be connected together to the LCD module's metal frame.
 2. All V_{LCD} (power input) pins should be connected together.
 3. All Input levels of LVDS signals are based on the **EIA 644** Standard.
 4. Specific pins(**pin No. #2~#6**) are used for internal data process of the LCD module.
If not used, these pins are no connection.
 5. Specific pins(**pin No. #8**) is used for **OPC function** of the LCD module.
If not used, these pins are no connection. (Please see the **Appendix V** for more information.)
 6. LVDS pin (**pin No. #24,25,40,41**) are used for 10Bit(D) of the LCD module.
If used for 8Bit(R), these pins are no connection.
 7. Specific **pin No. #44** is used for "No signal detection" of system signal interface.
It should be GND for **NSB(No Signal Black)** during the system interface signal is not.
If this pin is "H", LCD Module displays **AGP(Auto Generation Pattern)**.

Product Specification

- LCD Connector(CN2): FI-RE41S-HF (manufactured by JAE) or KN25-41P-0.5SH (manufactured by Hirose)
- Mating Connector : FI-RE41HL

Table 4-2. MODULE CONNECTOR(CN2) PIN CONFIGURATION

No	Symbol	Description	No	Symbol	Description
1	NC	No connection(Reserved)	22	RE3N	Third CHANNEL E-
2	NC	No connection	23	RE3P	Third CHANNEL E+
3	NC	No connection	24	GND	Ground
4	NC	No connection	25	GND	Ground
5	NC	No connection	26	RA4N	Fourth CHANNEL A-
6	NC	No connection	27	RA4P	Fourth CHANNEL A+
7	NC	No connection	28	RB4N	Fourth CHANNEL B-
8	NC	No connection	29	RB4P	Fourth CHANNEL B+
9	GND	Ground	30	RC4N	Fourth CHANNEL C-
10	RA3N	Third CHANNEL A-	31	RC4P	Fourth CHANNEL C+
11	RA3P	Third CHANNEL A+	32	GND	Ground
12	RB3N	Third CHANNEL B-	33	RCLK4N	Fourth CLOCK CHANNEL Clk-
13	RB3P	Third CHANNEL B+	34	RCLK4P	Fourth CLOCK CHANNEL Clk+
14	RC3N	Third CHANNEL C-	35	GND	Ground
15	RC3P	Third CHANNEL C+	36	RD4N	Fourth CHANNEL D-
16	GND	Ground	37	RD4P	Fourth CHANNEL D+
17	RCLK3N	Third CLOCK CHANNEL Clk-	38	RE4N	Fourth CHANNEL E-
18	RCLK3P	Third CLOCK CHANNEL Clk+	39	RE4P	Fourth CHANNEL E+
19	GND	Ground	40	GND	Ground
20	RD3N	Third CHANNEL D-	41	GND	Ground
21	RD3P	Third CHANNEL D+	-		

- Notes : 1. All GND(ground) pins should be connected together to the LCD module's metal frame.
 2. LVDS pin (**pin No. #22,23,38,39**) are used for 10Bit(D) of the LCD module.
 If used for 8Bit(R), these pins are no connection.

Table 4-3. MODULE CONNECTOR(CN3) PIN CONFIGURATION

No	Symbol	Description
1	REF MODE	Reference Mode Signal
2	SCAN_BLK1	Scanning_BLK1 Signal (Output)
3	SCAN_BLK2	Scanning_BLK2 Signal (Output)
4	GND	Ground

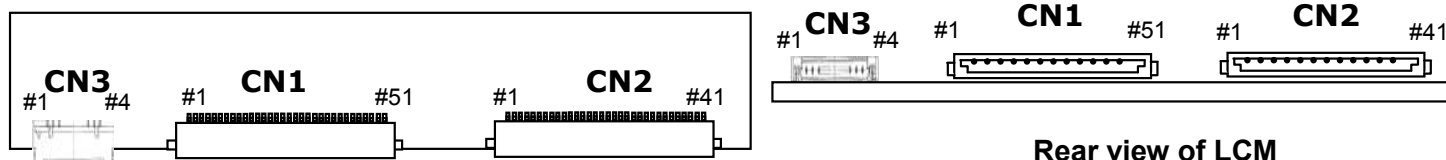

Product Specification

3-2-2. Backlight Module

Master

- Inverter Connector : 20022WR-14B1 (manufactured by Yeonho) or Equivalent
- Mating Connector : 20022HS-14 or Equivalent

Slave

- Inverter Connector : 20022WR-14B1 (manufactured by Yeonho) or Equivalent
- Mating Connector : 20022HS-14 or Equivalent

Pin No	Symbol	Description	Master	Slave	Note
1	VBL	Power Supply +24.0V	VBL	VBL	
2	VBL	Power Supply +24.0V	VBL	VBL	
3	VBL	Power Supply +24.0V	VBL	VBL	
4	VBL	Power Supply +24.0V	VBL	VBL	
5	VBL	Power Supply +24.0V	VBL	VBL	
6	GND	Backlight Ground	GND	GND	
7	GND	Backlight Ground	GND	GND	
8	GND	Backlight Ground	GND	GND	
9	GND	Backlight Ground	GND	GND	
10	GND	Backlight Ground	GND	GND	
11	NC	NC	-	Don't care	
12	VON/OFF	Backlight ON/OFF control	VON/OFF		
13	VBR	PWM/Analog Dimming	VBR-A		
14	Status	Lamp Status	Status	-	

Notes : 1. GND should be connected to the LCD module's metal frame.

2. Minimum Brightness : 0.0V / Maximum Brightness : 3.3V / "OPEN" : 1.65V

3. ON : 2.5 ~ 5.0V / OFF : 0.0 ~ 0.8V . Open or 'H' for B/L On is default status.

4. Normal : Low (under 0.7V) / Abnormal : High (upper 3.0V)

Please see **Appendix VI** for more information.

5. Each impedance of pin #13, 12 is **143 [KΩ]** , **40 [KΩ]**

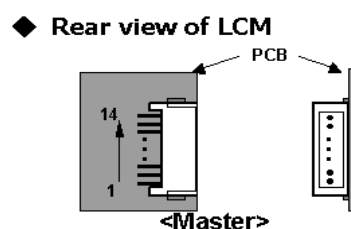
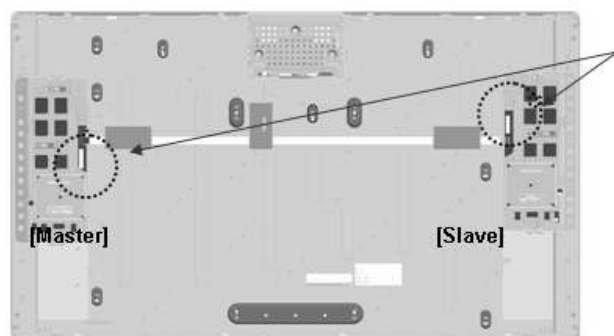

Product Specification

3-3. Signal Timing Specifications

Table 6 shows the signal timing required at the input of the LVDS transmitter. All of the interface signal timing should be satisfied with the following specification for normal operation.

Table 6-1. TIMING TABLE for NTSC/PAL (DE Only Mode)

ITEM		Symbol	Min	Typ	Max	Unit	Note
Horizontal	Display Period	tHV	480	480	480	tCLK	1920/4
	Blank	tHB	40	70	200	tCLK	1
	Total	tHP	520	550	680	tCLK	
Vertical	Display Period	tVV	1080	1080	1080	Lines	
	Blank	tVB	10	45	86	Lines	1
	Total	tVP	1090	1125	1166	Lines	
Frequency	DCLK	fCLK	66.97	74.25	78.00	MHz	
	Horizontal	fH	121.8	135	136.4	KHz	2
	Vertical	fV	108.2	120	121.2	Hz	2

Table 6-2 TIMING TABLE for DVB/PAL (DE Only Mode)

ITEM		Symbol	Min	Typ	Max	Unit	Note
Horizontal	Display Period	tHV	480	480	480	tCLK	1920/4
	Blank	tHB	40	70	200	tCLK	1
	Total	tHP	520	550	680	tCLK	
Vertical	Display Period	tVV	1080	1080	1080	Lines	
	Blank	tVB	228	270	300	Lines	1
	Total	tVP	1308	1350	1380	Lines	
Frequency	DCLK	fCLK	66.97	74.25	78.00	MHz	
	Horizontal	fH	121.8	135	140	KHz	2
	Vertical	fV	95	100	103.7	Hz	2

- Notes : 1. The Input of HSYNC & VSYNC signal does not have an effect on normal operation(DE Only Mode). If you use spread spectrum for EMI, add some additional clock to minimum value for clock margin.
2. The performance of the electro-optical characteristics may be influenced by variance of the vertical refresh rate and the horizontal frequency.

Product Specification

3-4. Signal Timing Waveforms

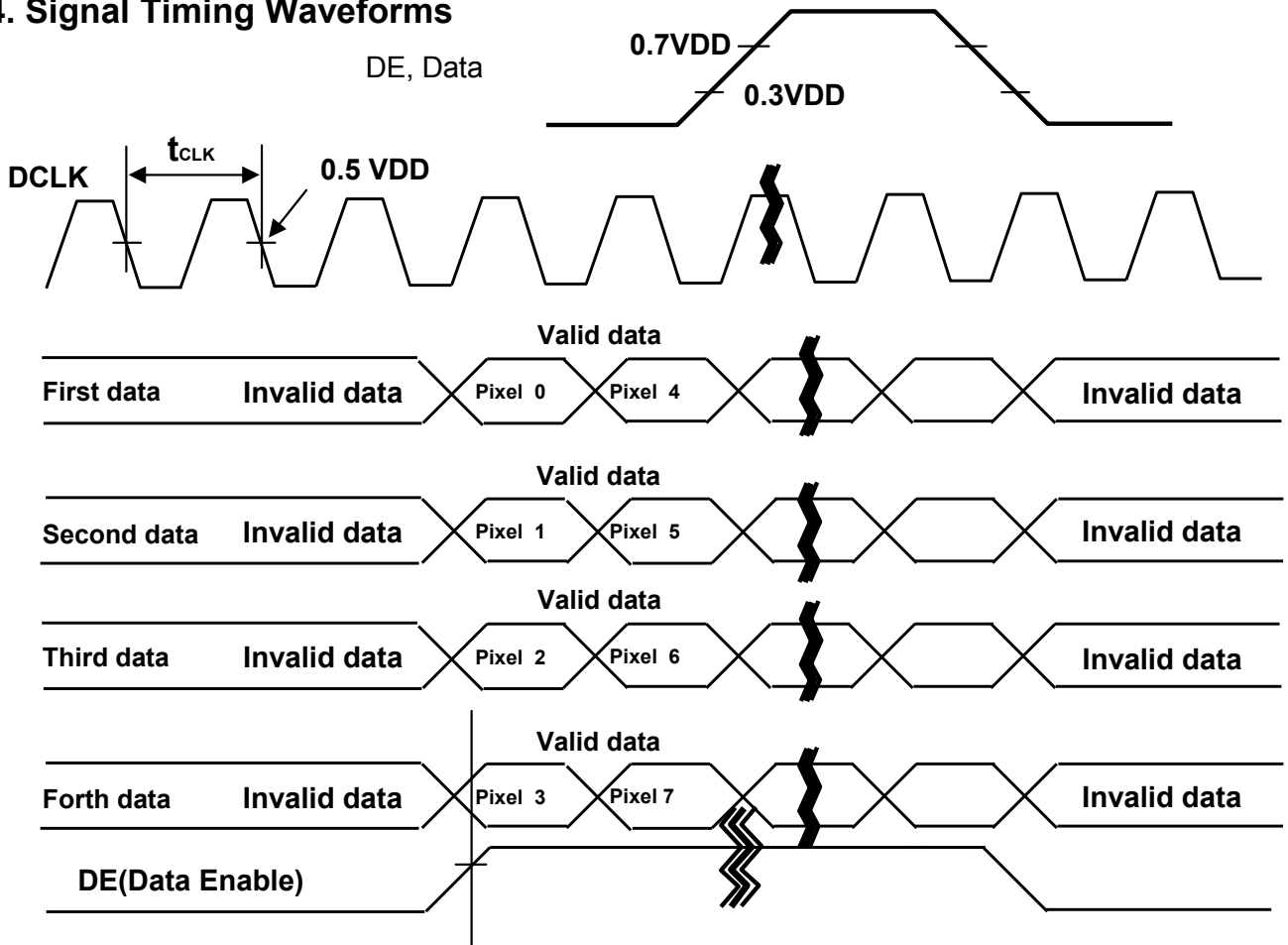

* $t_{HB} = t_{HFP} + t_{WH} + t_{HBP}$

* $t_{VB} = t_{VFP} + t_{VW} + t_{VBP}$

* Reference : Sync. Relation

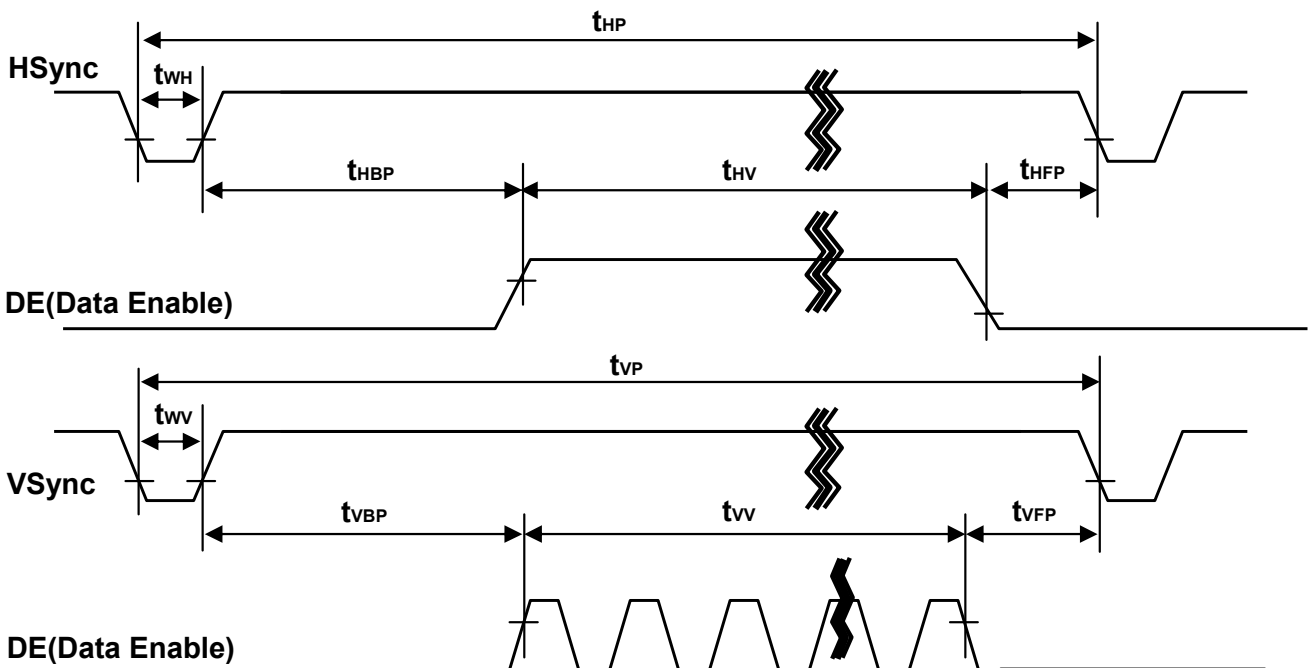

Product Specification

3-5. Color Data Reference

The brightness of each primary color(red,green,blue) is based on the 10bit gray scale data input for the color. The higher binary input, the brighter the color. Table 7 provides a reference for color versus data input.

Table 7. COLOR DATA REFERENCE

Color		Input Color Data																													
		RED										GREEN					BLUE														
		MSB	LSB								MSB	LSB				MSB	LSB														
		R9	R8	R7	R6	R5	R4	R3	R2	R1	R0	G9	G8	G7	G6	G5	G4	G3	G2	G1	G0	B9	B8	B7	B6	B5	B4	B3	B2	B1	B0
Basic Color	Black	0	0	0	0	0	0	0	0	0	0	0	0	0	0	0	0	0	0	0	0	0	0	0	0	0	0	0	0	0	0
	Red (1023)	1	1	1	1	1	1	1	1	1	1	0	0	0	0	0	0	0	0	0	0	0	0	0	0	0	0	0	0	0	0
	Green (1023)	0	0	0	0	0	0	0	0	0	0	1	1	1	1	1	1	1	1	1	1	0	0	0	0	0	0	0	0	0	0
	Blue (1023)	0	0	0	0	0	0	0	0	0	0	0	0	0	0	0	0	0	0	0	0	1	1	1	1	1	1	1	1	1	1
	Cyan	0	0	0	0	0	0	0	0	0	0	1	1	1	1	1	1	1	1	1	1	1	1	1	1	1	1	1	1	1	1
	Magenta	1	1	1	1	1	1	1	1	1	1	0	0	0	0	0	0	0	0	0	0	1	1	1	1	1	1	1	1	1	1
	Yellow	1	1	1	1	1	1	1	1	1	1	1	1	1	1	1	1	1	1	1	1	0	0	0	0	0	0	0	0	0	0
	White	1	1	1	1	1	1	1	1	1	1	1	1	1	1	1	1	1	1	1	1	1	1	1	1	1	1	1	1	1	1
RED	RED (0000)	0	0	0	0	0	0	0	0	0	0	0	0	0	0	0	0	0	0	0	0	0	0	0	0	0	0	0	0	0	
	RED (0001)	0	0	0	0	0	0	0	0	0	1	0	0	0	0	0	0	0	0	0	0	0	0	0	0	0	0	0	0	0	0
														
	RED (1022)	1	1	1	1	1	1	1	1	1	0	0	0	0	0	0	0	0	0	0	0	0	0	0	0	0	0	0	0	0	0
	RED (1023)	1	1	1	1	1	1	1	1	1	1	0	0	0	0	0	0	0	0	0	0	0	0	0	0	0	0	0	0	0	0
GREEN	GREEN (0000)	0	0	0	0	0	0	0	0	0	0	0	0	0	0	0	0	0	0	0	0	0	0	0	0	0	0	0	0	0	
	GREEN (0001)	0	0	0	0	0	0	0	0	0	0	0	0	0	0	0	0	0	0	1	0	0	0	0	0	0	0	0	0	0	
														
	GREEN (1022)	0	0	0	0	0	0	0	0	0	0	1	1	1	1	1	1	1	1	1	0	0	0	0	0	0	0	0	0	0	0
	GREEN (1023)	0	0	0	0	0	0	0	0	0	0	1	1	1	1	1	1	1	1	1	1	0	0	0	0	0	0	0	0	0	0
BLUE	BLUE (0000)	0	0	0	0	0	0	0	0	0	0	0	0	0	0	0	0	0	0	0	0	0	0	0	0	0	0	0	0	0	
	BLUE (0001)	0	0	0	0	0	0	0	0	0	0	0	0	0	0	0	0	0	0	0	0	0	0	0	0	0	0	0	1	0	
														
	BLUE (1022)	0	0	0	0	0	0	0	0	0	0	0	0	0	0	0	0	0	0	0	0	1	1	1	1	1	1	1	1	1	0
	BLUE (1023)	0	0	0	0	0	0	0	0	0	0	0	0	0	0	0	0	0	0	0	0	1	1	1	1	1	1	1	1	1	1

Product Specification

3-6. Power Sequence

3-6-1. LCD Driving circuit

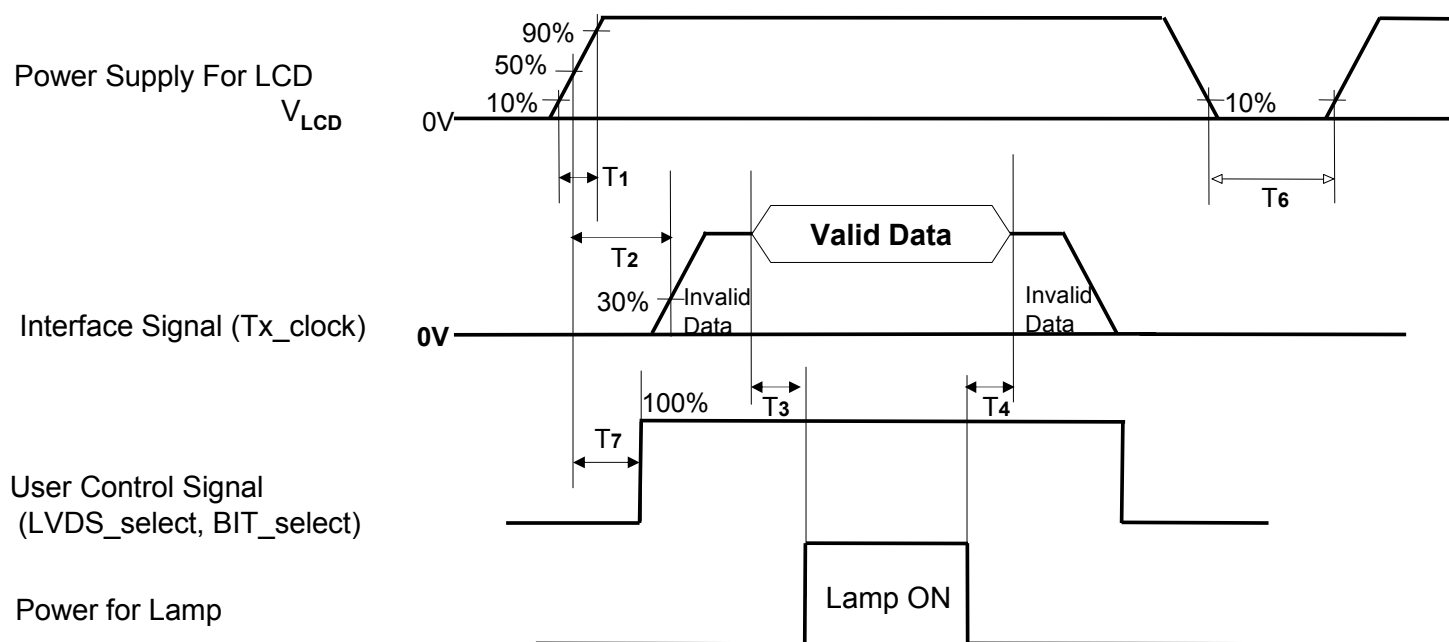

Table 8. POWER SEQUENCE

Parameter	Value			Unit	Note
	Min	Typ	Max		
T1	0.5	-	20	ms	
T2	0	-	-	ms	4
T3	200	-	-	ms	3
T4	200	-	-	ms	3
T6	1.0	-	-	s	5
T7	0	-	T2	ms	4

Note :1. Please avoid floating state of interface signal at invalid period.

2. When the power supply for LCD (V_{LCD}) is off, be sure to pull down the valid and invalid data to 0V.

3. The T3/T4 is recommended value, the case when failed to meet a minimum specification, abnormal display would be shown. There is no reliability problem.

4. If the on time of signals (Interface signal and user control signals) precedes the on time of Power (V_{LCD}), it will be happened abnormal display. When T7 is NC status, T7 doesn't need to be measured.

5. T6 should be measured after the Module has been fully discharged between power off and on period.

Product Specification

3-6-2. Sequence for Inverter

Power Supply For Inverter

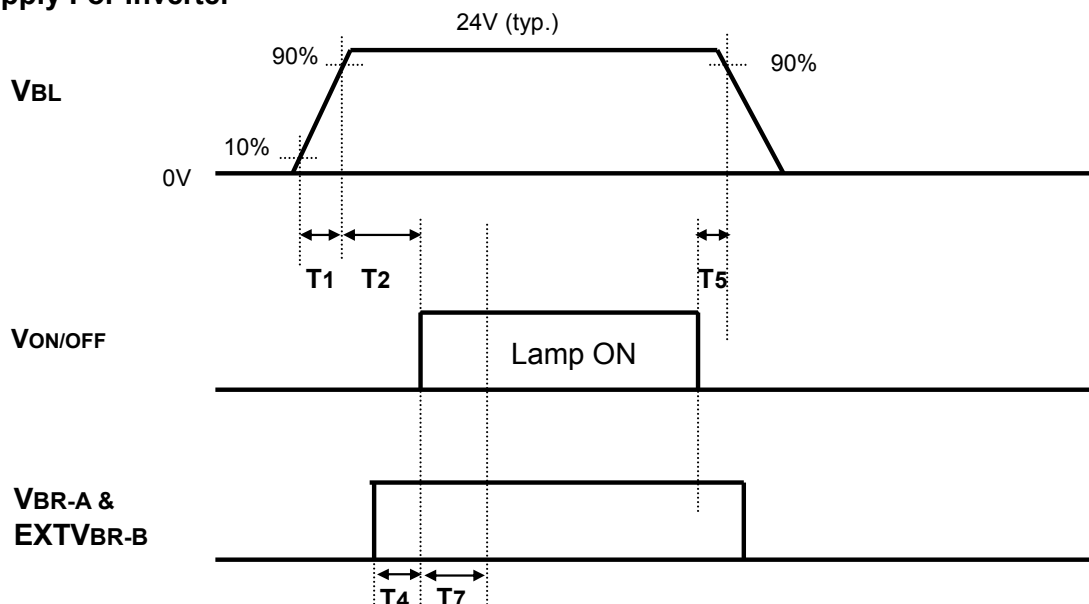

3-6-3. Deep condition for Inverter

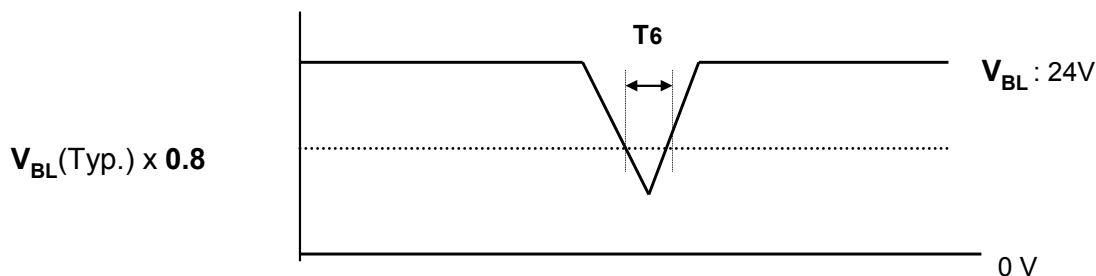

Table 9. POWER SEQUENCE

Parameter	Values			Units	Remarks
	Min	Typ	Max		
T1	20	-	-	ms	1
T2	500	-	-	ms	
T4	0		-	ms	2
T5	10	-	-	ms	
T6	-	-	10	ms	$V_{BL}(\text{Typ.}) \times 0.80$
T7	1000	-	-	ms	2

- T1 describes rising time of 0V to 24V and this parameter does not applied at restarting time. Even though T1 is over the specified value, there is no problem if i^2t spec of fuse is satisfied.
- In T4 section, EXT VBR-B is not recommend 100%, but in T7 section, EXT VBR-B is certainly recommend 100%, (up to 60% when varied by OPC function.)

Product Specification

4. Optical Specification

Optical characteristics are determined after the unit has been 'ON' and stable in a dark environment at $25\pm 2^{\circ}\text{C}$. The values are specified at an approximate distance 50cm from the LCD surface at a viewing angle of Φ and θ equal to 0° .

It is presented additional information concerning the measurement equipment and method in FIG. 1.

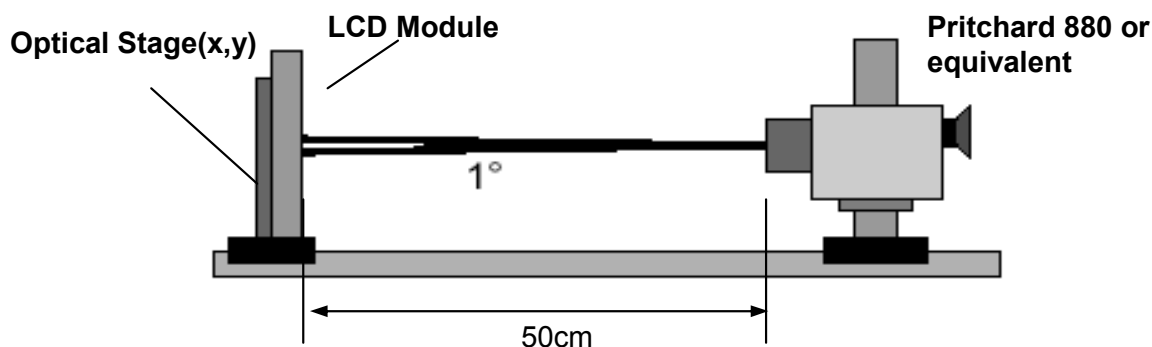

FIG. 1 Optical Characteristic Measurement Equipment and Method

Table 9. OPTICAL CHARACTERISTICS

$T_a = 25\pm 2^{\circ}\text{C}$, $V_{\text{LCD}} = 12.0\text{V}$, $f_v = 120\text{Hz}$, $D_{\text{clk}} = 74.25\text{MHz}$,
 $V_{\text{BR-A}} = 1.65\text{V}$, $\text{EXTV}_{\text{BR-B}} = 85\%$

Parameter	Symbol	Value			Unit	Note	
		Min	Typ	Max			
Contrast Ratio	CR	1000	1200	-		1	
Surface Luminance, white	L_{WH}	950	1000	-	cd/m ²	2	
Luminance Variation	δ_{WHITE} 5P	-	-	1.3		3	
Response Time	MPRT	MPRT	-	6	10	ms	4
	Uniformity	δ_{MPRT}	-	-	1		
Color Coordinates [CIE1931]	RED	Rx	Typ -0.03	0.638	Typ +0.03		
		Ry		0.334			
	GREEN	Gx		0.290			
		Gy		0.606			
	BLUE	Bx		0.144			
		By		0.064			
	WHITE	Wx		0.279			
Wy	0.292						
Viewing Angle (CR>10)							
	x axis, right($\phi=0^{\circ}$)	θ_r	89	-	-	degree	5
	x axis, left ($\phi=180^{\circ}$)	θ_l	89	-	-		
	y axis, up ($\phi=90^{\circ}$)	θ_u	89	-	-		
	y axis, down ($\phi=270^{\circ}$)	θ_d	89	-	-		
Gray Scale			-	-	-		6

Product Specification

Note : 1. Contrast Ratio(CR) is defined mathematically as :

$$\text{Contrast Ratio} = \frac{\text{Surface Luminance with all white pixels}}{\text{Surface Luminance with all black pixels}}$$

It is measured at center 1-point.

2. Surface luminance are determined after the unit has been 'ON' and 1 Hour after lighting the backlight in a dark environment at $25 \pm 2^\circ\text{C}$. Surface luminance is the luminance value at center 1-point across the LCD surface 50cm from the surface with all pixels displaying white. For more information see the FIG. 2.
3. The variation in surface luminance, δ WHITE is defined as :

$$\delta \text{ WHITE}(5P) = \text{Maximum}(L_{\text{on}1}, L_{\text{on}2}, L_{\text{on}3}, L_{\text{on}4}, L_{\text{on}5}) / \text{Minimum}(L_{\text{on}1}, L_{\text{on}2}, L_{\text{on}3}, L_{\text{on}4}, L_{\text{on}5})$$
 Where $L_{\text{on}1}$ to $L_{\text{on}5}$ are the luminance with all pixels displaying white at 5 locations . For more information, see the FIG. 2.
4. MPRT is defined as the 10% to 90% blur-edge width B_{ij} (pixels) and scroll speed U (pixels/frame)at the moving picture. For more information, see FIG 4
5. Viewing angle is the angle at which the contrast ratio is greater than 10. The angles are determined for the horizontal or x axis and the vertical or y axis with respect to the z axis which is normal to the LCD module surface. For more information, see the FIG. 4.
6. Gray scale specification
Gamma Value is approximately 2.2. For more information, see the Table 11.

Table 11. GRAY SCALE SPECIFICATION

Gray Level	Luminance [%] (Typ.)
L0	0.08
L63	0.27
L127	1.04
L191	2.49
L255	4.68
L319	7.66
L383	11.5
L447	16.1
L511	21.6
L575	28.1
L639	35.4
L703	43.7
L767	53.0
L831	63.2
L895	74.5
L959	86.7
L1023	100

Product Specification

Measuring point for surface luminance & measuring point for luminance variation.

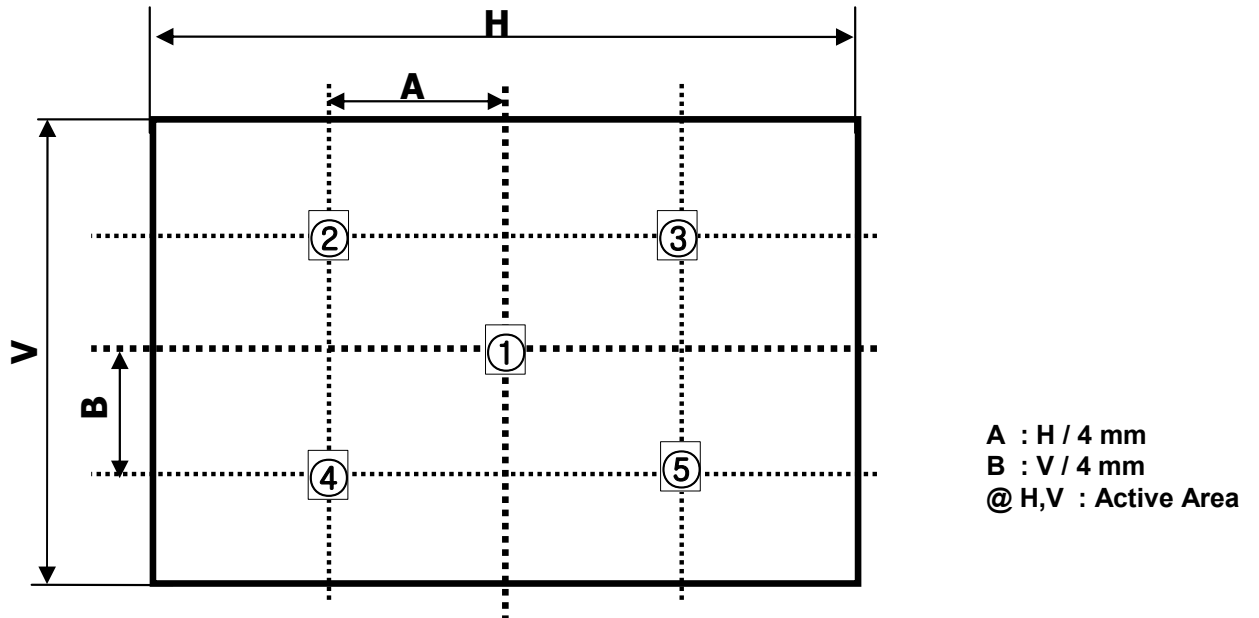
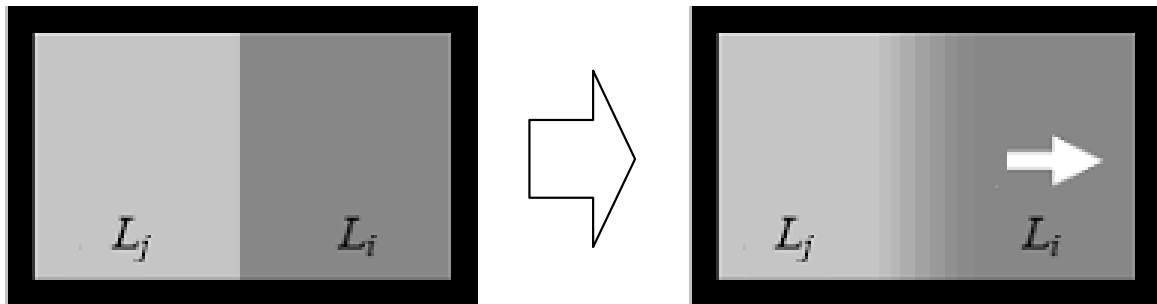

FIG. 2 5 Points for Luminance Measure

MPRT is defined as the 10% to 90% blur-edge with B_{ij} (pixels) and scroll speed U (pixels/frame)at the moving picture.



$$M = \frac{1}{U} B_{ij} \quad (i \neq j)$$

Example) $B_{ij} = 12$ pixels, $U = 10$ pixels / 120Hz

$$\begin{aligned} M &= 12\text{pixels} / (10\text{pixels} / 120\text{Hz}) \\ &= 12\text{pixels} / \{10\text{pixels} / (1/120)\text{s}\} \\ &= 12 / 1,200 \text{ s} \\ &= 10 \text{ ms} \end{aligned}$$

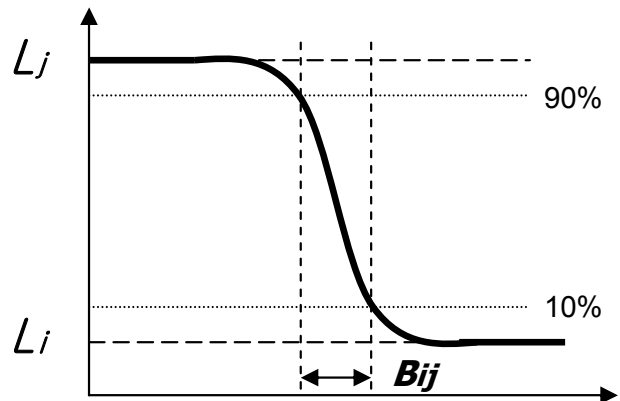

FIG. 4 MPRT

Product Specification

Dimension of viewing angle range

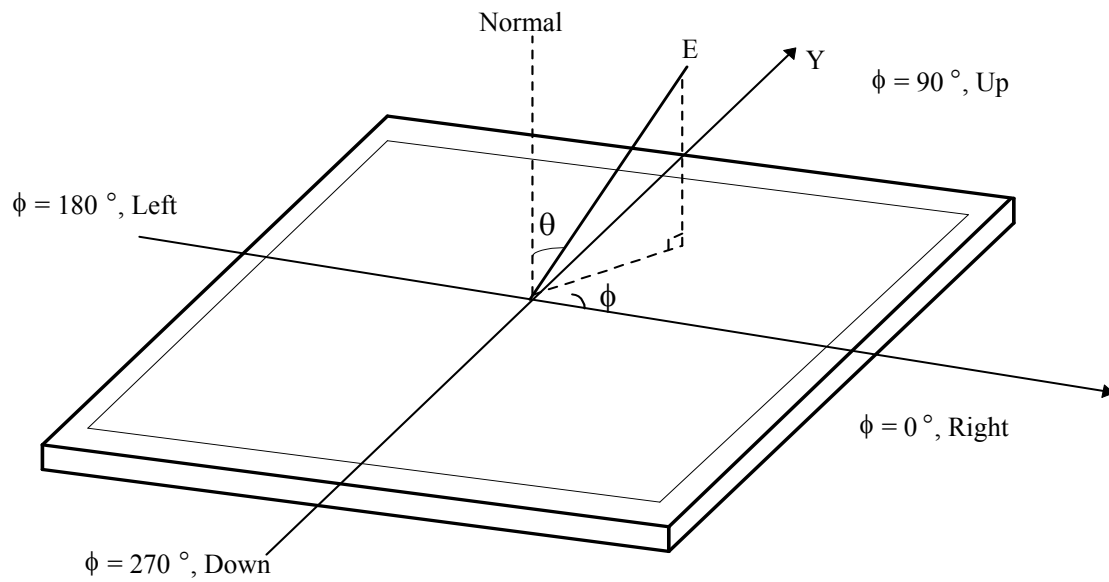

FIG. 5 Viewing Angle

Product Specification

5. Mechanical Characteristics

Table 11 provides general mechanical characteristics.

Table 11. MECHANICAL CHARACTERISTICS

Item	Value	
Outline Dimension	Horizontal	965.2 mm
	Vertical	558.2 mm
	Depth	36.5 mm
Bezel Area	Horizontal	938.2 mm
	Vertical	531.0 mm
Active Display Area	Horizontal	930.24 mm
	Vertical	523.26 mm
Weight	10.7 Kg (Typ.) , 12.0 Kg (Max.)	

Note : Please refer to a mechanical drawing in terms of tolerance at the next page.

Product Specification

<FRONT VIEW>

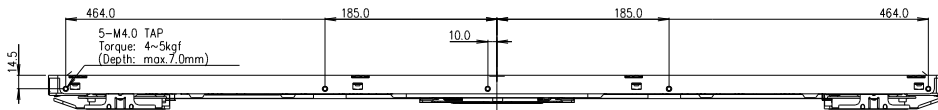
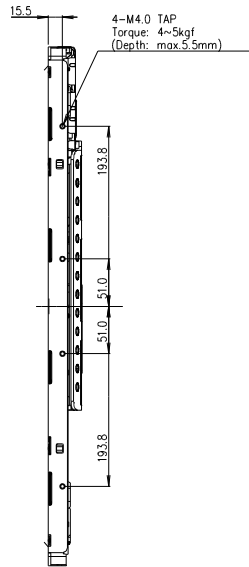
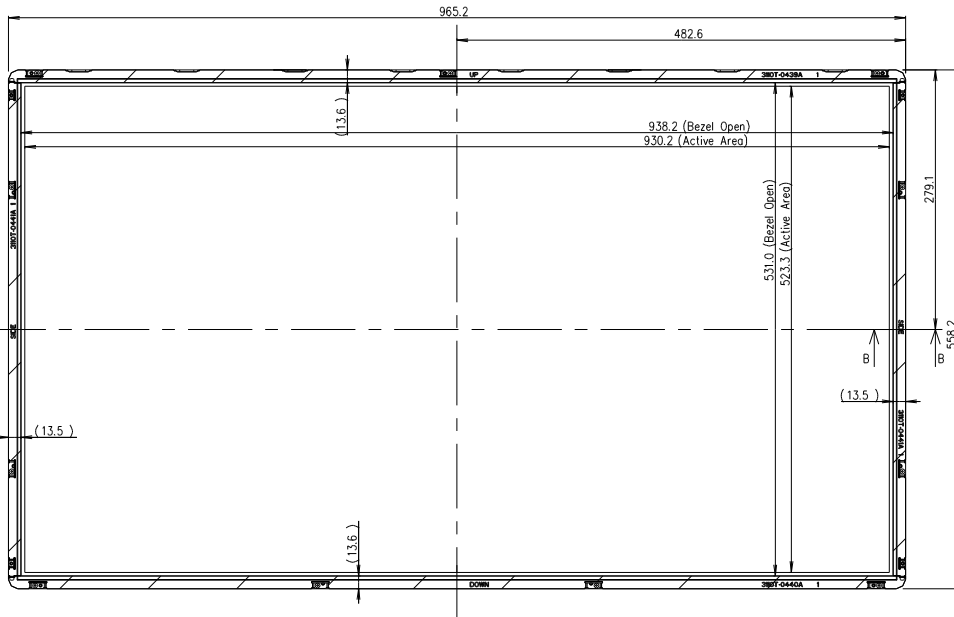
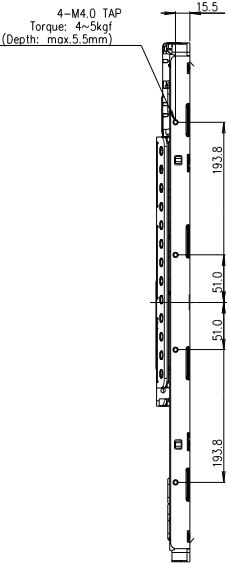
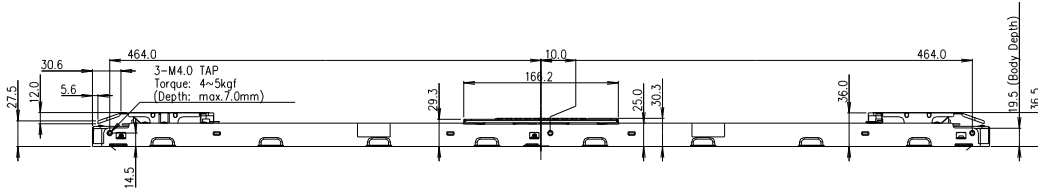

NOTES

1. Unspecified tolerances are to be $\pm 1.0\text{mm}$.
2. Tilt and partial disposition tolerance of display area are as following.
 - (1) X-Direction : $IA-BI \leq 1.5\text{mm}$
 - (2) Y-Direction : $IC-DI \leq 1.5\text{mm}$

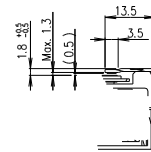
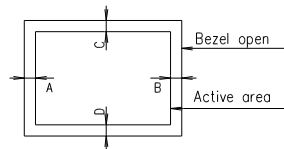

SECTION B-B
SCALE 1/1

Product Specification

<REAR VIEW>

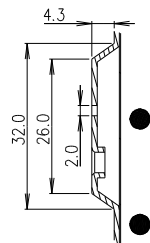
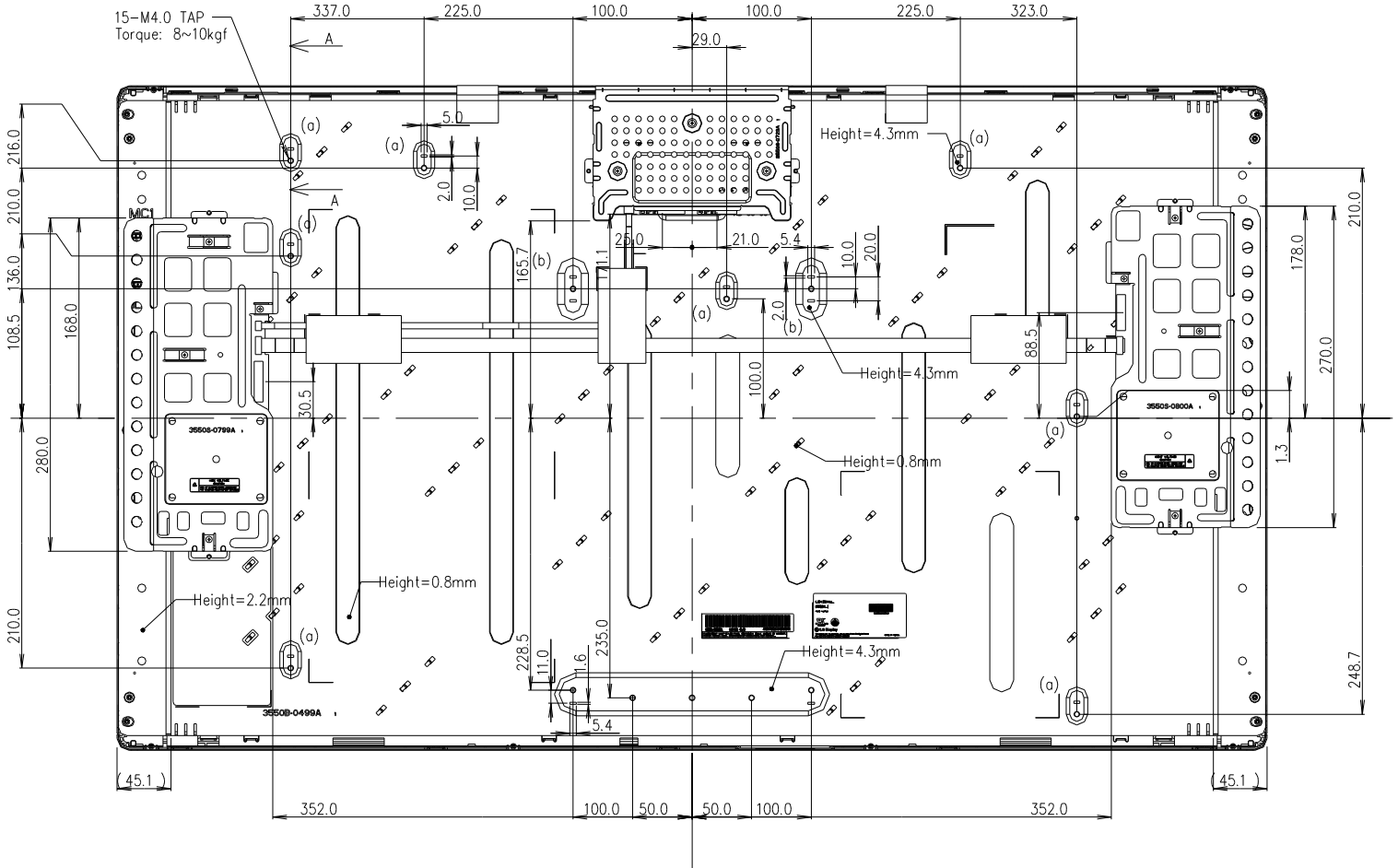

SECTION A-A
SCALE 1/1

Product Specification

6. Reliability**Table 12. ENVIRONMENT TEST CONDITION**

No.	Test Item	Condition
1	High temperature storage test	Ta= 60°C, 75%RH, 240h
2	Low temperature storage test	Ta= -20°C 240h
3	High temperature operation test	Ta= 50°C 60%RH 240h
4	Low temperature operation test	Ta= 0°C 240h
5	Vibration test (non-operating)	Wave form : random Vibration level : 1.0Grms Bandwidth : 10-300Hz Duration : X,Y,Z, 30 min Each direction per 10 min
6	Shock test (non-operating)	Shock level : 50G Waveform : half sine wave, 11ms Direction : ±X, ±Y, ±Z One time each direction
7	Humidity condition Operation	Ta= 40 °C ,90%RH
8	Altitude operating storage / shipment	0 - 15,000 ft 0 - 40,000 ft

Note : Before and after Reliability test, LCM should be operated with normal function.

7. International Standards

7-1. Safety

- a) UL 60065, Seventh Edition, Underwriters Laboratories Inc.
Audio, Video and Similar Electronic Apparatus - Safety Requirements.
- b) CAN/CSA C22.2 No.60065:03, Canadian Standards Association.
Audio, Video and Similar Electronic Apparatus - Safety Requirements.
- c) EN 60065:2002 + A11:2008, European Committee for Electrotechnical Standardization(CENELEC).
Audio, Video and Similar Electronic Apparatus - Safety Requirements.
- d) IEC 60065:2005 + A1:2005, The International Electrotechnical Commission (IEC).
Audio, Video and Similar Electronic Apparatus - Safety Requirements.

7-2. EMC

- a) ANSI C63.4 – 2003 "American National Standard for Methods of Measurement of Radio-Noise Emissions from Low-Voltage Electrical and Electronic Equipment in the Range of 9 kHz to 40 GHz." American National Standards Institute (ANSI), 2003.
- b) C.I.S.P.R. Pub. 22. Limits and methods of measurement of radio interference characteristics of information technology equipment." International Special Committee on Radio Interference (C.I.S.P.R.), 2005.
- c) EN 55022 "Limits and methods of measurement of radio interference characteristics of information technology equipment." European Committee for Electrotechnical Standardization (CENELEC), 2006.

7-3. Environment

- a) RoHS, Directive 2002/95/EC of the European Parliament and of the council of 27 January 2003

Product Specification

8. Packing**8-1. Designation of Lot Mark**

a) Lot Mark

A	B	C	D	E	F	G	H	I	J	K	L	M
---	---	---	---	---	---	---	---	---	---	---	---	---

A,B,C : SIZE(INCH)

E : MONTH

D : YEAR

F ~ M : SERIAL NO.

Note

1. YEAR

Year	2001	2002	2003	2004	2005	2006	2007	2008	2009	2010
Mark	1	2	3	4	5	6	7	8	9	0

2. MONTH

Month	Jan	Feb	Mar	Apr	May	Jun	Jul	Aug	Sep	Oct	Nov	Dec
Mark	1	2	3	4	5	6	7	8	9	A	B	C

b) Location of Lot Mark

Serial No. is printed on the label. The label is attached to the backside of the LCD module.

This is subject to change without prior notice.

8-2. Packing Form

a) Package quantity in one box : 15 pcs

b) Box Size :1140 mm(L) X 990 mm(W) X 810 mm(H)

Product Specification

9. Precautions

Please pay attention to the followings when you use this TFT LCD module.

9-1. Mounting Precautions

- (1) You must mount a module using specified mounting holes (Details refer to the drawings).
- (2) You should consider the mounting structure so that uneven force (ex. Twisted stress) is not applied to the module. And the case on which a module is mounted should have sufficient strength so that external force is not transmitted directly to the module.
- (3) Please attach the surface transparent protective plate to the surface in order to protect the polarizer. Transparent protective plate should have sufficient strength in order to resist external force.
- (4) You should adopt radiation structure to satisfy the temperature specification.
- (5) Acetic acid type and chlorine type materials for the cover case are not desirable because the former generates corrosive gas of attacking the polarizer at high temperature and the latter causes circuit break by electro-chemical reaction.
- (6) Do not touch, push or rub the exposed polarizers with glass, tweezers or anything harder than HB pencil lead. And please do not rub with dust clothes with chemical treatment. Do not touch the surface of polarizer for bare hand or greasy cloth. (Some cosmetics are detrimental to the polarizer.)
- (7) When the surface becomes dusty, please wipe gently with absorbent cotton or other soft materials like chamois soaks with petroleum benzene. Normal-hexane is recommended for cleaning the adhesives used to attach front / rear polarizers. Do not use acetone, toluene and alcohol because they cause chemical damage to the polarizer.
- (8) Wipe off saliva or water drops as soon as possible. Their long time contact with polarizer causes deformations and color fading.
- (9) Do not open the case because inside circuits do not have sufficient strength.
- (10) If there is external force to LCM, it can effect to bend the slim. Since the bending, Lamp Mura can be shown on display.

9-2. Operating Precautions

- (1) The spike noise causes the mis-operation of circuits. It should be lower than following voltage :
 $V = \pm 200\text{mV}$ (Over and under shoot voltage)
- (2) Response time depends on the temperature. (In lower temperature, it becomes longer.)
- (3) Brightness depends on the temperature. (In lower temperature, it becomes lower.)
 And in lower temperature, response time (required time that brightness is stable after turned on) becomes longer.
- (4) Be careful for condensation at sudden temperature change. Condensation makes damage to polarizer or electrical contacted parts. And after fading condensation, smear or spot will occur.
- (5) When fixed patterns are displayed for a long time, remnant image is likely to occur.
- (6) Module has high frequency circuits. Sufficient suppression to the electromagnetic interference shall be done by system manufacturers. Grounding and shielding methods may be important to minimized the interference.
- (7) Please do not give any mechanical and/or acoustical impact to LCM. Otherwise, LCM can't be operated its full characteristics perfectly.
- (8) A screw which is fastened up the steels should be a machine screw.
 (if not, it causes metallic foreign material and deal LCM a fatal blow)
- (9) Please do not set LCD on its edge.
- (10) It is recommended to avoid the signal cable and conductive material over the inverter transformer for it can cause the abnormal display and temperature rising.
- (11) Partial darkness may happen during 3~5 minutes when LCM is operated initially in condition that luminance is under 40% at low temperature (under 5°C). This phenomenon which disappears naturally after 3~5 minutes is not a problem about reliability but LCD characteristic.

Product Specification

9-3. Electrostatic Discharge Control

Since a module is composed of electronic circuits, it is not strong to electrostatic discharge. Make certain that treatment persons are connected to ground through wrist band etc. And don't touch interface pin directly.

9-4. Precautions for Strong Light Exposure

Strong light exposure causes degradation of polarizer and color filter.

9-5. Storage

When storing modules as spares for a long time, the following precautions are necessary.

- (1) Store them in a dark place. Do not expose the module to sunlight or fluorescent light. Keep the temperature between 5°C and 35°C at normal humidity.
- (2) The polarizer surface should not come in contact with any other object.
It is recommended that they be stored in the container in which they were shipped.

9-6. Handling Precautions for Protection Film

- (1) The protection film is attached to the bezel with a small masking tape.
When the protection film is peeled off, static electricity is generated between the film and polarizer.
This should be peeled off slowly and carefully by people who are electrically grounded and with well ion-blown equipment or in such a condition, etc.
- (2) When the module with protection film attached is stored for a long time, sometimes there remains a very small amount of glue still on the bezel after the protection film is peeled off.
- (3) You can remove the glue easily. When the glue remains on the bezel surface or its vestige is recognized, please wipe them off with absorbent cotton waste or other soft material like chamois soaked with normal-hexane.

Product Specification

APPENDIX- I-1

■ Required signal assignment for Flat Link (Thine : THC63LVD103) Transmitter (Pin7="L")

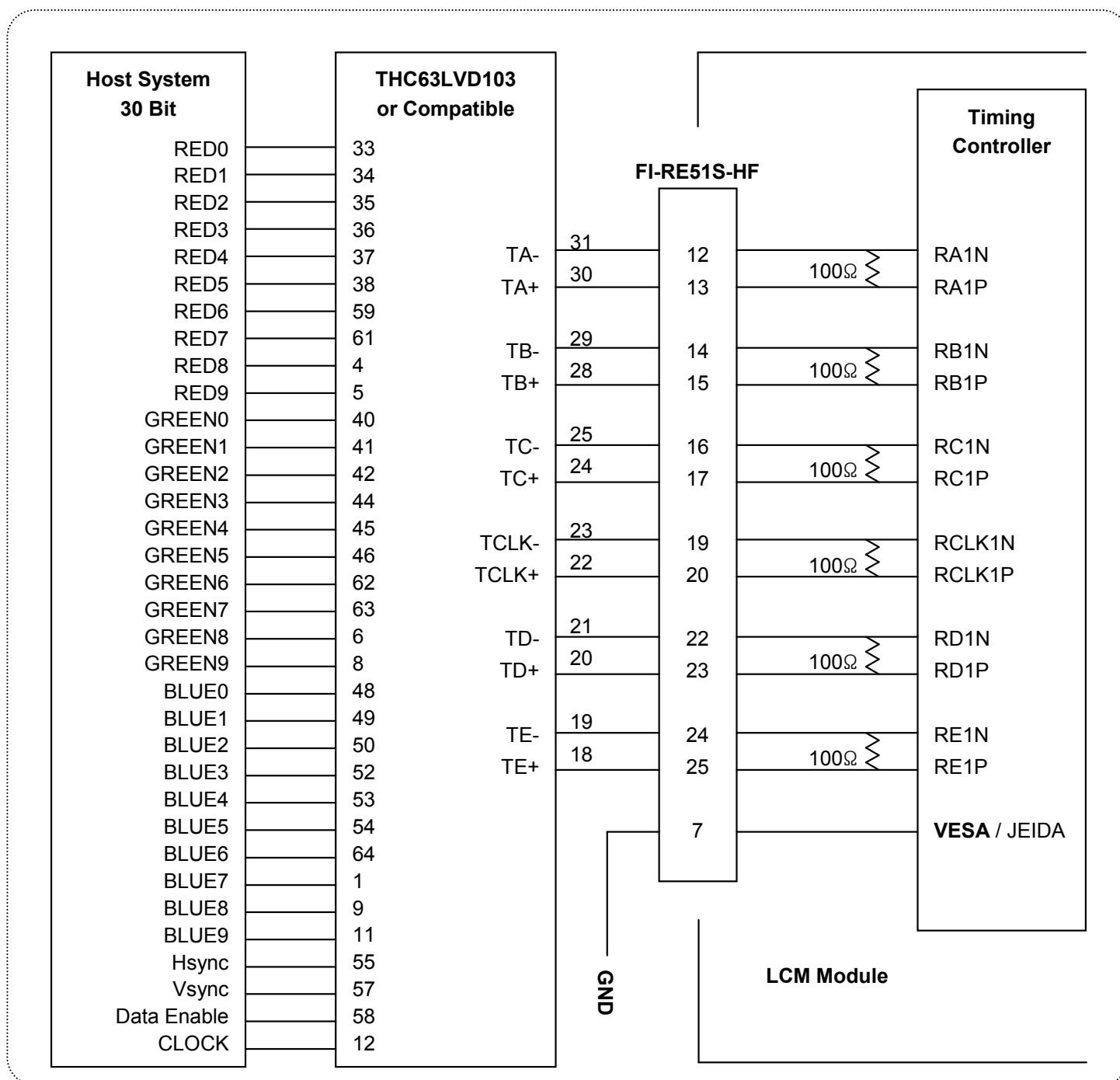

Notes:

1. The LCD module uses a 100 Ohm(Ω) resistor between positive and negative lines of each receiver input.
2. Refer to LVDS transmitter data sheet for detail descriptions. (THC63LVD103 or Compatible)
3. '9' means MSB and '0' means LSB at R,G,B pixel data.

Product Specification

APPENDIX- 1-2

■ Required signal assignment for Flat Link (Thine : THC63LVD103) Transmitter (Pin7="H")

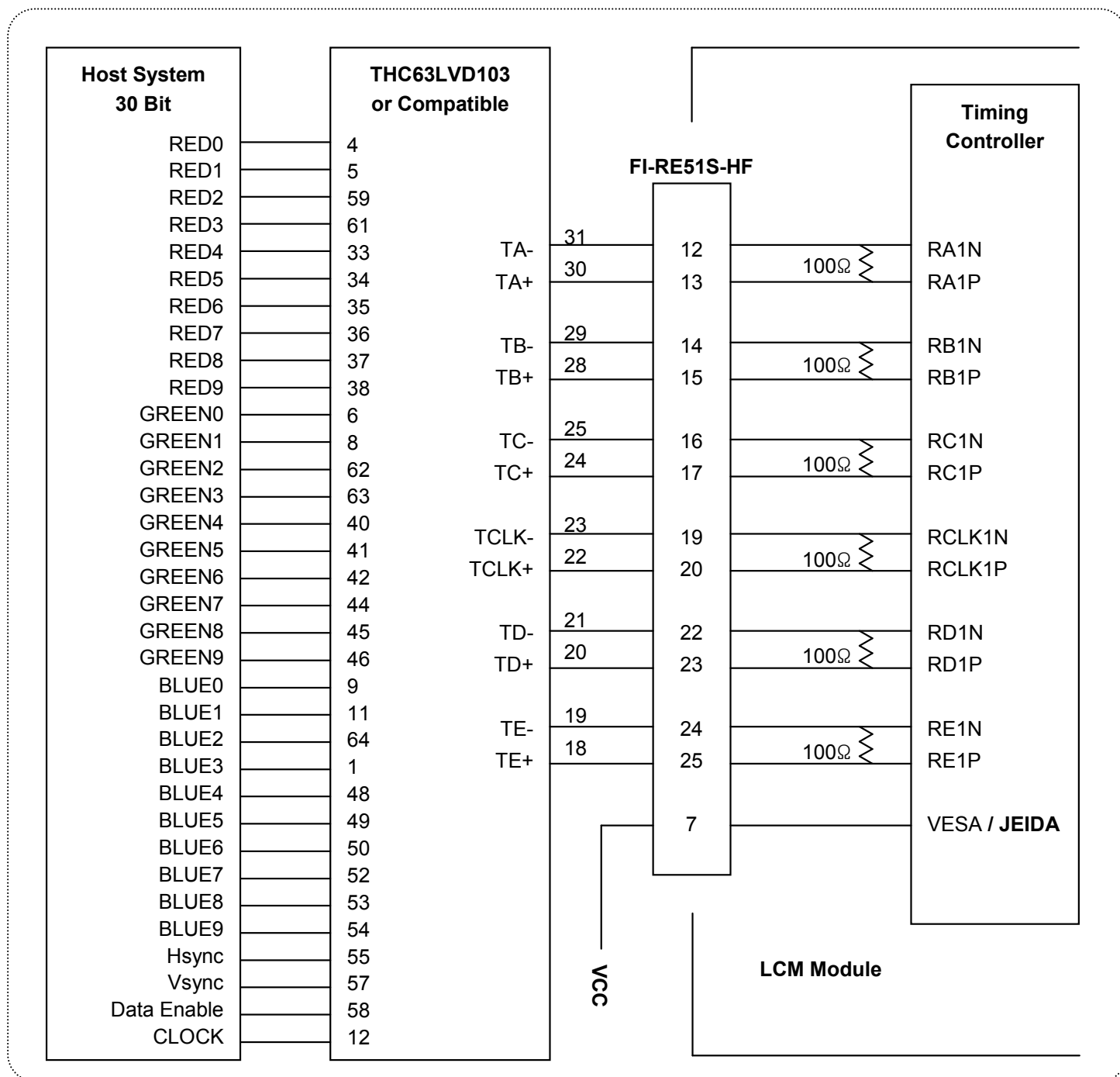

Notes:

1. The LCD module uses a 100 Ohm(Ω) resistor between positive and negative lines of each receiver input.
2. Refer to LVDS transmitter data sheet for detail descriptions. (THC63LVD103 or Compatible)
3. '9' means MSB and '0' means LSB at R,G,B pixel data.

Product Specification

APPENDIX-II
 ■ Pallet Ass'y

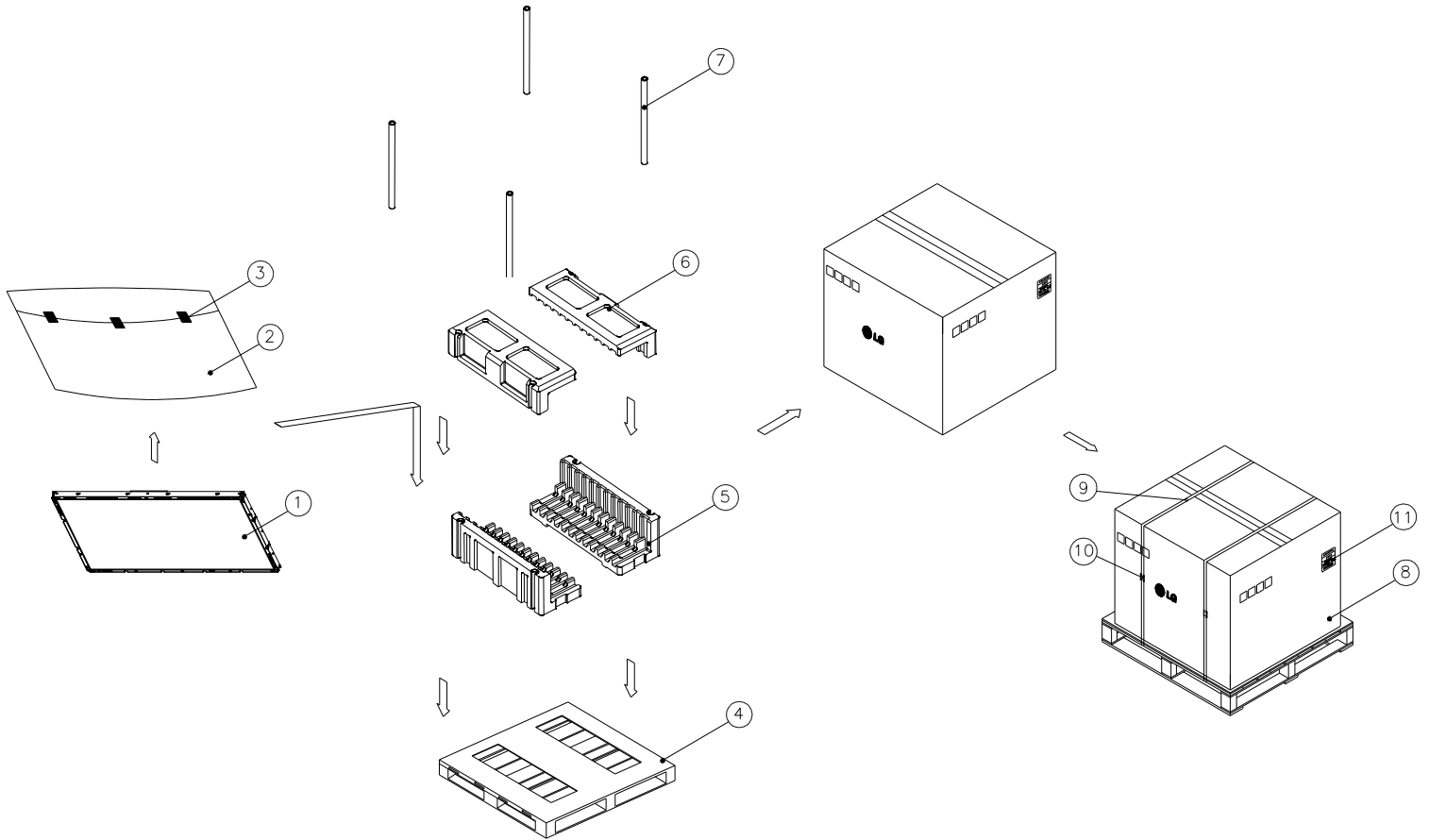

NO.	DESCRIPTION	MATERIAL
1	LCD Module	
2	BAG	42INCH
3	TAPE	MASKING 20MM X 50M
4	PALLET	Plywood(1140X990X117.5)
5	PACKING	EPS
6	PACKING	EPS
7	ANGLE_POST	PAPER
8	ANGLE PACKING	PAPER
9	BAND	PP
10	BAND,CLIP	STEEL
11	LABEL	YUPO PAPER 80G 100X70

APPENDIX- III

■ LCM Label

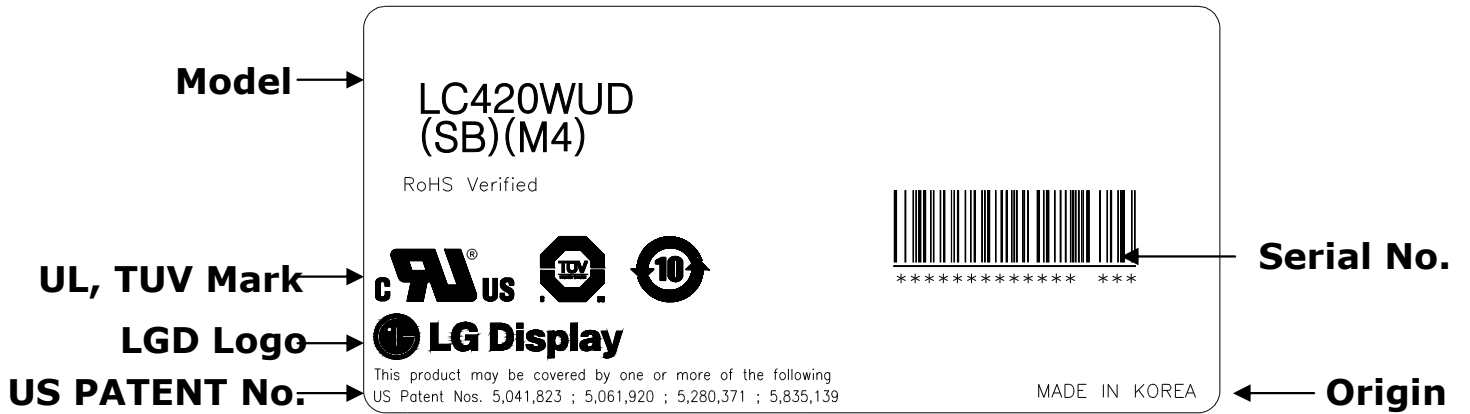

APPENDIX- IV

■ Pallet Label



Product Specification

APPENDIX-V

Scanning and OPC Design Guide

- 1) When OPC Enable is "L", SCAN_BLK1 & SCAN_BLK2 = System Dimming with 100Hz or 120Hz frequency.
- 2) SCAN_BLK1 & SCAN_BLK2 signals are synchronized with V-Sync Freq. of System in T-Con Board.
- 3) Regardless of OPC, System should always give dimming Signal (**EXTV_{BR-B}**) to T-con during operation.
- 4) EXTV_{BR-B} Specification (VCC = 3.3V) @ OPC
 - a) High Voltage Range : 2.5 V ~ 3.6 V
 - b) Low Voltage Range : 0.0 V ~ 0.8 V

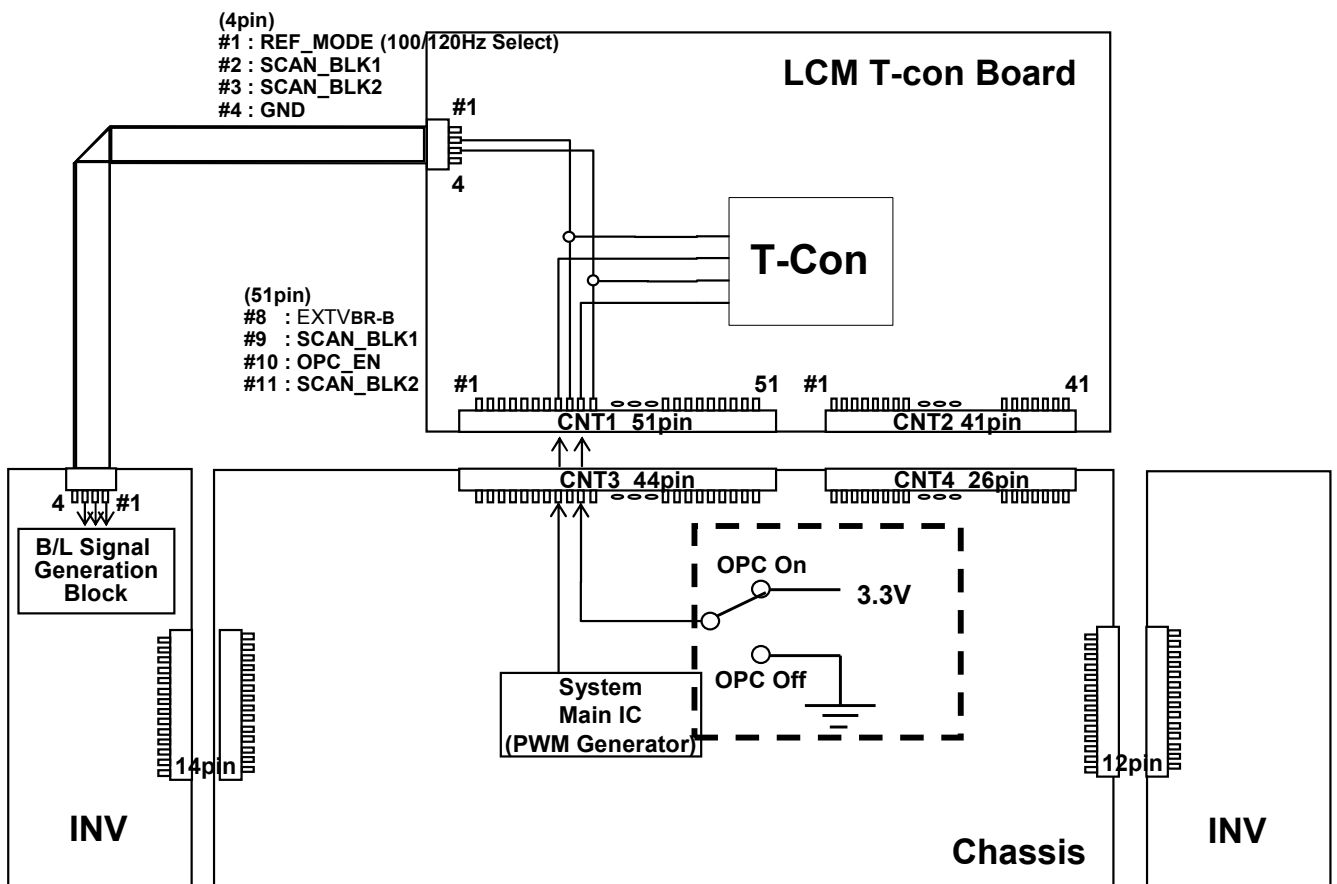

<With Inverter Model>

Input Frequency	MAX 1Khz (Recommendation:50~300Hz)
Rising Time	MAX 10.0 μs
Falling Time	MAX 10.0 μs

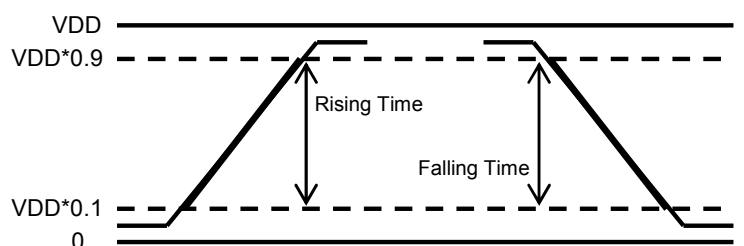

Product Specification

APPENDIX-VI

Inverter 14th Pin (Status) Design Guide

□ Function of Status pin

- Purpose : Preventing of backlight off by restarting the inverter technically
- How to : When inverter is abnormal operation, TV system inputs the Von signal in the inverter once more to turn on the lamp safely
- Attention : Restart system's Von signal when status pin is high for some time (min:1sec , max:4sec).
(The turn on time of lamp can be late such as the low temperature or the storage time)

□ Status operation modes in TV set

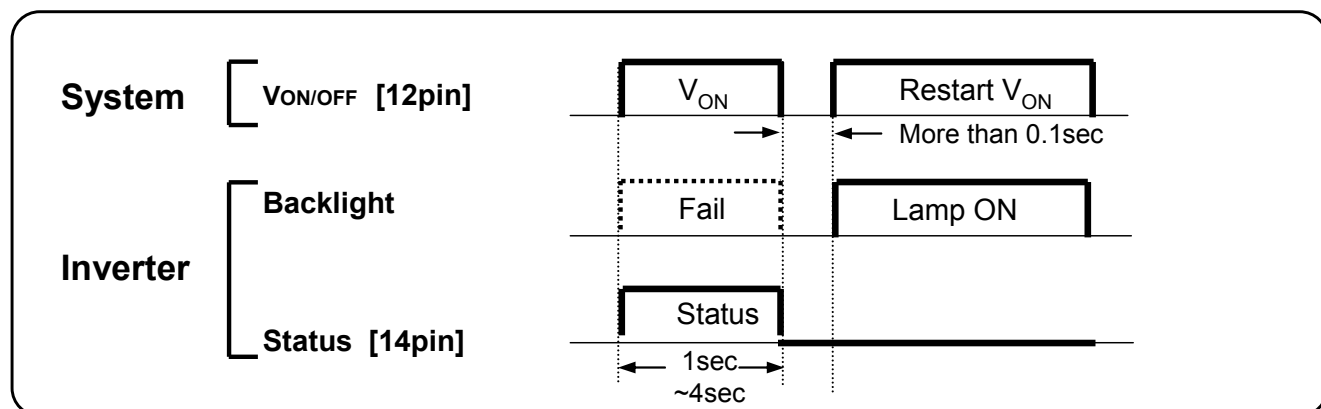
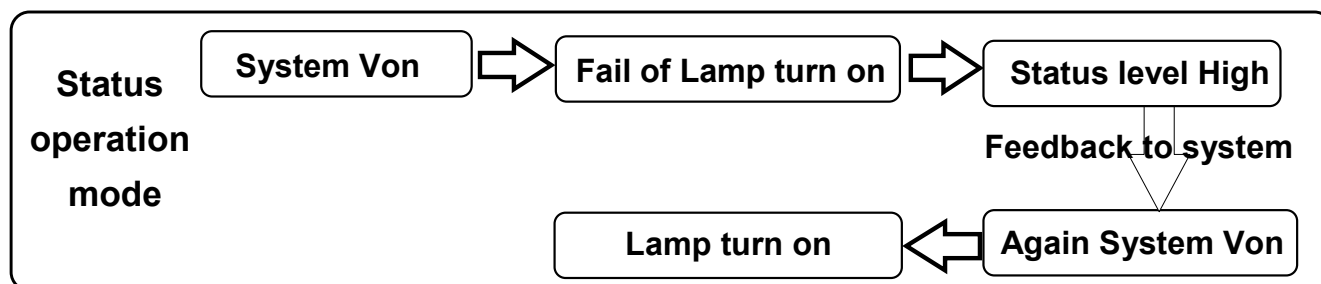
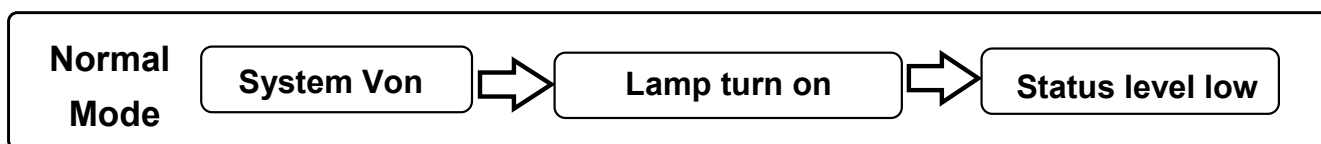

□ Inverter pin map

Pin No	Symbol	Description	Inv.
11	VBR-A	Analog dimming voltage DC 0.0V ~ 3.3V (Typ : 1.65V)	VBR-A
12	VON/OFF	0.0V ~ 5.0V	On/Off
13	NC	NC	
14	Status	Normal : Under 0.7V Abnormal : Upper 3.0V	status

APPENDIX- VII-1

Option Pin Circuit Block Diagram

Circuit Block Diagram of LVDS Format Selection pin

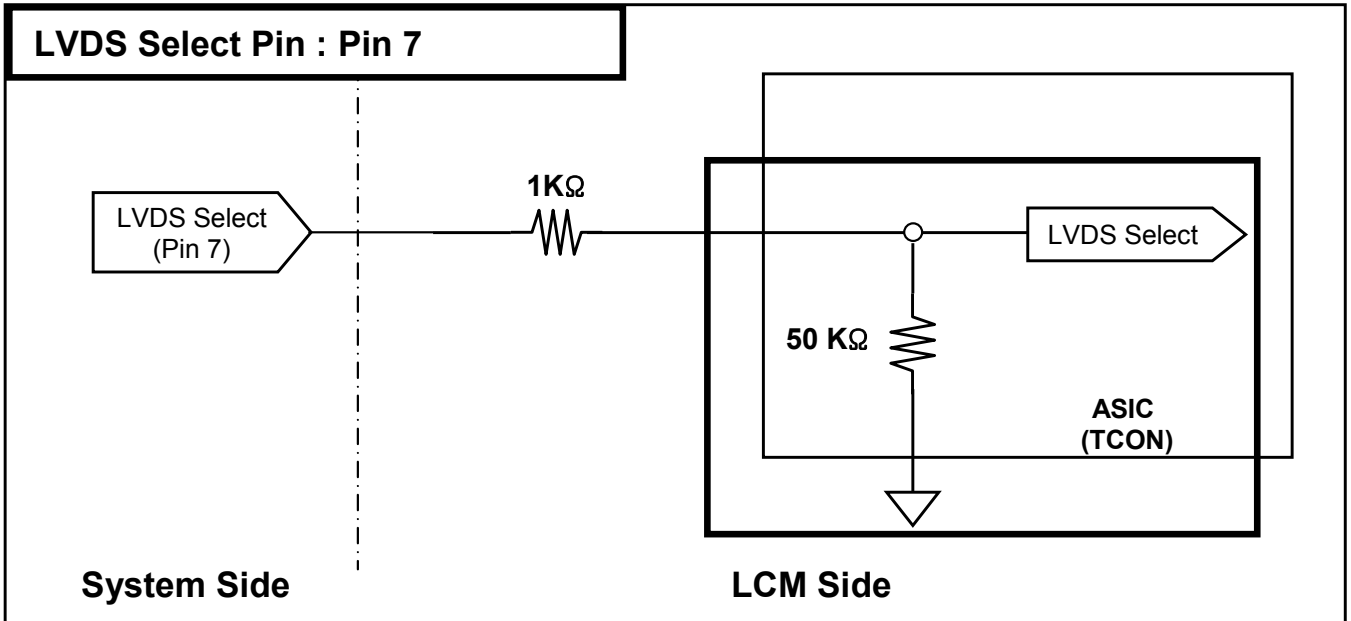

Circuit Block Diagram of Bit Selection pin

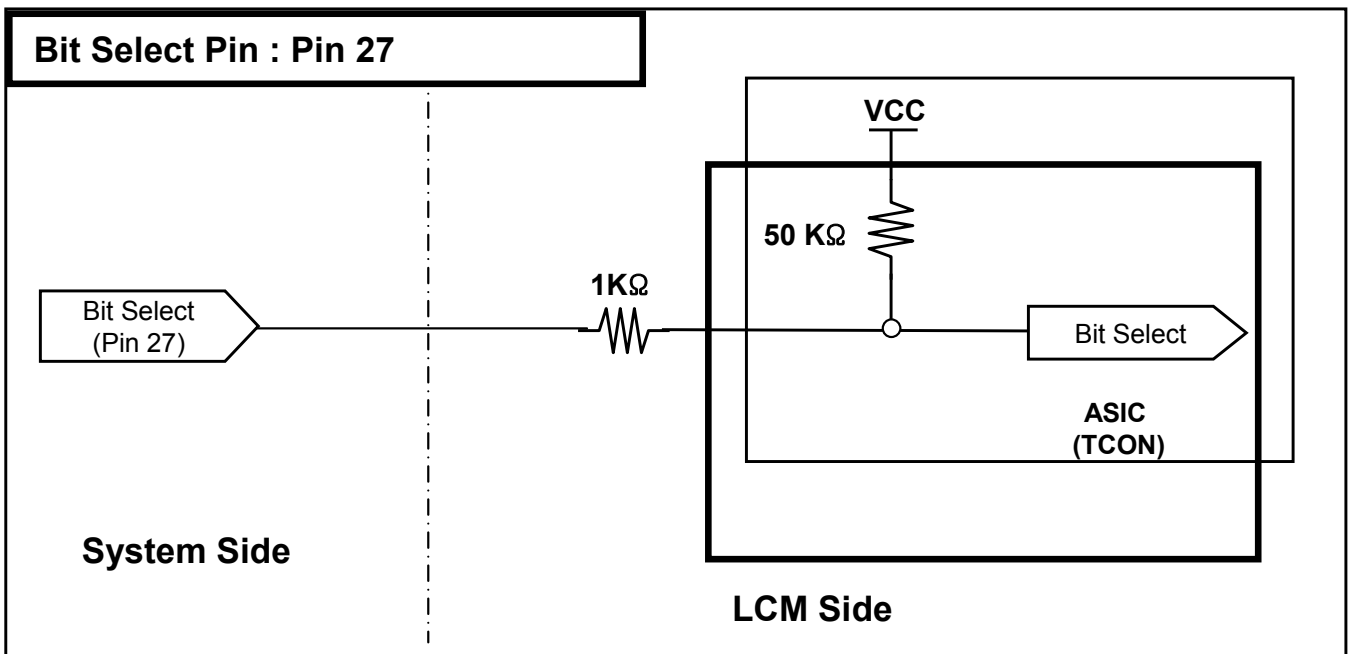

APPENDIX- VII-2

Option Pin Circuit Block Diagram

Circuit Block Diagram of OPC Enable Selection pin

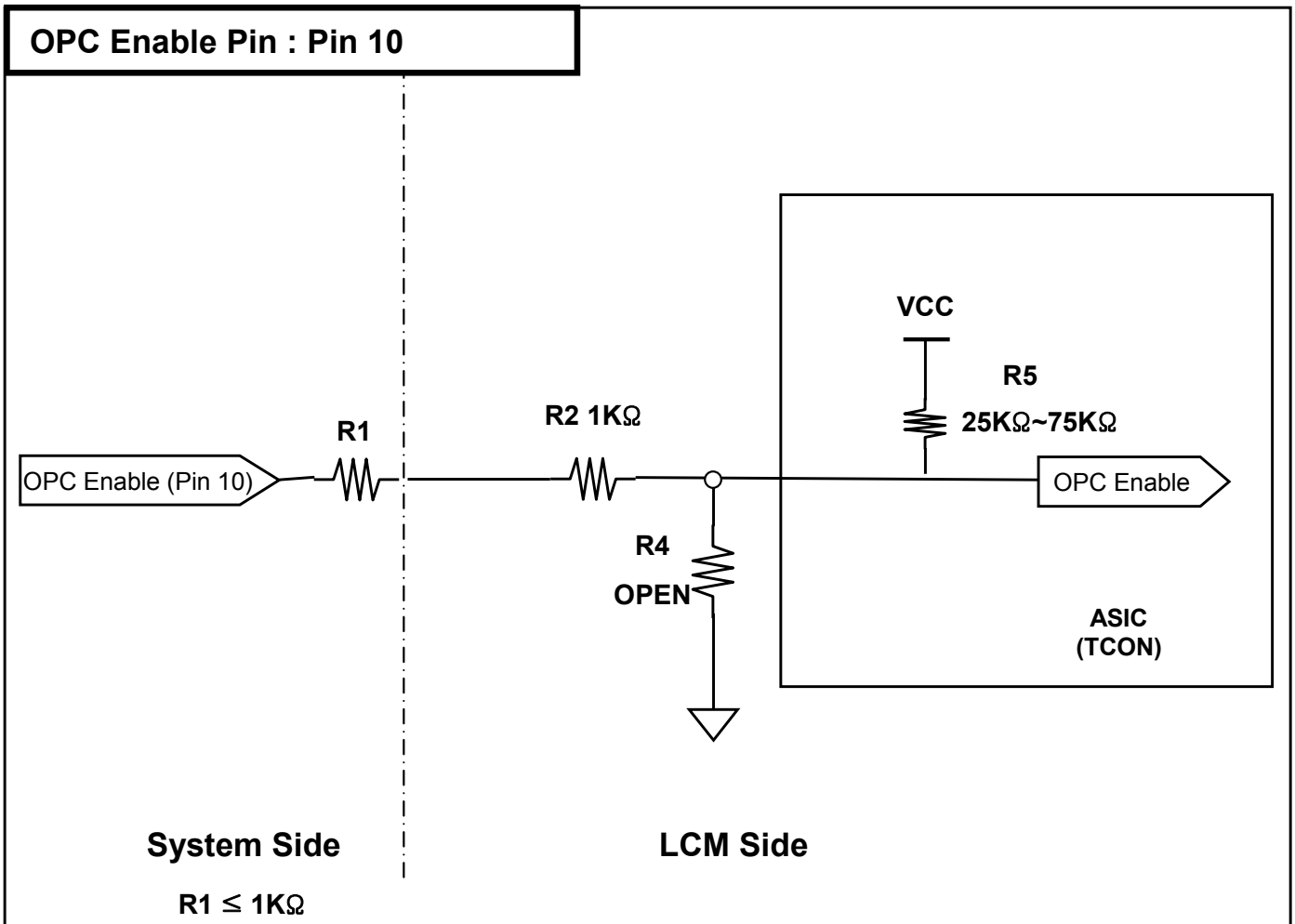

Product Specification

APPENDIX- VIII-1

LVDS Input characteristics

1. DC Specification

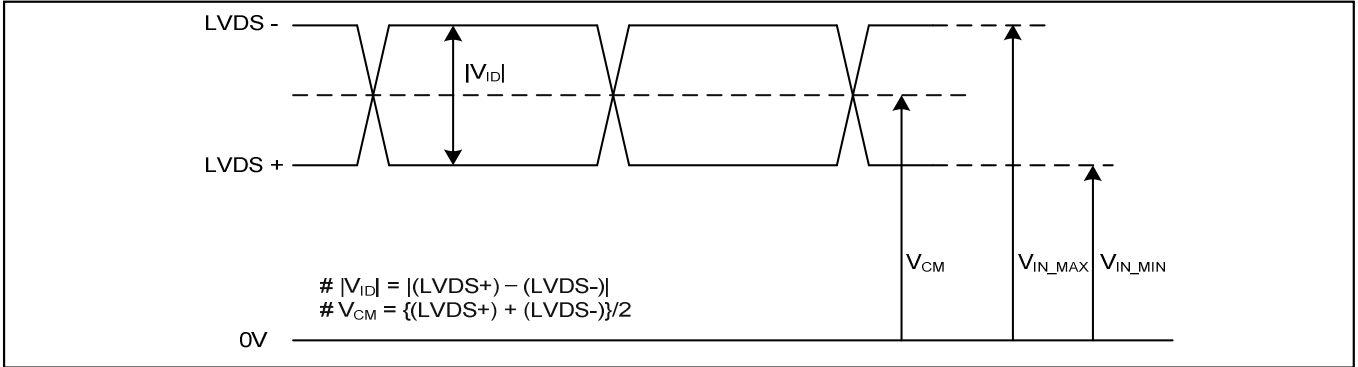

Description	Symbol	Min	Max	Unit	Notes
LVDS Single end Voltage	$ V_{ID} $	200	600	mV	-
LVDS Common mode Voltage	V_{CM}	1.1	1.5	V	-
LVDS Input Voltage Range	V_{IN}	0.7	1.8	V	-
Change in common mode Voltage	ΔV_{CM}		250	mV	-

2. AC Specification

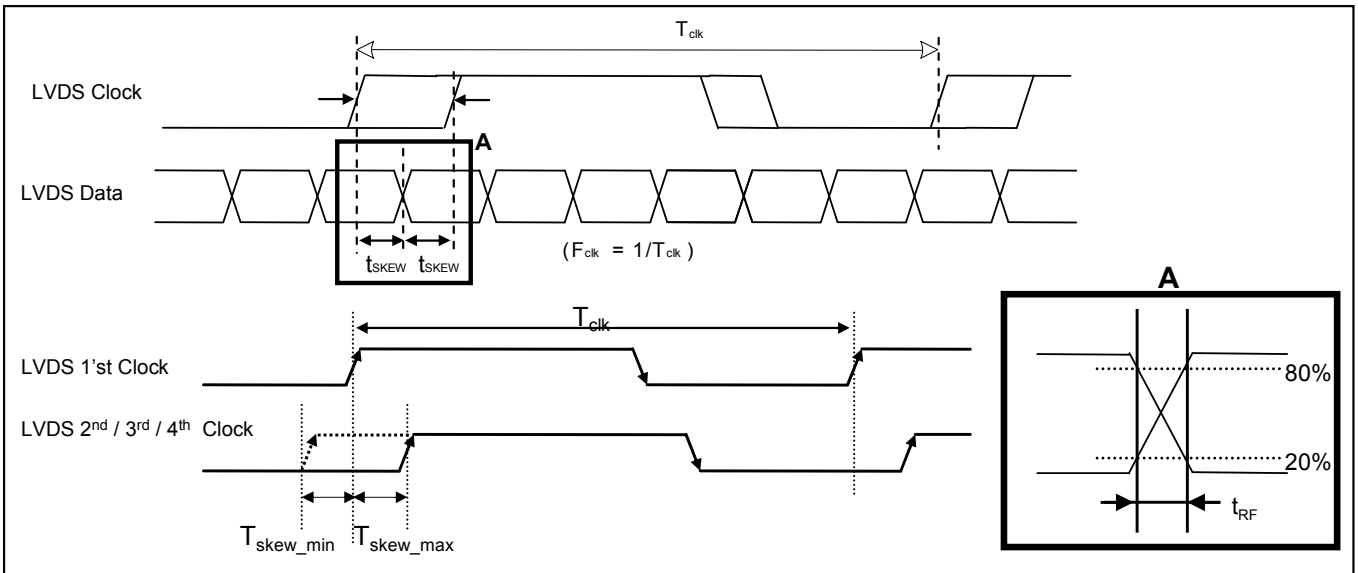

Description	Symbol	Min	Max	Unit	Notes
LVDS Clock to Data Skew Margin	t_{SKEW}		480	ps	$78MHz > F_{clk} \geq 70MHz$
LVDS Clock/DATA Rising/Falling time	t_{RF}	260	$(0.3 * T_{clk}) / 7$	ps	-
LVDS Clock to Clock Skew Margin (Even to Odd)	t_{SKEW_EO}		$1/7 * T_{clk}$	T_{clk}	-

Note. All Input levels of LVDS signals are based on the EIA 644 Standard.

APPENDIX- VIII-2

LVDS Input characteristics

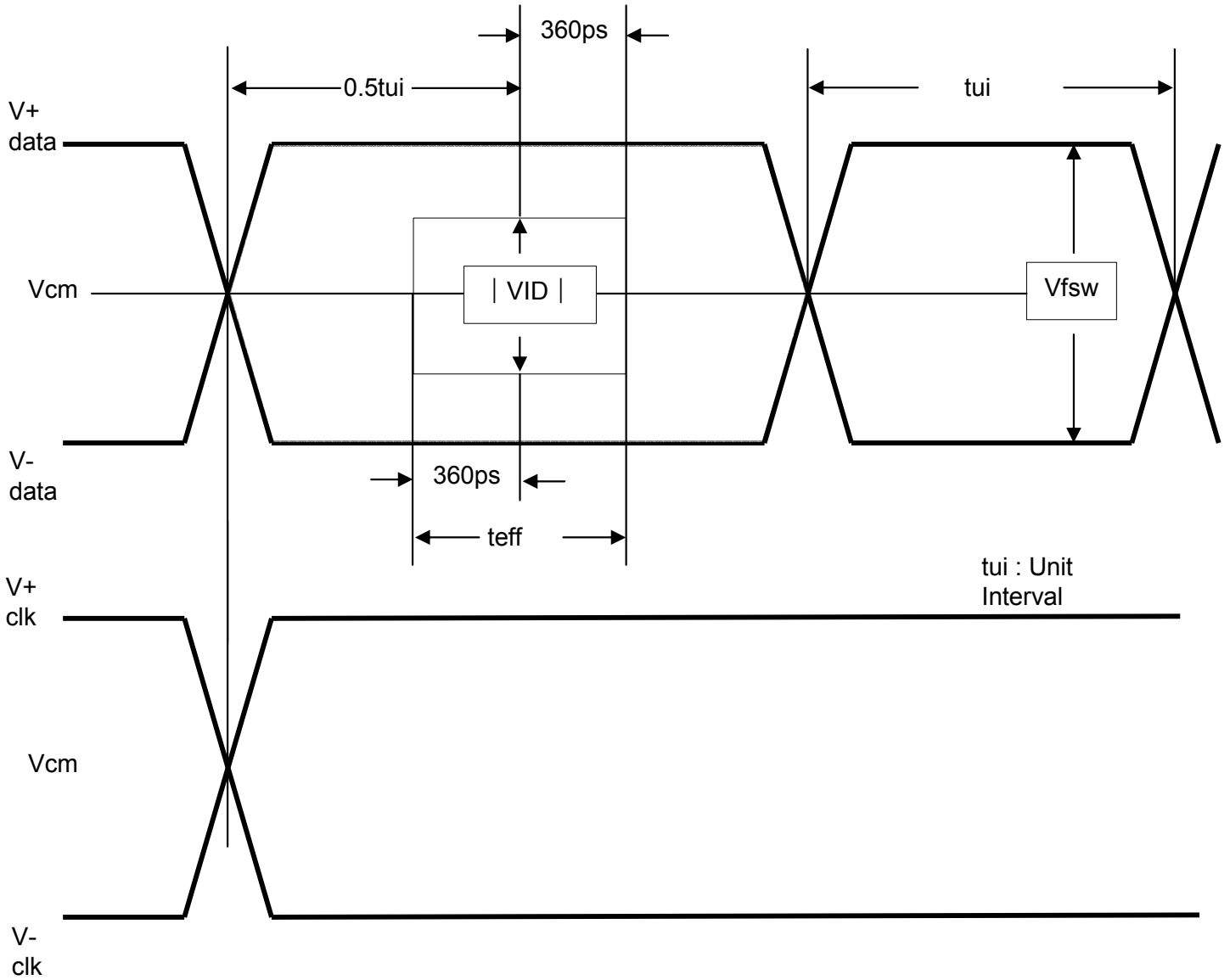

APPENDIX- IX-1

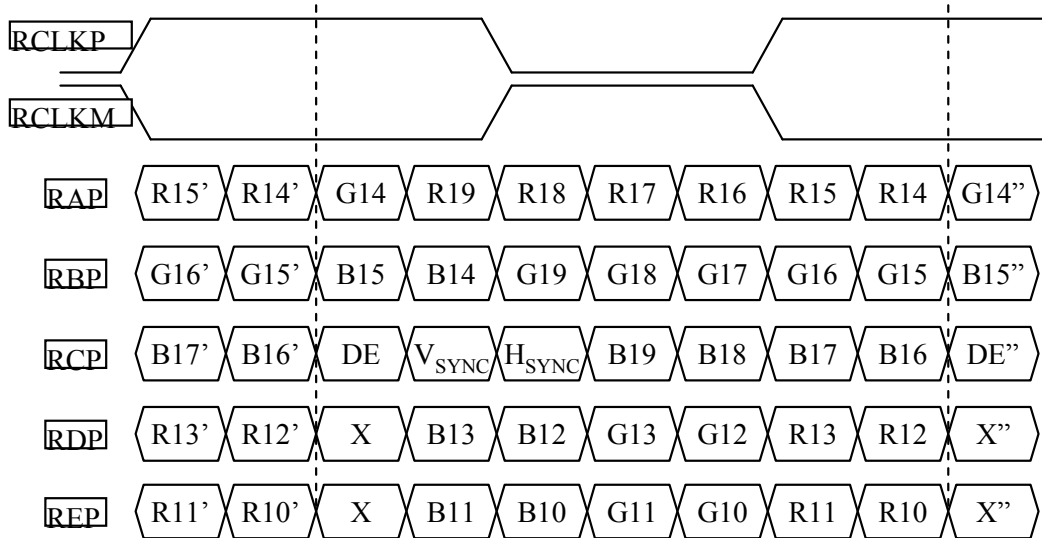
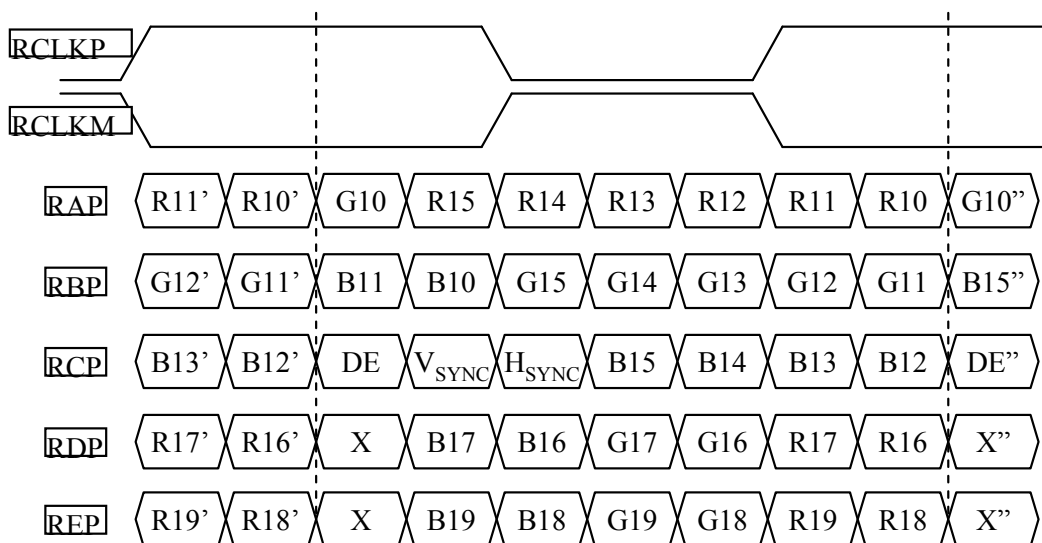
LVDS Data-Mapping info. (10bit)**■ LVDS Select : “H” Data-Mapping (JEIDA format)****■ LVDS Select : “L” Data-Mapping (VESA format)**

APPENDIX- IX-2

LVDS Data-Mapping info. (8bit)

■ LVDS Select : “H” Data-Mapping (JEIDA format)

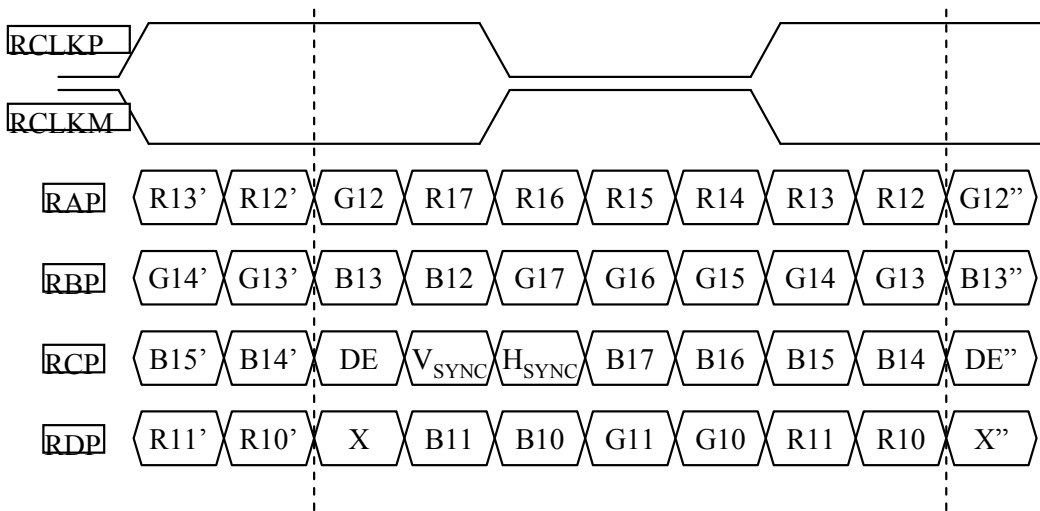

■ LVDS Select : “L” Data-Mapping (VESA format)

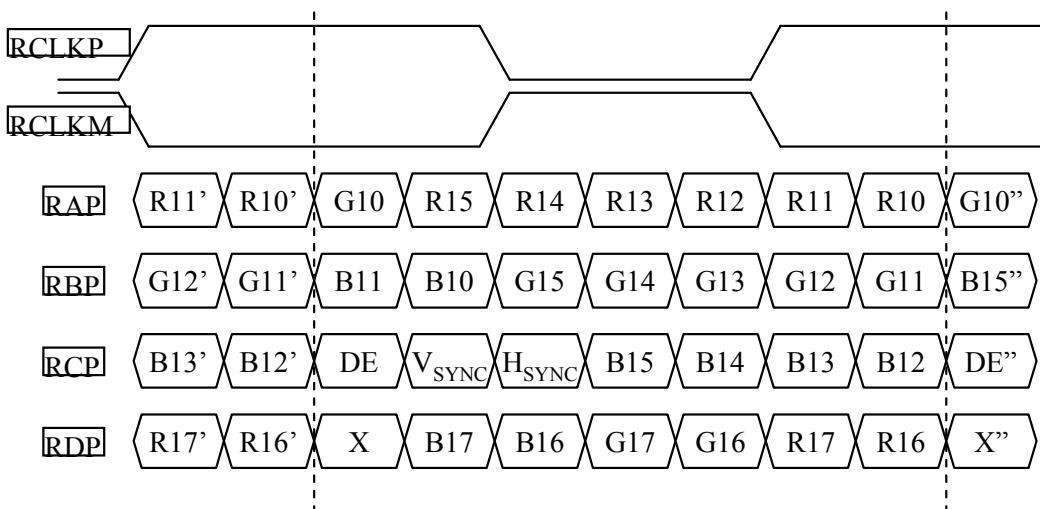

APPENDIX- X-1

Mega DCR using condition(1)

- After Inverter ON signal, PWM Duty 100% should be sustained during 2sec.
- It is recommended not to sustain more than 10 min for Deep Dimming (PWM Low Duty 0%~20%).

The deep dimming must be used very carefully due to limitation of lamp characteristics and specification.

- 1) For stable lamp on, its duty condition should follow below the condition.
After Inverter ON signal, T0 duration should be sustained.

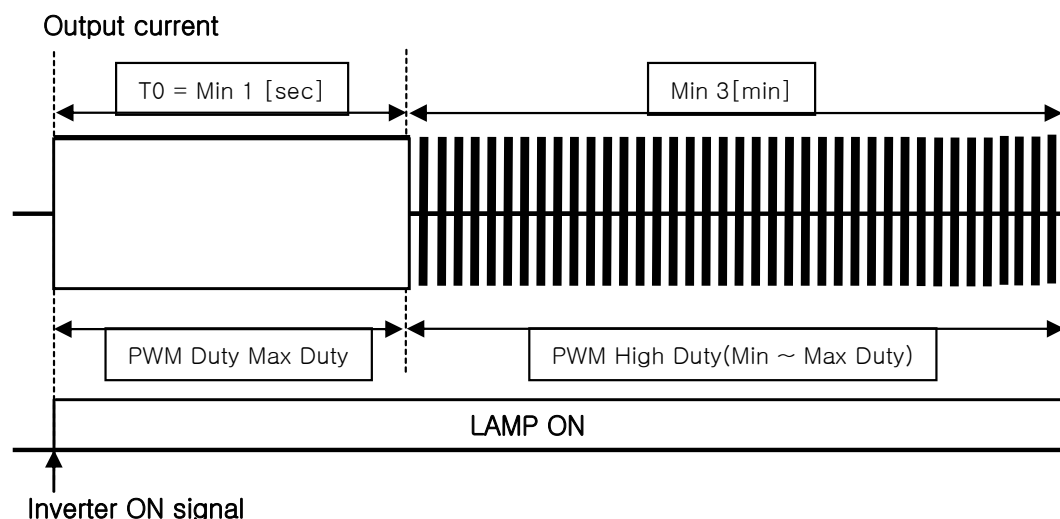

- 2) Low duty(0%~Min duty) of **the inverter output current**, B/L may not satisfy some of LCM specification.

- Duration : the low duty operation(0% ~ Min duty) must be limited within 10 minutes for one time operation.
- Ratio : the period of the low duty operation must be less than 1/5 compare to that of the high duty operation(Min~Max Duty) in a certain period to prevent unwanted operation.
- FOS : partial darkness or darkness of center area during the low duty might be happened due to insufficient lamp current.
- Warm up : the low duty must be used 3 min after the lamps "ON". In case of low temperature, more warm up time may be needed.

APPENDIX- X-2

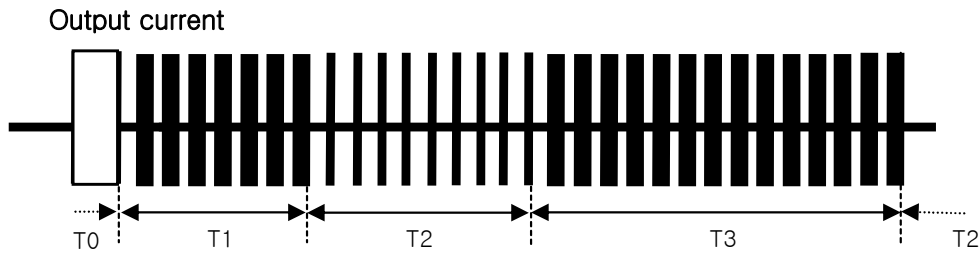
Mega DCR using condition(2)

Parameter	Value			Unit	Note
	Min	Typ	Max		
T1	3	-	-	min	Min ~ Max Duty
T2	-	-	10	min	0% ~ Min Duty
T3	T2 x 5	-	-	min	Min ~ Max Duty

- 3) The output current duty may not be same as input PWM duty due to rise/fall time of output.
- 4) Following the recommended conditions as mentioned, there is no difference of lamp lifetime between conventional method and new one.