



LC420WUN

## Product Specification

# SPECIFICATION FOR APPROVAL

( ) Preliminary Specification

(●) Final Specification

Title	42.0" WUXGA TFT LCD
-------	---------------------

BUYER	General
MODEL	

SUPPLIER	LG Display Co., Ltd.
*MODEL	LC420WUN
SUFFIX	SDA2

\*When you obtain standard approval,  
please use the above model name without suffix

APPROVED BY	SIGNATURE DATE
/	
/	
/	

Please return 1 copy for your confirmation with your signature and comments.

APPROVED BY	SIGNATURE DATE
O. H. Lee / Team Leader	
<b>REVIEWED BY</b>	
H. S. LEE / Project Leader	
<b>PREPARED BY</b>	
S. B. Lee / Engineer	

**TV Products Development Dept.  
LG Display LCD Co., Ltd**

LC420WUN

## Product Specification

**CONTENTS**

Number	ITEM	Page
	COVER	1
	CONTENTS	2
	RECORD OF REVISIONS	3
1	GENERAL DESCRIPTION	4
2	ABSOLUTE MAXIMUM RATINGS	5
3	ELECTRICAL SPECIFICATIONS	6
3-1	ELECTRICAL CHARACTERISTICS	6
3-2	INTERFACE CONNECTIONS	8
3-3	SIGNAL TIMING SPECIFICATIONS	10
3-4	LVDS SIGNAL SPECIFICATIONS	11
3-5	COLOR DATA REFERENCE	14
3-6	POWER SEQUENCE	15
4	OPTICAL SPECIFICATIONS	17
5	MECHANICAL CHARACTERISTICS	21
6	RELIABILITY	24
7	INTERNATIONAL STANDARDS	25
7-1	SAFETY	25
7-2	EMC	25
7-3	Environment	25
8	PACKING	26
8-1	INFORMATION OF LCM LABEL	26
8-2	PACKING FORM	26
9	PRECAUTIONS	27
9-1	MOUNTING PRECAUTIONS	27
9-2	OPERATING PRECAUTIONS	27
9-3	ELECTROSTATIC DISCHARGE CONTROL	28
9-4	PRECAUTIONS FOR STRONG LIGHT EXPOSURE	28
9-5	STORAGE	28
9-6	HANDLING PRECAUTIONS FOR PROTECTION FILM	28



## Product Specification

## 1. General Description

The LC420WUN is a Color Active Matrix Liquid Crystal Display with an integral External Electrode Fluorescent Lamp (EEFL) backlight system. The matrix employs a-Si Thin Film Transistor as the active element. It is a transmissive display type which is operating in the normally black mode. It has a 42.02 inch diagonally measured active display area with WUXGA resolution (1080 vertical by 1920 horizontal pixel array). Each pixel is divided into Red, Green and Blue sub-pixels or dots which are arrayed in vertical stripes. Gray scale or the luminance of the sub-pixel color is determined with a 10-bit gray scale signal for each dot. Therefore, it can present a palette of more than 1.06Billion (FRC) colors.

It has been designed to apply the 10-bit 2-port LVDS interface.

It is intended to support LCD TV, PCTV where high brightness, super wide viewing angle, high color gamut, high color depth and fast response time are important.

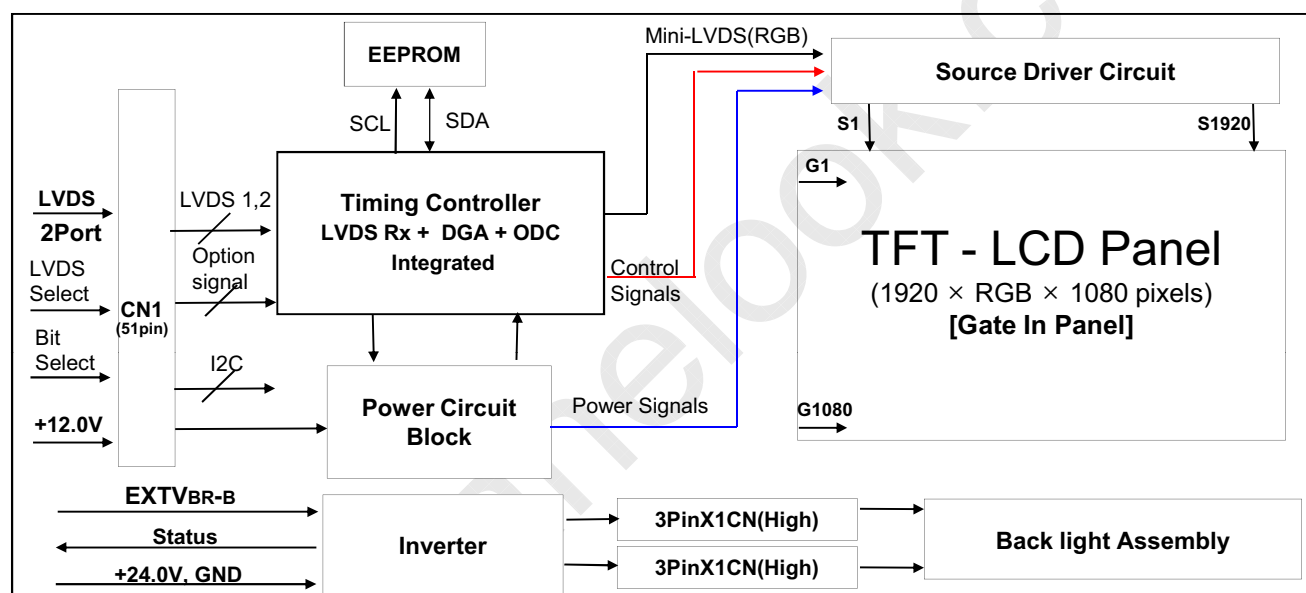

## General Features

Active Screen Size	42.02 inches(1067.31mm) diagonal
Outline Dimension	983.0(H) x 576.0 (V) x 51.0 mm(D) (Typ.)
Pixel Pitch	0.4845 mm x 0.4845 mm
Pixel Format	1920 horiz. by 1080 vert. Pixels, RGB stripe arrangement
Color Depth	10bit(D) , 1.06Billion colors
Luminance, White	400 cd/m <sup>2</sup> (Center 1point ,Typ.)
Viewing Angle (CR>10)	Viewing angle free ( R/L 178 (Min.), U/D 178 (Min.))
Power Consumption	Total 156.8 W (Typ.) (Logic=7.8W, Inverter=149W )
Weight	9.1 Kg (Typ.)
Display Mode	Transmissive mode, Normally black
Surface Treatment	Hard coating(3H), Anti-glare treatment of the front polarizer (Haze 10%)

LC420WUN

## Product Specification

## 2. Absolute Maximum Ratings

The following items are maximum values which, if exceeded, may cause faulty operation or damage to the LCD module.

**Table 1. ABSOLUTE MAXIMUM RATINGS**

Parameter		Symbol	Value		Unit	Note
			Min	Max		
Power Input Voltage	LCD Circuit	VLCD	-0.3	+14.0	VDC	
	Inverter	VBL	-0.3	+ 27.0	VDC	
Inverter Control Voltage	ON/OFF	VOFF / VON	-0.3	+5.5	VDC	1
	Brightness	VBR	0.0	+5.0	VDC	
T-Con Option Selection Voltage		VLOGIC	-0.3	+4.0	VDC	
Operating Temperature		TOP	0	+50	°C	2,3
Storage Temperature		TST	-20	+60	°C	
Panel Front Temperature		TSUR	-	+68	°C	4
Operating Ambient Humidity		HOP	10	90	%RH	2,3
Storage Humidity		HST	10	90	%RH	

Note1. Ambient temperature condition ( $T_a = 25 \pm 2 \text{ }^\circ\text{C}$ )

2. Temperature and relative humidity range are shown in the figure below.

Wet bulb temperature should be Max  $39^\circ\text{C}$ , and no condensation of water.

3. Gravity mura can be guaranteed below  $40^\circ\text{C}$  condition.

4. The maximum operating temperatures is based on the test condition that the surface temperature of display area is less than or equal to  $68^\circ\text{C}$  with LCD module alone in a temperature controlled chamber. Thermal management should be considered in final product design to prevent the surface temperature of display area from being over  $68^\circ\text{C}$ . The range of operating temperature may degraded in case of improper thermal management in final product design.

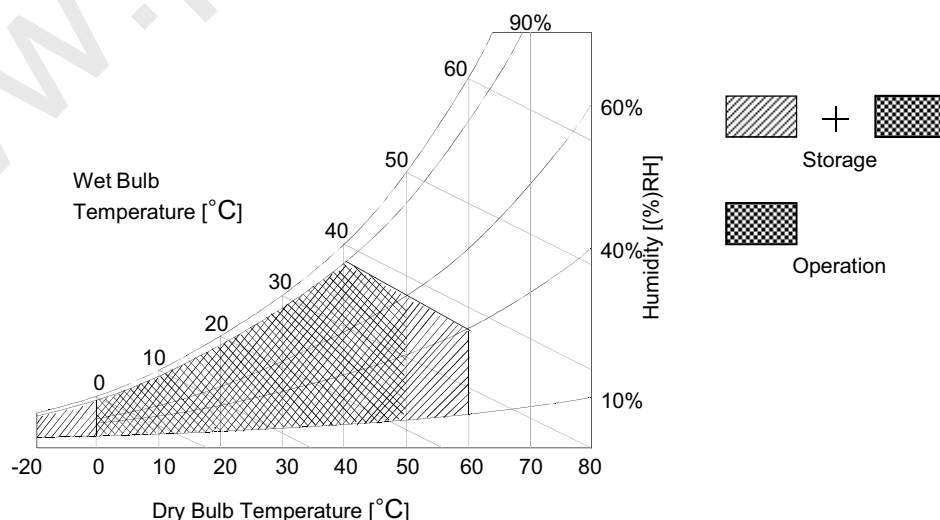

LC420WUN

## Product Specification

### 3. Electrical Specifications

#### 3-1. Electrical Characteristics

It requires two power inputs. One is employed to power for the LCD circuit. The other is used for the EEFL backlight and inverter circuit.

**Table 2. ELECTRICAL CHARACTERISTICS**

Parameter	Symbol	Value			Unit	Note
		Min	Typ	Max		
<b>Circuit :</b>						
Power Input Voltage	V <sub>LCD</sub>	10.8	12.0	13.2	V <sub>DC</sub>	
Power Input Current (TBD)	I <sub>LCD</sub>	455	650	845	mA	1
		668	955	1240	mA	2
Power Consumption	P <sub>LCD</sub>		7.8	9.2	Watt	1
Rush current	I <sub>RUSH</sub>	-	-	3.0	A	3

Note 1. The specified current and power consumption are under the  $V_{LCD}=12.0V$ ,  $T_a=25 \pm 2^\circ C$ ,  $f_v=60Hz$  condition whereas mosaic pattern(8 x 6) is displayed and  $f_v$  is the frame frequency.

2. The current is specified at the maximum current pattern.

3. The duration of rush current is about 2ms and rising time of power input is 0.5ms (min.).

White : 1023 Gray

Black : 0 Gray

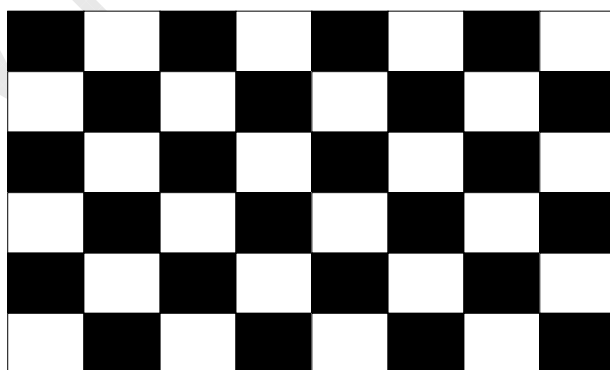
**Mosaic Pattern(8 x 6)**

LC420WUN

## Product Specification

Table 3. ELECTRICAL CHARACTERISTICS (Continue)

Parameter		Symbol	Values			Unit	Note	
			Min	Typ	Max			
<b>Inverter :</b>								
Power Supply Input Voltage		VBL	22.8	24.0	25.2	VDC	1	
Power Supply Input Current	After Aging	IBL_A	-	6.2	6.8	A	1	
	Before Aging	IBL_B	-	6.7	7.3	A	2	
Power Supply Input Current (In-Rush)		IRUSH	-	-	11	A	VBL = 22.8V EXTV <sub>BR-B</sub> = 100% 6	
Power Consumption (TBD)		PBL	-	149	164	W	1	
Input Voltage for Control System Signals	On/Off	On	VON	2.5	-	5.0	VDC	On Duty 7 5 5 High: Lamp on Low : Lamp off
		Off	VOFF	-0.3	0.0	0.8	VDC	
	Brightness Adjust		EXTV <sub>BR-B</sub>	30	-	100	%	
	PWM Frequency for NTSC & PAL		PAL		100		Hz	
			NTSC		120		Hz	
	Pulse Duty Level (PWM) (Burst mode)		High Level	2.5	-	5.0	VDC	
Low Level			0.0	-	0.8	VDC		
<b>Lamp:</b>								
Discharge Stabilization Time		Ts			3	min	3	
Life Time			50,000	60,000		Hrs	4	

- Note 1. Electrical characteristics are determined after the unit has been 'ON' and stable for approximately 120 minutes at  $25 \pm 2^\circ\text{C}$ . The specified current and power consumption are under the typical supply Input voltage 24V and  $V_{BR}$  (EXTV<sub>BR-B</sub>: 100%), it is total power consumption.
2. Electrical characteristics are determined within 30 minutes at  $25 \pm 2^\circ\text{C}$ . The specified currents are under the typical supply Input voltage 24V.
3. The brightness of the lamp after lighted for 5minutes is defined as 100%.  
TS is the time required for the brightness of the center of the lamp to be not less than 95% at typical current.  
The screen of LCD module may be partially dark by the time the brightness of lamp is stable after turn on.
4. Specified Values are for a single lamp which is aligned horizontally.  
The life time is determined as the time which luminance of the lamp is 50% compared to that of initial value at the typical lamp current (EXTV<sub>BR-B</sub>: 100%), on condition of continuous operating at  $25 \pm 2^\circ\text{C}$
5. LGD recommend that the PWM freq. is synchronized with Two times harmonic of Vsync signal of system.
6. The duration of rush current is about 10ms.
7. EXTV<sub>BR-B</sub> is based on input PWM duty of the inverter.

## Product Specification

**3-2. Interface Connections**

This LCD module employs two kinds of interface connection, 51-pin connector is used for the module electronics and 14-pin connector is used for the integral backlight system.

**3-2-1. LCD Module**

- LCD Connector : FI-R51S-HF(manufactured by JAE) or KN25-51P-0.5SH(manufactured by Hirose) (CN1) Refer to below table
- Mating Connector : FI-R51HL(JAE) or compatible

**Table 4. MODULE CONNECTOR(CN1) PIN CONFIGURATION**

No	Symbol	Description	No	Symbol	Description
1	NC	No Connection	27	Bit Select	'H' or NC= 10bit(D), 'L' = 8bit
2	NC	No Connection	28	R2AN	SECOND LVDS Receiver Signal (A-)
3	NC	No Connection	29	R2AP	SECOND LVDS Receiver Signal (A+)
4	NC	No Connection (Reserved for LGD)	30	R2BN	SECOND LVDS Receiver Signal (B-)
5	NC	No Connection (Reserved for LGD)	31	R2BP	SECOND LVDS Receiver Signal (B+)
6	NC	No Connection (Reserved for LGD)	32	R2CN	SECOND LVDS Receiver Signal (C-)
7	LVDS Select	'H' =JEIDA , 'L' or NC = VESA	33	R2CP	SECOND LVDS Receiver Signal (C+)
8	NC	No Connection	34	GND	Ground
9	NC	No Connection	35	R2CLKN	SECOND LVDS Receiver Clock Signal(-)
10	NC	No Connection	36	R2CLKP	SECOND LVDS Receiver Clock Signal(+)
11	GND	Ground	37	GND	Ground
12	R1AN	FIRST LVDS Receiver Signal (A-)	38	R2DN	SECOND LVDS Receiver Signal (D-)
13	R1AP	FIRST LVDS Receiver Signal (A+)	39	R2DP	SECOND LVDS Receiver Signal (D+)
14	R1BN	FIRST LVDS Receiver Signal (B-)	40	R2EN	SECOND LVDS Receiver Signal (E-)
15	R1BP	FIRST LVDS Receiver Signal (B+)	41	R2EP	SECOND LVDS Receiver Signal (E+)
16	R1CN	FIRST LVDS Receiver Signal (C-)	42	NC	No Connection
17	R1CP	FIRST LVDS Receiver Signal (C+)	43	NC	No Connection
18	GND	Ground	44	GND	Ground
19	R1CLKN	FIRST LVDS Receiver Clock Signal(-)	45	GND	Ground
20	R1CLKP	FIRST LVDS Receiver Clock Signal(+)	46	GND	Ground
21	GND	Ground	47	NC	No connection
22	R1DN	FIRST LVDS Receiver Signal (D-)	48	VLCD	Power Supply +12.0V
23	R1DP	FIRST LVDS Receiver Signal (D+)	49	VLCD	Power Supply +12.0V
24	R1EN	FIRST LVDS Receiver Signal (E-)	50	VLCD	Power Supply +12.0V
25	R1EP	FIRST LVDS Receiver Signal (E+)	51	VLCD	Power Supply +12.0V
26	NC	No Connection	-	-	-

- Note
1. All GND(ground) pins should be connected together to the LCD module's metal frame.
  2. All VLCD (power input) pins should be connected together.
  3. All Input levels of LVDS signals are based on the **EIA 644** Standard.
  4. Specific pins(pin No. **#2~#6**) are used for internal data process of the LCD module. These pins should be no connection.
  5. LVDS pin (pin No. **#24,25,40,41**) are used for 10Bit(D) of the LCD module. If used for 8Bit(R), these pins are no connection.
  6. Specific pin No. **#44** is used for "No signal detection" of system signal interface. It should be GND for NSB(No Signal Black) during the system interface signal is not. If this pin is "H", LCD Module displays AGP(Auto Generation Pattern).



LC420WUN

## Product Specification

## 3-2-2. Backlight Module

## [ Master ]

-Inverter Connector : 20022WR-14B1(Yeonho)  
or Equivalent

- Mating Connector : 20022HS-14 or Equivalent

Table 5. INVERTER CONNECTOR PIN CONFIGURATION

Pin No	Symbol	Description	Master	Note
1	VBL	Power Supply +24.0V	VBL	
2	VBL	Power Supply +24.0V	VBL	
3	VBL	Power Supply +24.0V	VBL	
4	VBL	Power Supply +24.0V	VBL	
5	VBL	Power Supply +24.0V	VBL	
6	GND	Backlight Ground	GND	
7	GND	Backlight Ground	GND	
8	GND	Backlight Ground	GND	1
9	GND	Backlight Ground	GND	
10	GND	Backlight Ground	GND	
11	NC	No Connection	NC	
12	VON/OFF	Backlight ON/OFF control	VON/OFF	3
13	EXTVBR-B	External PWM	EXTVBR-B	3
14	Status	Lamp Status	Status	2

Note 1. GND should be connected to the LCD module's metal frame.

2. Normal : Low (under 0.7V) / Abnormal : High (upper 3.0V)

Please see **Appendix IV-1** for more information.

3. The impedance of pin #12 is over 100[KΩ] & the impedance of Pin #13 is over 50[KΩ].

## ◆ Rear view of LCM

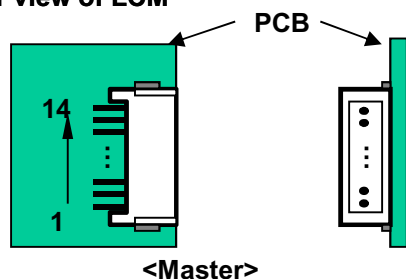

LC420WUN

## Product Specification

## 3-3. Signal Timing Specifications

Table 6 shows the signal timing required at the input of the LVDS transmitter. All of the interface signal timings should be satisfied with the following specification for normal operation.

Table 6-1. TIMING TABLE for NTSC (DE Only Mode)

ITEM		Symbol	Min	Typ	Max	Unit	Note
Horizontal	Display Period	t <sub>HV</sub>	-	960	-	tclk	
	Blank	t <sub>HB</sub>	100	140	240	tclk	
	Total	t <sub>HP</sub>	1060	1100	1200	tclk	2200/2
Vertical	Display Period	t <sub>VV</sub>	-	1080	-	tHP	
	Blank	t <sub>VB</sub>	11	45	69	tHP	
	Total	t <sub>VP</sub>	1091	1125	1149	tHP	
Frequency	DCLK	f <sub>CLK</sub>	70	74.25	77	MHz	148.5/2
	Horizontal	f <sub>H</sub>	65	67.5	70	KHz	
	Vertical	f <sub>V</sub>	57	60	63	Hz	

Table 6-2. TIMING TABLE for PAL (DE Only Mode)

ITEM		Symbol	Min	Typ	Max	Unit	Note
Horizontal	Display Period	t <sub>HV</sub>	-	960	-	tclk	
	Blank	t <sub>HB</sub>	100	140	240	tclk	
	Total	t <sub>HP</sub>	1060	1100	1200	tclk	2200/2
Vertical	Display Period	t <sub>VV</sub>	-	1080	-	tHP	
	Blank	t <sub>VB</sub>	228	270	300	tHP	
	Total	t <sub>VP</sub>	1308	1350	1380	tHP	
Frequency	DCLK	f <sub>CLK</sub>	70	74.25	77	MHz	148.5/2
	Horizontal	f <sub>H</sub>	65	67.5	70	KHz	
	Vertical	f <sub>V</sub>	47	50	53	Hz	

Note The Input of HSYNC & VSYNC signal does not have an effect on normal operation(DE Only Mode). The performance of the electro-optical characteristics may be influenced by variance of the vertical refresh rate.

## Product Specification

## 3-4. LVDS Signal Specification

## 3-4-1. LVDS Input Signal Timing Diagram

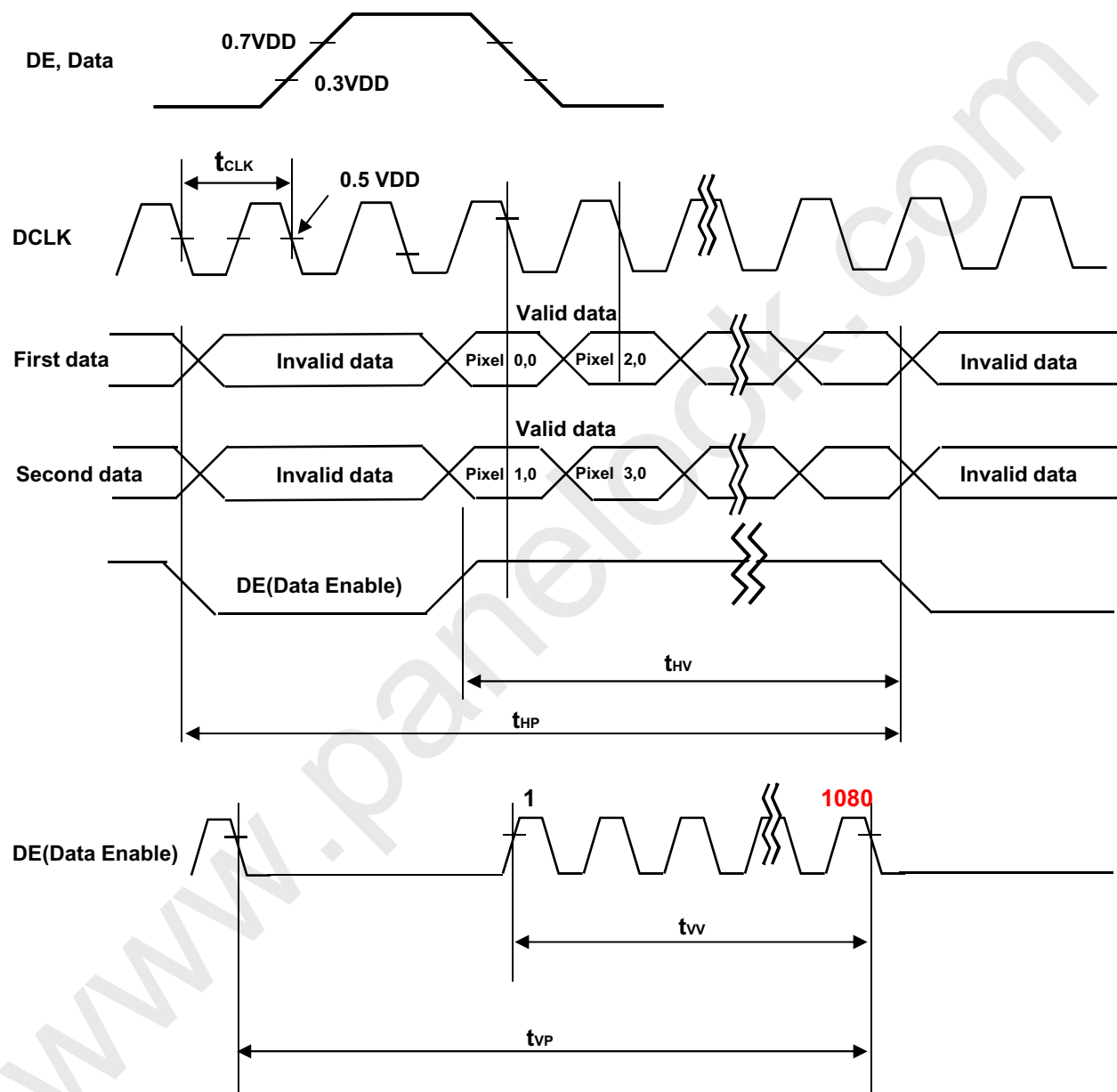

Product Specification

3-4-2. LVDS Input Signal Characteristics

1) DC Specification

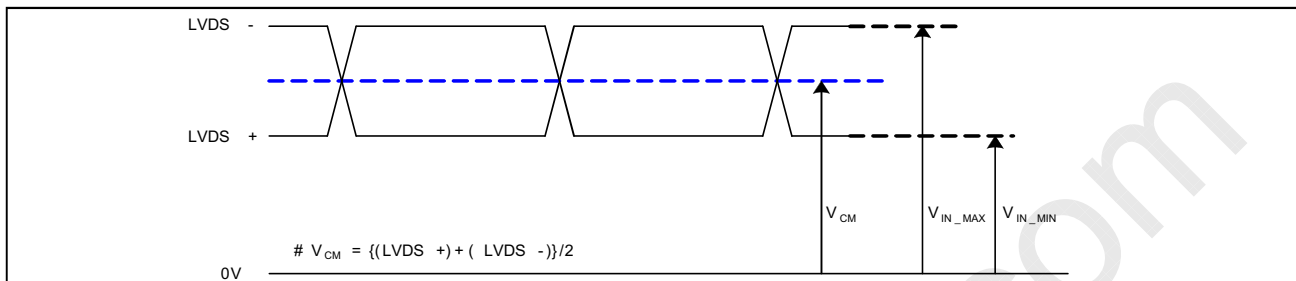

Description	Symbol	Min	Max	Unit	Note
LVDS Common mode Voltage	$V_{CM}$	1.0	1.5	V	-
LVDS Input Voltage Range	$V_{IN}$	0.7	1.8	V	-
Change in common mode Voltage	$\Delta V_{CM}$		250	mV	-

2) AC Specification

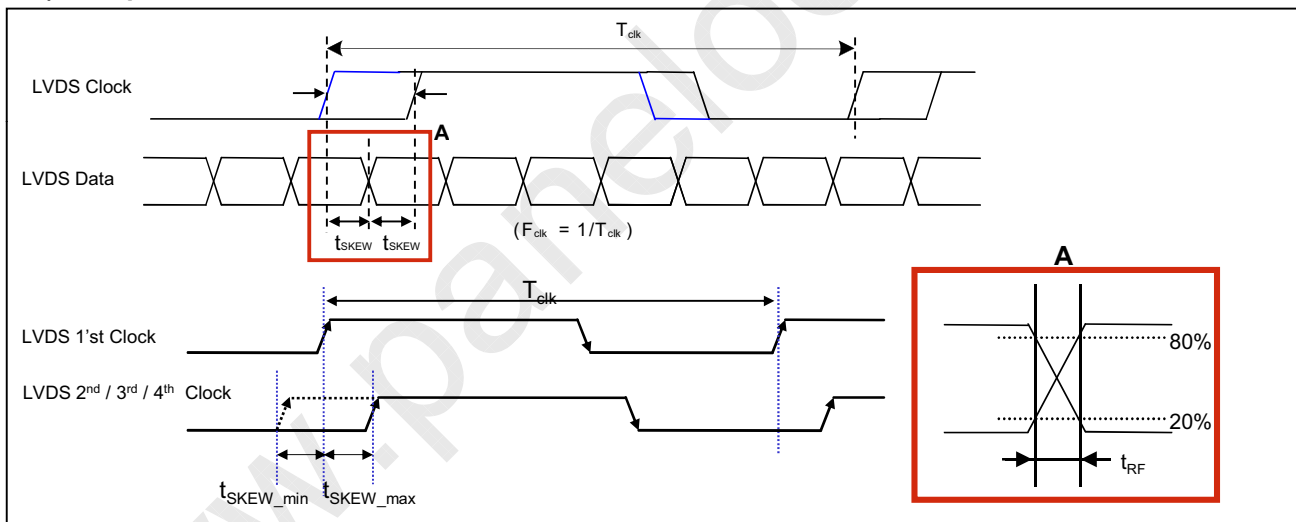

Description	Symbol	Min	Max	Unit	Note	
LVDS Differential Voltage	High Threshold	$V_{TH}$	100	300	mV	3
	Low Threshold	$V_{TL}$	-300	-100	mV	
LVDS Clock to Data Skew Margin	$t_{SKEW}$		$ (0.25 * T_{clk}) / 7 $	ps	-	
LVDS Clock/DATA Rising/Falling time	$t_{RF}$	260	$(0.3 * T_{clk}) / 7$	ps	2	
Effective time of LVDS	$t_{eff}$	$\pm 360$		ps	-	
LVDS Clock to Clock Skew Margin (Even to Odd)	$t_{SKEW\_EO}$		$1/7 * T_{clk}$	$T_{clk}$	-	

- Note
1. All Input levels of LVDS signals are based on the EIA 644 Standard.
  2. If  $t_{RF}$  isn't enough,  $t_{eff}$  should be meet the range.
  3. LVDS Differential Voltage is defined within  $t_{eff}$

LC420WUN

Product Specification

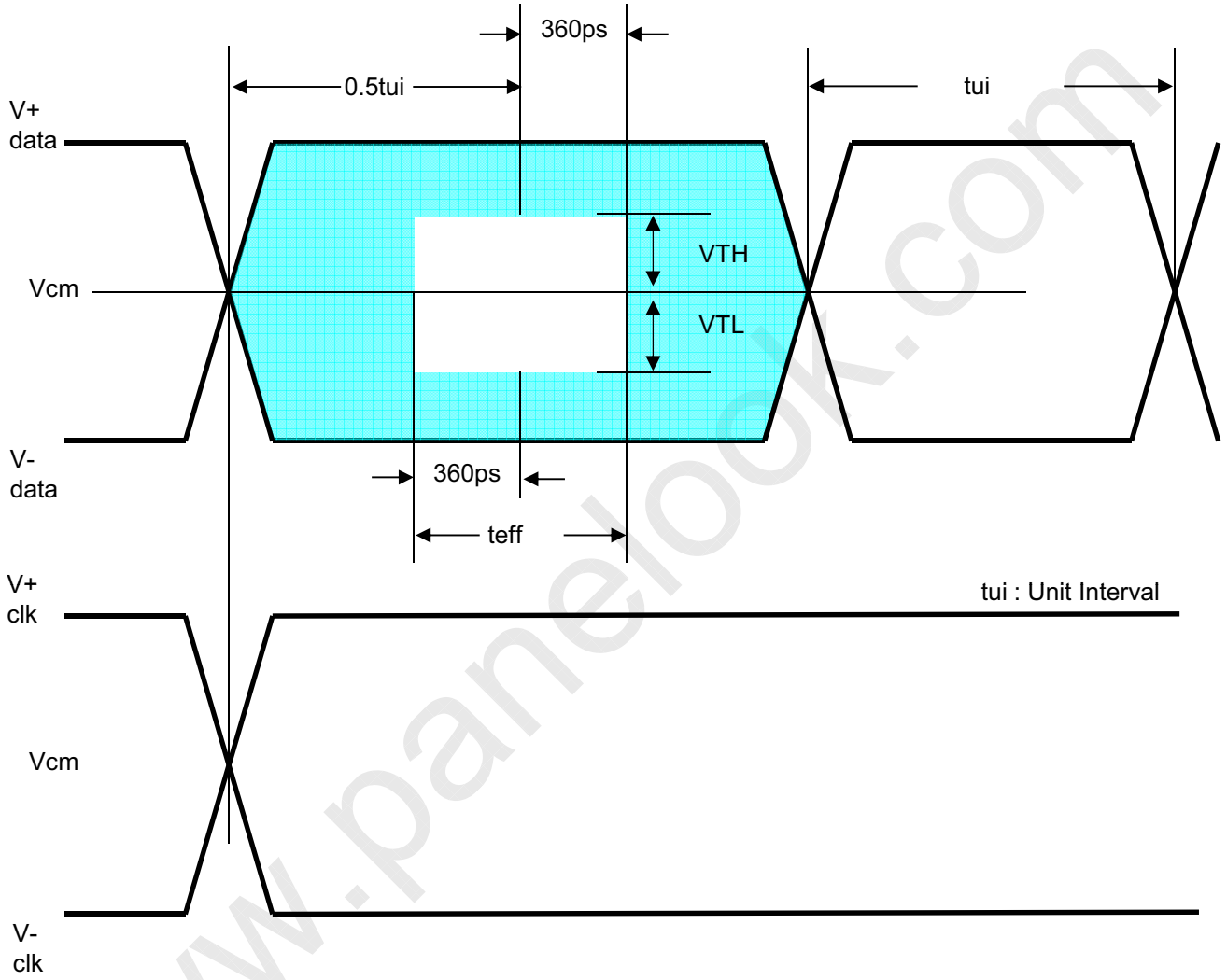

LC420WUN

## Product Specification

## 3-5. Color Data Reference

The brightness of each primary color(red,green,blue) is based on the 10bit gray scale data input for the color. The higher binary input, the brighter the color. Table 7 provides a reference for color versus data input.

Table 7. COLOR DATA REFERENCE

Color		Input Color Data																													
		RED										GREEN										BLUE									
		MSB									LSB	MSB									LSB	MSB									LSB
		R9	R8	R7	R6	R5	R4	R3	R2	R1	R0	G9	G8	G7	G6	G5	G4	G3	G2	G1	G0	B9	B8	B7	B6	B5	B4	B3	B2	B1	B0
Basic Color	Black	0	0	0	0	0	0	0	0	0	0	0	0	0	0	0	0	0	0	0	0	0	0	0	0	0	0	0	0	0	0
	Red (1023)	1	1	1	1	1	1	1	1	1	1	0	0	0	0	0	0	0	0	0	0	0	0	0	0	0	0	0	0	0	0
	Green (1023)	0	0	0	0	0	0	0	0	0	0	1	1	1	1	1	1	1	1	1	1	0	0	0	0	0	0	0	0	0	0
	Blue (1023)	0	0	0	0	0	0	0	0	0	0	0	0	0	0	0	0	0	0	0	0	1	1	1	1	1	1	1	1	1	1
	Cyan	0	0	0	0	0	0	0	0	0	0	1	1	1	1	1	1	1	1	1	1	1	1	1	1	1	1	1	1	1	1
	Magenta	1	1	1	1	1	1	1	1	1	1	0	0	0	0	0	0	0	0	0	0	1	1	1	1	1	1	1	1	1	1
	Yellow	1	1	1	1	1	1	1	1	1	1	1	1	1	1	1	1	1	1	1	1	0	0	0	0	0	0	0	0	0	0
	White	1	1	1	1	1	1	1	1	1	1	1	1	1	1	1	1	1	1	1	1	1	1	1	1	1	1	1	1	1	1
RED	RED (0000)	0	0	0	0	0	0	0	0	0	0	0	0	0	0	0	0	0	0	0	0	0	0	0	0	0	0	0	0	0	
	RED (0001)	0	0	0	0	0	0	0	0	0	0	0	0	0	0	0	0	0	0	0	0	0	0	0	0	0	0	0	0	0	
	...	...	...	...	...	...	...	...	...	...	...	...	...	...	...	...	...	...	...	...	...	...	...	...	...	...	...	...	...		
	RED (1022)	1	1	1	1	1	1	1	1	1	0	0	0	0	0	0	0	0	0	0	0	0	0	0	0	0	0	0	0	0	
	RED (1023)	1	1	1	1	1	1	1	1	1	0	0	0	0	0	0	0	0	0	0	0	0	0	0	0	0	0	0	0	0	
GREEN	GREEN (0000)	0	0	0	0	0	0	0	0	0	0	0	0	0	0	0	0	0	0	0	0	0	0	0	0	0	0	0	0	0	
	GREEN (0001)	0	0	0	0	0	0	0	0	0	0	0	0	0	0	0	0	0	0	0	0	0	0	0	0	0	0	0	0	0	
	...	...	...	...	...	...	...	...	...	...	...	...	...	...	...	...	...	...	...	...	...	...	...	...	...	...	...	...			
	GREEN (1022)	0	0	0	0	0	0	0	0	0	1	1	1	1	1	1	1	1	1	1	0	0	0	0	0	0	0	0	0	0	
	GREEN (1023)	0	0	0	0	0	0	0	0	0	1	1	1	1	1	1	1	1	1	1	0	0	0	0	0	0	0	0	0	0	
BLUE	BLUE (0000)	0	0	0	0	0	0	0	0	0	0	0	0	0	0	0	0	0	0	0	0	0	0	0	0	0	0	0	0	0	
	BLUE (0001)	0	0	0	0	0	0	0	0	0	0	0	0	0	0	0	0	0	0	0	0	0	0	0	0	0	0	0	0	1	
	...	...	...	...	...	...	...	...	...	...	...	...	...	...	...	...	...	...	...	...	...	...	...	...	...	...	...	...			
	BLUE (1022)	0	0	0	0	0	0	0	0	0	0	0	0	0	0	0	0	0	0	0	1	1	1	1	1	1	1	1	1	0	
	BLUE (1023)	0	0	0	0	0	0	0	0	0	0	0	0	0	0	0	0	0	0	0	1	1	1	1	1	1	1	1	1	1	

LC420WUN

## Product Specification

## 3-6. Power Sequence

## 3-6-1. LCD Driving circuit

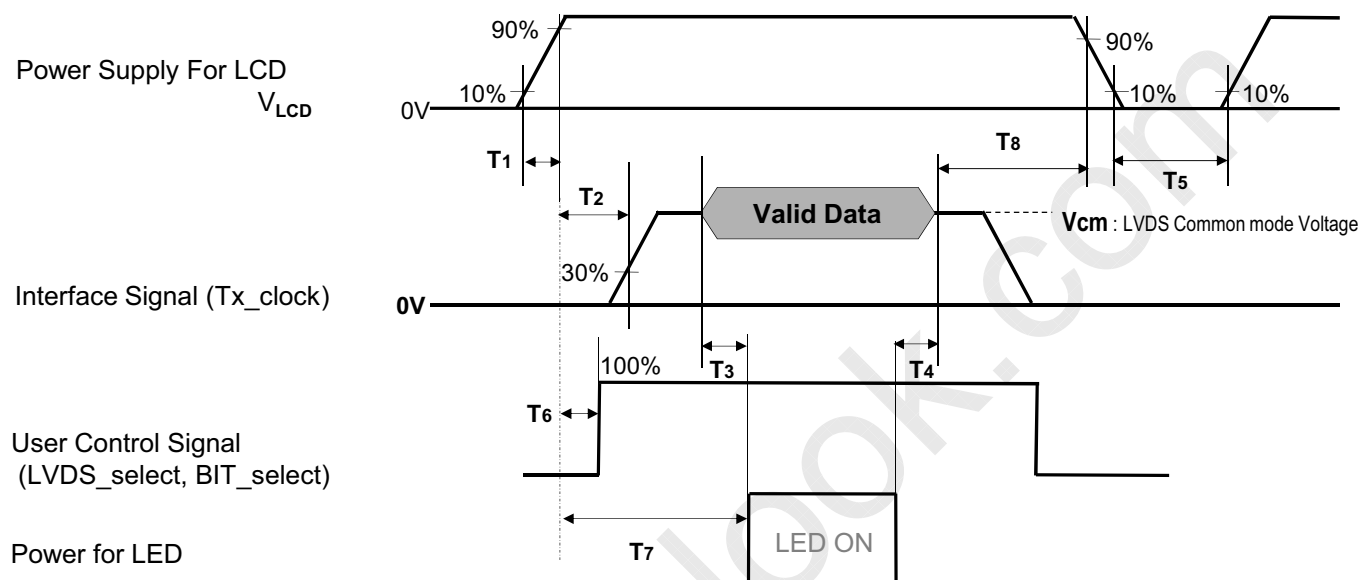

Table 8. POWER SEQUENCE

Parameter	Value			Unit	notes
	Min	Typ	Max		
T1	0.5	-	20	ms	1
T2	0	-	-	ms	2
T3	200	-	-	ms	3
T4	200	-	-	ms	3
T5	1.0	-	-	s	4
T6	-	-	T2	ms	5
T7	0.5	-	-	s	6
T8	100	-	-	ms	7

- notes :
1. Even though T1 is over the specified value, there is no problem if I2T spec of fuse is satisfied.
  2. If T2 is satisfied with specification after removing LVDS Cable, there is no problem.
  3. The T3 / T4 is recommended value, the case when failed to meet a minimum specification, abnormal display would be shown. There is no reliability problem.
  4. T5 should be measured after the Module has been fully discharged between power off and on period.
  5. If the on time of signals (Interface signal and user control signals) precedes the on time of Power ( $V_{LCD}$ ), it will be happened abnormal display. When T6 is NC status, T6 doesn't need to be measured.
  6. If there is no abnormal display, no problem.
  7. It is recommendation specification that T8 has to be 100ms as a minimum value.
- ※ Please avoid floating state of interface signal at invalid period.  
 ※ When the power supply for LCD ( $V_{LCD}$ ) is off, be sure to pull down the valid and invalid data to 0V.

## Product Specification

## 3-6-2. Sequence for Inverter

## Power Supply For Inverter

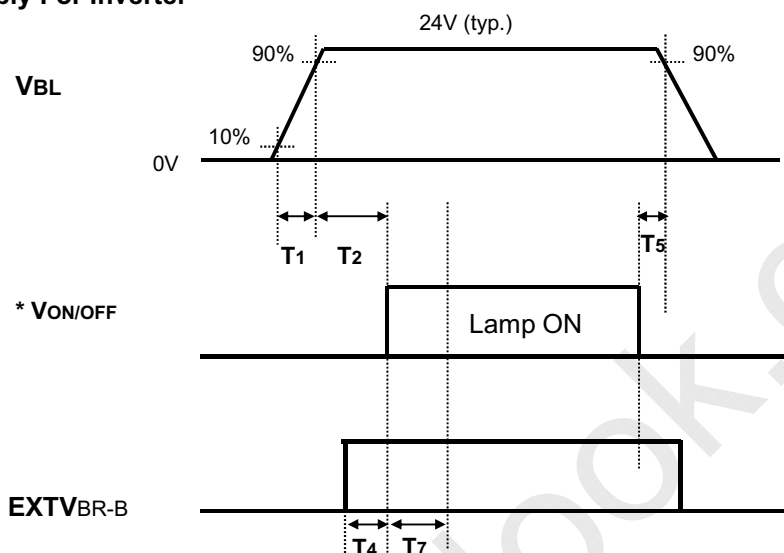

## 3-6-3. Dip condition for Inverter

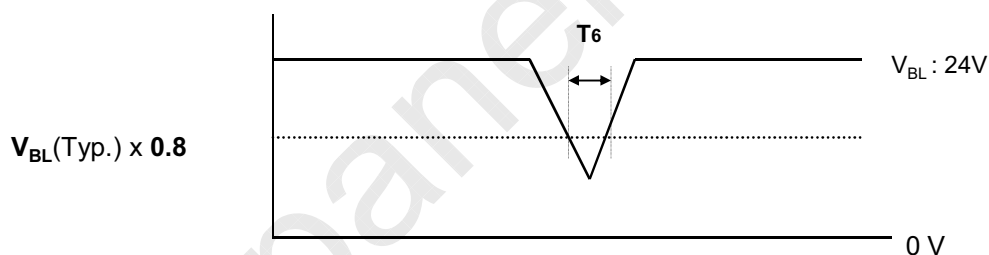

Table 9. Power Sequence for Inverter

Parameter	Values			Units	Note
	Min	Typ	Max		
T1	20	-	-	ms	1
T2	500	-	-	ms	
T4	0	-	-	ms	2
T5	10	-	-	ms	
T6	-	-	10	ms	$V_{BL}(Typ.) \times 0.8$
T7	1000	-	-	ms	3

Notes : 1. T1 describes rising time of 0V to 24V and this parameter does not applied at restarting time.

2. T4(max) is less than T2.

3. It is the recommendation to input Max Duty to Inverter\*\* for EXT VBR-B during T7 period.

\*\*When OPC Function is applied, the Max Duty is input to T-Con.

\* The recommendation of VON/OFF rising time is under 10ms.



LC420WUN

## Product Specification

## 4. Optical Specification

Optical characteristics are determined after the unit has been 'ON' and stable in a dark environment at  $25\pm 2^{\circ}\text{C}$ . The values are specified at an approximate distance 50cm from the LCD surface at a viewing angle of  $\Phi$  and  $\theta$  equal to  $0^{\circ}$ .

It is presented additional information concerning the measurement equipment and method in FIG. 1.

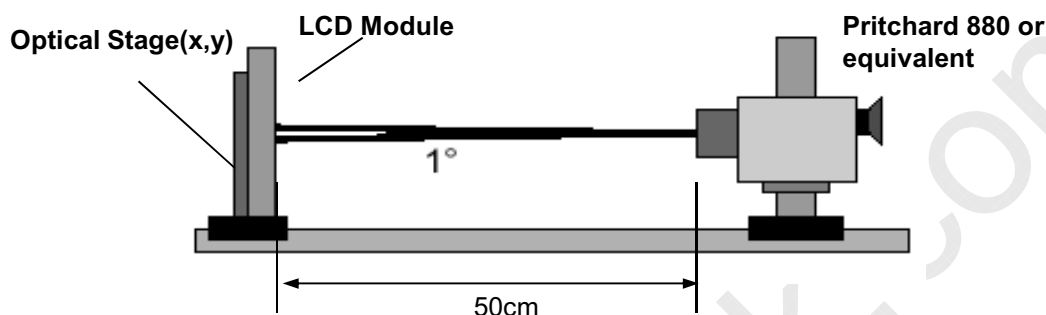

FIG. 1 Optical Characteristic Measurement Equipment and Method

$T_a = 25\pm 2^{\circ}\text{C}$ ,  $V_{\text{LCD}} = 12.0\text{V}$ ,  $f_v = 60\text{Hz}$ ,  $D_{\text{clk}} = 74.25\text{MHz}$ ,  
 $\text{EXTV}_{\text{BR-B}} = 100\%$

Table 10. OPTICAL CHARACTERISTICS

Parameter	Symbol	Value			Unit	Note	
		Min	Typ	Max			
Contrast Ratio	CR	1100	1500	-		1	
Surface Luminance, white	$L_{\text{WH}}$	320	400	-	cd/m <sup>2</sup>	2	
Luminance Variation	$\delta_{\text{WHITE}}$   5P	-	-	1.3		3	
Response Time	Gray-to-Gray	G to G	-	5	8	ms	4
	Uniformity	$\delta_{\text{G TO G}}$	-	-	1	ms	5
Color Coordinates [CIE1931]	RED	Rx		0.636			
		Ry		0.335			
	GREEN	Gx		0.291			
		Gy	Typ	0.603	Typ	+0.07	
	BLUE	Bx	-0.07	0.146			
		By		0.061			
	WHITE	Wx		0.279			
Wy			0.292				
Color Temperature			10,000		K		
Color Gamut			72		%		
Viewing Angle (CR>10)							
	x axis, right ( $\phi=0^{\circ}$ )	$\theta_r$	89	-	-	degree	6
	x axis, left ( $\phi=180^{\circ}$ )	$\theta_l$	89	-	-		
	y axis, up ( $\phi=90^{\circ}$ )	$\theta_u$	89	-	-		
	y axis, down ( $\phi=270^{\circ}$ )	$\theta_d$	89	-	-		
Gray Scale			-	-	-		7

## Product Specification

Note : 1. Contrast Ratio(CR) is defined mathematically as :

$$\text{Contrast Ratio} = \frac{\text{Surface Luminance with all white pixels}}{\text{Surface Luminance with all black pixels}}$$

It is measured at center 1-point.

2. Surface luminance are determined after the unit has been 'ON' and 1 Hour after lighting the backlight in a dark environment at  $25 \pm 2^\circ\text{C}$ . Surface luminance is the luminance value at center 1-point across the LCD surface 50cm from the surface with all pixels displaying white. For more information see the FIG. 2.

3. The variation in surface luminance,  $\delta$  WHITE is defined as :

$$\delta \text{ WHITE}(5P) = \text{Maximum}(L_{on1}, L_{on2}, L_{on3}, L_{on4}, L_{on5}) / \text{Minimum}(L_{on1}, L_{on2}, L_{on3}, L_{on4}, L_{on5})$$

Where  $L_{on1}$  to  $L_{on5}$  are the luminance with all pixels displaying white at 5 locations .

For more information, see the FIG. 2.

4. Response time is the time required for the display to transit from G(N) to G(M) (Rise Time,  $Tr_R$ ) and from G(M) to G(N) (Decay Time,  $Tr_D$ ). For additional information see the FIG. 3. (N<M)

※ G to G Spec stands for average value of all measured points.

Photo Detector : RD-80S / Field :  $2^\circ$

5. Gray to Gray Response time uniformity is Reference data. Please see **Appendix V**.

6. Viewing angle is the angle at which the contrast ratio is greater than 10. The angles are determined for the horizontal or x axis and the vertical or y axis with respect to the z axis which is normal to the LCD module surface. For more information, see the FIG. 4.

7. Gray scale specification

Gamma Value is approximately 2.2. For more information, see the Table 11.

**Table 11. GRAY SCALE SPECIFICATION**

Gray Level	Luminance [%] (Typ)
L0	0.07
L15	0.27
L31	1.04
L47	2.49
L63	4.68
L79	7.66
L95	11.5
L111	16.1
L127	21.6
L143	28.1
L159	35.4
L175	43.7
L191	53.0
L207	63.2
L223	74.5
L239	86.7
L255	100

LC420WUN

## Product Specification

Measuring point for surface luminance &amp; luminance variation

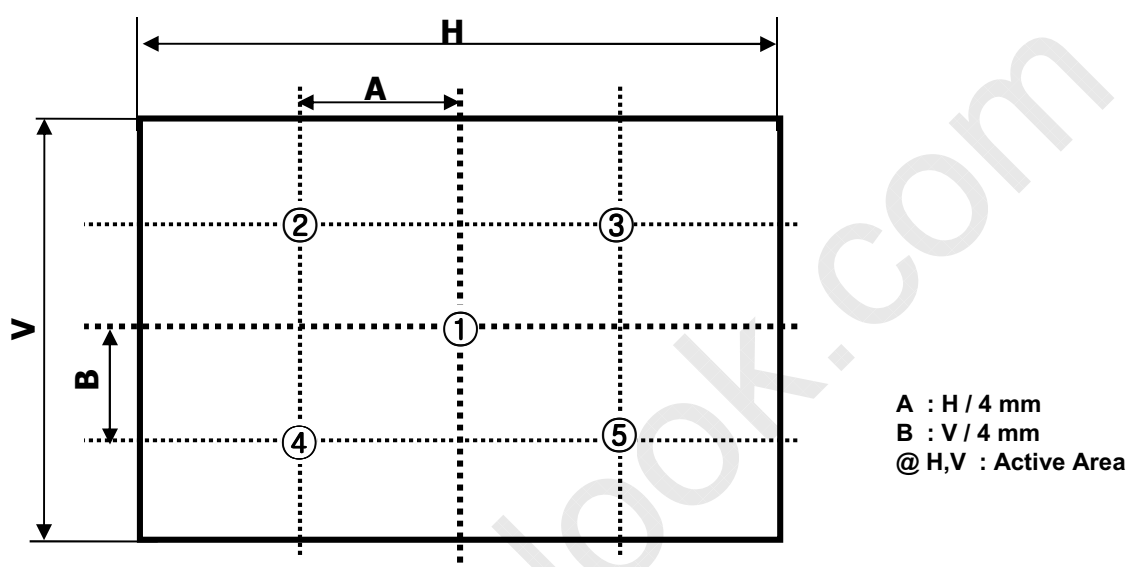

FIG. 2 5 Points for Luminance Measure

Response time is defined as the following figure and shall be measured by switching the input signal for "Gray(N)" and "Gray(M)".

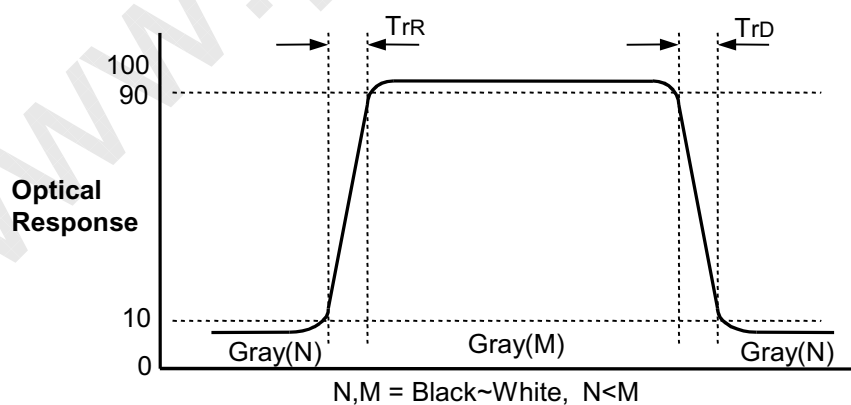

FIG. 3 Response Time

Product Specification

Dimension of viewing angle range

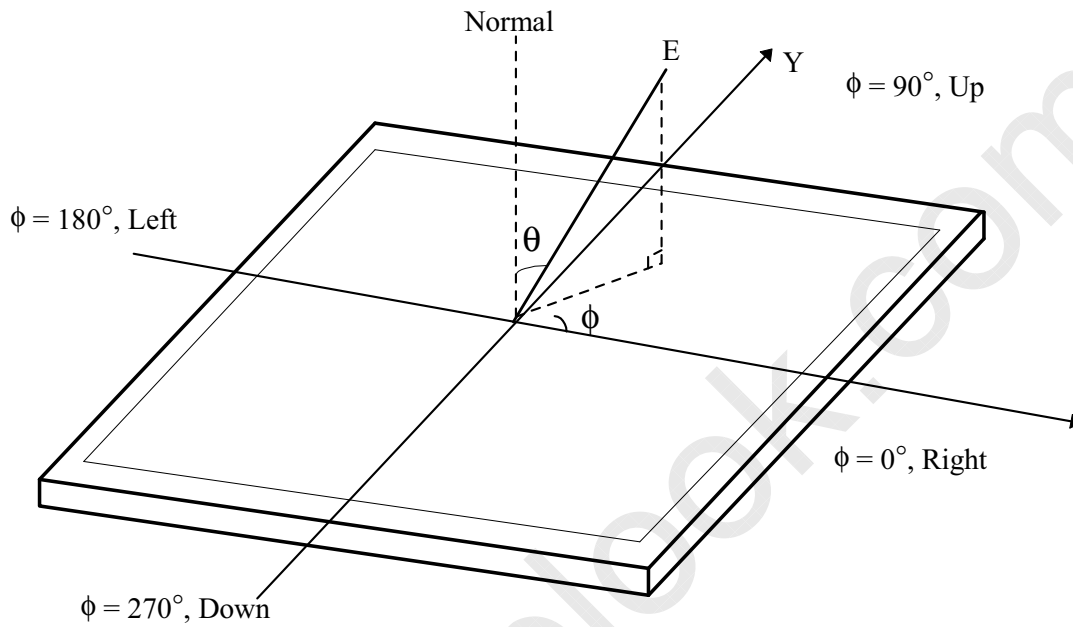

FIG. 4 Viewing Angle

LC420WUN

## Product Specification

**5. Mechanical Characteristics**

Table 12 provides general mechanical characteristics.

**Table 12. MECHANICAL CHARACTERISTICS**

Item	Value	
Outline Dimension	Horizontal	983.0 mm
	Vertical	576.0 mm
	Depth	51.0mm
Bezel Area	Horizontal	939.0 mm
	Vertical	531.0 mm
Active Display Area	Horizontal	930.24 mm
	Vertical	523.26 mm
Weight	9.1 Kg (Typ.) , 10.0 Kg (MAX)	

Note : Please refer to a mechanical drawing in terms of tolerance at the next page.

LC420WUN

Product Specification

[ FRONT VIEW ]

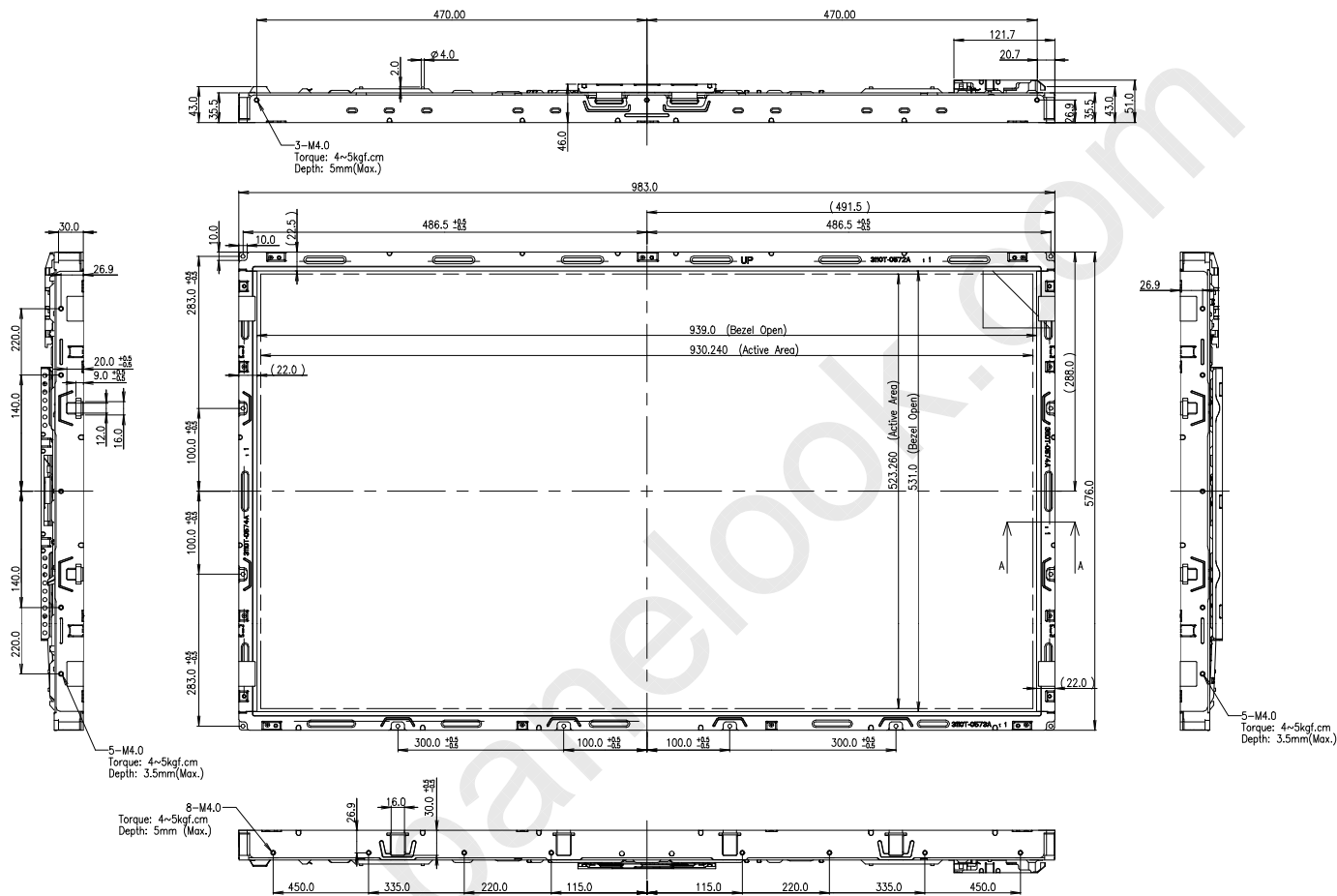

NOTES

1. Unspecified tolerances are to be  $\pm 1.0\text{mm}$ .
2. Tilt and partial disposition tolerance of display area is as following.
  - (1) X-Direction :  $IA-BI \leq 1.5\text{mm}$
  - (2) Y-Direction :  $IC-DI \leq 1.5\text{mm}$

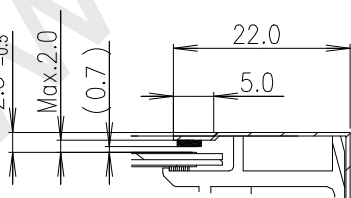

SECTION A-A  
SCALE 1/1

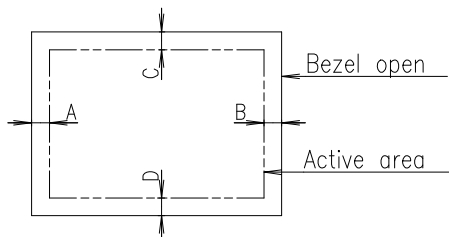

LC420WUN

Product Specification

[ REAR VIEW ]

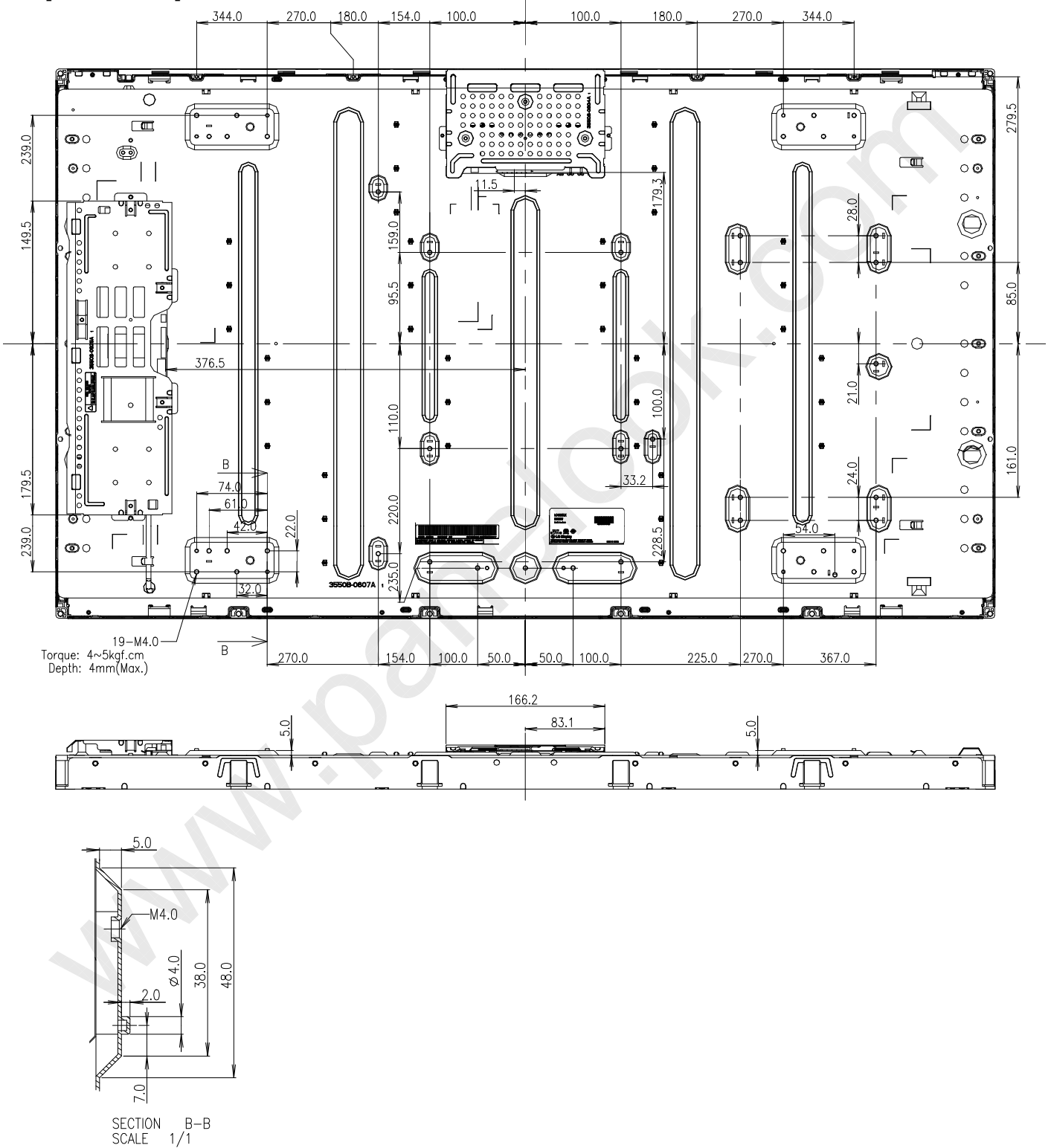

SECTION B-B  
SCALE 1/1

LC420WUN

## Product Specification

## 6. Reliability

Table 13. ENVIRONMENT TEST CONDITION

No.	Test Item	Condition
1	High temperature storage test	Ta= 60°C 240h
2	Low temperature storage test	Ta= -20°C 240h
3	High temperature operation test	Ta= 50°C 50%RH 240h
4	Low temperature operation test	Ta= 0°C 240h
5	Vibration test (non-operating)	Wave form : random Vibration level : 1.0Grms Bandwidth : 10-300Hz Duration : X,Y,Z, 30 min Each direction per 10 min
6	Shock test (non-operating)	Shock level : 50Grms Waveform : half sine wave, 11ms Direction : ±X, ±Y, ±Z One time each direction
7	Humidity condition Operation	Ta= 40 °C ,90%RH
8	Altitude operating storage / shipment	0 - 15,000 ft 0 - 40,000 ft

Note : Before and after Reliability test, LCM should be operated with normal function.



## Product Specification

## 7. International Standards

### 7-1. Safety

- a) UL 60065, Seventh Edition, Underwriters Laboratories Inc.  
Audio, Video and Similar Electronic Apparatus - Safety Requirements.
- b) CAN/CSA C22.2 No.60065:03, Canadian Standards Association.  
Audio, Video and Similar Electronic Apparatus - Safety Requirements.
- c) EN 60065:2002 + A11:2008, European Committee for Electrotechnical Standardization (CENELEC).  
Audio, Video and Similar Electronic Apparatus - Safety Requirements.
- d) IEC 60065:2005 + A1:2005, The International Electrotechnical Commission (IEC).  
Audio, Video and Similar Electronic Apparatus - Safety Requirements.

### 7-2. EMC

- a) ANSI C63.4 "American National Standard for Methods of Measurement of Radio-Noise Emissions from Low-Voltage Electrical and Electronic Equipment in the Range of 9 kHz to 40 GHz." American National Standards Institute (ANSI), 2003.
- b) CISPR 22 "Information technology equipment – Radio disturbance characteristics – Limit and methods of measurement." International Special Committee on Radio Interference (CISPR), 2005.
- c) CISPR 13 "Sound and television broadcast receivers and associated equipment – Radio disturbance characteristics – Limits and method of measurement." International Special Committee on Radio Interference (CISPR), 2006.

### 7-3. Environment

- a) RoHS, Directive 2002/95/EC of the European Parliament and of the council of 27 January 2003

LC420WUN

## Product Specification

**8. Packing****8-1. Information of LCM Label**

a) Lot Mark

A	B	C	D	E	F	G	H	I	J	K	L	M
---	---	---	---	---	---	---	---	---	---	---	---	---

A,B,C : SIZE(INCH)  
E : MONTH

D : YEAR  
F ~ M : SERIAL NO.

notes

## 1. YEAR

Year	2011	2012	2013	2014	2015	2016	2017	2018	2019	2020
Mark	A	B	C	D	E	F	G	H	J	K

## 2. MONTH

Month	Jan	Feb	Mar	Apr	May	Jun	Jul	Aug	Sep	Oct	Nov	Dec
Mark	1	2	3	4	5	6	7	8	9	A	B	C

b) Location of Lot Mark

Serial NO. is printed on the label. The label is attached to the backside of the LCD module.  
This is subject to change without prior notice.

**8-2. Packing Form**

a) Package quantity in one Pallet : 12 pcs

b) Pallet Size : 1150 mm X 1020 mm X 815 mm.

## Product Specification

## 9. Precautions

Please pay attention to the followings when you use this TFT LCD module.

### 9-1. Mounting Precautions

- (1) You must mount a module using specified mounting holes (Details refer to the drawings).
- (2) You should consider the mounting structure so that uneven force (ex. Twisted stress) is not applied to the module. And the case on which a module is mounted should have sufficient strength so that external force is not transmitted directly to the module.
- (3) Please attach the surface transparent protective plate to the surface in order to protect the polarizer. Transparent protective plate should have sufficient strength in order to resist external force.
- (4) You should adopt radiation structure to satisfy the temperature specification.
- (5) Acetic acid type and chlorine type materials for the cover case are not desirable because the former generates corrosive gas of attacking the polarizer at high temperature and the latter causes circuit break by electro-chemical reaction.
- (6) Do not touch, push or rub the exposed polarizers with glass, tweezers or anything harder than HB pencil lead. And please do not rub with dust clothes with chemical treatment. Do not touch the surface of polarizer for bare hand or greasy cloth.(Some cosmetics are detrimental to the polarizer.)
- (7) When the surface becomes dusty, please wipe gently with absorbent cotton or other soft materials like chamois soaks with petroleum benzine. Normal-hexane is recommended for cleaning the adhesives used to attach front / rear polarizers. Do not use acetone, toluene and alcohol because they cause chemical damage to the polarizer.
- (8) Wipe off saliva or water drops as soon as possible. Their long time contact with polarizer causes deformations and color fading.
- (9) Do not open the case because inside circuits do not have sufficient strength.

### 9-2. Operating Precautions

- (1) The spike noise causes the mis-operation of circuits. It should be lower than following voltage :  
 $V = \pm 200\text{mV}$  (Over and under shoot voltage)
- (2) Response time depends on the temperature. (In lower temperature, it becomes longer.)
- (3) Brightness depends on the temperature. (In lower temperature, it becomes lower.)  
And in lower temperature, response time (required time that brightness is stable after turned on) becomes longer
- (4) Be careful for condensation at sudden temperature change. Condensation makes damage to polarizer or electrical contacted parts. And after fading condensation, smear or spot will occur.
- (5) When fixed patterns are displayed for a long time, remnant image is likely to occur.
- (6) Module has high frequency circuits. Sufficient suppression to the electromagnetic interference shall be done by system manufacturers. Grounding and shielding methods may be important to minimized the interference.
- (7) Please do not give any mechanical and/or acoustical impact to LCM. Otherwise, LCM can't be operated its full characteristics perfectly.
- (8) A screw which is fastened up the steels should be a machine screw.  
(if not, it can causes conductive particles and deal LCM a fatal blow)
- (9) Please do not set LCD on its edge.
- (10) The conductive material and signal cables are kept away from transformers to prevent abnormal display, sound noise and temperature rising.
- (11) Partial darkness may happen during 3~5 minutes when LCM is operated initially in condition that luminance is under 40% at low temperature (under 5°C). This phenomenon which disappears naturally after 3~5 minutes is not a problem about reliability but LCD characteristic.

## Product Specification

- (12) Partial darkness may happen under the long-term operation of any dimming without power on/off. This phenomenon which disappears naturally after 5 minutes is not a problem about reliability but LCD characteristics.

### 9-3. Electrostatic Discharge Control

Since a module is composed of electronic circuits, it is not strong to electrostatic discharge. Make certain that treatment persons are connected to ground through wrist band etc. And don't touch interface pin directly.

### 9-4. Precautions for Strong Light Exposure

Strong light exposure causes degradation of polarizer and color filter.

### 9-5. Storage

When storing modules as spares for a long time, the following precautions are necessary.

- (1) Store them in a dark place. Do not expose the module to sunlight or fluorescent light. Keep the temperature between 5°C and 35°C at normal humidity.
- (2) The polarizer surface should not come in contact with any other object.  
It is recommended that they be stored in the container in which they were shipped.

### 9-6. Handling Precautions for Protection Film

- (1) The protection film is attached to the bezel with a small masking tape.  
When the protection film is peeled off, static electricity is generated between the film and polarizer. This should be peeled off slowly and carefully by people who are electrically grounded and with well ion-blown equipment or in such a condition, etc.
- (2) When the module with protection film attached is stored for a long time, sometimes there remains a very small amount of glue still on the bezel after the protection film is peeled off.
- (3) You can remove the glue easily. When the glue remains on the bezel surface or its vestige is recognized, please wipe them off with absorbent cotton waste or other soft material like chamois soaked with normal-hexane.

LC420WUN

## Product Specification

## # APPENDIX-I

## ■ Pallet Ass'y

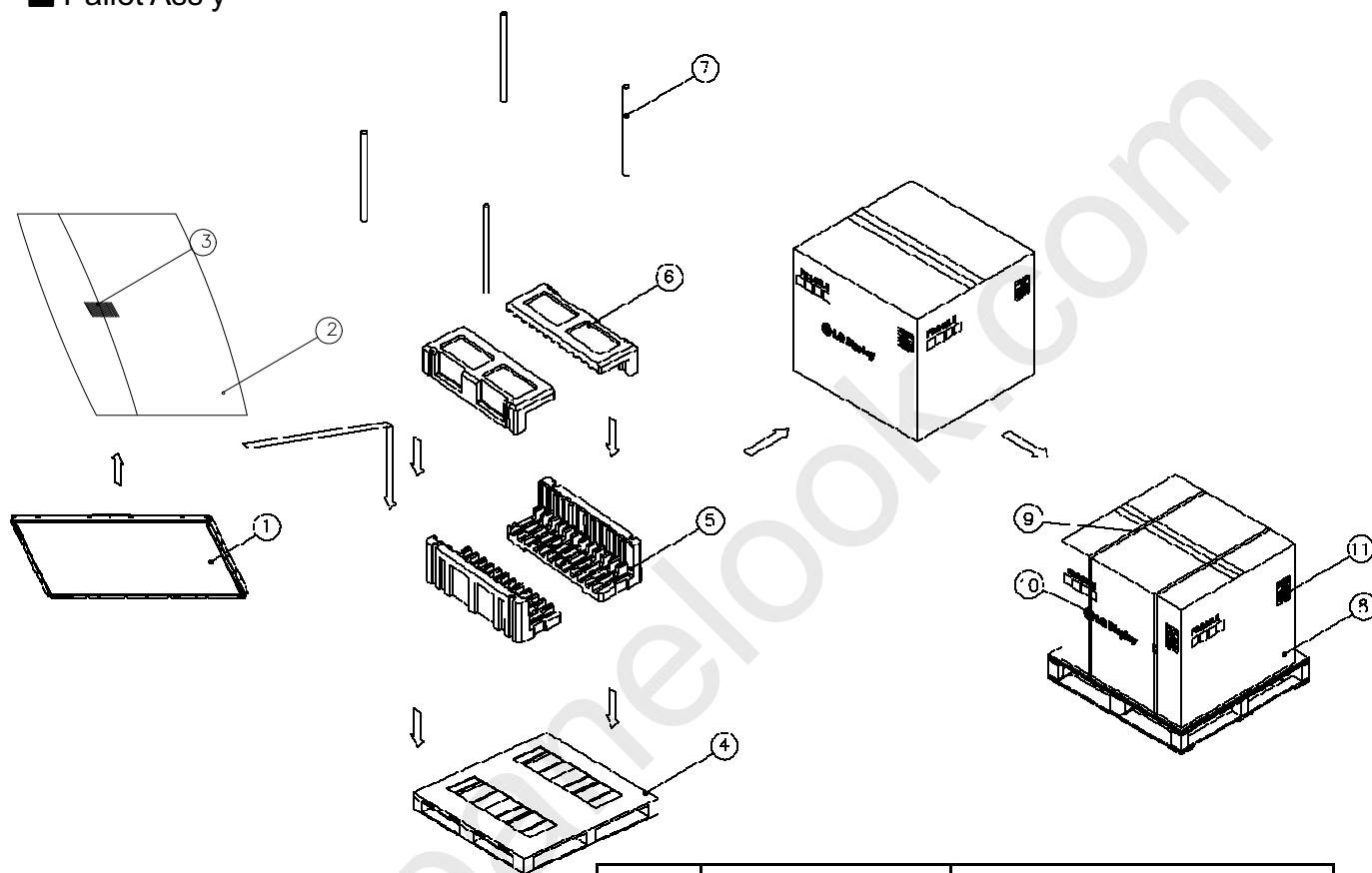

NO.	DESCRIPTION	MATERIAL
1	LCD Module	
2	BAG	42INCH
3	TAPE	MASKING 20MM X 50M
4	PALLET	Plywood (1140X990X125.5)
5	PACKING	EPS
6	PACKING	EPS
7	ANGLE PACKING	PAPER
8	ANGLE COVER	PAPER
9	BAND,CLIP	STEEL
10	BAND	PP
11	LABEL	YUPO PAPER 80G 100X100

LC420WUN

## # APPENDIX- II-1

## ■ LCM Label



LC420WUN

## # APPENDIX- II-2

## ■ Pallet Label

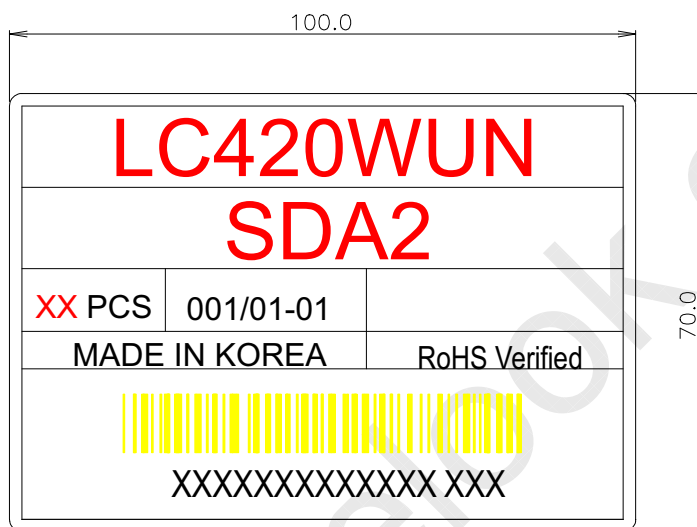

LC420WUN

## Product Specification

## # APPENDIX- III-1

■ Required signal assignment for Flat Link (Thine : THC63LVD103) Transmitter(Pin7="L")

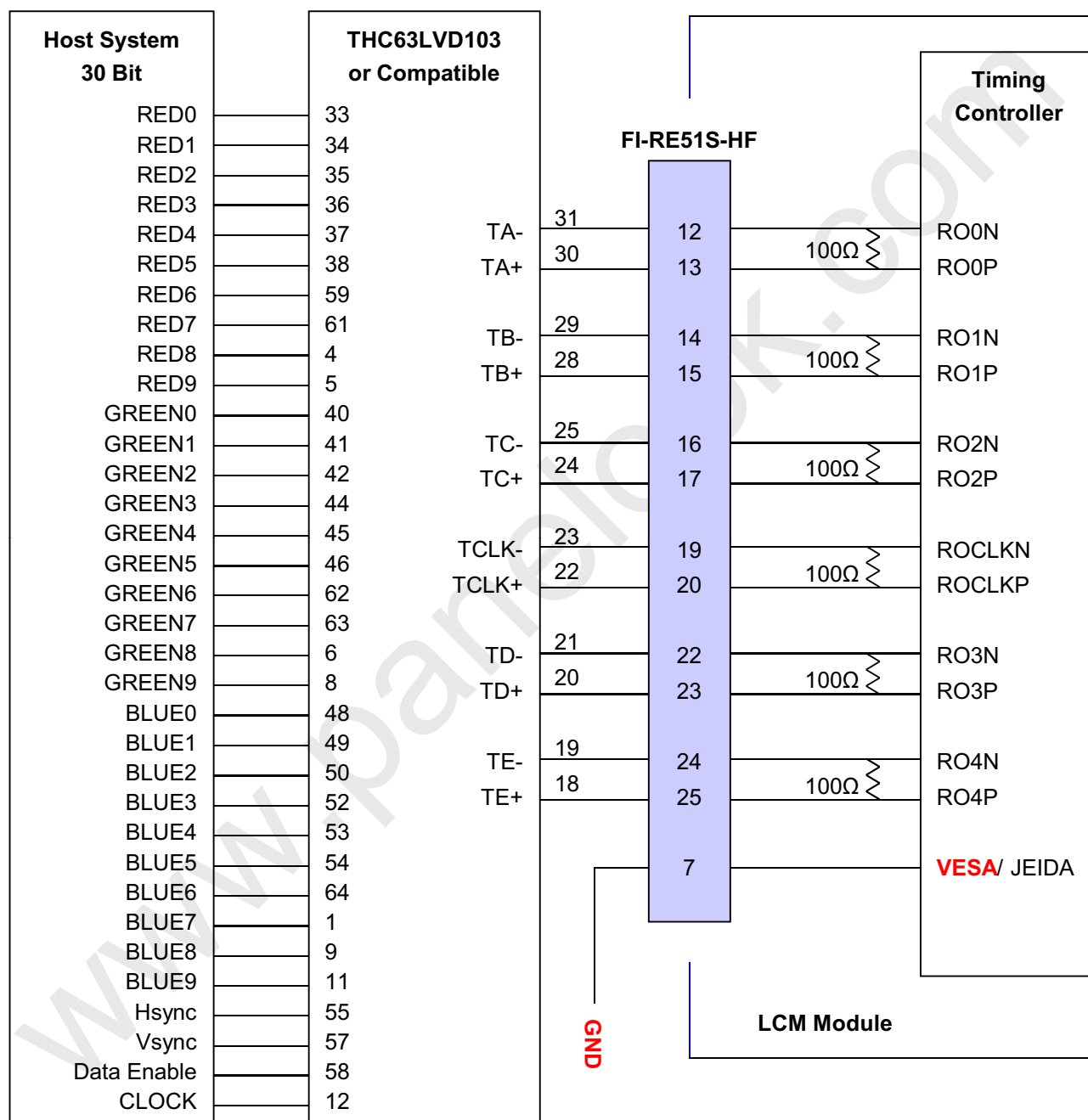

Note: 1. The LCD module uses a 100 Ohm[Ω] resistor between positive and negative lines of each receiver input.

2. Refer to LVDS Transmitter Data Sheet for detail descriptions. (THC63LVD103 or Compatible)

3. '9' means MSB and '0' means LSB at R,G,B pixel data.



LC420WUN

## Product Specification

## # APPENDIX- III-1

■ Required signal assignment for Flat Link (Thine : THC63LVD103) Transmitter(Pin7="H")

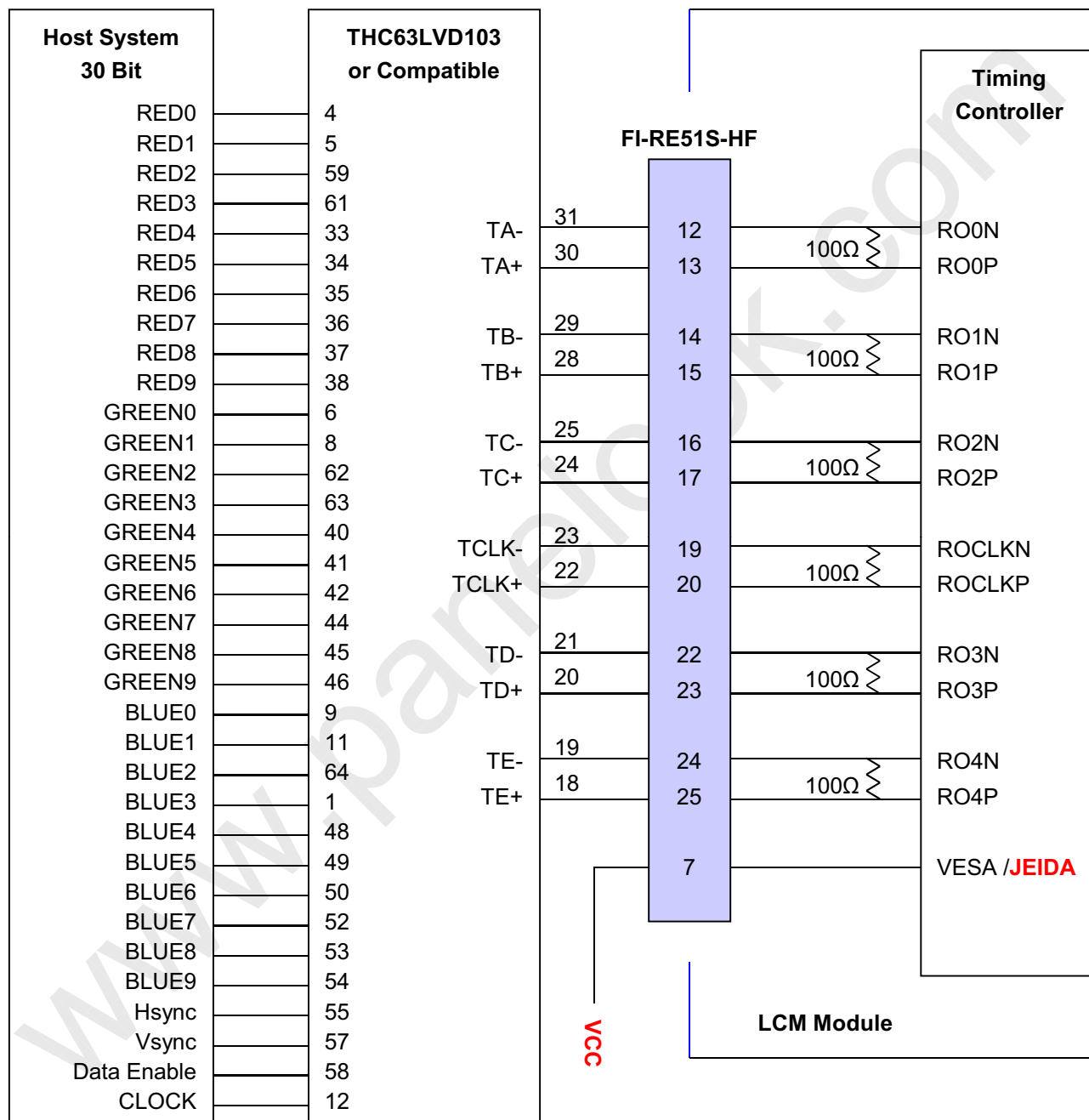

Note :1. The LCD module uses a 100 Ohm[Ω] resistor between positive and negative lines of each receiver input.

2. Refer to LVDS Transmitter Data Sheet for detail descriptions. (THC63LVD103 or Compatible)

3. '9' means MSB and '0' means LSB at R,G,B pixel data.

## Product Specification

## # APPENDIX- III-2

## ■ LVDS Data-Mapping Information (10 Bit )

## 1) LVDS Select : "H" Data-Mapping (JEIDA format)

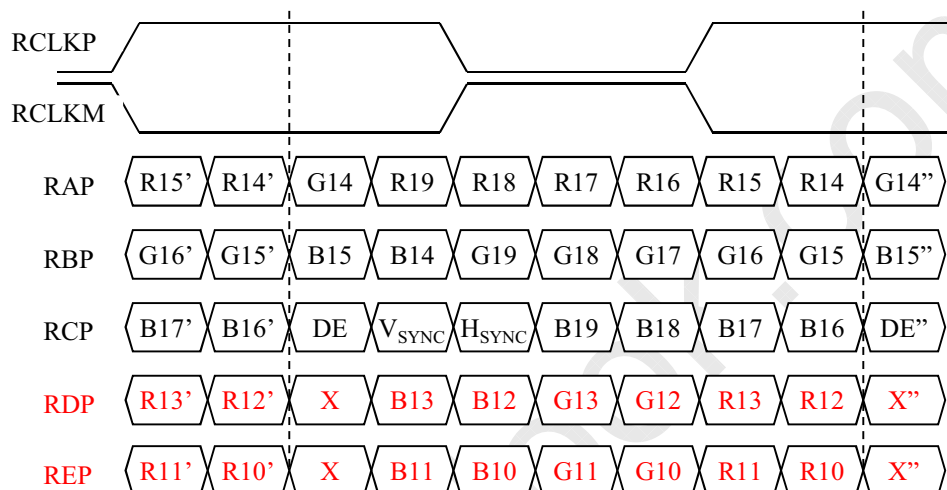

## 2) LVDS Select : "L" Data-Mapping (VESA format)

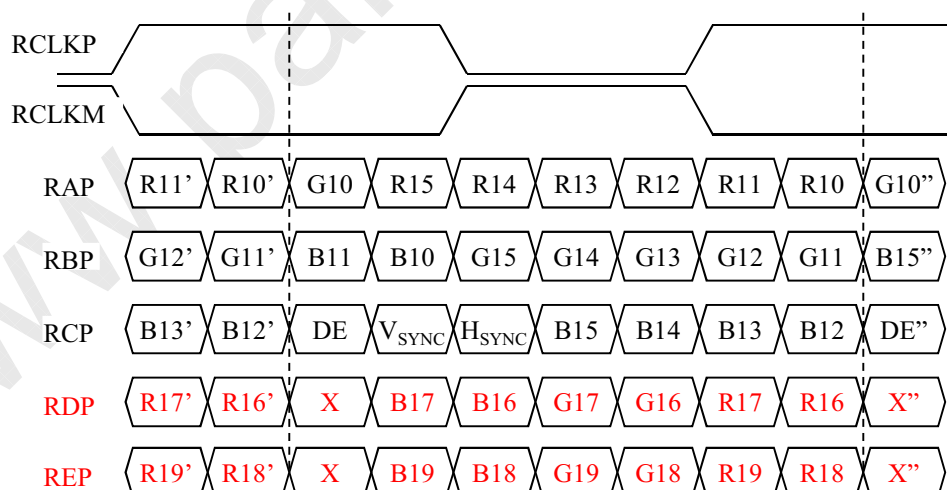

## Product Specification

## # APPENDIX- III-2

## ■ LVDS Data-Mapping Information (8 Bit )

## 1) LVDS Select : "H" Data-Mapping (JEIDA format)

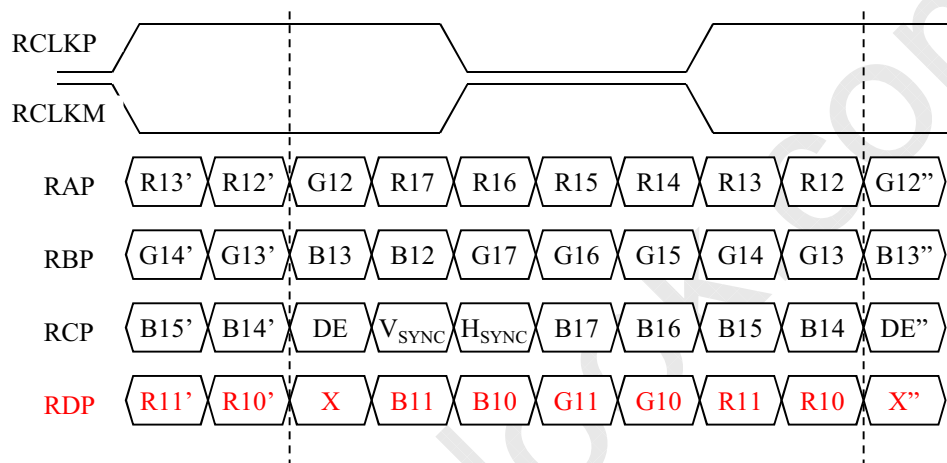

## 2) LVDS Select : "L" Data-Mapping (VESA format)

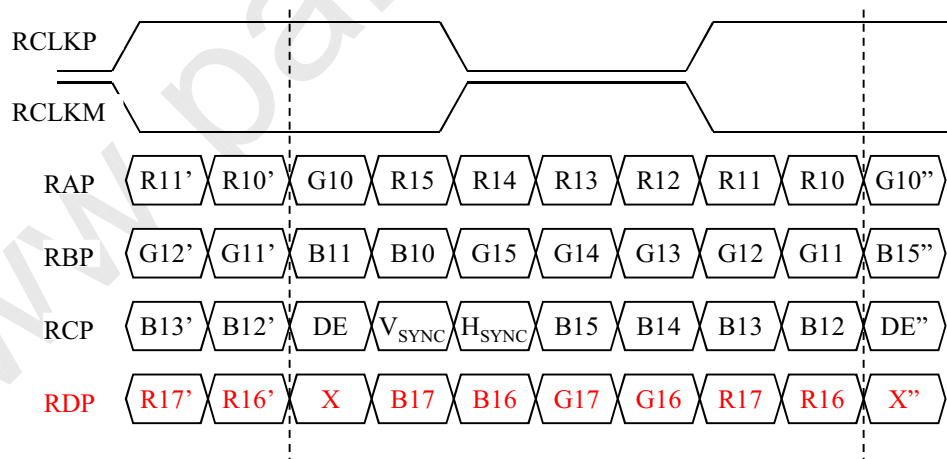

## # APPENDIX- III-3

## ■ Option Pin Circuit Block Diagram

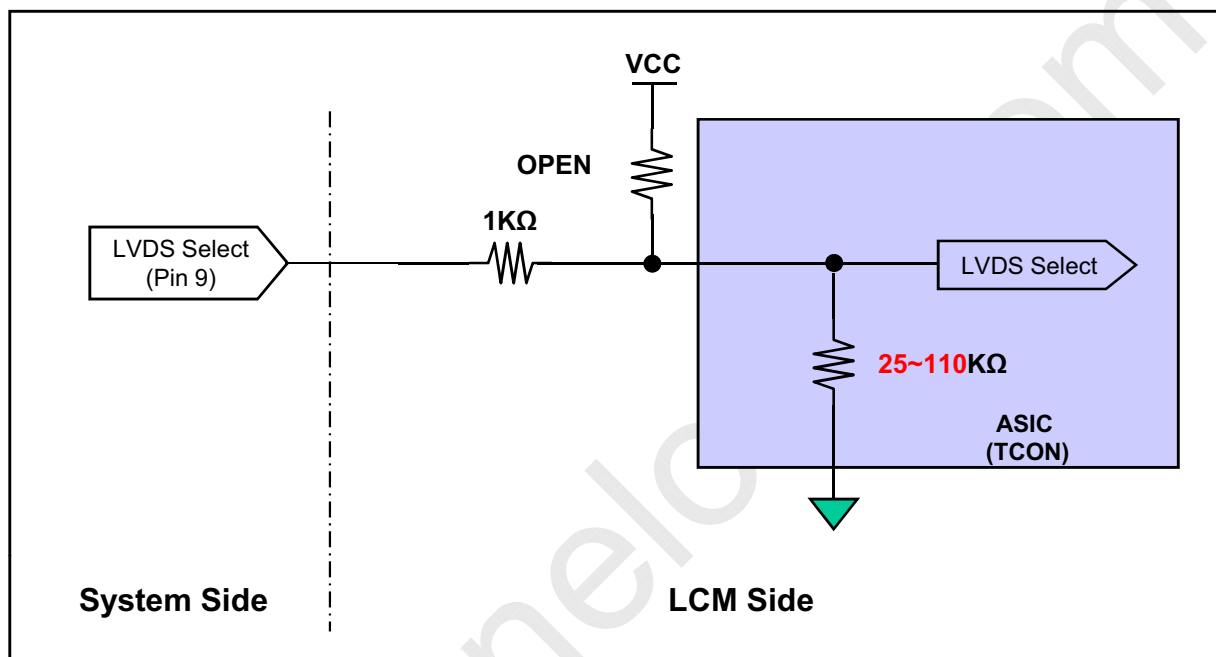
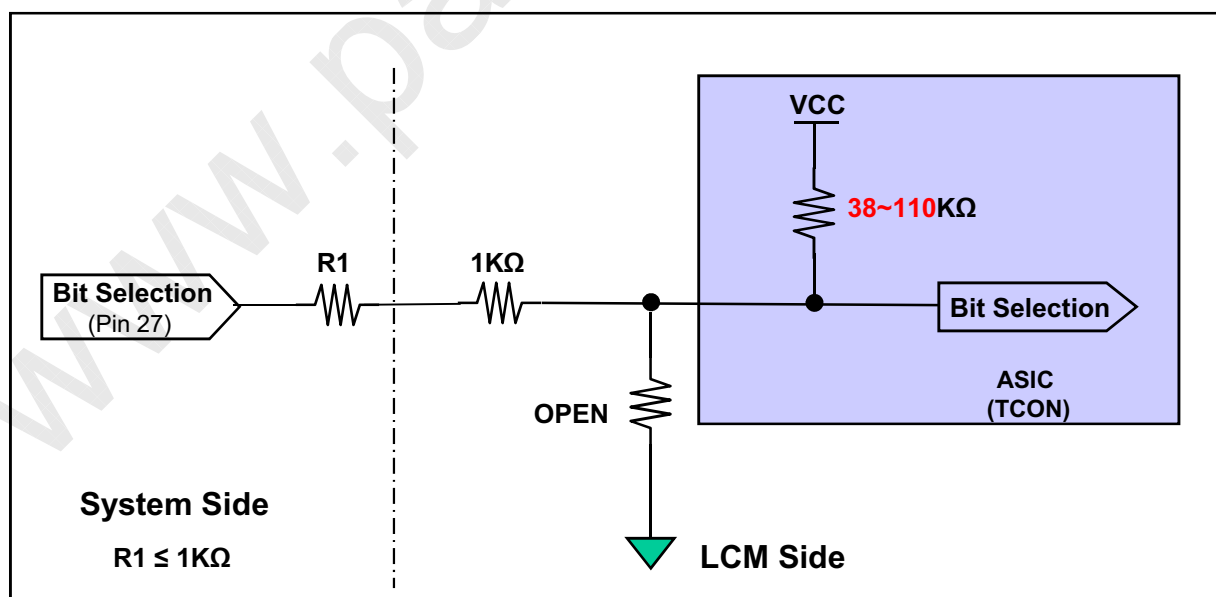
1) Circuit Block Diagram of **LVDS Format** Selection pin2) Circuit Block Diagram of **Bit Selection** pin

Product Specification

# APPENDIX- IV-1

■ Inverter 14<sup>th</sup> Pin (Status) Design Guide

1) Function of Status pin

- Purpose : Preventing of backlight off by restarting the inverter technically
- How to : When inverter is abnormal operation, TV system inputs the Von signal in the inverter once more to turn on the lamp safely
- Attention : Restart system's Von signal when status pin is high for some time (min:1sec , max:4sec).  
(The turn on time of lamp can be late such as the low temperature or the storage time)

2) Status operation modes in TV set

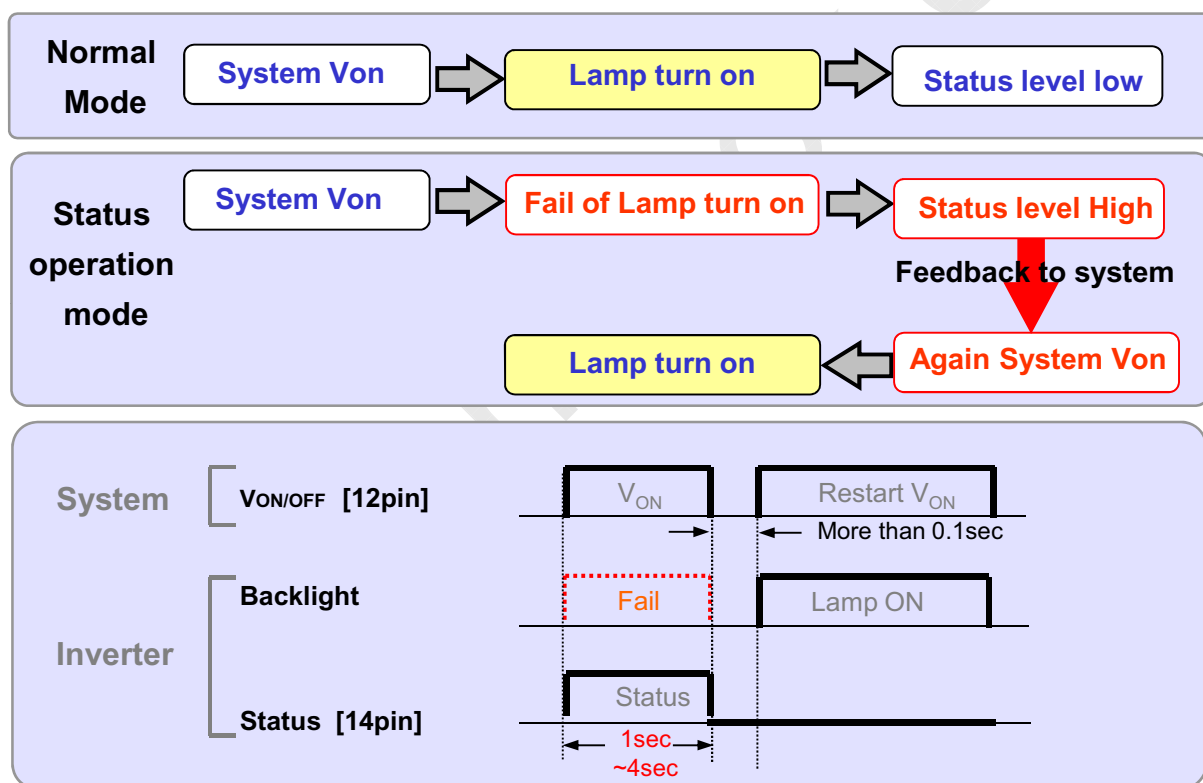

3) Inverter pin map

Pin No	Symbol	Description	Inv.
11	NC	No Connection	NC
12	VON/OFF	Backlight ON/OFF control	On/Off
13	EXTVBR-B	Burst Dimming Control PWM signal input	External PWM
14	Status	Normal : Under 0.7V / Abnormal : Upper 3.0V	status