

SPECIFICATION FOR APPROVAL

- () Preliminary Specification
- () Final Specification

Title	42.0" WXGA TFT LCD
--------------	---------------------------

BUYER	TTE
MODEL	

SUPPLIER	LG.Philips LCD Co., Ltd.
*MODEL	LC420WX4
SUFFIX	SLB1 (RoHS Verified)

*When you obtain standard approval,
please use the above model name without suffix

APPROVED BY	SIGNATURE DATE
/	
/	
/	

Please return 1 copy for your confirmation with
your signature and comments.

APPROVED BY	SIGNATURE DATE
J.H. Yoon / Senior Manager	
REVIEWED BY	
J.T. Kim / Manager	
PREPARED BY	
H.G. Jung / Engineer	

TV Product Development Dept.
LG. Philips LCD Co., Ltd

Product Specification

Contents

Number	ITEM	Page
	COVER	1
	CONTENTS	2
	RECORD OF REVISIONS	3
1	GENERAL DESCRIPTION	4
2	ABSOLUTE MAXIMUM RATINGS	5
3	ELECTRICAL SPECIFICATIONS	6
3-1	ELECTRICAL CHARACTERISTICS	6
3-2	INTERFACE CONNECTIONS	8
3-3	SIGNAL TIMING SPECIFICATIONS	10
3-4	SIGNAL TIMING WAVEFORMS	12
3-5	COLOR INPUT DATA REFERENCE	13
3-6	POWER SEQUENCE	14
4	OPTICAL SPECIFICATIONS	16
5	MECHANICAL CHARACTERISTICS	20
6	RELIABILITY	23
7	INTERNATIONAL STANDARDS	24
7-1	SAFETY	24
7-2	EMC	24
8	PACKING	25
8-1	DESIGNATION OF LOT MARK	25
8-2	PACKING FORM	25
9	PRECAUTIONS	26
9-1	MOUNTING PRECAUTIONS	26
9-2	OPERATING PRECAUTIONS	26
9-3	ELECTROSTATIC DISCHARGE CONTROL	27
9-4	PRECAUTIONS FOR STRONG LIGHT EXPOSURE	27
9-5	STORAGE	27
9-6	HANDLING PRECAUTIONS FOR PROTECTION FILM	27

Product Specification

1. General Description

LC420WX4 is a Color Active Matrix Liquid Crystal Display with an integral Cold Cathode Fluorescent Lamp(CCFL) backlight system. The matrix employs a-Si Thin Film Transistor as the active element. It is a transmissive type display operating in the normally black mode. It has a 40.02 inch diagonally measured active display area with WXGA resolution (768 vertical by 1366 horizontal pixel array) Each pixel is divided into Red, Green and Blue sub-pixels or dots which are arranged in vertical stripes. Gray scale or the luminance of the sub-pixel color is determined with a 8-bit or 10-bit gray scale signal for each dot, thus presenting a palette of more than 16.7M(true) or 1Billion(8bit+Dithering) of colors. It has been designed to apply the 8-bit 2 port or 10-bit 2 port LVDS interface. It is intended to support LCD TV, PCTV where high brightness, super wide viewing angle, high color gamut, high color depth and fast response time are important.

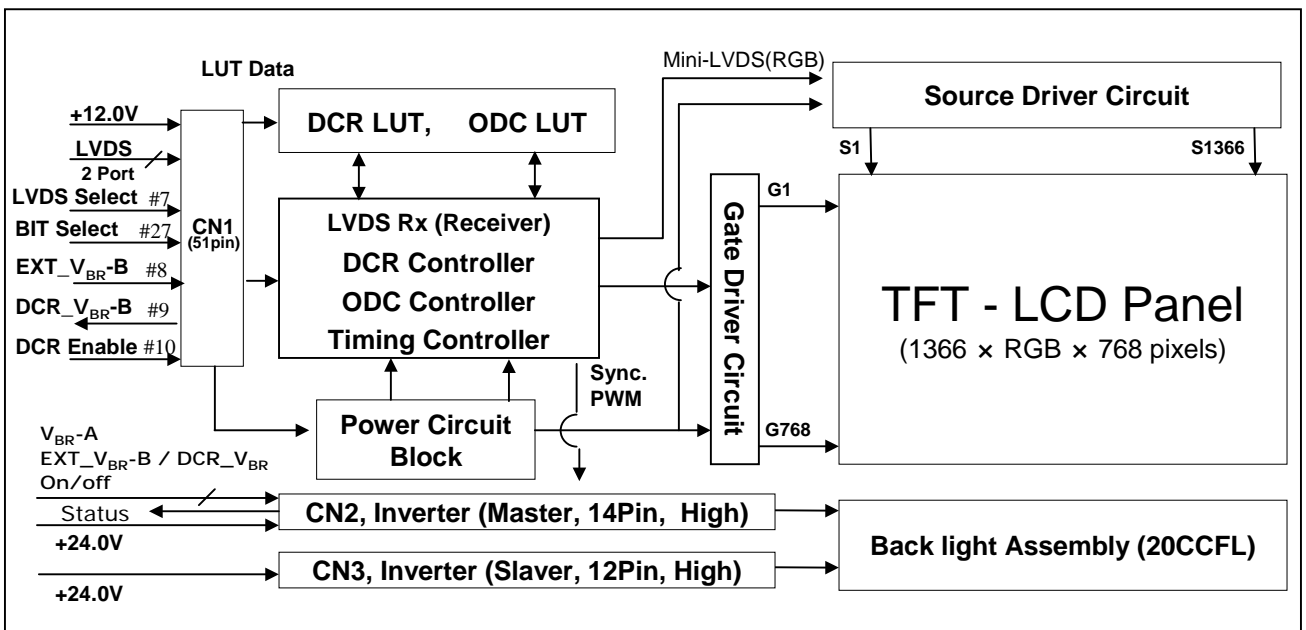

General Features

Active Screen Size	42.02 inches(1067.308mm) diagonal
Outline Dimension	983 mm(H) x 576 mm(V) x 51 mm(D) (Typ.)
Pixel Pitch	0.227mm x 0.681mm x RGB
Pixel Format	1366 horiz. by 768 vert. pixels RGB stripe arrangement
Color Depth	8-bit, 16.7 M / 10-bit, 1Billion colors
Luminance, White	500 cd/m ² (Center 1 point Typ.)
Viewing Angle (CR>10)	Viewing angle free (R/L 178(Typ.), U/D 178(Typ.))
Power Consumption	Total 183.2 Watt (Typ.) (Logic= 8.2W, Lamp= 171W [I _{BL} =6.5mA])
Weight	13.0Kg (Typ.)
Display Operating Mode	Transmissive mode, Normally black
Surface Treatment	Hard coating(3H), Anti-glare treatment of the front polarizer

Product Specification

2. Absolute Maximum Ratings

The followings are maximum values which, if exceeded, may cause faulty operation or damage to the unit.

Table 1. ABSOLUTE MAXIMUM RATINGS

Parameter		Symbol	Value		Unit	Remark
			Min	Max		
Power Input Voltage	LCM	V_{LCD}	-0.3	14.0	V_{DC}	at $25 \pm 2 \text{ }^\circ\text{C}$
	Backlight inverter	V_{BL}	21.6	27.0	V_{DC}	When operating
Option input voltage(select)		V_I	-0.3	3.6	V_{DC}	#7, #10, #27 Pin
ON/OFF Control Voltage		$V_{ON/OFF}$	-0.3	5.5	-	
Brightness Control Voltage		V_{BR}	0.0	5.0	-	
Operating Temperature		T_{OP}	0	40		Note 2
Storage Temperature		T_{ST}	-20	50		Note 1
Operating Ambient Humidity		H_{OP}	10	90	%RH	
Storage Humidity		H_{ST}	10	90	%RH	

Note : 1. Temperature and relative humidity range are shown in the figure below.
Wet bulb temperature should be 39 °C Max. and no condensation of water.

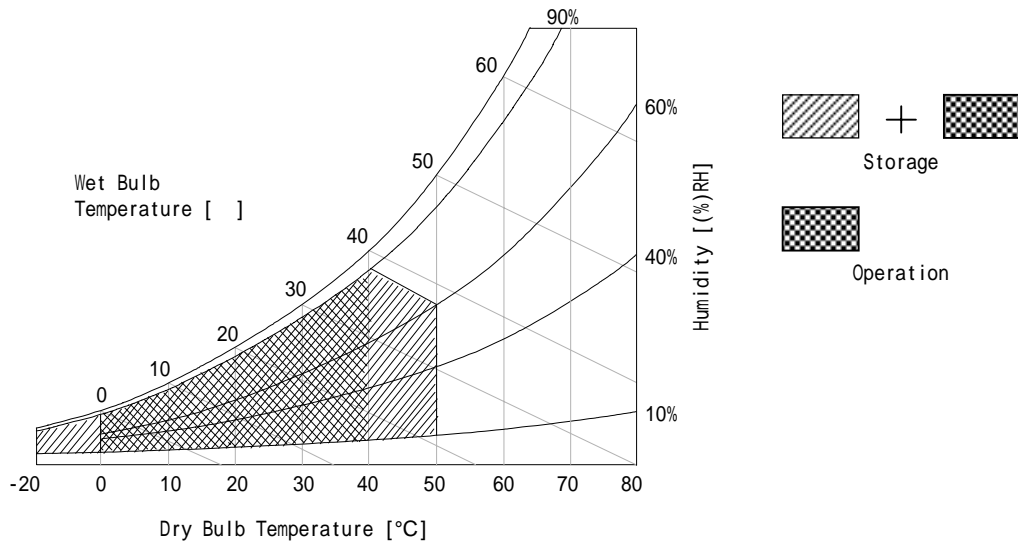

Product Specification

3. Electrical Specifications

3-1. Electrical Characteristics

It requires two power inputs. One is employed to power the LCD electronics and to drive the TFT array and liquid crystal. The other input power for the CCFL/Backlight is to power inverter.

Table 2_1. ELECTRICAL CHARACTERISTICS

Parameter	Symbol	Value			Unit	Note
		Min	Typ	Max		
MODULE :						
Power Input Voltage	VLCD	11.4	12.0	12.6	Vdc	
Power Input Current	ILCD	-	680	884	mA	1
		-	884	1149.2	mA	2
Power Consumption	PLCD	-	8.2	10.6	Watt	1
Rush current	IRUSH	-	-	3.5	A	3

Note :

1. The specified current and power consumption are under the $V_{LCD}=12.0V$, $25 \pm 2^{\circ}C$, $f_v=120Hz$ condition whereas mosaic pattern(8 x 6) is displayed and f_v is the frame frequency.
2. The current is specified at the maximum current pattern.
3. The duration of rush current is about 2ms and rising time of power Input is 1ms(min.).

White : 255Gray(1023Gray)
Black : 0Gray

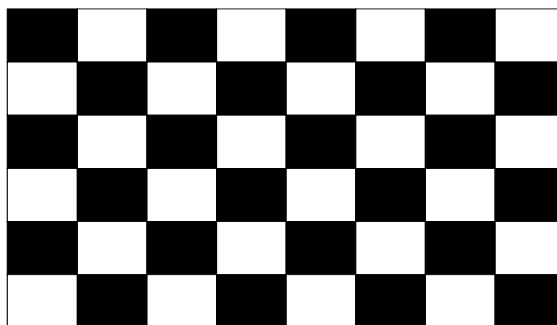

Mosaic Pattern(8 x 6)

Product Specification

Table 2_2. ELECTRICAL CHARACTERISTICS

Parameter	Symbol	Condition	Value			Unit	Note
			Min.	Typ.	Max.		
Inverter :							
Input Voltage	V_{BL}		22.8	24.0	25.4	V_{DC}	
Input Current	I_{BL}	$V_{BR-A(max)} = 3.3V$	-	7.6	8.6	A	1
		$V_{BR-A(Typ)} = 1.65V$	-	7.1	8.1	A	1
Power Supply Input Current (In-Rush)	I_{RUSH}	$V_{BL}=22.8V$ $V_{BR-A}=1.65V$ $EXT_V_{BR-B}=3.3V$	-	-	13	A	
Power Consumption	P_{BL}	$V_{BR-A} = 1.65V$	-	171	194.5	Watt	1
B/L on/off control	$V_{ON/OFF}$	Lamp ON = High	2.5	-	5.0	V_{DC}	
		Lamp OFF =Low	-0.3		0.8	V_{DC}	
Brightness Adj (Analog mode)	V_{BR-A}		0	1.65	3.3	V_{DC}	
Brightness Adj (Burst mode)	V_{BR-B}		0	-	3.3	V_{DC}	
Life Time			50,000			Hrs	2

Notes :

- Electrical characteristics are determined after the unit has been 'ON' and stable for approximately 120 minutes at $25 \pm 2^{\circ}C$.
The specified current and power consumption are under the typical supply condition (Input voltage 24V , V_{br-A} 1.65V and V_{br-B} 3.3V)
The ripple voltage of the power supply input voltage is under 0.5 Vp-p. LPL recommend Input Voltage is $4.0V \pm 5\%$.
- Specified values are for a single lamp which is aligned horizontally.
The life is determined as the time at which luminance of the lamp is 50% compared to that of initial value at the typical lamp current ($V_{BR-A} = 1.65V$) on condition of continuous operating at $25 \pm 2^{\circ}C$.
Specified value is when lamp is aligned horizontally.

Product Specification

3-2. Interface Connections

This LCD module employs two kinds of interface connection, a 51-pin connector is used for the module electronics ,14-pin and 12-pin connectors are used for the integral backlight system.

3-2-1. LCD Module

- LCD Connector(CN1): FI-RE51S-HF or Equivalent
- Mating Connector : FI-RE51HL or Equivalent

Table 3. MODULE CONNECTOR(CN1) PIN CONFIGURATION

No	Symbol	Description	No	Symbol	Description
1	GND	Ground	27	BIT Select	Logic 'L' : 8bit, 'H' or 'NC' : 10bit
2	NC	Reserved	28	RE0N	SECOND CHANNEL 0-
3	NC	Reserved	29	RE0P	SECOND CHANNEL 0+
4	NC	(I2C DATA Interface)	30	RE1N	SECOND CHANNEL 1-
5	NC	(I2C CLK Interface)	31	RE1P	SECOND CHANNEL 1+
6	NC	(EEPROM Write Protection)	32	RE2N	SECOND CHANNEL 2-
7	LVDS Select	Logic 'L' or 'NC' :LG, 'H' : DISM	33	RE2P	SECOND CHANNEL 2+
8	EXT_V _{BR} -B	EXT_V _{BR} -B Input	34	GND	Ground
9	DCR_V _{BR} -B	DCR_V _{BR} -B Output	35	RECLKN	SECOND CLOCK CHANNEL C-
10	DCR Enable	Logic 'L' Level : Disable	36	RECLKP	SECOND CLOCK CHANNEL C+
11	GND	Ground	37	GND	Ground
12	RO0N	FIRST CHANNEL 0-	38	RE3N	SECOND CHANNEL 3-
13	RO0P	FIRST CHANNEL 0+	39	RE3P	SECOND CHANNEL 3+
14	RO1N	FIRST CHANNEL 1-	38	RE4N	SECOND CHANNEL 4-
15	RO1P	FIRST CHANNEL 1+	39	RE4P	SECOND CHANNEL 4+
16	RO2N	FIRST CHANNEL 2-	42	GND	Ground
17	RO2N	FIRST CHANNEL 2+	43	GND	Ground
18	GND	Ground	44	GND	Ground (NSB)
19	ROCLKN	FIRST CLOCK CHANNEL C-	45	GND	Ground
20	ROCLKP	FIRST CLOCK CHANNEL C+	46	GND	Ground
21	GND	Ground	47	NC	No connection
22	RO3N	FIRST CHANNEL 3-	48	V _{LCD}	Power Supply +12.0V
23	RO3P	FIRST CHANNEL 3+	49	V _{LCD}	Power Supply +12.0V
24	RO4N	FIRST CHANNEL 4-	50	V _{LCD}	Power Supply +12.0V
25	RO4P	FIRST CHANNEL 4+	51	V _{LCD}	Power Supply +12.0V
26	GND	Ground	-	-	-

- Note :
1. All GND(ground) pins should be connected together to the LCD module's metal frame.
 2. All V_{LCD} (power input) pins should be connected together.
 3. All Input levels of LVDS signals are based on the IEA 664 Standard.
 4. Specific pins(pin No. #2~#6) are used for internal data process of the LCD module.
If not used, these pins are no connection.
 5. Specific pins(pin No. #8~#9) are used for DCR test of the LCD module.
If not used, these pins are no connection.
 6. Specific pin No. #44 is used for for "No signal detection" of system signal interface.
It should be GND for NSB(No Signal Black) during the system interface signal is not.
If this pin is "H", LCD Module displays AGP(Auto Generation Pattern).

Product Specification

3-2-2. Backlight Inverter

The inverter connector is S14B-PH-SMC-TB top entry type (manufactured by JST) or equivalent. The pin configuration for the 14 pin connector is shown in the table below.

Table 5. INVERTER CONNECTOR PIN CONFIGURATION

Pin	Symbol	Signal assignment		Note
		Master(CN2)	Slave(CN3)	
1	VBL	24V Power Input	24V Power Input	
2	VBL	24V Power Input	24V Power Input	
3	VBL	24V Power Input	24V Power Input	
4	VBL	24V Power Input	24V Power Input	
5	VBL	24V Power Input	24V Power Input	
6	GND	GROUND	GROUND	
7	GND	GROUND	GROUND	
8	GND	GROUND	GROUND	
9	GND	GROUND	GROUND	
10	GND	GROUND	GROUND	
11	V_{BR-A}	Analog dimming voltage to control current amplitude	Don't care	0V : 90% (min) 1.65V : 100% (Typ) 3.3V : 110% (max) Open(NC) : 1.65V
12	$V_{ON/OFF}$	Backlight ON/OFF control	Don't care	ON : 2.5 ~ 5.0V OFF : 0.0 ~ 0.8V
13	V_{BR-B}	Burst dimming Voltage to control PWM duty	No Pin	0V : 20% (min) 3.3V : 100% (max)
14	Status	Using Status output	No pin	Upper 3.0V output (Normal), Under 0.7V output (Abnormal)

1. Connector

- 1) Connector(Receptacle)
: S14B-PH-SMC-TB (JST) &
S12B-PH-SMC-TB (JST)
- 2) Mating Connector(Plug)
: PHR14 (JST) &
PHR12 (JST)

* JST : Japan solderless Terminal Co.,Ltd.

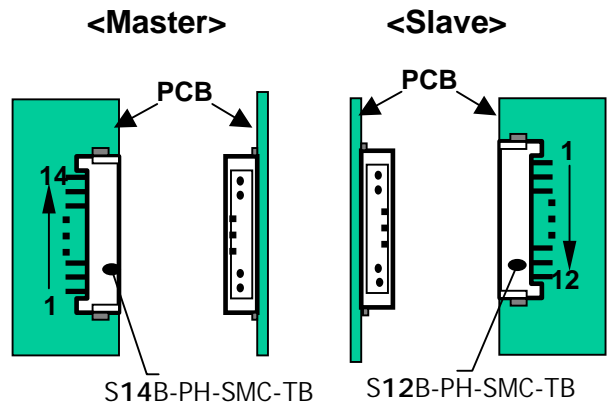

Product Specification

3-3. Signal Timing Specifications

Table 6 shows the signal timing required at the input of the LVDS transmitter. All of the interface signal timing should be satisfied with the following specification for normal operation.

Table 6. TIMING TABLE for NTSC (DE Only Mode)

ITEM		Symbol	Min	Typ	Max	Unit	Note
Horizontal	Display Period	t_{HV}	683	683	683	t_{CLK}	1366/2
	Back Porch	t_{HBP}	-	24	-	t_{CLK}	
	Front Porch	t_{HFP}	-	32	-	t_{CLK}	
	Blank	t_{HB}	64	80	96	t_{CLK}	1
	Total	t_{HP}	747	763	779	t_{CLK}	
Vertical	Display Period	t_{VV}	768	768	768	Lines	
	Back Porch	t_{VBP}	-	10	-	Lines	
	Front Porch	t_{VFP}	-	7	-	Lines	
	Blank	t_{VB}	7	22	37	Lines	1
	Total	t_{VP}	775	790	805	Lines	

ITEM		Symbol	Min	Typ	Max	Unit	Note
Frequency	DCLK	f_{CLK}	68	72.4	80	MHz	
	Horizontal	f_H	89	94.6	100	KHz	2
	Vertical	f_V	117	120	123	Hz	2

- Note :
1. The Input of HSYNC & VSYNC signal does not have an effect on normal operation(DE Only Mode). If you use spread spectrum for EMI, add some additional clock to minimum value for clock margin.
 2. The performance of the electro-optical characteristics may be influenced by variance of the vertical refresh rate and the horizontal frequency.
 3. Timing should be set based on clock frequency.

Product Specification

Table 7 shows the signal timing required at the input of the LVDS transmitter. All of the interface signal timing should be satisfied with the following specification for normal operation.

Table 7. TIMING TABLE for PAL (DE Only Mode)

ITEM		Symbol	Min	Typ	Max	Unit	Note
Horizontal	Display Period	t_{HV}	683	683	683	t_{CLK}	1366/2
	Back Porch	t_{HBP}	-	24	-	t_{CLK}	
	Front Porch	t_{HFP}	-	32	-	t_{CLK}	
	Blank	t_{HB}	64	80	96	t_{CLK}	1
	Total	t_{HP}	747	763	779	t_{CLK}	
Vertical	Display Period	t_{VV}	768	768	768	Lines	
	Back Porch	t_{VBP}	-	10	-	Lines	
	Front Porch	t_{VFP}	-	7	-	Lines	
	Blank	t_{VB}	7	22	37	Lines	1
	Total	t_{VP}	775	790	805	Lines	

ITEM		Symbol	Min	Typ	Max	Unit	Note
Frequency	DCLK	f_{CLK}	56	60.4	67	MHz	
	Horizontal	f_H	74	79	84	KHz	2
	Vertical	f_V	97	100	103	Hz	2

- Note :
1. The Input of HSYNC & VSYNC signal does not have an effect on normal operation(DE Only Mode). If you use spread spectrum for EMI, add some additional clock to minimum value for clock margin.
 2. The performance of the electro-optical characteristics may be influenced by variance of the vertical refresh rate and the horizontal frequency.
 3. Timing should be set based on clock frequency.

3-4. Signal Timing Waveforms

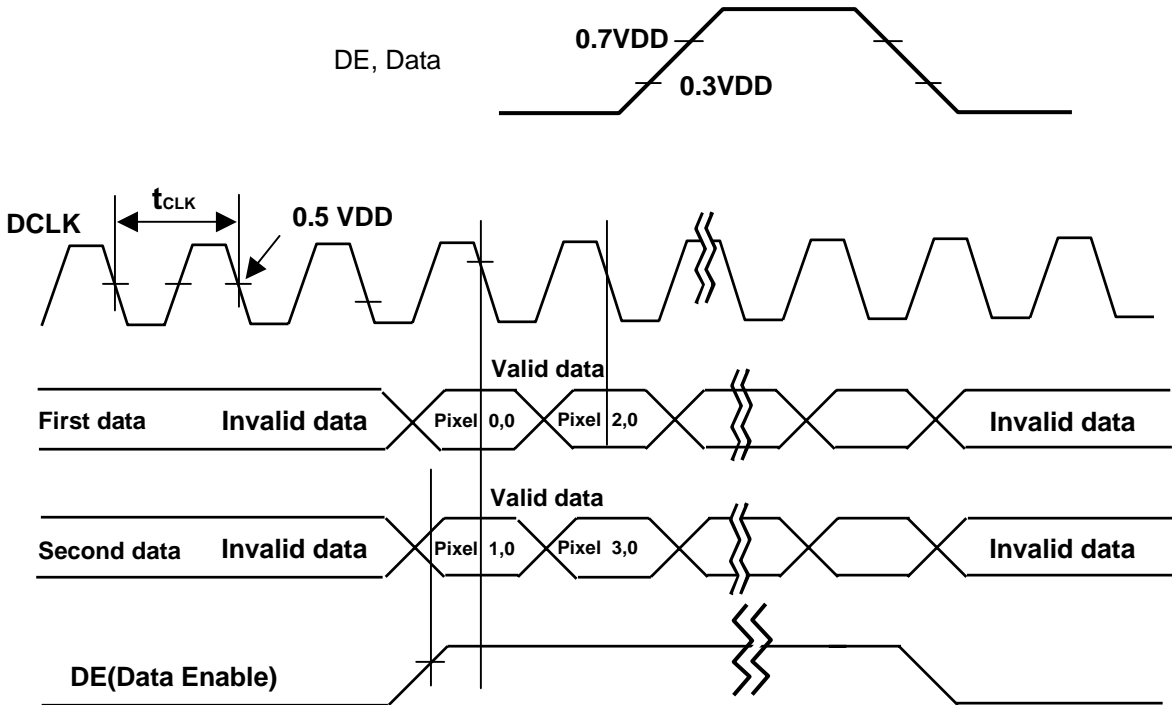

* Reference : Sync. Relation

$$* t_{HB} = t_{HFP} + t_{WH} + t_{HBP}$$

$$* t_{VB} = t_{VFP} + t_{WV} + t_{VBP}$$

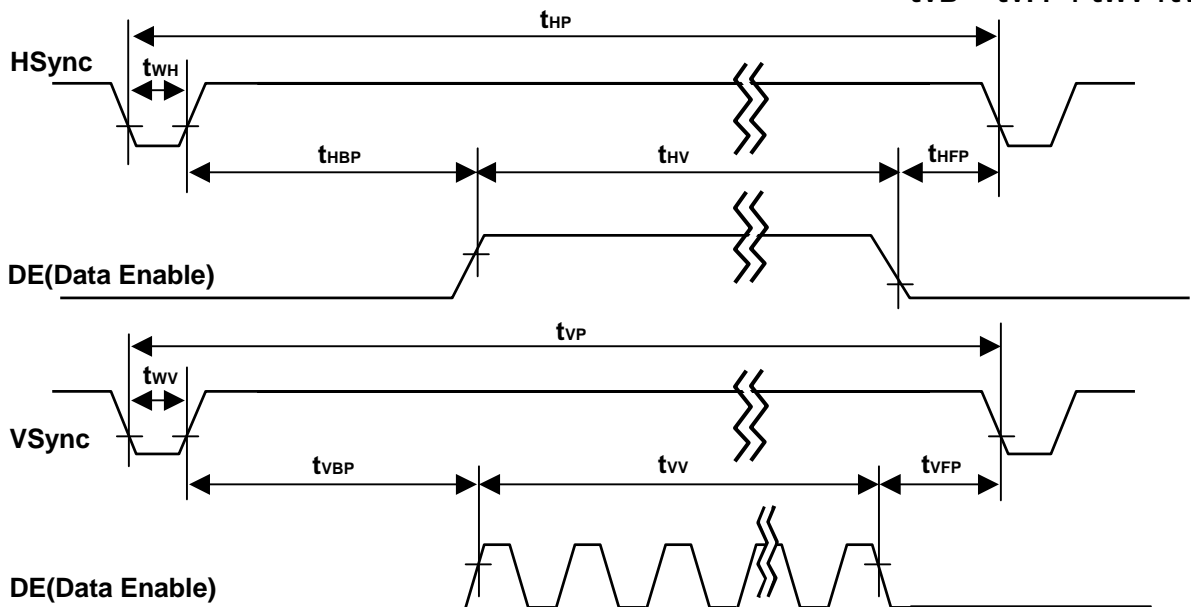

Product Specification

3-5. Color Data Reference

The brightness of each primary color(red,green,blue) is based on the 10-bit gray scale data input for the color. The higher binary input, the brighter the color. Table 8 provides a reference for color versus data input. 8-bit operation should be supplied 8-digit data of MSB.

Table 8. COLOR DATA REFERENCE

Color		Input Color Data																													
		RED										GREEN										BLUE									
		MSB					LSB					MSB					LSB					MSB					LSB				
		R9	R8	R7	R6	R5	R4	R3	R2	R1	R0	G9	G8	G7	G6	G5	G4	G3	G2	G1	G0	B9	B8	B7	B6	B5	B4	B3	B2	B1	B0
Basic Color	Black	0	0	0	0	0	0	0	0	0	0	0	0	0	0	0	0	0	0	0	0	0	0	0	0	0	0	0	0	0	0
	Red (1023)	1	1	1	1	1	1	1	1	1	1	0	0	0	0	0	0	0	0	0	0	0	0	0	0	0	0	0	0	0	0
	Green (1023)	0	0	0	0	0	0	0	0	0	0	1	1	1	1	1	1	1	1	1	1	0	0	0	0	0	0	0	0	0	0
	Blue (1023)	0	0	0	0	0	0	0	0	0	0	0	0	0	0	0	0	0	0	0	0	1	1	1	1	1	1	1	1	1	1
	Cyan	0	0	0	0	0	0	0	0	0	0	1	1	1	1	1	1	1	1	1	1	1	1	1	1	1	1	1	1	1	1
	Magenta	1	1	1	1	1	1	1	1	1	1	0	0	0	0	0	0	0	0	0	0	1	1	1	1	1	1	1	1	1	1
	Yellow	1	1	1	1	1	1	1	1	1	1	1	1	1	1	1	1	1	1	1	1	0	0	0	0	0	0	0	0	0	0
	White	1	1	1	1	1	1	1	1	1	1	1	1	1	1	1	1	1	1	1	1	1	1	1	1	1	1	1	1	1	1
RED	RED (0000)	0	0	0	0	0	0	0	0	0	0	0	0	0	0	0	0	0	0	0	0	0	0	0	0	0	0	0	0	0	
	RED (0001)	0	0	0	0	0	0	0	0	0	0	0	0	0	0	0	0	0	0	0	0	0	0	0	0	0	0	0	0	0	
									
	RED (1022)	1	1	1	1	1	1	1	1	1	0	0	0	0	0	0	0	0	0	0	0	0	0	0	0	0	0	0	0	0	0
	RED (1023)	1	1	1	1	1	1	1	1	1	1	0	0	0	0	0	0	0	0	0	0	0	0	0	0	0	0	0	0	0	0
GREEN	GREEN (0000)	0	0	0	0	0	0	0	0	0	0	0	0	0	0	0	0	0	0	0	0	0	0	0	0	0	0	0	0	0	
	GREEN (0001)	0	0	0	0	0	0	0	0	0	0	0	0	0	0	0	0	0	0	0	0	0	0	0	0	0	0	0	0	0	
									
	GREEN (1022)	0	0	0	0	0	0	0	0	0	0	1	1	1	1	1	1	1	1	1	0	0	0	0	0	0	0	0	0	0	0
	GREEN (1023)	0	0	0	0	0	0	0	0	0	0	1	1	1	1	1	1	1	1	1	1	0	0	0	0	0	0	0	0	0	0
BLUE	BLUE (0000)	0	0	0	0	0	0	0	0	0	0	0	0	0	0	0	0	0	0	0	0	0	0	0	0	0	0	0	0	0	
	BLUE (0001)	0	0	0	0	0	0	0	0	0	0	0	0	0	0	0	0	0	0	0	0	0	0	0	0	0	0	0	0	1	
									
	BLUE (1022)	0	0	0	0	0	0	0	0	0	0	0	0	0	0	0	0	0	0	0	0	1	1	1	1	1	1	1	1	0	0
	BLUE (1023)	0	0	0	0	0	0	0	0	0	0	0	0	0	0	0	0	0	0	0	0	1	1	1	1	1	1	1	1	1	1

Product Specification

3-6. Power Sequence

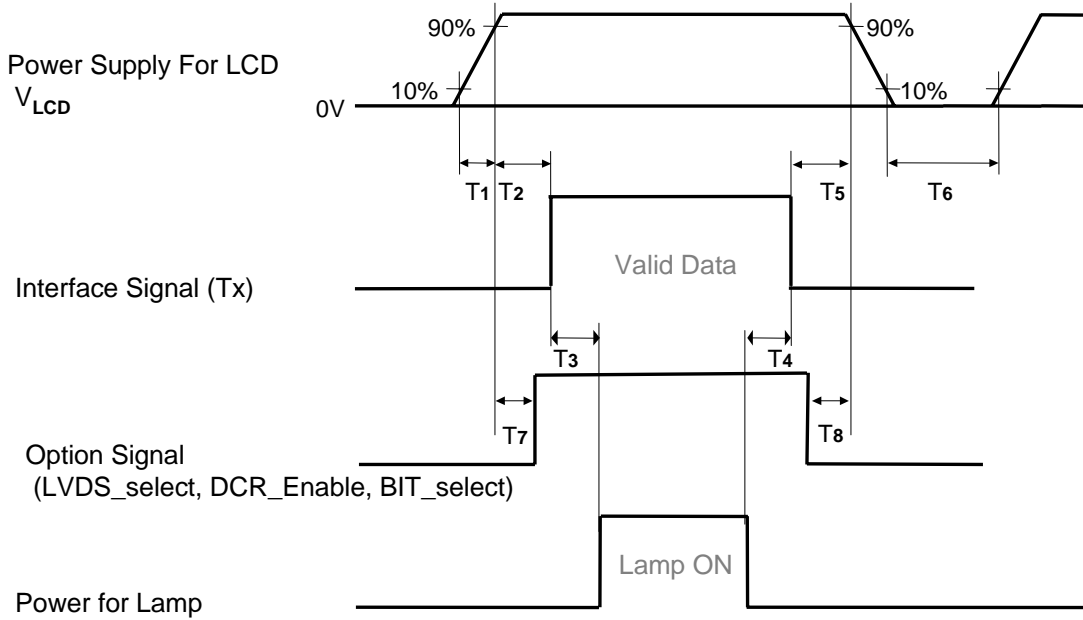

Table 9. POWER SEQUENCE

Parameter	Value			Unit
	Min	Typ	Max	
T1	1.0	-	20	ms
T2	0.5	-	25	ms
T3	200	-	-	ms
T4	200	-	-	ms
T5	0.5	-	25	ms
T6	1.0	-	-	s
T7	0 < T8 < T2			ms
T8	0 < T9 < T5			ms

- Note :
1. Please avoid floating state of interface signal at invalid period.
 2. When the interface signal is invalid, be sure to pull down the power supply V_{LCD} to 0V.
 3. The case when the T2/T5 exceed maximum specification, it operates protection pattern(Black pattern) till valid signal inputted. There is no reliability problem.
 4. The T3/T4 is recommended value, the case when failed to meet a minimum specification, abnormal display would be shown. There is no reliability problem.
 5. If the on time of option signal(DISM or DCR_Enable) precedes the on time of Power(V_{LCD}), check the LCD logic Power(V_{cc}) is under 0.8V, otherwise it will be happened abnormal display.
 6. T6 should be measured after the Module has been fully discharged between power off and on period

Product Specification

3-6-2. On/Off for Inverter

Power Supply For Inverter

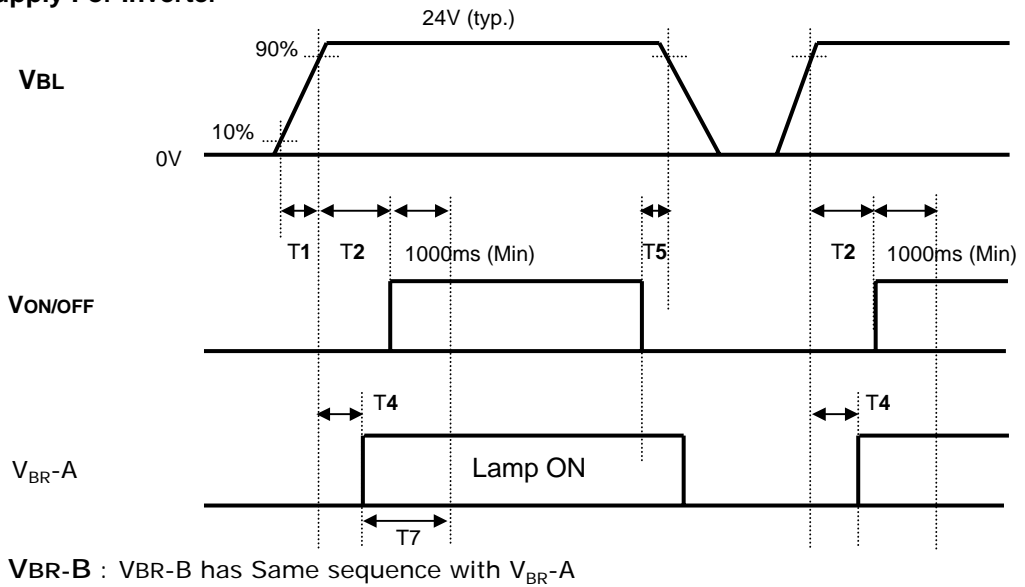

3-6-3. Deep condition for Inverter

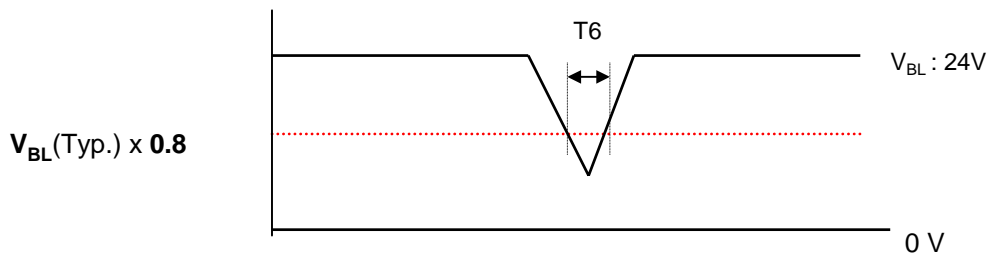

Table 11. Power Sequence for Inverter

Parameter	Values			Units	Remarks
	Min	Typ	Max		
T1	20	-	-	ms	1
T2	500	-	-	ms	
T4	0	-	-	ms	2
T5	10	-	-	ms	
T6	-	-	10	ms	V _{BL} (Typ.) x 0.8
T7	1000	-	-	ms	3

- Notes :
1. T1 describes rising time of 0V to 24V and is not applied at restarting time.
 2. T4(max) is less than T2.
 3. In T7 section, VBR-B should be duty 100%.
 4. When V_{BL}[24V] is supplied always, there is no reliability problem.

Product Specification

4. Optical Specification

Optical characteristics are determined after the unit has been 'ON' for 120min in a dark environment at $25 \pm 2^\circ\text{C}$. The values specified are at an approximate distance 50cm from the LCD surface at a viewing angle of Φ and θ equal to 0° .

It is presented additional information concerning the measurement equipment and method in FIG. 1.

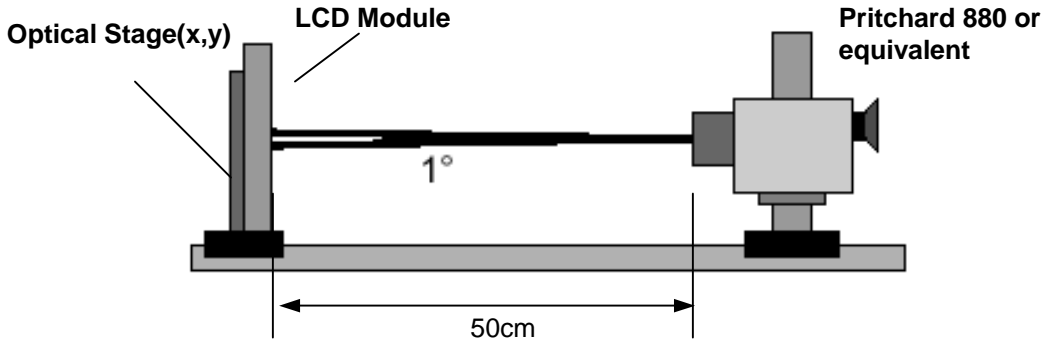

FIG. 1 Optical Characteristic Measurement Equipment and Method

Table 11. OPTICAL CHARACTERISTICS

$T_a = 25 \pm 2^\circ\text{C}$, $V_{LCD} = 12.0\text{V}$, $f_v = 120\text{Hz}$, $D_{clk} = 72\text{MHz}$, $V_{BR} = 3.3\text{V}$

Parameter	Symbol	Value			Unit	Note	
		Min	Typ	Max			
Contrast Ratio	CR	700	1,000	-		1	
	DCR	3,500	5,000	-			
Surface Luminance, white	L_{WH}	400	500	-	cd/m ²	2	
Luminance Variation	δ_{WHITE} 5P	-	-	1.3		3	
Response Time	MPRT	-	8	10	ms	4	
	G to G	-	5	10	ms	4	
Color Coordinates [CIE1931]	RED	Rx	Typ -0.03	0.637	Typ +0.03		
		Ry		0.343			
	GREEN	Gx		0.289			
		Gy		0.616			
	BLUE	Bx		0.145			
		By		0.064			
	WHITE	Wx		0.279			
	Wy	0.292					
Viewing Angle (CR>10)							
	x axis, right($\phi=0^\circ$)	θ_r	85	89	-	degree	5
	x axis, left ($\phi=180^\circ$)	θ_l	85	89	-		
	y axis, up ($\phi=90^\circ$)	θ_u	85	89	-		
	y axis, down ($\phi=270^\circ$)	θ_d	85	89	-		
Gray Scale						6	

Product Specification

Notes 1. Contrast Ratio(CR) is defined mathematically as :

CR (Contrast Ratio) = Maximum CR_n (n=1, 2, 3, 4, 5)
DCR (Dynamic CR) = Maximum CR_n (n=1, 2, 3, 4, 5)

$$CR_n = \frac{\text{Surface Luminance at position n with all white pixels}}{\text{Surface Luminance at position n with all black pixels}}$$

n = the Position number(1, 2, 3, 4, 5), For more information, see FIG 2.

2. Surface luminance is luminance value at the center point across the LCD surface 50cm from the surface with all pixels displaying white.
For more information, see FIG 2.
3. The variation in surface luminance , δ WHITE is defined as :

$$\delta \text{ WHITE}(5P) = \text{Maximum}(L_{on1}, L_{on2}, L_{on3}, \dots, L_{on5}) / \text{Minimum}(L_{on1}, L_{on2}, L_{on3}, \dots, L_{on5})$$
 Where L_{on1} to L_{on5} are the luminance with all pixels displaying white at 5 locations .
For more information, see FIG 2.
4. MPRT is defined as the 10% to 90% blur-edge width Bij(pixels) and scroll speed U(pixels/frame)at the moving picture. For more information, see FIG 3.
5. Viewing angle is the angle at which the contrast ratio is greater than 10. The angles are determined for the horizontal or x axis and the vertical or y axis with respect to the z axis which is normal to the LCD surface. For more information, see FIG 4.
6. Gray scale specification
Gamma Value is approximately 2.2.
For more information, see Table 12.

Table 12. GRAY SCALE SPECIFICATION

Gray Level		Luminance [%] (Typ) [Normal]	Luminance [%] (Typ) [DCR]
8bit	10bit		
L0	L0	0.10	0.02 ($V_{BR-A} = 0V, V_{BR-B} = 0V$)
L15	L63	0.29	
L31	L127	1.06	
L47	L191	2.50	
L63	L255	4.69	
L79	L319	7.66	
L95	L383	11.45	DCR gray scale is according to inverter dimming voltages.
L111	L447	16.1	
L127	L511	21.6	
L143	L575	28.1	
L159	L639	35.4	
L175	L703	43.7	
L191	L767	53.0	
L207	L831	63.2	
L223	L895	74.5	
L239	L959	86.7	
L255	L1023	100	100 ($V_{BR-A} = 3.3V, V_{BR-B} = 3.3V$)

Measuring point for surface luminance & measuring point for luminance variation

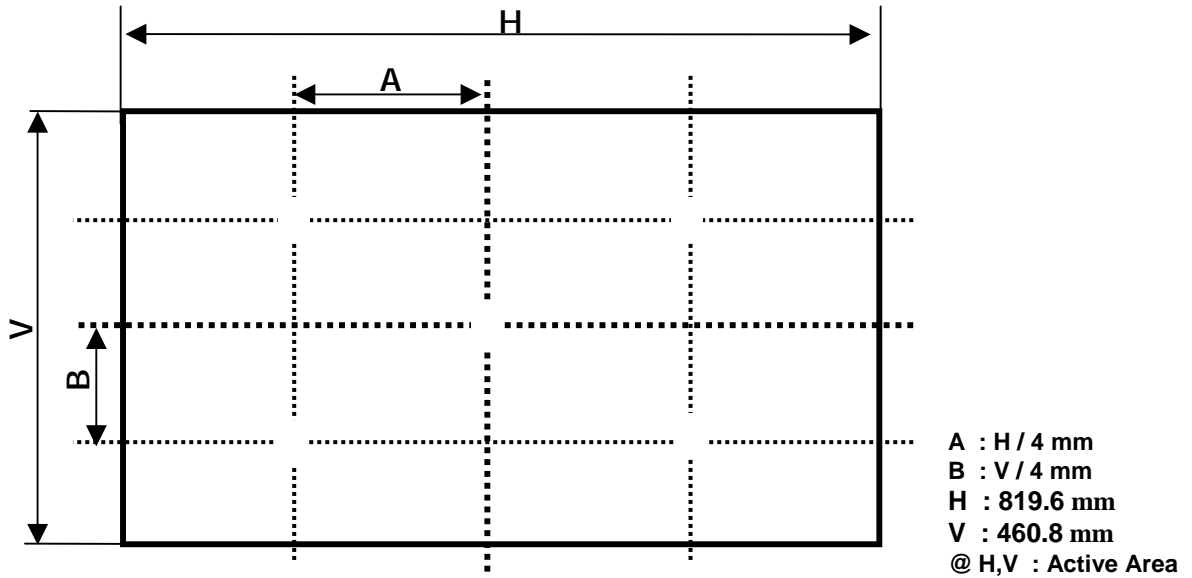

FIG. 2 Measure Point for Luminance

MPRT is defined as the 10% to 90% blur-edge with B_{ij} (pixels) and scroll speed U (pixels/frame)at the moving picture.

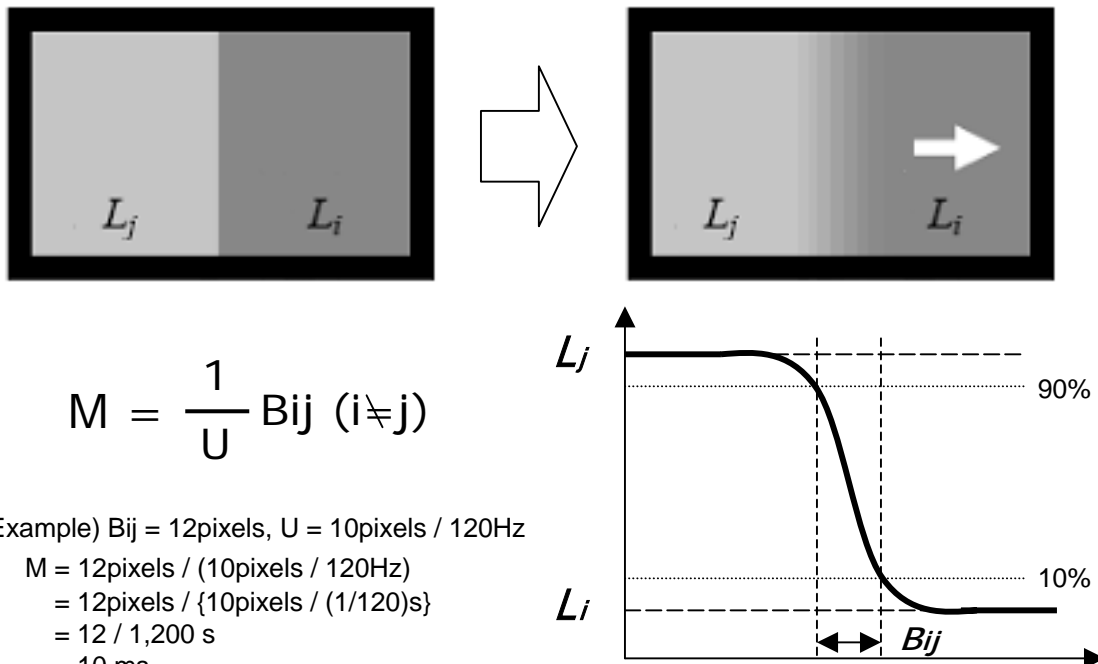

FIG. 3 MPRT

Product Specification

Dimension of viewing angle range

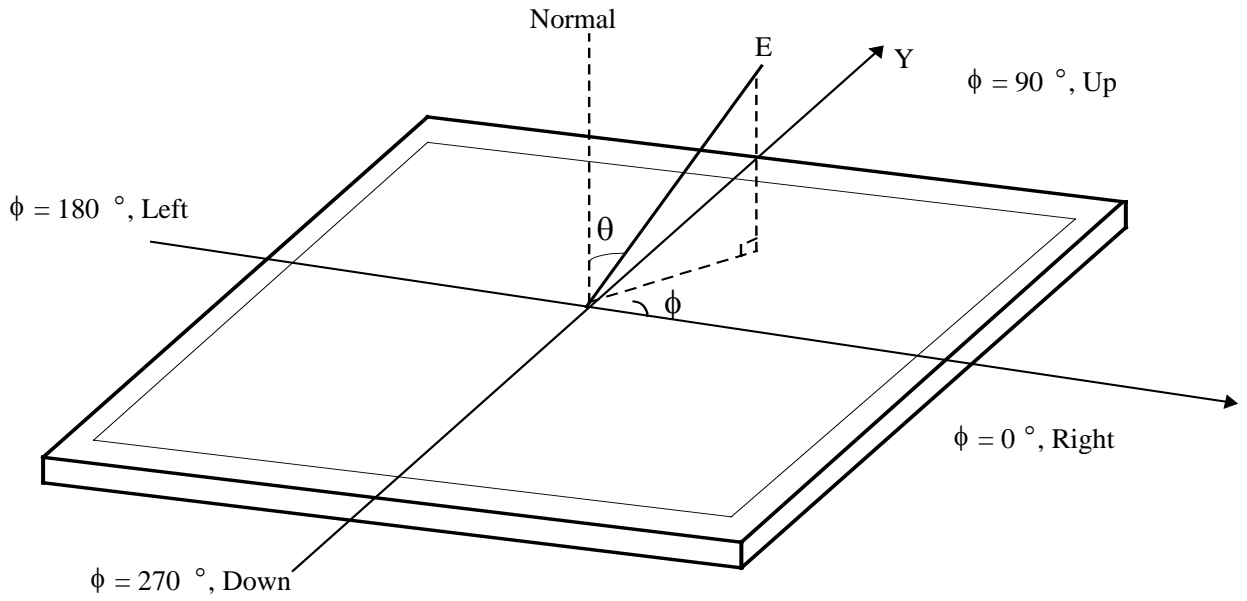

FIG. 4 Viewing angle

Product Specification

5. Mechanical Characteristics

The following items provide general mechanical characteristics. In addition the figures in the next page are detailed mechanical drawing of the LCD module.

Table 13. MECHANICAL CHARACTERISTICS

Outline Dimension	Horizontal	983.0 mm
	Vertical	576.0 mm
	Depth	51.0 mm
Bezel Area	Horizontal	939.0 mm
	Vertical	531.0 mm
Active Display Area	Horizontal	930.25 mm
	Vertical	523.01 mm
Weight	13.0Kg (Typ.) , 14.0Kg (Max.)	
Surface Treatment	Hard coating(3H) Anti-glare treatment of the front polarizer (Haze 13%)	

Note : Please refer to a mechanic drawing in terms of tolerance at the next page.

Product Specification

<FRONT VIEW>

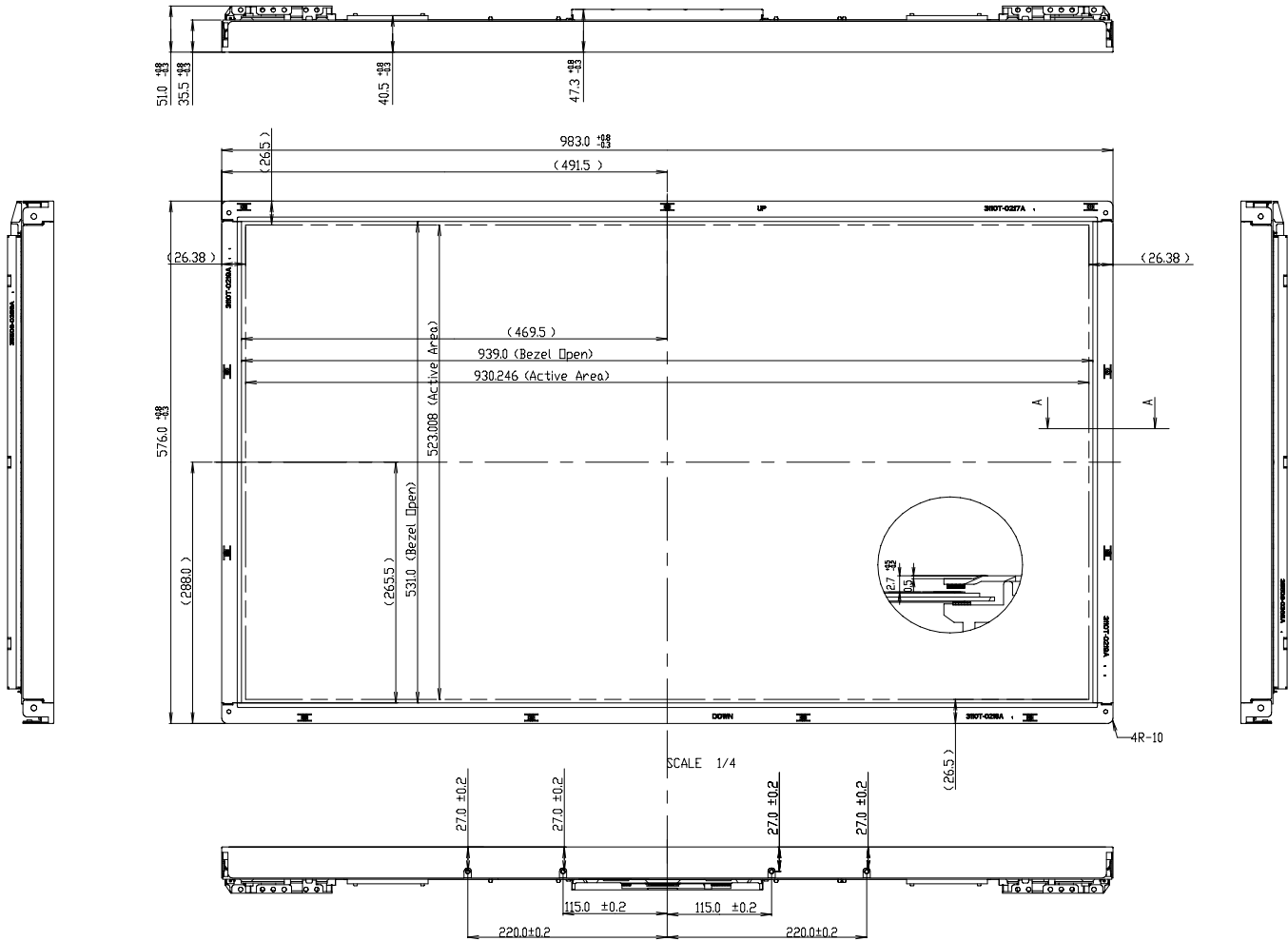

NOTE

1. Unspecified tolerance is $\pm 1.0\text{mm}$
2. Gap between top case pad and pol is $0.7^{+0.5}_{-0.2}$
3. Tilt and partial disposition tolerance of display area as follow
 - 1) Y-direction : $ABS(A-B) \times 1.5$
 - 2) X-direction : $ABS(C-D) \times 1.5$

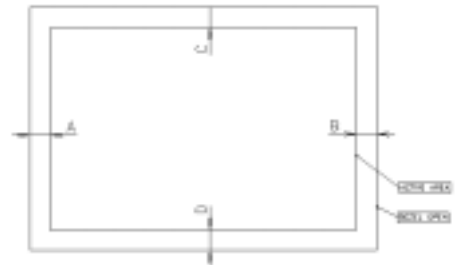

Product Specification

<REAR VIEW>

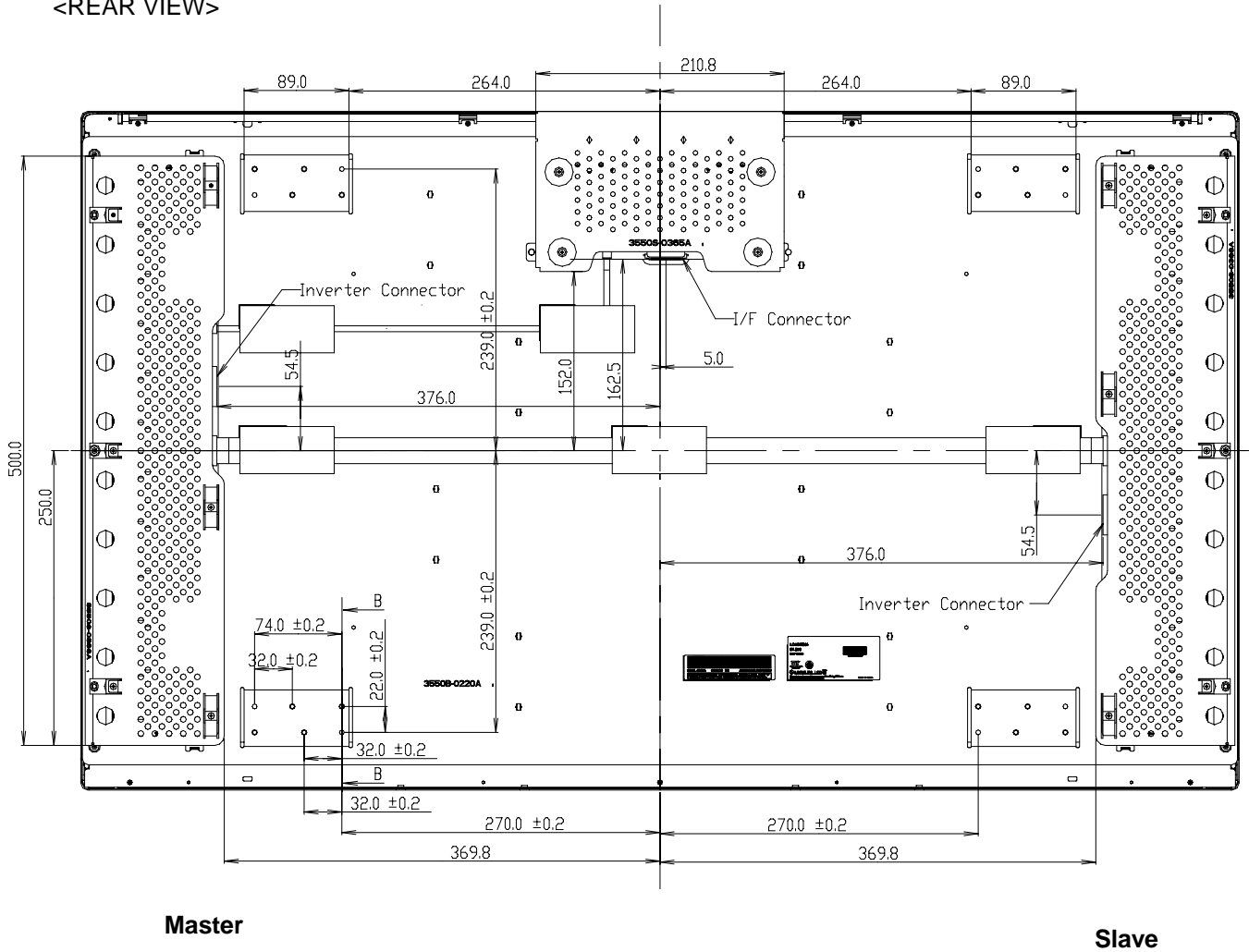

Master

Slave

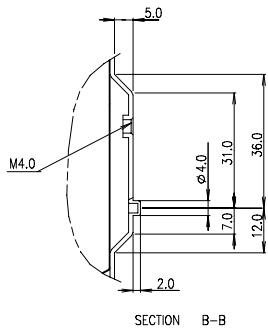

Product Specification

6. Reliability

Table 14. ENVIRONMENT TEST CONDITION

No.	Test Item	Condition
1	High temperature storage test	Ta= 50°C 240h
2	Low temperature storage test	Ta= -20°C 240h
3	High temperature operation test	Ta= 40°C 50%RH 240h
4	Low temperature operation test	Ta= 0°C 240h
5	Vibration test (operating)	Wave form : random Vibration level : 1.0G RMS Bandwidth : 10-300Hz Duration : X,Y,Z, 30 min One time each direction
6	Shock test (operating)	Shock level : 50G Waveform : half sine wave, 11ms Direction : ± X, ± Y, ± Z One time each direction
7	Humidity condition Operation	Ta= 40 °C, 90%RH
8	Altitude operating storage / shipment	0 - 14,000 feet(4267.2m) 0 - 40,000 feet(12192m)

7. International standards

7-1. Safety

- a) UL 60065, 7th Edition, dated June 30, 2003, Underwriters Laboratories, Inc., Standard for Audio, Video and Similar Electronic Apparatus.
- b) CAN/CSA C22.2, No. 60065:03, Canadian Standards Association, Standard for Audio, Video and Similar Electronic Apparatus.
- c) IEC60065:2001, 7th Edition CB-scheme and EN 60065:2002, Safety requirements for Audio, Video and Similar Electronic Apparatus..

7-2. EMC

- a) ANSI C63.4 "Methods of Measurement of Radio-Noise Emissions from Low-Voltage Electrical and Electrical Equipment in the Range of 9kHz to 40GHz. "American National Standards Institute(ANSI), 1992
- b) CISPR22 "Limits and Methods of Measurement of Radio Interface Characteristics of Information Technology Equipment." International Special Committee on Radio Interference.
- c) EN 55022 "Limits and Methods of Measurement of Radio Interface Characteristics of Information Technology Equipment." European Committee for Electrotechnical Standardization.(CENELEC), 1998 (Including A1: 2000)

Product Specification

8. Packing

8-1. Designation of Lot Mark

a) Lot Mark

A	B	C	D	E	F	G	H	I	J	K	L	M
---	---	---	---	---	---	---	---	---	---	---	---	---

A,B,C : SIZE(INCH)

E : MONTH

G ~ M : SERIAL NO.

D : YEAR

F : FACTORY CODE

Note

1. YEAR

Year	2001	2002	2003	2004	2005	2006	2007	2008	2009	2010
Mark	1	2	3	4	5	6	7	8	9	0

2. MONTH

Month	Jan	Feb	Mar	Apr	May	Jun	Jul	Aug	Sep	Oct	Nov	Dec
Mark	1	2	3	4	5	6	7	8	9	A	B	C

3. FACTORY CODE

Factory Code	Gumi	Nanjing	Paju
Mark	K	C	P

b) Location of Lot Mark

Serial No. is printed on the label. The label is attached to the backside of the LCD module.
This is subject to change without prior notice.

8-2. Packing Form

a) Package quantity in one Pallet : 12 pcs

Product Specification

9. Precautions

Please pay attention to the followings when you use this TFT LCD module.

9-1. Mounting Precautions

- (1) You must mount a module using holes arranged in four corners or four sides.
- (2) You should consider the mounting structure so that uneven force (ex. Twisted stress) is not applied to the module. And the case on which a module is mounted should have sufficient strength so that external force is not transmitted directly to the module.
- (3) Please attach the surface transparent protective plate to the surface in order to protect the polarizer. Transparent protective plate should have sufficient strength in order to resist external force.
- (4) You should adopt radiation structure to satisfy the temperature specification.
- (5) Acetic acid type and chlorine type materials for the cover case are not desirable because the former generates corrosive gas of attacking the polarizer at high temperature and the latter causes circuit break by electro-chemical reaction.
- (6) Do not touch, push or rub the exposed polarizers with glass, tweezers or anything harder than HB pencil lead. And please do not rub with dust clothes with chemical treatment. Do not touch the surface of polarizer for bare hand or greasy cloth.(Some cosmetics are detrimental to the polarizer.)
- (7) When the surface becomes dusty, please wipe gently with absorbent cotton or other soft materials like chamois soaks with petroleum benzene. Normal-hexane is recommended for cleaning the adhesives used to attach front / rear polarizers. Do not use acetone, toluene and alcohol because they cause chemical damage to the polarizer.
- (8) Wipe off saliva or water drops as soon as possible. Their long time contact with polarizer causes deformations and color fading.
- (9) Do not open the case because inside circuits do not have sufficient strength.

9-2. Operating Precautions

- (1) The spike noise causes the mis-operation of circuits. It should be lower than following voltage :
 $V = \pm 200\text{mV}$ (Over and under shoot voltage)
- (2) Response time depends on the temperature.(In lower temperature, it becomes longer.)
- (3) Brightness depends on the temperature. (In lower temperature, it becomes lower.)
And in lower temperature, response time(required time that brightness is stable after turned on) becomes longer.
- (4) Be careful for condensation at sudden temperature change. Condensation makes damage to polarizer or electrical contacted parts. And after fading condensation, smear or spot will occur.
- (5) When fixed patterns are displayed for a long time, remnant image is likely to occur.
- (6) Module has high frequency circuits. Sufficient suppression to the electromagnetic interference shall be done by system manufacturers. Grounding and shielding methods may be important to minimized the interference.
- (7) Please do not give any mechanical and/or acoustical impact to LCM. Otherwise, LCM can't be operated its full characteristics perfectly.
- (8) A screw which is fastened up the steels should be a machine screw.
(if not, it causes metallic foreign material and deal LCM a fatal blow)
- (9) Please do not set LCD on its edge.

Product Specification

9-3. Electrostatic Discharge Control

Since a module is composed of electronic circuits, it is not strong to electrostatic discharge. Make certain that treatment persons are connected to ground through wrist band etc. And don't touch interface pin directly.

9-4. Precautions for Strong Light Exposure

Strong light exposure causes degradation of polarizer and color filter.

9-5. Storage

When storing modules as spares for a long time, the following precautions are necessary.

- (1) Store them in a dark place. Do not expose the module to sunlight or fluorescent light. Keep the temperature between 5°C and 35°C at normal humidity.
- (2) The polarizer surface should not come in contact with any other object.
It is recommended that they be stored in the container in which they were shipped.

9-6. Handling Precautions for Protection Film

- (1) The protection film is attached to the bezel with a small masking tape.
When the protection film is peeled off, static electricity is generated between the film and polarizer.
This should be peeled off slowly and carefully by people who are electrically grounded and with well ion-blown equipment or in such a condition, etc.
- (2) When the module with protection film attached is stored for a long time, sometimes there remains a very small amount of glue still on the bezel after the protection film is peeled off.
- (3) You can remove the glue easily. When the glue remains on the bezel surface or its vestige is recognized, please wipe them off with absorbent cotton waste or other soft material like chamois soaked with normal-hexane.

APPENDIX- I

LC420WX4-SLB1 10bits LVDS signal Connection Example
[10bit I/F (10bit to 10bit DISM Format)]

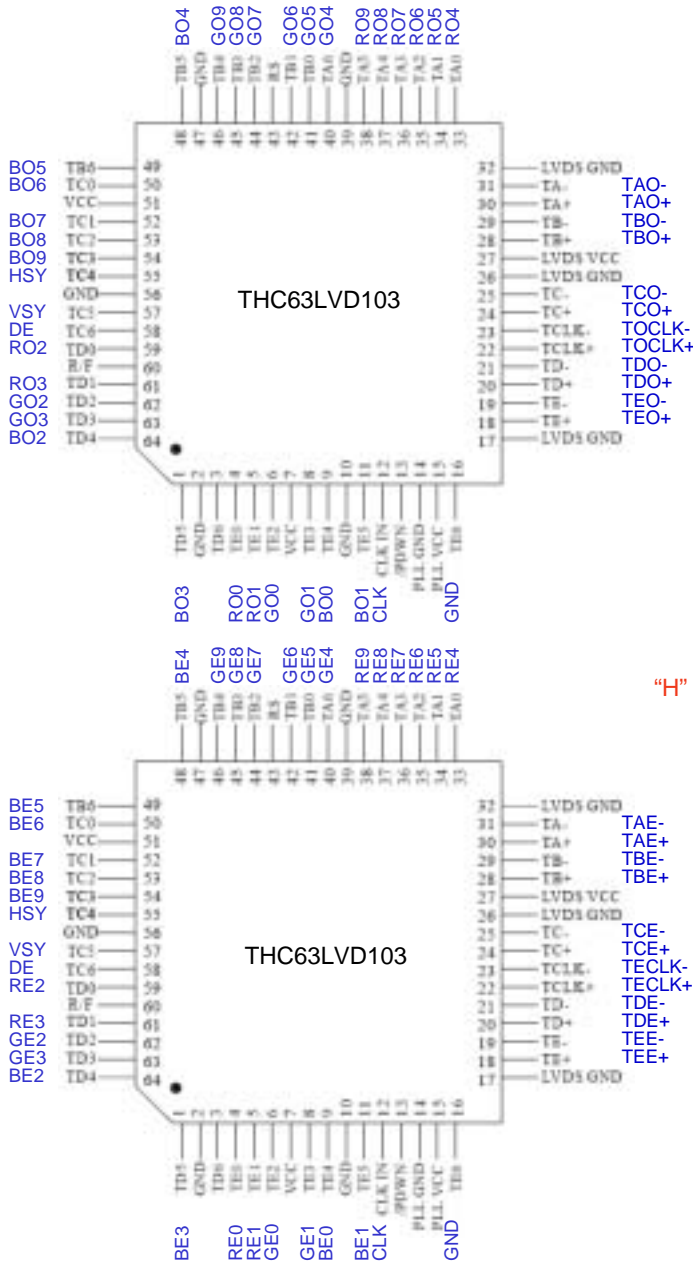

"H"

TAO-
TAO+
TBO-
TBO+
TCO-
TCO+

TOCLK-
TOCLK+

TDO-
TDO+
TEO-
TEO+

"H" or "Open"

TAE-
TAE+
TBE-
TBE+
TCE-
TCE+

TECLK-
TECLK+

TDE-
TDE+
TEE-
TEE+

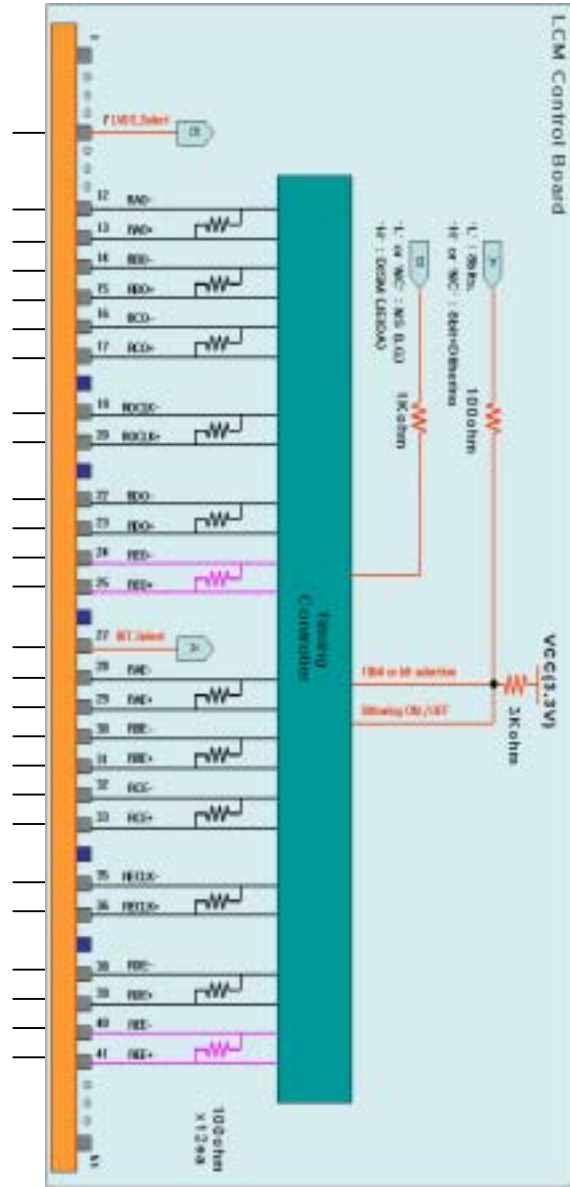

APPENDIX- II

LC420WX4-SLB1 10bits LVDS signal Connection Example
[8bit I/F (8bit to 8bit LG Format)]

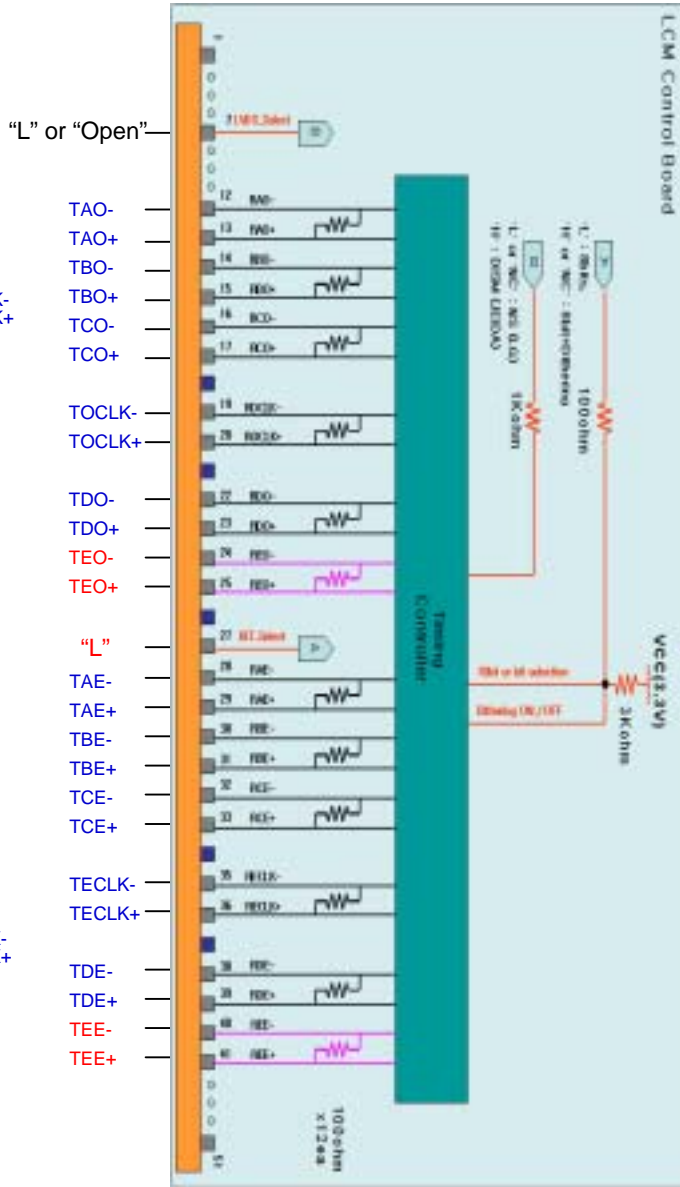
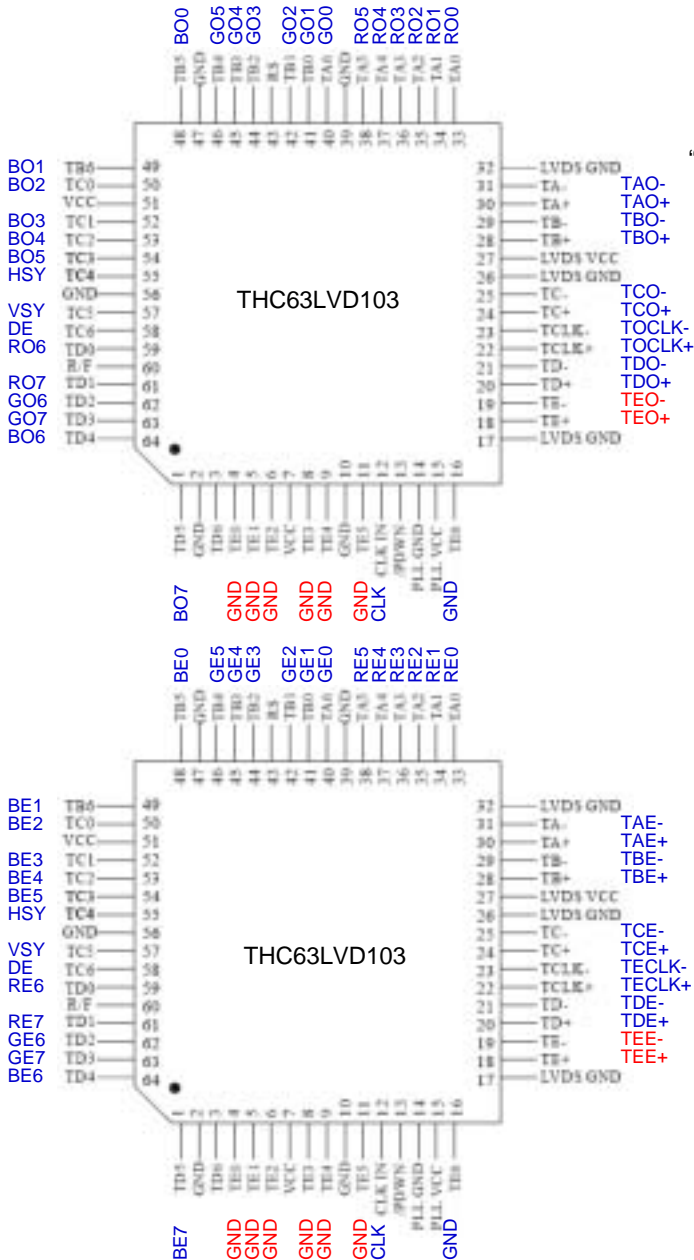

APPENDIX- III

LC420WX4-SLA1 Packing Ass'y

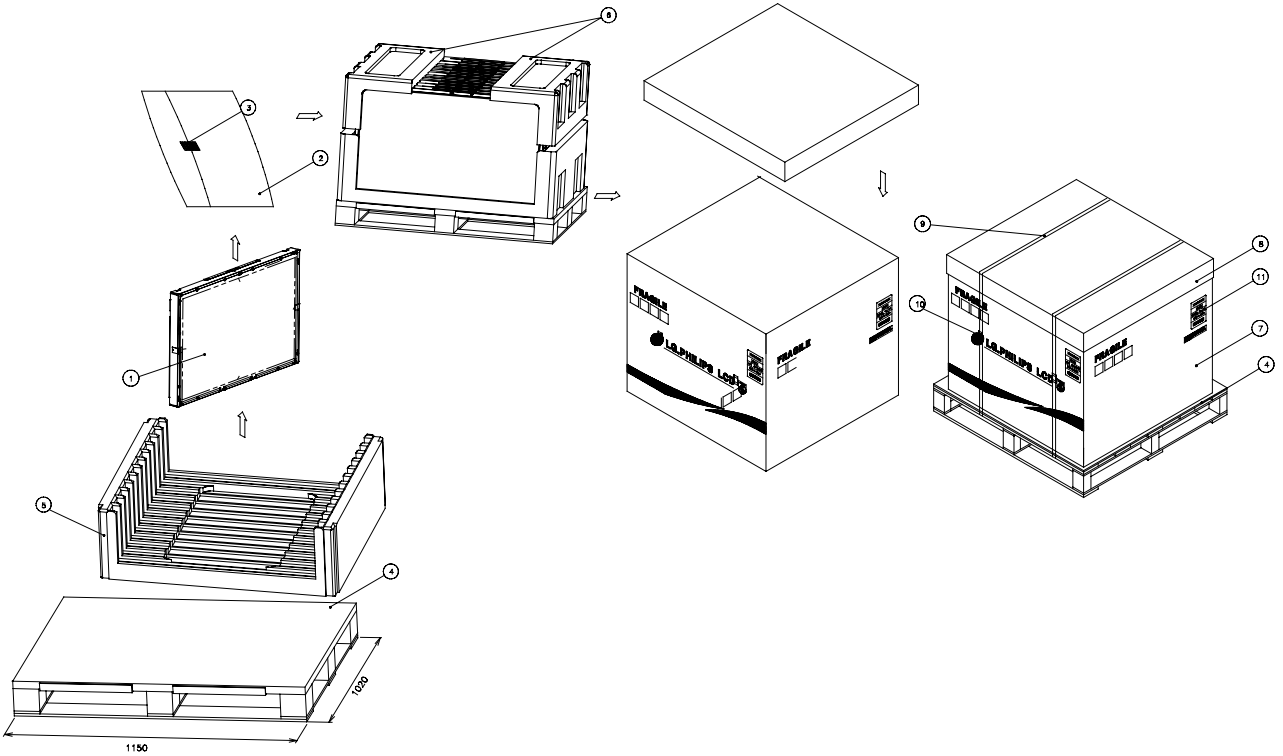

NO.	DESCRIPTION	MATERIAL
1	LCD Module	
2	BAG	42INCH
3	TAPE	MASKING 20MM X 50M
4	PALLET	PAPER 1140X1000X138MM
5	PACKING	EPS
6	PACKING	EPS
7	ANGLE PACKING	PAPER
8	PAPER ANGLE	PAPER
9	BAND	PP
10	LABEL	YUPO PAPER 80G 100x100

APPENDIX- IV

LCM Label

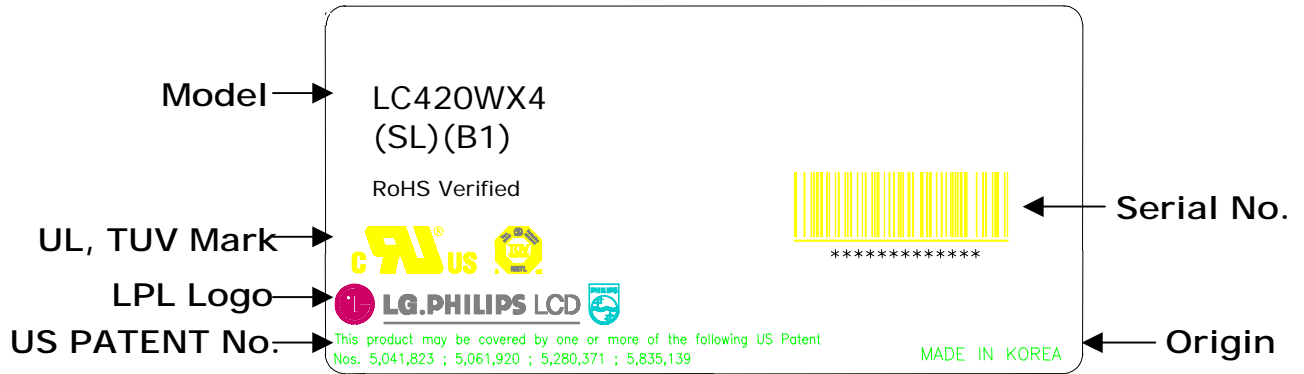

Serial No. (See CAS 25page for more information)

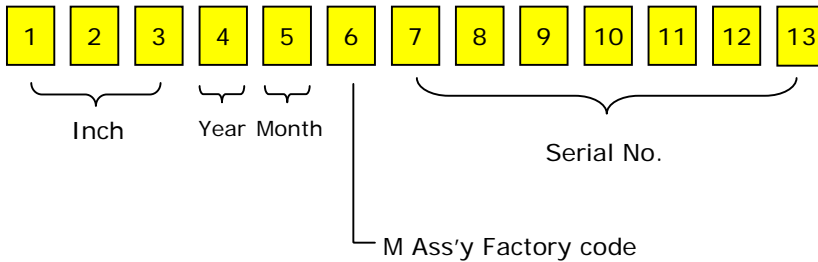

APPENDIX- V

Pallet Label

LC420WX4	
SLB1	
12 PCS	001/01-01
REMARK	
MADE IN KOREA	RoHS Verified
 ***** **	