

Product Specification

SPECIFICATION FOR APPROVAL

- () Preliminary Specification
- () Final Specification

Title	42.0" WXGA TFT LCD
--------------	---------------------------

BUYER	
MODEL	

SUPPLIER	LG.Philips LCD Co., Ltd.
*MODEL	LC420WX5
SUFFIX	SLA1 (RoHS Verified)

*When you obtain standard approval,
please use the above model name without suffix

APPROVED BY	SIGNATURE DATE
/	
/	
/	

APPROVED BY	SIGNATURE DATE
H. S Baek / G. Manager	
REVIEWED BY	
D. S Kim / Manager	
PREPARED BY	
Y. J Heo / Engineer	

Please return 1 copy for your confirmation with
your signature and comments.

**TV Products Development Dept.
LG. Philips LCD Co., Ltd**

Product Specification

CONTENTS

Number	Item	Page
	COVER	1
	CONTENTS	2
	RECORD OF REVISIONS	3
1	GENERAL DESCRIPTION	4
2	ABSOLUTE MAXIMUM RATINGS	5
3	ELECTRICAL SPECIFICATIONS	6
3-1	ELECTRICAL CHARACTERISTICS	6
3-2	INTERFACE CONNECTIONS	8
3-3	SIGNAL TIMING SPECIFICATIONS	12
3-4	SIGNAL TIMING WAVEFORMS	13
3-5	COLOR INPUT DATA REFERENCE	14
3-6	POWER SEQUENCE	15
4	OPTICAL SPECIFICATIONS	17
5	MECHANICAL CHARACTERISTICS	21
6	RELIABILITY	24
7	INTERNATIONAL STANDARDS	25
7-1	SAFETY	25
7-2	EMC	25
8	PACKING	26
8-1	DESIGNATION OF LOT MARK	26
8-2	PACKING FORM	26
9	PRECAUTIONS	27
9-1	MOUNTING PRECAUTIONS	27
9-2	OPERATING PRECAUTIONS	27
9-3	ELECTROSTATIC DISCHARGE CONTROL	28
9-4	PRECAUTIONS FOR STRONG LIGHT EXPOSURE	28
9-5	STORAGE	28
9-6	HANDLING PRECAUTIONS FOR PROTECTION FILM	28

Product Specification

1. General Description

The LC420WX5 is a Color Active Matrix Liquid Crystal Display with an integral Cold Cathode Fluorescent Lamp(CCFL) backlight system. The matrix employs a-Si Thin Film Transistor as the active element. It is a transmissive type display operating in the normally black mode. It has a 42.0 inch diagonally measured active display area with WXGA resolution (768 vertical by 1366 horizontal pixel array). Each pixel is divided into Red, Green and Blue sub-pixels or dots which are arranged in vertical stripes. Gray scale or the luminance of the sub-pixel color is determined with a 8-bit gray scale signal for each dot, thus presenting a palette of more than 16.7M(true) colors.

It has been designed to apply the 8-bit 1-port LVDS interface.

It is intended to support LCD TV, PCTV where high brightness, super wide viewing angle, high color gamut, high color depth and fast response time are important.

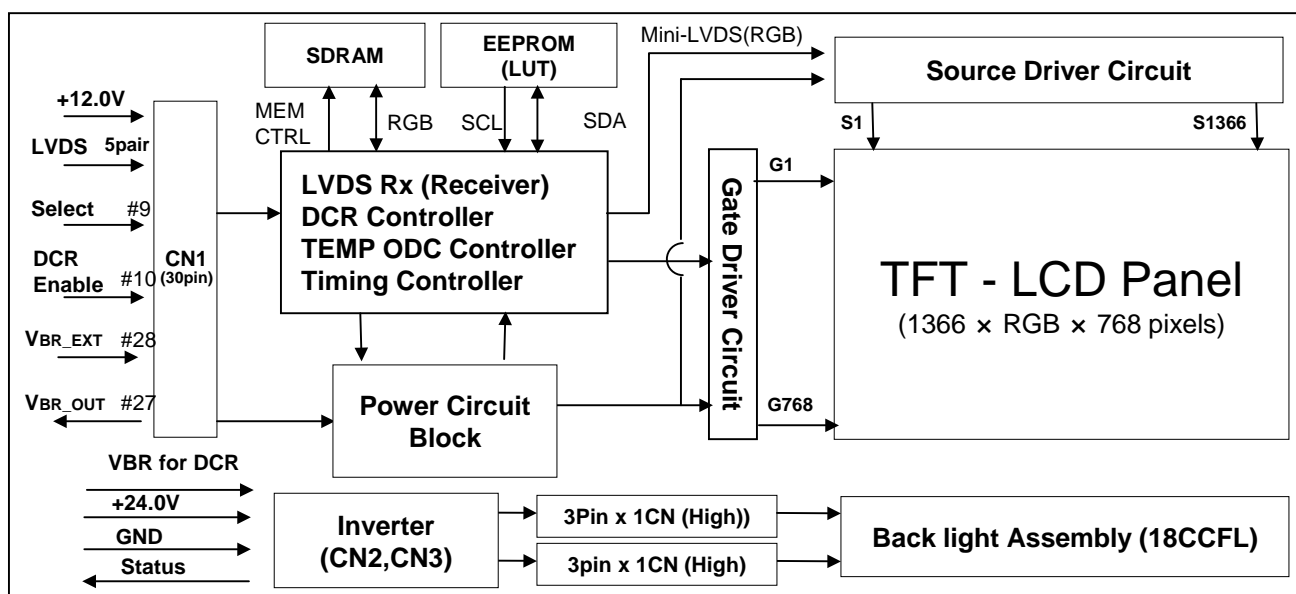

General Features

Active Screen Size	42.02 inches(1067.308mm) diagonal
Outline Dimension	983 mm(H) x 576 mm(V) x 51 mm(D) (Typ.)
Pixel Pitch	0.227mm x 0.681mm x RGB
Pixel Format	1366 horiz. by 768 vert. Pixels RGB stripe arrangement
Color Depth	8-bit, 16.7 M colors
Luminance, White	500 cd/m ² (Center 1-point) (Typ.)
Viewing Angle (CR>10)	Viewing Angle Free (R/L 178 (Typ.), U/D 178 (Typ))
Power Consumption	Total 168.36 W (Typ.) (Logic=6.36 W, Inverter=162W [I _{BL} =126mA])
Weight	11.5Kg (Typ.)
Display Operating Mode	Transmissive mode, Normally black
Surface Treatment	Hard coating(3H), Anti-glare treatment of the front polarizer

Product Specification

2. Absolute Maximum Ratings

The following items are maximum values which, if exceeded, may cause faulty operation or damage to the LCD module.

Table 1. ABSOLUTE MAXIMUM RATINGS

Parameter		Symbol	Value		Unit	Remark
			Min	Max		
Power Input Voltage	LCD circuit	V _{LCD}	-0.3	+14.0	V _{DC}	at 25 ± 2 °C
	Inverter	V _{BL}	21.6	+27.0	V _{DC}	
Inverter Control Voltage	ON/OFF	V _{OFF/VON}	-0.3	+5.25	V _{DC}	
	Brightness	V _{BR_B}	0.0	+5.0	V _{DC}	
Operating Temperature		T _{OP}	0	+50	°C	Note 1
Storage Temperature		T _{ST}	-20	+50	°C	
Operating Ambient Humidity		H _{OP}	10	90	%RH	
Storage Humidity		H _{ST}	10	90	%RH	

Note 1. Temperature and relative humidity range are shown in the figure below.

Wet bulb temperature should be 39 °C Max, and no condensation of water.

2. Gravity mura can be guaranteed under 40 °C condition.

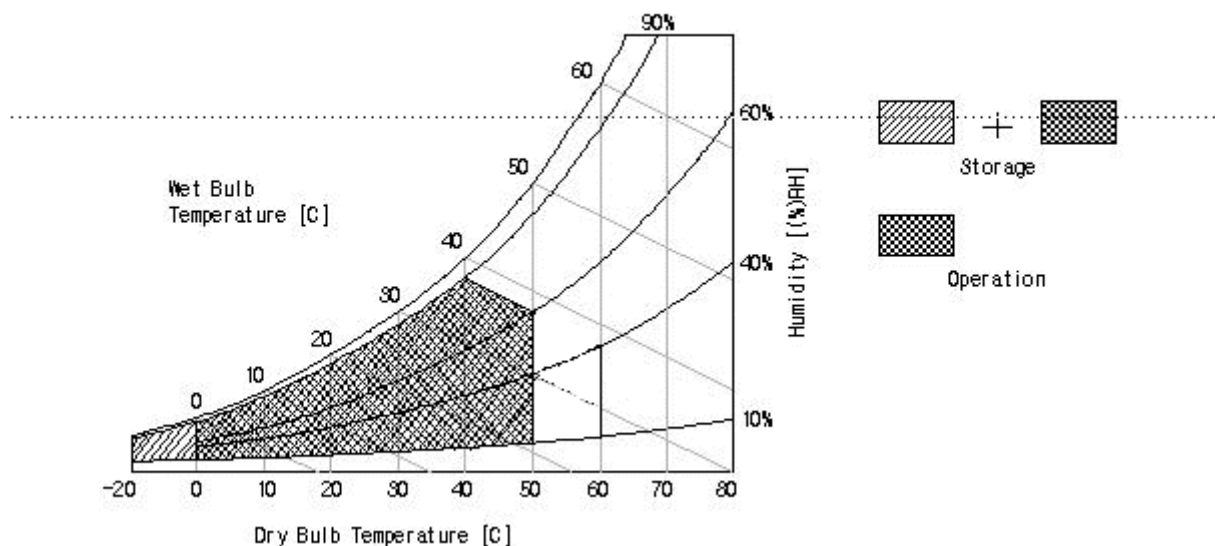

Product Specification

3. Electrical Specifications

3-1. Electrical Characteristics

It requires two power inputs. One is employed to power for the LCD circuit. The other input power for the CCFL/Backlight is to power inverter.

Table 2. ELECTRICAL CHARACTERISTICS

Parameter	Symbol	Value			Unit	Note
		Min	Typ	Max		
Circuit :						
Power Input Voltage	VLCD	11.4	12.0	12.6	VDC	
Power Input Current	ILCD	-	530	689	mA	1
		-	600	780	mA	2
Power Consumption	PLCD		6.36	8.27	Watt	1
Rush current	IRUSH	-	-	3.0	A	3

- Note :
1. The specified current and power consumption are under the $V_{LCD}=12.0V$, $25 \pm 2^{\circ}C$, $f_V=60Hz$ condition whereas mosaic pattern(8 x 6) is displayed and f_V is the frame frequency.
 2. The current is specified at the maximum current pattern.
 3. The duration of rush current is about 2ms and rising time of power input is 1ms (min.).

White : 255Gray
 Black : 0Gray

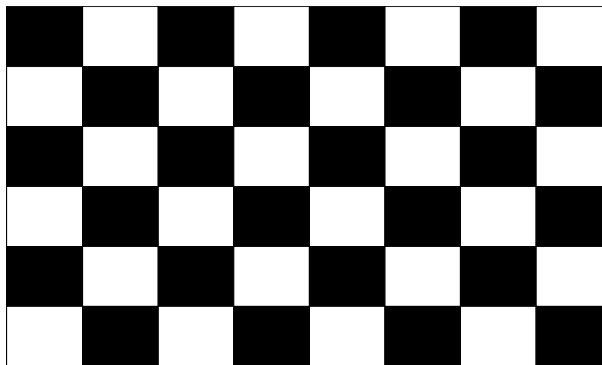

Mosaic Pattern(8 x 6)

Product Specification

Table 3. ELECTRICAL CHARACTERISTICS (Continue)

Parameter		Symbol	Values			Unit	Notes	
			Min	Typ	Max			
Inverter :								
Power Supply Input Voltage		VBL	22.8	24.0	25.2	Vdc	1	
Power Supply Input Voltage Ripple			-	-	0.4	Vp-p	1	
Power Supply Input Current	After Aging	IBL_A	-	6.75	7.2	A	$V_{BR-A} = 1.65V \dots 1$	
			-	7.25	7.7	A	$V_{BR-A} = 3.3V \dots 1$	
	Before Aging	IBL_B	-	8.1	8.6	A	$V_{BR-A} = 1.65V \dots 2$	
			-	8.5	9.0	A	$V_{BR-A} = 3.3V \dots 2$	
Power Supply Input Current (In-Rush)		Irush	-	-	8.6	A	$V_{BL} = 24V$ $V_{BR-B} = 3.3V$ $V_{BR-A} = 1.65V$	
Power Consumption		PBL	-	162	172.8	W	$V_{BR-A} = 1.65V \dots 1$	
Input Voltage for Control System Signals	Brightness Adjust		V_{BR-A}	0.0	1.65	3.3	Vdc	
	On/Off	On	V on	2.5	-	5.0	Vdc	
		Off	V off	-0.3	0.0	0.8	Vdc	
	Brightness Adjust		V_{BR-B}	0	-	3.3	V	3
Lamp:								
Discharge Stabilization Time		T_s			3	min	4	
Life Time			50,000			Hrs	5	

Notes :

- Electrical characteristics are determined after the unit has been 'ON' and stable for approximately 120 minutes at $25 \pm 2^\circ\text{C}$. The specified current and power consumption are under the typical supply Input voltage 24V, it is total power consumption.
The ripple voltage of the power supply input voltage is under 0.4 Vp-p. LPL recommend Input Voltage is $24.0V \pm 5\%$.
- Electrical characteristics are determined within 30 minutes at $25 \pm 2^\circ\text{C}$.
The specified currents are under the typical supply Input voltage 24V.
- Brightness Control.
This V_{BR-B} Voltage control brightness.

V_{BR-B} Voltage	Function	V_{BR-B} Voltage	Function
0V	Minimum Duty (25%)	3.3V	Maximum Duty (100%)

- The brightness of the lamp after lighted for 5minutes is defined as 100%.
 T_s is the time required for the brightness of the center of the lamp to be not less than 95% at typical current.
The screen of LCD module may be partially dark by the time the brightness of lamp is stable after turn on.
- Specified Values are for a single lamp which is aligned horizontally.
The life time is determined as the time which luminance of the lamp is 50% compared to that of initial value at the typical/maximum lamp current ($V_{BR-A}=1.65V/3.3V$) on condition of continuous operating at $25 \pm 2^\circ\text{C}$
- The duration of rush current is about 15ms.

Product Specification

3-2. Interface Connections

This LCD module employs two kinds of interface connection, a 30-pin connector is used for the module electronics and Master 14-pin and Slave 12-pin connectors are used for the integral backlight system.

3-2-1. LCD Module

- LCD Connector(CN1) : FI-X30SSL-HF (Manufactured by JAE) or Equivalent
- Mating Connector : FI-30C2L (Manufactured by JAE) or Equivalent

Table 4. MODULE CONNECTOR(CN1) PIN CONFIGURATION

Pin No.	Symbol	Description	Note
1	VLCD	Power Supply +12.0V	
2	VLCD	Power Supply +12.0V	
3	VLCD	Power Supply +12.0V	
4	VLCD	Power Supply +12.0V	
5	GND	Ground	
6	GND	Ground	
7	GND	Ground	
8	GND	Ground	
9	Select	Select LVDS Data format	1
10	DCR Enable	Dynamic CR Enable ('L' = Disable , 'H' = Enable)	2
11	GND	Ground	
12	RA-	LVDS Receiver Signal(-)	
13	RA+	LVDS Receiver Signal(+)	
14	GND	Ground	
15	RB-	LVDS Receiver Signal(-)	
16	RB+	LVDS Receiver Signal(+)	
17	GND	Ground	
18	RC-	LVDS Receiver Signal(-)	
19	RC+	LVDS Receiver Signal(+)	
20	GND	Ground	
21	RCLK-	LVDS Receiver Clock Signal(-)	
22	RCLK+	LVDS Receiver Clock Signal(+)	
23	GND	Ground	
24	RD-	LVDS Receiver Signal(-)	
25	RD+	LVDS Receiver Signal(+)	
26	GND	Ground	
27	VBR_OUT	VBR output form LCD module	
28	VBR_EXT	External VBR input from System to LCD module	
29	GND	Ground	
30	GND	Ground	3

Note: 1. The pin no 9 is an option pin for DISM or LG format. (LG Format = "GND" / DISM Format ="VCC")

Please refer to page 9 and 10 for further details

2. The pin no 10 is an option pin for DCR Function (Enable = "VCC" / Disable ="GND")

3. The pin no 30 is LCD Test option.

LCM operates "AGP" (Auto Generation Pattern) or "NSB" (No Signal Black) is case that LVDS signals are out of frequency or abnormal condition in spite of 12 volt power supply.

LPL recommends "NSB". (AGP : "VCC" or "OPEN" / NSB : "GND")

4. All GND (ground) pins should be connected together, which should be also connected to the LCD module's metal frame.

5. All VLCD (power input) pins should be connected together.

6. Input Levels of LVDS signals are based on the IEA 664 Standard.

Product Specification

Table 5. REQUIRED SIGNAL ASSIGNMENT FOR LVDS TRANSMITTER (Pin9="L")

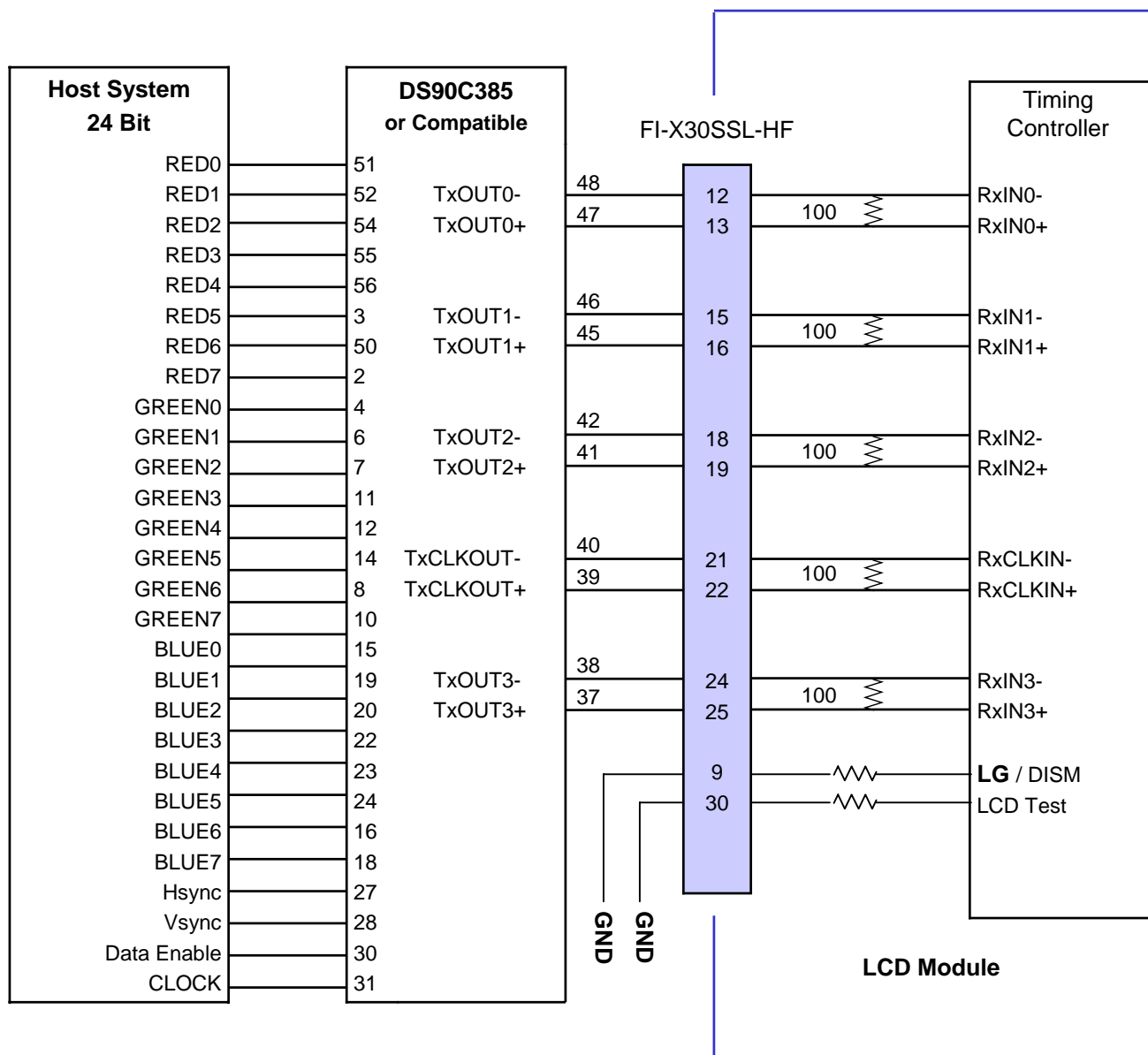

- Note: 1. The LCD Module uses a 100 Ohm[] resistor between positive and negative lines of each receiver input.
 2. Refer to LVDS Transmitter Data Sheet for detail descriptions. (DS90C385 or Compatible)
 3. '7' means MSB and '0' means LSB at R,G,B pixel data.

Product Specification

Table 6. REQUIRED SIGNAL ASSIGNMENT FOR LVDS TRANSMITTER (Pin9="H")

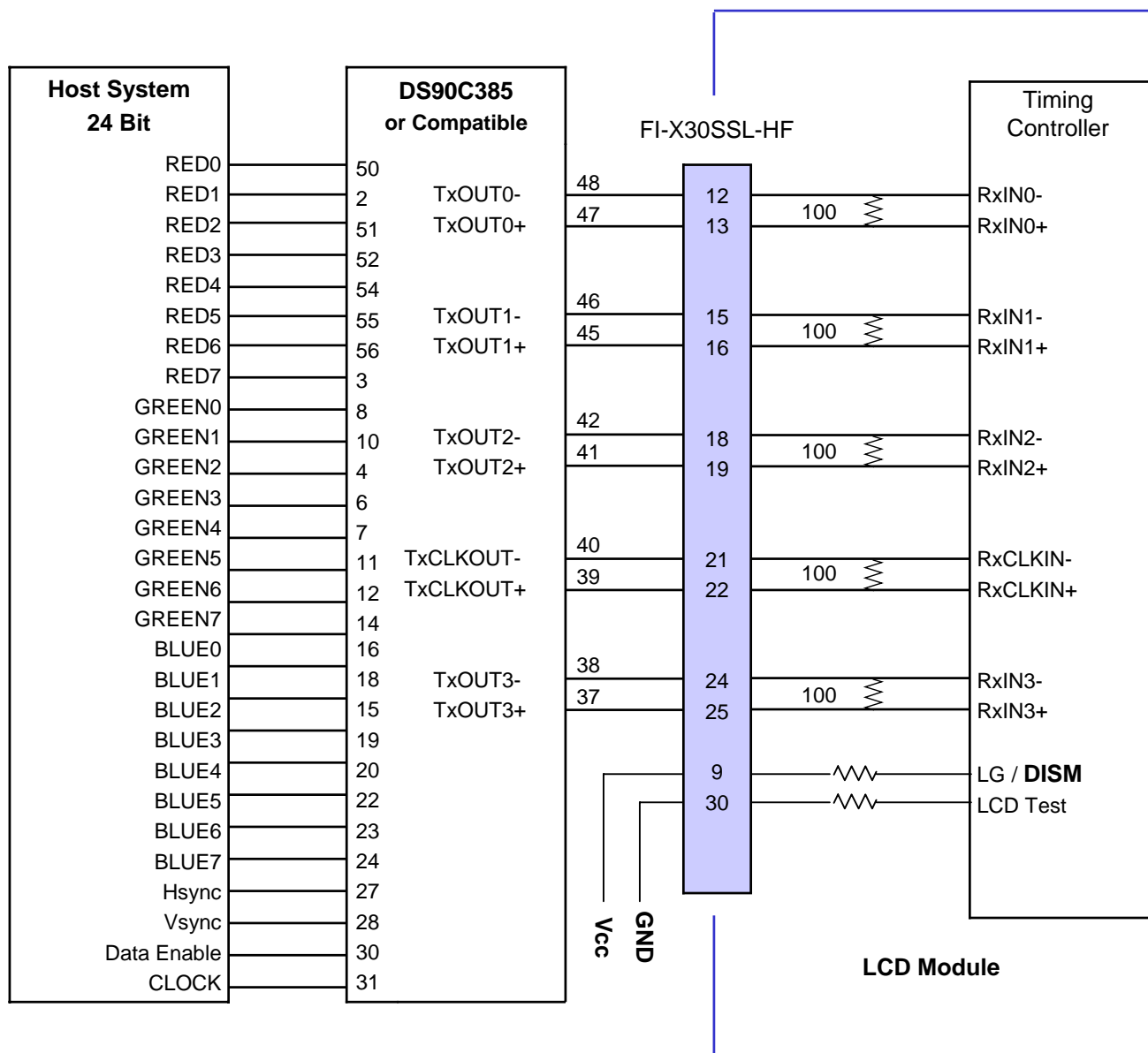

- Note: 1. The LCD module uses a 100 Ohm[] resistor between positive and negative lines of each receiver input.
 2. Refer to LVDS Transmitter Data Sheet for detail descriptions. (DS90C385 or Compatible)
 3. '7' means MSB and '0' means LSB at R,G,B pixel data.

Product Specification

3-2-2. Backlight Inverter

Master

- Inverter Connector : S14B-PH-SMC
(manufactured by JST) or Equivalent
- Mating Connector : PHR-14 or Equivalent

Slave

- Inverter Connector : S12B-PH-SMC
(manufactured by JST) or Equivalent
- Mating Connector : PHR-12 or Equivalent

Table 7. INVERTER CONNECTOR PIN CONFIGURATION

Pin No	Symbol	Description	Master	Slave	Note
1	VBL	Power Supply +24.0V	VBL	VBL	
2	VBL	Power Supply +24.0V	VBL	VBL	
3	VBL	Power Supply +24.0V	VBL	VBL	
4	VBL	Power Supply +24.0V	VBL	VBL	
5	VBL	Power Supply +24.0V	VBL	VBL	
6	GND	Backlight Ground	GND	GND	
7	GND	Backlight Ground	GND	GND	
8	GND	Backlight Ground	GND	GND	1
9	GND	Backlight Ground	GND	GND	
10	GND	Backlight Ground	GND	GND	
11	VBR-A	Analog dimming DC 0.0V ~ 3.3V	VBR-A	Don't care	2, 3
12	VON/OFF	0.0V ~ 5.0V	On/Off	Don't care	Open/High for B/L on as default
13	VBR-B	Burst dimming DC 0.0V ~ 3.3V	VBR-B	-	3
14	Status	Normal : Upper 3.0V Abnormal : Under 0.7V	Status	-	4

Note : 1. GND should be connected to the LCD module's metal frame.

2. If Pin #11 is open, VBR-A = 1.65V

When apply over 1.65V (~ 3.3V), its luminance is increasing however lamp's life time is decreasing.

It could be usable for boost up luminance when using DCR (=Dynamic contrast ratio) function only.

3. Minimum Brightness : VBR = 0V Maximum Brightness : VBR = 3.3V

4. Even though Pin #14 is open, there is no effect on inverter operating, The output terminal of inverter

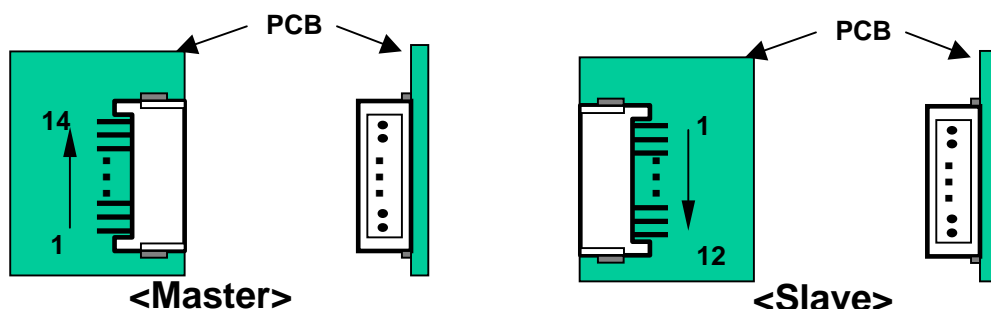
Rear view of LCM

Product Specification

3-3. Signal Timing Specifications

Table 8 shows the signal timing required at the input of the LVDS transmitter. All of the interface signal timing should be satisfied with the following specification for normal operation.

Table 8. TIMING TABLE for NTSC &PAL
[DE (Data Enable) Only]

ITEM	Symbol		Min	Typ	Max	Unit	Note
DCLK	Period	tCLK	12.2	13.8	14.7	ns	
	Frequency	-	68	72.4	80	MHz	
Hsync	Period	tHP	1456	1528	1776	tCLK	
	Horizontal Valid	tHV	1366	1366	1366	tCLK	
	Horizontal Blank	-	tHP- tHV	162	tHP- tHV		
	Frequency	fH	45	47.4	50	KHz	
	Width	tWH	-	32	-	tCLK	
	Horizontal Back Porch	tHBP	24	48	-		
	Horizontal Front Porch	tHFP	40	80	-		
Vsync	Period	tVP	776	790	1063	tHP	Note 1) PAL : 47~53Hz NTSC : 57~63Hz
	Vertical Valid	tVV	768	768	768	tHP	
	Vertical Blank	-	tVP- tVV	22	tVP- tVV	tHP	
	Frequency	fV	47	60	63	Hz	
	Width	tWV	-	5	-	tHP	
	Vertical Back Porch	tVBP	5	15	-	Hz	
	Vertical Front Porch	tVFP	1	2	-	tHP	

Note :

1. The performance of the electro-optical characteristics may be influenced by variance of the vertical refresh rate.
2. Above Timing Tables are only valid for DE Mode.

Product Specification

3-4. Signal Timing Waveforms

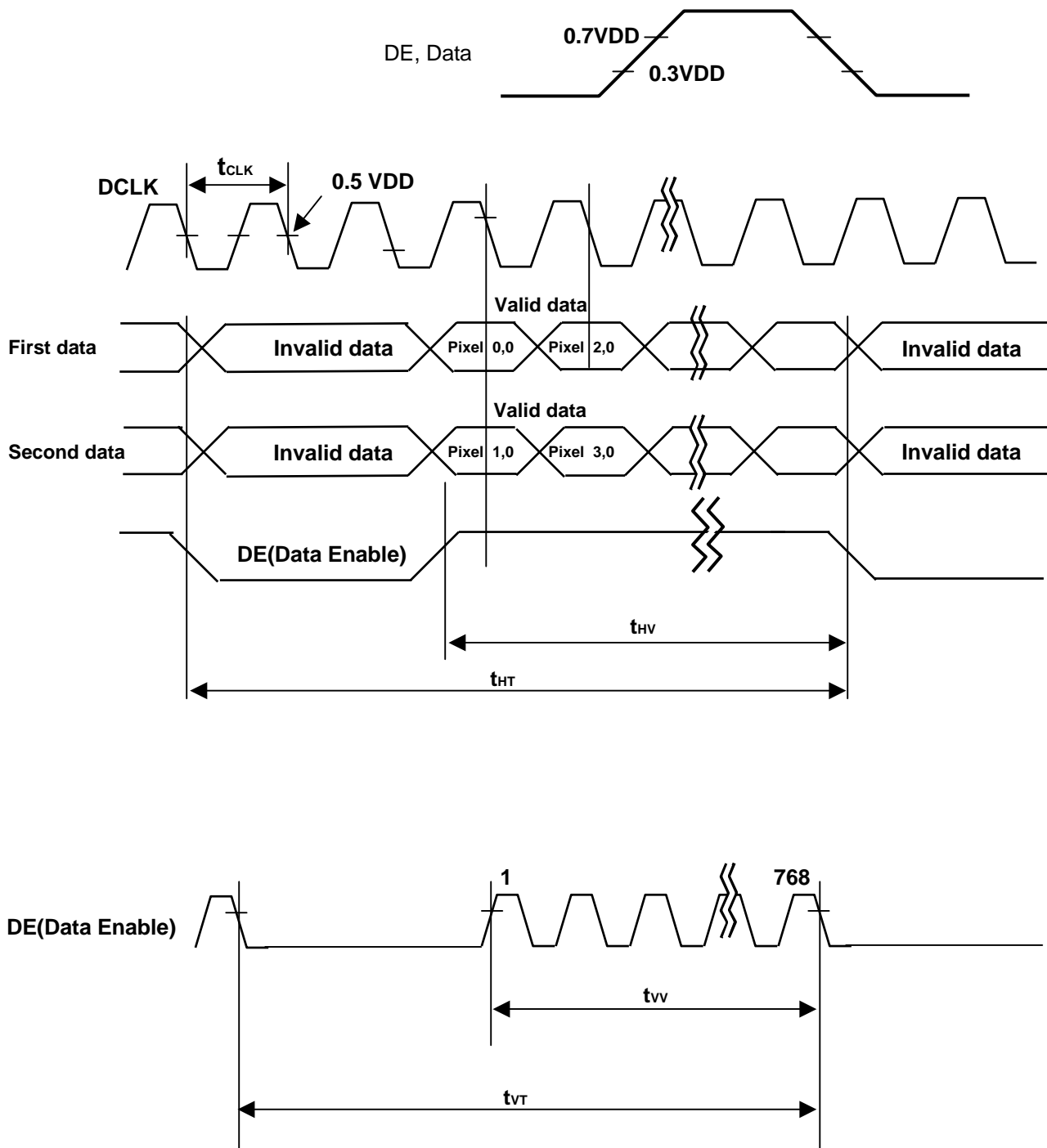

Product Specification

3-5. Color Data Reference

The brightness of each primary color(red,green,blue) is based on the 8-bit gray scale data input for the color. The higher binary input, the brighter the color. Table 10 provides a reference for color versus data input.

Table 9. COLOR DATA REFERENCE

Color		Input Color Data																							
		RED								GREEN								BLUE							
		MSB	LSB	MSB	LSB	MSB	LSB	MSB	LSB	MSB	LSB	MSB	LSB	MSB	LSB	MSB	LSB								
R7	R6	R5	R4	R3	R2	R1	R0	G7	G6	G5	G4	G3	G2	G1	G0	B7	B6	B5	B4	B3	B2	B1	B0		
Basic Color	Black	0	0	0	0	0	0	0	0	0	0	0	0	0	0	0	0	0	0	0	0	0	0	0	0
	Red (255)	1	1	1	1	1	1	1	1	0	0	0	0	0	0	0	0	0	0	0	0	0	0	0	0
	Green (255)	0	0	0	0	0	0	0	0	1	1	1	1	1	1	1	1	0	0	0	0	0	0	0	0
	Blue (255)	0	0	0	0	0	0	0	0	0	0	0	0	0	0	0	0	1	1	1	1	1	1	1	1
	Cyan	0	0	0	0	0	0	0	0	1	1	1	1	1	1	1	1	1	1	1	1	1	1	1	1
	Magenta	1	1	1	1	1	1	1	1	0	0	0	0	0	0	0	0	1	1	1	1	1	1	1	1
	Yellow	1	1	1	1	1	1	1	1	1	1	1	1	1	1	1	1	0	0	0	0	0	0	0	0
	White	1	1	1	1	1	1	1	1	1	1	1	1	1	1	1	1	1	1	1	1	1	1	1	1
RED	RED (000) Dark	0	0	0	0	0	0	0	0	0	0	0	0	0	0	0	0	0	0	0	0	0	0	0	0
	RED (001)	0	0	0	0	0	0	0	1	0	0	0	0	0	0	0	0	0	0	0	0	0	0	0	0
							
	RED (254)	1	1	1	1	1	1	1	0	0	0	0	0	0	0	0	0	0	0	0	0	0	0	0	0
	RED (255)	1	1	1	1	1	1	1	1	0	0	0	0	0	0	0	0	0	0	0	0	0	0	0	0
GREEN	GREEN (000) Dark	0	0	0	0	0	0	0	0	0	0	0	0	0	0	0	0	0	0	0	0	0	0	0	0
	GREEN (001)	0	0	0	0	0	0	0	0	0	0	0	0	0	0	0	1	0	0	0	0	0	0	0	0
							
	GREEN (254)	0	0	0	0	0	0	0	0	1	1	1	1	1	1	1	0	0	0	0	0	0	0	0	0
	GREEN (255)	0	0	0	0	0	0	0	0	1	1	1	1	1	1	1	1	0	0	0	0	0	0	0	0
BLUE	BLUE (000) Dark	0	0	0	0	0	0	0	0	0	0	0	0	0	0	0	0	0	0	0	0	0	0	0	0
	BLUE (001)	0	0	0	0	0	0	0	0	0	0	0	0	0	0	0	0	0	0	0	0	0	0	0	1
							
	BLUE (254)	0	0	0	0	0	0	0	0	0	0	0	0	0	0	0	0	1	1	1	1	1	1	1	0
	BLUE (255)	0	0	0	0	0	0	0	0	0	0	0	0	0	0	0	0	1	1	1	1	1	1	1	1

Product Specification

3-6. Power Sequence

3-6-1. LCD Driving circuit

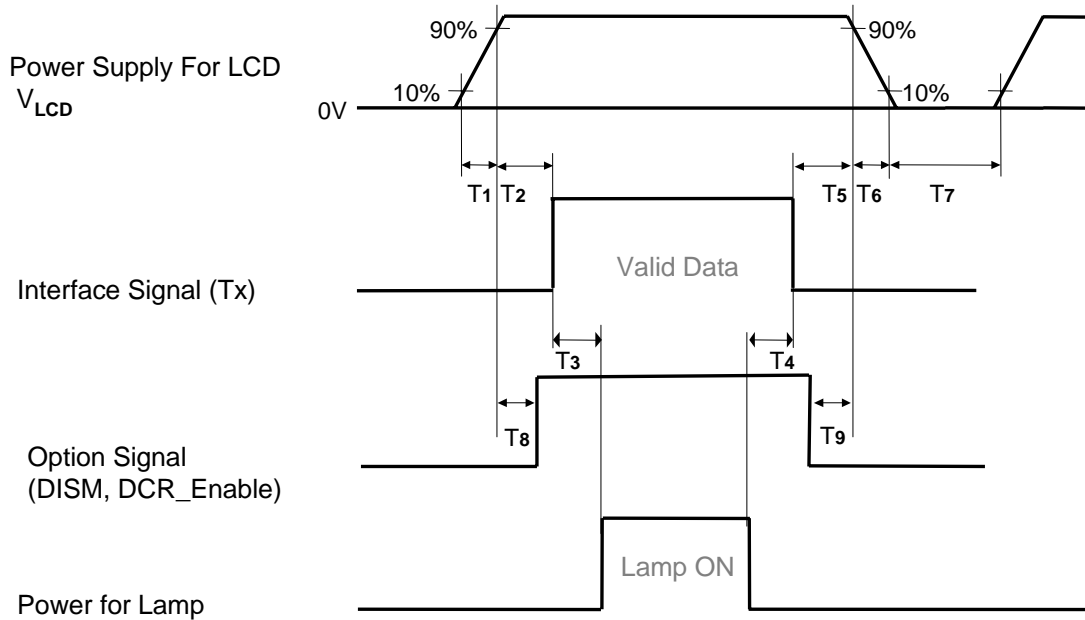
Table 10. POWER SEQUENCE

Parameter	Value			Unit
	Min	Typ	Max	
T1	1.0	-	20	ms
T2	5.0	-	50	ms
T3	200	-	-	ms
T4	200	-	-	ms
T5	0.5	-	50	ms
T6	-	-	300	ms
T7	1.0	-	-	s
T8	0 < T8 < T2			ms
T9	0 < T9 < T5			ms

- Note :
1. Please avoid floating state of interface signal at invalid period.
 2. When the interface signal is invalid, be sure to pull down the power supply V_{LCD} to 0V.
 3. The case when the T2/T5 exceed maximum specification, it operates protection pattern(Black pattern) till valid signal inputted. There is no reliability problem.
 4. The T3/T4 is recommended value, the case when failed to meet a minimum specification, abnormal display would be shown. There is no reliability problem.

Product Specification

3-6-2. Sequence for Inverter

Power Supply For Inverter

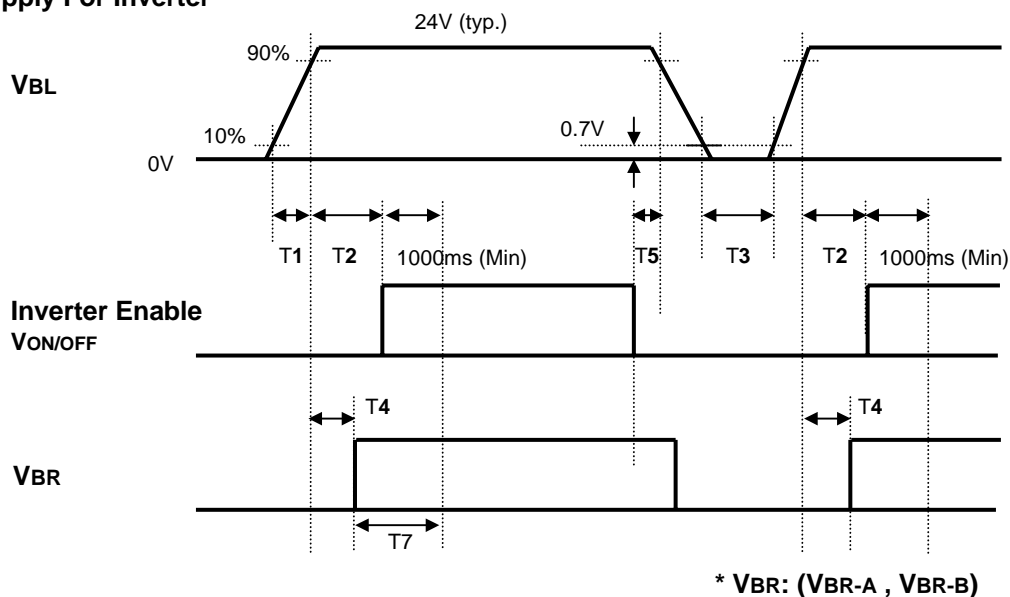

3-6-3. Deep condition for Inverter

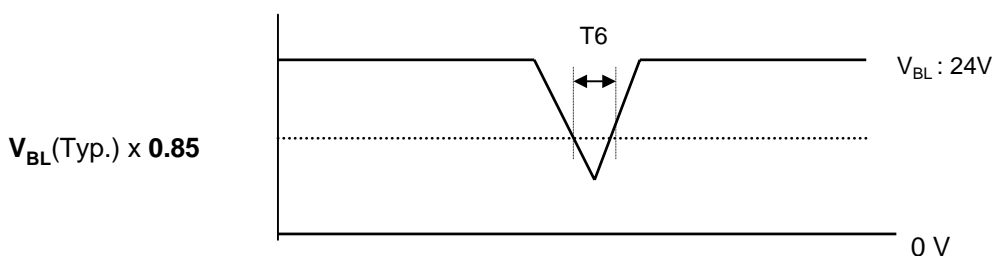

Table 11. Power Sequence for Inverter

Parameter	Values			Units	Remarks
	Min	Typ	Max		
T1	20	-	-	ms	1
T2	500	-	-	ms	
T3	200	-	-	ms	
T4	0	-	-	ms	2
T5	10	-	-	ms	
T6	-	-	10	ms	$V_{BL}(Typ.) \times 0.85$
T7	1000	-	-	ms	3

Notes : 1. T1 describes rising time of 0V to 24V and is not applied at restarting time.

2. T4(max) is less than T2.

3. In T7 section, VBR-B is 3.3V and VBR-A is 1.65V

Product Specification

4. Optical Specification

Optical characteristics are determined after the unit has been 'ON' and stable in a dark environment at $25 \pm 2^\circ\text{C}$. The values are specified at an approximate distance 50cm from the LCD surface at a viewing angle of Φ and θ equal to 0° .

It is presented additional information concerning the measurement equipment and method in FIG. 1.

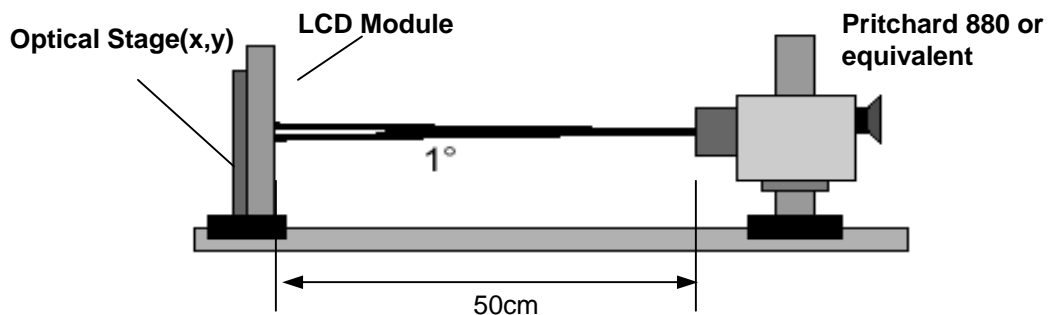

FIG. 1 Optical Characteristic Measurement Equipment and Method

Table 12. OPTICAL CHARACTERISTICS

$T_a = 25 \pm 2^\circ\text{C}$, $V_{\text{LCD}} = 12.0\text{V}$, $f_v = 60\text{Hz}$, $D_{\text{clk}} = 72.4\text{MHz}$, $V_{\text{BR-A}} = 3.3\text{V}$, $V_{\text{BR-B}} = 3.3\text{V}$

Parameter	Symbol	Value			Unit	Note	
		Min	Typ	Max			
Contrast Ratio	CR	700	1000			1	
	CR with DCR	1400	2000				
Surface Luminance, white	L_{WH}	400	500		cd/m^2	2	
Luminance Variation	δ_{WHITE} 5P			1.3		3	
Response Time	Gray-to-Gray	G to G	-	5	8	ms	4
	Rise + decay	$T_{\text{R}} + T_{\text{D}}$	-	10	14		
Color Coordinates [CIE1931]	RED	Rx	Typ -0.03	0.635	Typ +0.03		
		Ry		0.344			
	GREEN	Gx		0.286			
		Gy		0.614			
	BLUE	Bx		0.146			
		By		0.061			
	WHITE	Wx		0.279			
		Wy		0.292			
Viewing Angle (CR>10)							
	x axis, right ($\phi=0^\circ$)	θ_r	85	89	-	degree	5
	x axis, left ($\phi=180^\circ$)	θ_l	85	89	-		
	y axis, up ($\phi=90^\circ$)	θ_u	85	89	-		
	y axis, down ($\phi=270^\circ$)	θ_d	85	89	-		
Gray Scale			-		-		6

Product Specification

Note :1. Contrast Ratio(CR) is defined mathematically as :

CR(Contrast Ratio) = Maximum CR_n (n=1, 2, 3, 4, 5)

DCR(Dynamic CR) = Maximum CR_n (n=1, 2, 3, 4, 5)

$$CR_n = \frac{\text{Surface Luminance at position n with all white pixels}}{\text{Surface Luminance at position n with all black pixels}}$$

n = the Position number(1, 2, 3, 4, 5). For more information, see FIG 2.

2. Surface luminance are determined after the unit has been 'ON' and 30min after lighting the backlight in a dark environment at $25 \pm 2^\circ\text{C}$. Surface luminance is the luminance value at center 1-point across the LCD surface 50cm from the surface with all pixels displaying white.

For more information see the FIG. 2.

3. The variation in surface luminance , δ WHITE is defined as :

$$\delta \text{ WHITE}(5P) = \text{Maximum}(L_{on1}, L_{on2}, L_{on3}, L_{on4}, L_{on5}) / \text{Minimum}(L_{on1}, L_{on2}, L_{on3}, L_{on4}, L_{on5})$$

Where L_{on1} to L_{on5} are the luminance with all pixels displaying white at 5 locations .

For more information, see the FIG. 2.

4. Response time is the time required for the display to transition from G(N) to G(M) (Rise Time, Tr_R) and from G(M) to G(N) (Decay Time, Tr_D). For additional information see the FIG. 3. (N<M)

5. Viewing angle is the angle at which the contrast ratio is greater than 10. The angles are determined for the horizontal or x axis and the vertical or y axis with respect to the z axis which is normal to the LCD module surface. For more information, see the FIG. 4.

6. Gray scale specification

Gamma Value is approximately 2.2. For more information, see the Table 13.

Table 13. GRAY SCALE SPECIFICATION

Gray Level	Luminance [%] (Typ)	Luminance [%] (Typ) with DCR
L0	0.11	0.06
L15	0.19	0.16
L31	1.08	0.63
L47	2.07	1.68
L63	4.51	3.54
L79	7.75	6.41
L95	12.05	10.82
L111	17.06	16.74
L127	22.36	22.00
L143	28.21	27.44
L159	35.56	34.62
L175	43.96	42.94
L191	53.00	51.94
L207	63.37	62.25
L223	74.66	73.66
L239	88.17	87.05
L255	100	100

Product Specification

Measuring point for surface luminance & measuring point for luminance variation

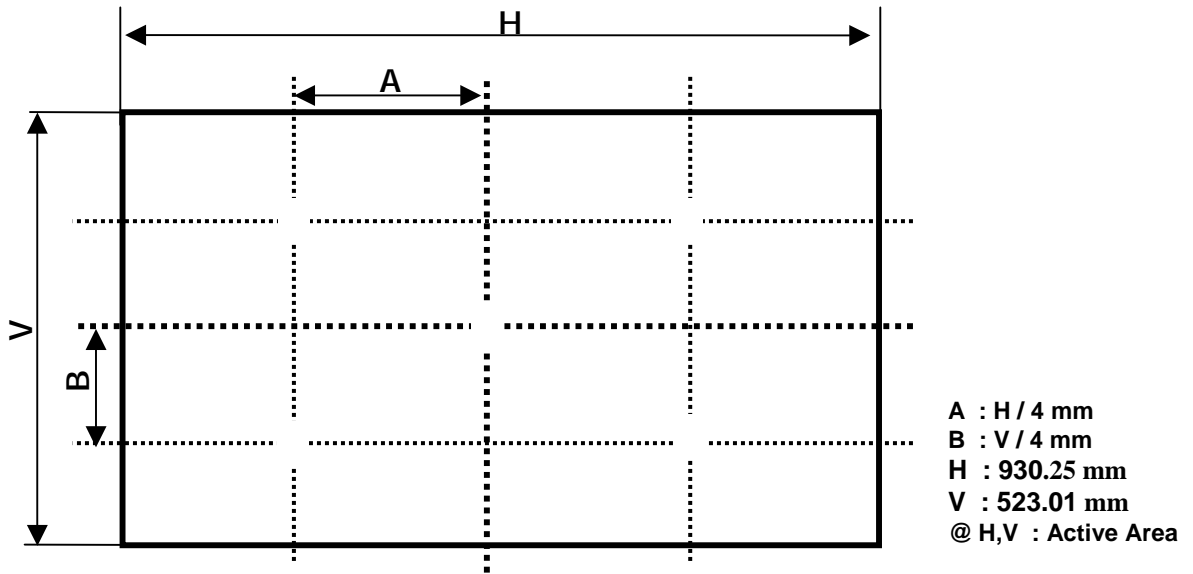

FIG.2 Measure Point for Luminance

Response time is defined as the following figure and shall be measured by switching the input signal for "Gray(N)" and "Gray(M)".

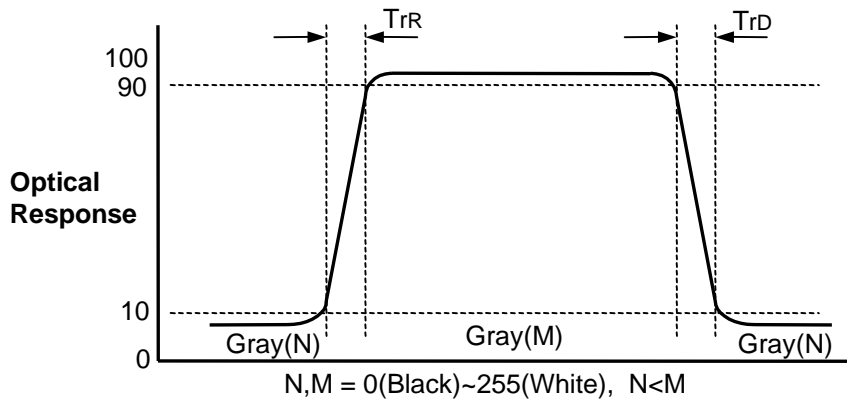

FIG.3 Response Time

Product Specification

Dimension of viewing angle range

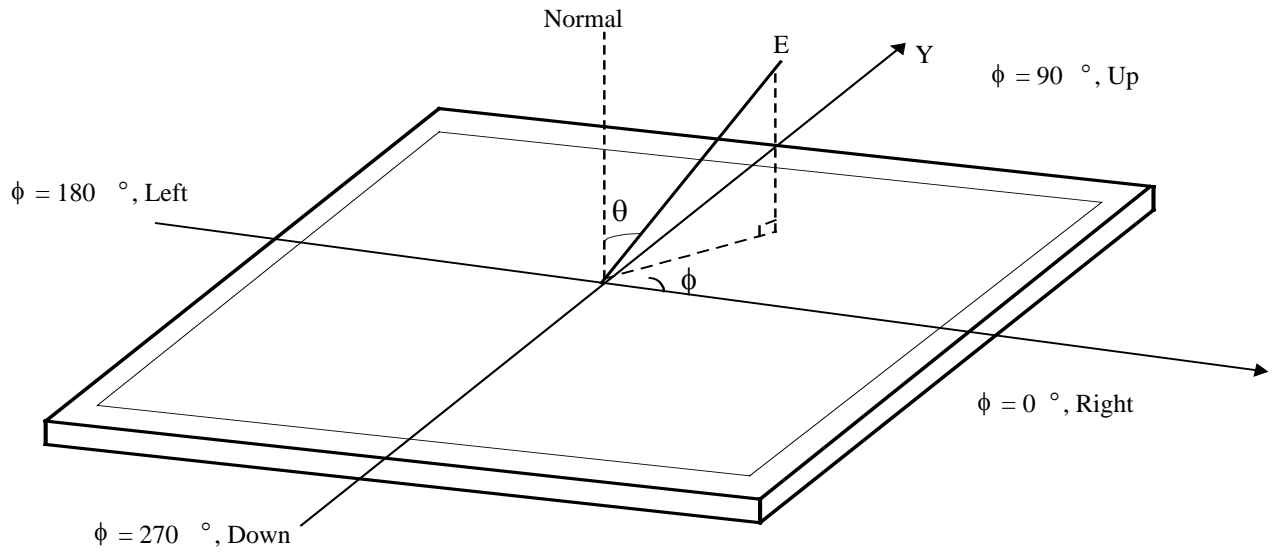

FIG.4 Viewing Angle

Product Specification

5. Mechanical Characteristics

The contents provide general mechanical characteristics. In addition the figures in the next page are detailed mechanical drawing of the LCD module.

Table 14. MECHANICAL CHARACTERISTICS

Item	Value	
Outline Dimension	Horizontal	983.0 mm
	Vertical	576.0 mm
	Depth	51.0 mm
Bezel Area	Horizontal	939.0 mm
	Vertical	531.0 mm
Active Display Area	Horizontal	930.25 mm
	Vertical	523.01 mm
Weight	11.5 Kg (Typ.) , 12.5Kg (Max.)	
Surface Treatment	Hard coating(3H) Anti-glare treatment of the front polarizer	

Note : Please refer to page22 and 23 for mechanic drawings in terms of tolerance.

Product Specification

<FRONT VIEW>

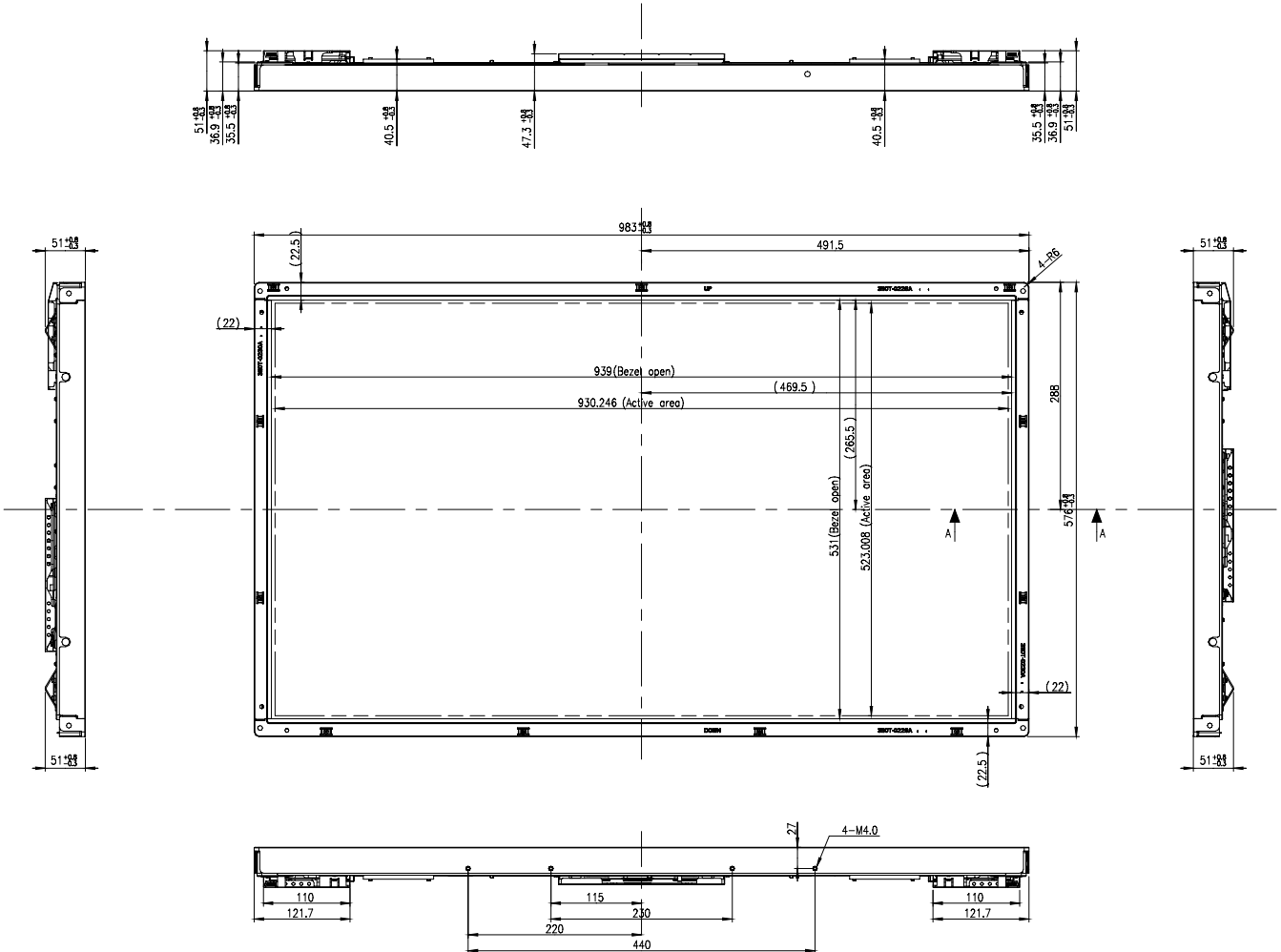

- NOTES
- UNSPECIFIED DIMENSIONAL TOLERANCES TO BE $\pm 0.5\text{mm}$.
 - TILT AND A PARTIAL DISPOSITION TOLERANCE OF DISPLAY AREA ARE AS FOLLOW.
 - X-DIRECTION : $|A-B| < 1.5\text{mm}$
 - Y-DIRECTION : $|C-D| < 1.5\text{mm}$

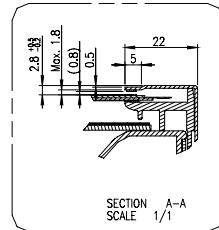
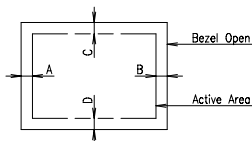

Product Specification

<REAR VIEW>

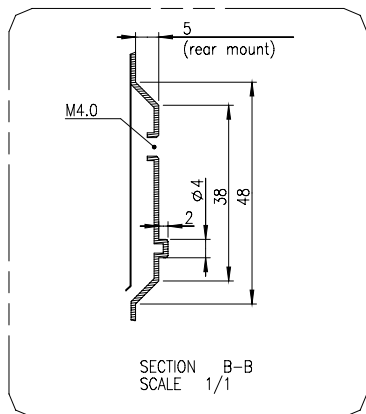
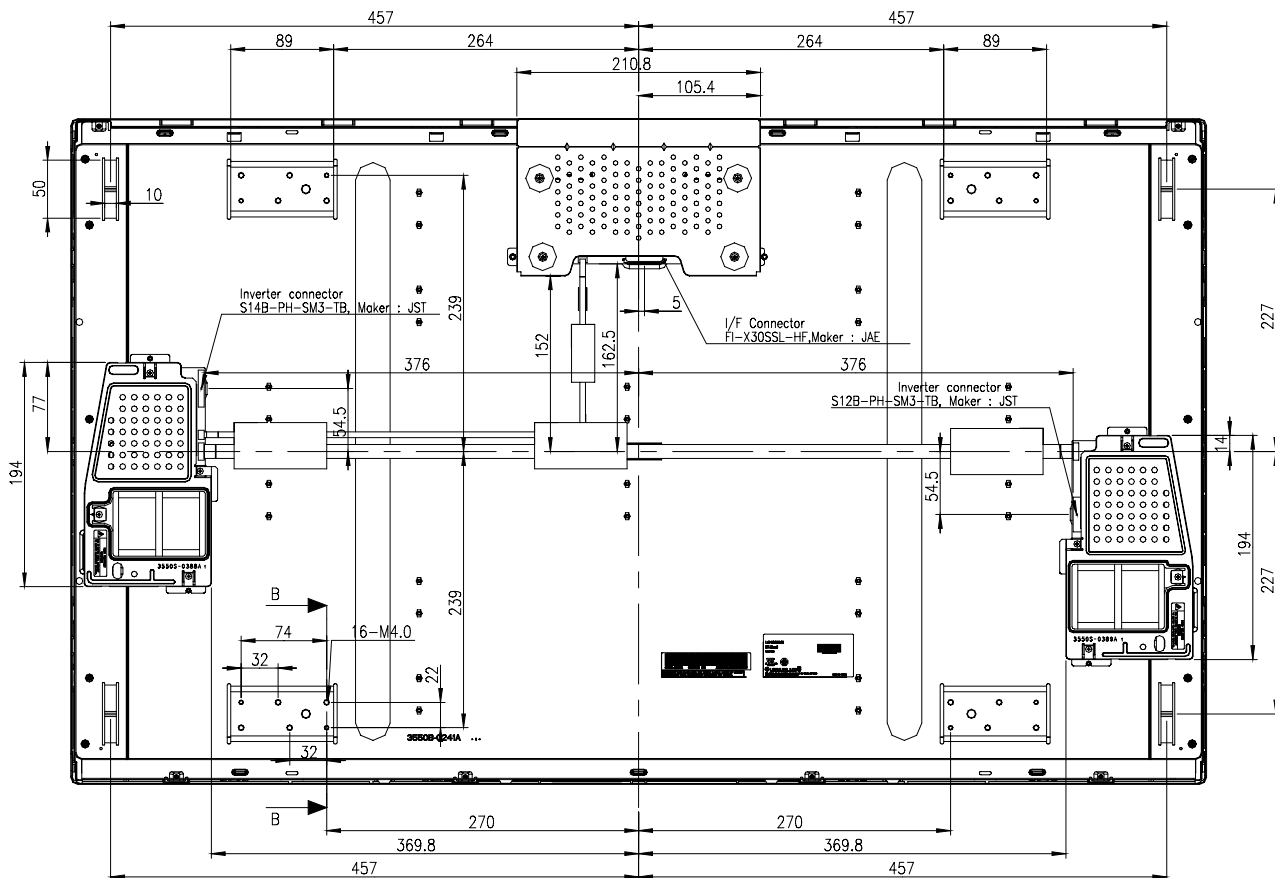

Product Specification

6. Reliability

Table 15. ENVIRONMENT TEST CONDITION

No.	Test Item	Condition
1	High temperature storage test	Ta= 50°C 240h
2	Low temperature storage test	Ta= -20°C 240h
3	High temperature operation test	Ta= 40°C 50%RH 240h
4	Low temperature operation test	Ta= 0°C 240h
5	Vibration test (operating)	Wave form : random Vibration level : 1.0Grms Bandwidth : 10-300Hz Duration : X,Y,Z, 30 min One time each direction
6	Shock test (operating)	Shock level : 50Grms Waveform : half sine wave, 11ms Direction : ± X, ± Y, ± Z One time each direction
7	Humidity condition Operation	Ta= 40 °C ,90%RH
8	Altitude operating storage / shipment	0 - 14,000 feet(4267.2m) 0 - 40,000 feet(12192m)

Product Specification

7. International standards

7-1. Safety

- a) UL 60065, 7th Edition, dated June 30, 2003, Underwriters Laboratories, Inc., Standard for Audio, Video and Similar Electronic Apparatus.
- b) CAN/CSA C22.2, No. 60065:03, Canadian Standards Association, Standard for Audio, Video and Similar Electronic Apparatus.
- c) IEC60065:2001, 7th Edition CB-scheme and EN 60065:2002, Safety requirements for Audio, Video and Similar Electronic Apparatus..

7-2. EMC

- a) ANSI C63.4 "Methods of Measurement of Radio-Noise Emissions from Low-Voltage Electrical and Electrical Equipment in the Range of 9kHz to 40GHz." American National Standards Institute(ANSI), 1992
- b) C.I.S.P.R "Limits and Methods of Measurement of Radio Interface Characteristics of Information Technology Equipment." International Special Committee on Radio Interference.
- c) EN 55022 "Limits and Methods of Measurement of Radio Interface Characteristics of Information Technology Equipment." European Committee for Electrotechnical Standardization.(CENELEC), 1998 (Including A1: 2000)

Product Specification

8. Packing

8-1. Designation of Lot Mark

a) Lot Mark

A	B	C	D	E	F	G	H	I	J	K	L	M
---	---	---	---	---	---	---	---	---	---	---	---	---

A,B,C : SIZE(INCH)

E : MONTH

G ~ M : SERIAL NO.

D : YEAR

F : FACTORY CODE

Note

1. YEAR

Year	2001	2002	2003	2004	2005	2006	2007	2008	2009	2010
Mark	1	2	3	4	5	6	7	8	9	0

2. MONTH

Month	Jan	Feb	Mar	Apr	May	Jun	Jul	Aug	Sep	Oct	Nov	Dec
Mark	1	2	3	4	5	6	7	8	9	A	B	C

3. FACTORY CODE

Factory Code	LPL Gumi	LPL Nanjing	Paju
Mark	K	C	P

b) Location of Lot Mark

Serial No. is printed on the label. The label is attached to the backside of the LCD module.
 This is subject to change without prior notice.

8-2. Packing Form

a) Package quantity in one box : 12 pcs

b) Box Size :1150 mm X 1020 mm X 815 mm.

Product Specification

9. Precautions

Please pay attention to the followings when you use this TFT LCD module.

9-1. Mounting Precautions

- (1) You must mount a module using holes arranged in four corners or four sides.
- (2) You should consider the mounting structure so that uneven force (ex. Twisted stress) is not applied to the module. And the case on which a module is mounted should have sufficient strength so that external force is not transmitted directly to the module.
- (3) Please attach the surface transparent protective plate to the surface in order to protect the polarizer. Transparent protective plate should have sufficient strength in order to resist external force.
- (4) You should adopt radiation structure to satisfy the temperature specification.
- (5) Acetic acid type and chlorine type materials for the cover case are not desirable because the former generates corrosive gas of attacking the polarizer at high temperature and the latter causes circuit break by electro-chemical reaction.
- (6) Do not touch, push or rub the exposed polarizers with glass, tweezers or anything harder than HB pencil lead. And please do not rub with dust clothes with chemical treatment. Do not touch the surface of polarizer for bare hand or greasy cloth.(Some cosmetics are detrimental to the polarizer.)
- (7) When the surface becomes dusty, please wipe gently with absorbent cotton or other soft materials like chamois soaks with petroleum benzene. Normal-hexane is recommended for cleaning the adhesives used to attach front / rear polarizers. Do not use acetone, toluene and alcohol because they cause chemical damage to the polarizer.
- (8) Wipe off saliva or water drops as soon as possible. Their long time contact with polarizer causes deformations and color fading.
- (9) Do not open the case because inside circuits do not have sufficient strength.

9-2. Operating Precautions

- (1) The spike noise causes the mis-operation of circuits. It should be lower than following voltage :
 $V = \pm 200\text{mV}$ (Over and under shoot voltage)
- (2) Response time depends on the temperature.(In lower temperature, it becomes longer.)
- (3) Brightness depends on the temperature. (In lower temperature, it becomes lower.)
And in lower temperature, response time(required time that brightness is stable after turned on) becomes longer.
- (4) Be careful for condensation at sudden temperature change. Condensation makes damage to polarizer or electrical contacted parts. And after fading condensation, smear or spot will occur.
- (5) When fixed patterns are displayed for a long time, remnant image is likely to occur.
- (6) Module has high frequency circuits. Sufficient suppression to the electromagnetic interference shall be done by system manufacturers. Grounding and shielding methods may be important to minimized the interference.
- (7) Please do not give any mechanical and/or acoustical impact to LCM. Otherwise, LCM can't be operated its full characteristics perfectly.
- (8) A screw which is fastened up the steels should be a machine screw.
(if not, it causes metallic foreign material and deal LCM a fatal blow)
- (9) Please do not set LCD module on its edge.

Product Specification

9-3. Electrostatic Discharge Control

Since a module is composed of electronic circuits, it is not strong to electrostatic discharge. Make certain that treatment persons are connected to ground through wrist band etc. And don't touch interface pin directly.

9-4. Precautions for Strong Light Exposure

Strong light exposure causes degradation of polarizer and color filter.

9-5. Storage

When storing modules as spares for a long time, the following precautions are necessary.

- (1) Store them in a dark place. Do not expose the module to sunlight or fluorescent light. Keep the temperature between 5°C and 35°C at normal humidity.
- (2) The polarizer surface should not come in contact with any other object.
It is recommended that they be stored in the container in which they were shipped.

9-6. Handling Precautions for Protection Film

- (1) The protection film is attached to the bezel with a small masking tape.
When the protection film is peeled off, static electricity is generated between the film and polarizer.
This should be peeled off slowly and carefully by people who are electrically grounded and with well ion-blown equipment or in such a condition, etc.
- (2) When the module with protection film attached is stored for a long time, sometimes there remains a very small amount of glue still on the bezel after the protection film is peeled off.
- (3) You can remove the glue easily. When the glue remains on the bezel surface or its vestige is recognized, please wipe them off with absorbent cotton waste or other soft material like chamois soaked with normal-hexane.

Product Specification

APPENDIX-

LC420WX5-SLA1 – Pallet Ass'y

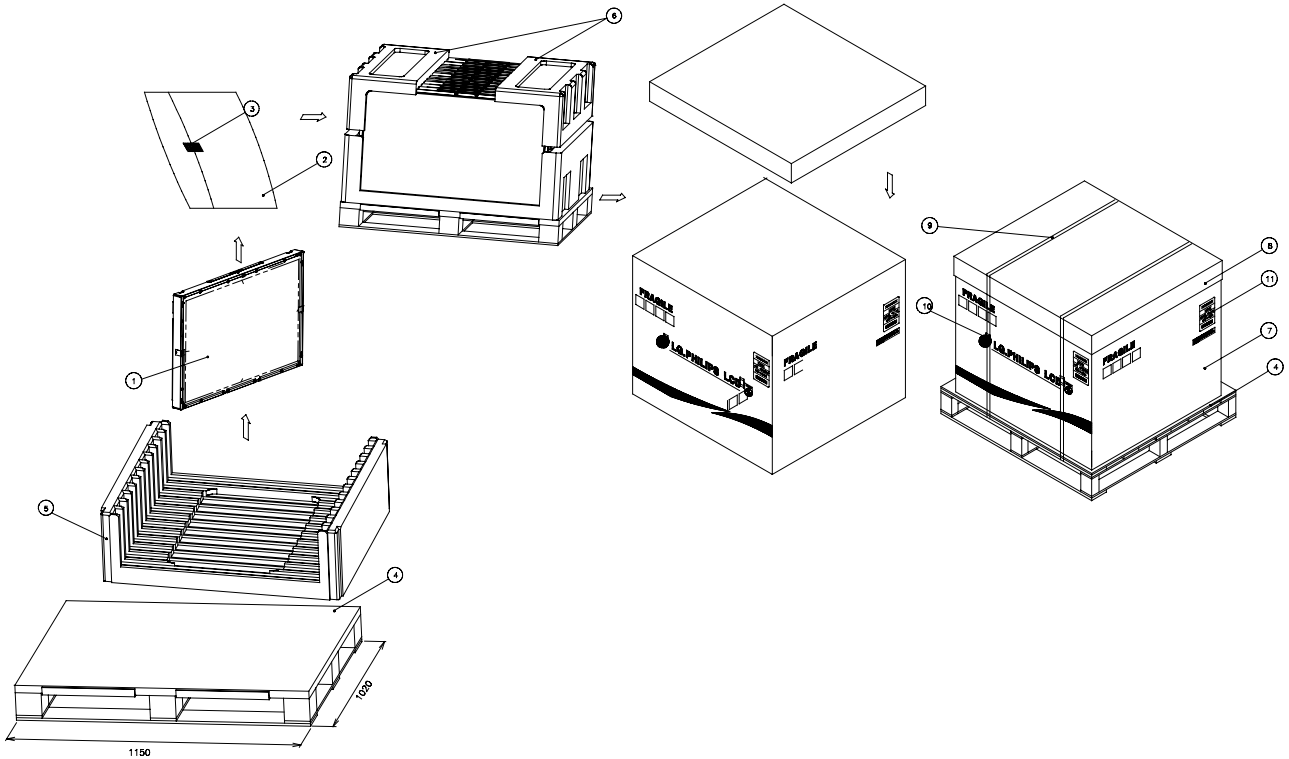

NO.	DESCRIPTION	MATERIAL
1	LCD Module	
2	BAG	42INCH
3	TAPE	MASKING 20MM X 50M
4	PALLET	PAPER 1140X1000X138MM
5	PACKING	EPS
6	PACKING	EPS
7	ANGLE PACKING	PAPER
8	ANGLE COVER	PAPER
9	BAND,CLIP	STEEL
10	BAND	PP
11	LABEL	YUPO PAPER 80G 100X100

APPENDIX-

LCM Label

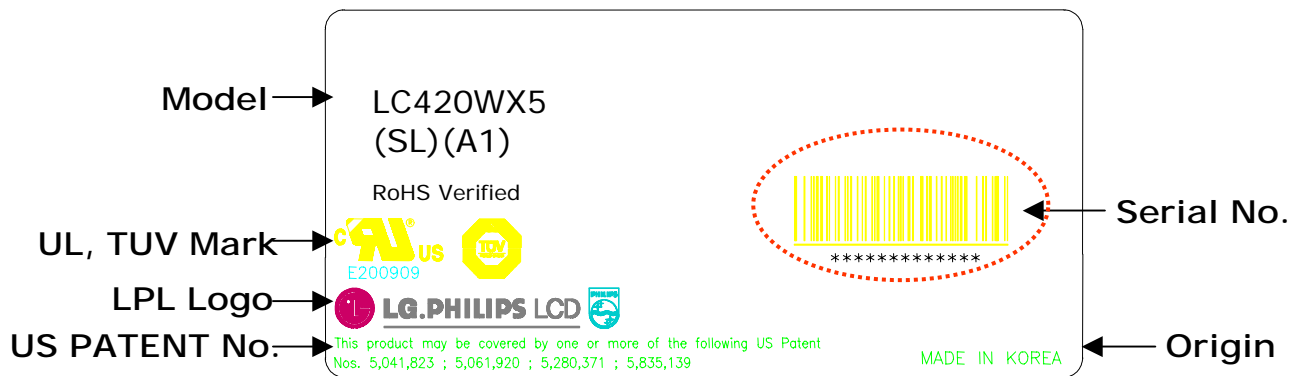

Serial No. (See CAS 26page for more information)

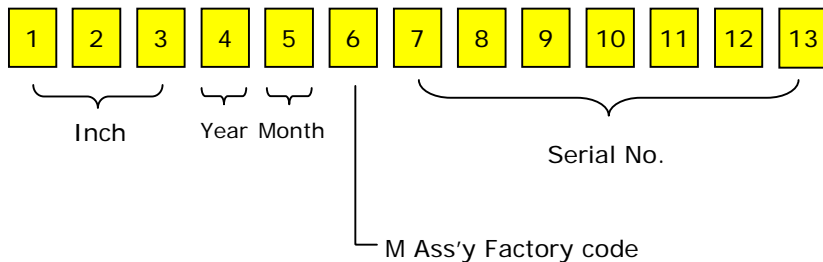

APPENDIX-

Pallet Label

LC420WX5	
SLA1	
12 PCS	001/01-01
REMARK	
MADE IN KOREA	RoHS Verified
 ***** **	