

## Product Specification

# SPECIFICATION FOR APPROVAL

(●) Preliminary Specification

( ) Final Specification

|       |                     |
|-------|---------------------|
| Title | 47.0" WUXGA TFT LCD |
|-------|---------------------|

|       |  |
|-------|--|
| BUYER |  |
| MODEL |  |

|          |                      |
|----------|----------------------|
| SUPPLIER | LG Display Co., Ltd. |
| *MODEL   | LC470EUD             |
| SUFFIX   | SEF2 (RoHS Verified) |

\*When you obtain standard approval,  
please use the above model name without suffix

| APPROVED BY | SIGNATURE DATE |
|-------------|----------------|
| /           |                |
| /           |                |
| /           |                |

Please return 1 copy for your confirmation with your signature and comments.

| APPROVED BY              | SIGNATURE DATE |
|--------------------------|----------------|
| Y.S.Park / Team Leader   |                |
| <b>REVIEWED BY</b>       |                |
| S.S.Lee / Project Leader |                |
| <b>PREPARED BY</b>       |                |
| Y.D.Lee / Engineer       |                |

**TV Product Development Dept.  
LG Display Co., Ltd.**

## Product Specification

**CONTENTS**

| Number | ITEM                                     | Page |
|--------|--|------|
|        | COVER                                    | 0    |
|        | CONTENTS                                 | 1    |
|        | RECORD OF REVISIONS                      | 2    |
| 1      | GENERAL DESCRIPTION                      | 3    |
| 2      | ABSOLUTE MAXIMUM RATINGS                 | 4    |
| 3      | ELECTRICAL SPECIFICATIONS                | 5    |
| 3-1    | ELECTRICAL CHARACTERISTICS               | 5    |
| 3-2    | INTERFACE CONNECTIONS                    | 7    |
| 3-3    | SIGNAL TIMING SPECIFICATIONS             | 10   |
| 3-4    | LVDS SIGNAL SPECIFICATIONS               | 11   |
| 3-5    | COLOR DATA REFERENCE                     | 14   |
| 3-6    | POWER SEQUENCE                           | 15   |
| 4      | OPTICAL SPECIFICATIONS                   | 17   |
| 5      | MECHANICAL CHARACTERISTICS               | 24   |
| 6      | RELIABILITY                              | 27   |
| 7      | INTERNATIONAL STANDARDS                  | 28   |
| 7-1    | SAFETY                                   | 28   |
| 7-2    | EMC                                      | 28   |
| 7-3    | ENVIRONMENT                              | 28   |
| 8      | PACKING                                  | 29   |
| 8-1    | INFORMATION OF LCM LABEL                 | 29   |
| 8-2    | PACKING FORM                             | 29   |
| 9      | PRECAUTIONS                              | 30   |
| 9-1    | MOUNTING PRECAUTIONS                     | 30   |
| 9-2    | OPERATING PRECAUTIONS                    | 30   |
| 9-3    | ELECTROSTATIC DISCHARGE CONTROL          | 31   |
| 9-4    | PRECAUTIONS FOR STRONG LIGHT EXPOSURE    | 31   |
| 9-5    | STORAGE                                  | 31   |
| 9-6    | HANDLING PRECAUTIONS FOR PROTECTION FILM | 31   |
| 9-7    | OPERAGING CONDITION GUIDE                | 31   |

Product Specification

**RECORD OF REVISIONS**

| Revision No. | Revision Date | Page | Description                             |
|--------------|---------------|------|---|
| 0.0          | Sep, 06, 2011 | -    | Preliminary Specification (First Draft) |
|              |               |      |   |
|              |               |      |   |
|              |               |      |   |
|              |               |      |   |
|              |               |      |   |
|              |               |      |   |
|              |               |      |   |
|              |               |      |   |
|              |               |      |   |
|              |               |      |   |
|              |               |      |   |
|              |               |      |   |
|              |               |      |   |
|              |               |      |   |
|              |               |      |   |
|              |               |      |   |
|              |               |      |   |
|              |               |      |   |
|              |               |      |   |
|              |               |      |   |
|              |               |      |   |
|              |               |      |   |
|              |               |      |   |
|              |               |      |   |
|              |               |      |   |
|              |               |      |   |
|              |               |      |   |
|              |               |      |   |
|              |               |      |   |
|              |               |      |   |
|              |               |      |   |
|              |               |      |   |
|              |               |      |   |
|              |               |      |   |
|              |               |      |   |
|              |               |      |   |
|              |               |      |   |
|              |               |      |   |
|              |               |      |   |
|              |               |      |   |
|              |               |      |   |
|              |               |      |   |

## Product Specification

## 1. General Description

The LC470EUD is a Color Active Matrix Liquid Crystal Display with an integral Light Emitting Diode (LED) backlight system. The matrix employs a-Si Thin Film Transistor as the active element. It is a transmissive display type which is operating in the normally black mode. It has a 46.96 inch diagonally measured active display area with WUXGA resolution (1080 vertical by 1920 horizontal pixel array). Each pixel is divided into Red, Green and Blue sub-pixels or dots which are arrayed in vertical stripes. Gray scale or the luminance of the sub-pixel color is determined with a 10-bit gray scale signal for each dot. Therefore, it can present a palette of more than 1.06Billion colors.

It has been designed to apply the 10-bit 4-port LVDS interface.

It is intended to support LCD TV, PCTV where high brightness, super wide viewing angle, high color gamut, high color depth and fast response time are important.

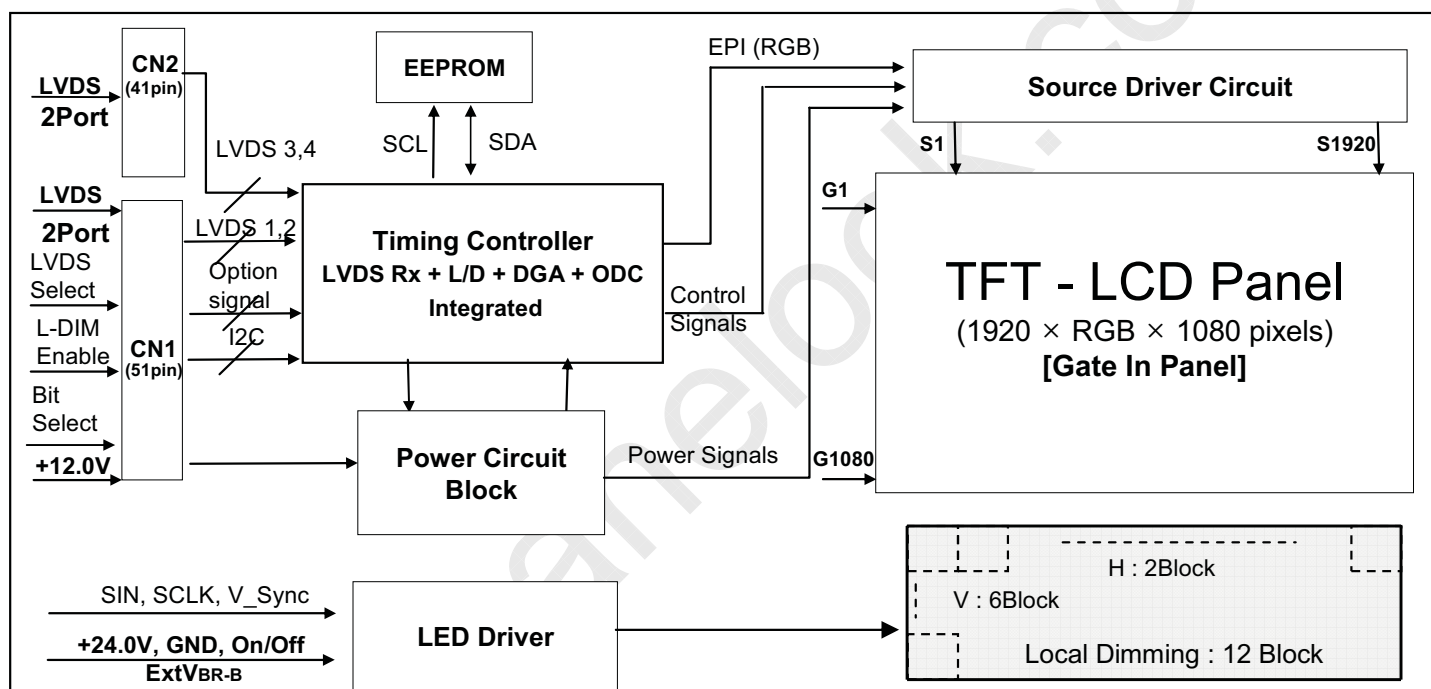

## General Features

|                       |  |
|-----------------------|--|
| Active Screen Size    | 46.96 inches(1192.87mm) diagonal   |
| Outline Dimension     | 1070.6(H) × 622.0(V) X 9.9(B)/23.1 mm(D) (Typ.)                                    |
| Pixel Pitch           | 0.5415 mm x 0.5415 mm  |
| Pixel Format          | 1920 horiz. by 1080 vert. Pixels, RGB stripe arrangement                           |
| Color Depth           | 10bit(D), 1.06Billion colors   |
| Luminance, White      | 400 cd/m <sup>2</sup> (Center 1point ,Typ.)  |
| Viewing Angle (CR>10) | Viewing angle free ( R/L 178 (Min.), U/D 178 (Min.))                               |
| Power Consumption     | Total 89.9W(TBD) (Typ.) [Logic=8.0W(TBD) , LED Driver=81.9W(TBD) (ExtVbr_B=100% )] |
| Weight                | 10.9(TBD) Kg (Typ.)  |
| Display Mode          | Transmissive mode, Normally black  |
| Surface Treatment     | Hard coating(2H), Anti-glare treatment of the front polarizer (Haze < 1%)          |

## Product Specification

## 2. Absolute Maximum Ratings

The following items are maximum values which, if exceeded, may cause faulty operation or permanent damage to the LCD module.

**Table 1. ABSOLUTE MAXIMUM RATINGS**

| Parameter                      |             | Symbol                             | Value |        | Unit            | Note |
|--------------------------------|-------------|------------------------------------|-------|--------|-----------------|------|
|                                |             |                                    | Min   | Max    |                 |      |
| Power Input Voltage            | LCD Circuit | V <sub>LCD</sub>                   | -0.3  | +14.0  | V <sub>DC</sub> | 1    |
|                                | Driver      | V <sub>BL</sub>                    | -0.3  | + 27.0 | V <sub>DC</sub> |      |
| Driver Control Voltage         | ON/OFF      | V <sub>OFF</sub> / V <sub>ON</sub> | -0.3  | +5.5   | V <sub>DC</sub> | 1    |
|                                | Brightness  | EXTVBR-B                           | 0.0   | +5.5   | V <sub>DC</sub> |      |
| T-Con Option Selection Voltage |             | V <sub>LOGIC</sub>                 | -0.3  | +4.0   | V <sub>DC</sub> |      |
| Operating Temperature          |             | T <sub>OP</sub>                    | 0     | +50    | °C              | 2,3  |
| Storage Temperature            |             | T <sub>ST</sub>                    | -20   | +65    | °C              |      |
| Panel Front Temperature        |             | T <sub>SUR</sub>                   | -     | +68    | °C              | 4    |
| Operating Ambient Humidity     |             | H <sub>OP</sub>                    | 10    | 90     | %RH             | 2,3  |
| Storage Humidity               |             | H <sub>ST</sub>                    | 10    | 90     | %RH             |      |

Note1. Ambient temperature condition ( $T_a = 25 \pm 2 \text{ }^\circ\text{C}$ )

2. Temperature and relative humidity range are shown in the figure below.

Wet bulb temperature should be Max 39°C, and no condensation of water.

3. Gravity mura can be guaranteed below 40°C condition.

4. The maximum operating temperatures is based on the test condition that the surface temperature of display area is less than or equal to 68°C with LCD module alone in a temperature controlled chamber. Thermal management should be considered in final product design to prevent the surface temperature of display area from being over 68°C. The range of operating temperature may be degraded in case of improper thermal management in final product design.

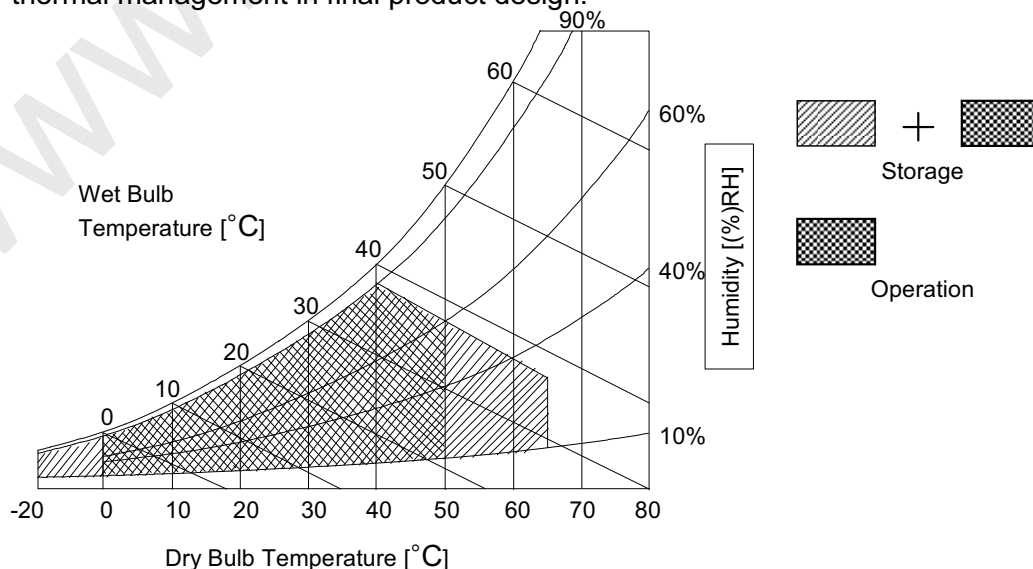

## Product Specification

### 3. Electrical Specifications

#### 3-1. Electrical Characteristics

It requires two power inputs. One is employed to power for the LCD circuit. The other is used for the LED backlight and LED Driver circuit.

**Table 2. ELECTRICAL CHARACTERISTICS**

| Parameter           | Symbol            | Value |          |           | Unit            | Note |
|---------------------|-------------------|-------|----------|-----------|-----------------|------|
|                     |                   | Min   | Typ      | Max       |                 |      |
| <b>Circuit :</b>    |                   |       |          |           |                 |      |
| Power Input Voltage | V <sub>LCD</sub>  | 10.8  | 12.0     | 13.2      | V <sub>DC</sub> |      |
| Power Input Current | I <sub>LCD</sub>  | -     | 665(TBD) | 865(TBD)  | mA              | 1    |
|                     |                   | -     | 930(TBD) | 1210(TBD) | mA              | 2    |
| Power Consumption   | P <sub>LCD</sub>  | -     | 8.0(TBD) | 10.4(TBD) | Watt            | 1    |
| Rush current        | I <sub>RUSH</sub> | -     | -        | 3.0(TBD)  | A               | 3    |

Note 1. The specified current and power consumption are under the  $V_{LCD}=12.0V$ ,  $T_a=25 \pm 2^\circ C$ ,  $f_v=120Hz$  condition, and mosaic pattern(8 x 6) is displayed and  $f_v$  is the frame frequency.

2. The current is specified at the maximum current pattern.

3. The duration of rush current is about 2ms and rising time of power input is 0.5ms (min.).

4. Ripple voltage level is recommended under  $\pm 5\%$  of typical voltage

White : 1023 Gray

Black : 0 Gray

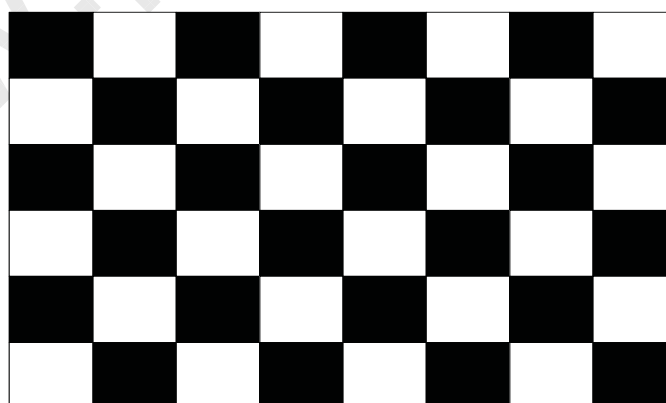
**Mosaic Pattern(8 x 6)**

## Product Specification

Table 3. ELECTRICAL CHARACTERISTICS (Continue)

| Parameter                                | Symbol                       | Values     |        |      | Unit | Notes                                |                                  |  |
|--|------------------------------|------------|--------|------|------|--------------------------------------|----------------------------------|--|
|  |                              | Min        | Typ    | Max  |      |                                      |                                  |  |
| LED Driver :                             |                              |            |        |      |      |                                      |                                  |  |
| Power Supply Input Voltage               | VBL                          | 22.8       | 24.0   | 25.2 | Vdc  | 1                                    |                                  |  |
| Power Supply Input Current               | IBL                          | -          | 3.4    | 3.7  | A    | 1                                    |                                  |  |
| Power Supply Input Current (In-Rush)     | In-rush                      | -          | -      | 5.7  | A    | VBL = 22.8V<br>Ext VBR-B = 100%<br>4 |                                  |  |
| Power Consumption                        | PBL                          | -          | 81.9   | 89.5 | W    | 1                                    |                                  |  |
| Input Voltage for Control System Signals | On/Off                       | On         | V on   | 2.5  | -    | 5.0                                  | Vdc                              |  |
|  |                              | Off        | V off  | -0.3 | 0.0  | 0.7                                  | Vdc                              |  |
|  | Brightness Adjust            | ExtVBR-B   | 1      | -    | 100  | %                                    | On Duty<br>6                     |  |
|  | PWM Frequency for NTSC & PAL | PAL        |        | 100  |      | Hz                                   | 3                                |  |
|  |                              | NTSC       |        | 120  |      | Hz                                   | 3                                |  |
|  | Pulse Duty Level (PWM)       | High Level | 2.4    | -    | 5.0  | Vdc                                  | HIGH : on duty<br>LOW : off duty |  |
| Low Level                                |                              | 0.0        | -      | 0.7  | Vdc  |                                      |                                  |  |
| LED :                                    |                              |            |        |      |      |                                      |                                  |  |
| Life Time                                |                              | 30,000     | 50,000 |      | Hrs  | 2                                    |                                  |  |

## Notes :

- Electrical characteristics are determined after the unit has been 'ON' and stable for approximately 60 minutes at  $25\pm 2^{\circ}\text{C}$ . The specified current and power consumption are under the typical supply Input voltage 24V and VBR (ExtVBR-B : 100%), it is total power consumption.
- The life time (MTTF) is determined as the time which luminance of the LED is 50% compared to that of initial value at the typical LED current (ExtVBR-B : 100%) on condition of continuous operating in LCM state at  $25\pm 2^{\circ}\text{C}$ .
- LGD recommend that the PWM freq. is synchronized with One time harmonic of V\_sync signal of system. Though PWM frequency is over 120Hz (max 252Hz), function of LED Driver is not affected.
- The duration of rush current is about 200ms. This duration is applied to LED on time.
- Even though inrush current is over the specified value, there is no problem if I<sup>2</sup>T spec of fuse is satisfied.
- Ext\_PWM Signal have to input available duty range.  
Between 99% and 100% ExtVBR-B duty have to be avoided. (  $99\% < \text{ExtVBR-B} < 100\%$  )  
But ExtVBR-B 0% and 100% are available.

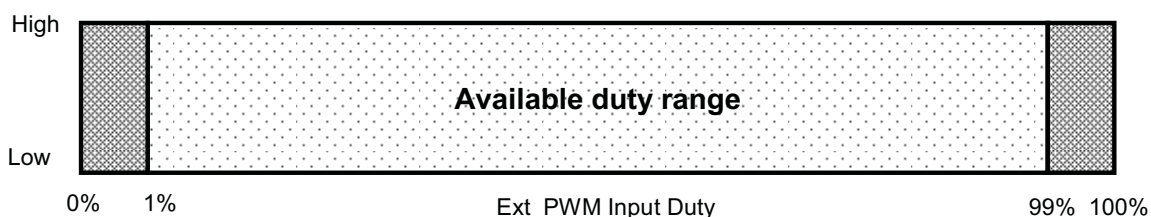

## Product Specification

### 3-2. Interface Connections

This LCD module employs two kinds of interface connection, 51-pin connector and 41-pin connector are used for the module electronics and 14-pin connector is used for the integral backlight system.

#### 3-2-1. LCD Module

- LCD Connector(CN1): FI-RE51S-HF(manufactured by JAE) or compatible
- Mating Connector : FI-R51HL(JAE) or compatible

**Table 4-1. MODULE CONNECTOR(CN1) PIN CONFIGURATION**

| No | Symbol       | Description                                | No | Symbol     | Description                          |
|----|--------------|--|----|------------|--------------------------------------|
| 1  | PCID_EN      | 'H' : PCID Enable, 'L' or NC: PCID Disable | 27 | Bit Select | 'H' or NC= 10bit(D) , 'L' = 8bit     |
| 2  | NC           | No Connection (Note 4)                     | 28 | R2AN       | SECOND LVDS Receiver Signal (A-)     |
| 3  | NC           | No Connection (Note 4)                     | 29 | R2AP       | SECOND LVDS Receiver Signal (A+)     |
| 4  | NC           | No Connection (Note 4)                     | 30 | R2BN       | SECOND LVDS Receiver Signal (B-)     |
| 5  | NC           | No Connection (Note 4)                     | 31 | R2BP       | SECOND LVDS Receiver Signal (B+)     |
| 6  | NC           | No Connection (Note 4)                     | 32 | R2CN       | SECOND LVDS Receiver Signal (C-)     |
| 7  | LVDS Select  | 'H' =JEIDA , 'L' or NC = VESA              | 33 | R2CP       | SECOND LVDS Receiver Signal (C+)     |
| 8  | NC           | No Connection (Note 4)                     | 34 | GND        | Ground                               |
| 9  | NC           | No Connection (Note 4)                     | 35 | R2CLKN     | SECOND LVDS Receiver Clock Signal(-) |
| 10 | L-DIM Enable | 'H' = Enable , 'L' or NC = Disable         | 36 | R2CLKP     | SECOND LVDS Receiver Clock Signal(+) |
| 11 | GND          | Ground                                     | 37 | GND        | Ground                               |
| 12 | R1AN         | FIRST LVDS Receiver Signal (A-)            | 38 | R2DN       | SECOND LVDS Receiver Signal (D-)     |
| 13 | R1AP         | FIRST LVDS Receiver Signal (A+)            | 39 | R2DP       | SECOND LVDS Receiver Signal (D+)     |
| 14 | R1BN         | FIRST LVDS Receiver Signal (B-)            | 40 | R2EN       | SECOND LVDS Receiver Signal (E-)     |
| 15 | R1BP         | FIRST LVDS Receiver Signal (B+)            | 41 | R2EP       | SECOND LVDS Receiver Signal (E+)     |
| 16 | R1CN         | FIRST LVDS Receiver Signal (C-)            | 42 | NC or GND  | No Connection or Ground              |
| 17 | R1CP         | FIRST LVDS Receiver Signal (C+)            | 43 | NC or GND  | No Connection or Ground              |
| 18 | GND          | Ground                                     | 44 | GND        | Ground (Note 7)                      |
| 19 | R1CLKN       | FIRST LVDS Receiver Clock Signal(-)        | 45 | GND        | Ground                               |
| 20 | R1CLKP       | FIRST LVDS Receiver Clock Signal(+)        | 46 | GND        | Ground                               |
| 21 | GND          | Ground                                     | 47 | NC         | No connection                        |
| 22 | R1DN         | FIRST LVDS Receiver Signal (D-)            | 48 | VLCD       | Power Supply +12.0V                  |
| 23 | R1DP         | FIRST LVDS Receiver Signal (D+)            | 49 | VLCD       | Power Supply +12.0V                  |
| 24 | R1EN         | FIRST LVDS Receiver Signal (E-)            | 50 | VLCD       | Power Supply +12.0V                  |
| 25 | R1EP         | FIRST LVDS Receiver Signal (E+)            | 51 | VLCD       | Power Supply +12.0V                  |
| 26 | NC or GND    | No Connection or Ground                    | -  | -          | -                                    |

- Note
1. All GND (ground) pins should be connected together to the LCD module's metal frame.
  2. All VLCD (power input) pins should be connected together.
  3. All Input levels of LVDS signals are based on the EIA 644 Standard.
  4. #1~#6 & #8~#9 NC (No Connection): These pins are used only for LGD (Do not connect)
  5. Specific pin (#10) is used for Local Dimming function of the LCD module.  
If not used, these pins are no connection. (Please see the Appendix III-3 for more information.)
  6. LVDS pin (pin No. #24,25,40,41) are used for 10Bit(D) of the LCD module.  
If used for 8Bit(R), these pins are no connection.
  7. Specific pin No. #44 is used for "No signal detection" of system signal interface.  
It should be GND for NSB (No Signal Black) while the system interface signal is not.  
If this pin is "H", LCD Module displays AGP (Auto Generation Pattern).



## Product Specification

- LCD Connector (CN2) : FI-RE41S-HF (manufactured by JAE) or compatible
- Mating Connector : FI-RE41HL

Table 4-2. MODULE CONNECTOR(CN2) PIN CONFIGURATION

| No | Symbol | Description                         | No | Symbol | Description                         |
|----|--------|-------------------------------------|----|--------|-------------------------------------|
| 1  | NC     | No connection                       | 22 | RE3N   | THIRD LVDS Receiver Signal (E-)     |
| 2  | NC     | No connection                       | 23 | RE3P   | THIRD LVDS Receiver Signal (E+)     |
| 3  | NC     | No connection                       | 24 | GND    | Ground                              |
| 4  | NC     | No connection                       | 25 | GND    | Ground                              |
| 5  | NC     | No connection                       | 26 | RA4N   | FORTH LVDS Receiver Signal (A-)     |
| 6  | NC     | No connection                       | 27 | RA4P   | FORTH LVDS Receiver Signal (A+)     |
| 7  | NC     | No connection                       | 28 | RB4N   | FORTH LVDS Receiver Signal (B-)     |
| 8  | NC     | No connection                       | 29 | RB4P   | FORTH LVDS Receiver Signal (B+)     |
| 9  | GND    | Ground                              | 30 | RC4N   | FORTH LVDS Receiver Signal (C-)     |
| 10 | RA3N   | THIRD LVDS Receiver Signal (A-)     | 31 | RC4P   | FORTH LVDS Receiver Signal (C+)     |
| 11 | RA3P   | THIRD LVDS Receiver Signal (A+)     | 32 | GND    | Ground                              |
| 12 | RB3N   | THIRD LVDS Receiver Signal (B-)     | 33 | RCLK4N | FORTH LVDS Receiver Clock Signal(-) |
| 13 | RB3P   | THIRD LVDS Receiver Signal (B+)     | 34 | RCLK4P | FORTH LVDS Receiver Clock Signal(+) |
| 14 | RC3N   | THIRD LVDS Receiver Signal (C-)     | 35 | GND    | Ground                              |
| 15 | RC3P   | THIRD LVDS Receiver Signal (C+)     | 36 | RD4N   | FORTH LVDS Receiver Signal (D-)     |
| 16 | GND    | Ground                              | 37 | RD4P   | FORTH LVDS Receiver Signal (D+)     |
| 17 | RCLK3N | THIRD LVDS Receiver Clock Signal(-) | 38 | RE4N   | FORTH LVDS Receiver Signal (E-)     |
| 18 | RCLK3P | THIRD LVDS Receiver Clock Signal(+) | 39 | RE4P   | FORTH LVDS Receiver Signal (E+)     |
| 19 | GND    | Ground                              | 40 | GND    | Ground                              |
| 20 | RD3N   | THIRD LVDS Receiver Signal (D-)     | 41 | GND    | Ground                              |
| 21 | RD3P   | THIRD LVDS Receiver Signal (D+)     | -  |        |                                     |

- Note :
1. All GND (ground) pins should be connected together to the LCD module's metal frame.
  2. LVDS pin (pin No. #22,23,38,39) are used for 10Bit(D) of the LCD module.  
If used for 8Bit(R), these pins are no connection.

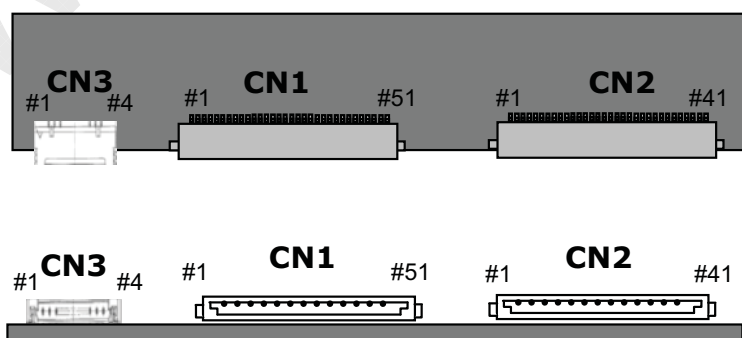

Rear view of LCM

## Product Specification

## 3-2-2. Backlight Module

Master

-LED Driver Connector

: 20022WR - H14B2(Yeonho)

Mating Connector

: 20022HS - 14B2 or Compatible

Table 5. LED DRIVER CONNECTOR PIN CONFIGURATION

| Pin No | Symbol   | Description              | Note |
|--------|----------|--------------------------|------|
| 1      | VBL      | Power Supply +24.0V      |      |
| 2      | VBL      | Power Supply +24.0V      |      |
| 3      | VBL      | Power Supply +24.0V      |      |
| 4      | VBL      | Power Supply +24.0V      |      |
| 5      | VBL      | Power Supply +24.0V      |      |
| 6      | GND      | Backlight Ground         | 1    |
| 7      | GND      | Backlight Ground         |      |
| 8      | GND      | Backlight Ground         |      |
| 9      | GND      | Backlight Ground         |      |
| 10     | GND      | Backlight Ground         |      |
| 11     | Status   | Back Light Status        | 2    |
| 12     | VON/OFF  | Backlight ON/OFF control |      |
| 13     | NC       | Don't care               |      |
| 14     | EXTVBR-B | External PWM             | 3    |

Notes :1. GND should be connected to the LCD module's metal frame.

2. Normal : Low (under 0.7V) / Abnormal : Open

3. High : on duty / Low : off duty, Pin#14 can be opened. ( if Pin #14 is open , EXTVBR-B is 100% )

4. Each impedance of pin #12 and 14 is over 50 [KΩ] .

## ◆ Rear view of LCM

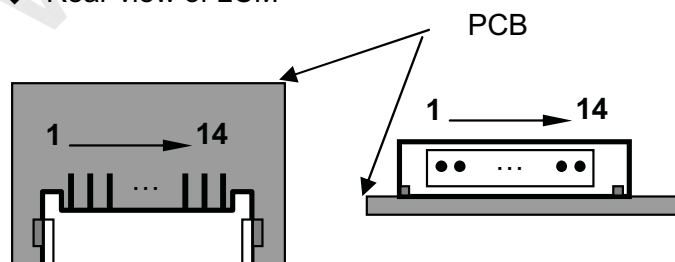

&lt;Master&gt;

## Product Specification

## 3-3. Signal Timing Specifications

Table 6 shows the signal timing required at the input of the LVDS transmitter. All of the interface signal timings should be satisfied with the following specification for normal operation.

Table 6. TIMING TABLE (DE Only Mode)

| ITEM       |                | Symbol          | Min            | Typ            | Max            | Unit  | Note     |
|------------|----------------|-----------------|----------------|----------------|----------------|-------|----------|
| Horizontal | Display Period | t <sub>HV</sub> | 480            | 480            | 480            | tCLK  | 1920 / 4 |
|            | Blank          | t <sub>HB</sub> | 40             | 70             | 200            | tCLK  | 1        |
|            | Total          | t <sub>HP</sub> | 520            | 550            | 680            | tCLK  |          |
| Vertical   | Display Period | t <sub>VV</sub> | 1080           | 1080           | 1080           | Lines |          |
|            | Blank          | t <sub>VB</sub> | 20<br>(228)    | 45<br>(270)    | 86<br>(300)    | Lines | 1        |
|            | Total          | t <sub>VP</sub> | 1100<br>(1308) | 1125<br>(1350) | 1166<br>(1380) | Lines |          |

| ITEM      |            | Symbol           | Min         | Typ          | Max          | Unit | Note               |
|-----------|------------|------------------|-------------|--------------|--------------|------|--------------------|
| Frequency | DCLK       | f <sub>CLK</sub> | 66.97       | 74.25        | 78.00        | MHz  |                    |
|           | Horizontal | f <sub>H</sub>   | 121.8       | 135          | 140          | KHz  | 2                  |
|           | Vertical   | f <sub>V</sub>   | 108<br>(95) | 120<br>(100) | 122<br>(104) | Hz   | 2<br>NTSC<br>(PAL) |

Note: 1. The input of HSYNC & VSYNC signal does not have an effect on normal operation (DE Only Mode).  
If you use spread spectrum of EMI, add some additional clock to minimum value for clock margin.

2. The performance of the electro-optical characteristics may be influenced by variance of the vertical refresh rate and the horizontal frequency

※ Timing should be set based on clock frequency.

Product Specification

3-4. LVDS Signal Specification

3-4-1. LVDS Input Signal Timing Diagram

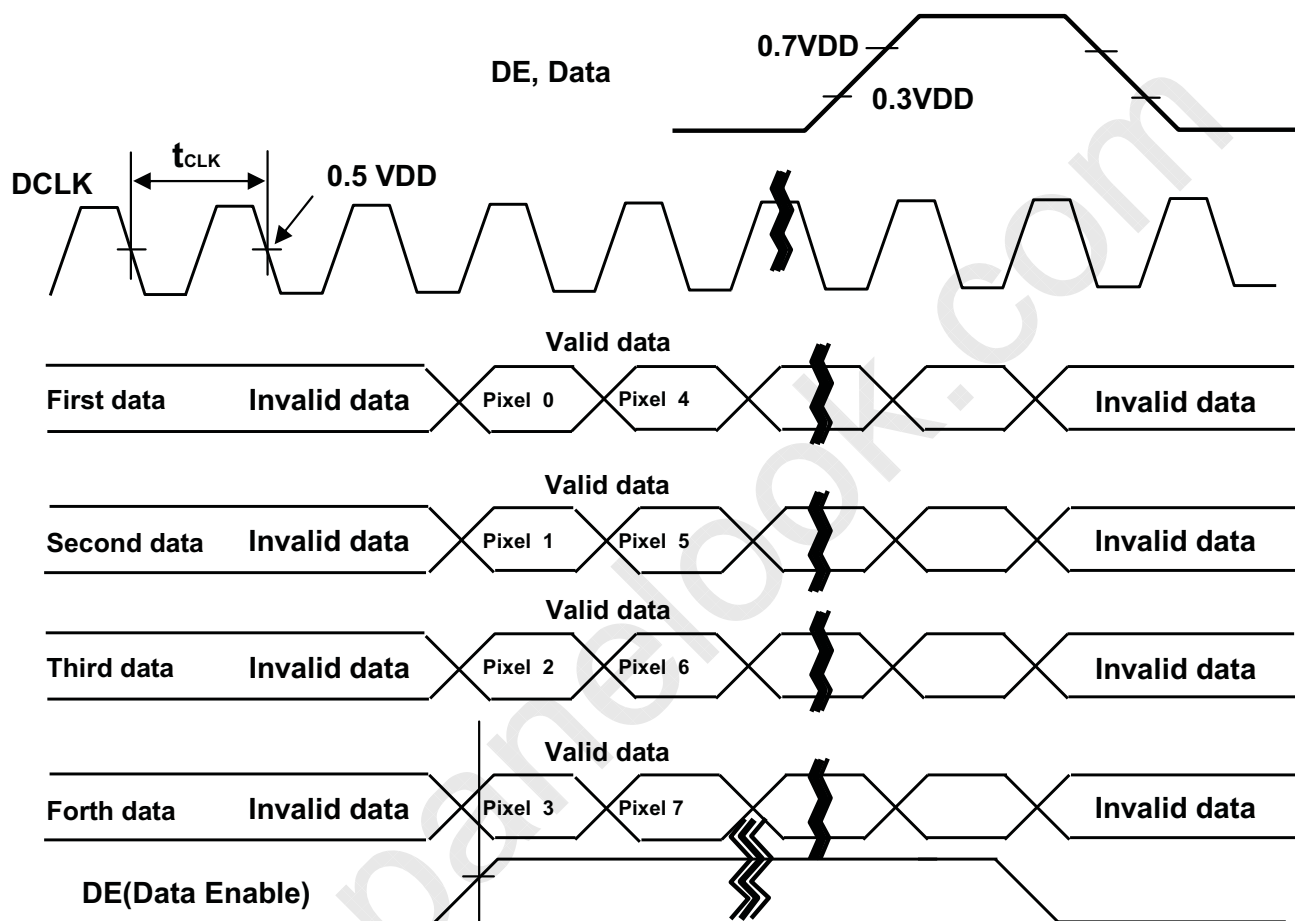

\*  $t_{HB} = t_{HFP} + t_{WH} + t_{HBP}$

\*  $t_{VB} = t_{VFP} + t_{VW} + t_{VBP}$

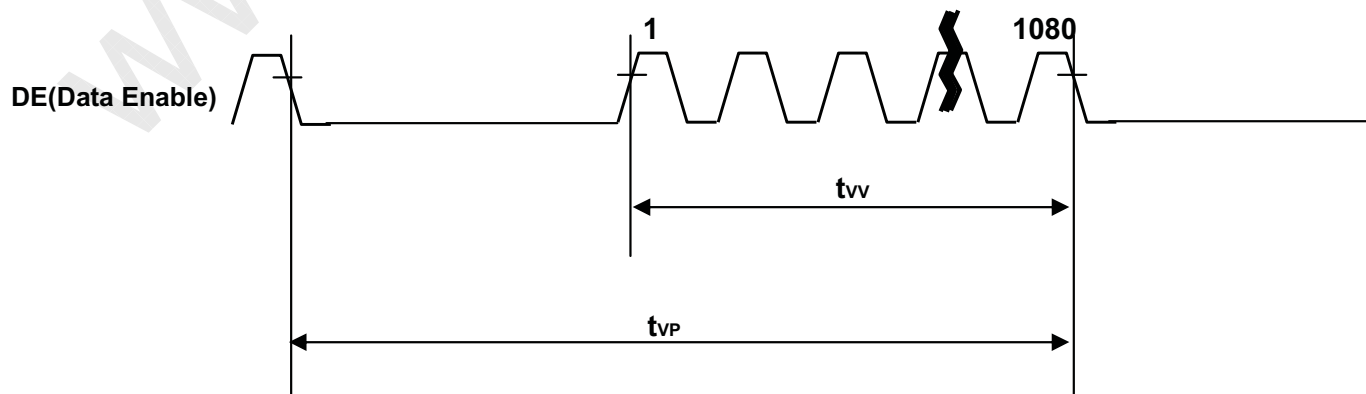

## Product Specification

## 3-4-2. LVDS Input Signal Characteristics

## 1) DC Specification

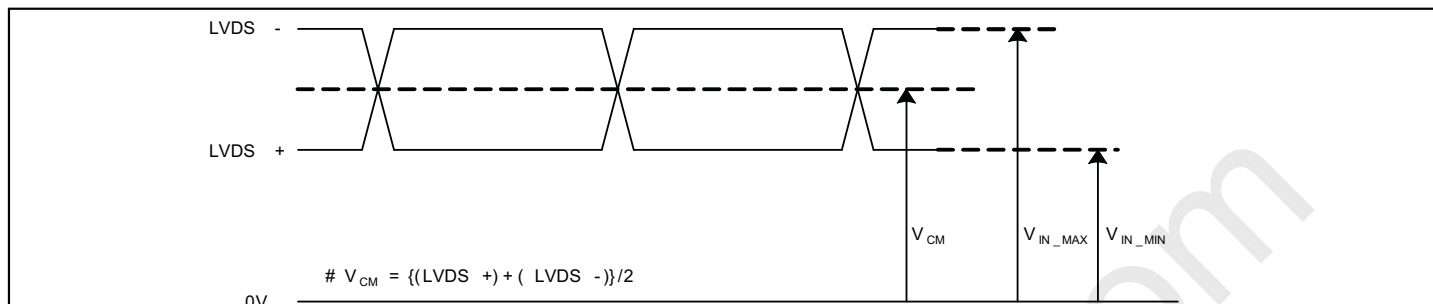

| Description                   | Symbol          | Min | Max | Unit | Note |
|-------------------------------|-----------------|-----|-----|------|------|
| LVDS Common mode Voltage      | $V_{CM}$        | 1.0 | 1.5 | V    | -    |
| LVDS Input Voltage Range      | $V_{IN}$        | 0.7 | 1.8 | V    | -    |
| Change in common mode Voltage | $\Delta V_{CM}$ | -   | 250 | mV   | -    |

## 2) AC Specification

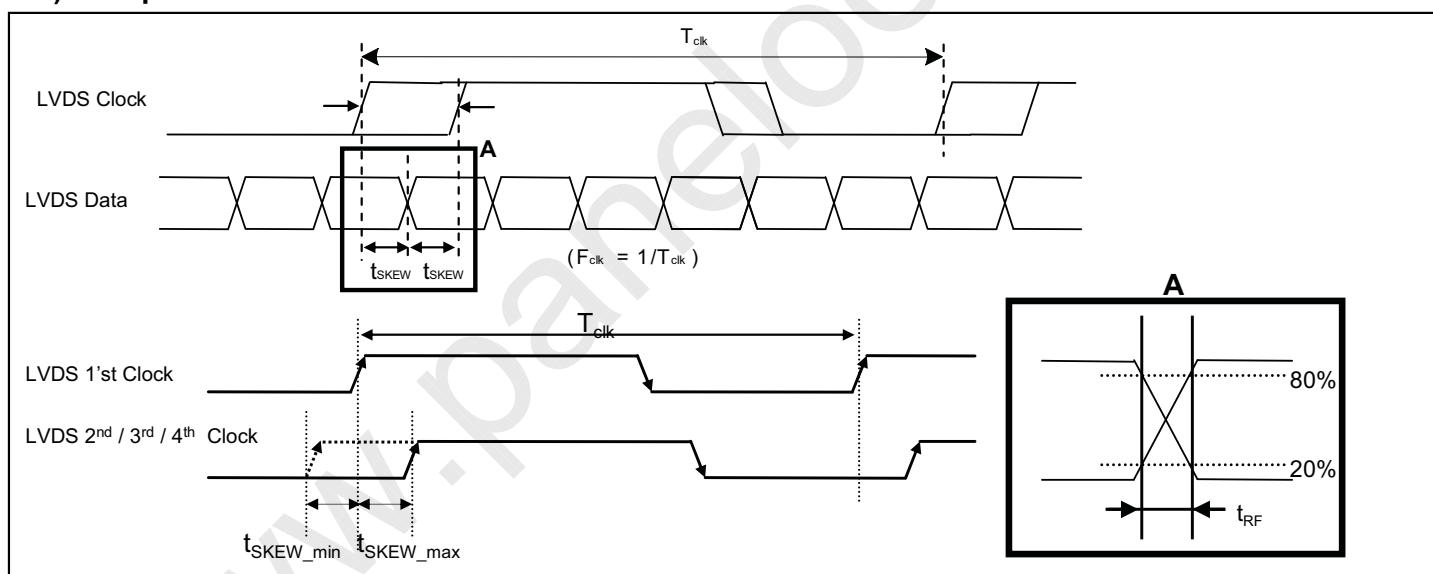

| Description                            | Symbol         | Min         | Max                   | Unit | Note |   |
|--|----------------|-------------|-----------------------|------|------|---|
| LVDS Differential Voltage              | High Threshold | $V_{TH}$    | 100                   | 600  | mV   | 3 |
|  | Low Threshold  | $V_{TL}$    | -600                  | -100 | mV   |   |
| LVDS Clock to Data Skew                | $t_{SKEW}$     | -           | $ (0.2 * T_{clk})/7 $ | ps   | -    |   |
| LVDS Clock/DATA Rising/Falling time    | $t_{RF}$       | 260         | $ (0.3 * T_{clk})/7 $ | ps   | 2    |   |
| Effective time of LVDS                 | $t_{eff}$      | $ \pm 360 $ | -                     | ps   | -    |   |
| LVDS Clock to Clock Skew (Even to Odd) | $t_{SKEW\_EO}$ | -           | $ 1/7 * T_{clk} $     | ps   | -    |   |

Note 1. All Input levels of LVDS signals are based on the EIA 644 Standard.

2. If  $t_{RF}$  isn't enough,  $t_{eff}$  should meet the range.

3. LVDS Differential Voltage is defined within  $t_{eff}$

## Product Specification

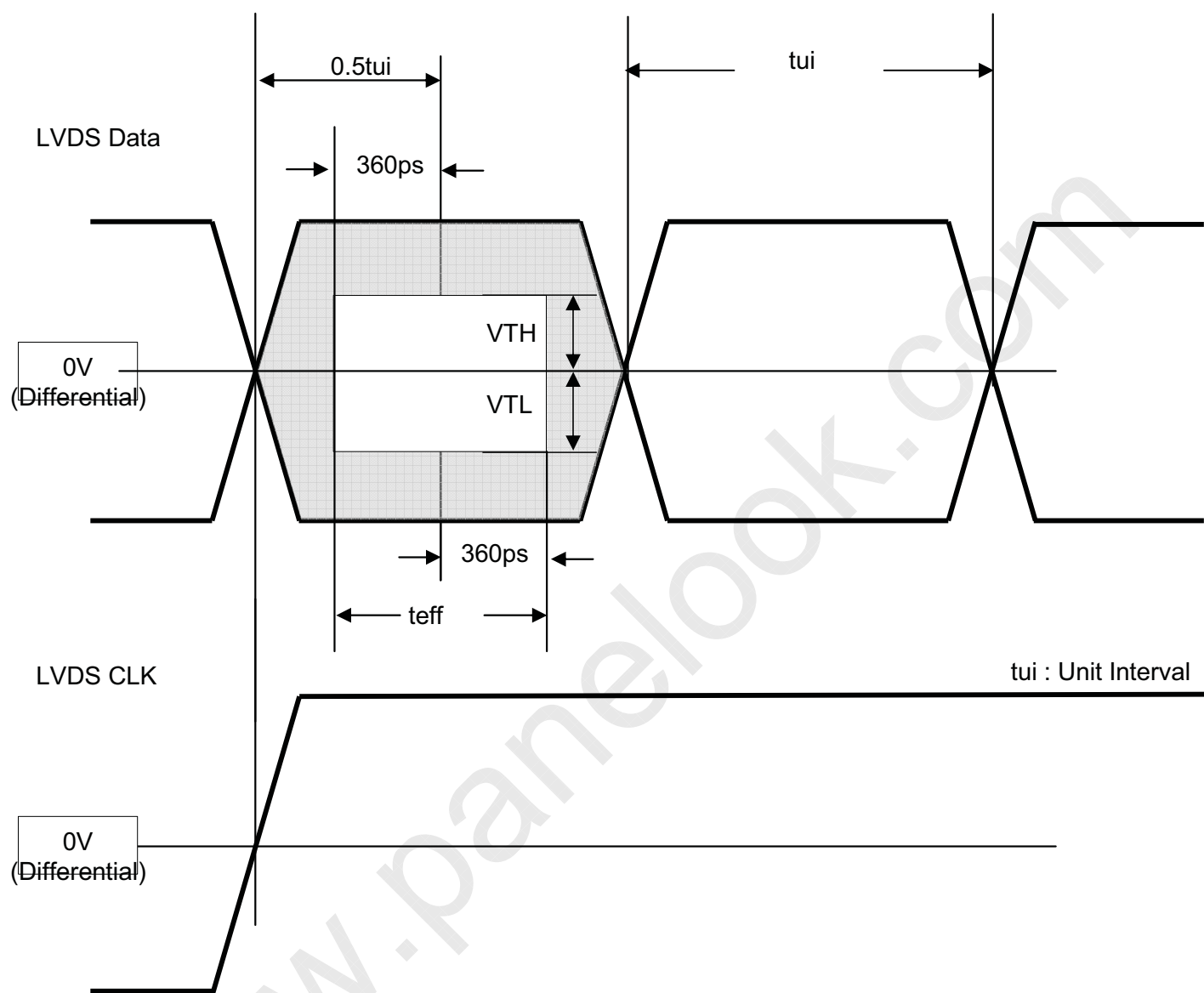

\* This accumulated waveform is tested with differential probe

## Product Specification

## 3-5. Color Data Reference

The brightness of each primary color (red, green, blue) is based on the 10bit gray scale data input for the color. The higher binary input, the brighter the color. Table 7 provides a reference for color versus data input.

Table 7. COLOR DATA REFERENCE

| Color       |              | Input Color Data |     |     |     |     |     |     |     |     |     |       |     |     |     |     |     |     |     |     |     |      |     |     |     |     |     |     |     |     |     |     |     |     |     |     |     |     |     |     |     |   |   |   |   |   |   |   |   |   |   |   |   |   |   |   |   |   |   |
|-------------|--------------|------------------|-----|-----|-----|-----|-----|-----|-----|-----|-----|-------|-----|-----|-----|-----|-----|-----|-----|-----|-----|------|-----|-----|-----|-----|-----|-----|-----|-----|-----|-----|-----|-----|-----|-----|-----|-----|-----|-----|-----|---|---|---|---|---|---|---|---|---|---|---|---|---|---|---|---|---|---|
|             |              | RED              |     |     |     |     |     |     |     |     |     | GREEN |     |     |     |     |     |     |     |     |     | BLUE |     |     |     |     |     |     |     |     |     |     |     |     |     |     |     |     |     |     |     |   |   |   |   |   |   |   |   |   |   |   |   |   |   |   |   |   |   |
|             |              | MSB              | MSB | MSB | MSB | MSB | MSB | MSB | MSB | MSB | MSB | LSB   | LSB | LSB | LSB | LSB | LSB | LSB | LSB | LSB | LSB | MSB  | MSB | MSB | MSB | MSB | MSB | MSB | MSB | MSB | MSB | LSB | LSB | LSB | LSB | LSB | LSB | LSB | LSB | LSB | LSB |   |   |   |   |   |   |   |   |   |   |   |   |   |   |   |   |   |   |
| R9          | R8           | R7               | R6  | R5  | R4  | R3  | R2  | R1  | R0  | G9  | G8  | G7    | G6  | G5  | G4  | G3  | G2  | G1  | G0  | B9  | B8  | B7   | B6  | B5  | B4  | B3  | B2  | B1  | B0  |     |     |     |     |     |     |     |     |     |     |     |     |   |   |   |   |   |   |   |   |   |   |   |   |   |   |   |   |   |   |
| Basic Color | Black        | 0                | 0   | 0   | 0   | 0   | 0   | 0   | 0   | 0   | 0   | 0     | 0   | 0   | 0   | 0   | 0   | 0   | 0   | 0   | 0   | 0    | 0   | 0   | 0   | 0   | 0   | 0   | 0   | 0   | 0   | 0   | 0   | 0   | 0   | 0   | 0   | 0   | 0   | 0   | 0   | 0 | 0 | 0 | 0 | 0 | 0 | 0 | 0 | 0 | 0 | 0 | 0 | 0 | 0 | 0 | 0 | 0 |   |
|             | Red (1023)   | 1                | 1   | 1   | 1   | 1   | 1   | 1   | 1   | 1   | 1   | 1     | 1   | 1   | 1   | 1   | 1   | 1   | 1   | 1   | 1   | 0    | 0   | 0   | 0   | 0   | 0   | 0   | 0   | 0   | 0   | 0   | 0   | 0   | 0   | 0   | 0   | 0   | 0   | 0   | 0   | 0 | 0 | 0 | 0 | 0 | 0 | 0 | 0 | 0 | 0 | 0 | 0 | 0 | 0 | 0 | 0 | 0 |   |
|             | Green (1023) | 0                | 0   | 0   | 0   | 0   | 0   | 0   | 0   | 0   | 0   | 0     | 0   | 0   | 0   | 0   | 0   | 0   | 0   | 0   | 0   | 1    | 1   | 1   | 1   | 1   | 1   | 1   | 1   | 1   | 1   | 1   | 1   | 1   | 1   | 1   | 1   | 1   | 1   | 1   | 0   | 0 | 0 | 0 | 0 | 0 | 0 | 0 | 0 | 0 | 0 | 0 | 0 | 0 | 0 | 0 | 0 | 0 |   |
|             | Blue (1023)  | 0                | 0   | 0   | 0   | 0   | 0   | 0   | 0   | 0   | 0   | 0     | 0   | 0   | 0   | 0   | 0   | 0   | 0   | 0   | 0   | 0    | 0   | 0   | 0   | 0   | 0   | 0   | 0   | 0   | 0   | 0   | 0   | 0   | 0   | 0   | 0   | 0   | 0   | 0   | 1   | 1 | 1 | 1 | 1 | 1 | 1 | 1 | 1 | 1 | 1 | 1 | 1 | 1 | 1 | 1 | 1 | 1 | 1 |
|             | Cyan         | 0                | 0   | 0   | 0   | 0   | 0   | 0   | 0   | 0   | 0   | 0     | 0   | 0   | 0   | 0   | 0   | 0   | 0   | 0   | 0   | 1    | 1   | 1   | 1   | 1   | 1   | 1   | 1   | 1   | 1   | 1   | 1   | 1   | 1   | 1   | 1   | 1   | 1   | 1   | 1   | 1 | 1 | 1 | 1 | 1 | 1 | 1 | 1 | 1 | 1 | 1 | 1 | 1 | 1 | 1 | 1 | 1 | 1 |
|             | Magenta      | 1                | 1   | 1   | 1   | 1   | 1   | 1   | 1   | 1   | 1   | 1     | 1   | 1   | 1   | 1   | 1   | 1   | 1   | 1   | 1   | 0    | 0   | 0   | 0   | 0   | 0   | 0   | 0   | 0   | 0   | 0   | 0   | 0   | 0   | 0   | 0   | 0   | 0   | 0   | 1   | 1 | 1 | 1 | 1 | 1 | 1 | 1 | 1 | 1 | 1 | 1 | 1 | 1 | 1 | 1 | 1 | 1 | 1 |
|             | Yellow       | 1                | 1   | 1   | 1   | 1   | 1   | 1   | 1   | 1   | 1   | 1     | 1   | 1   | 1   | 1   | 1   | 1   | 1   | 1   | 1   | 1    | 1   | 1   | 1   | 1   | 1   | 1   | 1   | 1   | 1   | 1   | 1   | 1   | 1   | 1   | 1   | 1   | 1   | 1   | 0   | 0 | 0 | 0 | 0 | 0 | 0 | 0 | 0 | 0 | 0 | 0 | 0 | 0 | 0 | 0 | 0 | 0 | 0 |
|             | White        | 1                | 1   | 1   | 1   | 1   | 1   | 1   | 1   | 1   | 1   | 1     | 1   | 1   | 1   | 1   | 1   | 1   | 1   | 1   | 1   | 1    | 1   | 1   | 1   | 1   | 1   | 1   | 1   | 1   | 1   | 1   | 1   | 1   | 1   | 1   | 1   | 1   | 1   | 1   | 1   | 1 | 1 | 1 | 1 | 1 | 1 | 1 | 1 | 1 | 1 | 1 | 1 | 1 | 1 | 1 | 1 | 1 | 1 |
| RED         | RED (0000)   | 0                | 0   | 0   | 0   | 0   | 0   | 0   | 0   | 0   | 0   | 0     | 0   | 0   | 0   | 0   | 0   | 0   | 0   | 0   | 0   | 0    | 0   | 0   | 0   | 0   | 0   | 0   | 0   | 0   | 0   | 0   | 0   | 0   | 0   | 0   | 0   | 0   | 0   | 0   | 0   | 0 | 0 | 0 | 0 | 0 | 0 | 0 | 0 | 0 | 0 | 0 | 0 | 0 | 0 | 0 | 0 | 0 |   |
|             | RED (0001)   | 0                | 0   | 0   | 0   | 0   | 0   | 0   | 0   | 0   | 0   | 0     | 0   | 0   | 0   | 0   | 0   | 0   | 0   | 0   | 1   | 0    | 0   | 0   | 0   | 0   | 0   | 0   | 0   | 0   | 0   | 0   | 0   | 0   | 0   | 0   | 0   | 0   | 0   | 0   | 0   | 0 | 0 | 0 | 0 | 0 | 0 | 0 | 0 | 0 | 0 | 0 | 0 | 0 | 0 | 0 | 0 | 0 |   |
|             | ...          | ...              | ... | ... | ... | ... | ... | ... | ... | ... | ... | ...   | ... | ... | ... | ... | ... | ... | ... | ... | ... | ...  | ... | ... | ... | ... | ... | ... | ... | ... | ... | ... | ... | ... | ... | ... | ... | ... | ... |     |     |   |   |   |   |   |   |   |   |   |   |   |   |   |   |   |   |   |   |
|             | RED (1022)   | 1                | 1   | 1   | 1   | 1   | 1   | 1   | 1   | 1   | 1   | 1     | 1   | 1   | 1   | 1   | 1   | 1   | 1   | 0   | 0   | 0    | 0   | 0   | 0   | 0   | 0   | 0   | 0   | 0   | 0   | 0   | 0   | 0   | 0   | 0   | 0   | 0   | 0   | 0   | 0   | 0 | 0 | 0 | 0 | 0 | 0 | 0 | 0 | 0 | 0 | 0 | 0 | 0 | 0 | 0 | 0 |   |   |
|             | RED (1023)   | 1                | 1   | 1   | 1   | 1   | 1   | 1   | 1   | 1   | 1   | 1     | 1   | 1   | 1   | 1   | 1   | 1   | 1   | 1   | 0   | 0    | 0   | 0   | 0   | 0   | 0   | 0   | 0   | 0   | 0   | 0   | 0   | 0   | 0   | 0   | 0   | 0   | 0   | 0   | 0   | 0 | 0 | 0 | 0 | 0 | 0 | 0 | 0 | 0 | 0 | 0 | 0 | 0 | 0 | 0 | 0 | 0 |   |
| GREEN       | GREEN (0000) | 0                | 0   | 0   | 0   | 0   | 0   | 0   | 0   | 0   | 0   | 0     | 0   | 0   | 0   | 0   | 0   | 0   | 0   | 0   | 0   | 0    | 0   | 0   | 0   | 0   | 0   | 0   | 0   | 0   | 0   | 0   | 0   | 0   | 0   | 0   | 0   | 0   | 0   | 0   | 0   | 0 | 0 | 0 | 0 | 0 | 0 | 0 | 0 | 0 | 0 | 0 | 0 | 0 | 0 | 0 | 0 | 0 |   |
|             | GREEN (0001) | 0                | 0   | 0   | 0   | 0   | 0   | 0   | 0   | 0   | 0   | 0     | 0   | 0   | 0   | 0   | 0   | 0   | 0   | 0   | 1   | 0    | 0   | 0   | 0   | 0   | 0   | 0   | 0   | 0   | 0   | 0   | 0   | 0   | 0   | 0   | 0   | 0   | 0   | 0   | 0   | 0 | 0 | 0 | 0 | 0 | 0 | 0 | 0 | 0 | 0 | 0 | 0 | 0 | 0 | 0 | 0 | 0 |   |
|             | ...          | ...              | ... | ... | ... | ... | ... | ... | ... | ... | ... | ...   | ... | ... | ... | ... | ... | ... | ... | ... | ... | ...  | ... | ... | ... | ... | ... | ... | ... | ... | ... | ... | ... | ... | ... | ... | ... | ... |     |     |     |   |   |   |   |   |   |   |   |   |   |   |   |   |   |   |   |   |   |
|             | GREEN (1022) | 0                | 0   | 0   | 0   | 0   | 0   | 0   | 0   | 0   | 0   | 0     | 0   | 0   | 0   | 0   | 0   | 0   | 0   | 0   | 1   | 1    | 1   | 1   | 1   | 1   | 1   | 1   | 1   | 1   | 1   | 1   | 1   | 1   | 1   | 1   | 1   | 1   | 0   | 0   | 0   | 0 | 0 | 0 | 0 | 0 | 0 | 0 | 0 | 0 | 0 | 0 | 0 | 0 | 0 | 0 | 0 |   |   |
|             | GREEN (1023) | 0                | 0   | 0   | 0   | 0   | 0   | 0   | 0   | 0   | 0   | 0     | 0   | 0   | 0   | 0   | 0   | 0   | 0   | 0   | 1   | 1    | 1   | 1   | 1   | 1   | 1   | 1   | 1   | 1   | 1   | 1   | 1   | 1   | 1   | 1   | 1   | 1   | 1   | 0   | 0   | 0 | 0 | 0 | 0 | 0 | 0 | 0 | 0 | 0 | 0 | 0 | 0 | 0 | 0 | 0 | 0 | 0 |   |
| BLUE        | BLUE (0000)  | 0                | 0   | 0   | 0   | 0   | 0   | 0   | 0   | 0   | 0   | 0     | 0   | 0   | 0   | 0   | 0   | 0   | 0   | 0   | 0   | 0    | 0   | 0   | 0   | 0   | 0   | 0   | 0   | 0   | 0   | 0   | 0   | 0   | 0   | 0   | 0   | 0   | 0   | 0   | 0   | 0 | 0 | 0 | 0 | 0 | 0 | 0 | 0 | 0 | 0 | 0 | 0 | 0 | 0 | 0 | 0 | 0 |   |
|             | BLUE (0001)  | 0                | 0   | 0   | 0   | 0   | 0   | 0   | 0   | 0   | 0   | 0     | 0   | 0   | 0   | 0   | 0   | 0   | 0   | 0   | 0   | 0    | 0   | 0   | 0   | 0   | 0   | 0   | 0   | 0   | 0   | 0   | 0   | 0   | 0   | 0   | 0   | 0   | 0   | 0   | 0   | 0 | 0 | 0 | 0 | 0 | 0 | 0 | 0 | 0 | 0 | 0 | 0 | 0 | 0 | 0 | 0 | 0 | 1 |
|             | ...          | ...              | ... | ... | ... | ... | ... | ... | ... | ... | ... | ...   | ... | ... | ... | ... | ... | ... | ... | ... | ... | ...  | ... | ... | ... | ... | ... | ... | ... | ... | ... | ... | ... | ... | ... | ... | ... | ... | ... |     |     |   |   |   |   |   |   |   |   |   |   |   |   |   |   |   |   |   |   |
|             | BLUE (1022)  | 0                | 0   | 0   | 0   | 0   | 0   | 0   | 0   | 0   | 0   | 0     | 0   | 0   | 0   | 0   | 0   | 0   | 0   | 0   | 0   | 0    | 0   | 0   | 0   | 0   | 0   | 0   | 0   | 0   | 0   | 0   | 0   | 0   | 0   | 0   | 0   | 0   | 0   | 1   | 1   | 1 | 1 | 1 | 1 | 1 | 1 | 1 | 1 | 1 | 1 | 1 | 1 | 1 | 1 | 1 | 1 | 0 |   |
|             | BLUE (1023)  | 0                | 0   | 0   | 0   | 0   | 0   | 0   | 0   | 0   | 0   | 0     | 0   | 0   | 0   | 0   | 0   | 0   | 0   | 0   | 0   | 0    | 0   | 0   | 0   | 0   | 0   | 0   | 0   | 0   | 0   | 0   | 0   | 0   | 0   | 0   | 0   | 0   | 0   | 1   | 1   | 1 | 1 | 1 | 1 | 1 | 1 | 1 | 1 | 1 | 1 | 1 | 1 | 1 | 1 | 1 | 1 | 1 |   |

## Product Specification

## 3-6. Power Sequence

## 3-6-1. LCD Driving circuit

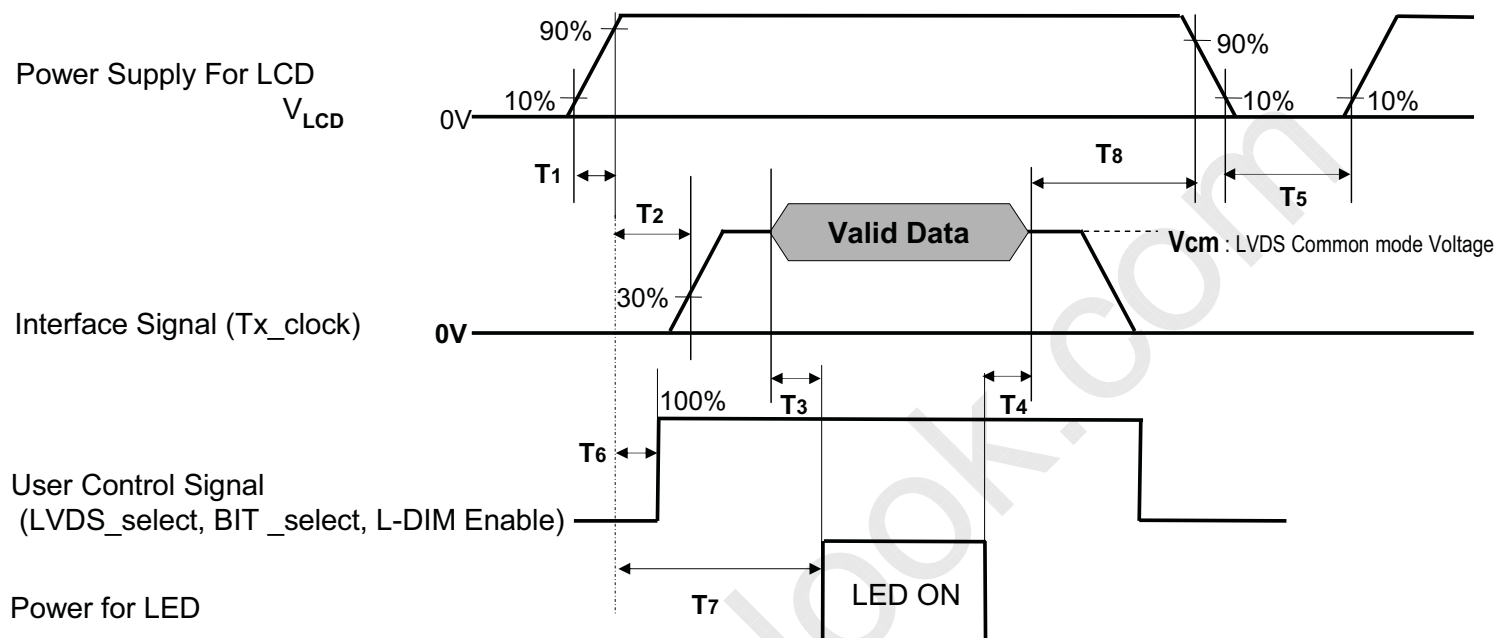

Table 8. POWER SEQUENCE

| Parameter | Value |     |     | Unit | Notes |
|-----------|-------|-----|-----|------|-------|
|           | Min   | Typ | Max |      |       |
| T1        | 0.5   | -   | 20  | ms   | 1     |
| T2        | 0     | -   | -   | ms   | 2     |
| T3        | 200   | -   | -   | ms   | 3     |
| T4        | 200   | -   | -   | ms   | 3     |
| T5        | 1.0   | -   | -   | s    | 4     |
| T6        | -     | -   | T2  | ms   | 5     |
| T7        | 0.5   | -   | -   | s    | 6     |
| T8        | 100   | -   | -   | ms   | 7     |

- Note :
1. Even though T1 is over the specified value, there is no problem if I2T spec of fuse is satisfied.
  2. If T2 is satisfied with specification after removing LVDS Cable, there is no problem.
  3. The T3 / T4 is recommended value, the case when failed to meet a minimum specification, abnormal display would be shown. There is no reliability problem.
  4. T5 should be measured after the Module has been fully discharged between power off and on period.
  5. If the on time of signals (Interface signal and user control signals) precedes the on time of Power ( $V_{LCD}$ ), it will be happened abnormal display. When T6 is NC status, T6 doesn't need to be measured.
  6. If there is no abnormal display, no problem.
  7. It is recommendation specification that T8 has to be 100ms as a minimum value.
    - ※ Please avoid floating state of interface signal at invalid period.
    - ※ When the power supply for LCD ( $V_{LCD}$ ) is off, be sure to pull down the valid and invalid data to 0V.



## Product Specification

## 3-6-2. Sequence for LED Driver

## Power Supply For LED Driver

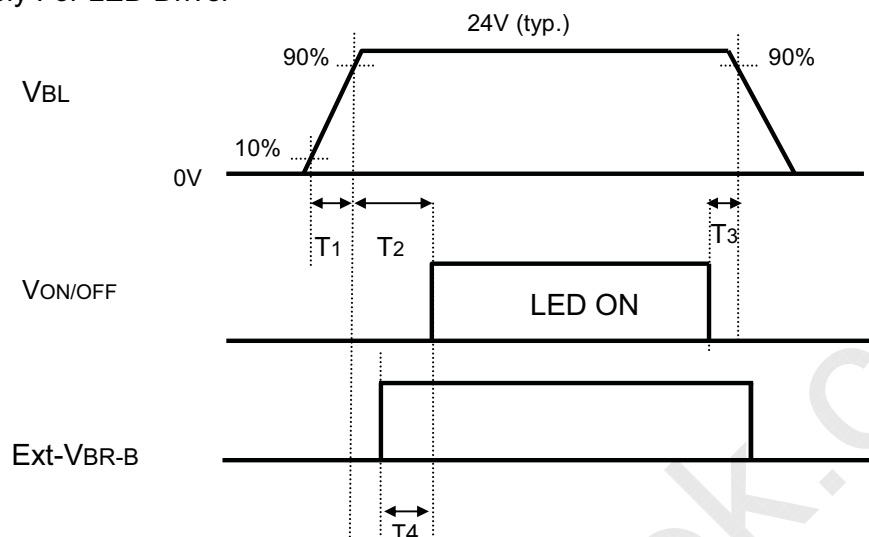

## 3-6-3. Dip condition for LED Driver

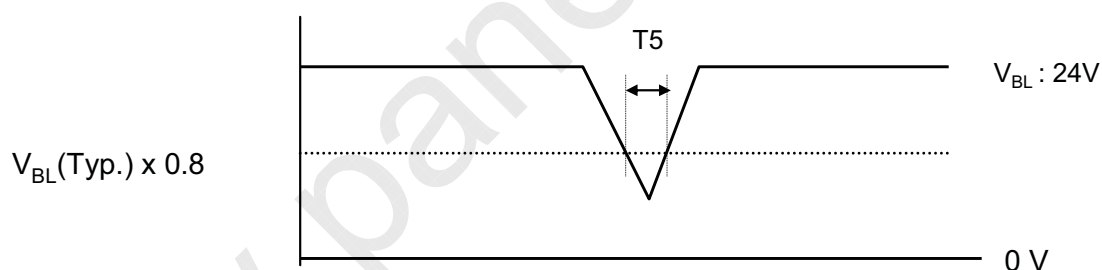

Table 9. Power Sequence for LED Driver

| Parameter | Values |     |     | Units | Remarks                   |
|-----------|--------|-----|-----|-------|---------------------------|
|           | Min    | Typ | Max |       |                           |
| T1        | 20     | -   | -   | ms    | 1                         |
| T2        | 500    | -   | -   | ms    |                           |
| T3        | 10     | -   | -   | ms    |                           |
| T4        | 0      | -   | -   | ms    |                           |
| T5        | -      | -   | 10  | ms    | $V_{BL}(Typ.) \times 0.8$ |

Notes : 1. T1 describes rising time of 0V to 24V and this parameter does not applied at restarting time.  
Even though T1 is over the specified value, there is no problem if I<sup>2</sup>T spec of fuse is satisfied.

## Product Specification

## 4. Optical Specification

Optical characteristics are determined after the unit has been 'ON' and stable in a dark environment at  $25\pm 2^{\circ}\text{C}$ . The values are specified at distance 50cm from the LCD surface at a viewing angle of  $\Phi$  and  $\theta$  equal to  $0^{\circ}$ . FIG. 1 shows additional information concerning the measurement equipment and method.

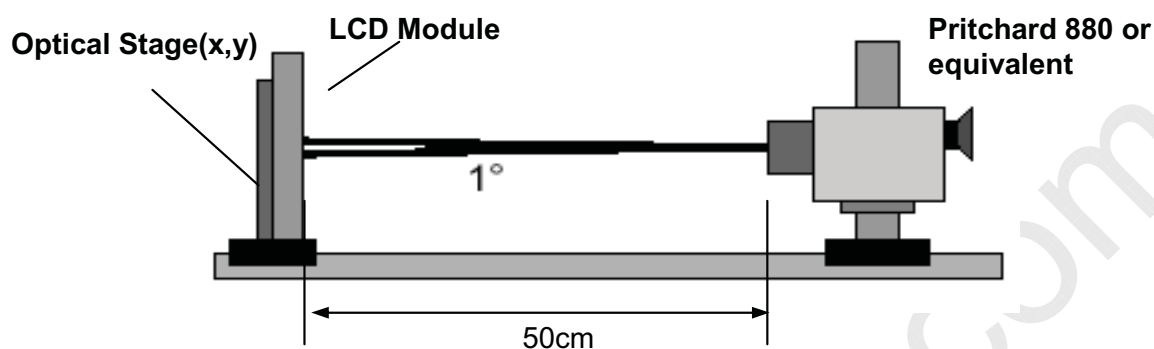

FIG. 1 Optical Characteristic Measurement Equipment and Method

Table 10. OPTICAL CHARACTERISTICS

$T_a = 25\pm 2^{\circ}\text{C}$ ,  $V_{\text{LCD}} = 12.0\text{V}$ ,  $f_v = 120\text{Hz}$ ,  $D_{\text{clk}} = 74.25\text{MHz}$ ,  
EXTVBR-B = 100%

| Parameter                      | Symbol                  | Value                      |  |            | Unit              | Note |        |   |
|--------------------------------|-------------------------|----------------------------|--|------------|-------------------|------|--------|---|
|                                |                         | Min                        | Typ  | Max        |                   |      |        |   |
| Contrast Ratio                 | CR                      | 1200                       | 1600   | -          |                   | 1    |        |   |
| Surface Luminance, white       | $L_{\text{WH}}$         | 2D                         | 320  | 400        | cd/m <sup>2</sup> | 2    |        |   |
|                                |                         | 3D                         | 120  | 150        |                   | 7    |        |   |
| Luminance Variation            | $\delta_{\text{WHITE}}$ |                            |  | 1.3        |                   | 3    |        |   |
| Response Time                  | Gray-to-Gray            | G to G                     | -  | 5          | ms                | 4    |        |   |
|                                | MPRT                    | MPRT                       | -  | 8          |                   | 5    |        |   |
|                                | Uniformity              | $\delta_{\text{MPRT}}$     | -  | -          |                   | 1    | 5      |   |
|                                | Uniformity              | $\delta_{\text{G TO G}}$   | -  | -          |                   | 1    | 5      |   |
| Color Coordinates<br>[CIE1931] | RED                     | Rx                         | Typ<br>-0.03                                 | 0.633(TBD) | Typ<br>+0.03      |      |        |   |
|                                |                         | Ry                         |  | 0.343(TBD) |                   |      |        |   |
|                                | GREEN                   | Gx                         |  | 0.318(TBD) |                   |      |        |   |
|                                |                         | Gy                         |  | 0.608(TBD) |                   |      |        |   |
|                                | BLUE                    | Bx                         |  | 0.155(TBD) |                   |      |        |   |
|                                |                         | By                         |  | 0.056(TBD) |                   |      |        |   |
|                                | WHITE                   | Wx                         |  | 0.279      |                   |      |        |   |
|                                |                         | Wy                         |  | 0.292      |                   |      |        |   |
| Color Temperature              |                         |                            | 10,000                                       |            | K                 |      |        |   |
| Color Gamut                    |                         |                            | 72   |            | %                 |      |        |   |
| Viewing Angle                  | 2D<br>(CR>10)           | right( $\phi=0^{\circ}$ )  | $\theta_r$ (x axis)                          | 89         | -                 | -    | degree | 6 |
|                                |                         | left( $\phi=180^{\circ}$ ) | $\theta_l$ (x axis)                          | 89         | -                 | -    |        |   |
|                                |                         | up( $\phi=90^{\circ}$ )    | $\theta_u$ (y axis)                          | 89         | -                 | -    |        |   |
|                                |                         | down( $\phi=270^{\circ}$ ) | $\theta_d$ (y axis)                          | 89         | -                 | -    |        |   |
|                                | 3D<br>(CT $\leq$ 10%)   | up + down                  | $\theta_u$ (y axis)<br>+ $\theta_d$ (y axis) | 22         | 26                | -    | degree | 8 |
| 3D Crosstalk                   | 3D C/T                  |                            | 1  | 3          | %                 | 7    |        |   |
| Gray Scale                     |                         |                            | -  | -          | -                 |      | 7      |   |

## Product Specification

Note : 1. Contrast Ratio(CR) is defined mathematically as :

$$\text{Contrast Ratio} = \frac{\text{Surface Luminance with all white pixels}}{\text{Surface Luminance with all black pixels}}$$

It is measured at center 1-point.

2. Surface luminance is determined after the unit has been 'ON' and 1 Hour after lighting the backlight in a dark environment at  $25 \pm 2^\circ\text{C}$ . Surface luminance is the luminance value at center 1-point across the LCD surface 50cm from the surface with all pixels displaying white. For more information see the FIG. 2.
3. The variation in surface luminance,  $\delta$  WHITE is defined as :  
 $\delta$  WHITE(5P) = Maximum( $L_{on1}, L_{on2}, L_{on3}, L_{on4}, L_{on5}$ ) / Minimum( $L_{on1}, L_{on2}, L_{on3}, L_{on4}, L_{on5}$ )  
 Where  $L_{on1}$  to  $L_{on5}$  are the luminance with all pixels displaying white at 5 locations .  
 For more information, see the FIG. 2.
4. Response time is the time required for the display to transit from G(N) to G(M) (Rise Time,  $Tr_R$ ) and from G(M) to G(N) (Decay Time,  $Tr_D$ ). For additional information see the FIG. 3. (N<M)  
 ※ G to G Spec stands for average value of all measured points.  
 Photo Detector : RD-80S / Field :  $2^\circ$
5. MPRT is defined as the 10% to 90% blur-edge width  $B_{ij}$ (pixels) and scroll speed  $U$ (pixels/frame)at the moving picture. For more information, see FIG 4  
 ※. Gray to Gray / MPRT Response time uniformity is Reference data. Appendix VII-1/ VII-2
6. Viewing angle is the angle at which the contrast ratio is greater than 10. The angles are determined for the horizontal or x axis and the vertical or y axis with respect to the z axis which is normal to the LCD module surface. For more information, see the FIG. 5.
7. Gray scale specification  
 Gamma Value is approximately 2.2. For more information, see the Table 11.
8. 3D performance specification is expressed by 3D luminance, 3D Crosstalk and 3D viewing angle. 3D luminance and 3D crosstalk is measured at center 1-point.  
 For more information, see the FIG 6~8.

**Table 11. GRAY SCALE SPECIFICATION**

| Gray Level | Luminance [%] (Typ) |
|------------|---------------------|
| L0         | 0.063               |
| L63        | 0.27                |
| L127       | 1.04                |
| L191       | 2.49                |
| L255       | 4.68                |
| L319       | 7.66                |
| L383       | 11.5                |
| L447       | 16.1                |
| L511       | 21.6                |
| L575       | 28.1                |
| L639       | 35.4                |
| L703       | 43.7                |
| L767       | 53.0                |
| L831       | 63.2                |
| L895       | 74.5                |
| L959       | 86.7                |
| L1023      | 100                 |

Product Specification

Measuring point for surface luminance & measuring point for luminance variation.

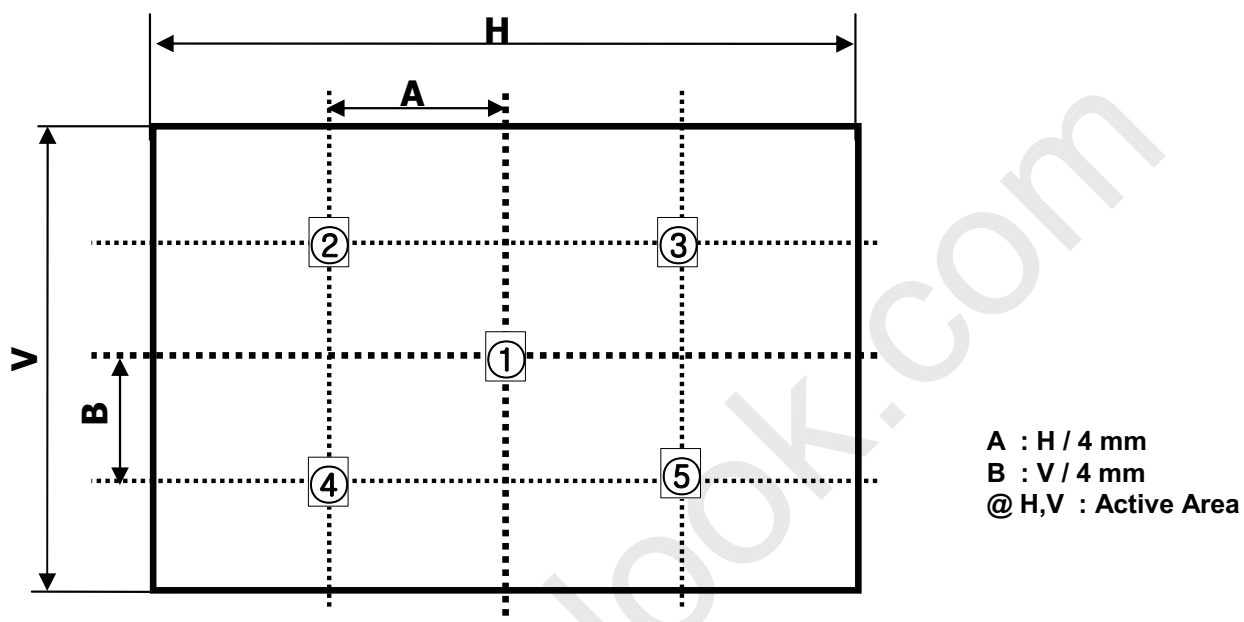

FIG. 2 5 Points for Luminance Measure

Response time is defined as the following figure and shall be measured by switching the input signal for "Gray(N)" and "Gray(M)".

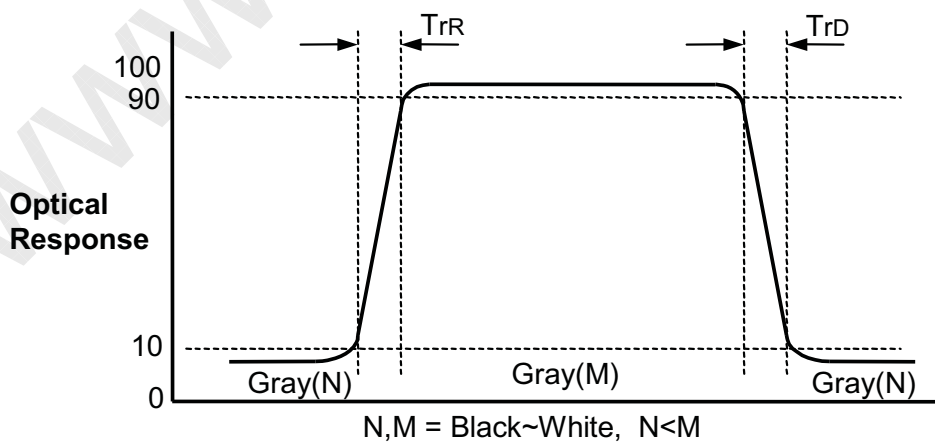
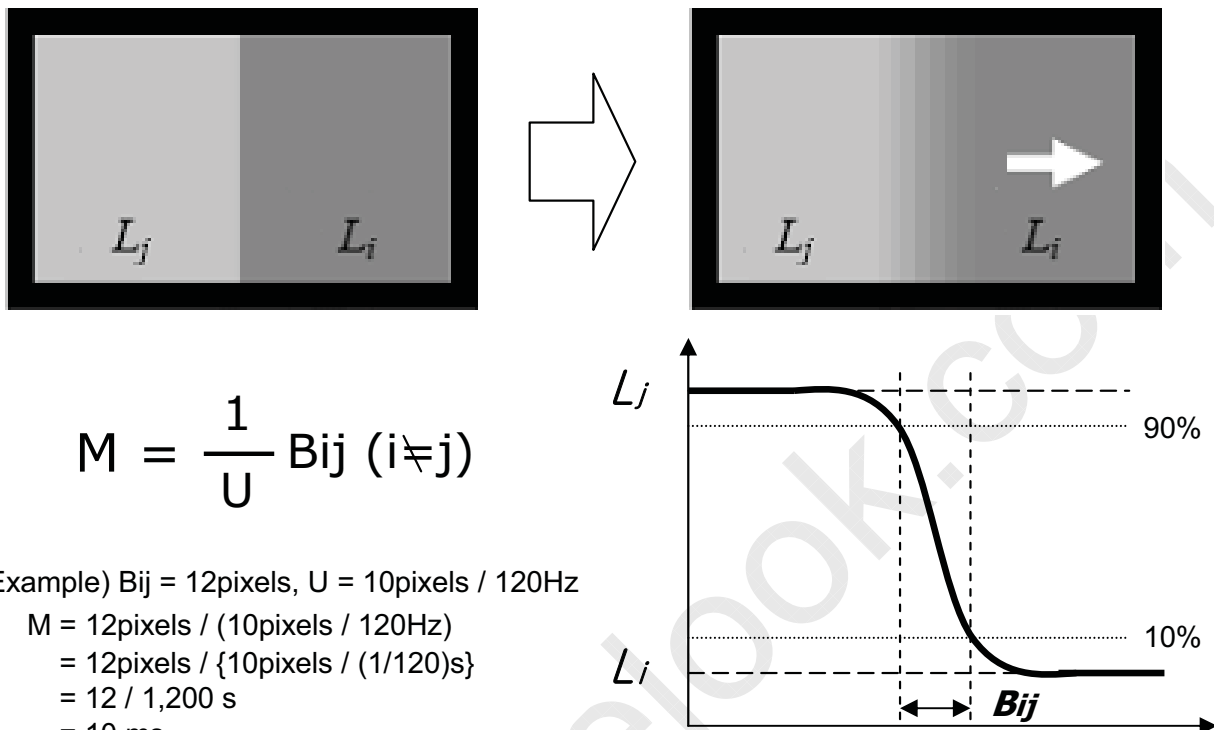

FIG. 3 Response Time

Product Specification

MPRT is defined as the 10% to 90% blur-edge with  $B_{ij}$ (pixels) and scroll speed  $U$ (pixels/frame)at the moving picture.



$$M = \frac{1}{U} B_{ij} \quad (i \neq j)$$

Example)  $B_{ij} = 12\text{pixels}$ ,  $U = 10\text{pixels} / 120\text{Hz}$   
 $M = 12\text{pixels} / (10\text{pixels} / 120\text{Hz})$   
 $= 12\text{pixels} / \{10\text{pixels} / (1/120)\text{s}\}$   
 $= 12 / 1,200 \text{ s}$   
 $= 10 \text{ ms}$

FIG. 4 MPRT

Dimension of viewing angle range

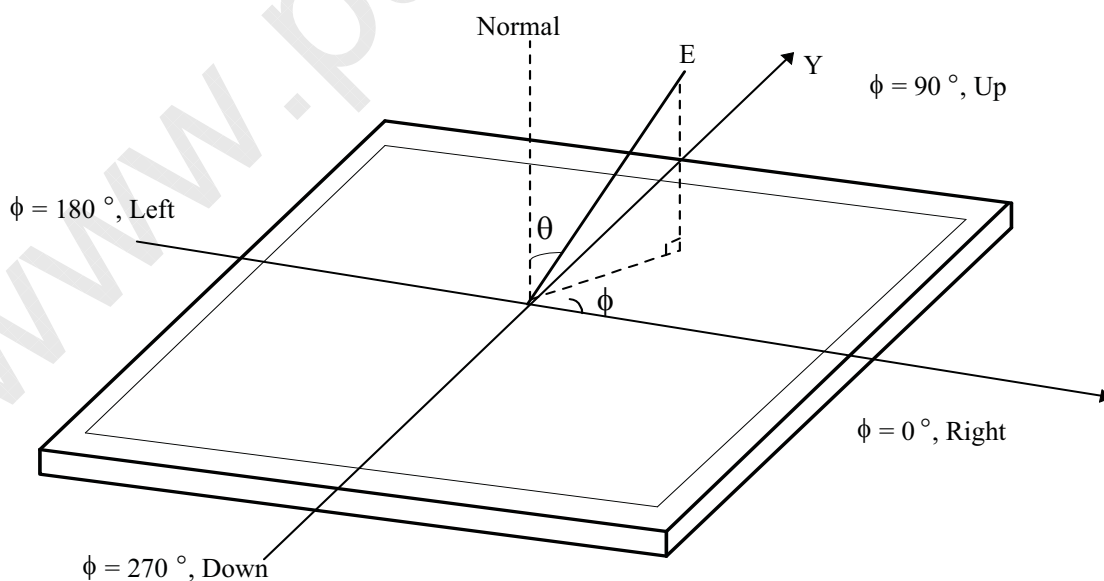

FIG. 5 Viewing Angle

## Product Specification

## Image sticking

When it changes into pattern-B after a 1-hour drive by pattern-A, it disappears within 10 minutes.

&lt;Pattern-A, Chess board (8x6)&gt;

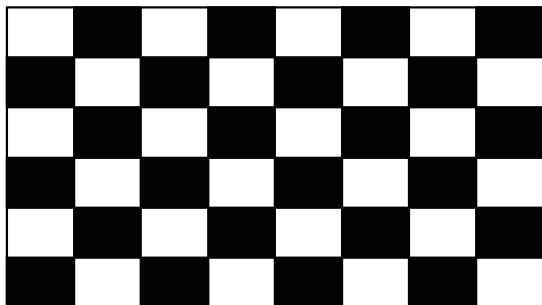

&lt;Pattern-B, Mid-gray(511 gray)&gt;

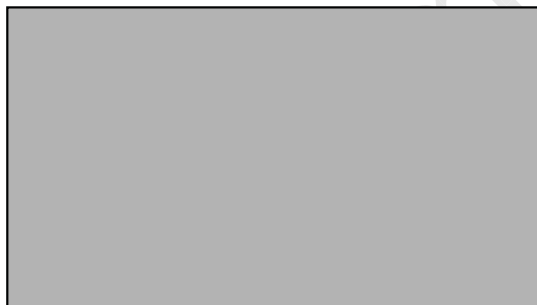

## Product Specification

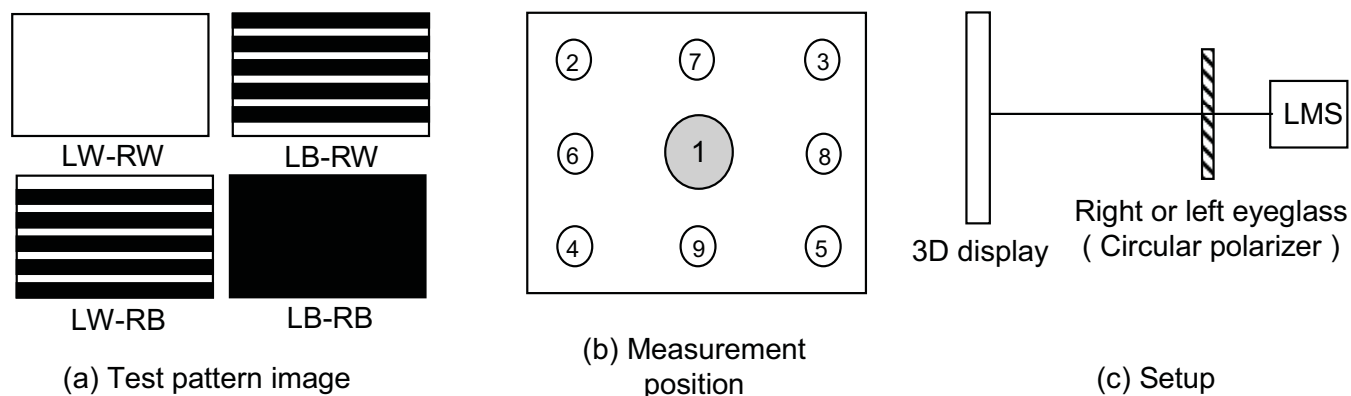

&lt; FIG.6. Measurement configuration &gt;

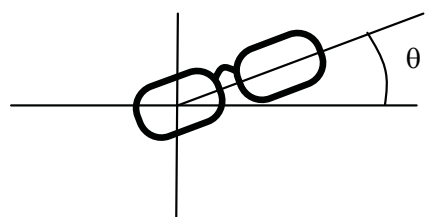

&lt; FIG.7. Positioning eyeglass &gt;

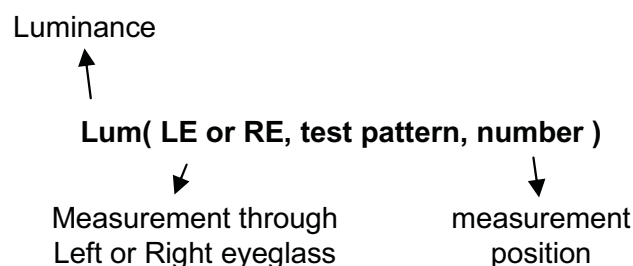

&lt; FIG. 8. notation of luminance measurement &gt;

In order to measure 3D luminance, 3D crosstalk and 3D viewing angle, it need to be prepared as below;

## 1) Measurement configuration

4-Test pattern images. Refer to FIG 8.

- . LW-RW : White for left and right eye
- . LW-RB : White for left eye and Black for right eye
- . LB-RW : Black for left eye and white for right eye
- . LB-RB : Black for left eye and right eye

Image files where black and white lines are displayed on even or odd lines.

Luminance measurement system (LMS) with narrow FOV (field of view) is used. Refer to FIG 1.

## 2) Positioning Eyeglass (refer to appendix-VIII for standard specification of eyeglass)

Find angle of minimum transmittance.

This value would be provided beforehand or measured by the following steps;

- (i) Test image (LB-RW) is displayed.
- (ii) Left eyeglass are placed in front of LMS and luminance is measured, rotating right eyeglass such as FIG 7. The notation for luminance measurement is "Lum(LE, LB-RW,1)".
- (iii) Find the angle where luminance is minimum.

\* Following measurements should be performed at the angle of minimum transmittance of eyeglass.

## Product Specification

## 3) Measurement of 3D luminance

- (i) Test image ( LW-RW ) is displayed.
- (ii) Left or right eyeglass are placed in front of LMS successively and luminance is measured at center 1 point where the notation for luminance measurement is "Lum(LE, LW-RW,1)" or "Lum(RE, LW-RW,1).

## 4) Measurement of 3D crosstalk

- (i) Test image ( LB-RW, LW-RB and LB-RB ) is displayed.
- (ii) Right or left eyeglass are placed in front of LMS successively and luminance is measured for position 1. with rotating LMS or sample vertically.

$$\frac{\text{Lum}(\text{LE}, \text{LB-RW}, 1) - \text{Lum}(\text{LE}, \text{LB-RB}, 1)}{\text{Lum}(\text{LE}, \text{LW-RB}, 1) - \text{Lum}(\text{LE}, \text{LB-RB}, 1)}$$

or

$$\frac{\text{Lum}(\text{RE}, \text{LW-RB}, 1) - \text{Lum}(\text{RE}, \text{LB-RB}, 1)}{\text{Lum}(\text{RE}, \text{LB-RW}, 1) - \text{Lum}(\text{RE}, \text{LB-RB}, 1)}$$

## 5) Measurement of 3D Viewing Angle

3D viewing angle is the angle at which the 3D crosstalk is under 10%. The angles are determined for the vertical or y axis with respect to the z axis which is normal to the LCD module surface and measured for position 1. For more information , see the Fig 9

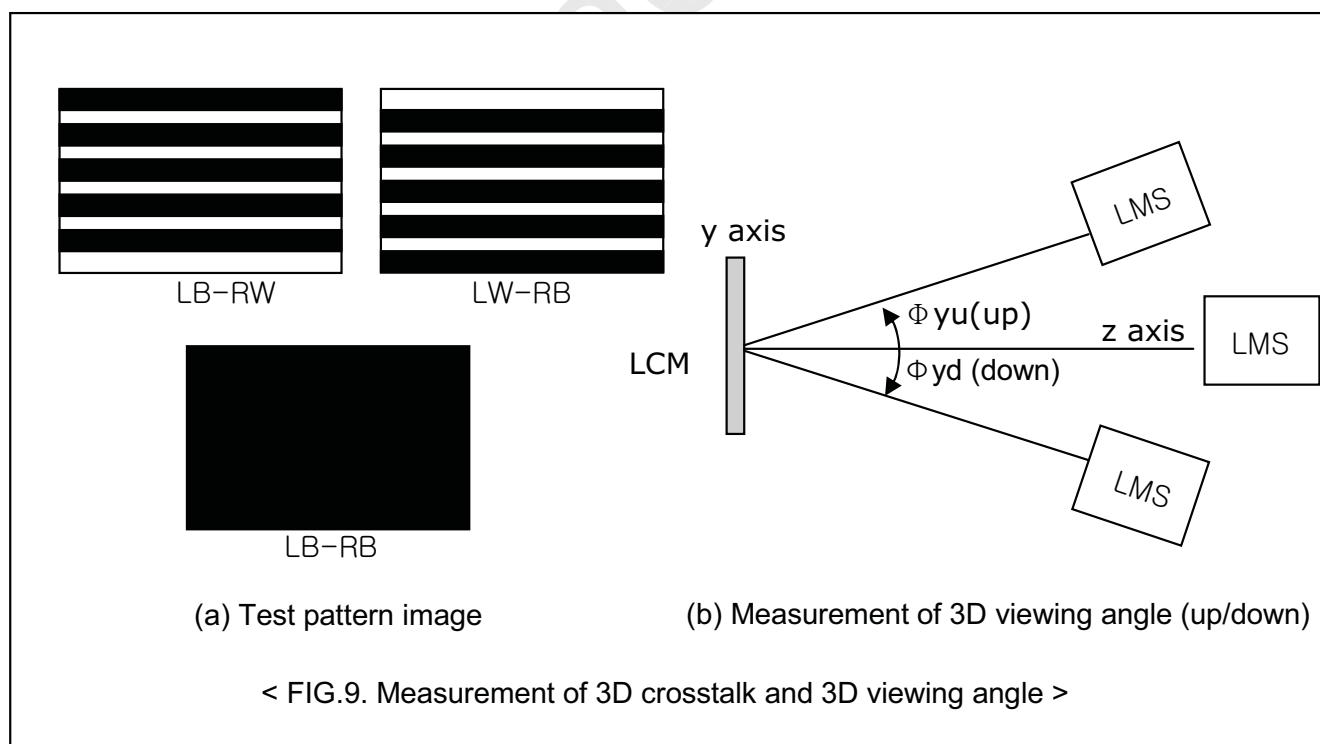



## Product Specification

**5. Mechanical Characteristics**

Table 12 provides general mechanical characteristics.

**Table 12. MECHANICAL CHARACTERISTICS**

| Item                | Value                                    |                    |
|---------------------|--|--------------------|
| Outline Dimension   | Horizontal                               | 1070.6 mm          |
|                     | Vertical                                 | 622.0 mm           |
|                     | Depth                                    | 9.9(B) / 23.1(D)mm |
| Bezel Area          | Horizontal                               | 1048.8 mm          |
|                     | Vertical                                 | 593.1 mm           |
| Active Display Area | Horizontal                               | 1039.68 mm         |
|                     | Vertical                                 | 584.82 mm          |
| Weight              | 10.9(TBD) Kg (Typ.),11.6 (TBD) kg (Max.) |                    |

Note : Please refer to a mechanical drawing in terms of tolerance at the next page.

Product Specification

[ FRONT VIEW ]

Set : Top

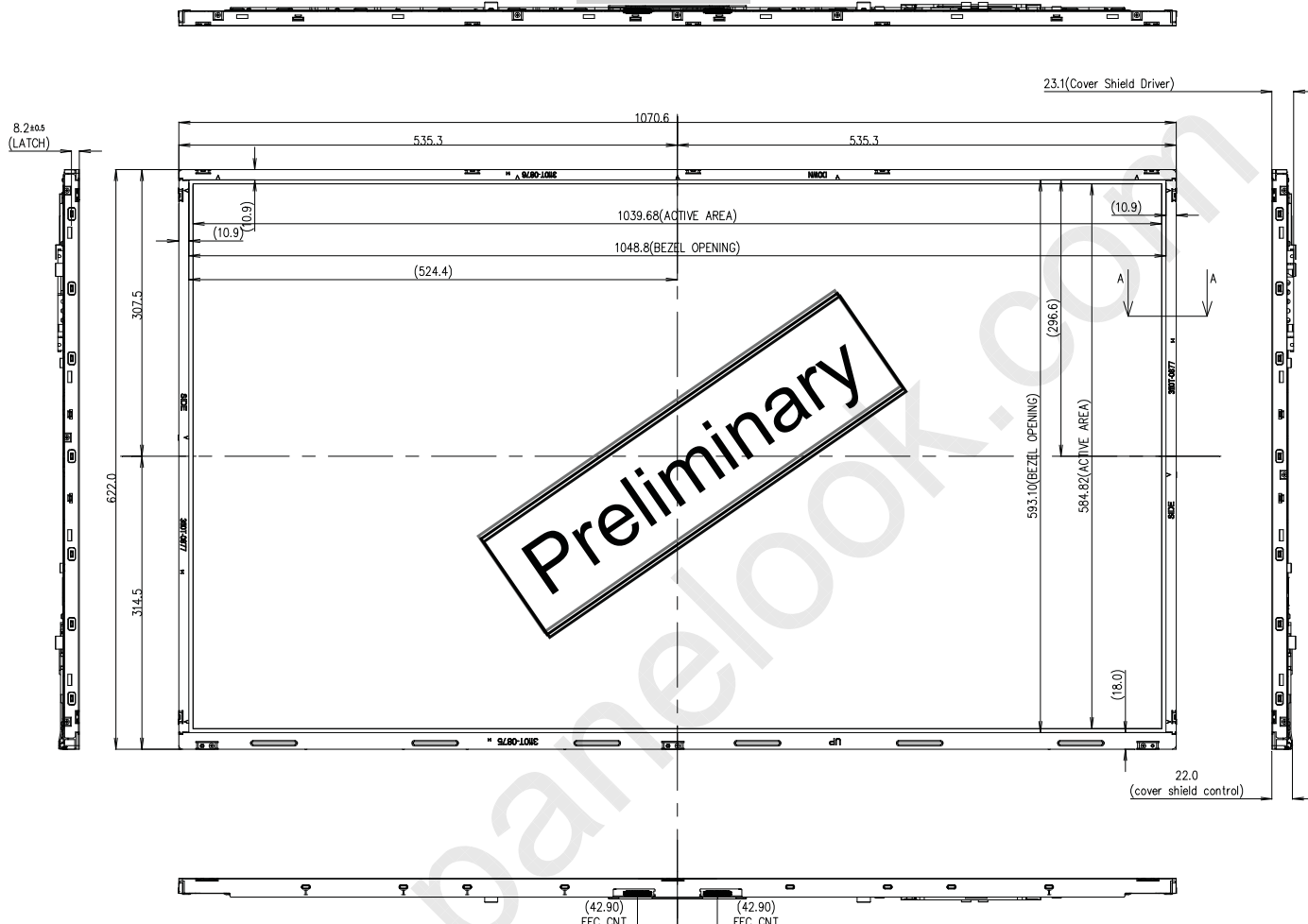

Set : Down

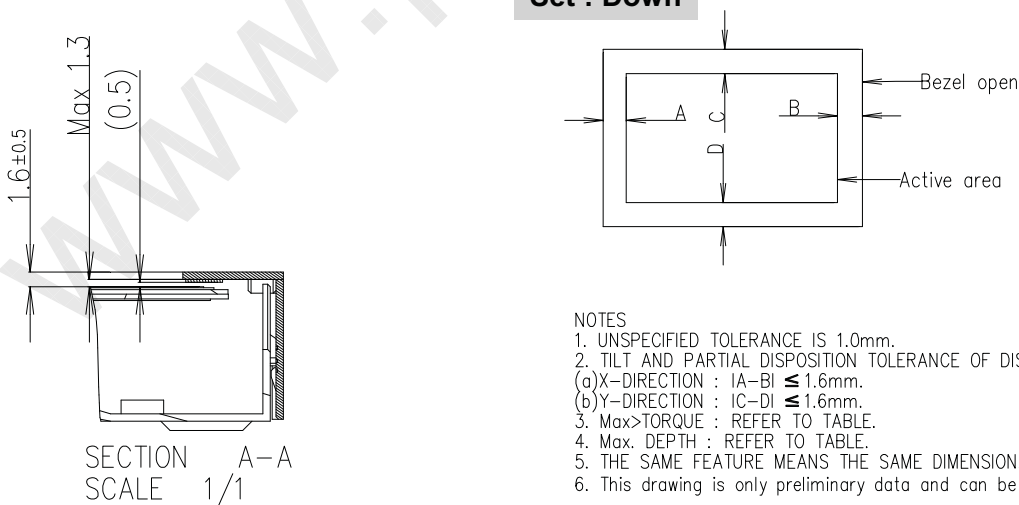

- NOTES
1. UNSPECIFIED TOLERANCE IS 1.0mm.
  2. TILT AND PARTIAL DISPOSITION TOLERANCE OF DISPLAY AREA AS FOLLOWING.  
 (a) X-DIRECTION : IA-BI ≤ 1.6mm.  
 (b) Y-DIRECTION : IC-DI ≤ 1.6mm.
  3. Max>TORQUE : REFER TO TABLE.
  4. Max. DEPTH : REFER TO TABLE.
  5. THE SAME FEATURE MEANS THE SAME DIMENSION.
  6. This drawing is only preliminary data and can be changed.

Product Specification

[ REAR VIEW ]

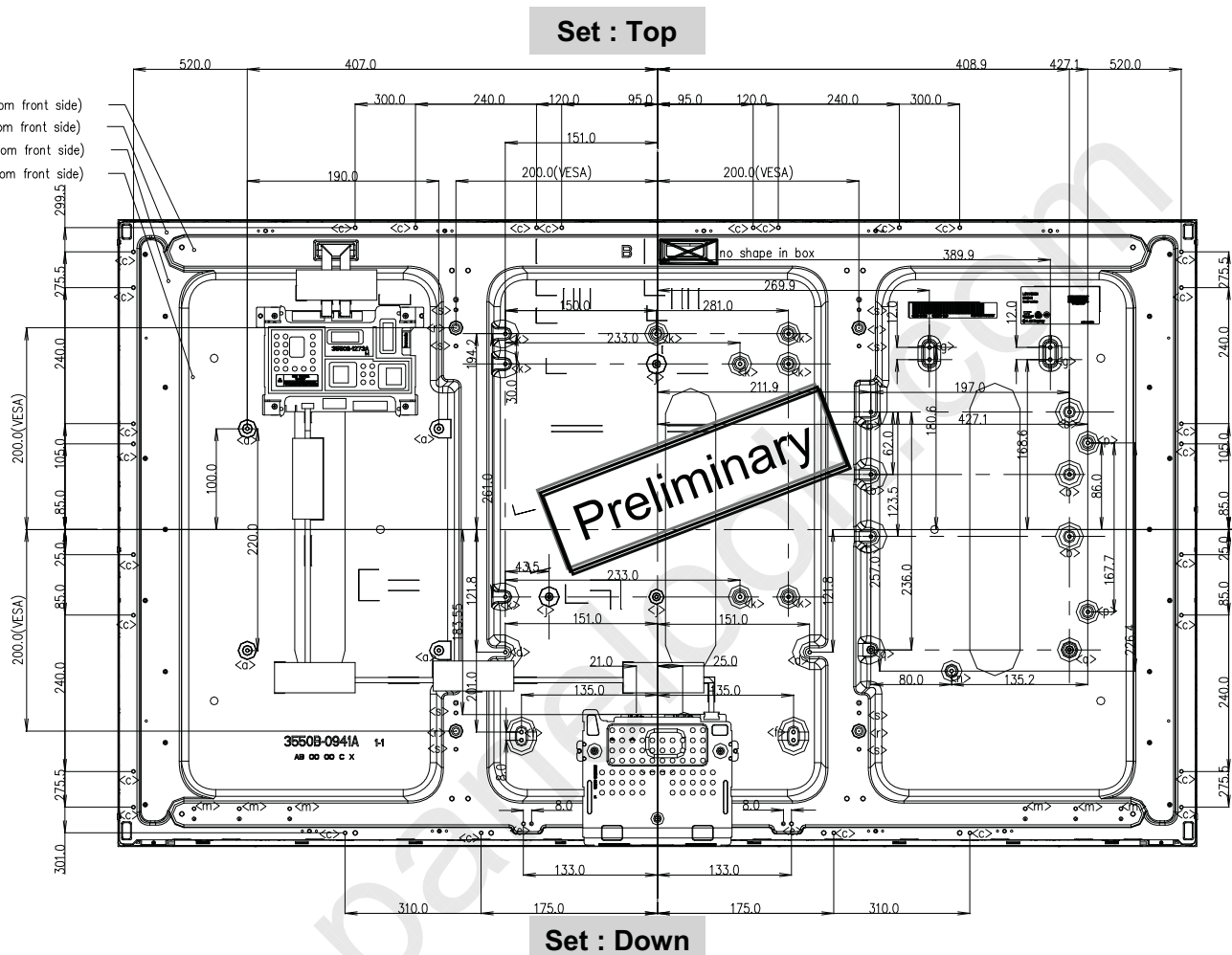

| ITEM | TAP | Max Depth (mm) | Torque (Kgf.cm) | Notes |
|------|-----|----------------|-----------------|-------|
| <a>  | M3  | 10             | MAX 8.0         |       |
| <b>  | M3  | 6              | MAX 8.0         |       |
| <c>  | M3  | 5              | MAX 8.0         |       |
| <d>  | M3  | 7              | MAX 8.0         |       |
| <e>  | M3  | 7              | MAX 8.0         |       |
| <f>  | M4  | 7              | MAX 8.0         |       |
| <g>  | M3  | 3.5            | MAX 8.0         |       |
| <j>  | M3  | 3.5            | MAX 8.0         |       |
| <k>  | M3  | 3.5            | MAX 8.0         |       |
| <m>  | M3  | 7.0            | MAX 8.0         |       |
| <n>  | M3  | 2.0            | MAX 8.0         |       |
| <p>  | M3  | 3.5            | MAX 8.0         |       |
| <q>  | M3  | 6.0            | MAX 8.0         |       |
| <r>  | M6  | 12.0           | MAX 15.0        |       |
| <s>  | M3  | 7              | MAX 8.0         |       |

## Product Specification

## 6. Reliability

Table 13. ENVIRONMENT TEST CONDITION

| No. | Test Item                                | Condition  |
|-----|--|--|
| 1   | High temperature storage test            | Ta= 60°C 240h  |
| 2   | Low temperature storage test             | Ta= -20°C 240h   |
| 3   | High temperature operation test          | Ta= 50°C 50%RH 240h  |
| 4   | Low temperature operation test           | Ta= 0°C 240h   |
| 5   | Vibration test<br>(non-operating)        | Wave form : random<br>Vibration level : 1.0Grms<br>Bandwidth : 10-300Hz<br>Duration : X,Y,Z,<br>Each direction per 10 min                    |
| 6   | Shock test<br>(non-operating)            | Shock level : 50G(X,Y axisTBD) 35G(Z axis TBD ) Grms<br>Waveform : half sine wave, 11ms<br>Direction : ±X, ±Y, ±Z<br>One time each direction |
| 7   | Humidity condition Operation             | Ta= 40 °C ,90%RH   |
| 8   | Altitude operating<br>storage / shipment | 0 - 15,000 ft<br>0 - 40,000 ft   |

Note : Before and after Reliability test, LCM should be operated with normal function.

## Product Specification

## 7. International Standards

### 7-1. Safety

- a) UL 60065, Underwriters Laboratories Inc.  
Audio, Video and Similar Electronic Apparatus - Safety Requirements.
- b) CAN/CSA C22.2 No.60065:03, Canadian Standards Association.  
Audio, Video and Similar Electronic Apparatus - Safety Requirements.
- c) EN 60065, European Committee for Electrotechnical Standardization (CENELEC).  
Audio, Video and Similar Electronic Apparatus - Safety Requirements.
- d) IEC 60065, The International Electrotechnical Commission (IEC).  
Audio, Video and Similar Electronic Apparatus - Safety Requirements.  
(Including report of IEC60825-1:2001 clause 8 and clause 9)

#### Notes

##### 1. Laser (LED Backlight) Information

|   |
|---|
| Class 1M LED Product<br>IEC60825-1 : 2001<br>Embedded LED Power (Class1M) |
|---|

##### 2. Caution

- : LED inside.
- Class 1M laser (LEDs) radiation when open.
- Do not open while operating.

### 7-2. EMC

- a) ANSI C63.4 "American National Standard for Methods of Measurement of Radio-Noise Emissions from Low-Voltage Electrical and Electronic Equipment in the Range of 9 kHz to 40 GHz."  
American National Standards Institute (ANSI), 2003.
- b) CISPR 22 "Information technology equipment – Radio disturbance characteristics – Limit and methods of measurement." International Special Committee on Radio Interference (CISPR), 2005.
- c) CISPR 13 "Sound and television broadcast receivers and associated equipment – Radio disturbance characteristics – Limits and method of measurement." International Special Committee on Radio Interference (CISPR), 2006.

### 7-3. Environment

- a) RoHS, Directive 2002/95/EC of the European Parliament and of the council of 27 January 2003

## Product Specification

## 8. Packing

### 8-1. Information of LCM Label

#### a) Lot Mark

|   |   |   |   |   |   |   |   |   |   |   |   |   |
|---|---|---|---|---|---|---|---|---|---|---|---|---|
| A | B | C | D | E | F | G | H | I | J | K | L | M |
|---|---|---|---|---|---|---|---|---|---|---|---|---|

A,B,C : SIZE(INCH)

E : MONTH

D : YEAR

F ~ M : SERIAL NO.

#### Note

##### 1. YEAR

|      |      |      |      |      |      |      |      |      |      |      |
|------|------|------|------|------|------|------|------|------|------|------|
| Year | 2011 | 2012 | 2013 | 2014 | 2015 | 2016 | 2017 | 2018 | 2019 | 2020 |
| Mark | A    | B    | C    | D    | E    | F    | G    | H    | J    | K    |

##### 2. MONTH

|       |     |     |     |     |     |     |     |     |     |     |     |     |
|-------|-----|-----|-----|-----|-----|-----|-----|-----|-----|-----|-----|-----|
| Month | Jan | Feb | Mar | Apr | May | Jun | Jul | Aug | Sep | Oct | Nov | Dec |
| Mark  | 1   | 2   | 3   | 4   | 5   | 6   | 7   | 8   | 9   | A   | B   | C   |

#### b) Location of Lot Mark

Serial NO. is printed on the label. The label is attached to the backside of the LCD module.  
This is subject to change without prior notice.

### 8-2. Packing Form

a) Package quantity in one Pallet : 16 pcs

b) Pallet Size : 1300 mm(W) X 1140 mm(D) X 848.5 mm(H)

## Product Specification

## 9. Precautions

Please pay attention to the followings when you use this TFT LCD module.

### 9-1. Mounting Precautions

- (1) You must mount a module using specified mounting holes (Details refer to the drawings).
- (2) You should consider the mounting structure so that uneven force (ex. Twisted stress) is not applied to the module. And the case on which a module is mounted should have sufficient strength so that external force is not transmitted directly to the module.
- (3) Please attach the surface transparent protective plate to the surface in order to protect the polarizer. Transparent protective plate should have sufficient strength in order to resist external force.
- (4) You should adopt radiation structure to satisfy the temperature specification.
- (5) Acetic acid type and chlorine type materials for the cover case are not desirable because the former generates corrosive gas of attacking the polarizer at high temperature and the latter causes circuit break by electro-chemical reaction.
- (6) Do not touch, push or rub the exposed polarizers with glass, tweezers or anything harder than HB pencil lead. And please do not rub with dust clothes with chemical treatment. Do not touch the surface of polarizer for bare hand or greasy cloth.(Some cosmetics are detrimental to the polarizer.)
- (7) When the surface becomes dusty, please wipe gently with absorbent cotton or other soft materials like chamois soaks with petroleum benzene. Normal-hexane is recommended for cleaning the adhesives used to attach front / rear polarizers. Do not use acetone, toluene and alcohol because they cause chemical damage to the polarizer
- (8) Wipe off saliva or water drops as soon as possible. Their long time contact with polarizer causes deformations and color fading.
- (9) Do not open the case because inside circuits do not have sufficient strength.

### 9-2. Operating Precautions

- (1) Response time depends on the temperature.(In lower temperature, it becomes longer.)
- (2) Brightness depends on the temperature. (In lower temperature, it becomes lower.)  
And in lower temperature, response time(required time that brightness is stable after turned on) becomes longer
- (3) Be careful for condensation at sudden temperature change. Condensation makes damage to polarizer or electrical contacted parts. And after fading condensation, smear or spot will occur.
- (4) When fixed patterns are displayed for a long time, remnant image is likely to occur.
- (5) Module has high frequency circuits. Sufficient suppression to the electromagnetic interference shall be done by system manufacturers. Grounding and shielding methods may be important to minimize the interference.
- (6) Please do not give any mechanical and/or acoustical impact to LCM. Otherwise, LCM can't be operated its full characteristics perfectly.
- (7) A screw which is fastened up the steels should be a machine screw.  
(if not, it can cause conductive particles and deal LCM a fatal blow)
- (8) Please do not set LCD on its edge.
- (9) The conductive material and signal cables are kept away from LED driver inductor to prevent abnormal display, sound noise and temperature rising.

## Product Specification

### 9-3. Electrostatic Discharge Control

Since a module is composed of electronic circuits, it is not strong to electrostatic discharge. Make certain that treatment persons are connected to ground through wrist band etc. And don't touch interface pin directly.

### 9-4. Precautions for Strong Light Exposure

Strong light exposure causes degradation of polarizer and color filter.

### 9-5. Storage

When storing modules as spares for a long time, the following precautions are necessary.

- (1) Store them in a dark place. Do not expose the module to sunlight or fluorescent light. Keep the temperature between 5°C and 35°C at normal humidity.
- (2) The polarizer surface should not come in contact with any other object.  
It is recommended that they be stored in the container in which they were shipped.
- (3) Storage condition is guaranteed under packing conditions.
- (4) The phase transition of Liquid Crystal in the condition of the low or high storage temperature will be recovered when the LCD module returns to the normal condition

### 9-6. Handling Precautions for Protection Film

- (1) The protection film is attached to the bezel with a small masking tape.  
When the protection film is peeled off, static electricity is generated between the film and polarizer.  
This should be peeled off slowly and carefully by people who are electrically grounded and with well ion-blown equipment or in such a condition, etc.
- (2) When the module with protection film attached is stored for a long time, sometimes there remains a very small amount of glue still on the bezel after the protection film is peeled off.
- (3) You can remove the glue easily. When the glue remains on the bezel surface or its vestige is recognized, please wipe them off with absorbent cotton waste or other soft material like chamois soaked with normal-hexane.

### 9-7. Operating condition guide

- (1) The LCD product should be operated under normal conditions. Normal condition is defined as below;
  - Temperature : 5 ~ 40 °C, normal humidity.
  - Display pattern : continually changing pattern (Not stationary)
- (2) If the product will be used in extreme conditions such as high temperature, display patterns or operation time etc.,  
It is strongly recommended to contact LGD for Qualification engineering advice. Otherwise, its reliability and function may not be guaranteed. Extreme conditions are commonly found at Airports, Transit Stations, Banks, Stock market, and Controlling systems. The LCD product should be applied by global standard environment. (refer ETSI EN 300, IEC 60721)



LC470EUD

## Product Specification

## # APPENDIX-I

## ■ Pallet Ass'y

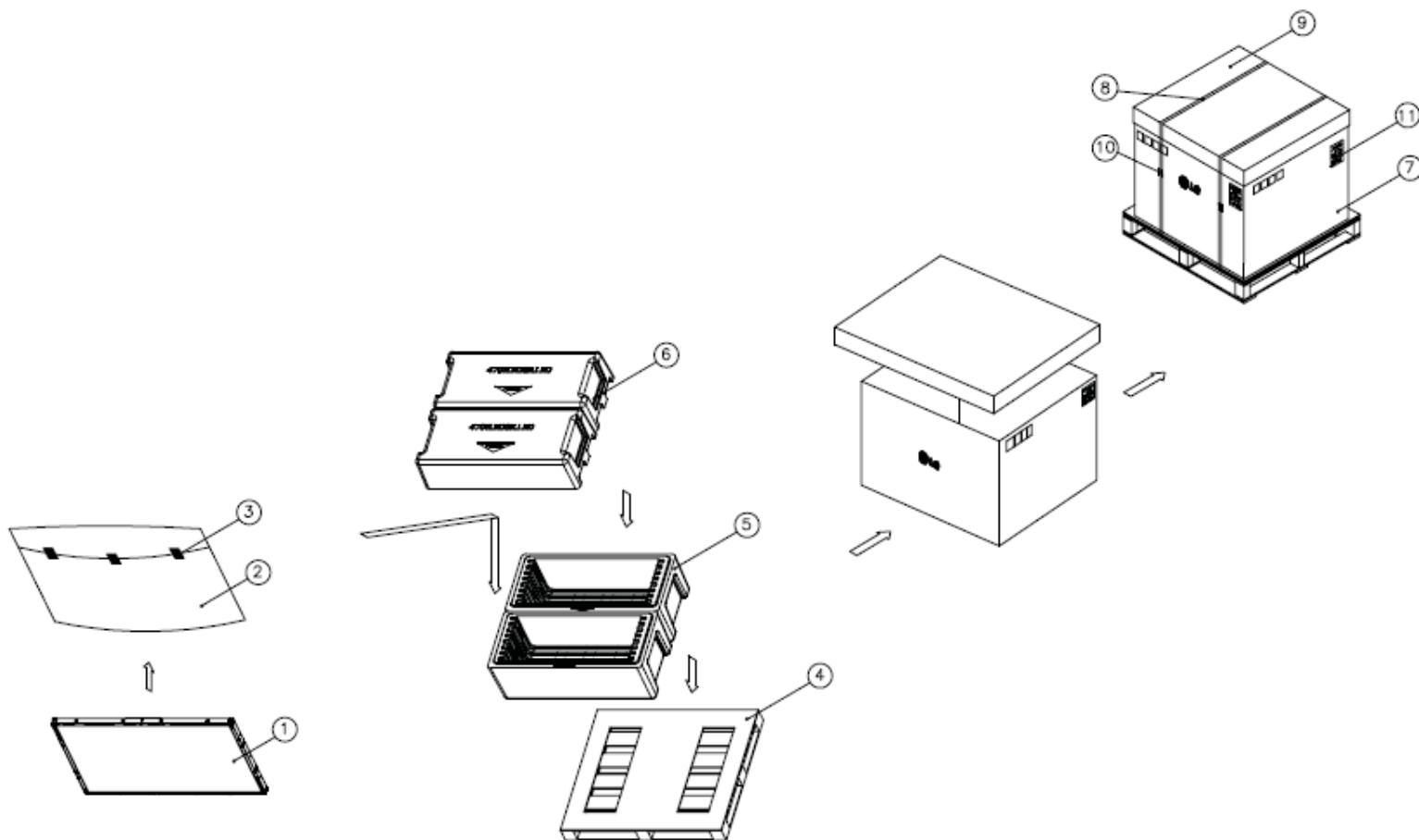

| NO. | DESCRIPTION    | MATERIAL                  |
|-----|----------------|---------------------------|
| 1   | LCD Module     | 47" LCD                   |
| 2   | BAG            | 47INCH                    |
| 3   | TAPE           | MASKING 20MMX50M          |
| 4   | PALLET         | Plywood 1300X1140X125.5mm |
| 5   | PACKING,BOTTOM | EPS                       |
| 6   | PACKING, TOP   | EPS                       |
| 7   | ANGLE,PACKING  | PAPER                     |
| 8   | BAND           | PP                        |
| 9   | ANGLE,COVER    | PAPER                     |
| 10  | BAND           | STEEL OR PP               |
| 11  | LABEL          | YUPO 80G 100X70           |

LC470EUD

## Product Specification

## # APPENDIX- II-1

## ■ LCM Label

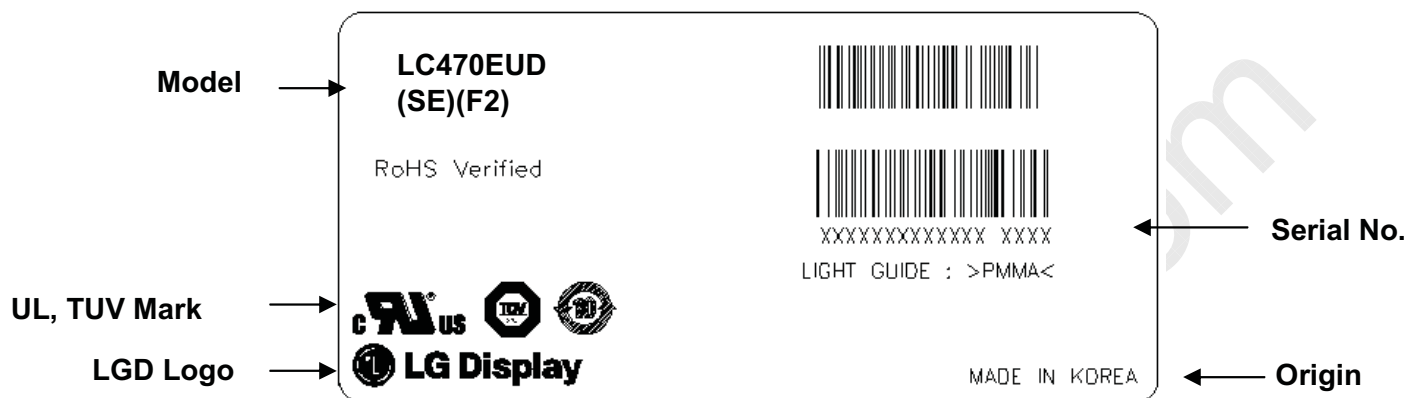

LC470EUD

## Product Specification

## # APPENDIX- II-2

## ■ Pallet Label



## Product Specification

## # APPENDIX- III-1

■ Required signal assignment for Flat Link (Thine : THC63LVD103) Transmitter(Pin7= "L" or "NC")

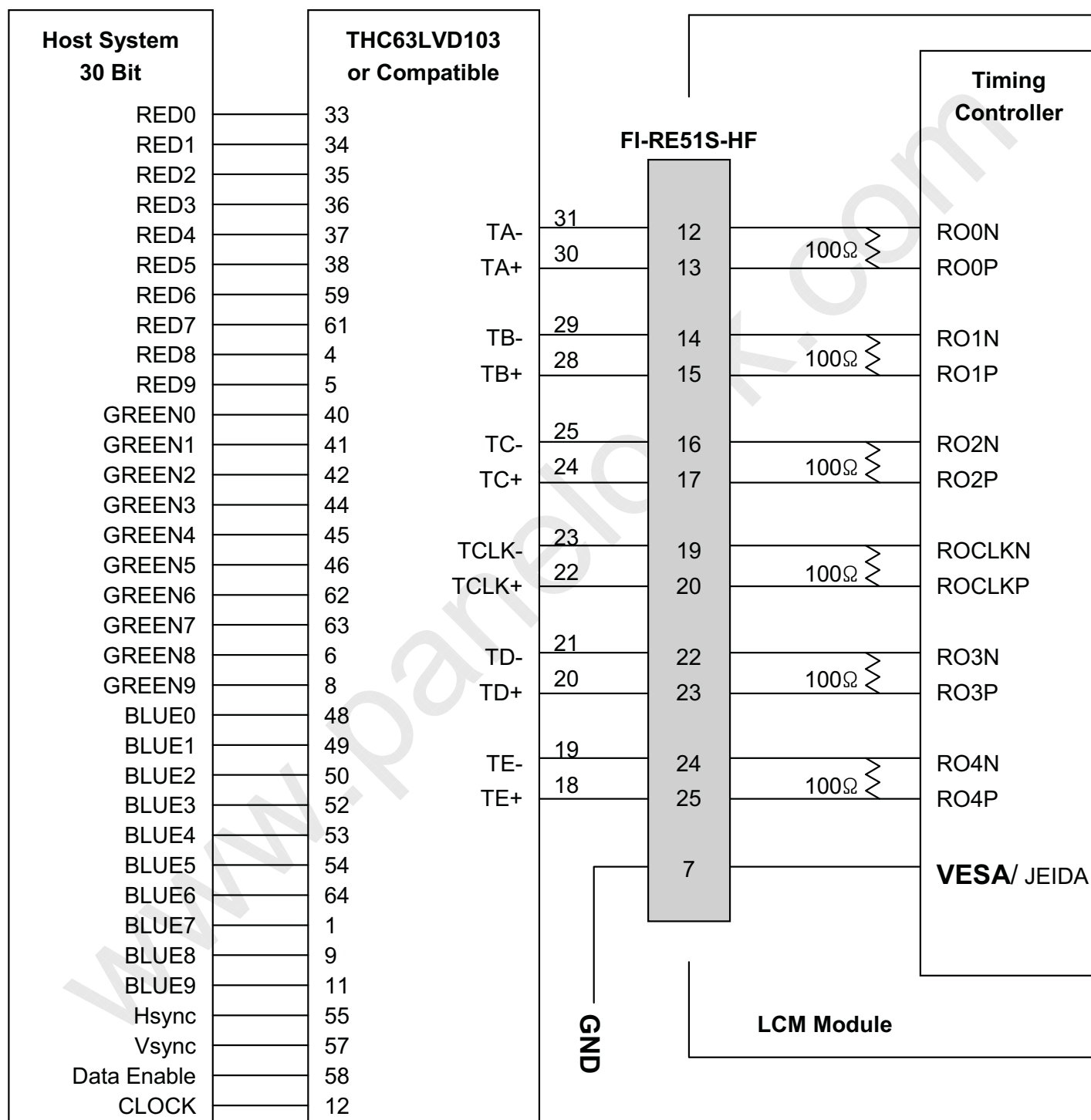

- Note: 1. The LCD module uses a 100 Ohm[Ω] resistor between positive and negative lines of each receiver input.
2. Refer to LVDS Transmitter Data Sheet for detail descriptions. (THC63LVD103 or Compatible)
3. '9' means MSB and '0' means LSB at R,G,B pixel data.

## Product Specification

## # APPENDIX- III-2

■ Required signal assignment for Flat Link (Thine : THC63LVD103) Transmitter(Pin7= "H" )

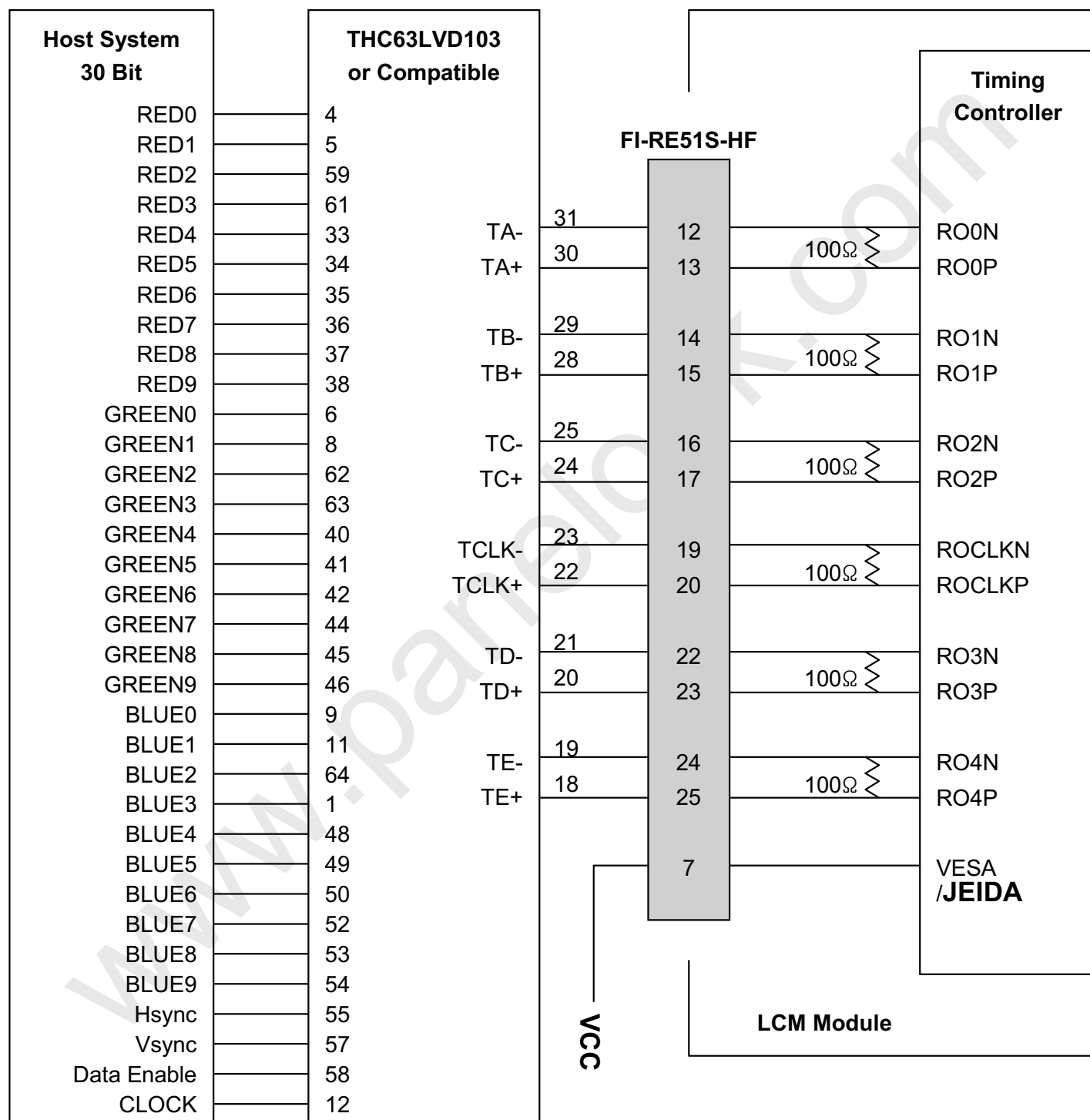

Note :1. The LCD module uses a 100 Ohm[Ω] resistor between positive and negative lines of each receiver input.

2. Refer to LVDS Transmitter Data Sheet for detail descriptions. (THC63LVD103 or Compatible)

3. '9' means MSB and '0' means LSB at R,G,B pixel data.

## Product Specification

## # APPENDIX- IV-1

## ■ LVDS Data-Mapping Information (10 Bit )

## 1) LVDS Select : "H" Data-Mapping (JEIDA format)

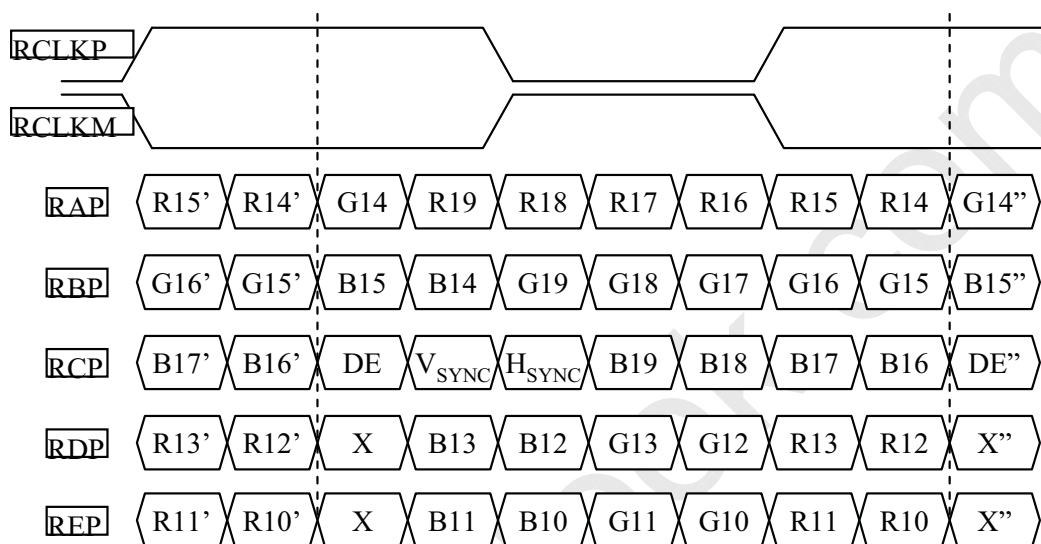

## 2) LVDS Select : "L" Data-Mapping (VESA format)

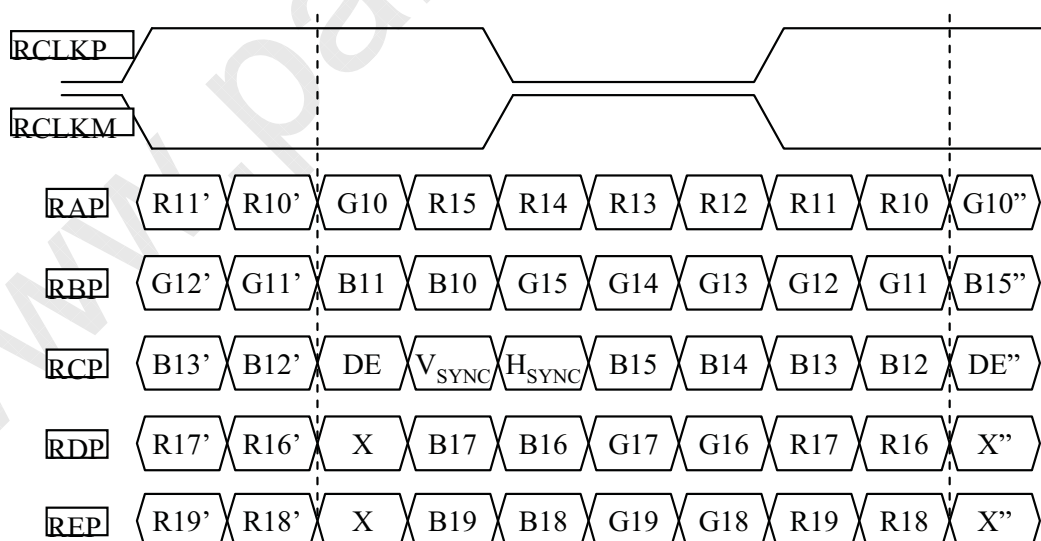

## Product Specification

## # APPENDIX- IV-2

## ■ LVDS Data-Mapping Information (8 Bit )

## 1) LVDS Select : "H" Data-Mapping (JEIDA format)

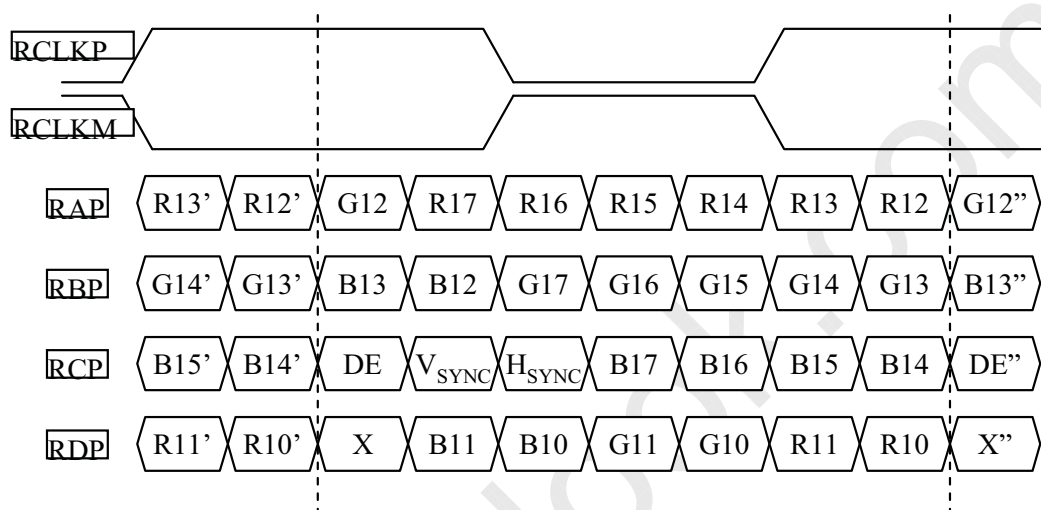

## 2) LVDS Select : "L" Data-Mapping (VESA format)

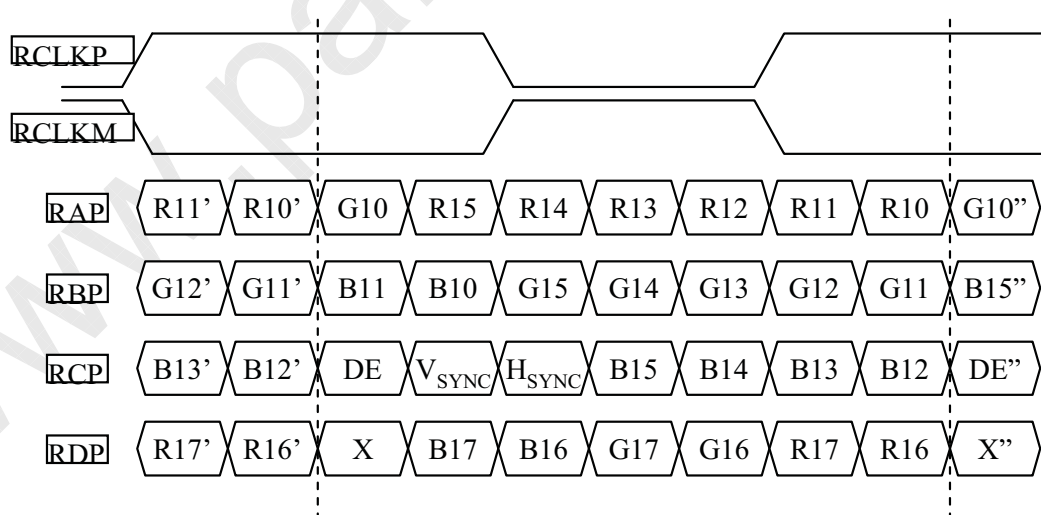

## Product Specification

## # APPENDIX- V-1

## ■ Option Pin Circuit Block Diagram

## 1) Circuit Block Diagram of LVDS Selection pin

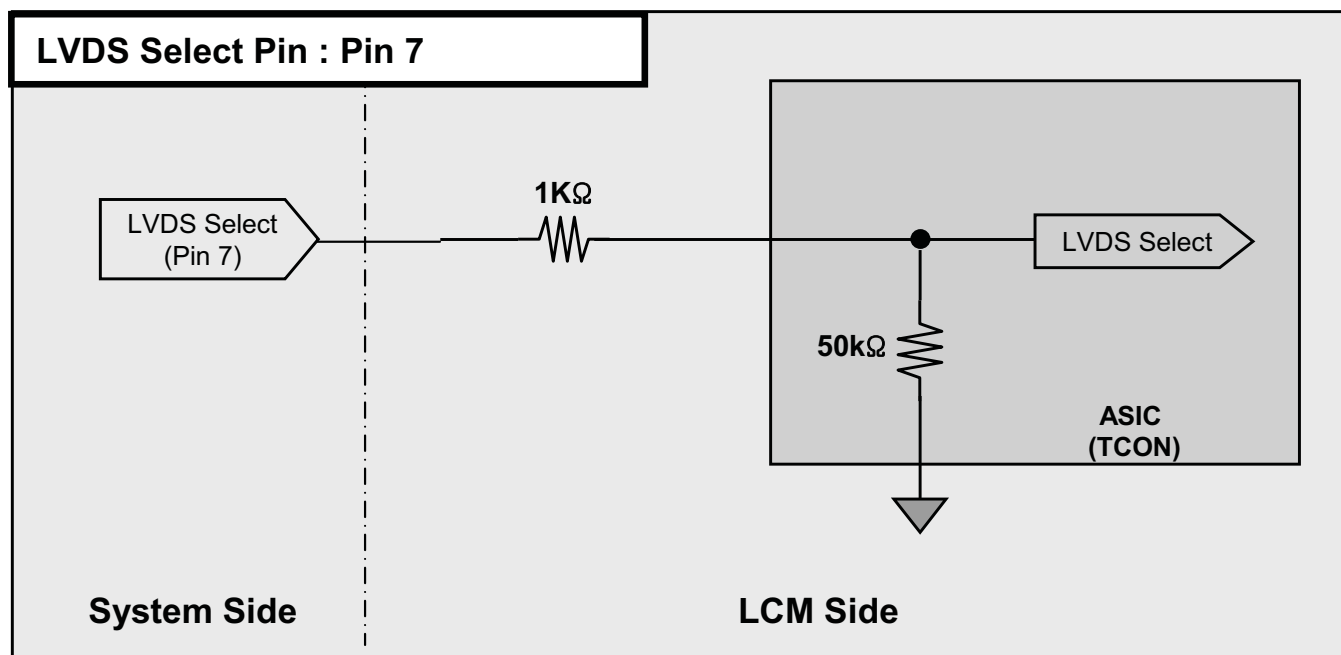

## 2) Circuit Block Diagram of L-DIM Enable Selection pin

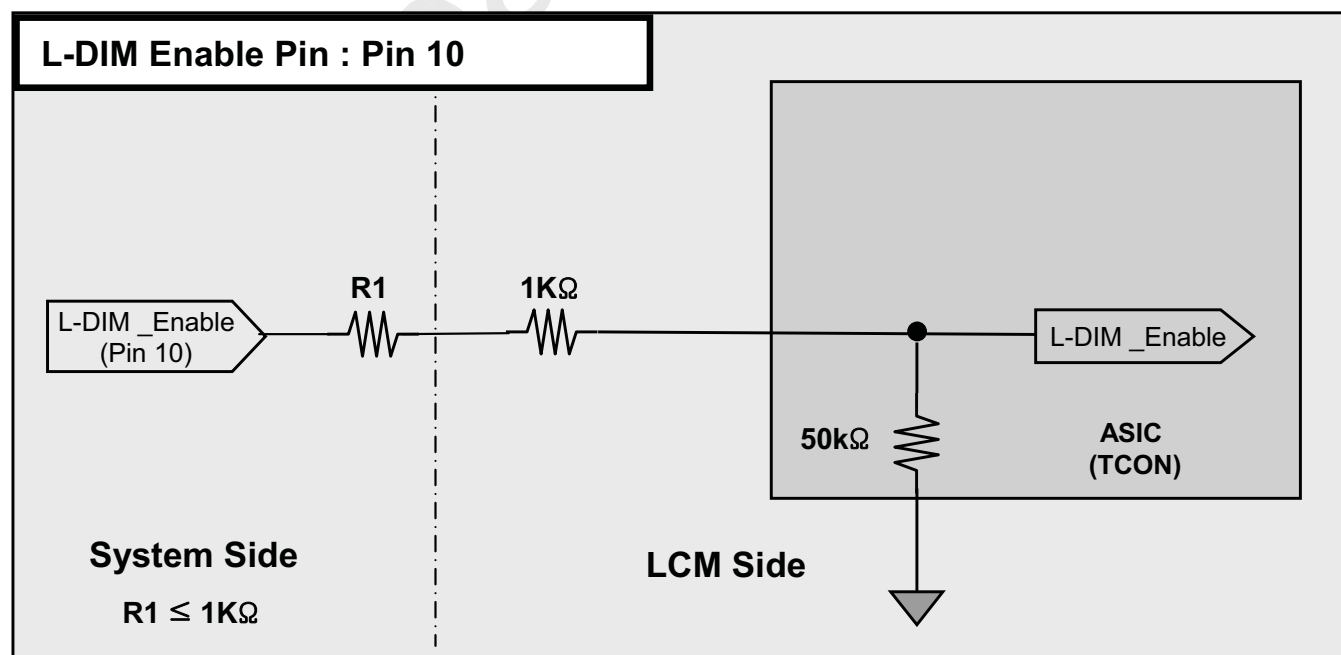



## Product Specification

## # APPENDIX- V-2

## ■ Option Pin Circuit Block Diagram

## 3) Circuit Block Diagram of Bit Selection pin

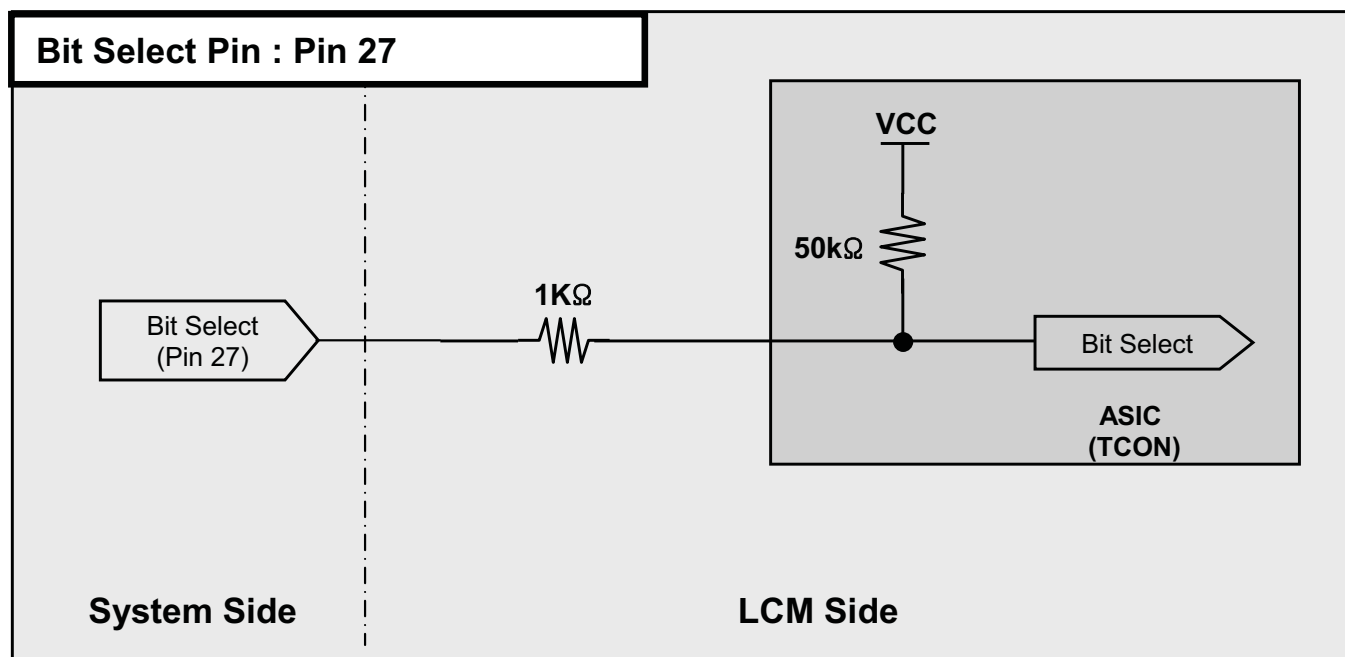

## 4) Circuit Block Diagram of PCID\_EN Selection pin

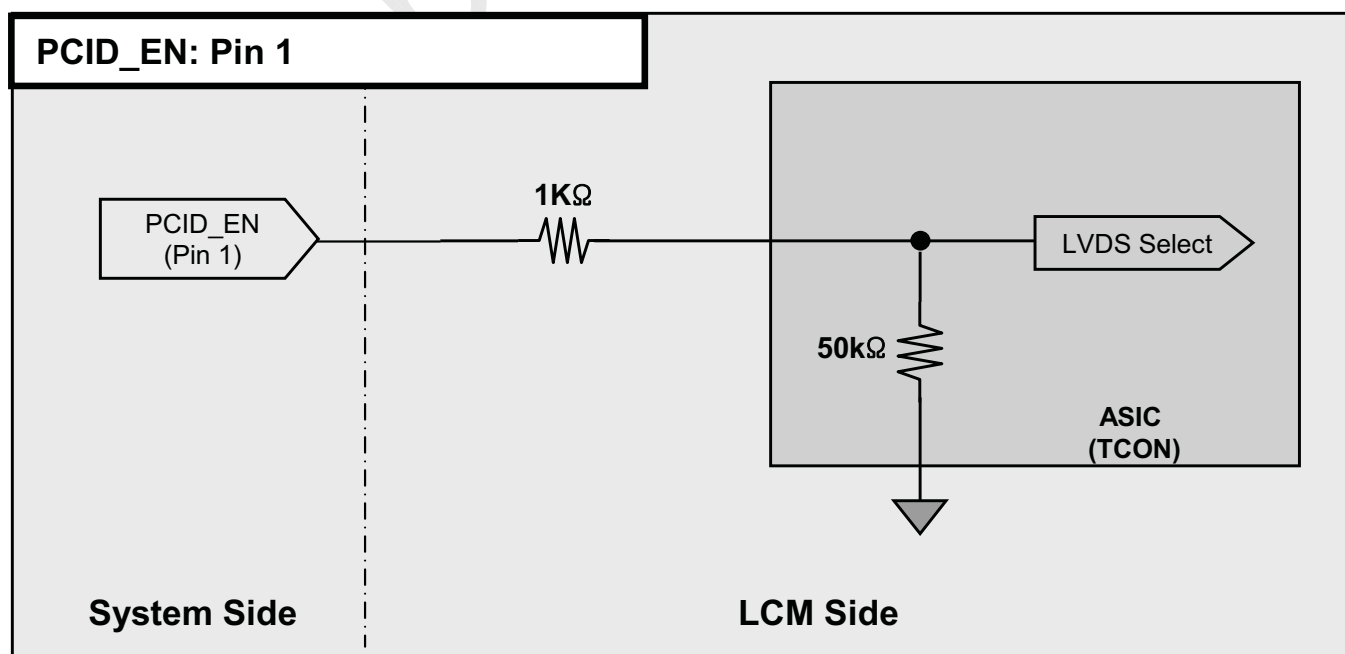

Product Specification

# APPENDIX- VI

■ EXT<sub>VB</sub>R-B & Local Dimming Design Guide

- 1) When L-Dim Enable is "L", Vertical Sync Signal = System Dimming with 100Hz or 120Hz frequency.
- 2) Local Dimming signals are synchronized with V-Sync Freq. of System in T-Con Board.
- 3) EXT<sub>VB</sub>R-B Specification ( VCC = 3.3V ) @ Local Dimming
  - a) High Voltage Range : 2.5 V ~ 3.6 V
  - b) Low Voltage Range : 0.0 V ~ 0.8 V

(4pin)  
 #1 : Vertical Sync signal  
 #2 : GND  
 #3 : Local Dimming Serial Data  
 #4 : Local Dim Serial Clock

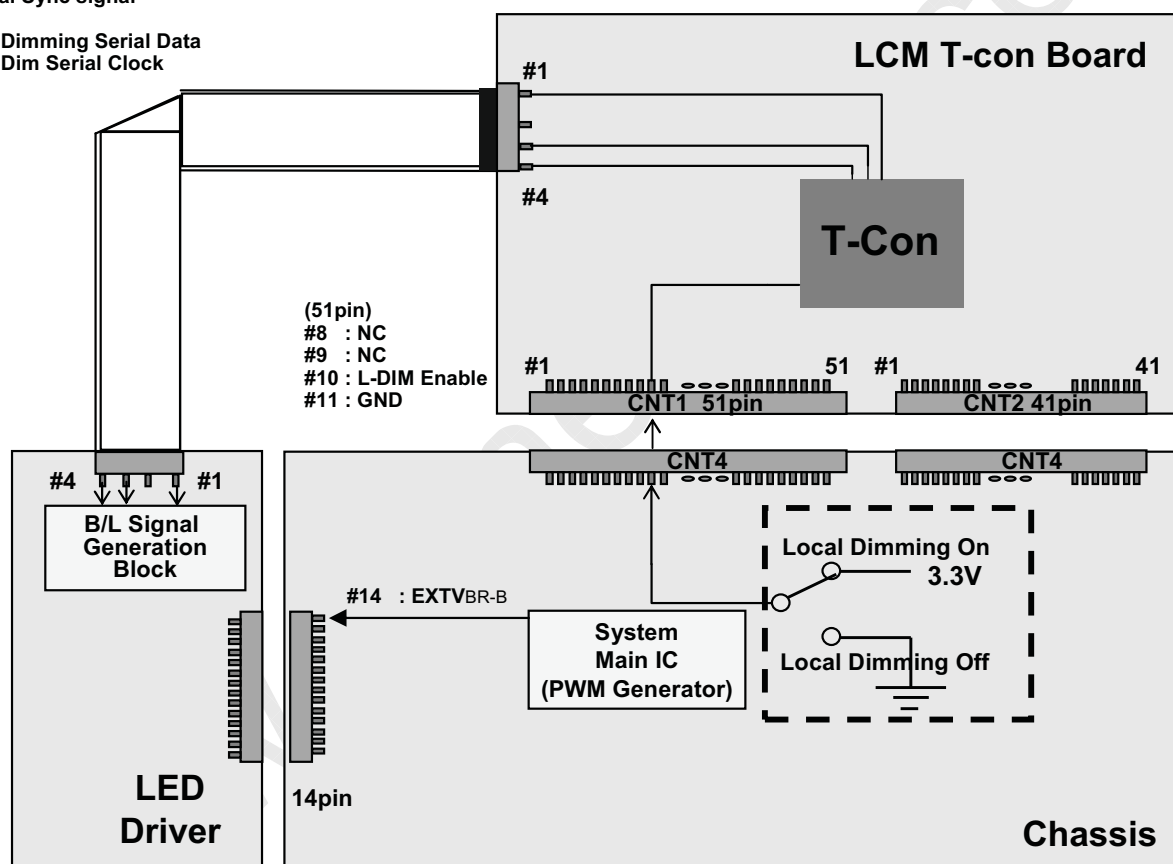

<With Driver Model>

|                                 |                                   |
|---------------------------------|-----------------------------------|
| EXT <sub>VB</sub> R-B Frequency | 100 Hz for PAL<br>120 Hz for NTSC |
| Rising Time                     | MAX 10.0 μs                       |
| Falling Time                    | MAX 10.0 μs                       |

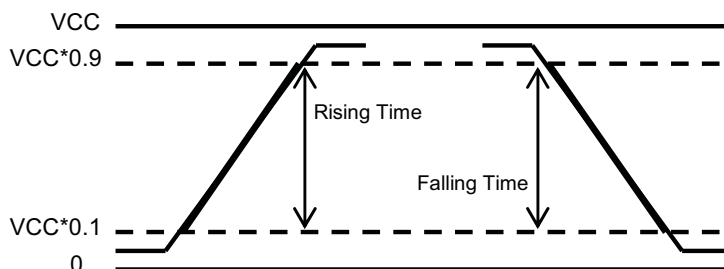

Product Specification

# APPENDIX- VII-1

## Gray to Gray Response Time Uniformity

This is only the reference data of G to G and uniformity for LC470EUD-SEF2 model.

1. G to G Response Time :

Response time is defined as Figure3 and shall be measured by switching the input signal for "Gray (N) " and "Gray(M)".(32Gray Step at 8bit)

2. G to G Uniformity

The variation of G to G Uniformity ,  $\delta_{G \text{ to } G}$  is defined as :

$$G \text{ to } G \text{ Uniformity} = \frac{\text{Maximum}(G \text{ to } G) - \text{Typical}(G \text{ to } G)}{\text{Typical}(G \text{ to } G)} \leq 1$$

\*Maximum (G to G) means maximum value of measured time (N, M = 0 (Black) ~ 1023(White), 128 gray step).

|          |              |                |                |     |                |                |
|----------|--------------|----------------|----------------|-----|----------------|----------------|
|          | 0Gray        | 127ray         | 255Gray        | ... | 895Gray        | 1023Gray       |
| 0Gray    |              | TrR:0G→127G    | TrR:0G→255G    | ... | TrR:0G→895G    | TrR:0G→1023G   |
| 127Gray  | TrD:127G→0G  |                | TrR:127G→255G  | ... | TrR:127G→895G  | TrR:127G→1023G |
| 255Gray  | TrD:255G→0G  | TrD:255G→127G  |                | ... | TrR:255G→895G  | TrR:255G→1023G |
| ...      | ...          | ...            | ...            | ... | ...            | ...            |
| 895Gray  | TrD:895G→0G  | TrD:895G→127G  | TrD:895G→255G  | ... |                | TrR:895G→1023G |
| 1023Gray | TrD:1023G→0G | TrD:1023G→127G | TrD:1023G→255G | ... | TrD:1023G→895G |                |

3. Sampling Size : 2 pcs

4. Measurement Method : Follow the same rule as optical characteristics measurement.

5. Current Status

Below table is actual data of production on **XXX.XX. 2011 ( LGD RV Event Sample)**

|     | G to G Response Time [ms] |      | Uniformity |
|-----|---------------------------|------|------------|
|     | Min.                      | Max. |            |
| # 1 |                           |      |            |
| # 2 |                           |      |            |

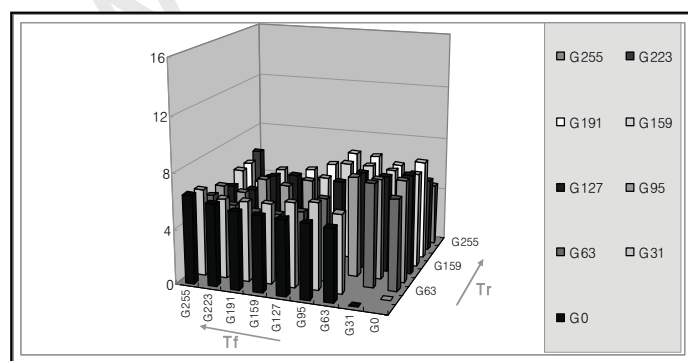

< # 1 >

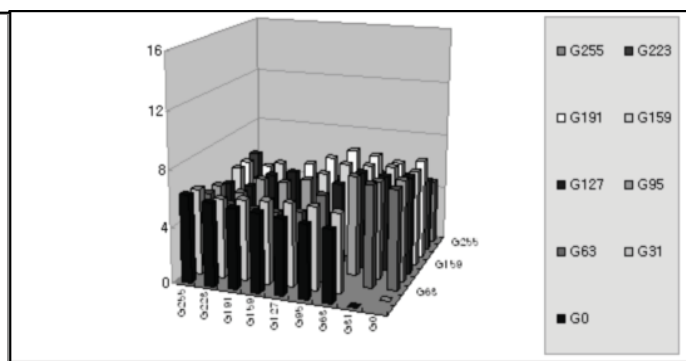

< # 2 >

Product Specification

## # APPENDIX- VII-2

### ■ MPRT Response Time Uniformity ( $\delta_{MPRT}$ )

This is only the reference data of MPRT and uniformity for LC470EUD-SEF2 model.

1. MPRT Response Time :  
Response time is defined as Figure3

2. MPRT Uniformity  
The variation of MPRT Uniformity ,  $\delta_{MPRT}$  is defined as :

$$MPRT \text{ Uniformity} = \frac{\text{Maximum (MPRT)} - \text{Typical (MPRT)}}{\text{Typical (MPRT)}} \leq 1$$

3. Sampling Size : 2 pcs

4. Measurement Method : Follow the same rule as optical characteristics measurement.

5. Current Status

Below table is actual data of production on **XXX. XX. 2011 ( LGD RV Event Sample)**

| Sample | MPRT Response Time [ms] |      | Uniformity |
|--------|-------------------------|------|------------|
|        | Min.                    | Max. |            |
| # 1    |                         |      |            |
| # 2    |                         |      |            |

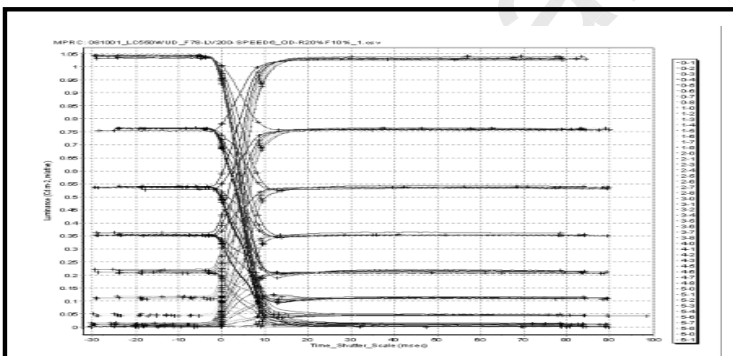

| BET        | (msec)   | Ini: 0   | Ini: 1   | Ini: 2   | Ini: 3   | Ini: 4   | Ini: 5   | Ini: 6   | Ini: 7   | Ini: 8 |
|------------|----------|----------|----------|----------|----------|----------|----------|----------|----------|--------|
| Fin: 0     | -        | removed  | 9.347136 | 9.454481 | 9.667864 | 9.734955 | 9.527641 | 9.358508 | 9.517707 |        |
| Fin: 1     | removed  | -        | 8.075697 | 8.582398 | 9.384924 | 9.605858 | 9.424253 | 9.365118 | 9.513265 |        |
| Fin: 2     | 8.344561 | 8.217446 | -        | 8.624713 | 8.762079 | 8.834579 | 8.762864 | 8.769723 | 8.993056 |        |
| Fin: 3     | 8.262307 | 8.299946 | 8.269214 | -        | 8.786842 | 9.002887 | 8.44375  | 8.052575 | 8.018448 |        |
| Fin: 4     | 9.417341 | 9.086708 | 8.513305 | 9.189118 | -        | 9.0812   | 8.700772 | 8.284472 | 7.919536 |        |
| Fin: 5     | 9.647793 | 9.542058 | 9.355445 | 9.162106 | 9.984277 | -        | 8.633597 | 8.429259 | 8.456269 |        |
| Fin: 6     | 9.369971 | 9.371933 | 9.229201 | 9.104013 | 8.991796 | 8.922821 | -        | 8.33809  | 8.104774 |        |
| Fin: 7     | 9.223922 | 9.160715 | 9.025495 | 8.865578 | 8.697822 | 8.595682 | 8.636437 | -        | 8.386642 |        |
| Fin: 8     | 9.355655 | 9.251257 | 9.049527 | 8.837964 | 8.661122 | 8.460656 | 8.366696 | 8.207234 | -        |        |
| average    |          | 8.880329 |          |          |          |          |          |          |          |        |
| standard d |          | 0.484756 |          |          |          |          |          |          |          |        |
| maximum    |          | 9.734955 |          |          |          |          |          |          |          |        |
| minimum    |          | 7.919536 |          |          |          |          |          |          |          |        |

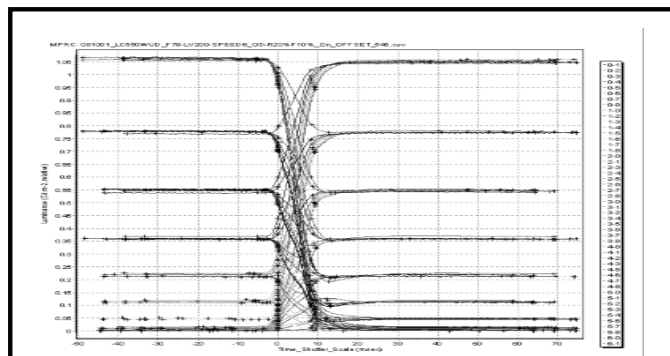

| BET        | (msec)   | Ini: 0   | Ini: 1   | Ini: 2   | Ini: 3   | Ini: 4   | Ini: 5   | Ini: 6   | Ini: 7   | Ini: 8 |
|------------|----------|----------|----------|----------|----------|----------|----------|----------|----------|--------|
| Fin: 0     | -        | removed  | 9.275195 | 9.524317 | 9.679588 | 9.707105 | 9.494056 | 9.379901 | 9.456676 |        |
| Fin: 1     | removed  | -        | 8.443896 | 8.661854 | 9.339427 | 9.575764 | 9.450483 | 9.303195 | 9.43465  |        |
| Fin: 2     | 8.214059 | 8.164917 | -        | 8.674104 | 8.775159 | 8.813825 | 8.784625 | 8.717827 | 8.906641 |        |
| Fin: 3     | 8.246839 | 8.216053 | 8.101007 | -        | 8.897637 | 9.085222 | 8.384497 | 8.059585 | 8.034227 |        |
| Fin: 4     | 9.433491 | 9.023004 | 8.480595 | 9.042484 | -        | 8.996973 | 8.771072 | 8.292302 | 7.833995 |        |
| Fin: 5     | 9.542422 | 9.470281 | 9.295105 | 9.087839 | 8.853569 | -        | 8.738979 | 8.380587 | 8.396386 |        |
| Fin: 6     | 9.298591 | 9.325589 | 9.228585 | 9.044294 | 8.889273 | 8.78052  | -        | 8.53577  | 8.245636 |        |
| Fin: 7     | 9.158549 | 9.080733 | 8.960548 | 8.831113 | 8.665631 | 8.536265 | 8.461913 | -        | 8.442273 |        |
| Fin: 8     | 9.275476 | 9.174591 | 8.943088 | 8.769971 | 8.562974 | 8.337292 | 8.192263 | 8.079837 | -        |        |
| average    |          | 8.846588 |          |          |          |          |          |          |          |        |
| standard d |          | 0.476354 |          |          |          |          |          |          |          |        |
| maximum    |          | 9.707105 |          |          |          |          |          |          |          |        |
| minimum    |          | 7.833995 |          |          |          |          |          |          |          |        |

Product Specification

# APPENDIX- VIII

■ Standard specification of Eyeglasses

This is recommended data of Eyeglasses for LC470EUD-SEF2 model. (details refer to table)

For each item, depending on the eyeglass manufacturer tolerances may occur, this tolerance can affect 3D performance. (3D Crosstalk, 3D luminance, 3D viewing angle)

<Table. Standard specification of Eyeglasses>

| Design item of Eyeglasses |                                   | Left  | Right | Remark           |
|---------------------------|-----------------------------------|-------|-------|------------------|
| Optical axis              | a) Slow axis of retarder          | -45°  | 45°   | Refer to drawing |
|                           | b) Transmission axis of polarizer | 0°    | 0°    |                  |
| Retardation value         | Retarder                          | 125nm |       | @550nm           |

※Recommended polarizer  
Polarization efficiency: more than 99.90%

