



LC470WU5

Product Specification

SPECIFICATION FOR APPROVAL

() Preliminary Specification

(●) Final Specification

Title	47.0" WUXGA TFT LCD
-------	---------------------

BUYER	
MODEL	

SUPPLIER	LG Display Co., Ltd.
*MODEL	LC470WU5
SUFFIX	SLA1 (RoHS Verified)

*When you obtain standard approval,
please use the above model name without suffix

APPROVED BY	SIGNATURE	DATE
/		
/		
/		

Please return 1 copy for your confirmation with your signature and comments.

APPROVED BY	SIGNATURE	DATE
J.H. Yoon /Senior Manager		
REVIEWED BY		
P.Y. Kim / Manager		
PREPARED BY		
Y. N. Lee / Engineer		

TV Product Development Dept.
LG Display Co., Ltd

Product Specification

CONTENTS

Number	ITEM	Page
	COVER	1
	CONTENTS	2
	RECORD OF REVISIONS	3
1	GENERAL DESCRIPTION	4
2	ABSOLUTE MAXIMUM RATINGS	5
3	ELECTRICAL SPECIFICATIONS	6
3-1	ELECTRICAL CHARACTERISTICS	6
3-2	INTERFACE CONNECTIONS	10
3-3	SIGNAL TIMING SPECIFICATIONS	12
3-4	SIGNAL TIMING WAVEFORMS	14
3-5	COLOR DATA REFERENCE	15
3-6	POWER SEQUENCE	16
4	OPTICAL SPECIFICATIONS	17
5	MECHANICAL CHARACTERISTICS	21
6	RELIABILITY	24
7	INTERNATIONAL STANDARDS	25
7-1	SAFETY	25
7-2	EMC	25
8	PACKING	26
8-1	DESIGNATION OF LOT MARK	26
8-2	PACKING FORM	26
9	PRECAUTIONS	27
9-1	MOUNTING PRECAUTIONS	27
9-2	OPERATING PRECAUTIONS	27
9-3	ELECTROSTATIC DISCHARGE CONTROL	28
9-4	PRECAUTIONS FOR STRONG LIGHT EXPOSURE	28
9-5	STORAGE	28
9-6	HANDLING PRECAUTIONS FOR PROTECTION FILM	28
APPENDIX I	LVDS Mapping Reference Table	

LC470WU5

Product Specification

1. General Description

The LC470WU5 is a Color Active Matrix Liquid Crystal Display with an integral Cold Cathode Fluorescent Lamp(CCFL) backlight system. The matrix employs a-Si Thin Film Transistor as the active element. It is a transmissive display type which is operating in the normally black mode. It has a 46.96 inch diagonally measured active display area with WUXGA resolution (1080 vertical by 1920 horizontal pixel array). Each pixel is divided into Red, Green and Blue sub-pixels or dots which are arrayed in vertical stripes. Gray scale or the luminance of the sub-pixel color is determined with a 10-bit gray scale signal for each dot. Therefore, it can present a palette of more than 1.07 Billion (FRC) colors.

It has been designed to apply the 10-bit 2-port LVDS interface.

It is intended to support LCD TV, PCTV where high brightness, super wide viewing angle, high color gamut, high color depth and fast response time are important.

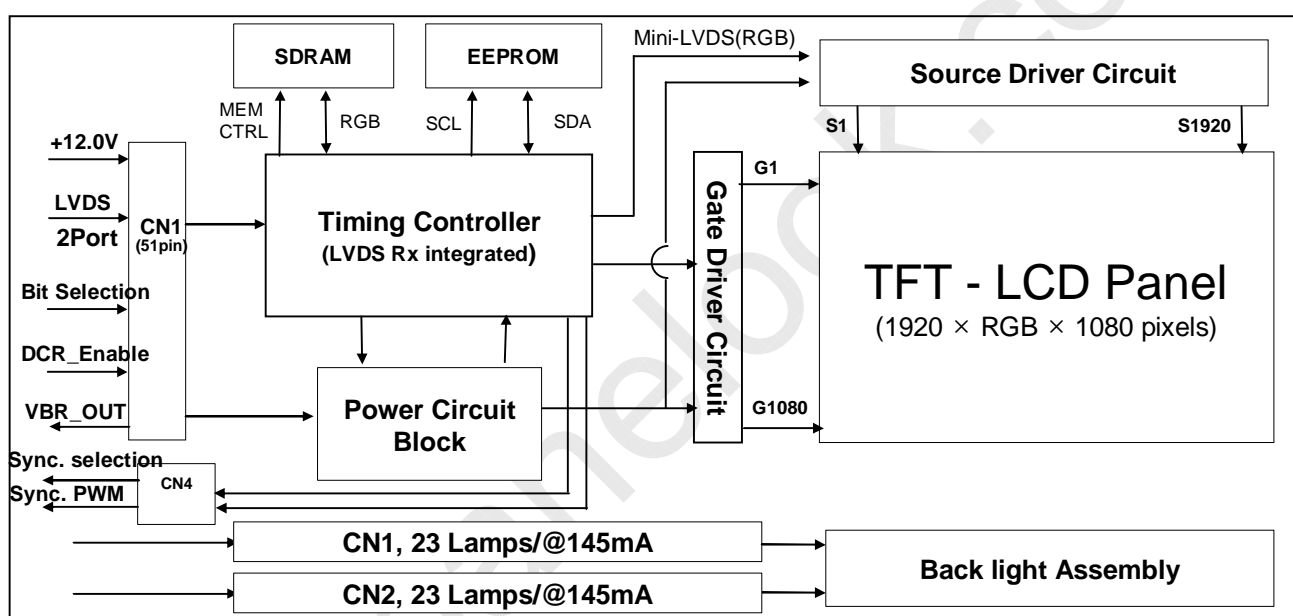

General Features

Active Screen Size	46.96 inch (1192.87mm) diagonal
Outline Dimension	1096.0(H) x 640.0 (V) x 51 mm(D) (Typ.)
Pixel Pitch	0.5415 mm x 0.5415 mm
Pixel Format	1920 horiz. by 1080 vert. Pixels, RGB stripe arrangement
Color Depth	8-bit-FRC, 1.07 Billion colors
Luminance, White	500 cd/m ² (Center 1point ,Typ.)
Viewing Angle (CR>10)	Viewing angle free (R/L 178 (Min.), U/D 178 (Min.))
Power Consumption	Total 230.2 W (Typ.) (Logic=7.20 W, Backlight=223W @with inverter)
Weight	14.5 Kg (Typ.)
Display Mode	Transmissive mode, Normally black
Surface Treatment	Hard coating(3H), Anti-glare treatment of the front polarizer

LC470WU5

Product Specification

2. Absolute Maximum Ratings

The following items are maximum values which, if exceeded, may cause faulty operation or damage to the LCD module.

Table 1. ABSOLUTE MAXIMUM RATINGS

Parameter		Symbol	Value		Unit	Remark
			Min	Max		
Power Input Voltage	LCM	V_{LCD}	8.0	+14.0	V_{DC}	at $25 \pm 2^\circ\text{C}$
Inverter output	Voltage	V_{BL}		2500	V_{rms}	
	Current	I_{BL}	120	180	ImA rms	
Operating Temperature		T_{OP}	0	+50	$^\circ\text{C}$	Note 1
Storage Temperature		T_{ST}	-20	+60	$^\circ\text{C}$	
Operating Ambient Humidity		H_{OP}	10	90	%RH	
Storage Humidity		H_{ST}	10	90	%RH	

Note : 1. Temperature and relative humidity range are shown in the figure below.

Wet bulb temperature should be 39°C Max. and no condensation of water.

2. Gravity mura can be guaranteed under 40°C condition.

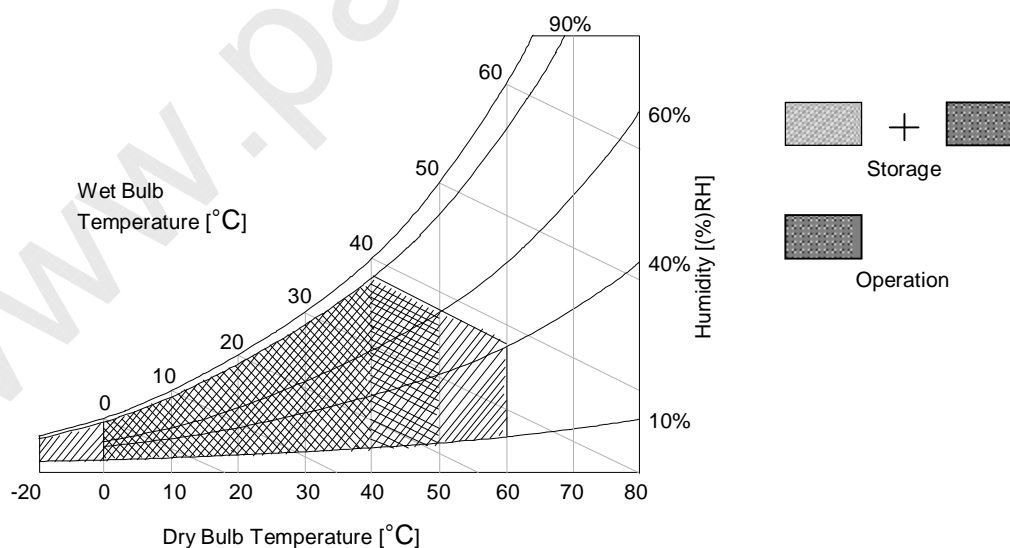

Product Specification

3. Electrical Specifications**3-1. Electrical Characteristics**

It requires two power inputs. One is employed to power for the LCD circuit.
The other is used for the CCFL backlight and inverter circuit.

Table 2. ELECTRICAL CHARACTERISTICS

Parameter	Symbol	Value			Unit	Note
		Min	Typ	Max		
Circuit :						
Power Input Voltage	V_{LCD}	11.4	12.0	12.6	V_{DC}	
Power Input Current	I_{LCD}	-	600	780	mA	1
		-	870	1130	mA	2
Power Consumption	P_{LCD}	-	7.20	9.36	Watt	1
Rush current	I_{RUSH}	-	-	5	A	3

- Note : 1. The specified current and power consumption are under the $V_{LCD}=12.0V$, $25 \pm 2^{\circ}C$, $f_V=60Hz$ condition whereas mosaic pattern(8 x 6) is displayed and f_V is the frame frequency.
2. The current is specified at the maximum current pattern.
3. The duration of rush current is about 2ms and rising time of power input is 1ms (min.).

White : 1023 Gray
Black : 0 Gray

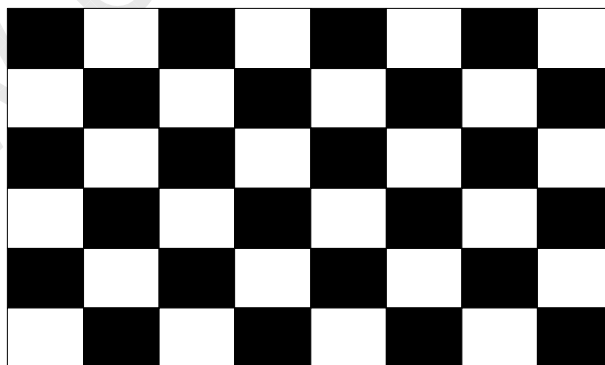

Mosaic Pattern(8 x 6)

LC470WU5

Product Specification

Table 3. ELECTRICAL CHARACTERISTICS for IPB& Lamp (Continue)

Parameter	Symbol	Values			Unit	Notes
		Min	Typ	Max		
Backlight Assembly :						
Operating Voltage (one side, f _{BL} =44KHz, I _{BL} = 145mA _{RMS})	V _{BL}	-	1400	-	V _{RMS}	1, 2
Operating Current (one side)	I _{BL}	-	145	-	mA _{RMS}	1
Established Starting Voltage (one side)	V _S	0℃	-	1800	V _{RMS}	1, 3
		25℃	-	1550		
Operating Frequency	f _{BL}	42	44	46	kHz	4
Striking Time	S TIME	-	-	1.5	sec	3
Balance Cap.	C _b	20.9	22	23.1	pF	13
Power Consumption	P _{BL}		223		Watt	6
Burst Dimming Duty	PWM duty	20		100	%	9
Burst Dimming Frequency	1/T	150	-	180	Hz	9

Parameter	Symbol	Values			Unit	Notes
		Min	Typ	Max		
Lamp : (APPENDIX-II)						
Lamp Voltage (one side)	V _{LAMP}	725	800	890	V _{RMS}	1, 2
Lamp Current (one side)	I _{LAMP}	3	6	8	mA _{RMS}	1
Discharge Stabilization Time	T _S	-	-	3	Min	1, 5
Lamp Frequency	f _{LAMP}	40	48	80	KHz	
Lamp Temperature	T _{LAMP}			130	℃	
Established Starting Voltage (one side)	0℃	V _S		1500	V _{RMS}	1, 3
	25℃	V _S		1250		
Life Time		50,000			Hrs	7

Note : The design of the inverter must have specifications for the lamp in LCD Assembly.

The electrical characteristics of inverter are based on High-High Driving type.

The performance of the lamps in LCM, for example life time or brightness, is extremely influenced by the characteristics of the DC-AC inverter. So, all the parameters of an inverter should be carefully designed so as not to produce too much leakage current from high-voltage output of the inverter.

When you design or order the inverter, please make sure unwanted lighting caused by the mismatch of the lamp and the inverter (no lighting, flicker, etc) has never been occurred. When you confirm it, the LCD- Assembly should be operated in the same condition as installed in your instrument.

※ Do not attach a conductive tape to lamp connecting wire.

If you attach conductive tape to the lamp wire, not only luminance level can be lower than typical one but also inverter operate abnormally on account of leakage current which is generated between lamp wire and conductive tape.

- Specified values are defined for a Backlight Assembly.(I_{BL} : 23 lamp, 6.3mA/Lamp)
- Operating voltage is measured at 25 ± 2℃(after 2hr.aging). The variance range for operating voltage is ± 10%.
- The established starting voltage [V_S] should be applied to the lamps for more than Striking time (S TIME) for start-up. Inverter open voltage must be more than established starting voltage. Otherwise, the lamps may not be turned on. The used lamp current is typical value.

Product Specification

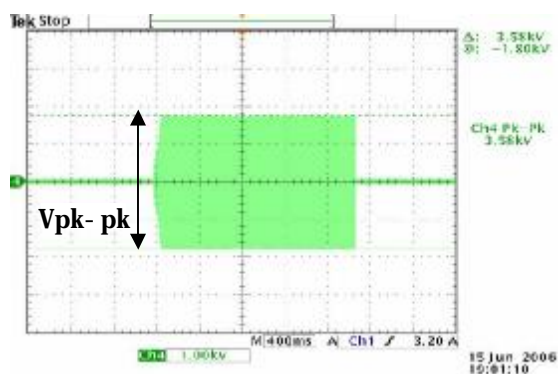

$$V_s = (V_{pk-pk}) / [2 \cdot \sqrt{2}]$$

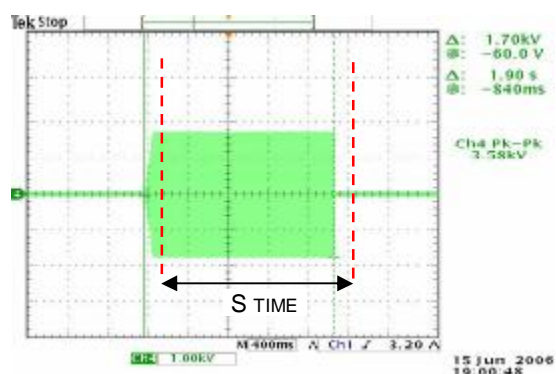

4. Lamp frequency may produce interference with horizontal synchronous frequency and as a result this may cause beat on the display. Therefore, lamp frequency shall be as away possible from the horizontal synchronous frequency and its harmonics range in order to prevent interference.
5. The brightness of the lamp after lighted for 5minutes is defined as 100%.
 T_s is the time required for the brightness of the center of the lamp to be not less than 95% at typical current. The screen of LCD module may be partially dark by the time the brightness of lamp is stable after turn on.
6. Maximum level of power consumption is measured at initial turn on.
 Typical level of power consumption is measured after 2hrs aging at $25 \pm 2^\circ\text{C}$.
7. The life time is determined as the time at which brightness of the lamp is 50% compared to that of initial value at the typical lamp current on condition of continuous operating at $25 \pm 2^\circ\text{C}$, based on duty 100%.
8. The output of the inverter must have symmetrical(negative and positive) voltage and current waveform (Unsymmetrical ratio is less than 10%). Please do not use the inverter which has not only unsymmetrical voltage and current but also spike wave.

Requirements for a system inverter design, which is intended to achieve better display performance, power efficiency and more reliable lamp characteristics.

It can help increase the lamp lifetime and reduce leakage current.

- a. The asymmetry rate of the inverter waveform should be less than 10%.
- b. The distortion rate of the waveform should be within $\sqrt{2} \pm 10\%$.

* Inverter output waveform had better be more similar to ideal sine wave.

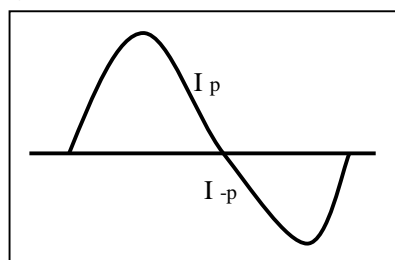

* Asymmetry rate:

$$|I_p - I_{-p}| / I_{op} \times 100\%$$

* Distortion rate

$$I_p \text{ (or } I_{-p}) / I_{op}$$

LC470WU5

Product Specification

9. The reference method of burst dimming duty ratio.

It is recommended to use synchronous V-sync frequency for prevent waterfall
(Vsync x 3 =Burst Frequency)

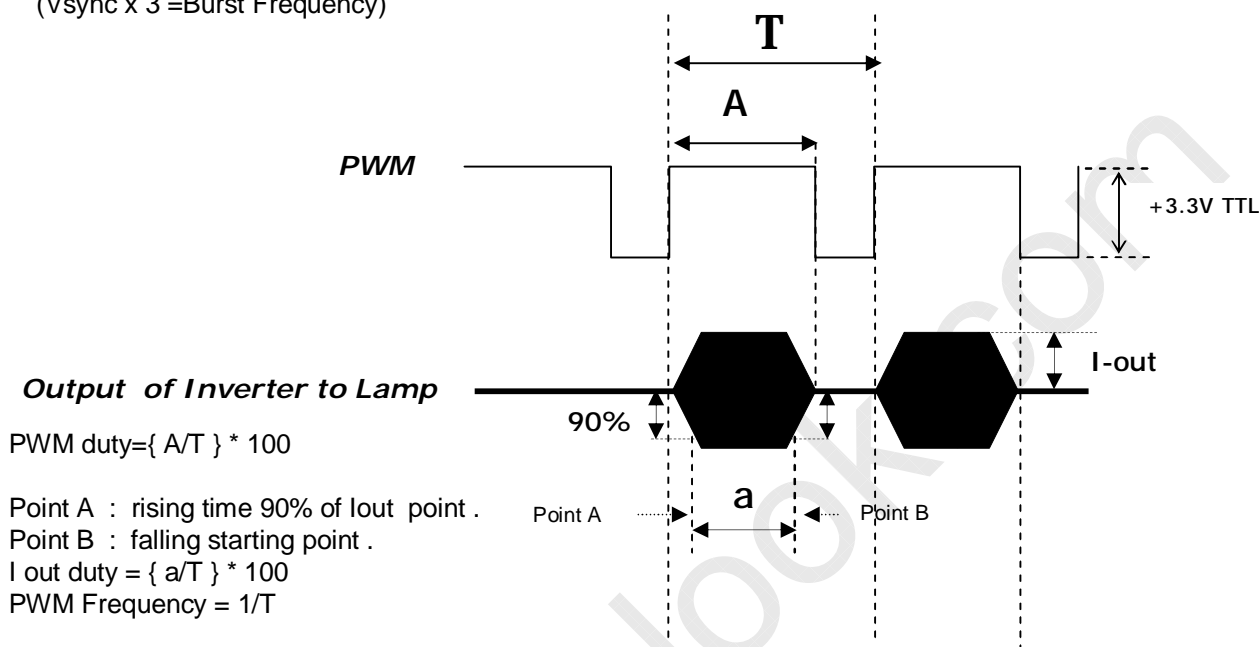

※ We recommend not to be much different between PWM duty and Iout duty .

※ Dimming current output rising and falling time may produce humming and inverter trans' sound noise.

※ Burst dimming duty should be 100% for 1second after turn on

※ Equipment

Oscilloscope : TDS3054B(Tektronix)

Current Probe : P6022 AC (Tektronix)

High Voltage Probe: P5100(Tektronix)

10. The Cable between the backlight connector and its inverter power supply should be connected directly with a minimized length. The longer cable between the backlight and the inverter may cause the lower luminance of lamp and may require more higher starting voltage (Vs).

11. The operating current must be measured as near as backlight assembly input.

12. The operating current unbalance between left and right must be under typ $\pm 10\%$.

13. C ballaster is as following

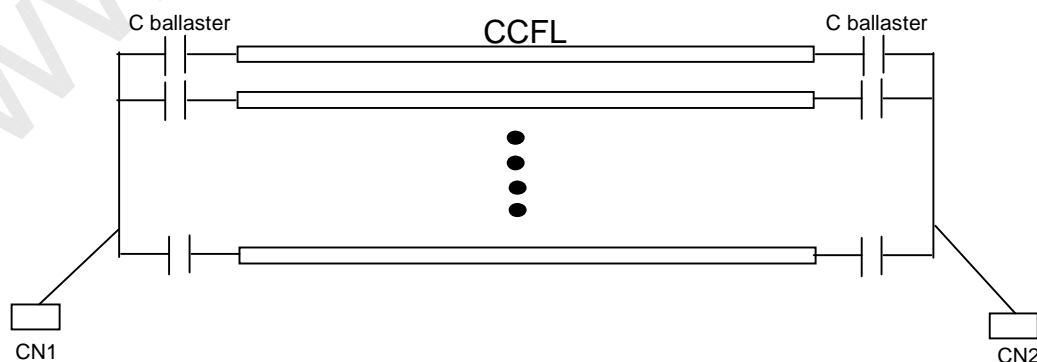

Product Specification

3-2. Interface Connections

This LCD module employs two kinds of interface connection, a 51-pin connector is used for the module electronics and two 3-pin Balance PCB connectors are used for the integral backlight system.

3-2-1. LCD Module

- LCD Connector(CN1): KN25-51P-0.5SH(manufactured by HIROSE) or Equivalent
- Mating Connector : FI-RE51HL(manufactured by JAE)

Table 4. MODULE CONNECTOR(CN1) PIN CONFIGURATION

No	Symbol	Description	No	Symbol	Description
1	Reserved(NC)	No connection	27	BIT Selection	Logic 'H' : 8Bit + FRC, 'L' : 8Bit
2	Reserved (NC)	No connection(Reserved for I ² C)	28	RE0N	SECOND CHANNEL 0-
3	Reserved (NC)	No connection(Reserved for I ² C)	29	RE0P	SECOND CHANNEL 0+
4	Reserved (NC)	No connection	30	RE1N	SECOND CHANNEL 1-
5	Reserved (NC)	No connection	31	RE1P	SECOND CHANNEL 1+
6	Reserved (NC)	No connection	32	RE2N	SECOND CHANNEL 2-
7	LVDS Select	Logic 'L' or NC':LG format,'H':DISM	33	RE2P	SECOND CHANNEL 2+
8	EXT VBR-B	EXT VBR-B Input	34	GND	Ground
9	VBR-OUT	DCR VBR-B Output	35	RECLKN	SECOND CLOCK CHANNEL C-
10	DCR Enable	Logic 'L' Level : Disable	36	RECLKP	SECOND CLOCK CHANNEL C+
11	GND	Ground	37	GND	Ground
12	RO0N	FIRST CHANNEL 0-	38	RE3N	SECOND CHANNEL 3-
13	RO0P	FIRST CHANNEL 0+	39	RE3P	SECOND CHANNEL 3+
14	RO1N	FIRST CHANNEL 1-	40	RE4N	SECOND CHANNEL 4-
15	RO1P	FIRST CHANNEL 1+	41	RE4P	SECOND CHANNEL 4+
16	RO2N	FIRST CHANNEL 2-	42	GND	Ground
17	RO2N	FIRST CHANNEL 2+	43	GND	Ground
18	GND	Ground	44	GND	Ground
19	ROCLKN	FIRST CLOCK CHANNEL C-	45	GND	Ground
20	ROCLKP	FIRST CLOCK CHANNEL C+	46	GND	Ground
21	GND	Ground	47	NC	NC
22	RO3N	FIRST CHANNEL 3-	48	VLCD	Power Supply +12.0V
23	RO3P	FIRST CHANNEL 3+	49	VLCD	Power Supply +12.0V
24	RO4N	FIRST CHANNEL 4-	50	VLCD	Power Supply +12.0V
25	RO4P	FIRST CHANNEL 4+	51	VLCD	Power Supply +12.0V
26	GND	Ground	-	-	-

Note : 1. All GND(ground) pins should be connected together to the LCD module's metal frame.

2. All VLCD (power input) pins should be connected together.

3. All Input levels of LVDS signals are based on the IEA 664 Standard.

4. Specific pins(pin No. #2~#6, #8~#10) are used for internal data process of the LCD module.

If not used, these pins are no connection.

LC470WU5

Product Specification

3-2-2. Backlight Module

[Master]

1) Balance Connector

: 65002WS-03 (manufactured by YEONHO) or equivalent

2) Mating Connector

: 65002HS-03 (manufactured by YEONHO) or equivalent.

[Slave]

1) Balance Connector

: 65002WS-03 (manufactured by YEONHO) or equivalent

2) Mating Connector

: 65002HS-03 (manufactured by YEONHO) or equivalent.

Table 5. BACKLIGHT CONNECTOR PIN CONFIGURATION(CN2,CN3)

No	Symbol	Master	Slave	Note
1	H_Input	High_Input	High_Input	
2	H_Input	High_Input	High_Input	
3	FB	NC	NC	

◆ Rear view of LCM

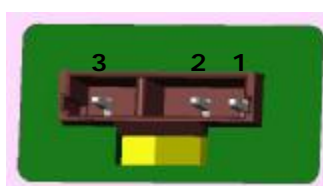

Master



Slave

3-2-3. Sync connection between LCD Module and System

There are 4 pins sync connector in the LCD module control PCB . The No.1 pin is for REFMODE which is selected of Vsync frequency signal. The No.2 pin is for WPWM which s generated for PWM frequency synchronically between control & inverter. The rest pins are for Ground and NC.

1) Inverter Sync Connector

: DF14-4S-1.25C (manufactured by Hirose) or equivalent

Table 6. INVERTER SYNC. CONNECTOR PIN CONFIGURATION(CN4)

Pin No.	Symbol	Description	Note
1	REFMODE	Vsync. Frequency select signal	
2	WPWM	PWM Frequency output	
3	GND	Ground	
4	NC	No connection	

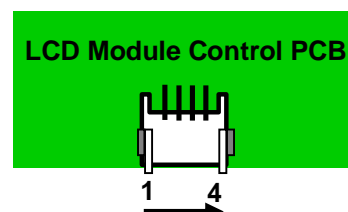

Notes:

1. LGD recommends that Inverter Burst dimming frequency (PWM Frequency) should be synchronized with Sync signal.
2. LGD recommends that Inverter Burst dimming frequency (PWM Frequency) should be 150Hz or 180Hz.

Product Specification

3-3. Signal Timing Specifications

Table 5 shows the signal timing required at the input of the LVDS transmitter. All of the interface signal timing should be satisfied with the following specification for normal operation.

Table 5. TIMING TABLE for NTSC (DE Only Mode)

ITEM	Symbol		Min	Typ	Max	Unit	Note
DCLK	Period	tCLK	12.99	13.47	14.29	ns	
	Frequency	-	70	74.25	77	MHz	=148.5/2
Hsync	Period	tHP	1060	1100	1280	tCLK	1
	Horizontal Valid	tHV	-	960	-	tCLK	
	Horizontal Blank	tHB	100	140	320		
	Frequency	fH	65.5	67.5	68.9	KHz	
	Width	tWH	12	30	60	tCLK	
	Horizontal Back Porch	tHBP	12	78	120		
	Horizontal Front Porch	tHFP	12	32	120		
Vsync	Period	tVP	1091	1125	1149	tHP	1
	Vertical Valid	tVV	-	1080	-	tHP	
	Vertical Blank	tVB	11	45	69	tHP	
	Frequency	fV	57	60	63	Hz	
	Width	tWV	4	5	10	tHP	
	Vertical Back Porch	tVBP	6	36	48		
	Vertical Front Porch	tVFP	2	4	10		

Note : 1. $t_{HB} = t_{HFP} + t_{WH} + t_{HBP}$

$t_{VB} = t_{VFP} + t_{WV} + t_{VBP}$

The Input of HSYNC & VSYNC signal does not have an effect on normal operation(DE Only Mode).

The performance of the electro-optical characteristics may be influenced by variance of the vertical refresh rate.

LC470WU5

Product Specification

Table 6 shows the signal timing required at the input of the LVDS transmitter. All of the interface signal timing should be satisfied with the following specification for normal operation.

Table 6. TIMING TABLE for PAL (DE Only Mode)

ITEM	Symbol		Min	Typ	Max	Unit	Note
DCLK	Period	tCLK	14.81	16.16	16.77	ns	
	Frequency	-	59.63	61.88	67.5	MHz	=123.75/2
Hsync	Period	tHP	1060	1100	1200	tCLK	1
	Horizontal Valid	tHV	-	960	-	tCLK	
	Horizontal Blank	tHB	100	140	240		
	Frequency	fH	55.25	56.25	57.25	KHz	
	Width	tWH	12	30	60	tCLK	
	Horizontal Back Porch	tHBP	12	78	120		
	Horizontal Front Porch	tHFP	12	32	120		
Vsync	Period	tVP	1105	1125	1145	tHP	1
	Vertical Valid	tVV	-	1080	-	tHP	
	Vertical Blank	tVB	25	45	65	tHP	
	Frequency	fV	47	50	53	Hz	
	Width	tWV	4	5	10	tHP	
	Vertical Back Porch	tVBP	6	36	45		
	Vertical Front Porch	tVFP	2	4	10		

Note : 1. $t_{HB} = t_{HFP} + t_{WH} + t_{HBP}$

$t_{VB} = t_{VFP} + t_{WV} + t_{VBP}$

The Input of HSYNC & VSYNC signal does not have an effect on normal operation(DE Only Mode).

The performance of the electro-optical characteristics may be influenced by variance of the vertical refresh rate.

Product Specification

3-4. Signal Timing Waveforms

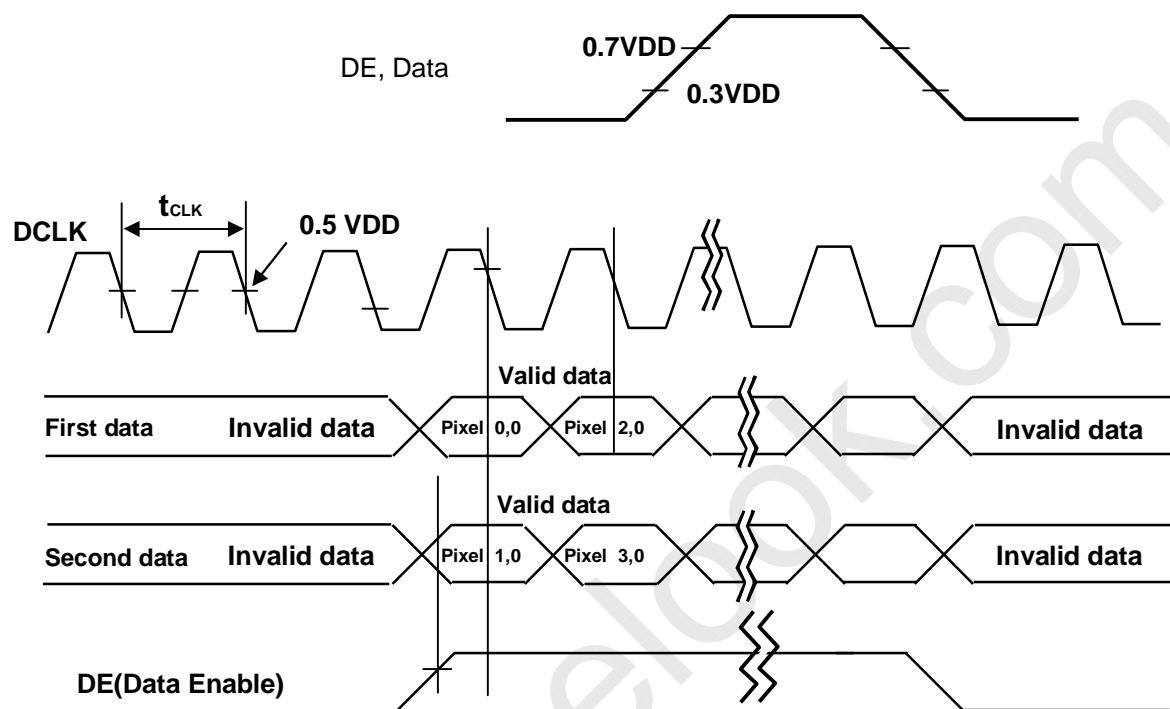

* Reference : Sync. Relation

$$* t_{HB} = t_{HFP} + t_{WH} + t_{HBP}$$

$$* t_{VB} = t_{VFP} + t_{VW} + t_{VBP}$$

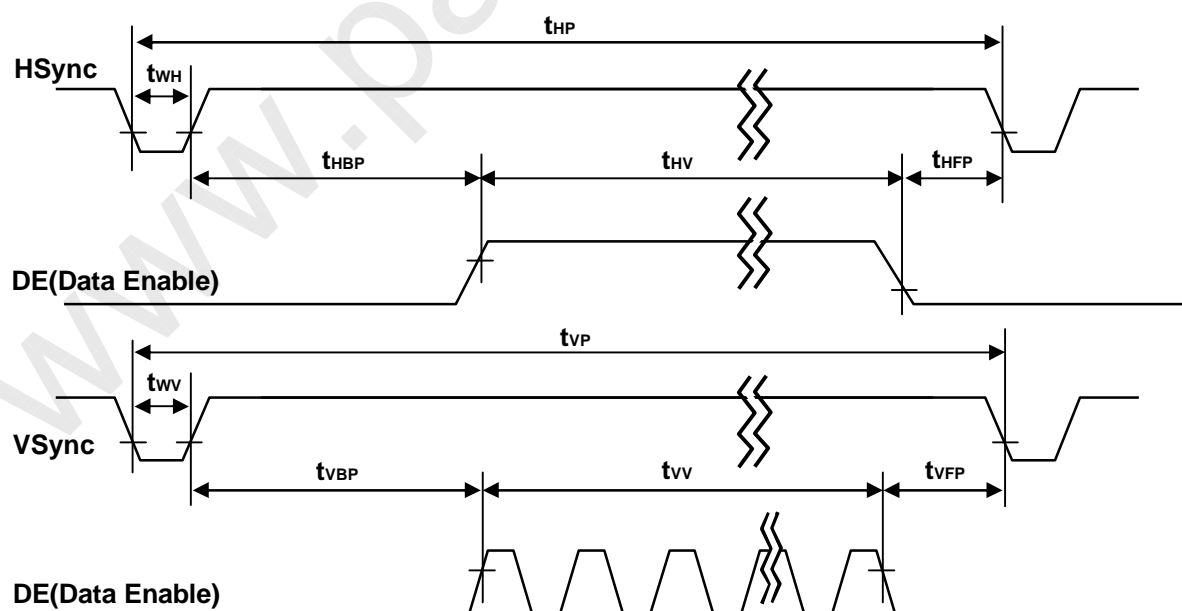

Product Specification

3-5. Color Data Reference

The brightness of each primary color(red,green,blue) is based on the 10-bit gray scale data input for the color. The higher binary input, the brighter the color. Table 7 provides a reference for color versus data input.

Table 7. COLOR DATA REFERENCE

Color		Input Color Data																													
		RED										GREEN										BLUE									
		MSB	LSB								MSB	LSB								MSB	LSB										
		R9	R8	R7	R6	R5	R4	R3	R2	R1	R0	G9	G8	G7	G6	G5	G4	G3	G2	G1	G0	B9	B8	B7	B6	B5	B4	B3	B2	B1	B0
Basic Color	Black	0	0	0	0	0	0	0	0	0	0	0	0	0	0	0	0	0	0	0	0	0	0	0	0	0	0	0	0	0	0
	Red (1023)	1	1	1	1	1	1	1	1	1	1	0	0	0	0	0	0	0	0	0	0	0	0	0	0	0	0	0	0	0	0
	Green (1023)	0	0	0	0	0	0	0	0	0	0	1	1	1	1	1	1	1	1	1	1	0	0	0	0	0	0	0	0	0	0
	Blue (1023)	0	0	0	0	0	0	0	0	0	0	0	0	0	0	0	0	0	0	0	0	1	1	1	1	1	1	1	1	1	1
	Cyan	0	0	0	0	0	0	0	0	0	0	1	1	1	1	1	1	1	1	1	1	1	1	1	1	1	1	1	1	1	1
	Magenta	1	1	1	1	1	1	1	1	1	1	0	0	0	0	0	0	0	0	0	0	1	1	1	1	1	1	1	1	1	1
	Yellow	1	1	1	1	1	1	1	1	1	1	1	1	1	1	1	1	1	1	1	1	0	0	0	0	0	0	0	0	0	0
	White	1	1	1	1	1	1	1	1	1	1	1	1	1	1	1	1	1	1	1	1	1	1	1	1	1	1	1	1	1	1
RED	RED (000)	0	0	0	0	0	0	0	0	0	0	0	0	0	0	0	0	0	0	0	0	0	0	0	0	0	0	0	0	0	
	RED (001)	0	0	0	0	0	0	0	0	0	0	0	0	0	0	0	0	0	0	0	0	0	0	0	0	0	0	0	0	0	
									
	RED (1022)	1	1	1	1	1	1	1	1	1	0	0	0	0	0	0	0	0	0	0	0	0	0	0	0	0	0	0	0	0	0
	RED (1023)	1	1	1	1	1	1	1	1	1	1	0	0	0	0	0	0	0	0	0	0	0	0	0	0	0	0	0	0	0	0
GREEN	GREEN (000)	0	0	0	0	0	0	0	0	0	0	0	0	0	0	0	0	0	0	0	0	0	0	0	0	0	0	0	0	0	
	GREEN (001)	0	0	0	0	0	0	0	0	0	0	0	0	0	0	0	0	0	0	1	0	0	0	0	0	0	0	0	0	0	
									
	GREEN (1022)	0	0	0	0	0	0	0	0	0	0	1	1	1	1	1	1	1	1	1	0	0	0	0	0	0	0	0	0	0	0
	GREEN (1023)	0	0	0	0	0	0	0	0	0	0	1	1	1	1	1	1	1	1	1	1	0	0	0	0	0	0	0	0	0	0
BLUE	BLUE (000)	0	0	0	0	0	0	0	0	0	0	0	0	0	0	0	0	0	0	0	0	0	0	0	0	0	0	0	0	0	
	BLUE (001)	0	0	0	0	0	0	0	0	0	0	0	0	0	0	0	0	0	0	0	0	0	0	0	0	0	0	0	0	1	
									
	BLUE (1022)	0	0	0	0	0	0	0	0	0	0	0	0	0	0	0	0	0	0	0	0	1	1	1	1	1	1	1	1	1	0
	BLUE (1023)	0	0	0	0	0	0	0	0	0	0	0	0	0	0	0	0	0	0	0	0	1	1	1	1	1	1	1	1	1	1

Product Specification

3-6. Power Sequence

3-6-1. LCD Driving circuit

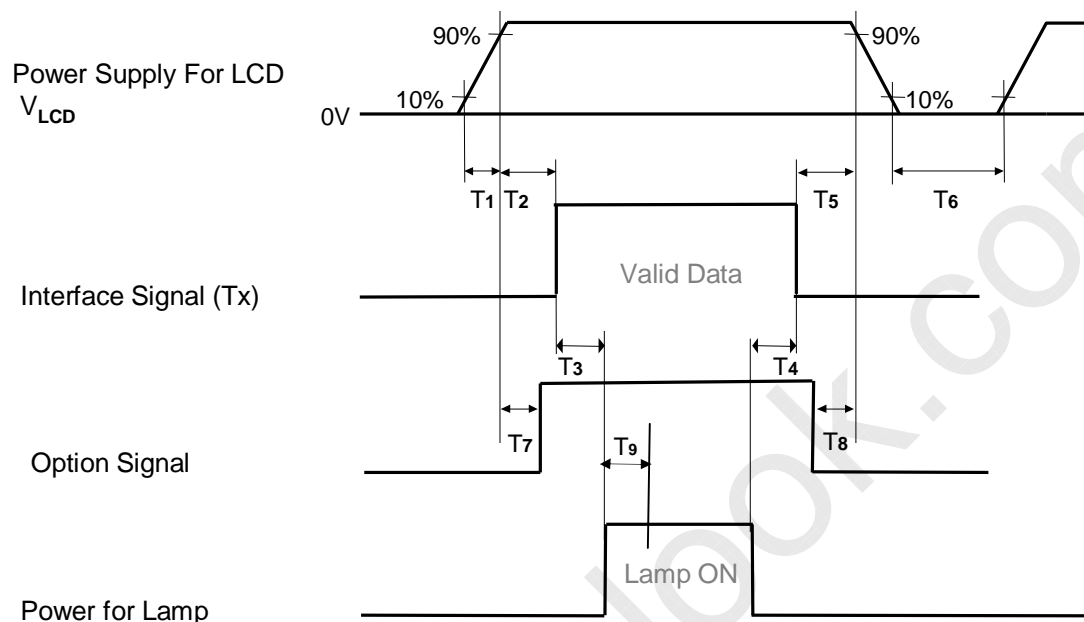

* Burst Dimming Duty : 100% & Iop : Typical Current

Table 8. POWER SEQUENCE

Parameter	Value			Unit
	Min	Typ	Max	
T1	0.5	-	20	ms
T2	0.5	-	50	ms
T3	200	-	-	ms
T4	200	-	-	ms
T5	0.5	-	50	ms
T6	1.0	-	-	s
T7	0 < T7 < T2			ms
T8	0 < T8 < T5			ms
T9	1000	-	-	ms

- Note :
1. Please avoid floating state of interface signal at invalid period.
 2. When the interface signal is invalid, be sure to pull down the power supply V_{LCD} to 0V.
 3. Flicker would come out when power on-off ($T7$ =under 2s) is tested over several ten-times.
 4. The case when the T2/T5 exceed maximum specification, it operates protection pattern(Black pattern) till valid signal inputted. There is no reliability problem.
 5. The T3/T4 is recommended value, the case when failed to meet a minimum specification, abnormal display would be shown. There is no reliability problem.

LC470WU5

Product Specification

4. Optical Specification

Optical characteristics are determined after the unit has been 'ON' and stable in a dark environment at $25\pm 2^{\circ}\text{C}$. The values specified are at an approximate distance 50cm from the LCD surface at a viewing angle of Φ and θ equal to 0° .

FIG. 1 shows additional information concerning the measurement equipment and method.

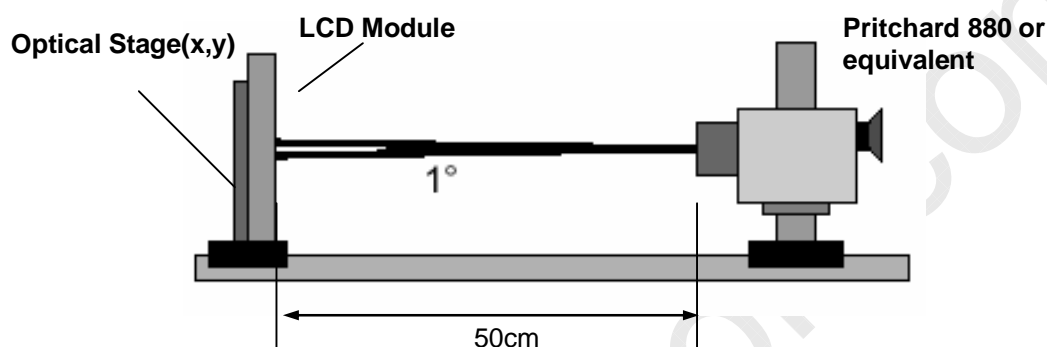

FIG. 1 Optical Characteristic Measurement Equipment and Method

Table 9. OPTICAL CHARACTERISTICS

 $T_a = 25\pm 2^{\circ}\text{C}$, $V_{\text{LCD}} = 12.0\text{V}$, $f_v = 60\text{Hz}$, $D_{\text{clk}} = 148.5\text{MHz}$, $I_{\text{BL}} = 145\text{mA}_{\text{rms}}$

Parameter	Symbol	Value			Unit	Note	
		Min	Typ	Max			
Contrast Ratio	CR	700	900	-		1	
Surface Luminance, white	L_{WH}	400	500		cd/m^2	2	
Luminance Variation	δ_{WHITE} 5P			1.3		3	
Response Time (Gray-to-Gray)	$T_{\text{R}}, T_{\text{D}}$		8	16	ms	4	
Color Coordinates [CIE1931]	RED	R_x		0.638			
		R_y		0.340			
	GREEN	G_x		0.279			
		G_y	Typ -0.03	0.611	Typ +0.03		
	BLUE	B_x		0.146			
		B_y		0.062			
	WHITE	W_x		0.279			
		W_y		0.292			
Viewing Angle (CR>10)							
	x axis, right ($\phi=0^{\circ}$)	θ_r	89	-	-	degree	5
	x axis, left ($\phi=180^{\circ}$)	θ_l	89	-	-		
	y axis, up ($\phi=90^{\circ}$)	θ_u	89	-	-		
	y axis, down ($\phi=270^{\circ}$)	θ_d	89	-	-		
Gray Scale			2.2			6	

LC470WU5

Product Specification

Note :1. Contrast Ratio(CR) is defined mathematically as :

$$CR(\text{Contrast Ratio}) = \text{Maximum CR}_n (n=1, 2, 3, 4, 5)$$

$$CR_n = \frac{\text{Surface Luminance at position } n \text{ with all white pixels}}{\text{Surface Luminance at position } n \text{ with all black pixels}}$$

n = the Position number(1, 2, 3, 4, 5). For more information, see FIG 2.

2. Surface luminance are determined after the unit has been 'ON' and 30min after lighting the backlight in a dark environment at $25 \pm 2^\circ\text{C}$. Surface luminance is the luminance value at center 1-point across the LCD surface 50cm from the surface with all pixels displaying white. For more information see the FIG. 2.

3. The variation in surface luminance , δ WHITE is defined as :

$$\delta \text{ WHITE}(5P) = \text{Maximum}(L_{on1}, L_{on2}, L_{on3}, L_{on4}, L_{on5}) / \text{Minimum}(L_{on1}, L_{on2}, L_{on3}, L_{on4}, L_{on5})$$

Where L_{on1} to L_{on5} are the luminance with all pixels displaying white at 5 locations . For more information, see the FIG. 2.

4. Response time is the time required for the display to transition from G(N) to G(M) (Rise Time, Tr_R) and from G(M) to G(N) (Decay Time, Tr_D). For additional information see the FIG. 3. ($N < M$)

5. Viewing angle is the angle at which the contrast ratio is greater than 10. The angles are determined for the horizontal or x axis and the vertical or y axis with respect to the z axis which is normal to the LCD module surface. For more information, see the FIG. 4.

6. Gray scale specification

Gamma Value is approximately 2.2. For more information, see the Table 10.

Table 10. GRAY SCALE SPECIFICATION

Gray Level	Luminance [%] (Typ.)
L0	0.16
L63	0.33
L127	0.96
L191	2.36
L255	4.67
L319	7.95
L383	12.21
L447	17.19
L511	22.5
L575	28.86
L639	36.48
L703	44.1
L767	54.26
L831	64.42
L895	75.32
L959	87.3
L1023	100

LC470WU5

Product Specification

Measuring point for surface luminance & measuring point for luminance variation.

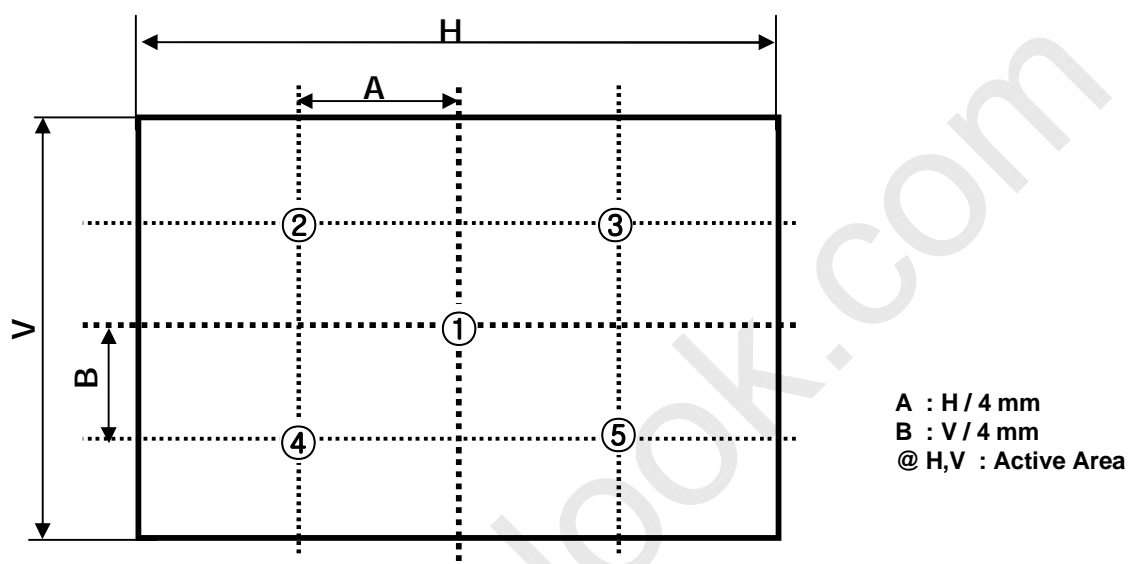

FIG. 2 5 Points for Luminance Measure

Response time is defined as the following figure and shall be measured by switching the input signal for "Gray(N)" and "Gray(M)".

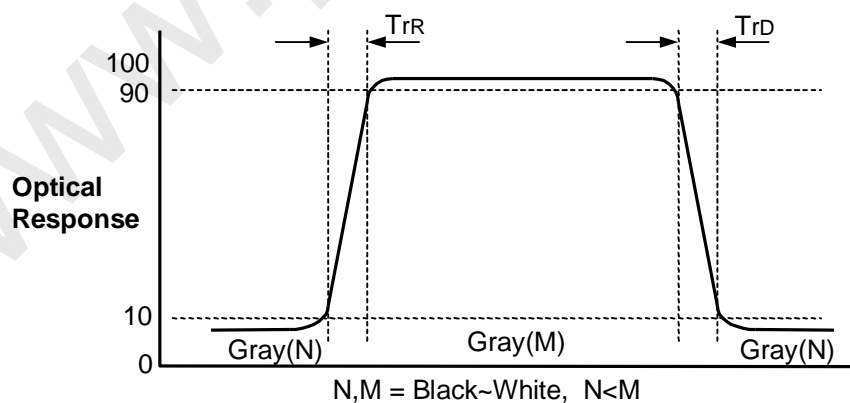

FIG. 3 Response Time

LC470WU5

Product Specification

Dimension of viewing angle range

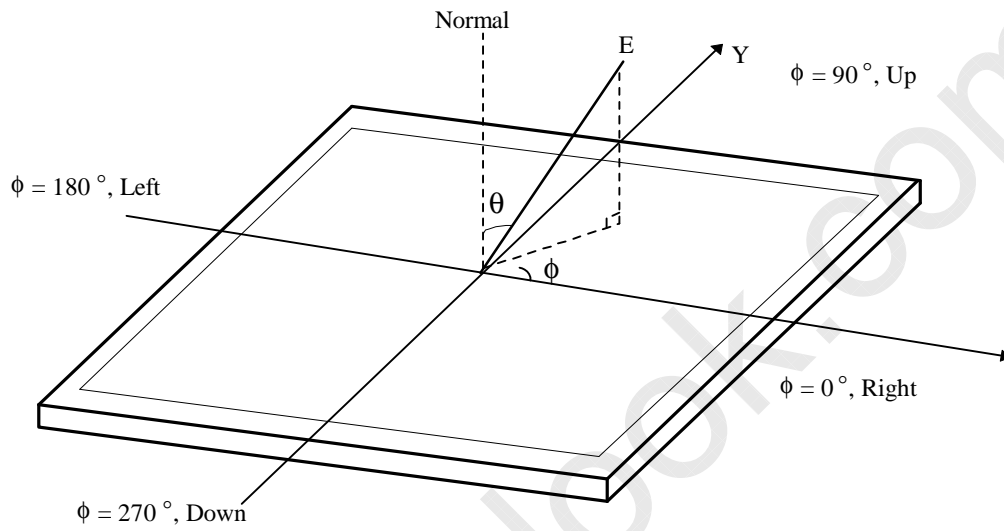

FIG. 4 Viewing Angle

LC470WU5

Product Specification

5. Mechanical Characteristics

Table 11 provides general mechanical characteristics.

Table 11. MECHANICAL CHARACTERISTICS

Item	Value	
Outline Dimension	Horizontal	1096.0 mm
	Vertical	640.0 mm
	Depth	51.0 mm
Bezel Area	Horizontal	1049.0 mm
	Vertical	593.0 mm
Active Display Area	Horizontal	1039.68 mm
	Vertical	584.82 mm
Weight	14.5 Kg (Typ.)	

Note : Please refer to a mechanic drawing in terms of tolerance at the next page.



LC470WU5

Product Specification

<FRONT VIEW>

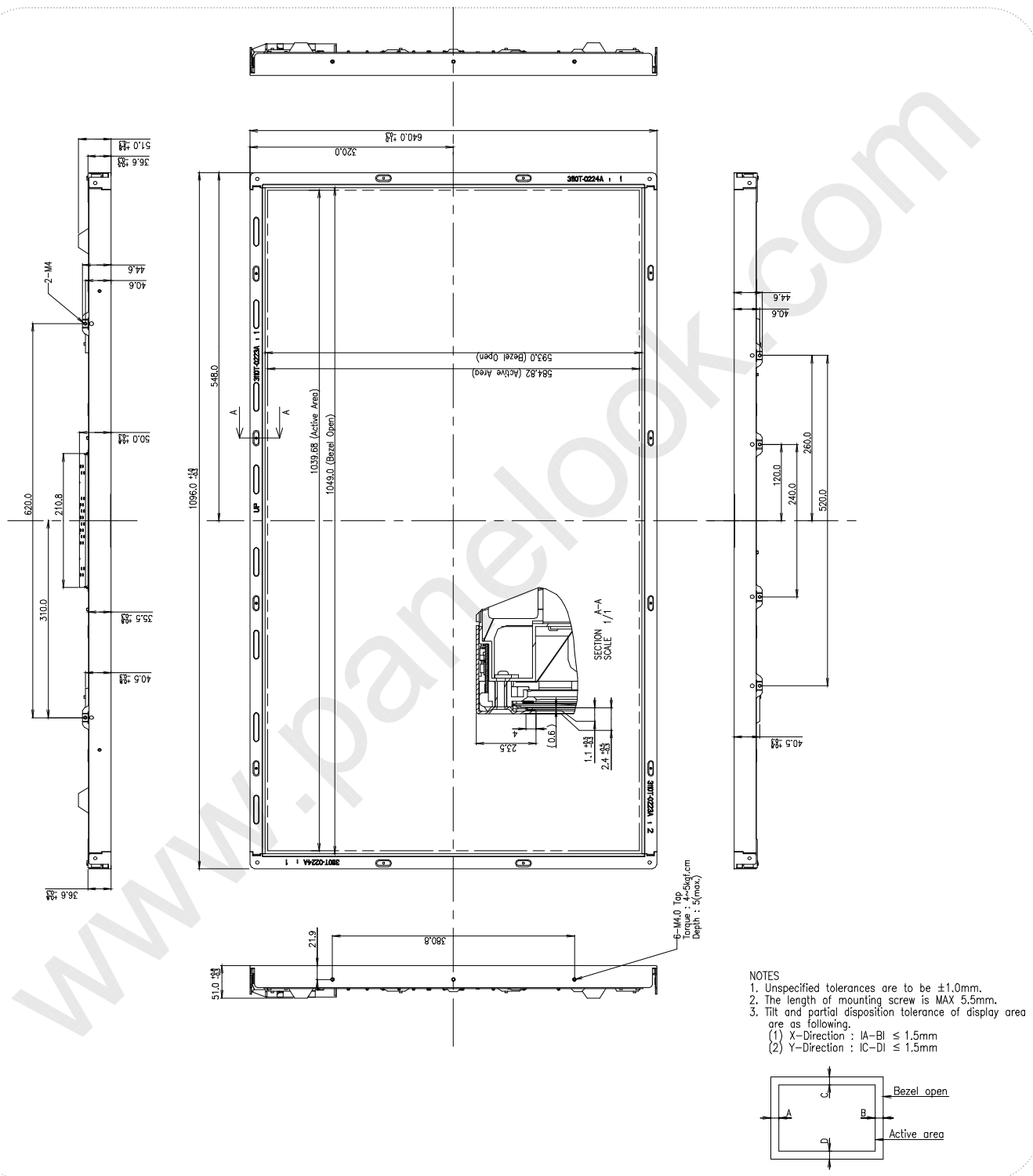

Ver. 1.0

22 / 35

LC470WU5

Product Specification

<REAR VIEW>

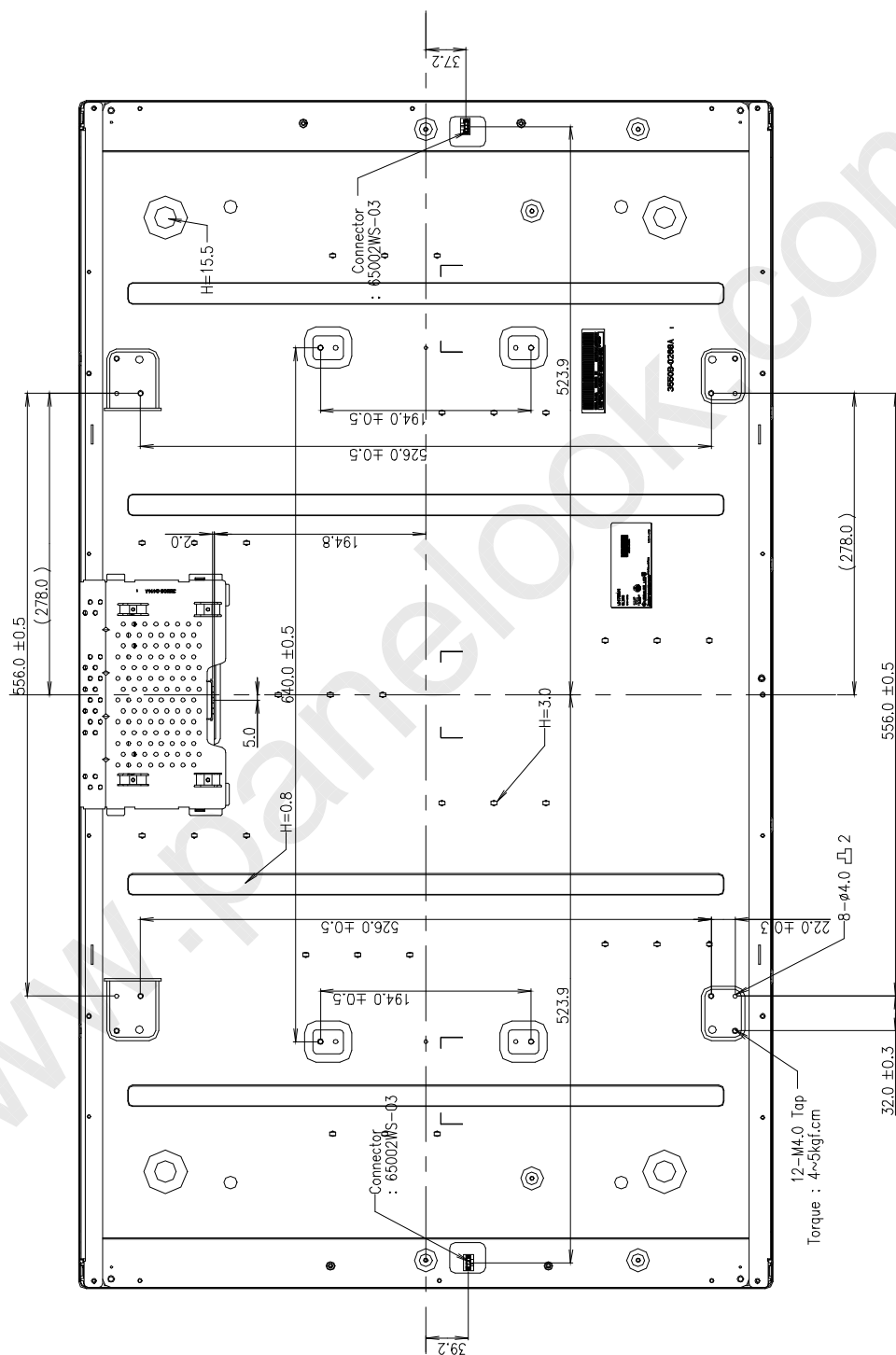

Ver. 1.0

23 / 35

LC470WU5

Product Specification

6. Reliability**Table 12. ENVIRONMENT TEST CONDITION**

No.	Test Item	Condition
1	High temperature storage test	Ta= 50°C 240h
2	Low temperature storage test	Ta= -20°C 240h
3	High temperature operation test	Ta= 50°C 50%RH 240h
4	Low temperature operation test	Ta= 0°C 240h
5	Vibration test (non-operating)	Wave form : random Vibration level : 1.0G RMS Bandwidth : 10-300Hz Duration : 30 min for X,Y,Z axis One time each direction
6	Shock test (non-operating)	Shock level :50G(X,Y axis) , 35G(Z axis) Waveform : half sine wave, 11ms Direction : ±X, ±Y, ±Z One time each direction
7	Humidity condition Operation	Ta= 40 °C, 90%RH
8	Altitude operating storage / shipment	0 - 14,000 feet(4267.2m) 0 - 40,000 feet(12192m)

Product Specification

7. International Standards

7-1. Safety

- a) UL 60065, 7th Edition, dated June 30, 2003, Underwriters Laboratories, Inc., Standard for Audio, Video and Similar Electronic Apparatus.
- b) CAN/CSA C22.2, No. 60065:03, Canadian Standards Association, Standard for Audio, Video and Similar Electronic Apparatus.
- c) IEC60065:2001, 7th Edition CB-scheme and EN 60065:2002, Safety requirements for Audio, Video and Similar Electronic Apparatus..

7-2. EMC

- a) ANSI C63.4 "Methods of Measurement of Radio-Noise Emissions from Low-Voltage Electrical and Electrical Equipment in the Range of 9kHz to 40GHz. "American National Standards Institute(ANSI), 1992
- b) CISPR13 "Limits and Methods of Measurement of Radio interference characteristics of Sound and Television broadcast receivers and associated equipment"
CISPR22 "Limits and Methods of Measurement of Radio interference characteristics of Information Technology Equipment" International Special Committee on Radio Interference.
- c) EN55013 "Limits and Methods of Measurement of Radio interference characteristics of Sound and Television broadcast receivers and associated equipment"
EN55022 "Limits and Methods of Measurement of Radio interference characteristics of Information Technology Equipment" European Committee for Electro Technical Standardization.(CENELEC), 1988(Including A1:2000)

LC470WU5

Product Specification

8. Packing**8-1. Designation of Lot Mark**

a) Lot Mark

A	B	C	D	E	F	G	H	I	J	K	L	M
---	---	---	---	---	---	---	---	---	---	---	---	---

A,B,C : SIZE(INCH)
E : MONTH

D : YEAR
F ~ M : SERIAL NO.

Note

1. YEAR

Year	2001	2002	2003	2004	2005	2006	2007	2008	2009	2010
Mark	1	2	3	4	5	6	7	8	9	0

2. MONTH

Month	Jan	Feb	Mar	Apr	May	Jun	Jul	Aug	Sep	Oct	Nov	Dec
Mark	1	2	3	4	5	6	7	8	9	A	B	C

b) Location of Lot Mark

Serial No. is printed on the label. The label is attached to the backside of the LCD module.
This is subject to change without prior notice.

8-2. Packing Form

a) Package quantity in one pallet : 14 pcs

b) Pallet Size : 1220mm X 1140mm X 860mm

Product Specification

9. Precautions

Please pay attention to the followings when you use this TFT LCD module.

9-1. Mounting Precautions

- (1) You must mount a module using holes arranged in four corners or four sides.
- (2) You should consider the mounting structure so that uneven force (ex. Twisted stress) is not applied to the module. And the case on which a module is mounted should have sufficient strength so that external force is not transmitted directly to the module.
- (3) Please attach the surface transparent protective plate to the surface in order to protect the polarizer. Transparent protective plate should have sufficient strength in order to resist external force.
- (4) You should adopt radiation structure to satisfy the temperature specification.
- (5) Acetic acid type and chlorine type materials for the cover case are not desirable because the former generates corrosive gas of attacking the polarizer at high temperature and the latter causes circuit break by electro-chemical reaction.
- (6) Do not touch, push or rub the exposed polarizers with glass, tweezers or anything harder than HB pencil lead. And please do not rub with dust clothes with chemical treatment. Do not touch the surface of polarizer for bare hand or greasy cloth. (Some cosmetics are detrimental to the polarizer.)
- (7) When the surface becomes dusty, please wipe gently with absorbent cotton or other soft materials like chamois soaks with petroleum benzene. Normal-hexane is recommended for cleaning the adhesives used to attach front / rear polarizers. Do not use acetone, toluene and alcohol because they cause chemical damage to the polarizer.
- (8) Wipe off saliva or water drops as soon as possible. Their long time contact with polarizer causes deformations and color fading.
- (9) Do not open the case because inside circuits do not have sufficient strength.

9-2. Operating Precautions

- (1) The spike noise causes the mis-operation of circuits. It should be lower than following voltage :
 $V = \pm 200\text{mV}$ (Over and under shoot voltage)
- (2) Response time depends on the temperature. (In lower temperature, it becomes longer.)
- (3) Brightness depends on the temperature. (In lower temperature, it becomes lower.)
And in lower temperature, response time (required time that brightness is stable after turned on) becomes longer.
- (4) Be careful for condensation at sudden temperature change. Condensation makes damage to polarizer or electrical contacted parts. And after fading condensation, smear or spot will occur.
- (5) When fixed patterns are displayed for a long time, remnant image is likely to occur.
- (6) Module has high frequency circuits. Sufficient suppression to the electromagnetic interference shall be done by system manufacturers. Grounding and shielding methods may be important to minimize the interference.
- (7) Please do not give any mechanical and/or acoustical impact to LCM. Otherwise, LCM can't be operated its full characteristics perfectly.
- (8) A screw which is fastened up the steels should be a machine screw.
(if not, it causes metallic foreign material and deal LCM a fatal blow)
- (9) Please do not set LCD on its edge.

Product Specification

9-3. Electrostatic Discharge Control

Since a module is composed of electronic circuits, it is not strong to electrostatic discharge. Make certain that treatment persons are connected to ground through wrist band etc. And don't touch interface pin directly.

9-4. Precautions for Strong Light Exposure

Strong light exposure causes degradation of polarizer and color filter.

9-5. Storage

When storing modules as spares for a long time, the following precautions are necessary.

- (1) Store them in a dark place. Do not expose the module to sunlight or fluorescent light. Keep the temperature between 5°C and 35°C at normal humidity.
- (2) The polarizer surface should not come in contact with any other object.
It is recommended that they be stored in the container in which they were shipped.

9-6. Handling Precautions for Protection Film

- (1) The protection film is attached to the bezel with a small masking tape.
When the protection film is peeled off, static electricity is generated between the film and polarizer.
This should be peeled off slowly and carefully by people who are electrically grounded and with well ion-blown equipment or in such a condition, etc.
- (2) When the module with protection film attached is stored for a long time, sometimes there remains a very small amount of glue still on the bezel after the protection film is peeled off.
- (3) You can remove the glue easily. When the glue remains on the bezel surface or its vestige is recognized, please wipe them off with absorbent cotton waste or other soft material like chamois soaked with normal-hexane.

LC470WU5

Product Specification

APPENDIX- I-1

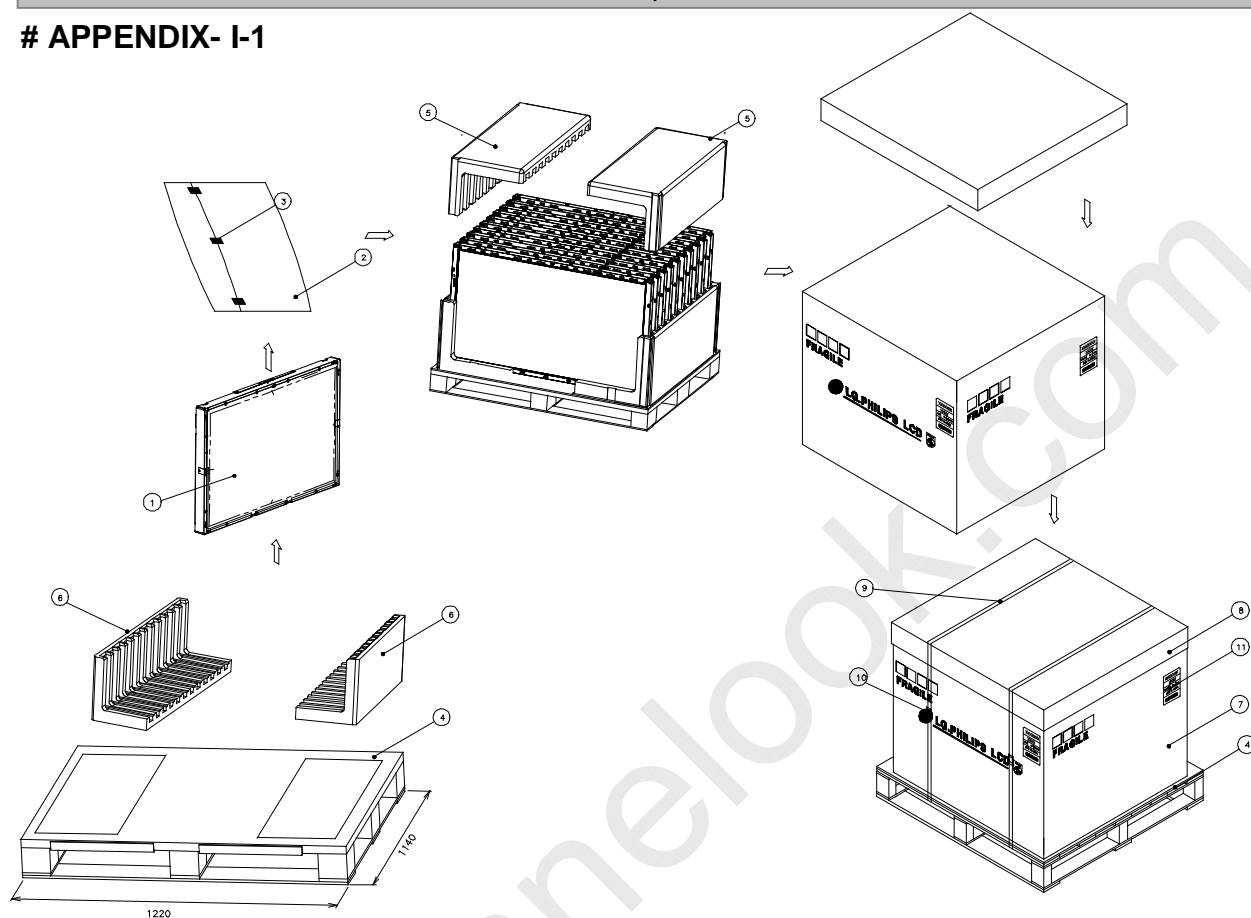

NO.	DESCRIPTION	MATERIAL
1	LCD Module	
2	BAG	47INCH
3	TAPE	MASKING 20MM X 50M
4	PALLET	PAPER 1220X1140X130MM
5	PACKING, TOP	EPS
6	PACKING, BOTTOM	EPS
7	ANGLE PACKING	PAPER
8	ANGLE COVER	PAPER
9	BAND	PP
10	BAND, CLIP	STEEL
11	LABEL	YUPO PAPER 80G 100X100

LC470WU5

APPENDIX- I-2

■ LCM Label



■ Serial No. (See CAS 26page for more information)

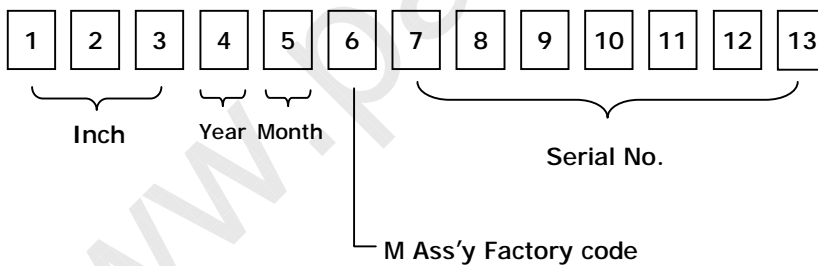



LC470WU5

APPENDIX- I-3

■ Pallet Label

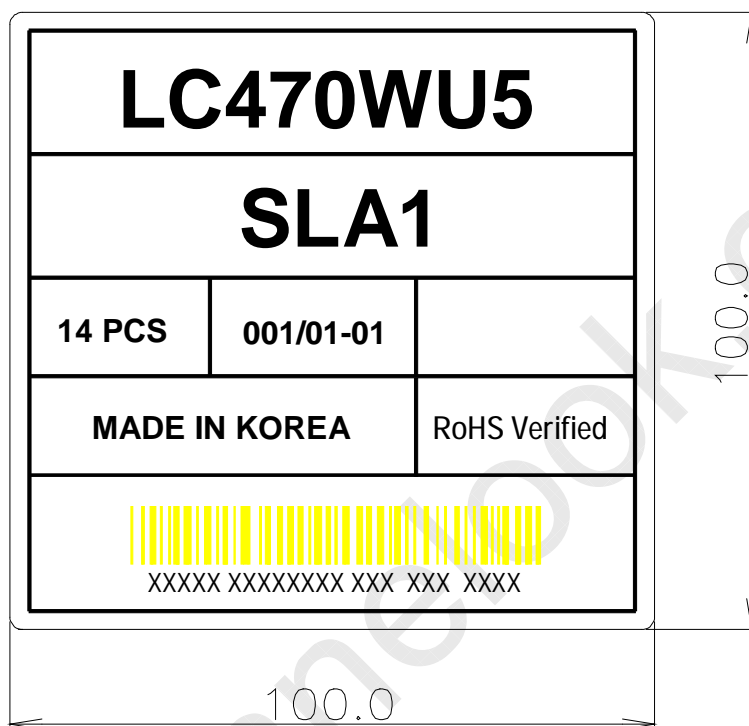

Product Specification

APPENDIX-II-1

■ Required signal assignment for Flat Link (Thine : THC63LVD103) Transmitter(Pin7="L")

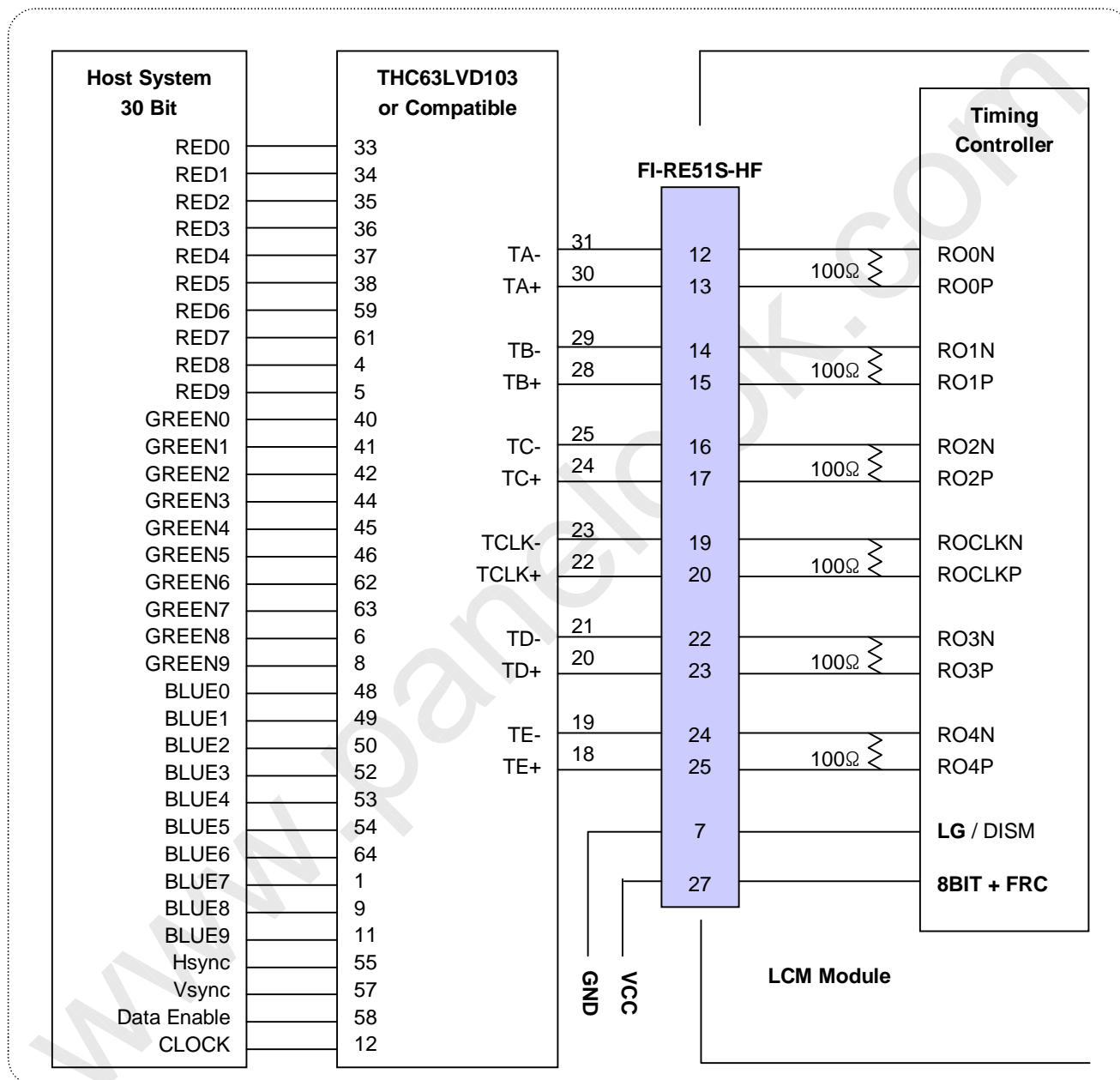

Notes:

1. The LCD module uses a 100 Ohm(Ω) resistor between positive and negative lines of each receiver input.
2. Refer to LVDS transmitter data sheet for detail descriptions. (THC63LVD103 or Compatible)
3. '7' means MSB and '0' means LSB at R,G,B pixel data.

APPENDIX- III

LVDS Data-Mapping info. (10bit)

■ LVDS Select : "H" Data-Mapping (DISM format)

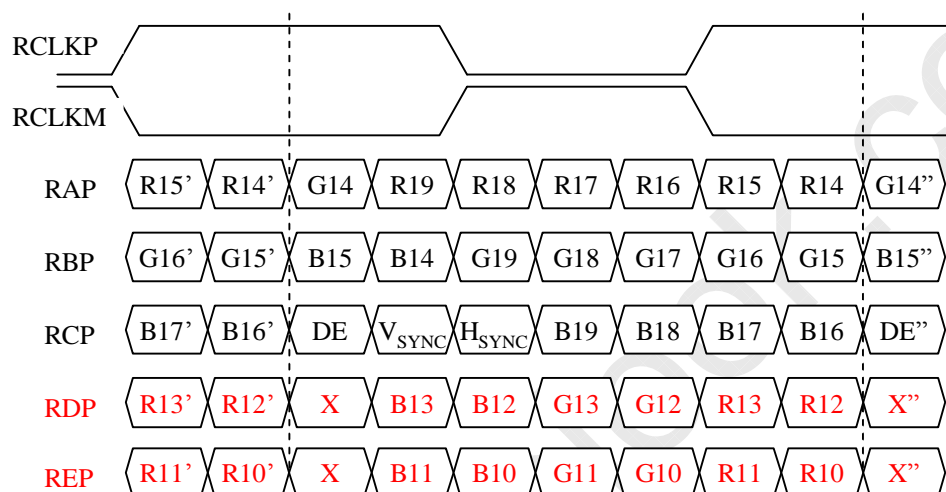

■ LVDS Select : "L" Data-Mapping (LG format)

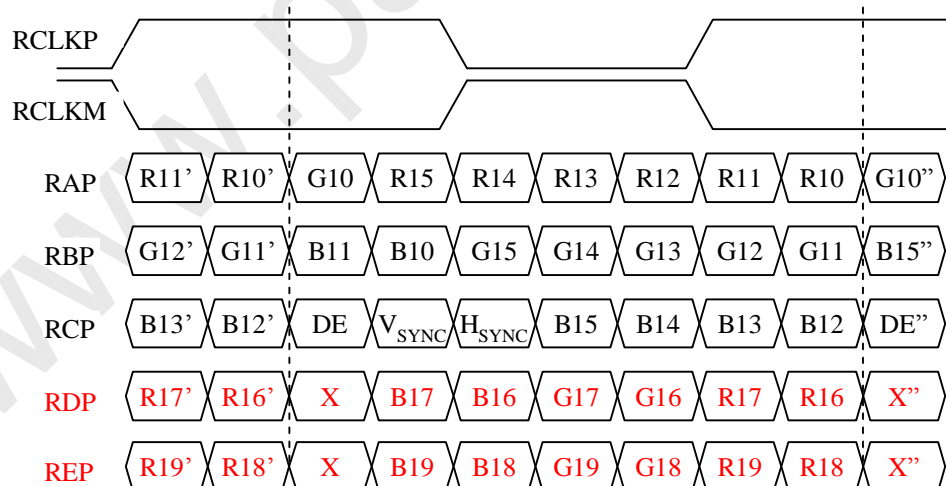

LC470WU5

Product Specification

APPENDIX-IV

■ Lamp Electrical spec

	Item	Unit	Standards	Notes
1	Lamp Voltage V_L	Vrms	1,780 $\pm 10\%$ IL= 3.0mA 1,600 $\pm 10\%$ IL= 6.0mA 1,450 $\pm 10\%$ IL= 8.0mA	Note1,3
2	Lamp Current I_L	mArms	Min 3.0 Typ 6.0 Max 8.0	Note1,3
3	Lamp power $V_L \times I_L$	W	5.34 IL=3.0mA 9.60 IL=6.0mA 11.6 IL=8.0mA	Note1,3
4	Starting Voltage V_s	Vrms	Max 3,000 (0°C) (Max 3,200) Max 2,500 (25°C) (Max 2,700)	Note2
5	Average Luminance at Lamp Center L	Cd/m ²	10,500 $\pm 10\%$ IL=3.0mA 23,000 $\pm 10\%$ IL=6.0mA 28,000 $\pm 10\%$ IL=8.0mA	Note1,3,4
6	Effective Light Emitting Area $L \times E$	mm	1030 Min	Note1,3
7	Luminance uniformity lighted after 45 seconds	%	80 Min	Note3,5
8	Color Coordinates	x y	0.241 ± 0.013 0.207 ± 0.013	Note1,3,4
9	Color Temperature(reference)	K	Impossibility	Note1,3
10	Peak spectrum (reference)	nm	Red 611 Green 543 Blue 450	
11	Discharge Stabilization Time	Second	100	Note3,6
12	Delayed Discharge Time	Second	1.0	Note7
13	Operating Frequency	kHz	40~48(Typ)~80	Note8
14	Life Time	Hours	Min 50,000(at 6.0mA) Ave 55,000(at 6.0mA)	7. Life (2)
15	Temperature difference of between the electrode	°C	10 Max	Note1,3,9
16	Lamp surface temperature	°C	170 Max(at electrode) 70 Max(at center)	Note1,3
17	Content of Mercury	mg	Min 2.5 Max 4.8	
18	Gas pressure	Torr	Typ 60	Note3
19	$\Delta u, v$		Max0.005	Note1,3,4