

Product Specification

SPECIFICATION FOR APPROVAL

- () Preliminary Specification
- (●) Final Specification

Title	47.0" WUXGA TFT LCD
-------	---------------------

BUYER	General
MODEL	

SUPPLIER	LG Display Co., Ltd.
*MODEL	LC470WUD
SUFFIX	SBT1(RoHS Verified)

*When you obtain standard approval, please use the above model name without suffix

APPROVED BY	SIGNATURE DATE
/	_____
/	_____
/	_____

Please return 1 copy for your confirmation with your signature and comments.

APPROVED BY	SIGNATURE DATE
J.T.Kim / Team Leader	_____
REVIEWED BY	
P.Y. Kim / Project Leader	_____
PREPARED BY	
H.J. Kim / Engineer	_____

**TV Product Development Dept.
LG Display Co., Ltd**

Product Specification

CONTENTS

Number	ITEM	Page
	COVER	1
	CONTENTS	2
	RECORD OF REVISIONS	3
1	GENERAL DESCRIPTION	4
2	ABSOLUTE MAXIMUM RATINGS	5
3	ELECTRICAL SPECIFICATIONS	6
3-1	ELECTRICAL CHARACTERISTICS	6
3-2	INTERFACE CONNECTIONS	10
3-3	SIGNAL TIMING SPECIFICATIONS	12
3-4	SIGNAL TIMING WAVEFORMS	14
3-5	COLOR DATA REFERENCE	15
3-6	POWER SEQUENCE	16
4	OPTICAL SPECIFICATIONS	17
5	MECHANICAL CHARACTERISTICS	22
6	RELIABILITY	24
7	INTERNATIONAL STANDARDS	25
7-1	SAFETY	25
7-2	EMC	25
8	PACKING	26
8-1	Information of LCM Label	26
8-2	PACKING FORM	26
9	PRECAUTIONS	27
9-1	MOUNTING PRECAUTIONS	27
9-2	OPERATING PRECAUTIONS	27
9-3	ELECTROSTATIC DISCHARGE CONTROL	28
9-4	PRECAUTIONS FOR STRONG LIGHT EXPOSURE	28
9-5	STORAGE	28
9-6	HANDLING PRECAUTIONS FOR PROTECTION FILM	28

Product Specification

1. General Description

LC470WUD is a Color Active Matrix Liquid Crystal Display with an Cold Cathode Fluorescent Lamp(CCFL) backlight system. The matrix employs a-Si Thin Film Transistor as the active element. It is a transmissive type display operating in the normally black mode. It has a 46.96 inch diagonally measured active display area with WUXGA resolution (1080 vertical by 1920 horizontal pixel array) Each pixel is divided into Red, Green and Blue sub-pixels or dots which are arranged in vertical stripes. Gray scale or the luminance of the sub-pixel color is determined with a 10-bit gray scale signal for each dot, thus presenting a palette of more than 1.06Billion(FRC) of colors.

It has been designed to apply the 10-bit 4 port LVDS interface.

It is intended to support LCD TV, PCTV where high brightness, super wide viewing angle, high color gamut, high color depth and fast moving picture response time are important.

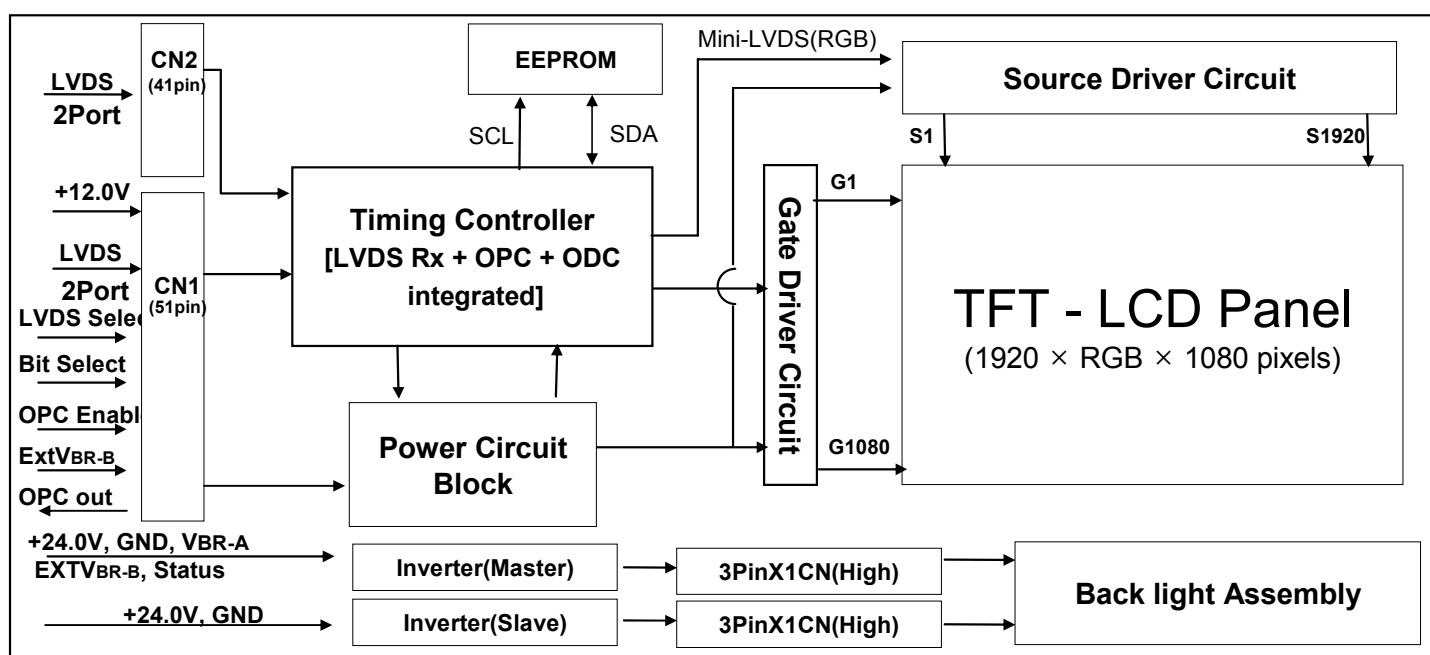

General Features

Active Screen Size	46.96 inch (1192.87mm) diagonal
Outline Dimension	1075.6(H) x 620.8 (V) x 33.8 mm (D) (Typ.)
Pixel Pitch	0.5415 mm x 0.5415 mm x RGB
Pixel Format	1920 horiz. by 1080 vert. Pixels, RGB stripe arrangement
Color Depth	10Bit(D), 1.06 Billion colors
Luminance, White	500 cd/m ² (Center 1 point ,Typ.)
Viewing Angle (CR>10)	Viewing angle free (R/L 178 (Min.), U/D 178 (Min.))
Power Consumption	Total 221W (Typ.) (Logic= 8.06W, Inverter=213W [VBR-A=1.65V])
Weight	14.5 Kg (Typ.)
Display Mode	Transmissive mode, Normally black
Surface Treatment	Hard coating(3H), Anti-glare treatment of the front polarizer(Haze10%)

Product Specification

2. Absolute Maximum Ratings

The following items are maximum values which, if exceeded, may cause faulty operation or damage to the LCD module.

Table 1. ABSOLUTE MAXIMUM RATINGS

Parameter		Symbol	Value		Unit	Remark
			Min	Max		
Power Input Voltage	LCM	V _{LCD}	-0.3	+14.0	V _{DC}	at 25 ± 2 °C
	Backlight inverter	V _{BL}	-0.3	+27.0	V _{DC}	
ON/OFF Control Voltage		V _{ON/OFF}	-0.3	+5.5	V _{DC}	
Brightness Control Voltage		V _{BR}	0	+5.0	V _{DC}	
Operating Temperature		T _{OP}	0	+50	°C	Note 1,2
Storage Temperature		T _{ST}	-20	+60	°C	
Operating Ambient Humidity		H _{OP}	10	90	%RH	
Storage Humidity		H _{ST}	10	90	%RH	

Note : 1. Temperature and relative humidity range are shown in the figure below.
Wet bulb temperature should be Max 39 °C and no condensation of water.
2. Gravity mura can be guaranteed below 40°C condition.

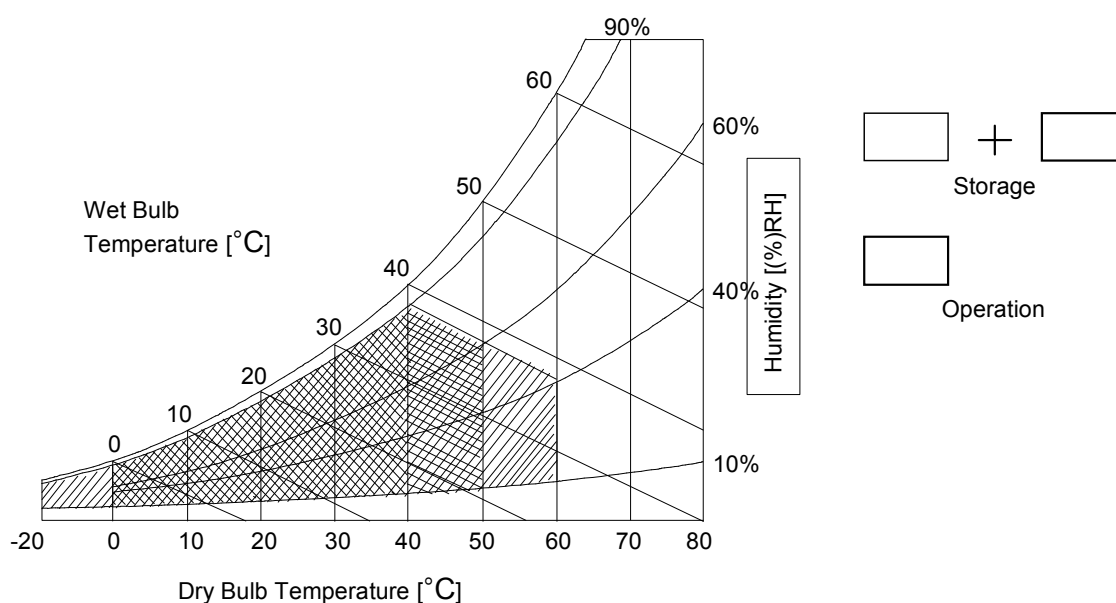

Product Specification

3. Electrical Specifications

3-1. Electrical Characteristics

It requires two power inputs. One is employed to power for the LCD circuit. The other is used for the CCFL backlight and inverter circuit.

Table 2. ELECTRICAL CHARACTERISTICS

Parameter	Symbol	Value			Unit	Note
		Min	Typ	Max		
Circuit :						
Power Input Voltage	V_{LCD}	10.8	12.0	13.2	V_{DC}	
Power Input Current	I_{LCD}	-	672	874	mA	1
		-	944	1227	mA	2
Power Consumption	P_{LCD}	-	8.06	10.5	Watt	1
Rush current	I_{RUSH}	-	-	5	A	3

- Notes : 1. The specified current and power consumption are under the $V_{LCD}=12.0V$, $25 \pm 2^{\circ}C$, $f_v=120Hz$ condition whereas mosaic pattern(8 x 6) is displayed and f_v is the frame frequency.
 2. The current is specified at the maximum current pattern.
 3. The duration of rush current is about 2ms and rising time of power input is **0.5ms** (min.).

White : 1023 Gray
 Black : 0 Gray

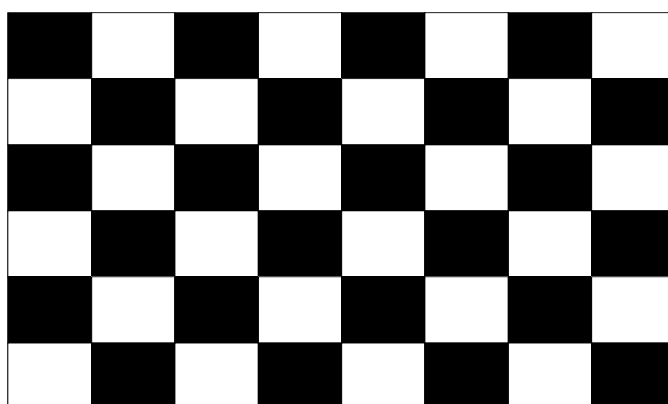

Mosaic Pattern(8 x 6)

Product Specification

Table 3. ELECTRICAL CHARACTERISTICS (Continue)

Parameter	Symbol	Values			Unit	Notes		
		Min	Typ	Max				
Inverter :								
Power Supply Input Voltage	VBL	22.8	24.0	25.2	Vdc	1		
Power Supply Input Current	After Aging	IBL_A	-	8.9	10	A	$V_{BR-A} = 1.65V \dots 1$	
			-	10	11	A	$V_{BR-A} = 3.3V \dots 1$	
	Before Aging	IBL_B	-	10	11	A	$V_{BR-A} = 1.65V \dots 2$	
			-	11	12	A	$V_{BR-A} = 3.3V \dots 2$	
Power Supply Input Current (In-Rush)	Irush	-	-	15	A	$V_{BL} = 22.8V$ $Ext V_{BR-B} = 100\%$ $V_{BR-A} = 1.65V$		
Power Consumption	PBL	-	213	240	W	$V_{BR-A} = 1.65V \dots 1$		
Input Voltage for Control System Signals	Brightness Adjust		V_{BR-A}	0.0	1.65	3.3	Vdc	
	On/Off	On	V on	2.5	-	5.0	Vdc	
		Off	V off	-0.3	0.0	0.8	Vdc	
	Brightness Adjust		$ExtV_{BR-B}$	30	-	100	%	On Duty
	PWM Frequency for NTSC & PAL		PAL	98	100	102	Hz	5
			NTSC	118	120	122	Hz	5
	Pulse Duty Level(PWM) (Burst mode)		High Level	2.5	-	5.0	Vdc	HIGH: Lamp on LOW:Lamp off
Low Level			0.0	-	0.8	Vdc		
Lamp:								
Discharge Stabilization Time	T_s			3	min	3		
Life Time		50,000			Hrs	4		

Notes :

- Electrical characteristics are determined after the unit has been 'ON' and stable for approximately 120 minutes at $25 \pm 2^\circ C$. The specified current and power consumption are under the typical supply Input voltage 24V and V_{BR} ($V_{BR-A} : 1.65V$ & $ExtV_{BR-B} : 100\%$), it is total power consumption.
- Electrical characteristics are determined within 30 minutes at $25 \pm 2^\circ C$.
The specified currents are under the typical supply Input voltage 24V.
- The brightness of the lamp after lighted for 5minutes is defined as 100%.
 T_s is the time required for the brightness of the center of the lamp to be not less than 95% at typical current.
The screen of LCD module may be partially dark by the time the brightness of lamp is stable after turn on.
- Specified Values are for a single lamp which is aligned horizontally.
The life time is determined as the time which luminance of the lamp is 50% compared to that of initial value at the typical lamp current ($V_{BR-A} : 1.65V$ & $ExtV_{BR-B} : 100\%$), on condition of continuous operating at $25 \pm 2^\circ C$
- LGD recommend that the PWM freq. is synchronized with One time harmonic of V_{sync} signal of system.
- The duration of rush current is about 10ms.

Product Specification

3-2. Interface Connections

This LCD module employs two kinds of interface connection, 51-pin and 41-pin connector are used for the module electronics and Master 14-pin and Slave 12-pin connectors are used for the integral backlight system.

3-2-1. LCD Module

- LCD Connector(CN1): FI-R51S-HF(manufactured by JAE) or compatible
Refer to below and next Page table
- Mating Connector : FI-R51HL(JAE) or compatible

Table 4-1. MODULE CONNECTOR(CN1) PIN CONFIGURATION

No	Symbol	Description	No	Symbol	Description
1	GND	Ground	27	Bit Select	'H' or NC= 10bit(D) , 'L' = 8bit
2	NC	No Connection	28	R2AN	SECOND LVDS Receiver Signal (A-)
3	NC	No Connection	29	R2AP	SECOND LVDS Receiver Signal (A+)
4	NC	No Connection	30	R2BN	SECOND LVDS Receiver Signal (B-)
5	NC	No Connection	31	R2BP	SECOND LVDS Receiver Signal (B+)
6	NC	No Connection	32	R2CN	SECOND LVDS Receiver Signal (C-)
7	LVDS Select	'H' =JEIDA , 'L' or NC = VESA	33	R2CP	SECOND LVDS Receiver Signal (C+)
8	VBR EXT	External VBR (From System)	34	GND	Ground
9	OPC OUT	OPC output (From LCM)	35	R2CLKN	SECOND LVDS Receiver Clock Signal(-)
10	OPC Enable	'H' = Enable , 'L' or NC = Disable	36	R2CLKP	SECOND LVDS Receiver Clock Signal(+)
11	GND	Ground	37	GND	Ground
12	R1AN	FIRST LVDS Receiver Signal (A-)	38	R2DN	SECOND LVDS Receiver Signal (D-)
13	R1AP	FIRST LVDS Receiver Signal (A+)	39	R2DP	SECOND LVDS Receiver Signal (D+)
14	R1BN	FIRST LVDS Receiver Signal (B-)	40	R2EN	SECOND LVDS Receiver Signal (E-)
15	R1BP	FIRST LVDS Receiver Signal (B+)	41	R2EP	SECOND LVDS Receiver Signal (E+)
16	R1CN	FIRST LVDS Receiver Signal (C-)	42	Reserved	No connection or GND
17	R1CP	FIRST LVDS Receiver Signal (C+)	43	Reserved	No connection or GND
18	GND	Ground	44	GND	Ground
19	R1CLKN	FIRST LVDS Receiver Clock Signal(-)	45	GND	Ground
20	R1CLKP	FIRST LVDS Receiver Clock Signal(+)	46	GND	Ground
21	GND	Ground	47	NC	No connection
22	R1DN	FIRST LVDS Receiver Signal (D-)	48	VLCD	Power Supply +12.0V
23	R1DP	FIRST LVDS Receiver Signal (D+)	49	VLCD	Power Supply +12.0V
24	R1EN	FIRST LVDS Receiver Signal (E-)	50	VLCD	Power Supply +12.0V
25	R1EP	FIRST LVDS Receiver Signal (E+)	51	VLCD	Power Supply +12.0V
26	Reserved	No connection or GND	-	-	-

- Notes :
1. All GND(ground) pins should be connected together to the LCD module's metal frame.
 2. All V_{LCD} (power input) pins should be connected together.
 3. All Input levels of LVDS signals are based on the EIA 644 Standard. (Please see the Appendix X)
 4. Specific pins(pin No. #2~#6) are used for internal data process of the LCD module.
If not used, these pins are no connection.
 5. Specific pins(pin No. #8~#10) are used for OPC function of the LCD module.
If not used, these pins are no connection. (Please see the Appendix V for more information.)
 6. LVDS pin (pin No. #24,25,40,41) are used for 10Bit(D) of the LCD module.
If used for 8Bit(R), these pins are no connection.
 7. Specific pin No. #44 is used for "No signal detection" of system signal interface.
It should be GND for NSB(No Signal Black) during the system interface signal is not.
If this pin is "H", LCD Module displays AGP(Auto Generation Pattern).

Product Specification

- LCD Connector(CN2): FI-RE41S-HF, Refer to below table
- Mating Connector : FI-RE41HL

Table 4-2. MODULE CONNECTOR(CN2) PIN CONFIGURATION

No	Symbol	Description	No	Symbol	Description
1	NC	No connection(Reserved)	22	R3EN	THIRD LVDS Receiver Signal (E-)
2	NC	No connection	23	R3EP	THIRD LVDS Receiver Signal (E+)
3	NC	No connection	24	GND	Ground
4	NC	No connection	25	GND	Ground
5	NC	No connection	26	R4AN	FORTH LVDS Receiver Signal (A-)
6	NC	No connection	27	R4AP	FORTH LVDS Receiver Signal (A+)
7	NC	No connection	28	R4BN	FORTH LVDS Receiver Signal (B-)
8	NC	No connection	29	R4BP	FORTH LVDS Receiver Signal (B+)
9	GND	Ground	30	R4CN	FORTH LVDS Receiver Signal (C-)
10	R3AN	THIRD LVDS Receiver Signal (A-)	31	R4CP	FORTH LVDS Receiver Signal (C+)
11	R3AP	THIRD LVDS Receiver Signal (A+)	32	GND	Ground
12	R3BN	THIRD LVDS Receiver Signal (B-)	33	R4CLKN	FORTH LVDS Receiver Clock Signal(-)
13	R3BP	THIRD LVDS Receiver Signal (B+)	34	R4CLKP	FORTH LVDS Receiver Clock Signal(+)
14	R3CN	THIRD LVDS Receiver Signal (C-)	35	GND	Ground
15	R3CP	THIRD LVDS Receiver Signal (C+)	36	R4DN	FORTH LVDS Receiver Signal (D-)
16	GND	Ground	37	R4DP	FORTH LVDS Receiver Signal (D+)
17	R3CLKN	THIRD LVDS Receiver Clock Signal(-)	38	R4EN	FORTH LVDS Receiver Signal (E-)
18	R3CLKP	THIRD LVDS Receiver Clock Signal(+)	39	R4EP	FORTH LVDS Receiver Signal (E+)
19	GND	Ground	40	GND	Ground
20	R3DN	THIRD LVDS Receiver Signal (D-)	41	GND	Ground
21	R3DP	THIRD LVDS Receiver Signal (D+)	-		

- Notes : 1. All GND(ground) pins should be connected together to the LCD module's metal frame.
 2. LVDS pin (pin No. #22,23,38,39) are used for 10Bit(D) of the LCD module.
 If used for 8Bit(R), these pins are no connection.

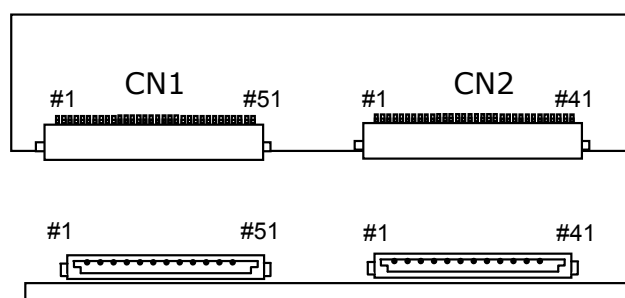
**Rear view of LCM**

[CN1]

- Part/No. : FI-RE51S-HF(JAE)
- Mating connector : FI-RE51HL
(Manufactured by JAE)

[CN2]

- Part/No. : FI-RE41S-HF(JAE)
- Mating connector : FI-RE41HL
(Manufactured by JAE)

Product Specification

3-2-2. Backlight Inverter

Master

-Inverter Connector : 20022WR-14B1(Yeonho)
or Equivalent

- Mating Connector : 20022HS-14 or Equivalent

Slave

-Inverter Connector : 20022WR-12B1(Yeonho)
or Equivalent

-Mating Connector : 20022HS-12 or Equivalent

Table 5. INVERTER CONNECTOR PIN CONFIGURATION

Pin No	Symbol	Description	Master	Slave	Note
1	VBL	Power Supply +24.0V	VBL	VBL	
2	VBL	Power Supply +24.0V	VBL	VBL	
3	VBL	Power Supply +24.0V	VBL	VBL	
4	VBL	Power Supply +24.0V	VBL	VBL	
5	VBL	Power Supply +24.0V	VBL	VBL	
6	GND	Backlight Ground	GND	GND	1
7	GND	Backlight Ground	GND	GND	
8	GND	Backlight Ground	GND	GND	
9	GND	Backlight Ground	GND	GND	
10	GND	Backlight Ground	GND	GND	
11	VBR-A	Analog Dimming	VBR-A	Don't care	2
12	VON/OFF	Backlight ON/OFF control	VON/OFF	Don't care	
13	EXTVBR-B	External PWM	EXTVBR-B	-	
14	Status	Lamp Status	Status	-	3

Notes : 1. GND should be connected to the LCD module's metal frame.

2. Minimum Brightness : 0.0V / Maximum Brightness : 3.3V / "OPEN" : 1.65V

3. Normal : Low (under 0.7V) / Abnormal : High (upper 3.0V)

Please see Appendix VI for more information.

4. Each impedance of pin #11, and 13 is 190[KΩ] and 50[KΩ].

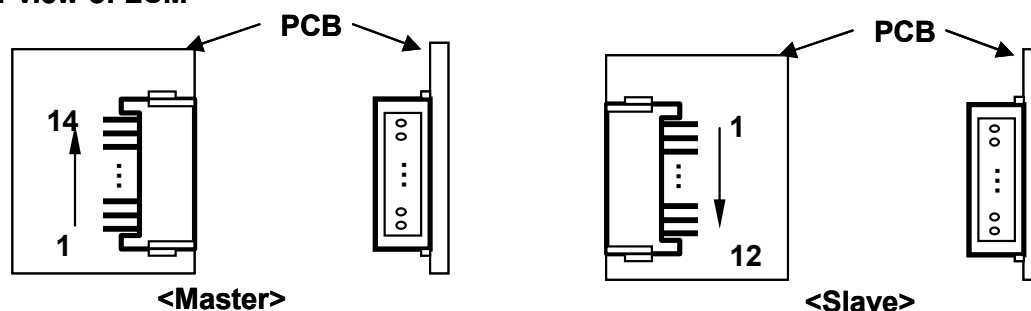
◆ Rear view of LCM

Product Specification

3-3. Signal Timing Specifications

Table 6 shows the signal timing required at the input of the LVDS transmitter. All of the interface signal timing should be satisfied with the following specification for normal operation.

Table 6. TIMING TABLE for NTSC/ATSC (DE Only Mode)

ITEM		Symbol	Min	Typ	Max	Unit	Note
Horizontal	Display Period	t_{HV}	480	480	480	t_{CLK}	1920/4
	Blank	t_{HB}	40	70	200	t_{CLK}	1
	Total	t_{HP}	520	550	680	t_{CLK}	
Vertical	Display Period	t_{VV}	1080	1080	1080	Lines	
	Blank	t_{VB}	10	45	86	Lines	1
	Total	t_{VP}	1090	1125	1166	Lines	

ITEM		Symbol	Min	Typ	Max	Unit	Note
Frequency	DCLK	f_{CLK}	66.97	74.25	75.00	MHz	
	Horizontal	f_H	121.8	135	140	KHz	2
	Vertical	f_V	108.2	120	123.6	Hz	2

- Notes :
1. The Input of HSYNC & VSYNC signal does not have an effect on normal operation(DE Only Mode). If you use spread spectrum for EMI, add some additional clock to minimum value for clock margin.
 2. The performance of the electro-optical characteristics may be influenced by variance of the vertical refresh rate and the horizontal frequency.

Product Specification

Table 7 shows the signal timing required at the input of the LVDS transmitter. All of the interface signal timing should be satisfied with the following specification for normal operation.

Table7. TIMING TABLE for DVB/PAL (DE Only Mode)

ITEM		Symbol	Min	Typ	Max	Unit	Note
Horizontal	Display Period	t_{HV}	480	480	480	t_{CLK}	1920/4
	Blank	t_{HB}	40	70	200	t_{CLK}	1
	Total	t_{HP}	520	550	680	t_{CLK}	
Vertical	Display Period	t_{VV}	1080	1080	1080	Lines	
	Blank	t_{VB}	228	270	300	Lines	1
	Total	t_{VP}	1308	1350	1380	Lines	

ITEM		Symbol	Min	Typ	Max	Unit	Note
Frequency	DCLK	f_{CLK}	66.97	74.25	75.00	MHz	
	Horizontal	f_H	121.8	135	140	KHz	2
	Vertical	f_V	95	100	103.7	Hz	2

- Notes :
1. The Input of HSYNC & VSYNC signal does not have an effect on normal operation(DE Only Mode). If you use spread spectrum for EMI, add some additional clock to minimum value for clock margin.
 2. The performance of the electro-optical characteristics may be influenced by variance of the vertical refresh rate and the horizontal frequency.

Product Specification

3-4. Signal Timing Waveforms

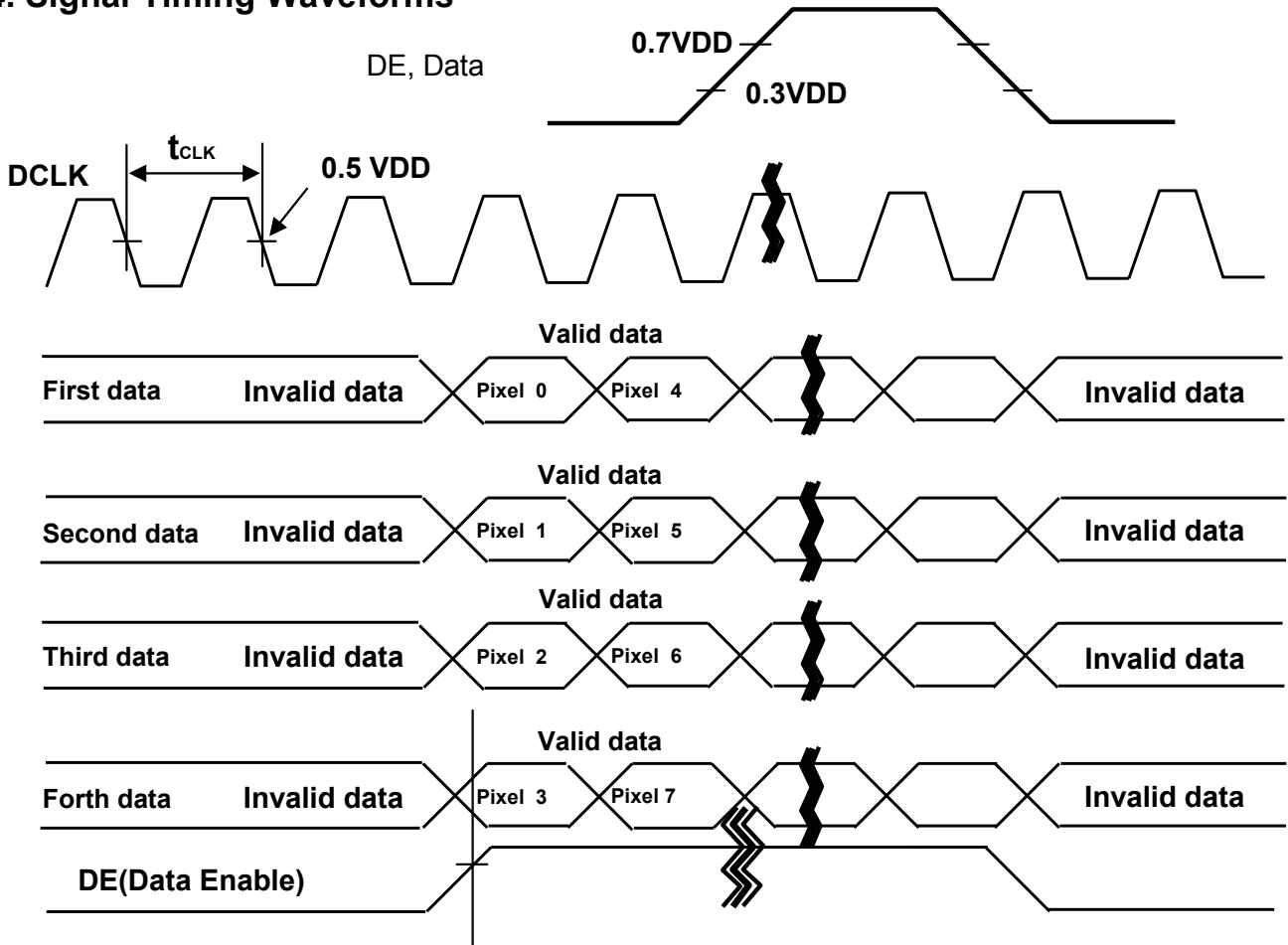

* Reference : Sync. Relation

* $t_{HB} = t_{HFP} + t_{WH} + t_{HBP}$

* $t_{VB} = t_{VFP} + t_{VW} + t_{VBP}$

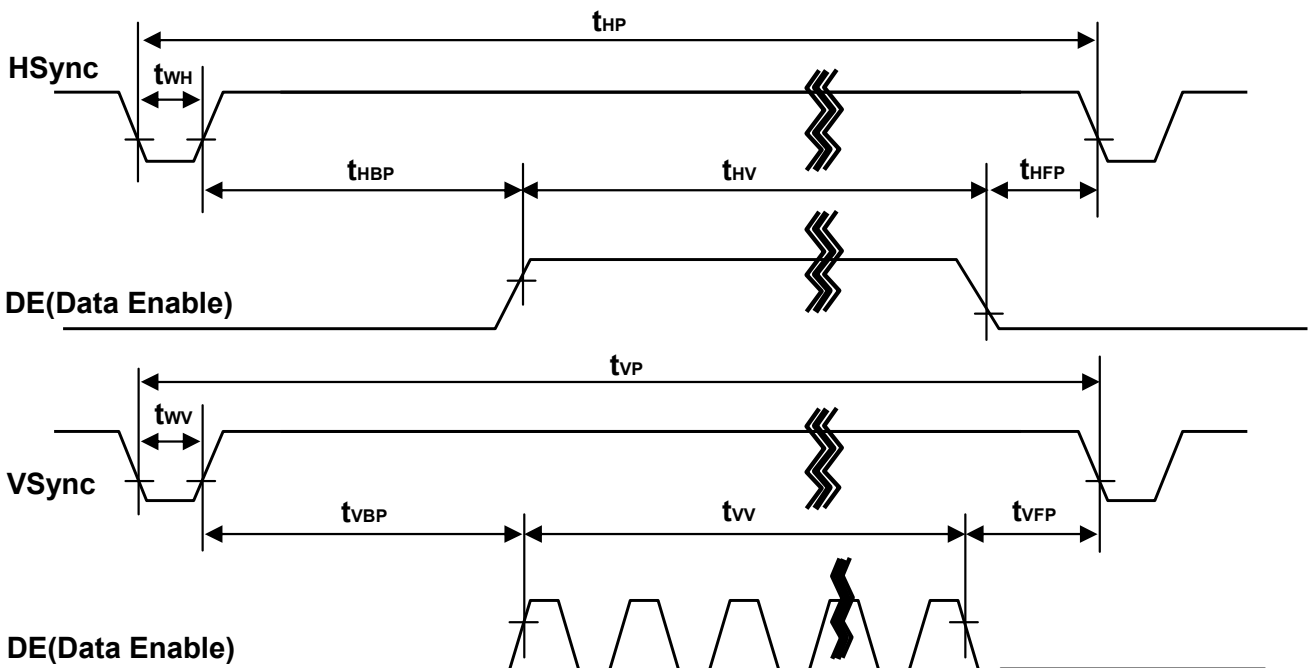

Product Specification

3-5. Color Data Reference

The brightness of each primary color(red,green,blue) is based on the 10-bit gray scale data input for the color. The higher binary input, the brighter the color. Table 8 provides a reference for color versus data input.

Table 8. COLOR DATA REFERENCE

Color		Input Color Data																													
		RED										GREEN										BLUE									
		MSB	LSB								MSB	LSB								MSB	LSB										
		R9	R8	R7	R6	R5	R4	R3	R2	R1	R0	G9	G8	G7	G6	G5	G4	G3	G2	G1	G0	B9	B8	B7	B6	B5	B4	B3	B2	B1	B0
Basic Color	Black	0	0	0	0	0	0	0	0	0	0	0	0	0	0	0	0	0	0	0	0	0	0	0	0	0	0	0	0	0	0
	Red (1023)	1	1	1	1	1	1	1	1	1	1	0	0	0	0	0	0	0	0	0	0	0	0	0	0	0	0	0	0	0	0
	Green (1023)	0	0	0	0	0	0	0	0	0	0	1	1	1	1	1	1	1	1	1	1	0	0	0	0	0	0	0	0	0	0
	Blue (1023)	0	0	0	0	0	0	0	0	0	0	0	0	0	0	0	0	0	0	0	0	1	1	1	1	1	1	1	1	1	1
	Cyan	0	0	0	0	0	0	0	0	0	0	1	1	1	1	1	1	1	1	1	1	1	1	1	1	1	1	1	1	1	1
	Magenta	1	1	1	1	1	1	1	1	1	1	0	0	0	0	0	0	0	0	0	0	1	1	1	1	1	1	1	1	1	1
	Yellow	1	1	1	1	1	1	1	1	1	1	1	1	1	1	1	1	1	1	1	1	0	0	0	0	0	0	0	0	0	0
	White	1	1	1	1	1	1	1	1	1	1	1	1	1	1	1	1	1	1	1	1	1	1	1	1	1	1	1	1	1	1
RED	RED (000)	0	0	0	0	0	0	0	0	0	0	0	0	0	0	0	0	0	0	0	0	0	0	0	0	0	0	0	0	0	
	RED (001)	0	0	0	0	0	0	0	0	0	1	0	0	0	0	0	0	0	0	0	0	0	0	0	0	0	0	0	0	0	0
									
	RED (1022)	1	1	1	1	1	1	1	1	1	0	0	0	0	0	0	0	0	0	0	0	0	0	0	0	0	0	0	0	0	0
	RED (1023)	1	1	1	1	1	1	1	1	1	1	0	0	0	0	0	0	0	0	0	0	0	0	0	0	0	0	0	0	0	0
GREEN	GREEN (000)	0	0	0	0	0	0	0	0	0	0	0	0	0	0	0	0	0	0	0	0	0	0	0	0	0	0	0	0	0	
	GREEN (001)	0	0	0	0	0	0	0	0	0	1	0	0	0	0	0	0	0	0	0	0	0	0	0	0	0	0	0	0	0	0
									
	GREEN (1022)	0	0	0	0	0	0	0	0	0	0	1	1	1	1	1	1	1	1	1	0	0	0	0	0	0	0	0	0	0	0
	GREEN (1023)	0	0	0	0	0	0	0	0	0	0	1	1	1	1	1	1	1	1	1	1	0	0	0	0	0	0	0	0	0	0
BLUE	BLUE (000)	0	0	0	0	0	0	0	0	0	0	0	0	0	0	0	0	0	0	0	0	0	0	0	0	0	0	0	0	0	
	BLUE (001)	0	0	0	0	0	0	0	0	0	1	0	0	0	0	0	0	0	0	0	0	0	0	0	0	0	0	0	0	0	1
									
	BLUE (1022)	0	0	0	0	0	0	0	0	0	0	0	0	0	0	0	0	0	0	0	0	1	1	1	1	1	1	1	1	1	0
	BLUE (1023)	0	0	0	0	0	0	0	0	0	0	0	0	0	0	0	0	0	0	0	0	1	1	1	1	1	1	1	1	1	1

Product Specification

3-6. Power Sequence

3-6-1. LCD Driving circuit

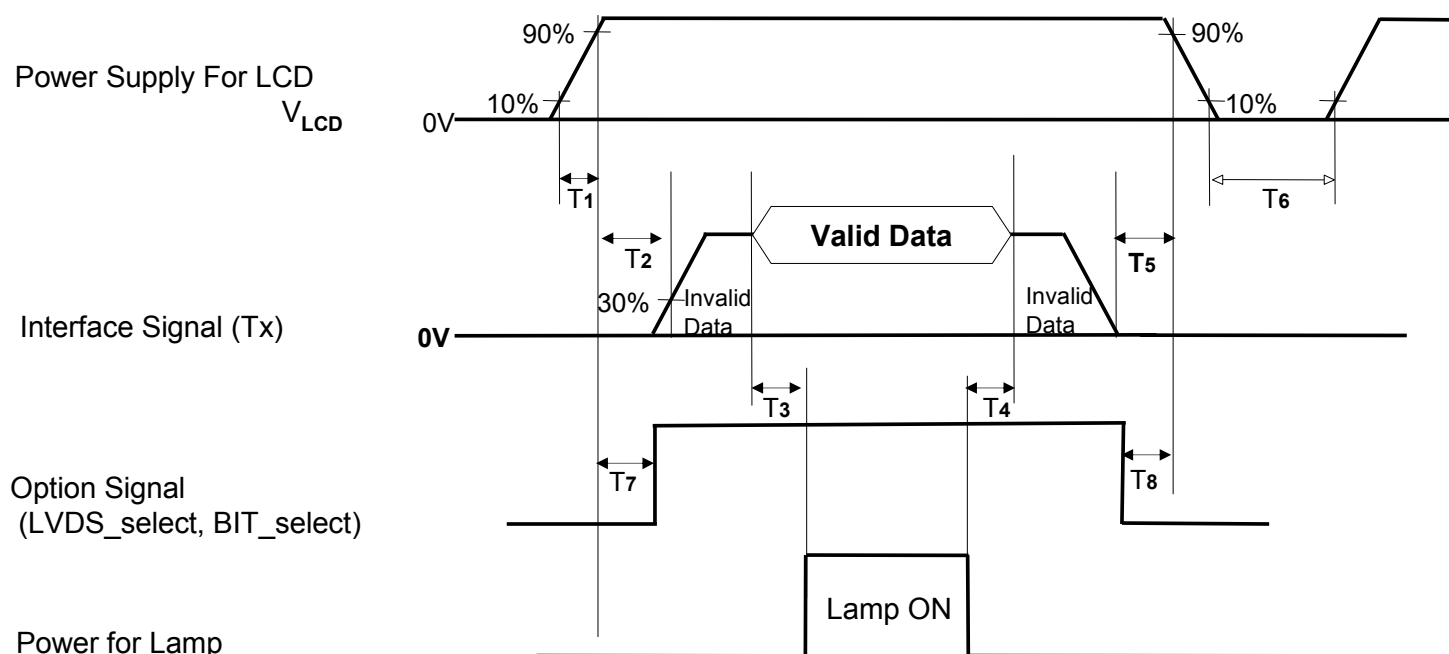

Table 9. POWER SEQUENCE

Parameter	Value			Unit	Notes
	Min	Typ	Max		
T1	0.5	-	20	ms	
T2	0.5	-	-	ms	4
T3	200	-	-	ms	3
T4	200	-	-	ms	3
T5	0	-	-	ms	
T6	2.0	-	-	s	5
T7	0.5	-	T2	ms	4
T8	0	-	-	ms	4

- Note :
1. Please avoid floating state of interface signal at invalid period.
 2. When the interface signal is invalid, be sure to pull down the power supply V_{LCD} to 0V.
 3. The T3/T4 is recommended value, the case when failed to meet a minimum specification, abnormal display would be shown. There is no reliability problem.
 4. If the on time of signals (Interface signal and Option signals) precedes the on time of Power (V_{LCD}), it will be happened abnormal display.
 5. T6 should be measured after the Module has been fully discharged between power off and on period.

Product Specification

3-6-2. Sequence for Inverter

Power Supply For Inverter

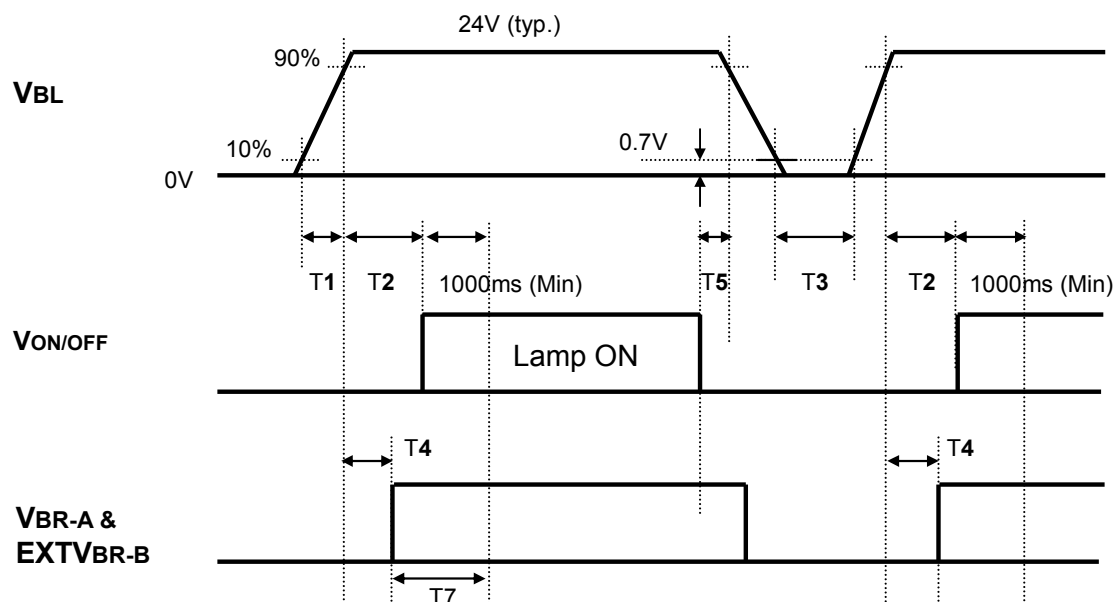

3-6-3. Dip condition for Inverter

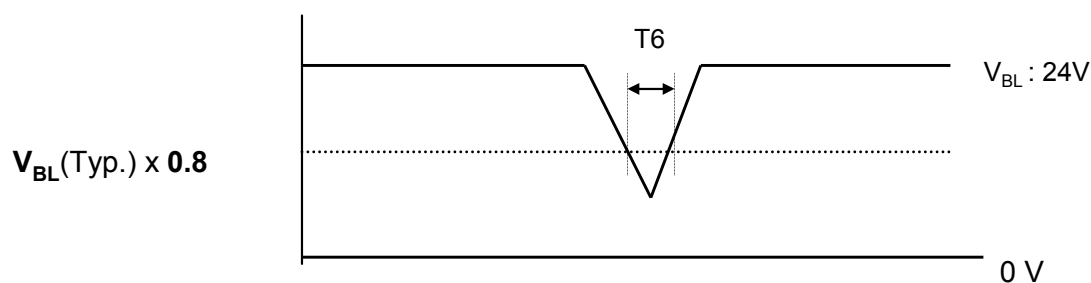

Table 10. Power Sequence for Inverter

Parameter	Values			Units	Remarks
	Min	Typ	Max		
T1	20	-	-	ms	1
T2	500	-	-	ms	
T3	200	-	-	ms	
T4	0	-	-	ms	2
T5	10	-	-	ms	
T6	-	-	10	ms	$V_{BL}(Typ) \times 0.8$
T7	1000	-	-	ms	3

- Notes : 1. T1 describes rising time of 0V to 24V and this parameter does not applied at restarting time.
 2. T4(max) is less than T2.
 3. In T7 section, EXT V_{BR-B} is recommended 100%.

Product Specification

4. Optical Specification

Optical characteristics are determined after the unit has been 'ON' and stable in a dark environment at $25 \pm 2^\circ\text{C}$. The values specified are at an approximate distance 50cm from the LCD surface at a viewing angle of Φ and θ equal to 0° .

FIG. 1 shows additional information concerning the measurement equipment and method.

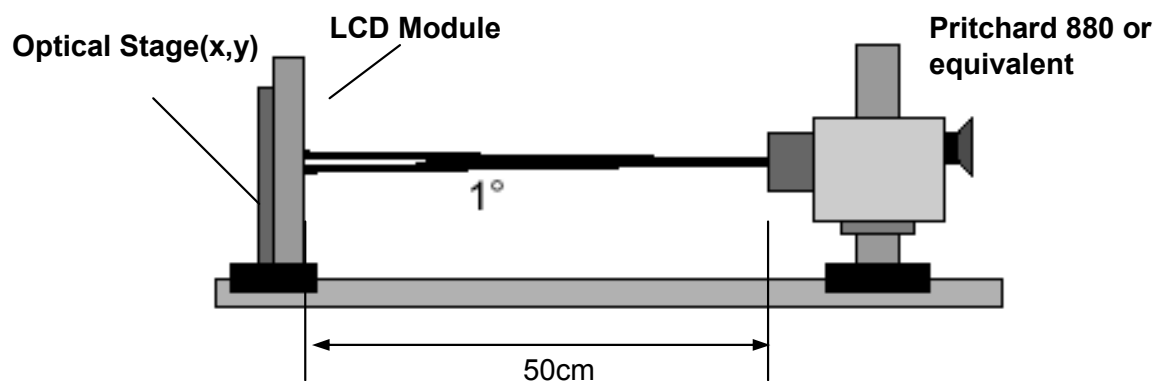

FIG. 1 Optical Characteristic Measurement Equipment and Method

Table 11. OPTICAL CHARACTERISTICS

$T_a = 25 \pm 2^\circ\text{C}$, $V_{\text{LCD}} = 12.0\text{V}$, $f_v = 120\text{Hz}$, $D_{\text{clk}} = 74.25\text{MHz}$
 $V_{\text{BR_A}} = 1.65\text{V}$, $\text{EXTVBR_B} = 100\%$

Parameter	Symbol	Value			Unit	Note	
		Min	Typ	Max			
Contrast Ratio	CR	1000	1400	-		1	
Surface Luminance, white	L_{WH}	400	500		cd/m ²	2	
Luminance Variation	δ_{WHITE} 5P			1.3		3	
Response Time	G to G	-	5	8	ms	4	
	MPRT	-	8	12	ms	5	
	Uniformity	δ_{MPRT}	-	-	1		6
	Uniformity	$\delta_{\text{G TO G}}$	-	-	1		6
Color Coordinates [CIE1931]	RED	Rx	Typ -0.03	0.636	Typ +0.03		
		Ry		0.334			
	GREEN	Gx		0.290			
		Gy		0.608			
	BLUE	Bx		0.145			
		By		0.064			
	WHITE	Wx		0.279			
		Wy		0.292			
Viewing Angle (CR>10)							
	x axis, right($\phi=0^\circ$)	θ_r	89	-	-	degree	7
	x axis, left ($\phi=180^\circ$)	θ_l	89	-	-		
	y axis, up ($\phi=90^\circ$)	θ_u	89	-	-		
	y axis, down ($\phi=270^\circ$)	θ_d	89	-	-		
Gray Scale			2.2			8	

Product Specification

Notes :1. Contrast Ratio(CR) is defined mathematically as :

CR(Contrast Ratio) = Maximum CR_n (n=1, 2, 3, 4, 5)

Surface Luminance at position n with all white pixels

$$CR_n = \frac{\text{Surface Luminance at position n with all white pixels}}{\text{Surface Luminance at position n with all black pixels}}$$

Surface Luminance at position n with all black pixels

n = the Position number(1, 2, 3, 4, 5). For more information, see FIG 2.

2. Surface luminance is determined after the unit has been 'ON' and 1Hour after lighting the backlight in a dark environment at 25±2°C. Surface luminance is the luminance value at center 1-point across the LCD surface 50cm from the surface with all pixels displaying white. For more information see the FIG. 2.
3. The variation in surface luminance, δ WHITE is defined as :

$$\delta \text{ WHITE}(5P) = \frac{\text{Maximum}(L_{on1}, L_{on2}, L_{on3}, L_{on4}, L_{on5})}{\text{Minimum}(L_{on1}, L_{on2}, L_{on3}, L_{on4}, L_{on5})}$$
 Where L_{on1} to L_{on5} are the luminance with all pixels displaying white at 5 locations .
For more information, see the FIG. 2.
4. Response time is the time required for the display to transit from G(N) to G(M) (Rise Time, Tr_R) and from G(M) to G(N) (Decay Time, Tr_D). For additional information see the FIG. 3. (N<M)
* G to G Spec stands for average value of all measured points.
Photo Detector : RD-80S / Field : 2 °
5. MPRT is defined as the 10% to 90% blur-edge width Bij(pixels) and scroll speed U(pixels/frame)at the moving picture. For more information, see FIG 4
6. Gray to Gray Response time uniformity is Reference data. Please see Appendix XII.
7. Viewing angle is the angle at which the contrast ratio is greater than 10. The angles are determined for the horizontal or x axis and the vertical or y axis with respect to the z axis which is normal to the LCD module surface. For more information, see the FIG. 5.
8. Gray scale specification
Gamma Value is approximately 2.2. For more information, see the Table 12.

Table 12. GRAY SCALE SPECIFICATION

Gray Level	Luminance [%] (Typ.)
L0	0.07
L63	0.27
L127	1.04
L191	2.49
L255	4.68
L319	7.66
L383	11.5
L447	16.1
L511	21.6
L575	28.1
L639	35.4
L703	43.7
L767	53.0
L831	63.2
L895	74.5
L959	86.7
L1023	100

Product Specification

Measuring point for surface luminance & measuring point for luminance variation.

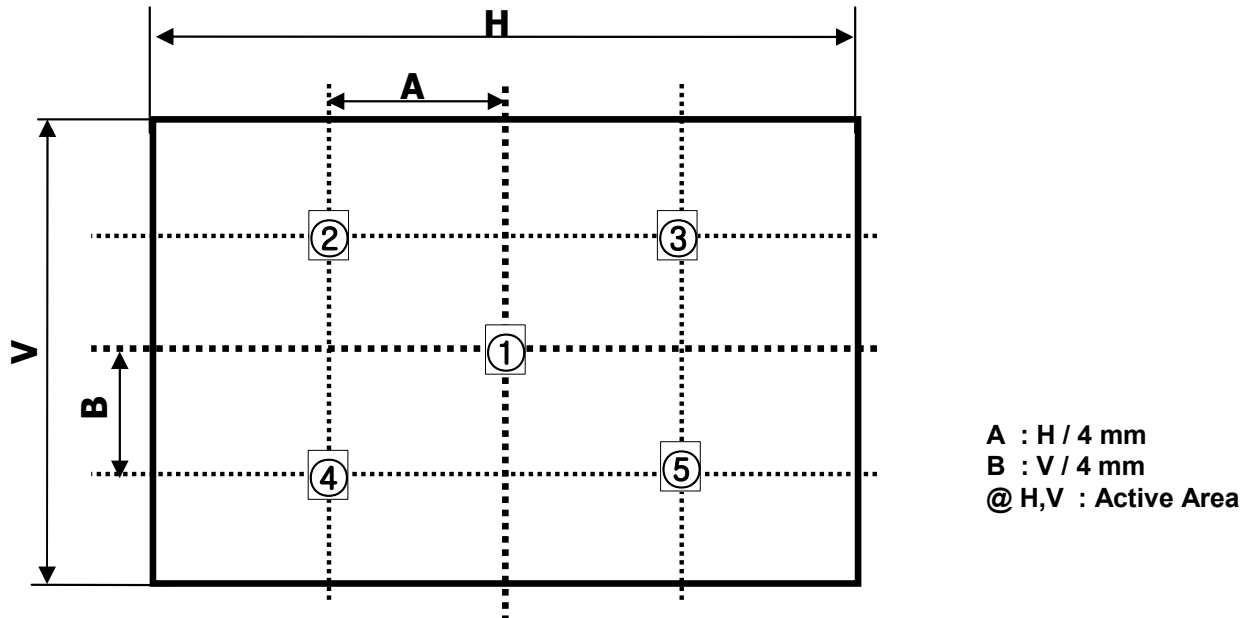

FIG. 2 5 Points for Luminance Measure

Response time is defined as the following figure and shall be measured by switching the input signal for “Gray(N)” and “Gray(M)”.

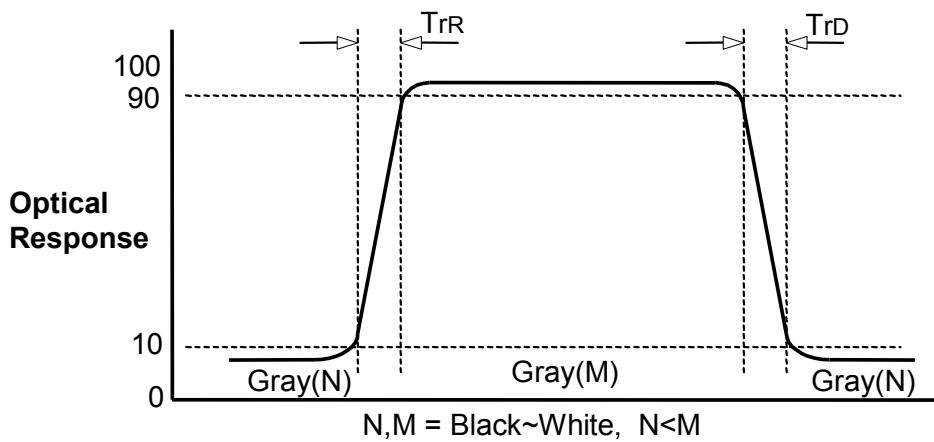
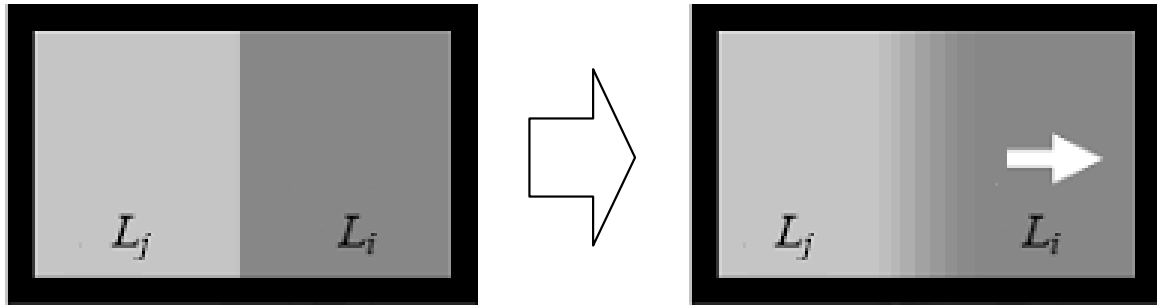

FIG. 3 Response Time

Product Specification

MPRT is defined as the 10% to 90% blur-edge with B_{ij} (pixels) and scroll speed U (pixels/frame)at the moving picture.



$$M = \frac{1}{U} B_{ij} \quad (i \neq j)$$

Example) $B_{ij} = 12\text{pixels}$, $U = 10\text{pixels} / 120\text{Hz}$
 $M = 12\text{pixels} / (10\text{pixels} / 120\text{Hz})$
 $= 12\text{pixels} / \{10\text{pixels} / (1/120)\text{s}\}$
 $= 12 / 1,200 \text{ s}$
 $= 10 \text{ ms}$

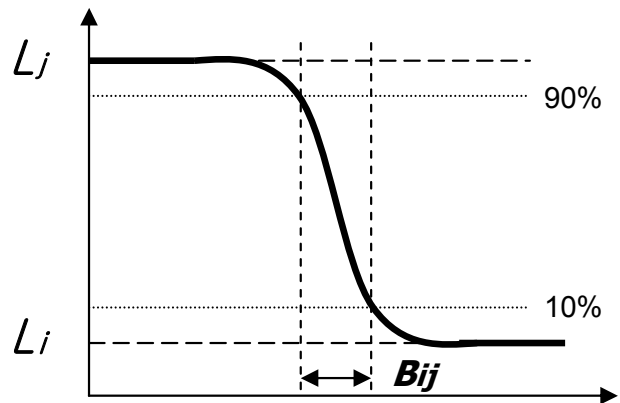

FIG. 4 MPRT

Dimension of viewing angle range

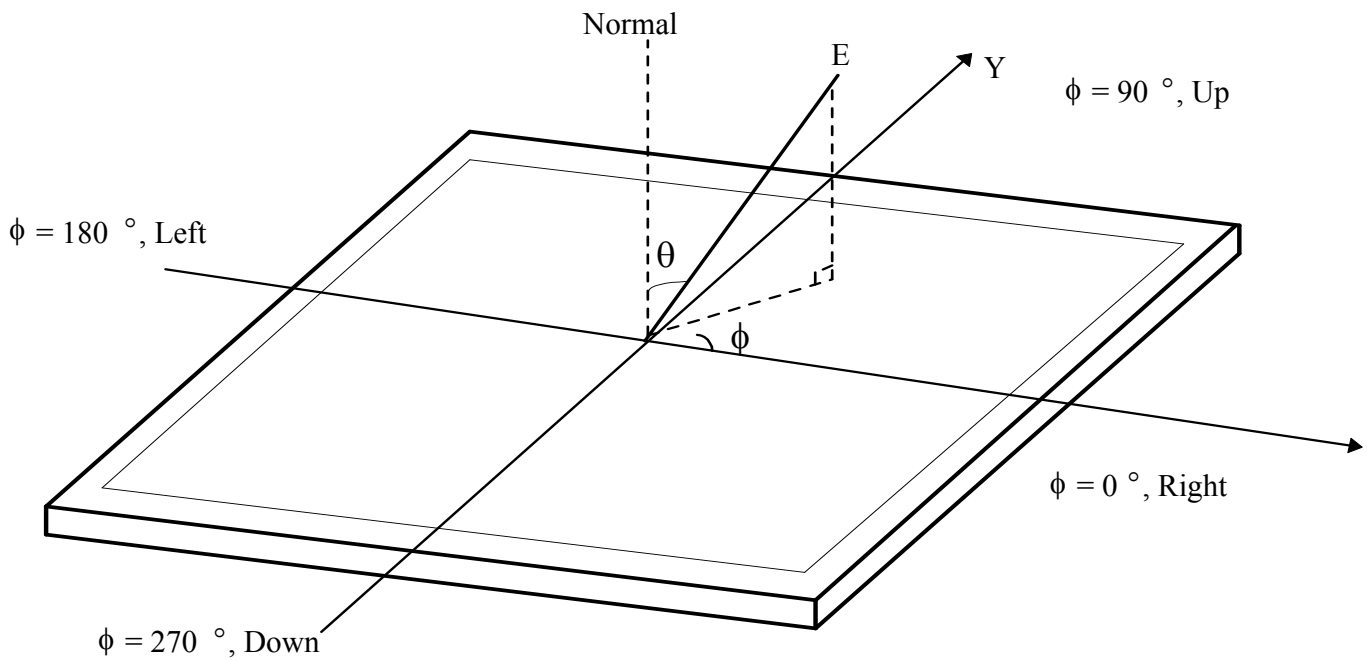

FIG. 5 Viewing angle

Product Specification

5. Mechanical Characteristics

Table 13 provides general mechanical characteristics.

Table 13. MECHANICAL CHARACTERISTICS

Item	Value	
Outline Dimension	Horizontal	1075.6 mm
	Vertical	620.8 mm
	Depth	33.8 mm
Bezel Area	Horizontal	1047.6 mm
	Vertical	592.8 mm
Active Display Area	Horizontal	1039.68 mm
	Vertical	584.82 mm
Weight	14.5 Kg (Typ.), 15.0 kg (Max.)	

Note : Please refer to a mechanical drawing in terms of tolerance at the next page.

Product Specification

<FRONT VIEW>

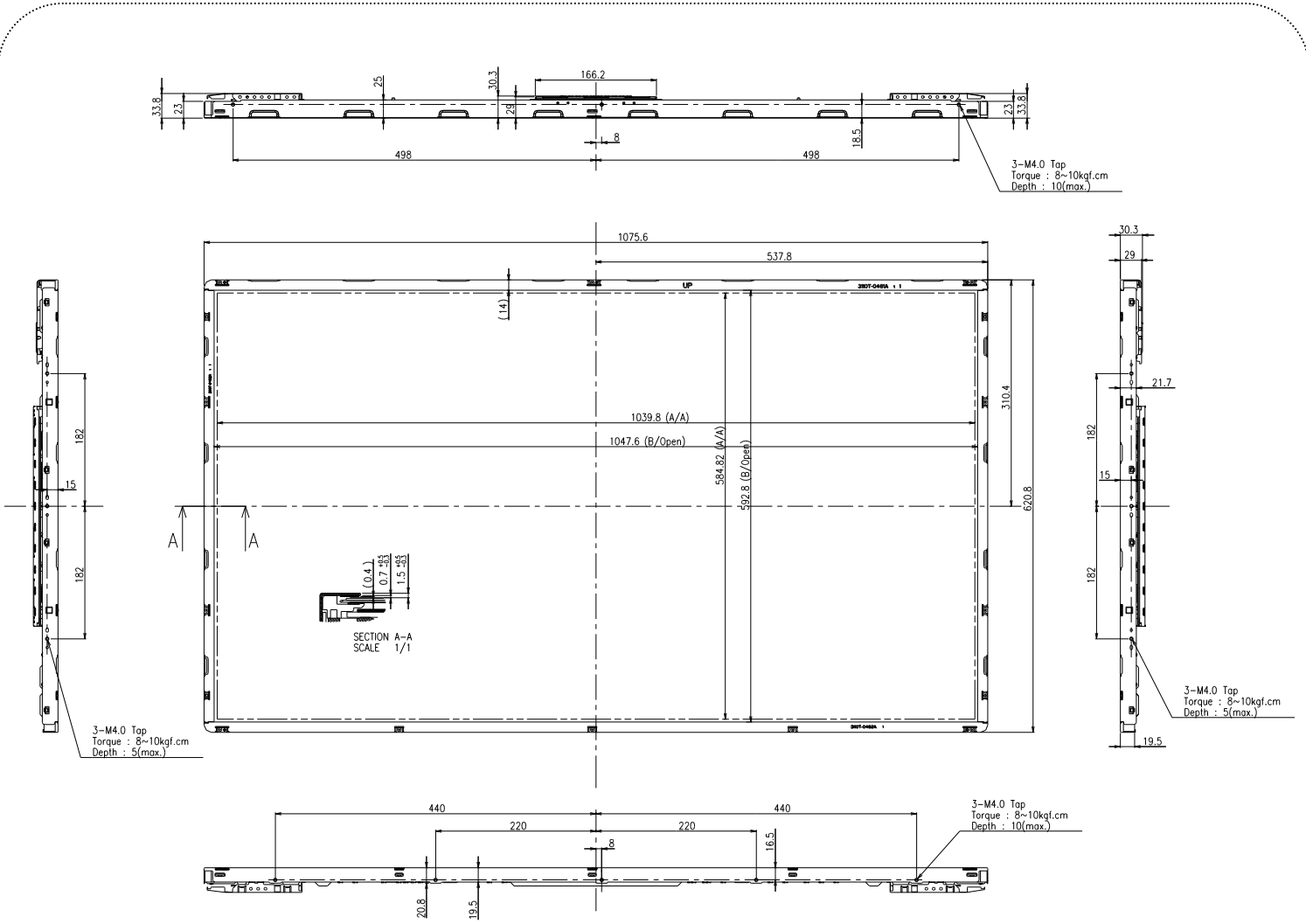

- NOTES
1. Unspecified tolerances are to be $\pm 1.0\text{mm}$.
 2. Tilt and partial disposition tolerance of display area are as following.
 - (1) X-Direction : IA-BI $\leq 1.5\text{mm}$
 - (2) Y-Direction : IC-DI $\leq 1.5\text{mm}$

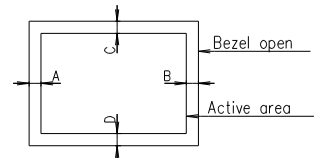

Product Specification

<REAR VIEW>

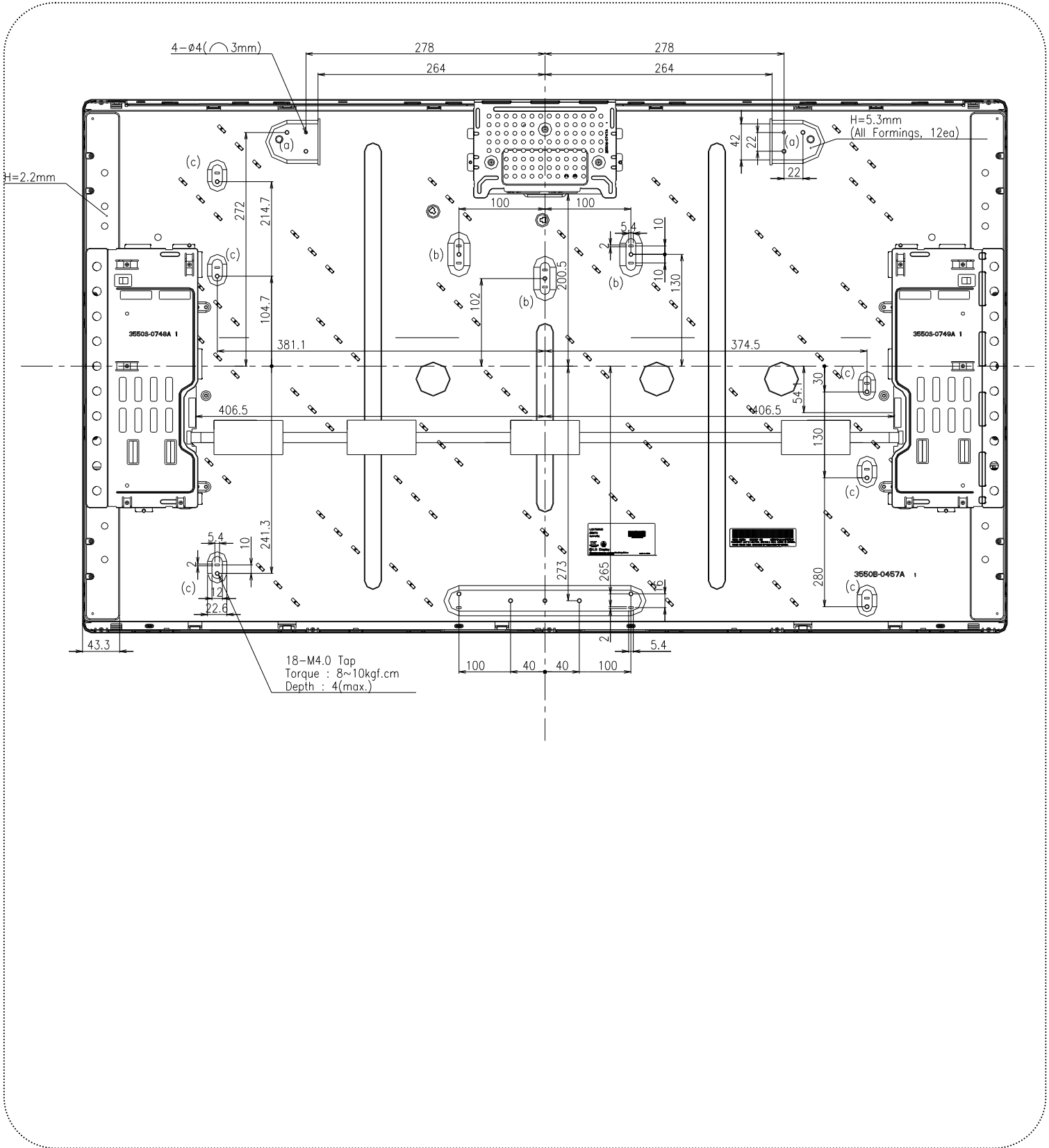

Product Specification

6. Reliability**Table 14. ENVIRONMENT TEST CONDITION**

No.	Test Item	Condition
1	High temperature storage test	Ta= 60°C 240h
2	Low temperature storage test	Ta= -20°C 240h
3	High temperature operation test	Ta= 50°C 50%RH 240h
4	Low temperature operation test	Ta= 0°C 240h
5	Vibration test (non-operating)	Wave form : random Vibration level : 1.0G RMS Bandwidth : 10-300Hz Duration : X,Y,Z Each direction per 10 min.
6	Shock test (non-operating)	Shock level :50G(X,Y axis) , 35G(Z axis) Waveform : half sine wave, 11ms Direction : ±X, ±Y, ±Z One time each direction
8	Humidity condition Operation	Ta= 40 °C, 90%RH
9	Altitude operating storage / shipment	0 - 15,000 feet 0 - 40,000 feet

Note : Before and after Reliability test, LCM should be operated with normal function

7. International Standards

7-1. Safety

- a) UL 60065, 7th Edition, dated June 30, 2003, Underwriters Laboratories, Inc., Standard for Audio, Video and Similar Electronic Apparatus.
- b) CAN/CSA C22.2, No. 60065:03, Canadian Standards Association, Standard for Audio, Video and Similar Electronic Apparatus.
- c) IEC60065:2001, 7th Edition CB-scheme and EN 60065:2002, Safety requirements for Audio, Video and Similar Electronic Apparatus..

7-2. EMC

- a) ANSI C63.4 "Methods of Measurement of Radio-Noise Emissions from Low-Voltage Electrical and Electrical Equipment in the Range of 9kHz to 40GHz. "American National Standards Institute(ANSI), 1992
- b) CISPR13 "Limits and Methods of Measurement of Radio interference characteristics of Sound and Television broadcast receivers and associated equipment"
CISPR22 "Limits and Methods of Measurement of Radio interference characteristics of Information Technology Equipment" International Special Committee on Radio Interference.
- c) EN55013 "Limits and Methods of Measurement of Radio interference characteristics of Sound and Television broadcast receivers and associated equipment"
EN55022 "Limits and Methods of Measurement of Radio interference characteristics of Information Technology Equipment" European Committee for Electro Technical Standardization.(CENELEC), 1988(Including A1:2000)

Product Specification

8. Packing

8-1. Information of LCM Label

a) Lot Mark

A	B	C	D	E	F	G	H	I	J	K	L	M
---	---	---	---	---	---	---	---	---	---	---	---	---

A,B,C : SIZE(INCH)
E : MONTH

D : YEAR
F ~ M : SERIAL NO.

Note

1. YEAR

Year	2001	2002	2003	2004	2005	2006	2007	2008	2009	2010
Mark	1	2	3	4	5	6	7	8	9	0

2. MONTH

Month	Jan	Feb	Mar	Apr	May	Jun	Jul	Aug	Sep	Oct	Nov	Dec
Mark	1	2	4	4	5	6	7	8	9	A	B	C

b) Location of Lot Mark

Serial NO. is printed on the label. The label is attached to the backside of the LCD module.
This is subject to change without prior notice.

8-2. Packing Form

a) Package quantity in one pallet : 16 pcs

b) Pallet Size : 1300mm X 1140mm X 860mm

Product Specification

9. Precautions

Please pay attention to the followings when you use this TFT LCD module.

9-1. Mounting Precautions

- (1) You must mount a module using holes arranged in four corners or four sides.
- (2) You should consider the mounting structure so that uneven force (ex. Twisted stress) is not applied to the module. And the case on which a module is mounted should have sufficient strength so that external force is not transmitted directly to the module.
- (3) Please attach the surface transparent protective plate to the surface in order to protect the polarizer. Transparent protective plate should have sufficient strength in order to resist external force.
- (4) You should adopt radiation structure to satisfy the temperature specification.
- (5) Acetic acid type and chlorine type materials for the cover case are not desirable because the former generates corrosive gas of attacking the polarizer at high temperature and the latter causes circuit break by electro-chemical reaction.
- (6) Do not touch, push or rub the exposed polarizers with glass, tweezers or anything harder than HB pencil lead. And please do not rub with dust clothes with chemical treatment. Do not touch the surface of polarizer for bare hand or greasy cloth.(Some cosmetics are detrimental to the polarizer.)
- (7) When the surface becomes dusty, please wipe gently with absorbent cotton or other soft materials like chamois soaks with petroleum benzene. Normal-hexane is recommended for cleaning the adhesives used to attach front / rear polarizers. Do not use acetone, toluene and alcohol because they cause chemical damage to the polarizer.
- (8) Wipe off saliva or water drops as soon as possible. Their long time contact with polarizer causes deformations and color fading.
- (9) Do not open the case because inside circuits do not have sufficient strength.
- (10) If there is external force to LCM, it can effect to bend the slim. Since the bending, Lamp Mura can be shown on display.

9-2. Operating Precautions

- (1) The spike noise causes the mis-operation of circuits. It should be lower than following voltage :
 $V = \pm 200\text{mV}$ (Over and under shoot voltage)
- (2) Response time depends on the temperature.(In lower temperature, it becomes longer.)
- (3) Brightness depends on the temperature. (In lower temperature, it becomes lower.)
 And in lower temperature, response time(required time that brightness is stable after turned on) becomes longer
- (4) Be careful for condensation at sudden temperature change. Condensation makes damage to polarizer or electrical contacted parts. And after fading condensation, smear or spot will occur.
- (5) When fixed patterns are displayed for a long time, remnant image is likely to occur.
- (6) Module has high frequency circuits. Sufficient suppression to the electromagnetic interference shall be done by system manufacturers. Grounding and shielding methods may be important to minimized the interference.
- (7) Please do not give any mechanical and/or acoustical impact to LCM. Otherwise, LCM can't be operated its full characteristics perfectly.
- (8) A screw which is fastened up the steels should be a machine screw.
 (if not, it can causes conductive particles and deal LCM a fatal blow)
- (9) Please do not set LCD on its edge.
- (10) It is recommended to avoid the signal cable and conductive material over the inverter transformer for it can cause the abnormal display and temperature rising.
- (11) Partial darkness may happen during 3~5 minutes when LCM is operated initially in condition that luminance is under 40% at low temperature (under 5°C). This phenomenon which disappears naturally after 3~5 minutes is not a problem about reliability but LCD characteristic

Product Specification

9-3. Electrostatic Discharge Control

Since a module is composed of electronic circuits, it is not strong to electrostatic discharge. Make certain that treatment persons are connected to ground through wrist band etc. And don't touch interface pin directly.

9-4. Precautions for Strong Light Exposure

Strong light exposure causes degradation of polarizer and color filter.

9-5. Storage

When storing modules as spares for a long time, the following precautions are necessary.

- (1) Store them in a dark place. Do not expose the module to sunlight or fluorescent light. Keep the temperature between 5°C and 35°C at normal humidity.
- (2) The polarizer surface should not come in contact with any other object.
It is recommended that they be stored in the container in which they were shipped.

9-6. Handling Precautions for Protection Film

- (1) The protection film is attached to the bezel with a small masking tape.
When the protection film is peeled off, static electricity is generated between the film and polarizer.
This should be peeled off slowly and carefully by people who are electrically grounded and with well ion-blown equipment or in such a condition, etc.
- (2) When the module with protection film attached is stored for a long time, sometimes there remains a very small amount of glue still on the bezel after the protection film is peeled off.
- (3) You can remove the glue easily. When the glue remains on the bezel surface or its vestige is recognized, please wipe them off with absorbent cotton waste or other soft material like chamois soaked with normal-hexane.

Product Specification

APPENDIX- I-1

Required signal assignment for Flat Link (Thine : THC63LVD103) Transmitter (Pin7="L or NC")

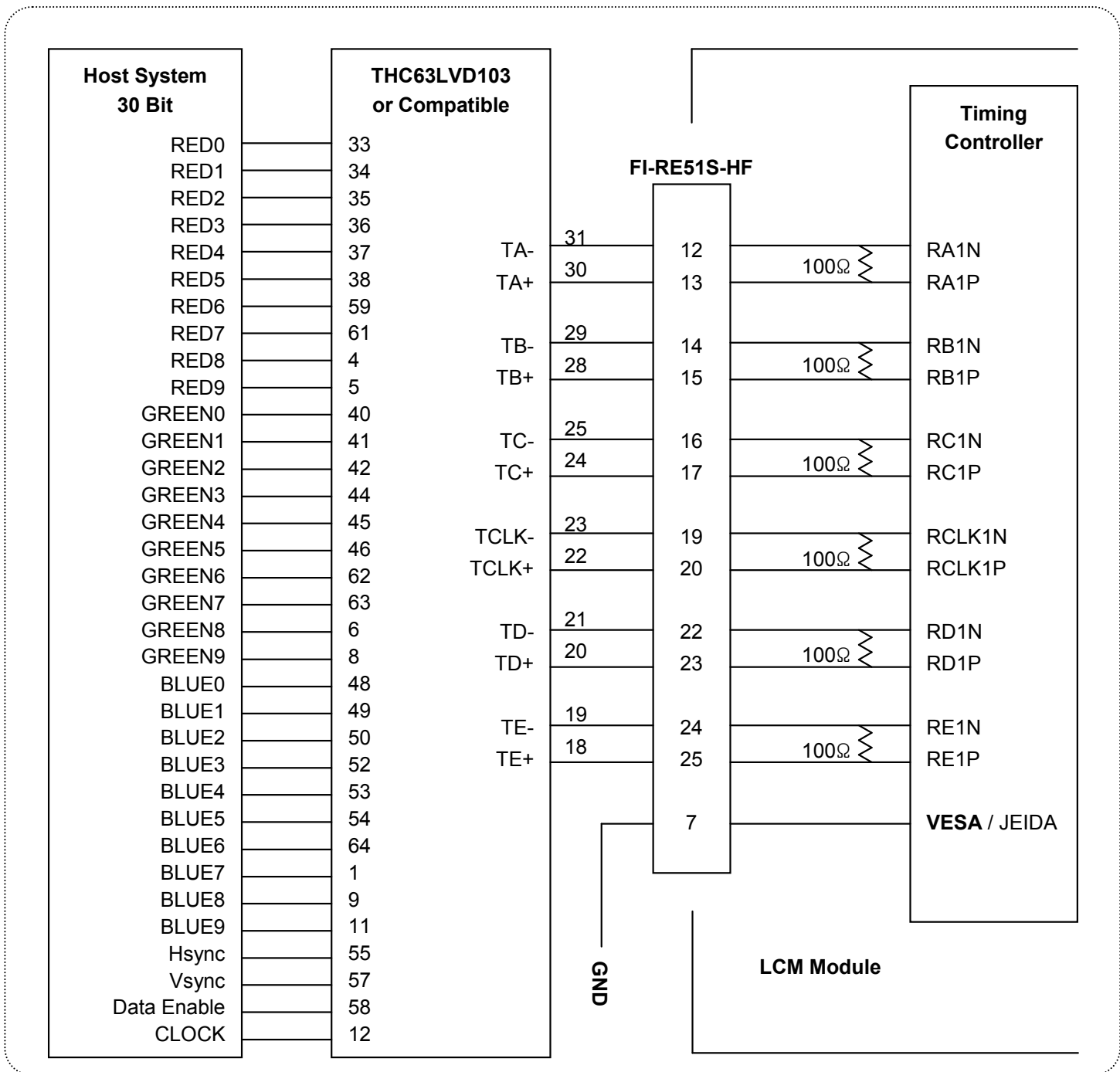

Notes:

1. The LCD module uses a 100 Ohm(Ω) resistor between positive and negative lines of each receiver input.
2. Refer to LVDS transmitter data sheet for detail descriptions. (THC63LVD103 or Compatible)
3. '9' means MSB and '0' means LSB at R,G,B pixel data.

Product Specification

APPENDIX- 1-2

■ Required signal assignment for Flat Link (Thine : THC63LVD103) Transmitter (Pin7="H")

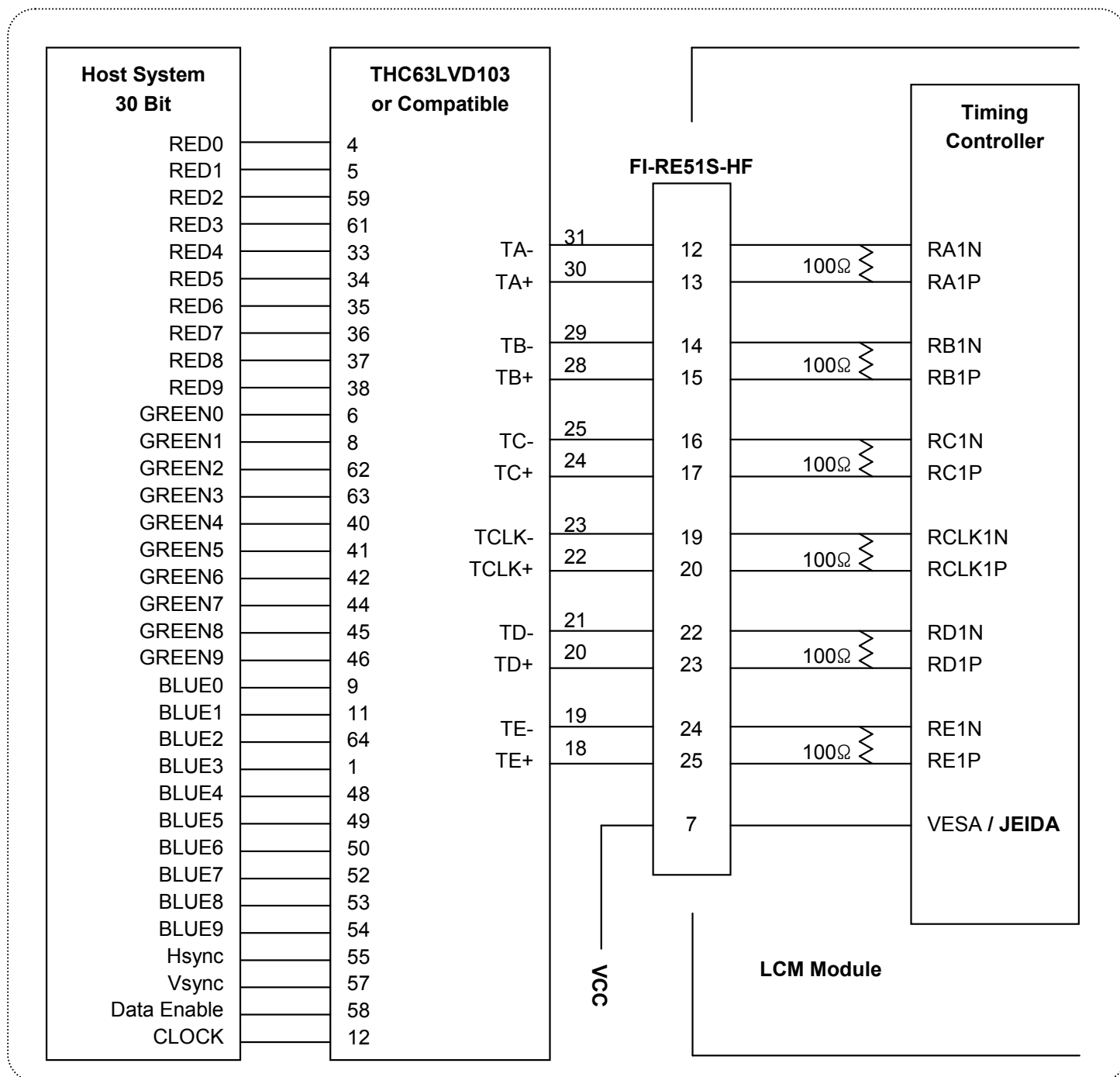

Notes:

1. The LCD module uses a 100 Ohm(Ω) resistor between positive and negative lines of each receiver input.
2. Refer to LVDS transmitter data sheet for detail descriptions. (THC63LVD103 or Compatible)
3. '9' means MSB and '0' means LSB at R,G,B pixel data.

Product Specification

APPENDIX-II

■ Pallet Ass'y

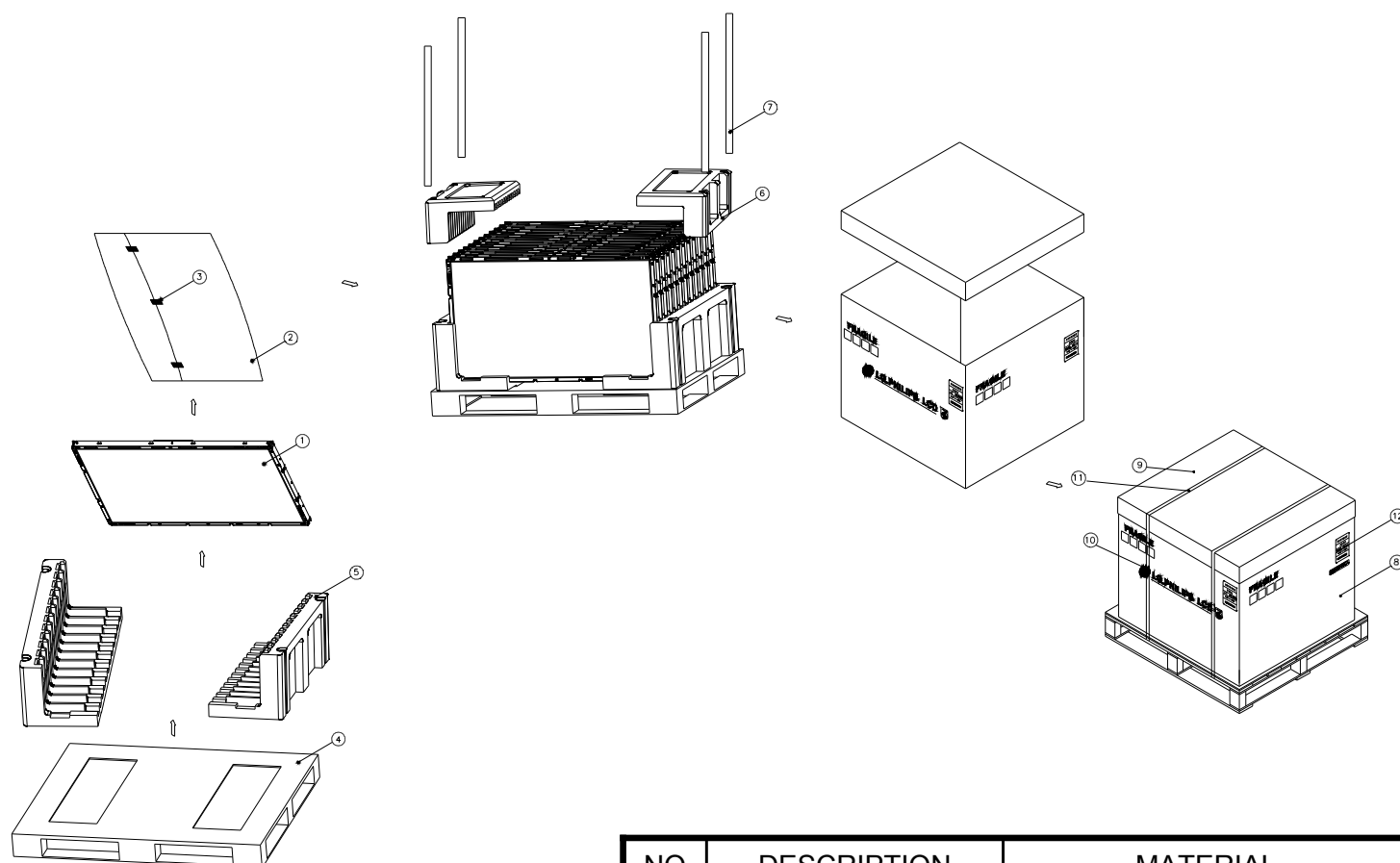

NO.	DESCRIPTION	MATERIAL
1	LCD Module	
2	BAG	47INCH
3	TAPE	MASKING
4	PALLET	PAPER 1300X1140X130MM
5	PACKING,BOTTOM	EPS
6	PACKING, TOP	EPS
7	ANGLE,POST	PAPER
8	ANGLE,PACKING	PAPER
9	ANGLE,COVER	PAPER
10	BAND,CLIP	STEEL
11	BAND	PP
12	LABEL	YUPO 80G 100X100

Product Specification

APPENDIX- III

■ LCM Label

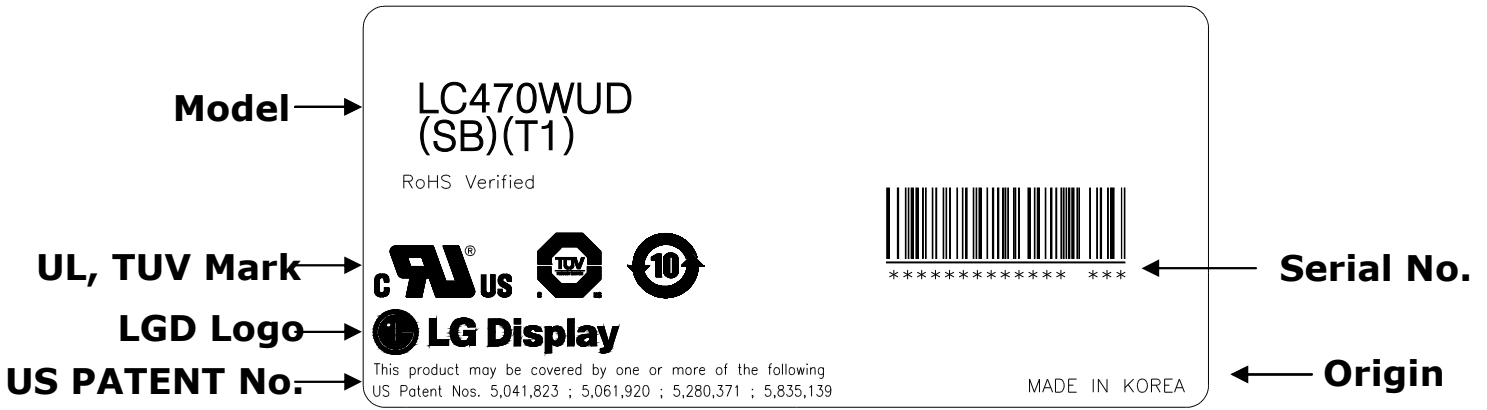

APPENDIX- IV

■ Pallet Label

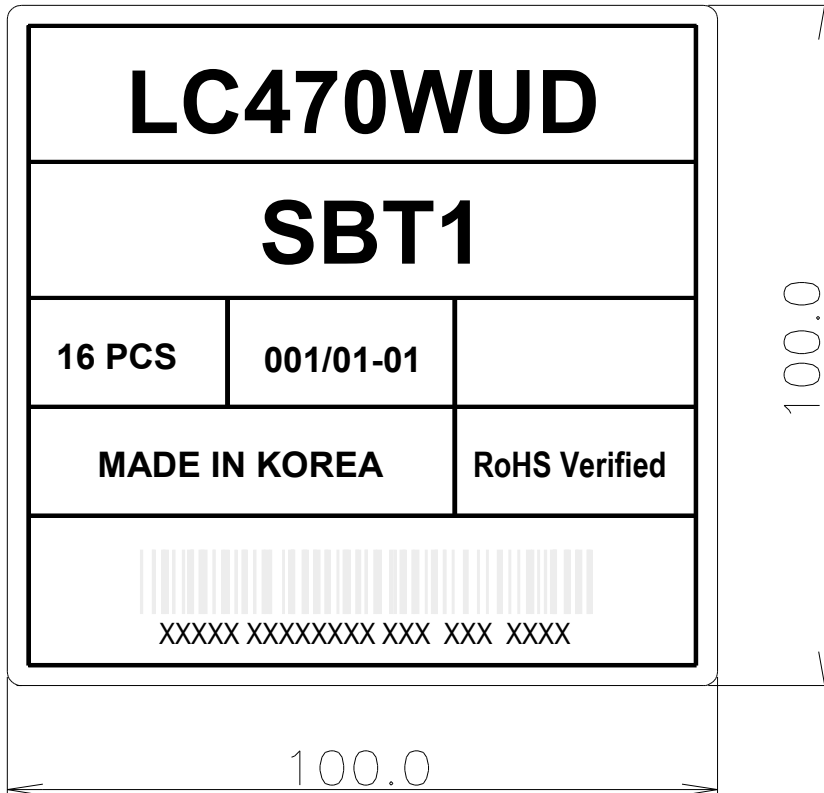

APPENDIX- V

Inverter 13th Pin (EXTVBR-B) Design Guide

- ◇ When OPC Enable is "L", OPC Output = System Dimming.
OPC Output(PWM Signal) is synchronized with V-Sync Freq. of System in T-Con Board.
- ◇ Regardless of OPC, System should always give dimming Signal (EXTVBR-B) to T-con.

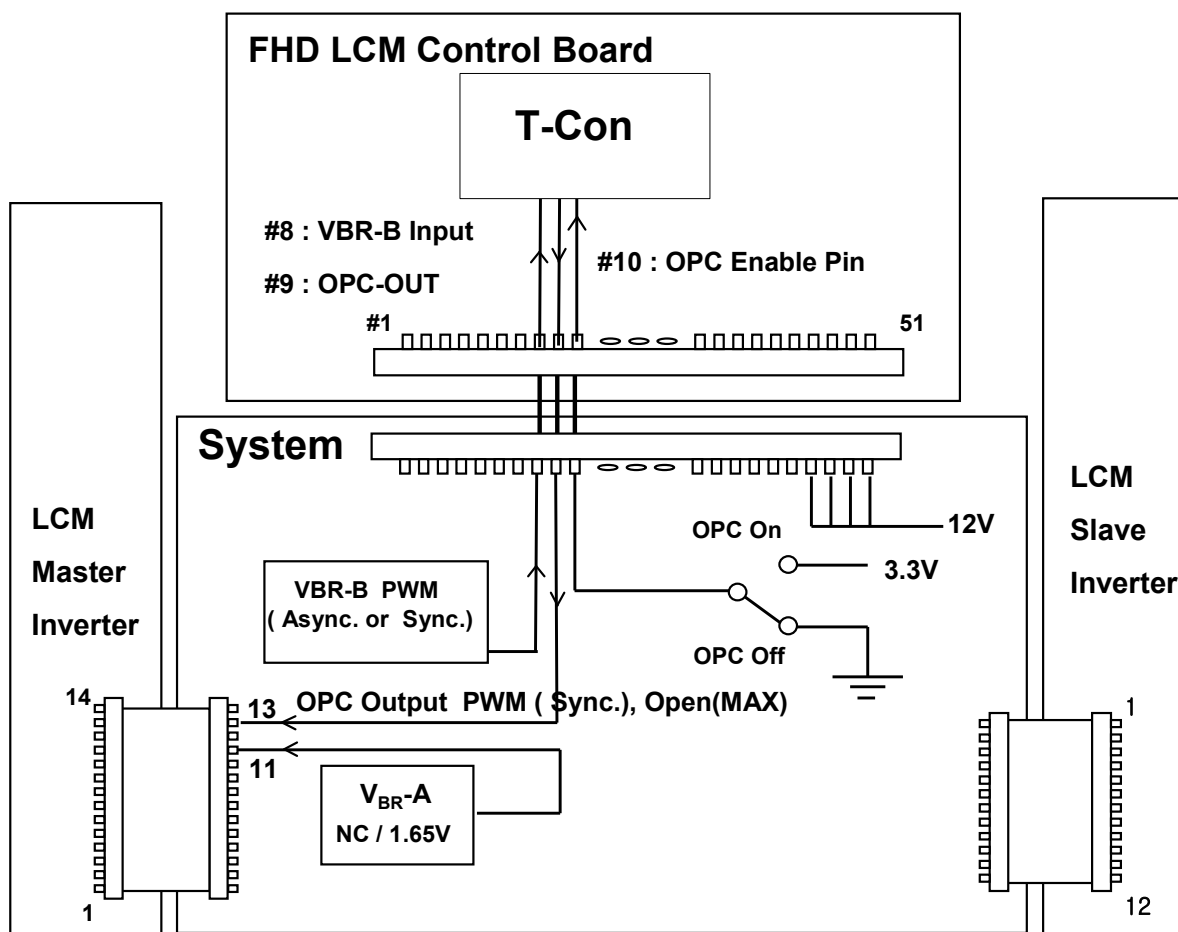

- ◇ PWM Specification (VDD = 3.3V) @ OPC
 1. PWM High Voltage Range : 2.5V~3.6V
 2. PWM Low Voltage Range : 0.0V~0.8V

Input Frequency	MAX 1Khz (Recommendation:50~300Hz)
Rising Time	MAX 10.0 μ s
Falling Time	MAX 10.0 μ s

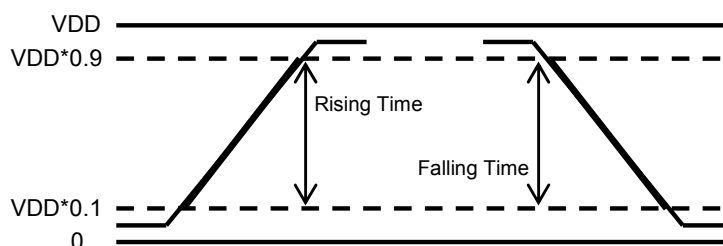

APPENDIX- VI

Inverter 14th Pin (Status) Design Guide

□ Function of Status pin

- Purpose : Preventing of backlight off by restarting the inverter technically
- How to : When inverter is abnormal operation, TV system inputs the Von signal in the inverter once more to turn on the lamp safely
- Attention : Restart system's Von signal when status signal is high for some time(min:1sec , max:4sec)
(The turn on time of lamp can be late such as the low temperature or the storage time)

□ Status operation modes in TV set

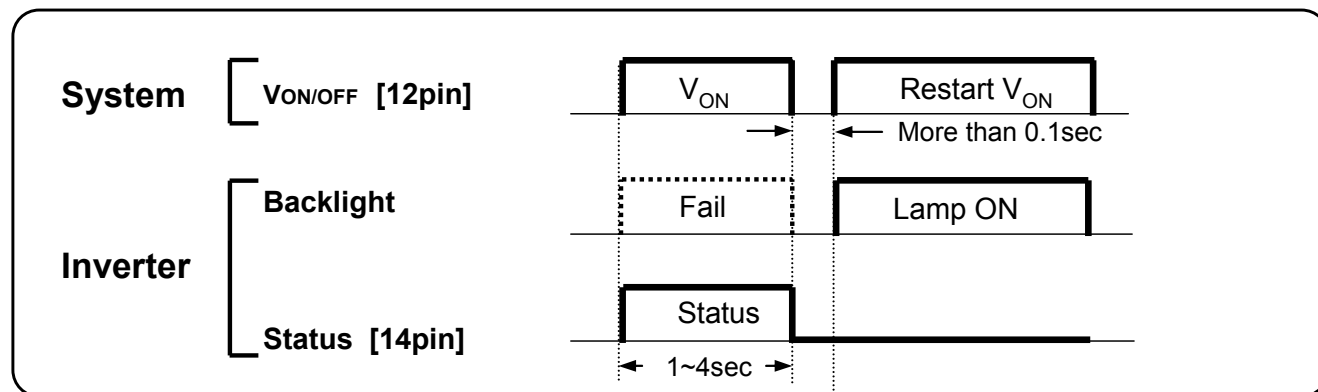
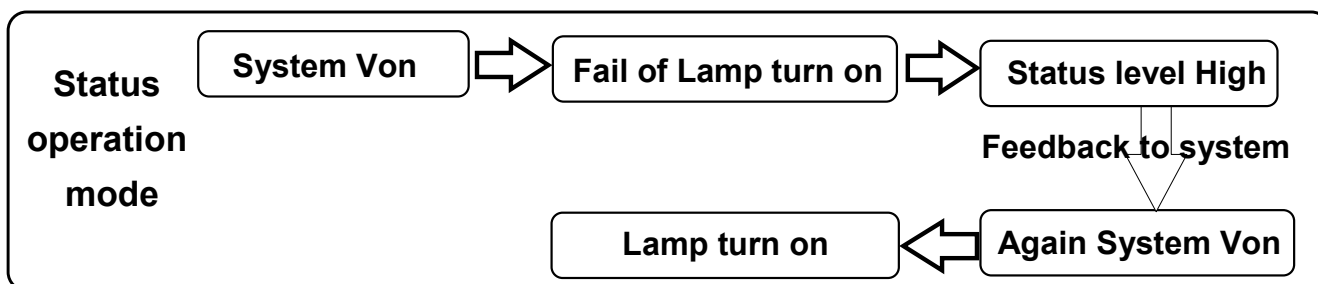
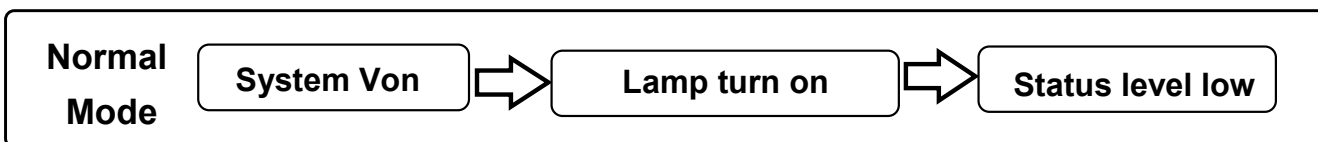

□ Inverter pin map

Pin No	Symbol	Description
11	VBR-A	Analog dimming Control (DC)
12	VON/OFF	On/Off Control
13	ExtVBR-B	Burst Dimming Control (PWM)
14	Status	Normal : Under 0.7V Abnormal : Upper 3.0V

APPENDIX- VII-1

Option Pin Circuit Block Diagram

Circuit Block Diagram of LVDS Format Selection pin

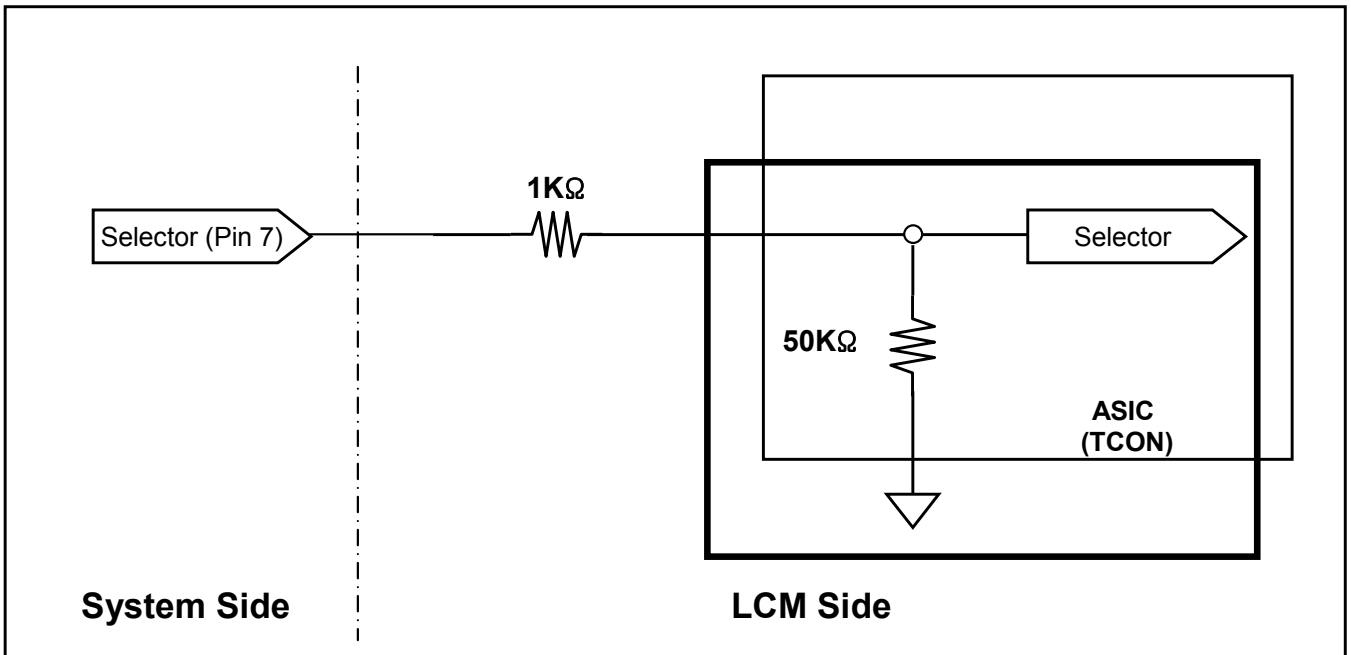

Circuit Block Diagram of Interlace Free Selection pin

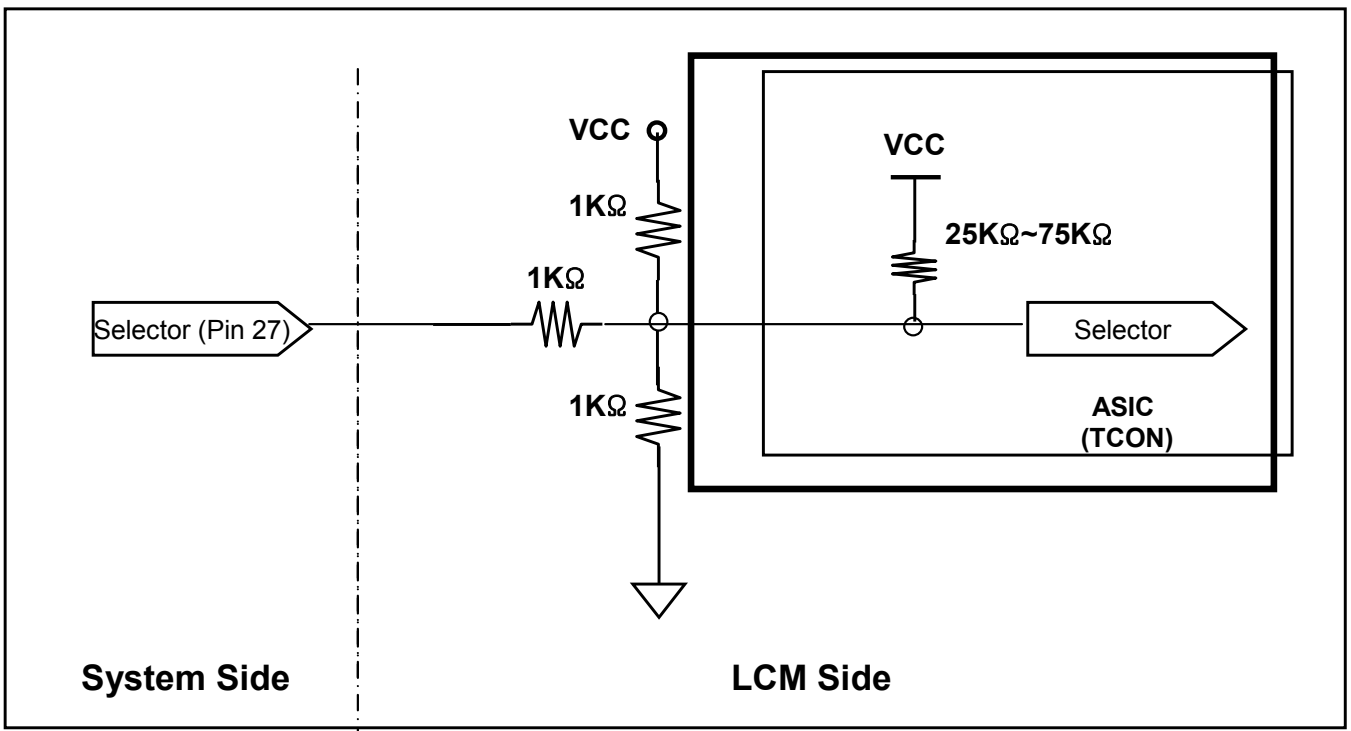

APPENDIX- VII-2

■ Option Pin Circuit Block Diagram

Circuit Block Diagram of OPC Enable Selection pin

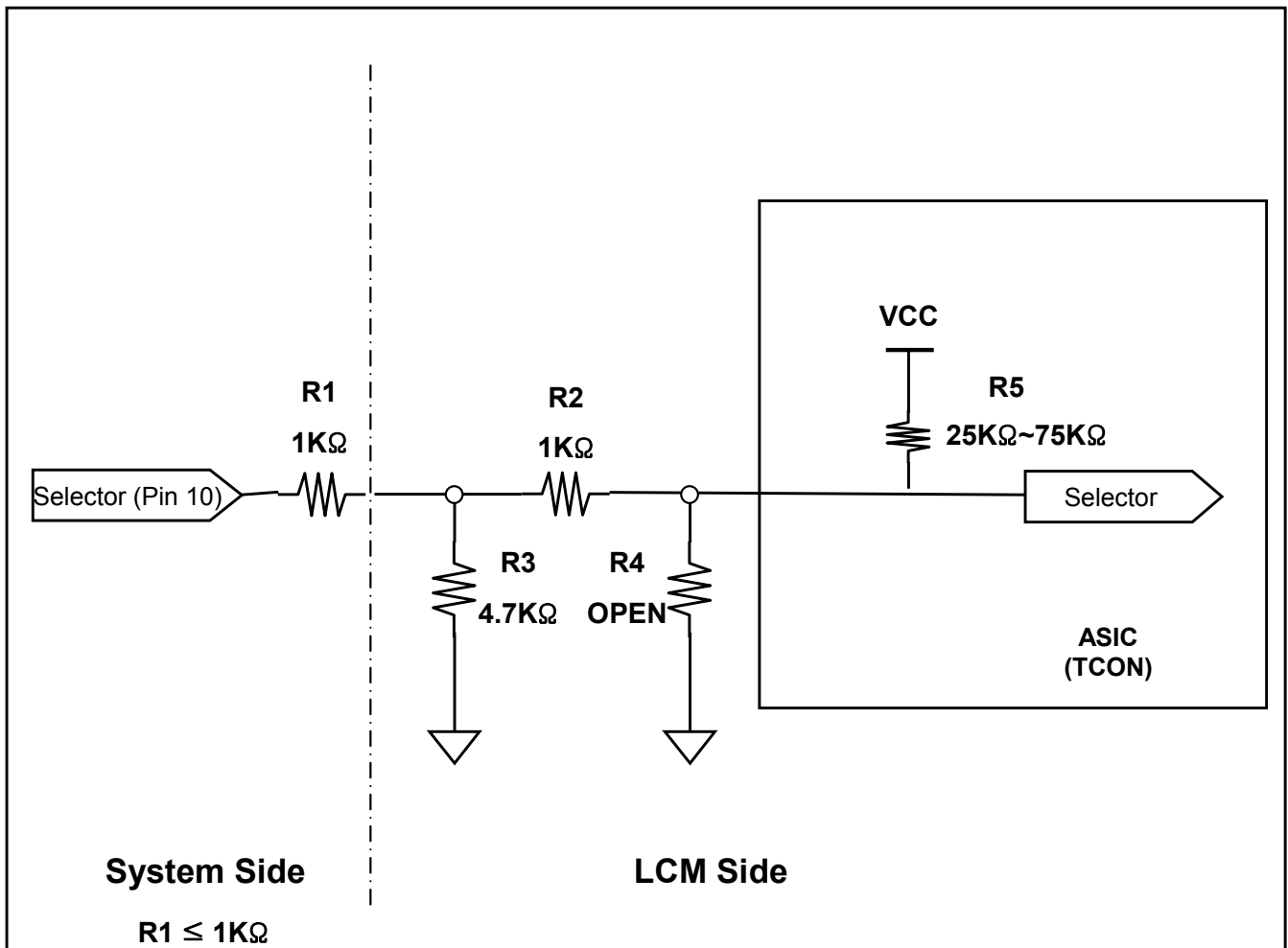

Product Specification

APPENDIX- VIII-1

LVDS Input characteristics

1. DC Specification

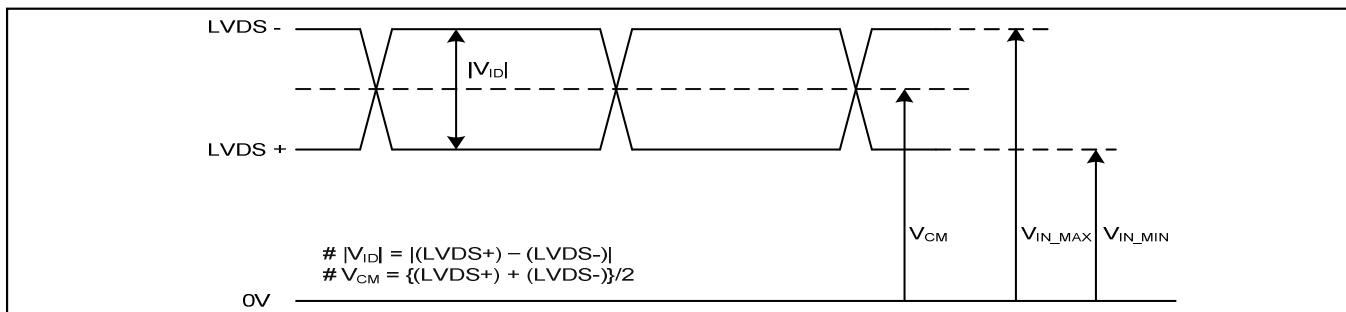

Description	Symbol	Min	Max	Unit	Notes
LVDS Single end Voltage	$ V_{ID} $	200	600	mV	-
LVDS Common mode Voltage	V_{CM}	1.0	1.5	V	-
LVDS Input Voltage Range	V_{IN}	0.7	1.8	V	-
Change in common mode Voltage	ΔV_{CM}		250	mV	-

2. AC Specification

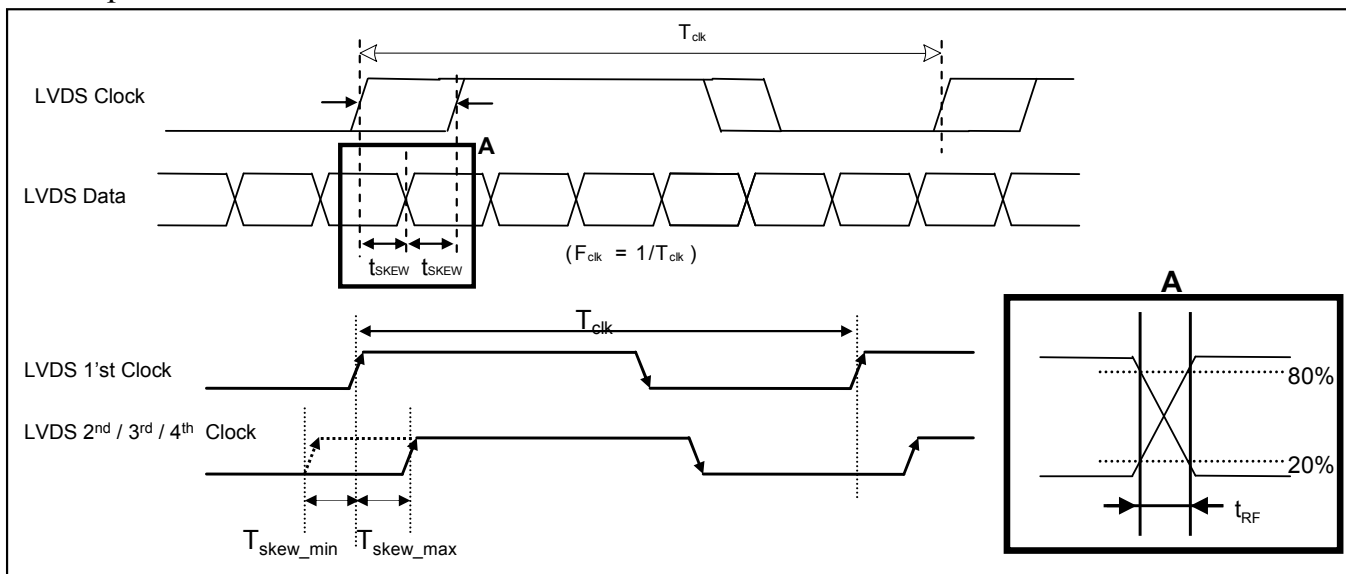

Description	Symbol	Min	Max	Unit	Notes
LVDS Clock to Data Skew Margin	t_{SKEW}		$(0.25 * T_{clk})/7$	ps	-
LVDS Clock/DATA Rising/Falling time	t_{RF}	260	$(0.3 * T_{clk})/7$	ps	2
Effective time of LVDS	t_{eff}	± 360		ps	-
LVDS Clock to Clock Skew Margin (Even to Odd)	t_{SKEW_EO}		$1/7 * T_{clk}$	T_{clk}	-

Notes : 1. All Input levels of LVDS signals are based on the EIA 644 Standard.
 2. If t_{RF} isn't enough, t_{eff} should be meet the range.

APPENDIX- VIII-2

LVDS Input characteristics

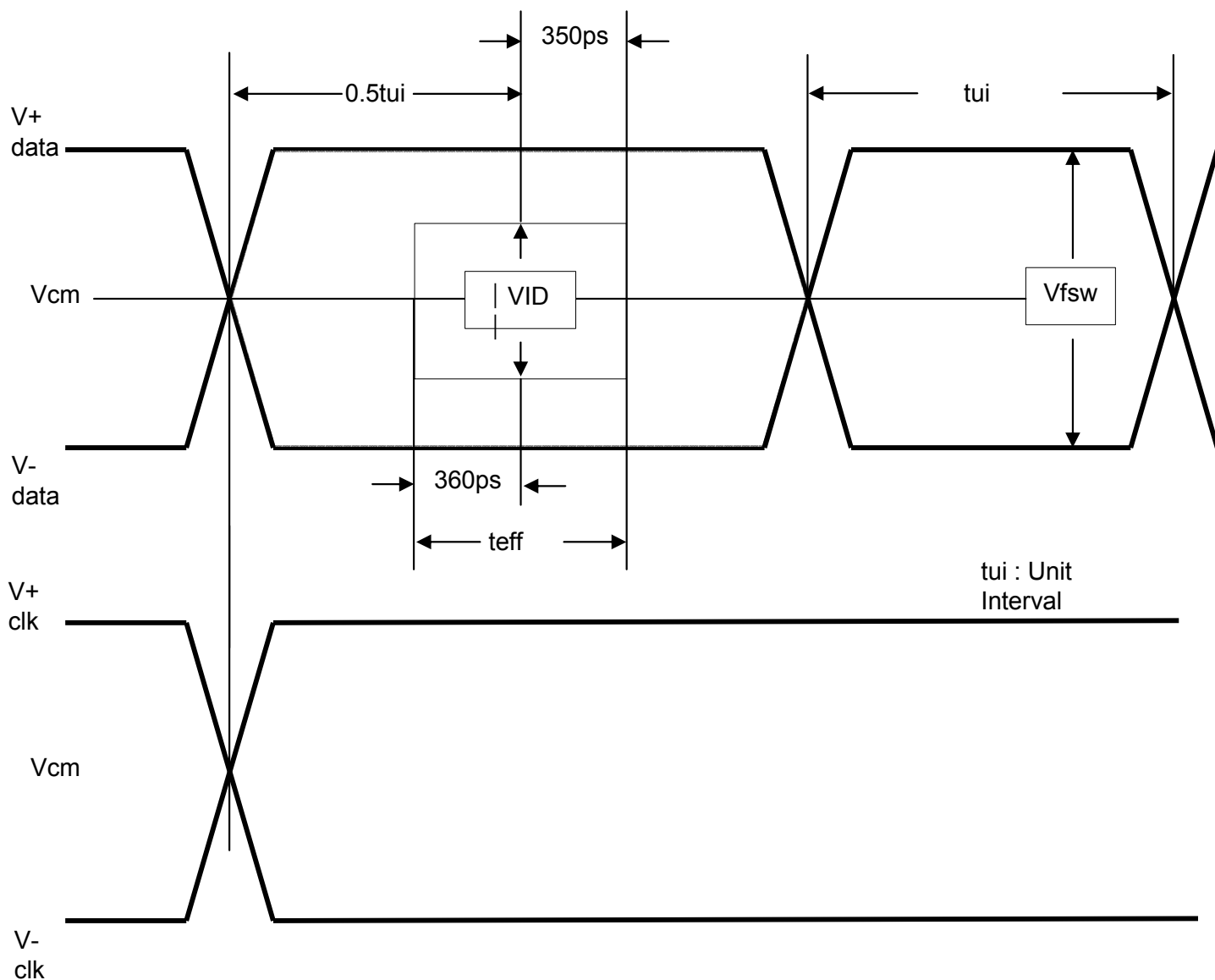

APPENDIX- IX-1

LVDS Data-Mapping info. (10bit)

■ LVDS Select : “H” Data-Mapping (JEIDA format)

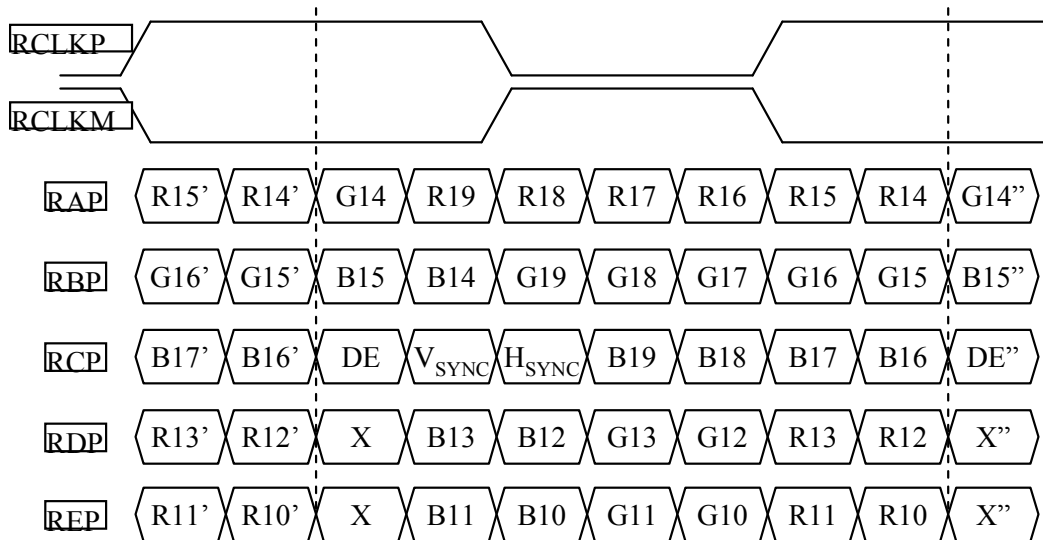

■ LVDS Select : “L” Data-Mapping (VESA format)

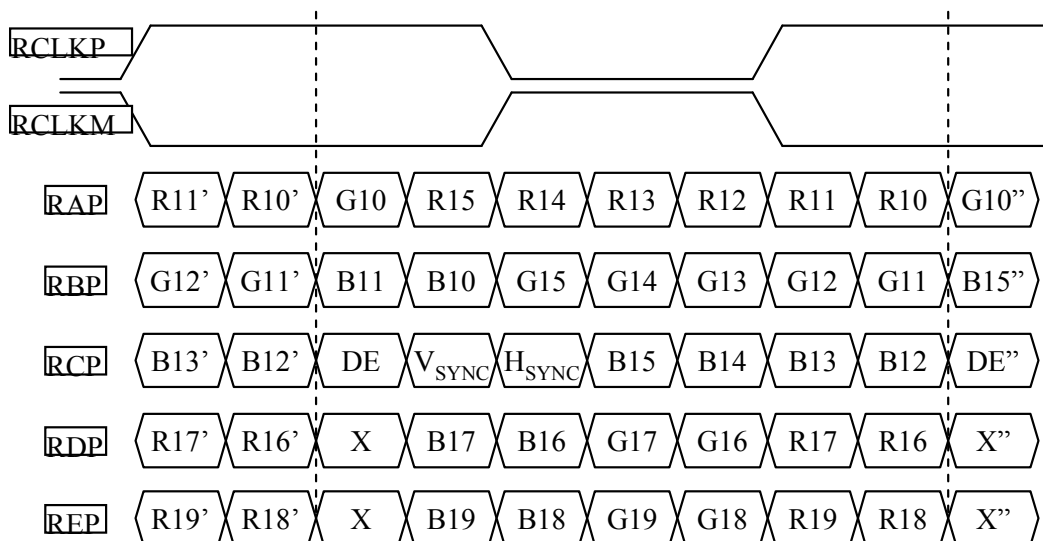

APPENDIX- IX-2

LVDS Data-Mapping info. (8bit)

■ LVDS Select : “H” Data-Mapping (JEIDA format)

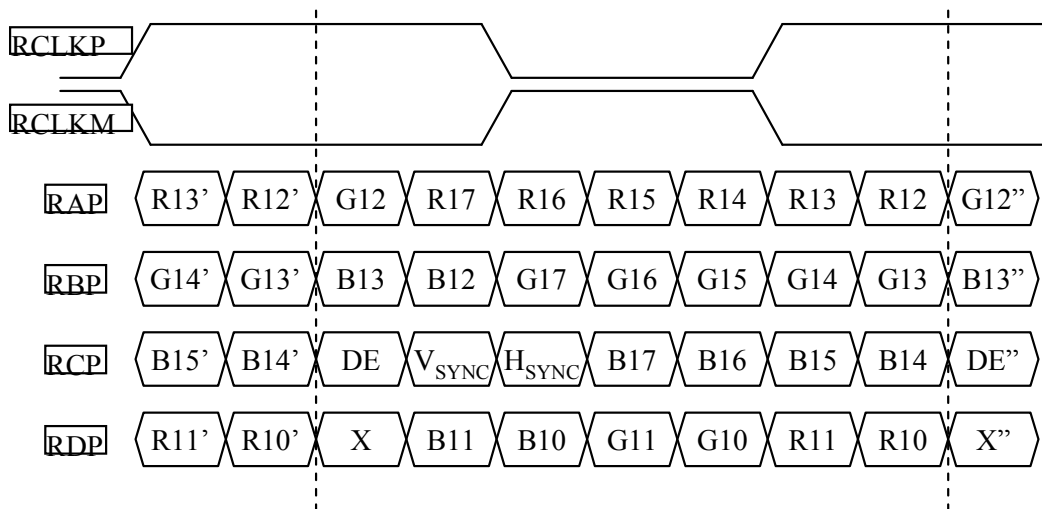

■ LVDS Select : “L” Data-Mapping (VESA format)

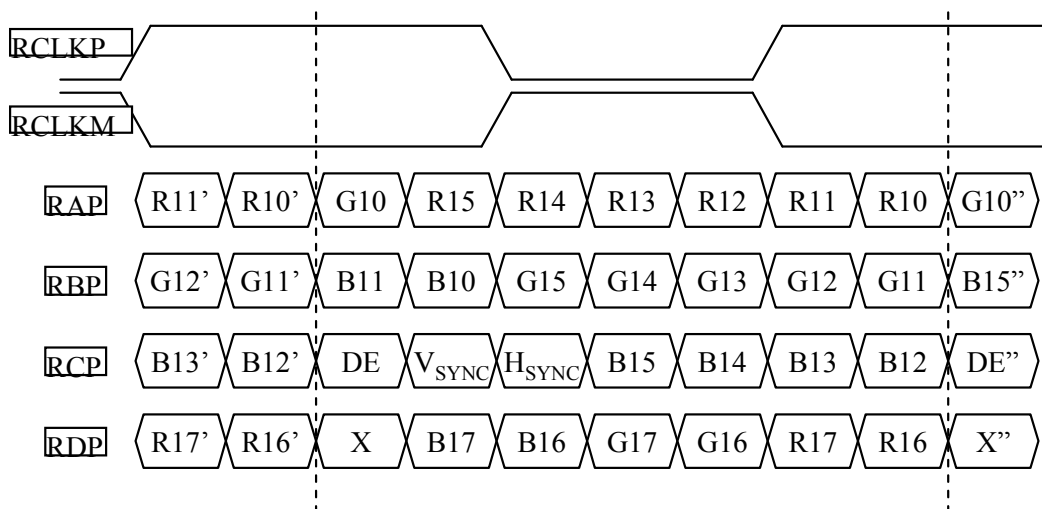

APPENDIX- X-1

Mega DCR using condition(1)

- It is recommended not to sustain more than 10 min for Deep Dimming (Low duty of the inverter output current 0%~20%). (About the input PWM duty see the table 3 on the page 7 (min duty)).

The deep dimming must be used very carefully due to limitation of lamp characteristics and specification.

- 1) For stable lamp on, its duty condition should follow below the condition.
After Inverter ON signal, T0 duration should be sustained.

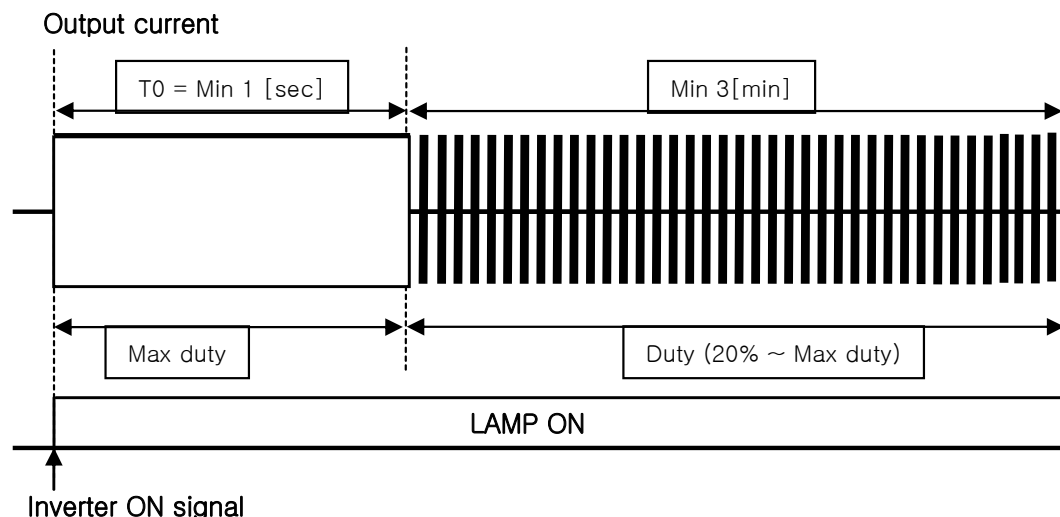

- 2) Low duty(0%~20%) of **the inverter output current**, B/L may not satisfy some of LCM specification.
 - Duration : the low duty operation(0 ~ 20%) must be limited within 10 minutes for one time operation.
 - Ratio : the period of the low duty operation must be less than 1/5 compare to that of the high duty operation(20~100%) in a certain period to prevent unwanted operation.
 - FOS : partial darkness or darkness of center area during the low duty might be happened due to insufficient lamp current.
 - Warm up : the low duty must be used 3 min after the lamps "ON". In case of low temperature, more warm up time may be needed.

APPENDIX- X-2

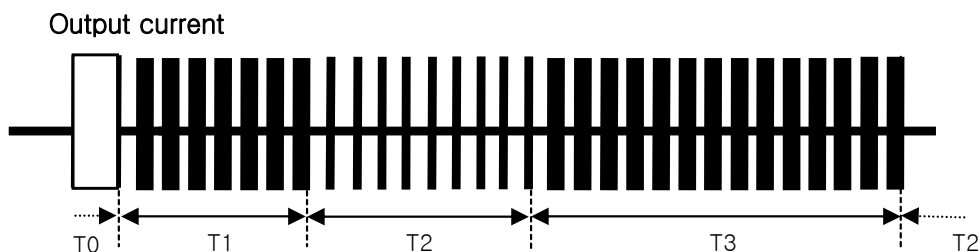
Mega DCR using condition(2)

Parameter	Value			Unit	Note
	Min	Typ	Max		
T1	3	-	-	min	Output Current Duty [20%~Max duty]
T2	-	-	10	min	Output Current Duty [0~20%]
T3	T2 x 5	-	-	min	Output Current Duty [20%~Max duty]

- 3) The output current duty may not be same as input PWM duty due to rise/fall time of output.
- 4) Following the recommended conditions as aforementioned, there is no difference of lamp lifetime between conventional method and new one.

Product Specification

APPENDIX- XII

Gray to Gray Response Time Uniformity

This is only the reference data of G to G and uniformity for LC470WUD-SBT1 model.

1. G to G Response Time :

Response time is defined as Figure3 and shall be measured by switching the input signal for “Gray (N)” and “Gray(M)”.(128 Gray Step at 10bit (D))

2. G to G Uniformity

The variation of G to G Uniformity , $\delta_{G \text{ to } G}$ is defined as :

$$\text{G to G Uniformity} = \frac{\text{Maximum}(G \text{ to } G) - \text{Typical}(G \text{ to } G)}{\text{Typical}(G \text{ to } G)} \leq 1$$

*Maximum (GtoG) means maximum value of measured time (N, M = 0 (Black) ~ 1023(White), 128 gray step).

	0Gray	127ray	255Gray	...	895Gray	1023Gray
0Gray		TrR:0G→127G	TrR:0G→255G	...	TrR:0G→895G	TrR:0G→1023G
127Gray	TrD:127G→0G		TrR:127G→255G	...	TrR:127G→895G	TrR:127G→1023G
255Gray	TrD:255G→0G	TrD:255G→127G		...	TrR:255G→895G	TrR:255G→1023G
...
895Gray	TrD:895G→0G	TrD:895G→127G	TrD:895G→255G	...		TrR:895G→1023G
1023Gray	TrD:1023G→0G	TrD:1023G→127G	TrD:1023G→255G	...	TrD:1023G→895G	

3. Sampling Size : 2 pcs

4. Measurement Method : Follow the same rule as optical characteristics measurement.

5. Current Status

Below table is actual data of production on 2009.01.23 (LGD RV Event Sample)

	G to G Response Time [ms]		Uniformity
	Min.	Max.	
# 1	3.9	6.9	0.38
# 2	3.8	6.7	0.34

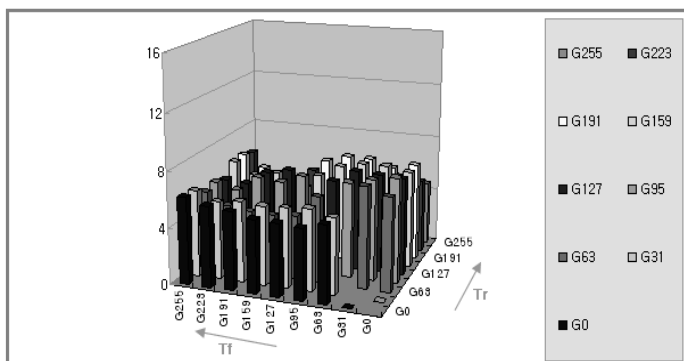

< # 1 >

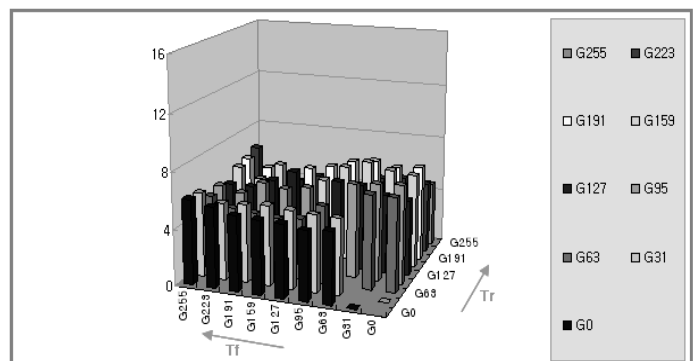

< # 2 >