

Off-Line DC/DC LED Driver ICs

Features and Benefits

- Buck and buck-boost topology; selectable by peripheral circuit structure
- Built-in fixed reference voltage limiting constant current control; high precision regulator improves current precision and simplifies setting of current level
- Sleep function, with latch mode; input high, 3 V or more, on REF pin turns off IC output to LEDs
- Enable function; input low on REF pin toggles IC output to LEDs
- High input voltage; up to 250 V or 450 V, depending on product
- Output Current: 0.5A
- Built-in constant current control; PWM method, output current adjustable by the voltage input on the REF pin
- External adjustable PWM dimming control
- Protection features:
 - Open protection (OPP) with latched shutdown; protects IC when a free-wheeling diode is open
 - Undervoltage lockout (UVLO)
 - Overcurrent protection (OCP) with latched shutdown; variable OCP threshold linked to REF pin voltage
 - Thermal shutdown (TSD) with auto restart

Packages



Description

LC5220 series is a non-isolating, simple and efficient LED driver. The high voltage capability allows direct connection to a wide range of supply voltages ranging from 25 to 400 V (recommended). The LC5220 uses constant current mode to drive LEDs, and buck and buck-boost voltage converters can be configured.

A power MOSFET and controller IC are incorporated in one package. Because few external parts are required, the LC5220 is ideal for use in small-size LED light bulbs.

Various control requirements can be supported through the REF pin, including peak current control, output on/off, and sleep mode enable.

Moreover, there is a protection circuit for freewheeling diode open, protection for a buck-boost voltage converter open LED load, and a variable overcurrent protection function. These features improve safety for both the LC5220 and the LEDs.

Applications

- LED lighting fixtures
- LED light bulbs

Typical Application

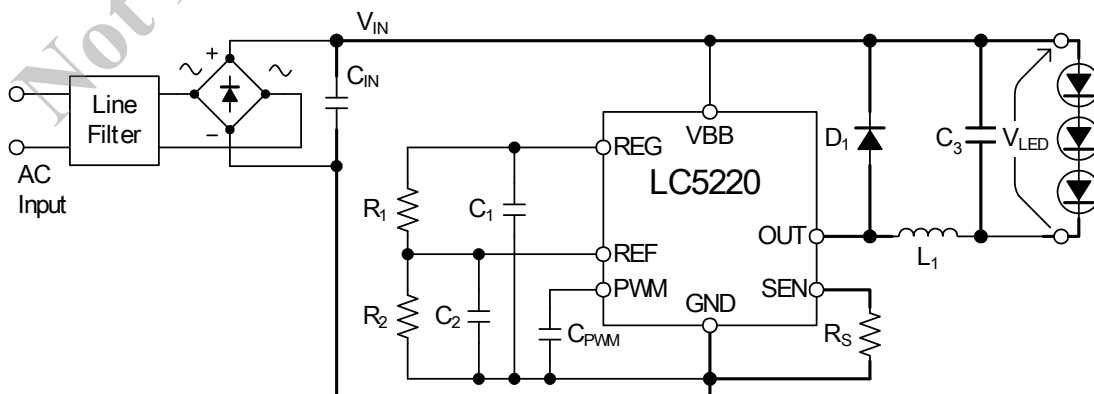

An example of a buck voltage converter application circuit

Selection Guide

Part Number	Package	Maximum Input Voltage $V_{BB(max)}$ (V)	Output MOSFET $R_{DS(ON)(max)}$ (Ω)
LC5222D	DIP8	250	2.2
LC5225D		450	6
LC5222S	SOP8	250	2.2
LC5225S		450	6

The polarity value for current specifies a sink as "+," and a source as "-", referencing the IC.

Absolute Maximum Ratings Unless specifically noted, T_A is 25°C

Characteristic	Symbol	Notes	Pins ¹	Rating	Unit	
Main Power Supply Voltage	V_{BB}	LC5222D/S	6 – 8	250	V	
		LC5225D/S	(7 – 8)	450	V	
Output Breakdown Voltage	$V_{O(BR)}$	LC5222D/S	5 – 4	250	V	
		LC5225D/S	(5, 6 – 4)	450	V	
Output Current ²	I_O	Pulse width $\geq 1 \mu s$	5 – 4 (5, 6 – 4)	0.5	A	
PWM Pin Voltage ³	V_{PWM}		2 – 8	-0.3 to V_Z	V	
REF Pin Input Voltage ³	V_{REF}		3 – 8	-0.3 to V_Z	V	
SEN Pin Voltage	V_{SEN}	Pulse width $\geq 1 \mu s$	4 – 8	-0.3 to 4.0	V	
Allowable Power Dissipation ^{4,5}	P_D	LC5222S	On Sanken evaluation PCB	—	0.85	W
		LC5225S				
		LC5222D		—	1.73	W
		LC5225D				
Operating Ambient Temperature	T_A		—	-40 to 105	°C	
Storage Temperature	T_{stg}		—	-40 to 150	°C	
Junction Temperature	T_J		—	150	°C	

¹Where the pin numbers differ between the DIP8 and the SOP8 packages, the SOP8 pin number is written in parentheses.

²The output current value may be restricted based on duty cycle, ambient air temperature, or heat dissipation conditions. In any case, please be sure to keep from exceeding the junction temperature, T_J .

³Zener diodes are built-in between the PWM pin and GND, and between the REF pin and GND. V_Z is the breakdown voltage of these internal Zener diodes, and $V_Z = 6.3 V$ (typ). In addition, the maximum sink current is 1 mA.

⁴Allowable loss, P_D , is dependent on the circuit layout of the PCB to be used.

⁵Please refer to the Ambient Temperature versus Power Dissipation Curve.

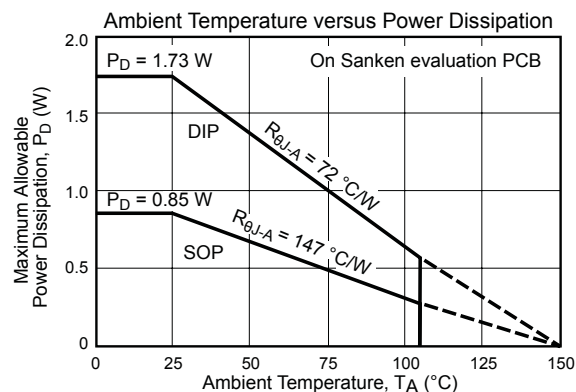

Recommended Operating Conditions

Characteristic	Symbol	Test Conditions	Pins*	Min.	Max.	Unit
Power Supply Voltage	V _{BB}	LC5222D/S	6 – 8 (7 – 8)	25	200	V
		LC5225D/S		25	400	V
Average Output Current	I _{O(AVG)}		5 – 4 (5, 6 – 4)	—	0.4	A
REF Pin Input Voltage	V _{REF}	Normal operation	3 – 8	0.2	2.5	V
Case Temperature	T _C	Measured at the center of the branded side, T _J ≤ 150°C.	—	—	105	°C

Note: Recommended Operating Conditions means the operation conditions to maintain normal functions shown in the Electrical Characteristics table.
*Where the pin numbers differ between the DIP8 and the SOP8 packages, the SOP8 pin number is written in parentheses.

Not Recommended for New Designs

Electrical Characteristics Unless specifically noted, T_A is 25°C, $V_{BB} = 140$ V

Characteristic	Symbol	Test Conditions	Pins ¹	Min.	Typ.	Max.	Unit
Power Supply Current	I_{BBS}	Output off	6-8 (7-8)	—	1	1.5	mA
	I_{BB}	Normal operation	6-8 (7-8)	—	2.5	4.0	mA
Output MOSFET Breakdown Voltage	$V_{(BR)DSS}$	LC5222D/S $I_D = 1$ mA	5-4	250	—	—	V
		LC5225D/S	(5, 6-4)	450	—	—	V
Output MOSFET On-Resistance	$R_{DS(ON)}$	LC5222D/S $I_D = 0.5$ A	5-4	—	1.2	2.2	Ω
		LC5225D/S $I_D = 0.5$ A	(5, 6-4)	—	3.5	6	Ω
Body Diode Forward Voltage	V_f	LC5222D/S $I_f = 0.5$ A	4-5	—	0.8	1.0	V
		LC5225D/S $I_f = 0.5$ A	(4-5, 6)	—	0.8	0.9	V
UVLO Threshold (Turn on)	$V_{UVLO(ON)}$	VBB pin voltage	6-8 (7-8)	—	14	—	V
UVLO Threshold (Turn off)	$V_{UVLO(OFF)}$	VBB pin voltage	6-8 (7-8)	—	12	—	V
REG Pin Output Voltage	V_{REG}	$I_{REG} = 0$ mA	1-8	9.6	10	10.4	V
REG Pin Output Current	I_{REG}	$V_{REG} = 9$ V	1-8	-2	—	—	mA
Enable Output Threshold Voltage	V_{ENB}	REF pin voltage	3-8	—	0.15	0.19	V
Sleep Mode Threshold Voltage	V_{SLP}	REF pin voltage	3-8	2.85	3.0	—	V
REF Pin Current	I_{REF}		3-8	-10	—	10	μ A
Current Control Detection Voltage ²	V_{SEN}	$V_{REF} = 0.2$ to 2.0 V	4-8	$0.4 \times V_{REF} - 0.03$	$0.4 \times V_{REF}$	$0.4 \times V_{REF} + 0.03$	V
		$V_{REF} = 2.0$ to 3.0 V		0.77	0.8	0.83	V
OCP Detection Voltage ²	V_{OCP}	$V_{REF} = 0.2$ to 2.0 V	4-8	—	$0.4 \times V_{REF} + 0.7$	—	V
		$V_{REF} = 2.0$ to 3.0 V		—	1.5	—	V
SEN Pin Current	I_{SEN}		4-8	-10	—	10	μ A
PWM Pin Low Voltage	$V_{PWM(L)}$		2-8	—	2	—	V
PWM Pin High Voltage	$V_{PWM(H)}$		2-8	—	3	—	V
PWM Pin Output Current	I_{PWM}		2-8	—	-20	—	μ A
PWM Blanking Time	$t_{BLK(P)}$		—	—	0.3	—	μ s
OCP Blanking Time	$t_{BLK(O)}$		—	—	0.2	—	μ s
PWM Operation Frequency	f_{PWM}	Duty cycle = 50%	2-8	—	—	200	kHz
PWM Off Time	t_{off}	$C_{PWM} = 100$ pF	—	—	17	—	μ s
Output MOSFET Rise Time	t_r	$I_O = 0.4$ A	5-4 (5, 6-4)	—	25	—	ns
Output MOSFET Fall Time	t_f	$I_O = 0.4$ A	5-4 (5, 6-4)	—	50	—	ns
Thermal Shutdown Threshold ³	T_{TSD}		—	—	150	—	°C
Thermal Shutdown Hysteresis ³	$T_{TSD(HYS)}$		—	—	55	—	°C

¹Where the pin numbers differ between the DIP8 and the SOP8 packages, the SOP8 pin number is written in parentheses.

²The REF pin has different functions, depending on the voltage. Please refer to REF Pin Voltage Characteristics section.

³Chip temperature of control IC, T_J .

REF Pin Voltage Characteristics

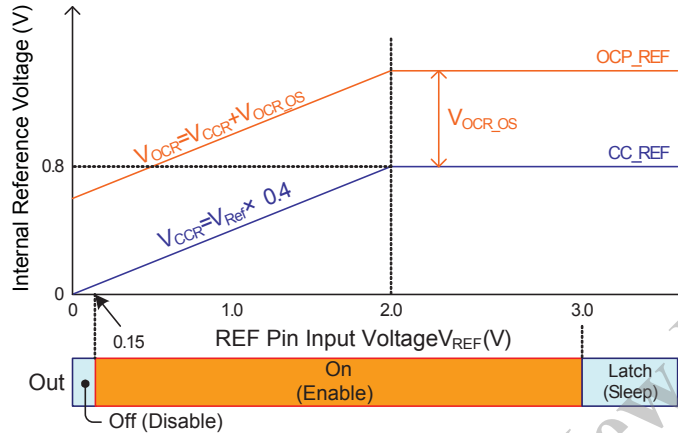

Function	Conditions
Internal PWM reference voltage, V_{CCR}	<ul style="list-style-type: none"> When $V_{REF} < 2$ V, $V_{CCR} = 0.4 \times V_{REF}$ (V) (V_{CCR} is proportional to V_{REF}) When $V_{REF} > 2$ V, $V_{CCR} = 0.8$ V
OCP reference voltage, V_{OCR}	V_{OCR} is offset from V_{CCR} by V_{OCR_OS} ; $V_{OCR_OS} = 0.7$ V (typ); V_{OCR} has negative temperature characteristics
Enable function	Enable mode is entered when $V_{REF} > V_{ENB}$; Enable mode is not latched, and the IC stops operating when V_{REF} falls below V_{ENB} ; $V_{ENB} = 0.15$ V (typ)
Sleep function	Sleep mode is entered when $V_{REF} > V_{SLP}$, turning off the output; $V_{ENB} = 3.0$ V (typ); Sleep mode is latched, and the latch is released when V_{BB} falls below $V_{UVLO(OFF)}$; $V_{UVLO(OFF)} = 12$ V (typ)

Functional Block Diagram

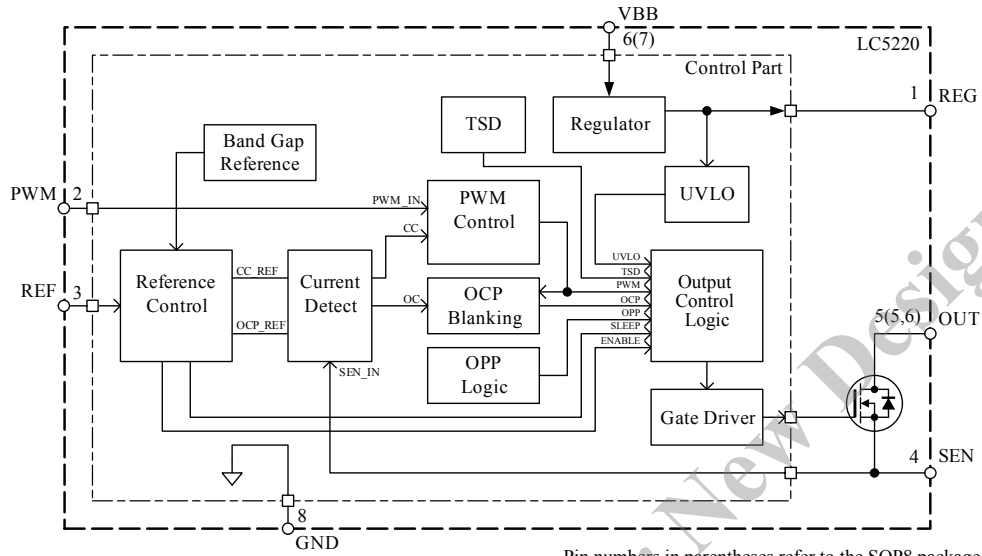

Pin numbers in parentheses refer to the SOP8 package

Pin List Table

Name	Number		Function
	DIP8	SOP8	
REG	1	1	Internal regulator supply, provides current to internal and external circuits; connect a 0.1 μ F bypass capacitor between this pin and GND.
PWM	2	2	Input for PWM control: to use internal PWM, connect a capacitor for setting off-time; to use external PWM, connect to PWM signal source.
REF	3	3	Reference voltage input: sets peak output current of OUT pin (internal power MOSFET) for internal PWM control, enables toggling output of OUT pin (Enable function), and enables latched shutdown of output (Sleep function)
SEN	4	4	Output current detection: detects peak output current for internal PWM control, and detects overcurrent for OCP; connect to current detection resistor.
OUT	5	5, 6	Drain of internal power MOSFET.
VBB	6	7	Supply voltage, provides power to internal circuits through internal regulator.
GND	8	8	Ground pin.
—	7	—	LC5220D DIP8 pin removed to increase creepage distance between high voltage pin and low voltage pin. Note: Apply user's criteria for creepage distance when using LC5220S SOP8.

Pin-out Diagrams

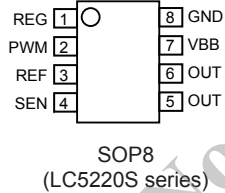
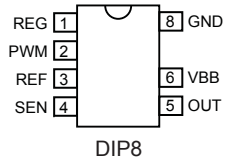

Reference Components List of a Buck Configuration Circuit

(refer to Typical Application diagram); Input voltage: 100 VAC, LED output voltage: 15 V,
LED peak output current : 0.3 A

Name	Type	Value	Description
LED	LED	—	User-defined
L ₁	Inductor	1 mH / 1 A	Choke coil for smoothing current
D ₁	Fast recovery rectifier diode	RD2A	Free-wheeling diode for recirculation
C _{IN}	Capacitor	Up to 4.7 μF / 450 V	Main supply source filtering capacitor; 1 nF or higher can be used
C ₁	Capacitor	0.1 μF / 25 V	Internal regulator stabilizing capacitor
C ₂	Capacitor	1000 pF (to 0.1 μF) / 25 V	REF pin voltage stabilizing capacitor
C ₃	Capacitor	0.1 μF / 250 V	Smoothing capacitor for reducing LED ripple current (Optional)
C _{PWM}	Capacitor	100 pF / 25 V	PWM off-time setting capacitor (internal PWM control)
R ₁	Resistor	620 kΩ / 1/8 W	Resistor for setting peak output current on OUT pin
R ₂	Resistor	51 kΩ / 1/8 W	Resistor for setting peak output current on OUT pin
R _S	Resistor	1.0 Ω / 1 W	Resistor for output current detection

Note: Because no specific application or noise factor is considered in the typical application circuit diagrammed, it is required that the user takes into consideration such issues during designing. Moreover, the above values are only reference examples. It is required to change components according to the LED load and other conditions which are actually used.

Package Outline Drawing, DIP8

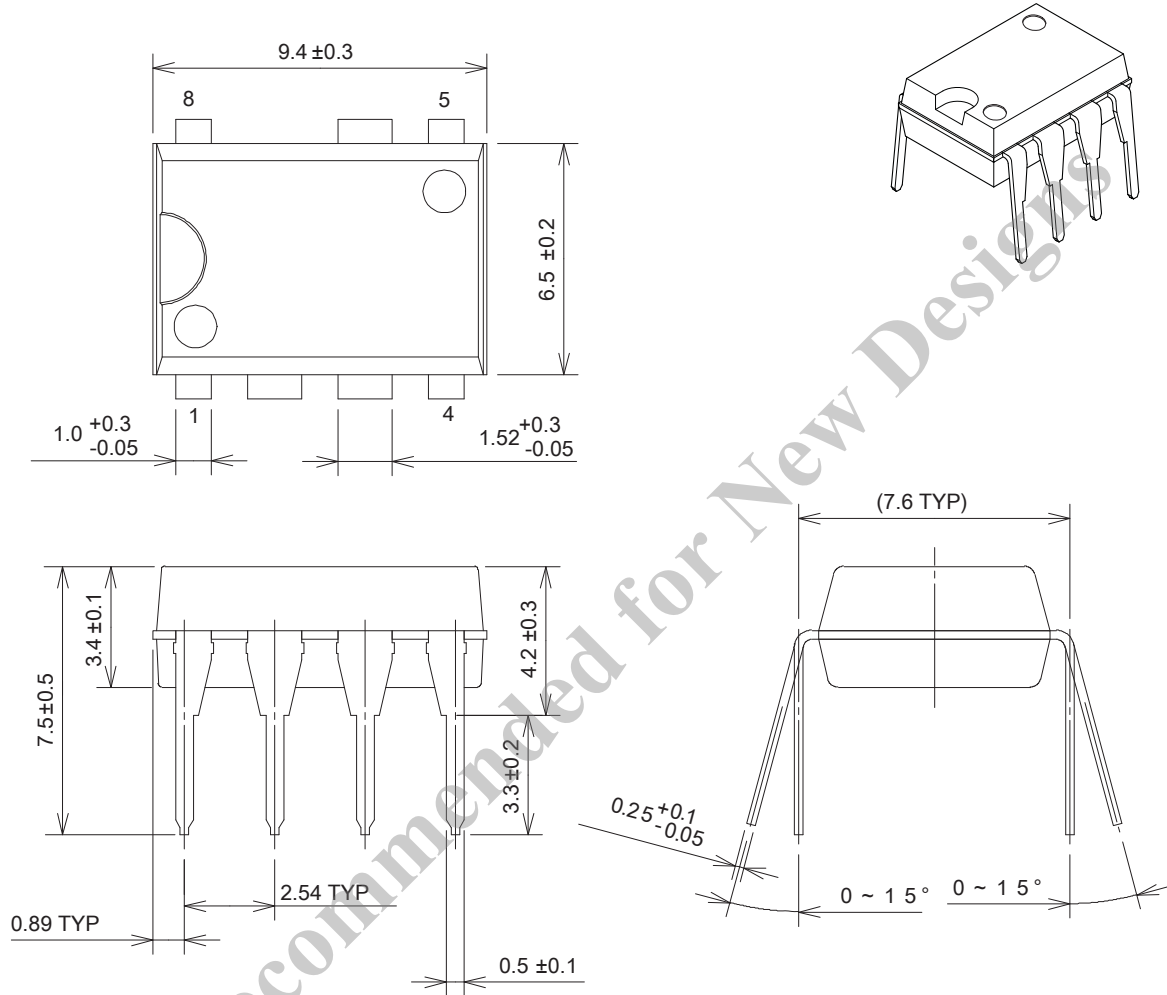

Unit: mm

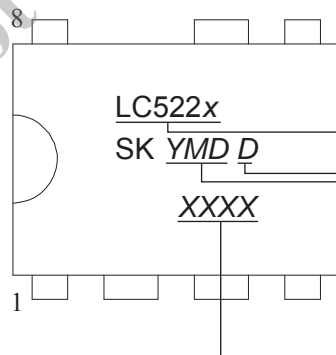

Part Number

Lot Number

Y is the last digit of the year (0 to 9)

M is the month (1 to 9, O, N, or D)

D is a period of days (1 to 3):

1 - 1st to 10th

2 - 11th to 20th

3 - 21st to 31st

Sanken Control Number



Pb-free. Device composition compliant
with the RoHS directive.

Package Outline Drawing, SOP8

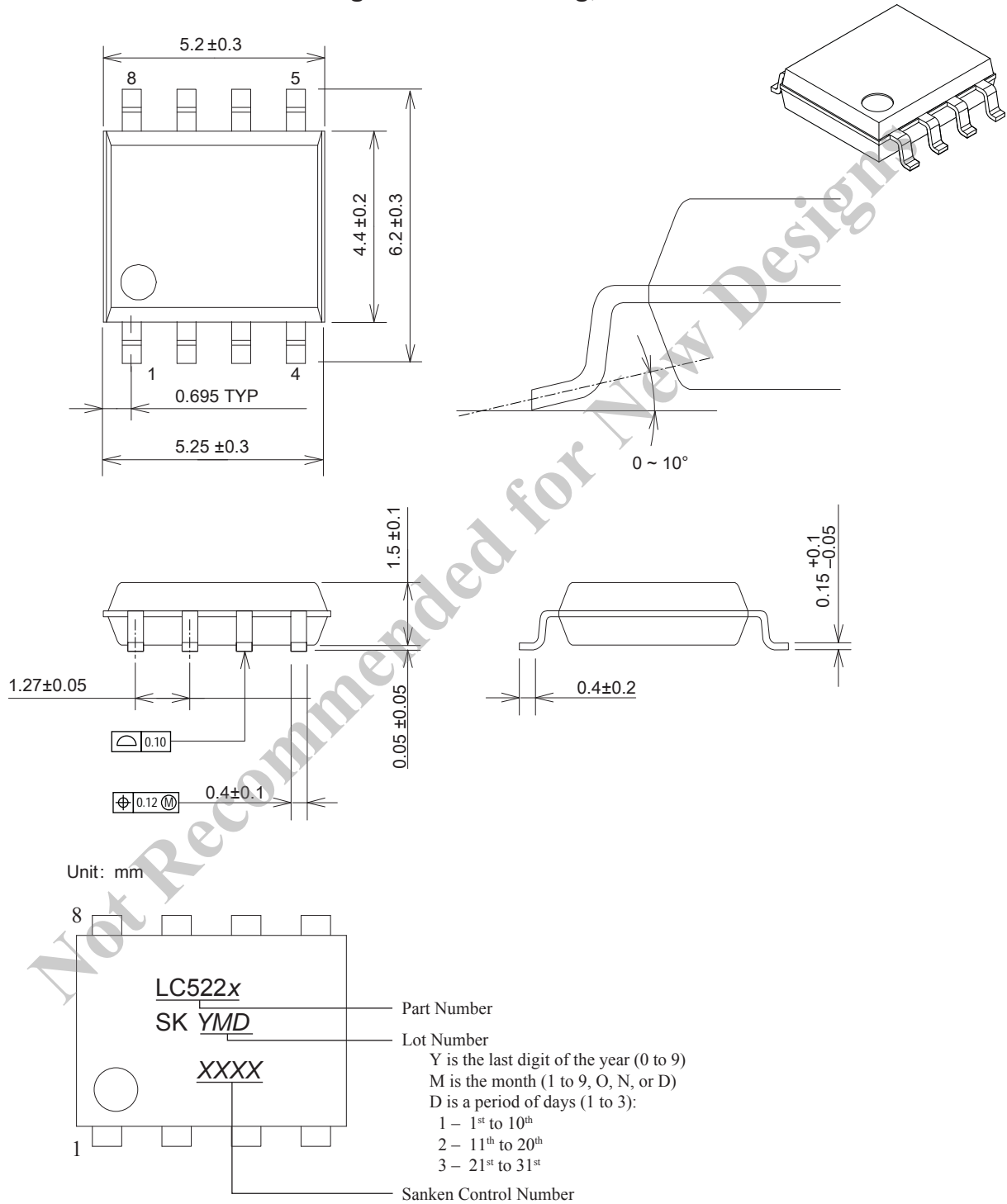

Pb-free. Device composition compliant with the RoHS directive.

Because reliability can be affected adversely by improper storage environments and handling methods, please observe the following cautions.

Cautions for Storage

- Ensure that storage conditions comply with the standard temperature (5°C to 35°C) and the standard relative humidity (around 40% to 75%); avoid storage locations that experience extreme changes in temperature or humidity.
- Avoid locations where dust or harmful gases are present and avoid direct sunlight.
- Reinspect for rust on leads and solderability of the products that have been stored for a long time.

Cautions for Testing and Handling

When tests are carried out during inspection testing and other standard test periods, protect the products from power surges from the testing device, shorts between the product pins, and wrong connections. Ensure all test parameters are within the ratings specified by Sanken for the products.

Remarks About Using Silicone Grease with a Heatsink

- When silicone grease is used in mounting the products on a heatsink, it shall be applied evenly and thinly. If more silicone grease than required is applied, it may produce excess stress.
- Volatile-type silicone greases may crack after long periods of time, resulting in reduced heat radiation effect. Silicone greases with low consistency (hard grease) may cause cracks in the mold resin when screwing the products to a heatsink.

Our recommended silicone greases for heat radiation purposes, which will not cause any adverse effect on the product life, are indicated below:

Type	Suppliers
G746	Shin-Etsu Chemical Co., Ltd.
YG6260	Momentive Performance Materials Inc.
SC102	Dow Corning Toray Co., Ltd.

Soldering

- When soldering the products, please be sure to minimize the working time, within the following limits:
 - DIP8
 - Flow soldering: 260±5°C 10±1 s (2 times)
 - Soldering iron: 380±10°C 3.5±0.5 s (1 time)
 - Soldering should be at a distance of at least 1.5 mm from the body of the products.
 - SOP8:
 - Reflow soldering: 180°C 90±30 s for preheating, 250°C 10±1 s (260°C peak, 2 times) for solder heating
 - Soldering iron: 380±10°C 3.5±0.5 s (1 time)
 - Note: Flow soldering must not be used.

Electrostatic Discharge

- When handling the products, the operator must be grounded. Grounded wrist straps worn should have at least 1 MΩ of resistance from the operator to ground to prevent shock hazard, and it should be placed near the operator.
- Workbenches where the products are handled should be grounded and be provided with conductive table and floor mats.
- When using measuring equipment such as a curve tracer, the equipment should be grounded.
- When soldering the products, the head of soldering irons or the solder bath must be grounded in order to prevent leak voltages generated by them from being applied to the products.
- The products should always be stored and transported in Sanken shipping containers or conductive containers, or be wrapped in aluminum foil.

-
- The contents in this document are subject to changes, for improvement and other purposes, without notice. Make sure that this is the latest revision of the document before use.
 - Application and operation examples described in this document are quoted for the sole purpose of reference for the use of the products herein and Sanken can assume no responsibility for any infringement of industrial property rights, intellectual property rights or any other rights of Sanken or any third party which may result from its use.
 - Although Sanken undertakes to enhance the quality and reliability of its products, the occurrence of failure and defect of semiconductor products at a certain rate is inevitable. Users of Sanken products are requested to take, at their own risk, preventative measures including safety design of the equipment or systems against any possible injury, death, fires or damages to the society due to device failure or malfunction.
 - Sanken products listed in this document are designed and intended for the use as components in general purpose electronic equipment or apparatus (home appliances, office equipment, telecommunication equipment, measuring equipment, etc.).

When considering the use of Sanken products in the applications where higher reliability is required (transportation equipment and its control systems, traffic signal control systems or equipment, fire/crime alarm systems, various safety devices, etc.), and whenever long life expectancy is required even in general purpose electronic equipment or apparatus, please contact your nearest Sanken sales representative to discuss, prior to the use of the products herein.

The use of Sanken products without the written consent of Sanken in the applications where extremely high reliability is required (aerospace equipment, nuclear power control systems, life support systems, etc.) is strictly prohibited.

- In the case that you use Sanken products or design your products by using Sanken products, the reliability largely depends on the degree of derating to be made to the rated values. Derating may be interpreted as a case that an operation range is set by derating the load from each rated value or surge voltage or noise is considered for derating in order to assure or improve the reliability. In general, derating factors include electric stresses such as electric voltage, electric current, electric power etc., environmental stresses such as ambient temperature, humidity etc. and thermal stress caused due to self-heating of semiconductor products. For these stresses, instantaneous values, maximum values and minimum values must be taken into consideration.

In addition, it should be noted that since power devices or IC's including power devices have large self-heating value, the degree of derating of junction temperature affects the reliability significantly.

- When using the products specified herein by either (i) combining other products or materials therewith or (ii) physically, chemically or otherwise processing or treating the products, please duly consider all possible risks that may result from all such uses in advance and proceed therewith at your own responsibility.
- Anti radioactive ray design is not considered for the products listed herein.
- Sanken assumes no responsibility for any troubles, such as dropping products caused during transportation out of Sanken's distribution network.
- The contents in this document must not be transcribed or copied without Sanken's written consent.