

◆ **Description**

LC5226D is non-isolated type driver IC for LED lighting which can achieve high efficiency in simple circuitry. Its compact package which includes output MOSFET and controller, and low external components are suitable for small lighting equipment which requires saving space, like LED light bulb.

To meet various requirements, Buck-Boost operation which has wide input/output capability is available. And also, control functions with Ref input are implemented.

Its high voltage capability allows direct connection to rectified AC supply.

Open protection for Buck-Boost operation and variable OCP improve safeness.

◆ **Applications**

- LED Lighting equipment
- LED Light bulb

◆ **Features**

- Buck-Boost operation
 In addition to normal Buck operation, Buck-Boost operation which can both Step-up and down is also available, to operate in wide input/output condition.
- Open protection for Buck-Boost operation
 Protection circuit to prevent damage when load open failure in Buck-Boost operation.
- Built-in reference voltage for current setting
 Precision and easy current setting.
- Sleep function
 Latch off the output by Ref pin input voltage.
- Disable function
 Shut off LED current by Ref pin input voltage.

◆ **Package**

Package: DIP8

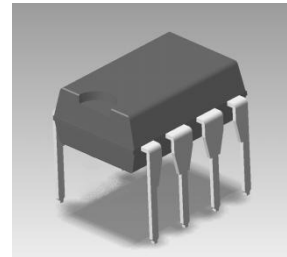

◆ **Main Specification**

MOSFET	450V (MIN), 3.0Ω (MAX)
Output Current	1.0A (MAX)
Main Supply Voltage	450V (MAX)

- DIP8 Package
 Output MOSFET and controller are included in one package.
- High voltage supply input
- Built-in constant current controller
 - PWM mode current control circuitry.
 - Adjustable output current by input voltage to Ref pin.
- External PWM Dimming
- Variable type over current protection (OCP)
 - Latch type operation
 - OCP threshold is adjusted by setting current and temperature to ensure protection.
- Under voltage lockout protection (UVLO)
- Thermal Shutdown protection (TSD)

Typical application circuit

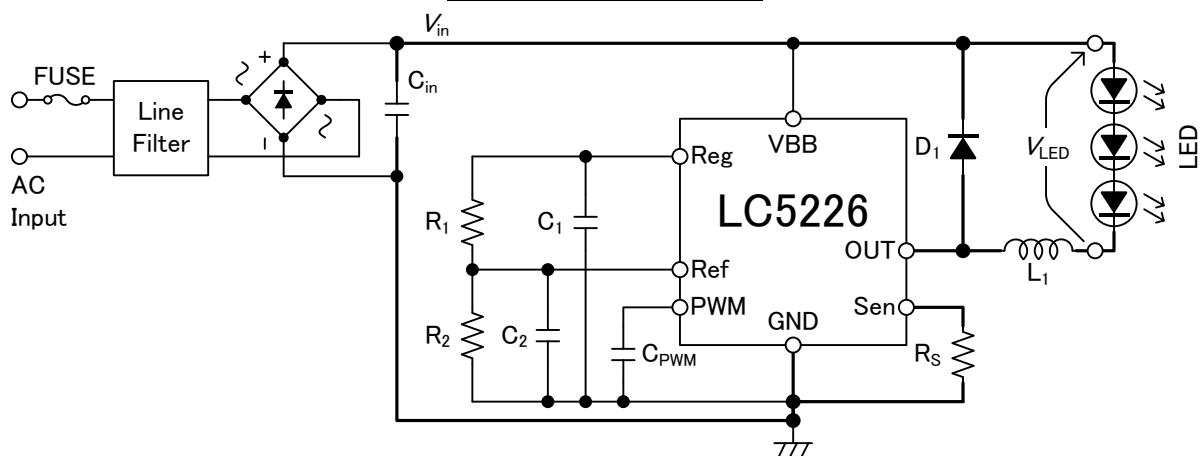

1 Scope

The present specifications shall apply to a LED driver IC for LED lighting, LC5226D.

2 Outline

Type	Hybrid Integrated Circuit
Structure	Plastic Molded (Transfer Mold)
Applications	LED Lighting

3 Absolute Maximum Ratings (Ta=25°C)

Parameter	Terminal	Symbol	Ratings	Units	Remarks
Main Power Supply Voltage	6-8	V _{BB}	450	V	
Output Breakdown Voltage	5-4	V _O	450	V	
Output Current	5-4	I _O	1.0 ^{*1}	A	Exclude Pulse Width<1μs
PWM Pin Voltage	2-8	V _{PWM}	-0.3~V _Z ^{*2}	V	
Ref Pin Voltage	3-8	V _{Ref}	-0.3~V _Z ^{*2}	V	
Sen Pin Voltage	4-8	V _{Sen}	-0.3~4.0	V	Exclude Pulse Width<1μs
Allowable Power Dissipation	—	P _D	1.73 ^{*3}	W	Mounted on PWB ^{*4}
Junction Temperature	—	T _j	150	°C	
Operating Temperature Range	—	T _a	-40~105	°C	
Storage Temperature Range	—	T _{stg}	-40~150	°C	

※1 Output current rating may be limited by duty cycle, ambient temperature, and heat sinking.
 Under any set of conditions, do not exceed the specified junction temperature (T_j).

※2 V_Z here is breakdown voltage of zener diode which is internally connected to between pins and GND. (V_Z=6.3V typ.) Maximum input current is 1mA.

※3 Allowable Power Dissipation depends on PWB pattern layout.

※4 Mounted on SanKen evaluation board.

4 Electrical Characteristic (Ta=25°C, V_{BB}=140V, Unless Otherwise Noted.)

Parameter	Terminal	Symbol	Ratings			Units	Remarks
			MIN	TYP	MAX		
Power Supply Current	6-8	I _{BBs}	—	1	1.5	mA	At disable
	6-8	I _{BB}	—	2.5	4.0	mA	At enable
Output MOSFET Breakdown Voltage	5-4	V _{(BR)DSS}	450	—	—	V	I _D =1mA
Output MOSFET On Resistance	5-4	R _{DS(on)}	—	1.7	3.0	Ω	I _D =1.0A
Body Diode Forward Voltage	4-5	V _F	—	0.88	1.0	V	I _F =1.0A
UVLO Threshold (Turn On)	6-8	V _{UVLO(on)}	—	14	—	V	
UVLO Threshold (Turn Off)	6-8	V _{UVLO(off)}	—	12	—	V	
Reg Output Voltage	1-8	V _{Reg}	9.6	10	10.4	V	I _{Reg} =0mA
Reg Output Current	1-8	I _{Reg}	—	—	-2	mA	V _{Reg} =9V
Enable Voltage	3-8	V _{ENB}	—	0.15	0.19	V	
Sleep Voltage	3-8	V _{SLP}	2.85	3.0	—	V	
Ref Pin Input Current	3-8	I _{Ref}	-10	—	10	μA	
Current Control Detection Voltage	4-8	V _{Sen}	0.4V _{Ref} -0.03	0.4V _{Ref}	0.4V _{Ref} +0.03	V	V _{Ref} =0.2~2.0V
			0.77	0.8	0.83	V	V _{Ref} =2.0~3.0V
OCP Detection Voltage	4-8	V _{OCP}	—	0.4V _{Ref} +0.7	—	V	V _{Ref} =0.2~2.0V
			—	1.5	—	V	V _{Ref} =2.0~3.0V
Sen Pin Input Current	4-8	I _{Sen}	-10	—	10	μA	
PWM Pin Low Voltage	2-8	V _{PWML}	—	2	—	V	
PWM Pin High Voltage	2-8	V _{PWMH}	—	3	—	V	
PWM Pin Output Current	2-8	I _{PWM}	—	-20	—	μA	
PWM Blanking Time	—	t _{BLKP}	—	0.3	—	μs	
OCP Blanking Time	—	t _{BLKO}	—	0.2	—	μs	
PWM Frequency	2-8	f _{PWM}	—	—	200※5	kHz	Duty=50%
PWM Off Time	—	t _{Off}	—	17	—	μs	C _{PWM} =100pF
Rise Time	5-4	t _r	—	25	—	ns	I _o =0.4A
Fall Time	5-4	t _f	—	50	—	ns	I _o =0.4A
Thermal Shutdown Threshold	—	T _{TSD}	—	150	—	°C	Temperature of Control IC
Thermal Shutdown Hysteresis	—	T _{TSDhys}	—	55	—	°C	

※5 Operation at a PWM frequency greater than f_{PWM} is possible but not warranted.

Thermal Data

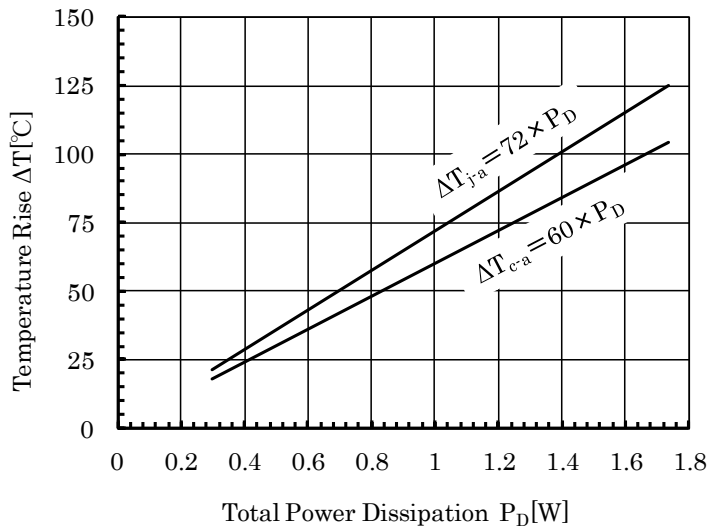

Power Dissipation versus Ambient Temperature

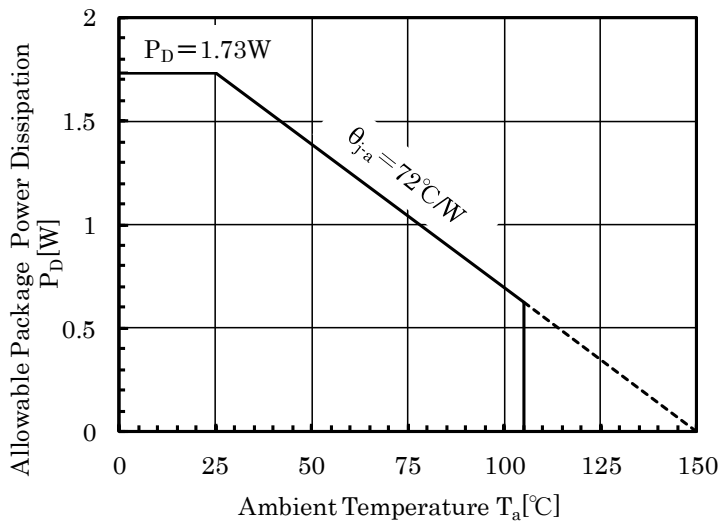

5 Functional Block Diagram (Pin assignment)

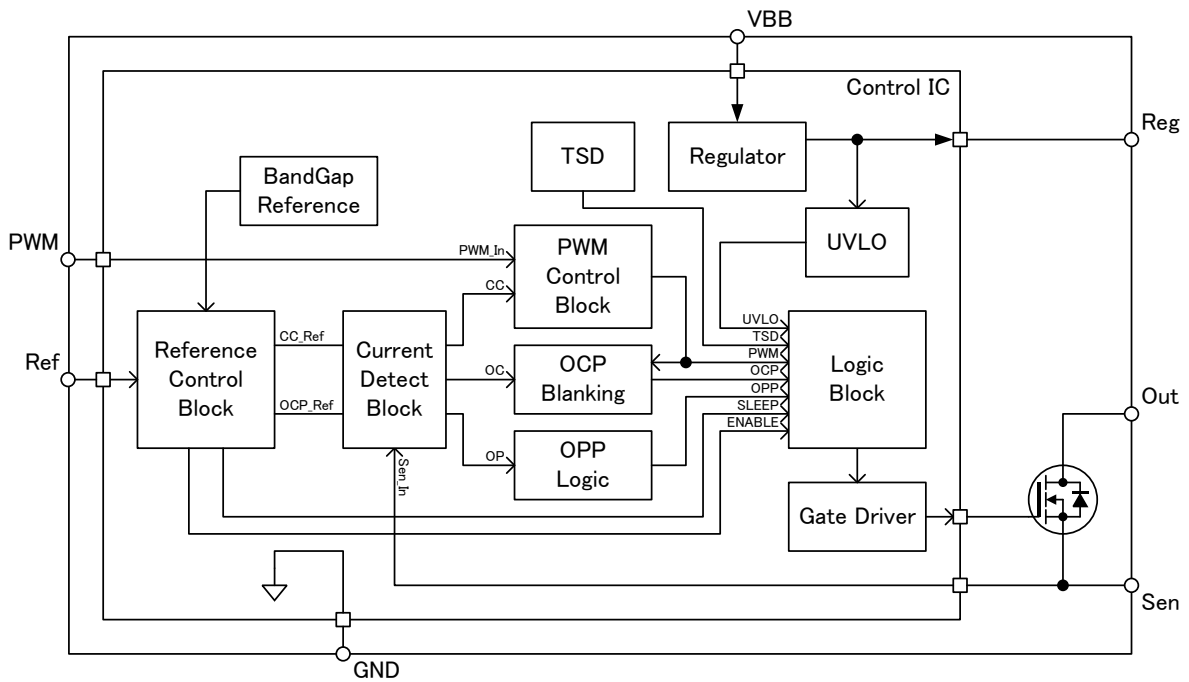

Pin Assignment

Number	Name	Function
1	Reg	Output of 10V Internal Regulator
2	PWM	PWM Control
3	Ref	Setting Output Current and Operation
4	Sen	Current Sensing
5	OUT	Output (Power MOSFET Drain)
6	VBB	Power Supply
7	—	Pin Removed
8	GND	Ground

6 Package

6.1 Package Drawing and Material

- DIP8 Package

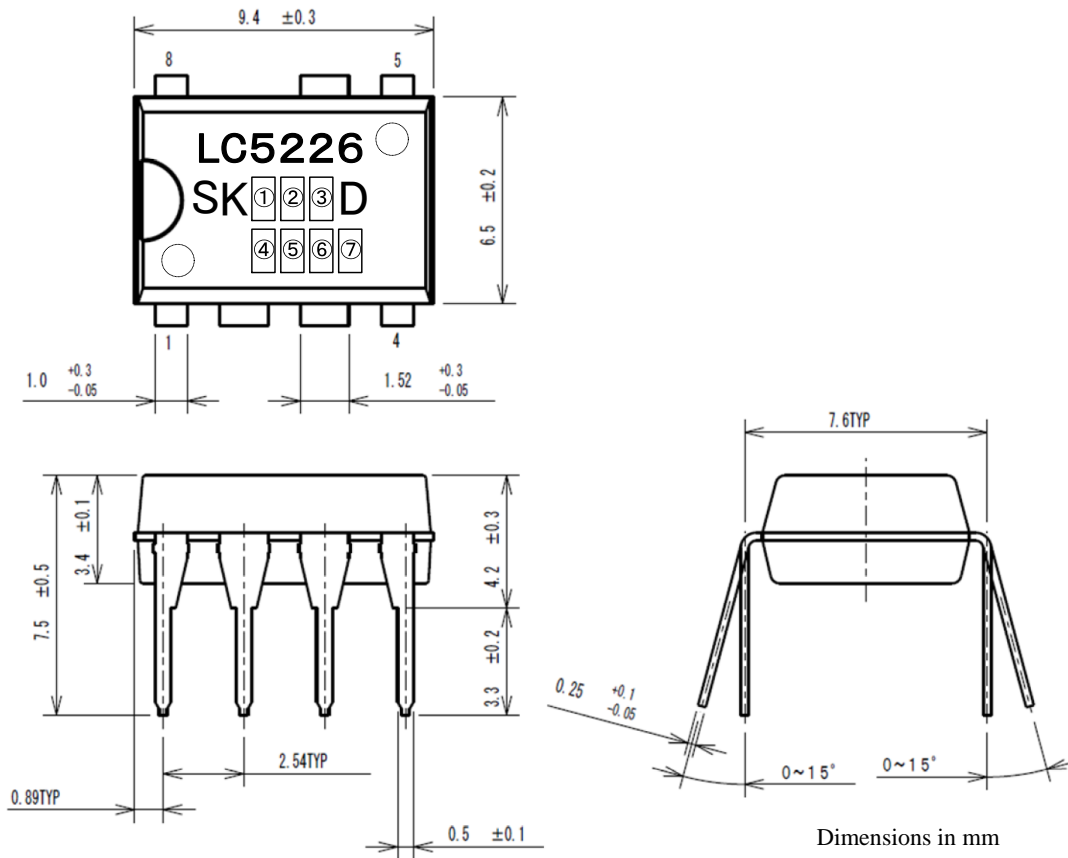

Terminal material: Cu

Terminal treatment:
 Solder plating (Pb-free)

Marking

Position	Contents	Indication
①	The last digit of the year	0 to 9
②	The Month	1 to 9, O, N, D
③	The week	1 to 3
④	SanKen Registration Number	alphanumeric characters
⑤		
⑥		
⑦		

6.2 Appearance

The body shall be clean and shall not bear any stain, rust or flaw.

6.3 Marking

The type number and lot number shall be clearly marked by laser so that cannot be erased easily.

7 Cautions and warnings

Since reliability can be affected adversely by improper storage environment and handling methods during Characteristic tests, please observe the following cautions.

7.1 Cautions for Storage

- Ensure that storage conditions comply with the standard temperature (5 to 35°C) and the standard relative humidity (around 40 to 75%) and avoid storage locations that experience extreme changes in temperature or humidity.
- Avoid locations where dust or harmful gases are present and avoid direct sunlight.
- Reinspect for rust in leads and solderability that have been stored for a long time.

7.2 Cautions for characteristic Tests and Handling

- When characteristic tests are carried out during inspection testing and other standard tests periods, protect the devices from surge of power from the testing device, shorts between the devices and the heatsink.

7.3 Considerations to protect the Products from Electrostatic Discharge

- When handling the devices, operator must be grounded. Grounded wrist straps be worn and should have at least 1MΩ of resistance near operators to ground to prevent shock hazard.
- Workbenches where the devices are handled should be grounded and be provided with conductive table and floor mats.
- When using measuring equipment such as a curve tracer, the equipment should also be grounded.
- When soldering the devices, the head of a soldering iron or a solder bath must be grounded in order to prevent leak voltage generated by them from being applied to the devices.
- The devices should always be stored and transported in our shipping containers or conductive containers, or be wrapped up in aluminum foil.

7.4 Others

- The contents in this document are subject to changes, for improvement and other purposes, without notice. Make sure that this is the latest revision of the document before use.
- Application and operation examples described in this document are quoted for the sole purpose of reference for the use of the products herein and SanKen can assume no responsibility for any infringement of industrial property rights, intellectual property rights or any other rights of SanKen or any third party which may result from its use.
- Although SanKen undertakes to enhance the quality and reliability of its products, the occurrence of failure and defect of semiconductor products at a certain rate is inevitable. Users of SanKen products are requested to take, at their own risk, preventative measures including safety design of the equipment or systems against any possible injury, death, fires or damages to the society due to device failure or malfunction.
- SanKen products listed in this document are designed and intended for the use as components in general purpose electronic equipment or apparatus (home appliances, office equipment, telecommunication equipment, measuring equipment, etc.).

When considering the use of SanKen products in the applications where higher reliability is required (transportation equipment and its control systems, traffic signal control systems or equipment, fire/crime alarm systems, various safety devices, etc.), and whenever long life expectancy is required even in general purpose electronic equipment or apparatus, please contact your nearest SanKen sales representative to discuss, prior to the use of the products herein.

The use of SanKen products without the written consent of SanKen in the applications where extremely high reliability is required (aerospace equipment, nuclear power control systems, life support systems, etc.) is strictly prohibited.

- In the case that you use our semiconductor devices or design your products by using our semiconductor devices, the reliability largely depends on the degree of derating to be made to the rated values. Derating may be interpreted as a case that an operation range is set by derating the load from each rated value or surge voltage or noise is considered for derating in order to assure or improve the reliability. In general, derating factors include electric stresses such as electric voltage, electric current, electric power etc., environmental stresses such as ambient temperature, humidity etc. and thermal stress caused due to self-heating of semiconductor devices. For these stresses, instantaneous values, maximum values and minimum values must be taken into consideration.
In addition, it should be noted that since power devices or IC's including power devices have large self-heating value, the degree of derating of junction temperature (T_j) affects the reliability significantly.
- When using the products specified herein by either (i) combining other products or materials therewith or (ii) physically, chemically or otherwise processing or treating the products, please duly consider all possible risks that may result from all such uses in advance and proceed therewith at your own responsibility.
- Anti radioactive ray design is not considered for the products listed herein.
- SanKen assumes no responsibility for any troubles, such as dropping products caused during transportation out of SanKen's distribution network.
- The contents in this document must not be transcribed or copied without SanKen's written consent.