

LCM ENGINEERING SPECIFICATION

*MODEL	LC550EUF
SUFFIX	PEF1
Update	Aug. 09, 2012

- () Preliminary Specification
(●) Final Specification

Product Specification

CONTENTS

Number	ITEM	Page
	COVER	1
	CONTENTS	2
	RECORD OF REVISIONS	3
1	GENERAL DESCRIPTION	4
2	ABSOLUTE MAXIMUM RATINGS	5
3	ELECTRICAL SPECIFICATIONS	6
3-1	ELECTRICAL CHARACTERISTICS	6
3-2	INTERFACE CONNECTIONS	8
3-3	SIGNAL TIMING SPECIFICATIONS	11
3-4	LVDS SIGNAL SPECIFICATIONS	12
3-5	COLOR DATA REFERENCE	15
3-6	POWER SEQUENCE	16
4	OPTICAL SPECIFICATIONS	17
5	MECHANICAL CHARACTERISTICS	23
6	RELIABILITY	26
7	INTERNATIONAL STANDARDS	27
7-1	SAFETY	27
7-2	EMC	27
7-3	ENVIRONMENT	27
8	PACKING	28
8-1	INFORMATION OF LCM LABEL	28
8-2	PACKING FORM	28
9	PRECAUTIONS	29
9-1	MOUNTING PRECAUTIONS	29
9-2	OPERATING PRECAUTIONS	29
9-3	ELECTROSTATIC DISCHARGE CONTROL	30
9-4	PRECAUTIONS FOR STRONG LIGHT EXPOSURE	30
9-5	STORAGE	30
9-6	OPERAGING CONDITION GUIDE	30

1. General Description

The LC550EUF is a Color Active Matrix Liquid Crystal Display with an integral Light Emitting Diode (LED) backlight system. The matrix employs a-Si Thin Film Transistor as the active element. It is a transmissive display type which is operating in the normally black mode. It has a 54.64 inch diagonally measured active display area with WUXGA resolution (1080 vertical by 1920 horizontal pixel array). Each pixel is divided into Red, Green and Blue sub-pixels or dots which are arrayed in vertical stripes. Gray scale or the luminance of the sub-pixel color is determined with a 10-bit gray scale signal for each dot. Therefore, it can present a palette of more than 1.06Billion colors.

It has been designed to apply the 10-bit 4-port LVDS interface.

It is intended to support LCD TV, PCTV where high brightness, super wide viewing angle, high color gamut, high color depth and fast response time are important.

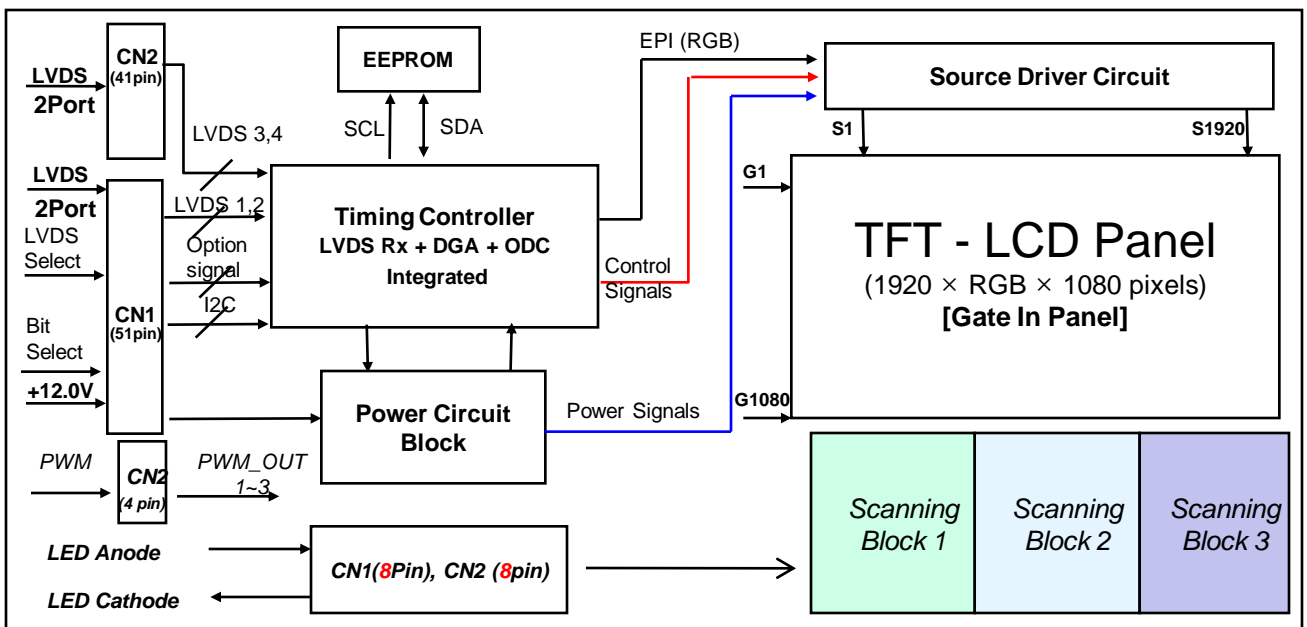

General Features

Active Screen Size	54.64 inches(1387.80mm)diagonal
Outline Dimension	1229.4(H) X 711.8(V) X 9.6(B) X 20.7(D)
Pixel Pitch	0.630mm x 0.630 mm
Pixel Format	1920 horiz. by 1080 vert. Pixels, RGB stripe arrangement
Color Depth	10bit(D), 1.06Billion colors
Luminance, White	400 cd/m ² (Center 1point ,Typ.)
Viewing Angle (CR>10)	Viewing angle free (R/L 178 (Min.), U/D 178 (Min.))
Power Consumption	Total 107.7W (Typ.) (Logic=9.4Wwith T-CON, LED Backlight =98.3W)(TBD)
Weight	15.4 Kg (Typ.)
Display Mode	Transmissive mode, Normally black
Surface Treatment	Hard coating(2H), Anti-glare treatment of the front polarizer (Haze < 1%)

2. Absolute Maximum Ratings

The following items are maximum values which, if exceeded, may cause faulty operation or permanent damage to the LCD module.

Table 1. ABSOLUTE MAXIMUM RATINGS

Parameter		Symbol	Value		Unit	Note
			Min	Max		
Power Input Voltage	LCD Circuit	V _{LCD}	-0.3	+14.0	V _{DC}	1
LED Input Voltage	Forward Voltage	V _F	-	+73.9	V _{DC}	
T-Con Option Selection Voltage		V _{LOGIC}	-0.3	+4.0	V _{DC}	
Operating Temperature		T _{OP}	0	+50	°C	2,3
Storage Temperature		T _{ST}	-20	+65	°C	
Panel Front Temperature		T _{SUR}	-	+68	°C	4
Operating Ambient Humidity		H _{OP}	10	90	%RH	2,3
Storage Humidity		H _{ST}	10	90	%RH	

Note1. Ambient temperature condition ($T_a = 25 \pm 2 \text{ }^\circ\text{C}$)

2. Temperature and relative humidity range are shown in the figure below.

Wet bulb temperature should be Max 39°C, and no condensation of water.

3. Gravity mura can be guaranteed below 40°C condition.

4. The maximum operating temperatures is based on the test condition that the surface temperature of display area is less than or equal to 68°C with LCD module alone in a temperature controlled chamber. Thermal management should be considered in final product design to prevent the surface temperature of display area from being over 68°C. The range of operating temperature may be degraded in case of improper thermal management in final product design.

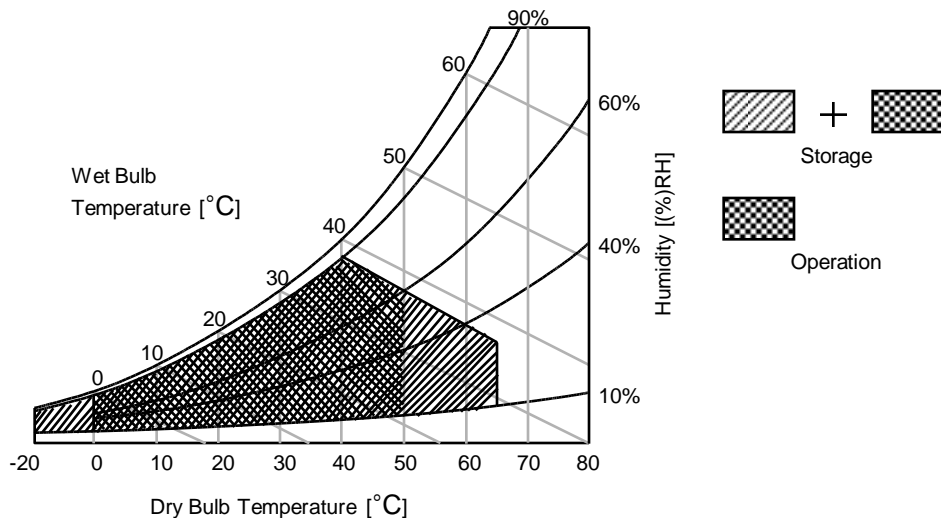

3. Electrical Specifications

3-1. Electrical Characteristics

It requires two power inputs. One is employed to power for the LCD circuit. The other is used for the LED backlight.

Table 2. ELECTRICAL CHARACTERISTICS

Parameter	Symbol	Value			Unit	Note
		Min	Typ	Max		
Circuit :						
Power Input Voltage	V _{LCD}	10.8	12.0	13.2	V _{DC}	
Power Input Current	I _{LCD}	-	784	1019	mA	1
		-	TBD	TBD	mA	2
Power Consumption	P _{LCD}	-	9.4	12.23	Watt	1
Rush current	I _{RUSH}	-	-	TBD	A	3

Note 1. The specified current and power consumption are under the $V_{LCD}=12.0V$, $T_a=25 \pm 2^\circ C$, $f_v=120Hz$ condition, and mosaic pattern(8 x 6) is displayed and f_v is the frame frequency.

2. The current is specified at the maximum current pattern.
3. The duration of rush current is about 2ms and rising time of power input is 0.5ms (min.).
4. Ripple voltage level is recommended under $\pm 5\%$ of typical voltage

White : 1023 Gray

Black : 0 Gray

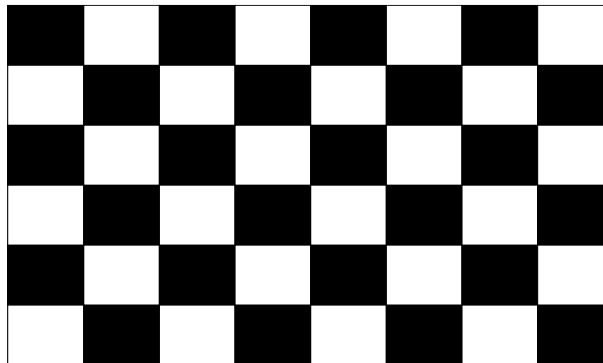

Mosaic Pattern(8 x 6)

Product Specification

Table 3. ELECTRICAL CHARACTERISTICS (Continue)

Parameter		Symbol	Values			Unit	Note
			Min	Typ	Max		
Backlight Assembly :							
Forward Current (one array)	Anode	$I_{F (anode)}$		630		mAdc	±5%
	Cathode	$I_{F (cathode)}$	99.75	105	110.25	mAdc	2, 3
Forward Voltage		V_F	70.8	78.0	84.9	Vdc	4
Forward Voltage Variation		ΔV_F			1.7	Vdc	5
Power Consumption		P_{BL}	-	98.3	107.4	W	6
Burst Dimming Duty		On duty	1		100	%	
Burst Dimming Frequency		1/T	95		182	Hz	8
LED Array							
Life Time			-	-		Hrs	7

- Notes : The design of the LED driver must have specifications for the LED array in LCD Assembly.
 The electrical characteristics of LED driver are based on Constant Current driving type.
 The performance of the LED in LCM, for example life time or brightness, is extremely influenced by the characteristics of the LED Driver. So, all the parameters of an LED driver should be carefully designed.
 When you design or order the LED driver, please make sure unwanted lighting caused by the mismatch of the LED and the driver (no lighting, flicker, etc) has never been occurred. When you confirm it, the LCD-Assembly should be operated in the same condition as installed in your instrument.
- Electrical characteristics are based on LED Array specification.
 - Specified values are defined for a Backlight Assembly. (IBL :2 LED array/LCM)
 - Each LED array has one anode terminal and six cathode terminals.
 The forward current(I_F) of the anode terminal is 630mA and it supplies 105mA into six strings, respectively

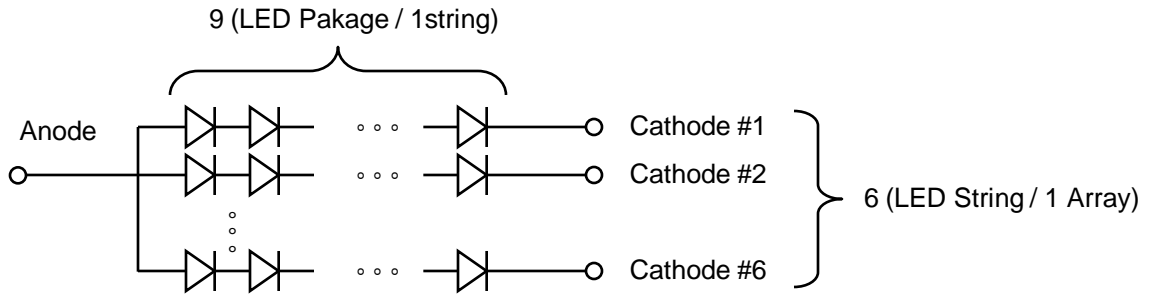

- The forward voltage(V_F) of LED array depends on ambient temperature (Appendix-V)
- ΔV_F means Max V_F -Min V_F in one Backlight. So V_F variation in a Backlight isn't over Max. 1.7V
- Maximum level of power consumption is measured at initial turn on.
 Typical level of power consumption is measured after 1hrs aging at $25 \pm 2^\circ\text{C}$.
- The life time(MTTF) is determined as the time at which brightness of the LED is 50% compared to that of initial value at the typical LED current on condition of continuous operating at $25 \pm 2^\circ\text{C}$, based on duty 100%.
- The reference method of burst dimming duty ratio.
 It is recommended to use synchronous V-sync frequency to prevent waterfall
 ($V_{sync} * 2 = \text{Burst Frequency}$)
 Though PWM frequency is over 182Hz (max252Hz), function of backlight is not affected.

Product Specification

3-2. Interface Connections

This LCD module employs two kinds of interface connection, 51-pin connector and 41-pin connector are used for the module electronics and Two 8-pin connectors are used for the integral backlight system.

3-2-1. LCD Module

- LCD Connector(CN1): FI-RE51S-HF(manufactured by JAE)
- Mating Connector : FI-R51HL(JAE) or compatible

Table 4-1. MODULE CONNECTOR(CN1) PIN CONFIGURATION

No	Symbol	Description	No	Symbol	Description
1	PCID_EN	'H': PCID Enable, 'L' or NC: PCID Disable (3D Mode Only)	27	Bit Select	'H' or NC= 10bit(D) , 'L' = 8bit
2	NC	No Connection (Note 4)	28	R2AN	SECOND LVDS Receiver Signal (A-)
3	NC	No Connection (Note 4)	29	R2AP	SECOND LVDS Receiver Signal (A+)
4	SDA	SDA (For Local Dimming)	30	R2BN	SECOND LVDS Receiver Signal (B-)
5	SCL	SCL (For Local Dimming)	31	R2BP	SECOND LVDS Receiver Signal (B+)
6	NC	No Connection (Note 4)	32	R2CN	SECOND LVDS Receiver Signal (C-)
7	LVDS Select	'H' =JEIDA , 'L' or NC = VESA	33	R2CP	SECOND LVDS Receiver Signal (C+)
8	NC	No Connection (Note 4)	34	GND	Ground
9	NC	No Connection (Note 4)	35	R2CLKN	SECOND LVDS Receiver Clock Signal(-)
10	NC	No Connection (Note 4)	36	R2CLKP	SECOND LVDS Receiver Clock Signal(+)
11	GND	Ground	37	GND	Ground
12	R1AN	FIRST LVDS Receiver Signal (A-)	38	R2DN	SECOND LVDS Receiver Signal (D-)
13	R1AP	FIRST LVDS Receiver Signal (A+)	39	R2DP	SECOND LVDS Receiver Signal (D+)
14	R1BN	FIRST LVDS Receiver Signal (B-)	40	R2EN	SECOND LVDS Receiver Signal (E-)
15	R1BP	FIRST LVDS Receiver Signal (B+)	41	R2EP	SECOND LVDS Receiver Signal (E+)
16	R1CN	FIRST LVDS Receiver Signal (C-)	42	NC or GND	No Connection or Ground
17	R1CP	FIRST LVDS Receiver Signal (C+)	43	NC or GND	No Connection or Ground
18	GND	Ground	44	GND	Ground (Note 6)
19	R1CLKN	FIRST LVDS Receiver Clock Signal(-)	45	GND	Ground
20	R1CLKP	FIRST LVDS Receiver Clock Signal(+)	46	GND	Ground
21	GND	Ground	47	NC	No connection
22	R1DN	FIRST LVDS Receiver Signal (D-)	48	VLCD	Power Supply +12.0V
23	R1DP	FIRST LVDS Receiver Signal (D+)	49	VLCD	Power Supply +12.0V
24	R1EN	FIRST LVDS Receiver Signal (E-)	50	VLCD	Power Supply +12.0V
25	R1EP	FIRST LVDS Receiver Signal (E+)	51	VLCD	Power Supply +12.0V
26	NC or GND	No Connection or Ground	-	-	-

- Note
1. All GND (ground) pins should be connected together to the LCD module's metal frame.
 2. All VLCD (power input) pins should be connected together.
 3. All Input levels of LVDS signals are based on the **EIA 644** Standard.
 4. #2~#3,#6 & #8~#10 NC (No Connection): These pins are used only for LGD (Do not connect)
 5. LVDS pin (pin No. **#24,25,40,41**) are used for 10Bit(D) of the LCD module.
If used for 8Bit(R), these pins are no connection.
 6. Specific pin No. **#44** is used for "No signal detection" of system signal interface.
It should be GND for NSB (No Signal Black) while the system interface signal is not.
If this pin is "H", LCD Module displays AGP (Auto Generation Pattern).
 7. Specific pin (pin No. #4, #5) is used for Controlling Local Dimming register in the LCM Module

Product Specification

- LCD Connector(CN2): FI-RE41S-HF(manufactured by JAE)
- Mating Connector : FI-RE41HL(JAE) or compatible

Table 4-2. MODULE CONNECTOR(CN2) PIN CONFIGURATION

No	Symbol	Description	No	Symbol	Description
1	NC	No connection	22	RE3N	THIRD LVDS Receiver Signal (E-)
2	NC	No connection	23	RE3P	THIRD LVDS Receiver Signal (E+)
3	NC	No connection	24	GND	Ground
4	NC	No connection	25	GND	Ground
5	NC	No connection	26	RA4N	FORTH LVDS Receiver Signal (A-)
6	NC	No connection	27	RA4P	FORTH LVDS Receiver Signal (A+)
7	NC	No connection	28	RB4N	FORTH LVDS Receiver Signal (B-)
8	NC	No connection	29	RB4P	FORTH LVDS Receiver Signal (B+)
9	GND	Ground	30	RC4N	FORTH LVDS Receiver Signal (C-)
10	RA3N	THIRD LVDS Receiver Signal (A-)	31	RC4P	FORTH LVDS Receiver Signal (C+)
11	RA3P	THIRD LVDS Receiver Signal (A+)	32	GND	Ground
12	RB3N	THIRD LVDS Receiver Signal (B-)	33	RCLK4N	FORTH LVDS Receiver Clock Signal(-)
13	RB3P	THIRD LVDS Receiver Signal (B+)	34	RCLK4P	FORTH LVDS Receiver Clock Signal(+)
14	RC3N	THIRD LVDS Receiver Signal (C-)	35	GND	Ground
15	RC3P	THIRD LVDS Receiver Signal (C+)	36	RD4N	FORTH LVDS Receiver Signal (D-)
16	GND	Ground	37	RD4P	FORTH LVDS Receiver Signal (D+)
17	RCLK3N	THIRD LVDS Receiver Clock Signal(-)	38	RE4N	FORTH LVDS Receiver Signal (E-)
18	RCLK3P	THIRD LVDS Receiver Clock Signal(+)	39	RE4P	FORTH LVDS Receiver Signal (E+)
19	GND	Ground	40	GND	Ground
20	RD3N	THIRD LVDS Receiver Signal (D-)	41	GND	Ground
21	RD3P	THIRD LVDS Receiver Signal (D+)	-		

- Note :
1. All GND (ground) pins should be connected together to the LCD module's metal frame.
 2. LVDS pin (**pin No. #22,23,38,39**) are used for 10Bit(D) of the LCD module.
If used for 8Bit(R), these pins are no connection.

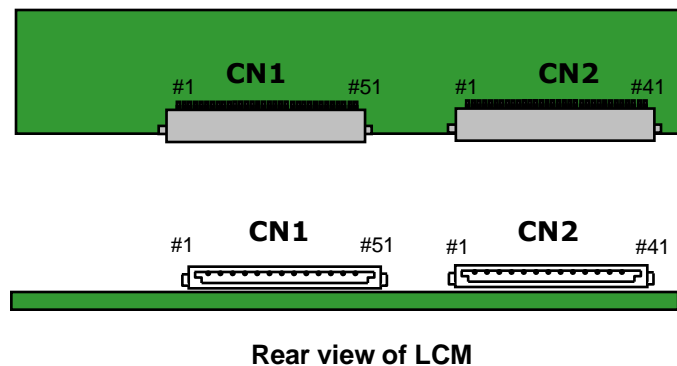

Product Specification

3-2-2. Backlight Module

[CN201]

- 1) LED Array assy Connector (Plug)
: HS100-L08N-N62 (black color, manufactured by UJU)
- 2) Mating Connector (Receptacle)
: IS100-L08T-C46 (black color, manufactured by UJU)

[CN202]

- 1) LED Array assy Connector (Plug)
: HS100-L08N-N62-A (natural color, manufactured by UJU)
- 2) Mating Connector (Receptacle)
: IS100-L08T-C46-A (natural color, manufactured by UJU)

Table 5. BACKLIGHT CONNECTOR PIN CONFIGURATION(CN201,CN202)

No	Symbol	Description	Note
1	L1 Cathode	LED Input Current	
2	L2 Cathode	LED Output Current	
3	L3 Cathode	LED Output Current	
4	L4 Cathode	LED Output Current	
5	L5 Cathode	LED Output Current	
6	L6 Cathode	LED Output Current	
7	N.C	Open	
8	Anode_L	LED Input Current for L1~L6	

No	Symbol	Description	Note
1	Anode_R	LED Input Current for R1~R6	
2	N.C	Open	
3	R6 Cathode	LED Output Current	
4	R5 Cathode	LED Output Current	
5	R4 Cathode	LED Output Current	
6	R3 Cathode	LED Output Current	
7	R2 Cathode	LED Output Current	
8	R1 Cathode	LED Output Current	

◆ Rear view of LCM

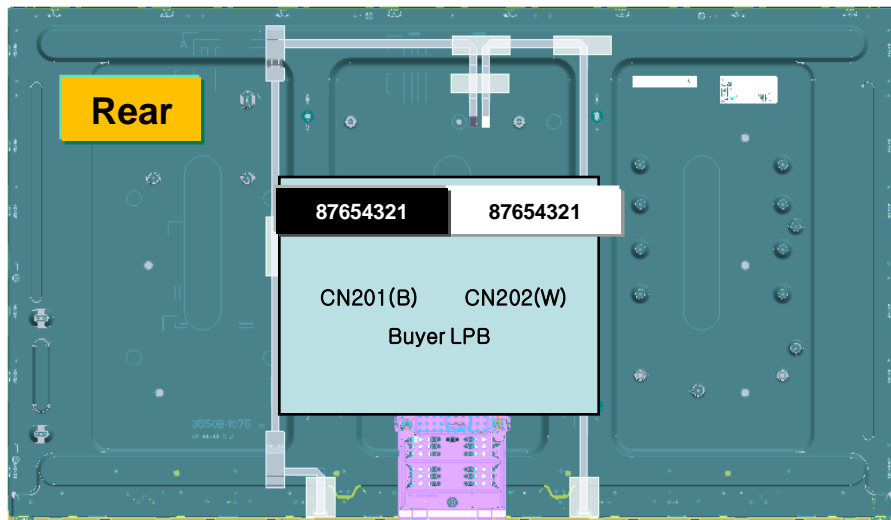

Product Specification

3-3. Signal Timing Specifications

Table 6 shows the signal timing required at the input of the LVDS transmitter. All of the interface signal timings should be satisfied with the following specification for normal operation.

Table 6. TIMING TABLE (DE Only Mode)

ITEM		Symbol	Min	Typ	Max	Unit	Note
Horizontal	Display Period	t _{HV}	480	480	480	tCLK	1920 / 4
	Blank	t _{HB}	40	70	200	tCLK	1
	Total	t _{HP}	520	550	680	tCLK	
Vertical	Display Period	t _{VV}	1080	1080	1080	Lines	
	Blank	t _{VB}	20 (228)	45 (270)	86 (300)	Lines	1
	Total	t _{VP}	1100 (1308)	1125 (1350)	1166 (1380)	Lines	

ITEM		Symbol	Min	Typ	Max	Unit	Note
Frequency	DCLK	f _{CLK}	66.97	74.25	78.00	MHz	
	Horizontal	f _H	121.8	135	140	KHz	2
	Vertical	f _V	108 (95)	120 (100)	122 (104)	Hz	2 NTSC (PAL)

Note: 1. The input of HSYNC & VSYNC signal does not have an effect on normal operation (DE Only Mode).
If you use spread spectrum of EMI, add some additional clock to minimum value for clock margin.

2. The performance of the electro-optical characteristics may be influenced by variance of the vertical refresh rate and the horizontal frequency

※ Timing should be set based on clock frequency.

3-4. LVDS Signal Specification

3-4-1. LVDS Input Signal Timing Diagram

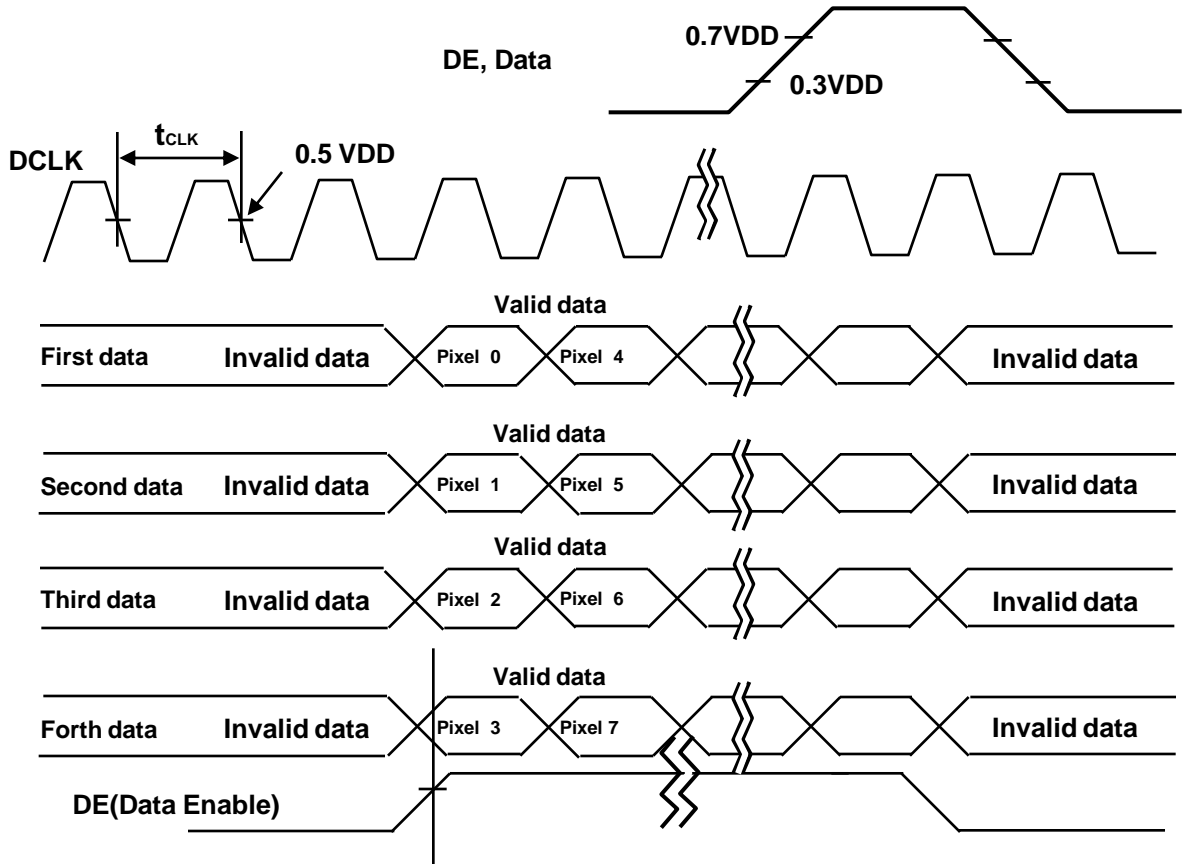

* $t_{HB} = t_{HFP} + t_{WH} + t_{HBP}$

* $t_{VB} = t_{VFP} + t_{VW} + t_{VBP}$

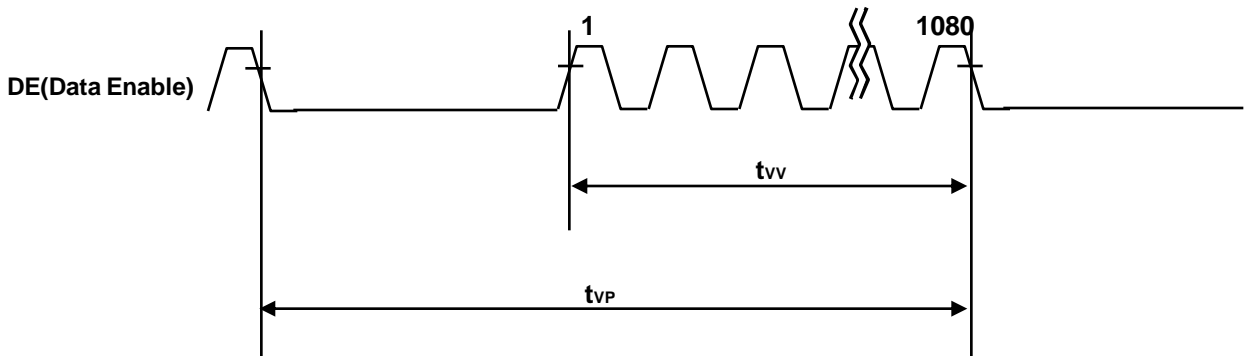

Product Specification

3-4-2. LVDS Input Signal Characteristics

1) DC Specification

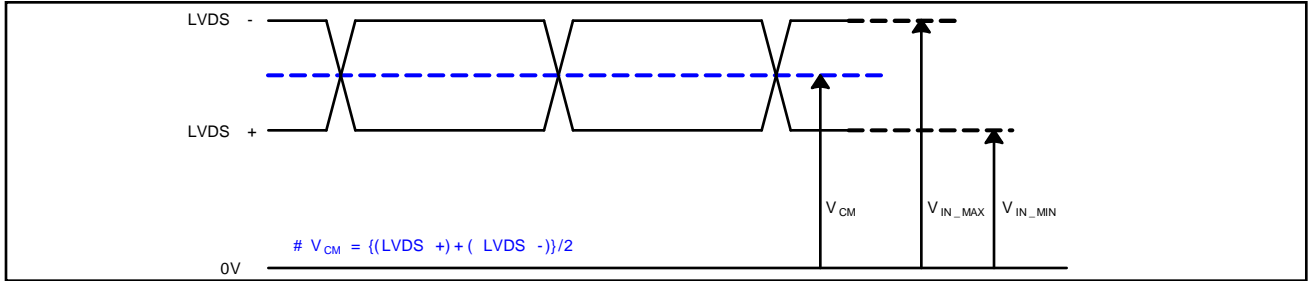

Description	Symbol	Min	Max	Unit	Note
LVDS Common mode Voltage	V_{CM}	1.0	1.5	V	-
LVDS Input Voltage Range	V_{IN}	0.7	1.8	V	-
Change in common mode Voltage	ΔV_{CM}	-	250	mV	-

2) AC Specification

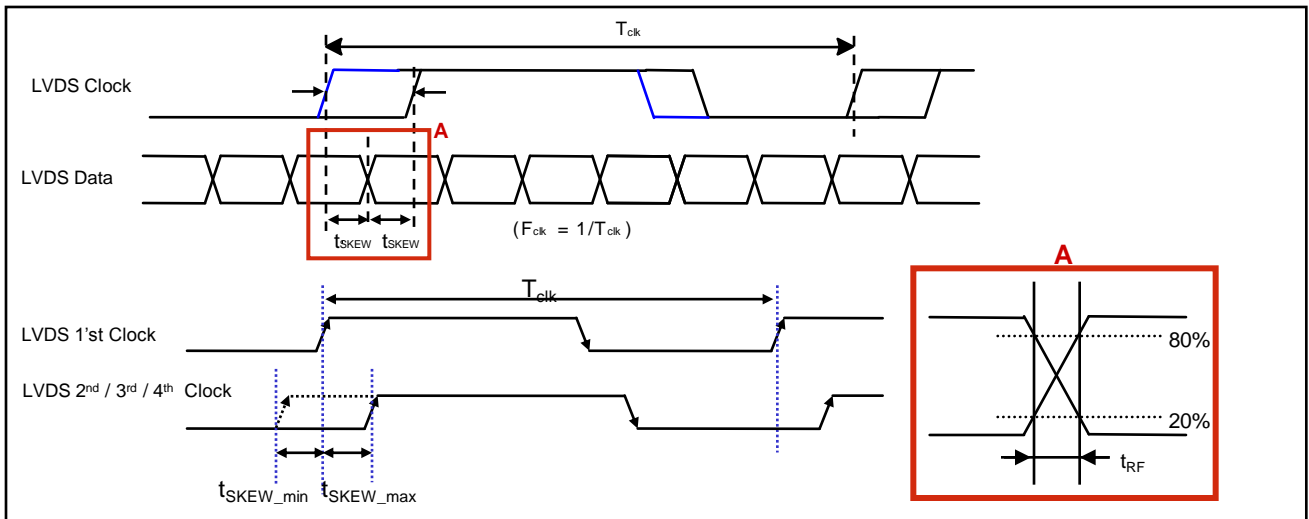

Description	Symbol	Min	Max	Unit	Note
LVDS Differential Voltage	V_{TH}	100	600	mV	Tested with Differential Probe 3
	V_{TL}	-600	-100	mV	
LVDS Clock to Data Skew	t_{SKEW}	-	$ (0.2 * T_{clk})/7 $	ps	-
LVDS Clock/DATA Rising/Falling time	t_{RF}	260	$ (0.3 * T_{clk})/7 $	ps	2
Effective time of LVDS	t_{eff}	$ \pm 360 $	-	ps	-
LVDS Clock to Clock Skew (Even to Odd)	$t_{SKEW_{EO}}$	-	$ 1/7 * T_{clk} $	ps	-

Note 1. All Input levels of LVDS signals are based on the EIA 644 Standard.

2. If t_{RF} isn't enough, t_{eff} should be meet the range.

3. LVDS Differential Voltage is defined within t_{eff}

Product Specification

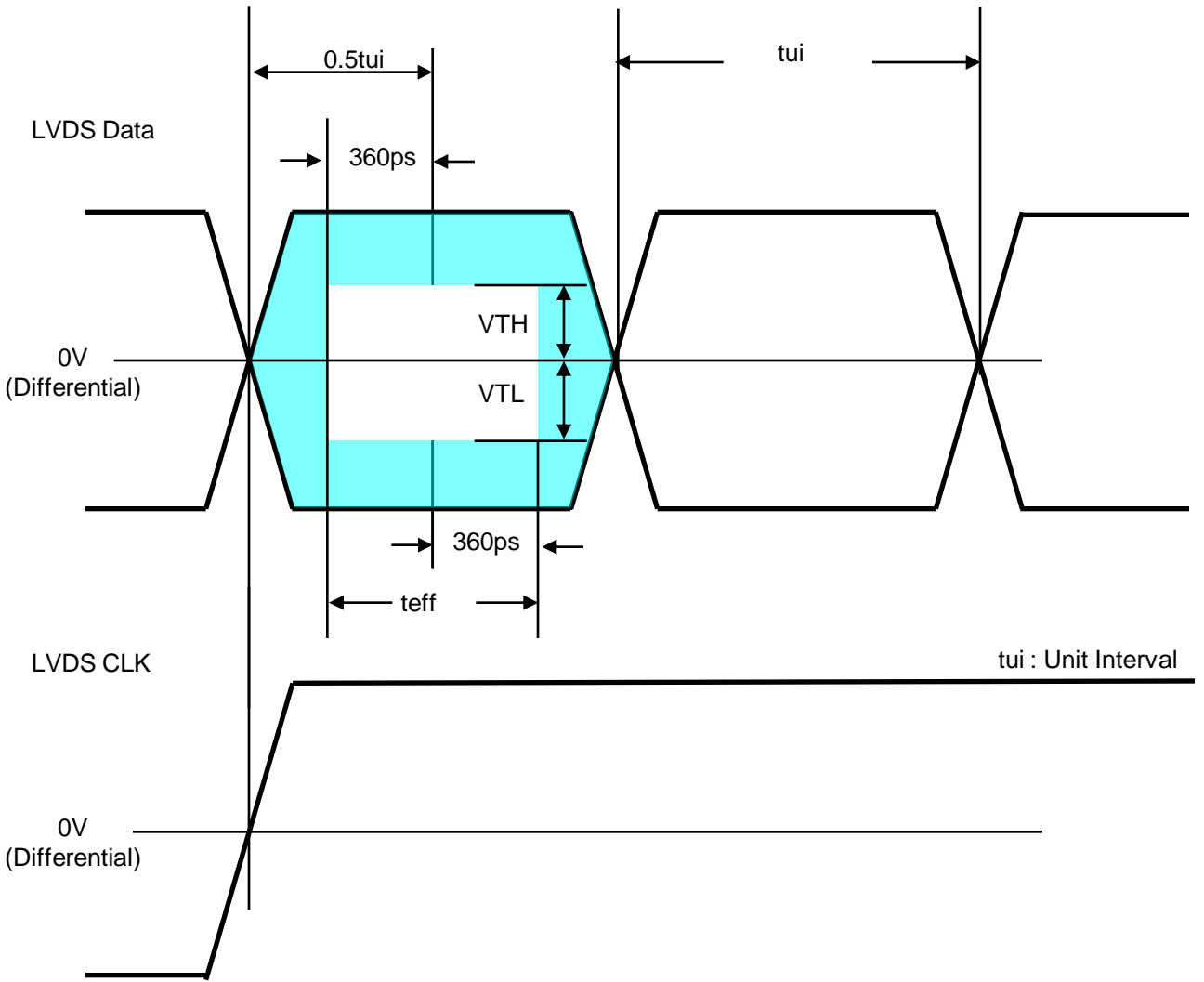

* This accumulated waveform is tested with differential probe

Product Specification

3-5. Color Data Reference

The brightness of each primary color (red, green, blue) is based on the 10bit gray scale data input for the color. The higher binary input, the brighter the color. Table 7 provides a reference for color versus data input.

Table 7. COLOR DATA REFERENCE

Color		Input Color Data																												
		RED										GREEN										BLUE								
		MSB									LSB	MSB									LSB	MSB					LSB			
R9	R8	R7	R6	R5	R4	R3	R2	R1	R0	G9	G8	G7	G6	G5	G4	G3	G2	G1	G0	B9	B8	B7	B6	B5	B4	B3	B2	B1	B0	
Basic Color	Black	0	0	0	0	0	0	0	0	0	0	0	0	0	0	0	0	0	0	0	0	0	0	0	0	0	0	0	0	
	Red (1023)	1	1	1	1	1	1	1	1	1	1	1	1	1	1	1	1	1	1	1	0	0	0	0	0	0	0	0	0	0
	Green (1023)	0	0	0	0	0	0	0	0	0	0	0	0	0	0	0	0	0	0	0	1	1	1	1	1	1	1	1	1	1
	Blue (1023)	0	0	0	0	0	0	0	0	0	0	0	0	0	0	0	0	0	0	0	0	0	0	0	0	0	0	0	0	0
	Cyan	0	0	0	0	0	0	0	0	0	0	0	0	0	0	0	0	0	0	0	1	1	1	1	1	1	1	1	1	1
	Magenta	1	1	1	1	1	1	1	1	1	1	1	1	1	1	1	1	1	1	1	0	0	0	0	0	0	0	0	0	0
	Yellow	1	1	1	1	1	1	1	1	1	1	1	1	1	1	1	1	1	1	1	1	1	1	1	1	1	1	1	1	1
	White	1	1	1	1	1	1	1	1	1	1	1	1	1	1	1	1	1	1	1	1	1	1	1	1	1	1	1	1	1
RED	RED (0000)	0	0	0	0	0	0	0	0	0	0	0	0	0	0	0	0	0	0	0	0	0	0	0	0	0	0	0	0	
	RED (0001)	0	0	0	0	0	0	0	0	0	0	0	0	0	0	0	0	0	0	0	0	0	0	0	0	0	0	0	1	
								
	RED (1022)	1	1	1	1	1	1	1	1	1	1	1	1	1	1	1	1	1	1	1	0	0	0	0	0	0	0	0	0	0
	RED (1023)	1	1	1	1	1	1	1	1	1	1	1	1	1	1	1	1	1	1	1	1	1	1	1	1	1	1	1	1	1
GREEN	GREEN (0000)	0	0	0	0	0	0	0	0	0	0	0	0	0	0	0	0	0	0	0	0	0	0	0	0	0	0	0	0	
	GREEN (0001)	0	0	0	0	0	0	0	0	0	0	0	0	0	0	0	0	0	0	0	0	0	0	0	0	0	0	0	1	
								
	GREEN (1022)	0	0	0	0	0	0	0	0	0	0	0	0	0	0	0	0	0	0	0	1	1	1	1	1	1	1	1	1	0
	GREEN (1023)	0	0	0	0	0	0	0	0	0	0	0	0	0	0	0	0	0	0	0	1	1	1	1	1	1	1	1	1	1
BLUE	BLUE (0000)	0	0	0	0	0	0	0	0	0	0	0	0	0	0	0	0	0	0	0	0	0	0	0	0	0	0	0	0	
	BLUE (0001)	0	0	0	0	0	0	0	0	0	0	0	0	0	0	0	0	0	0	0	0	0	0	0	0	0	0	0	1	
								
	BLUE (1022)	0	0	0	0	0	0	0	0	0	0	0	0	0	0	0	0	0	0	0	1	1	1	1	1	1	1	1	1	0
	BLUE (1023)	0	0	0	0	0	0	0	0	0	0	0	0	0	0	0	0	0	0	0	1	1	1	1	1	1	1	1	1	1

3-6. Power Sequence

3-6-1. LCD Driving circuit

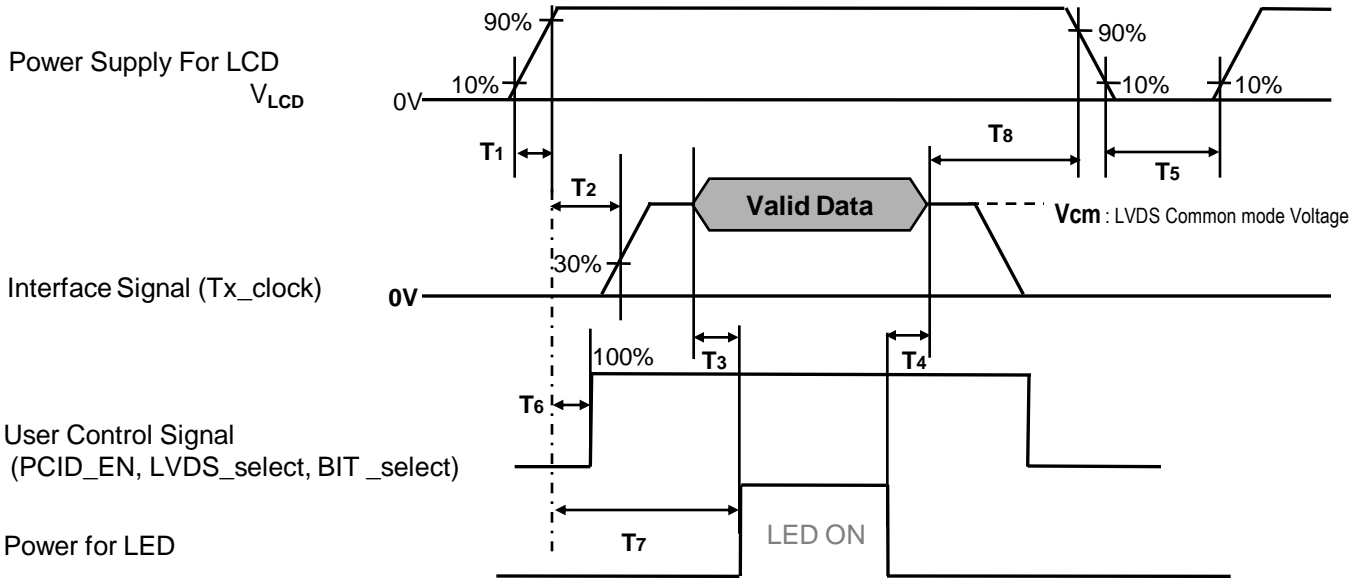
Table 8. POWER SEQUENCE

Parameter	Value			Unit	Notes
	Min	Typ	Max		
T1	0.5	-	20	ms	1
T2	0	-	-	ms	2
T3	200	-	-	ms	3
T4	200	-	-	ms	3
T5	1.0	-	-	s	4
T6	-	-	T2	ms	5
T7	0.5	-	-	s	6
T8	100	-	-	ms	7

- Note :
1. Even though T1 is over the specified value, there is no problem if I2T spec of fuse is satisfied.
 2. If T2 is satisfied with specification after removing LVDS Cable, there is no problem.
 3. The T3 / T4 is recommended value, the case when failed to meet a minimum specification, abnormal display would be shown. There is no reliability problem.
 4. T5 should be measured after the Module has been fully discharged between power off and on period.
 5. If the on time of signals (Interface signal and user control signals) precedes the on time of Power (V_{LCD}), it will be happened abnormal display. When T6 is NC status, T6 doesn't need to be measured.
 6. If there is no abnormal display, no problem.
 7. It is recommendation specification that T8 has to be 100ms as a minimum value.
 - ※ Please avoid floating state of interface signal at invalid period.
 - ※ When the power supply for LCD (V_{LCD}) is off, be sure to pull down the valid and invalid data to 0V.

Product Specification

4. Optical Specification

Optical characteristics are determined after the unit has been 'ON' and stable in a dark environment at $25 \pm 2^\circ\text{C}$. The values are specified at distance 50cm from the LCD surface at a viewing angle of Φ and θ equal to 0° .

FIG. 1 shows additional information concerning the measurement equipment and method.

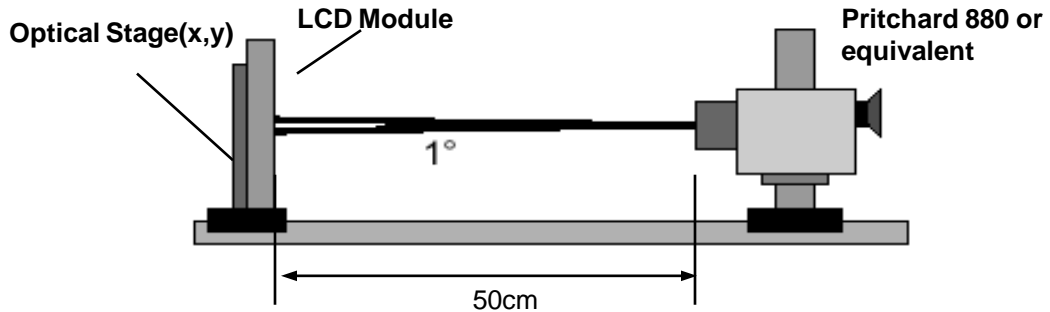

FIG. 1 Optical Characteristic Measurement Equipment and Method

Table 10. OPTICAL CHARACTERISTICS

$T_a = 25 \pm 2^\circ\text{C}$, $V_{LCD} = 12.0\text{V}$, $f_v = 120\text{Hz}$, $D_{clk} = 74.25\text{MHz}$,
Scanning Off. $IF_{cathode} = 105\text{mA}$

Parameter		Symbol	Value			Unit	Note	
			Min	Typ	Max			
Contrast Ratio		CR	1100	1600	-		1	
Surface Luminance, white		L_{WH}	2D	320	400	cd/m ²	2	
			3D	120	150		8	
Luminance Variation		δ_{WHITE}			1.3		3	
Response Time	Gray-to-Gray	G to G	-	5	8	ms	4	
	MPRT	MPRT	-	8	12		5	
	Uniformity	δ_{MPRT}	-	-	1		5	
	Uniformity	$\delta_{G TO G}$	-	-	1		5	
Color Coordinates [CIE1931]		RED	Rx		0.647	Typ +0.03		
			Ry		0.334			
		GREEN	Gx		0.308			
			Gy	Typ -0.03	0.607			
		BLUE	Bx		0.150			
			By		0.066			
WHITE		Wx		0.279				
		Wy		0.292				
Color Temperature				10,000		K		
Color Gamut				72		%		
Viewing Angle	2D (CR>10)	right($\phi=0^\circ$)	θ_r (x axis)	89	-	-	degree	6
		left ($\phi=180^\circ$)	θ_l (x axis)	89	-	-		
		up ($\phi=90^\circ$)	θ_u (y axis)	89	-	-		
		down ($\phi=270^\circ$)	θ_d (y axis)	89	-	-		
	3D (CT \leq 10%)	up + down	θ_u (y axis) + θ_d (y axis)	22	26	-	degree	
		up	θ_u (y axis)	8			degree	8
	down	θ_d (y axis)	8			degree		
3D Crosstalk		3D C/T		1	3	%		
Gray Scale				-	-	-		7

Product Specification

Note : 1. Contrast Ratio(CR) is defined mathematically as :

$$\text{Contrast Ratio} = \frac{\text{Surface Luminance with all white pixels}}{\text{Surface Luminance with all black pixels}}$$

It is measured at center 1-point.

2. Surface luminance is determined after the unit has been 'ON' and 1 Hour after lighting the backlight in a dark environment at $25 \pm 2^\circ\text{C}$. Surface luminance is the luminance value at center 1-point across the LCD surface 50cm from the surface with all pixels displaying white. For more information see the FIG. 2.
3. The variation in surface luminance, δ WHITE is defined as :
 δ WHITE(5P) = Maximum($L_{on1}, L_{on2}, L_{on3}, L_{on4}, L_{on5}$) / Minimum($L_{on1}, L_{on2}, L_{on3}, L_{on4}, L_{on5}$)
 Where L_{on1} to L_{on5} are the luminance with all pixels displaying white at 5 locations .
 For more information, see the FIG. 2.
4. Response time is the time required for the display to transit from G(N) to G(M) (Rise Time, Tr_R) and from G(M) to G(N) (Decay Time, Tr_D). For additional information see the FIG. 3. ($N < M$)
 ※ G to G Spec stands for average value of all measured points.
 Photo Detector : RD-80S / Field : 2°
5. MPRT is defined as the 10% to 90% blur-edge width B_{ij} (pixels) and scroll speed U (pixels/frame) at the moving picture. For more information, see FIG 4
 ※. Gray to Gray / MPRT Response time uniformity is Reference data. **Appendix VIII-1/ VIII-2**
6. Viewing angle is the angle at which the contrast ratio is greater than 10. The angles are determined for the horizontal or x axis and the vertical or y axis with respect to the z axis which is normal to the LCD module surface. For more information, see the FIG. 5.
7. Gray scale specification
 Gamma Value is approximately 2.2. For more information, see the Table 11.
8. 3D performance specification is expressed by 3D luminance, 3D Crosstalk and 3D viewing angle.
 3D luminance and 3D crosstalk is measured at center 1-point.
 For more information, see the FIG 6~9.

Table 11. GRAY SCALE SPECIFICATION

Gray Level	Luminance [%] (Typ)
L0	0.063
L63	0.28
L127	1.05
L191	2.50
L255	4.69
L319	7.67
L383	11.47
L447	16.11
L511	21.64
L575	28.07
L639	35.43
L703	43.73
L767	52.99
L831	63.23
L895	74.47
L959	86.72
L1023	100

Measuring point for surface luminance & measuring point for luminance variation.

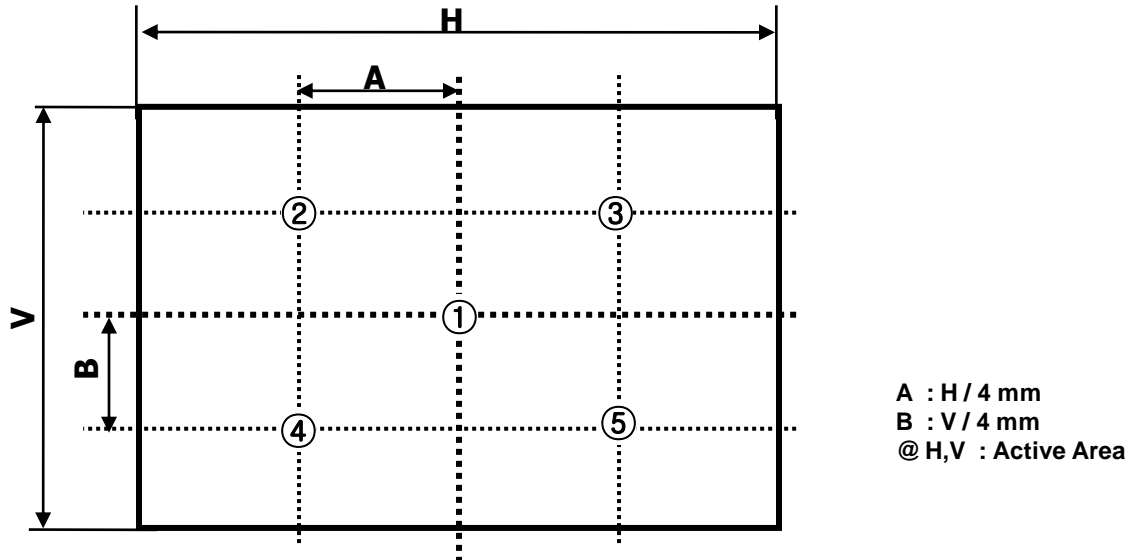

FIG. 2 5 Points for Luminance Measure

Response time is defined as the following figure and shall be measured by switching the input signal for “Gray(N)” and “Gray(M)”.

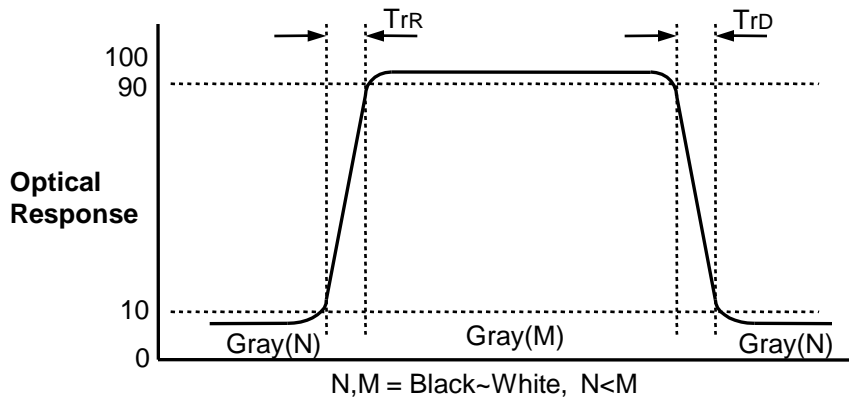
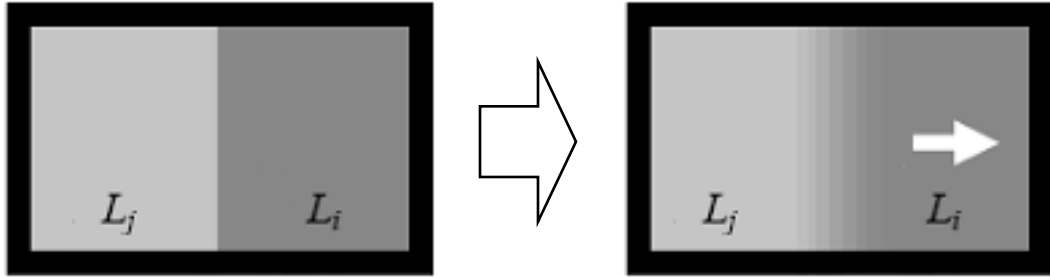

FIG. 3 Response Time

Product Specification

MPRT is defined as the 10% to 90% blur-edge with B_{ij} (pixels) and scroll speed U (pixels/frame)at the moving picture.



$$M = \frac{1}{U} B_{ij} \quad (i \neq j)$$

Example) $B_{ij} = 12\text{pixels}$, $U = 10\text{pixels} / 120\text{Hz}$

$$\begin{aligned} M &= 12\text{pixels} / (10\text{pixels} / 120\text{Hz}) \\ &= 12\text{pixels} / \{10\text{pixels} / (1/120)\text{s}\} \\ &= 12 / 1,200 \text{ s} \\ &= 10 \text{ ms} \end{aligned}$$

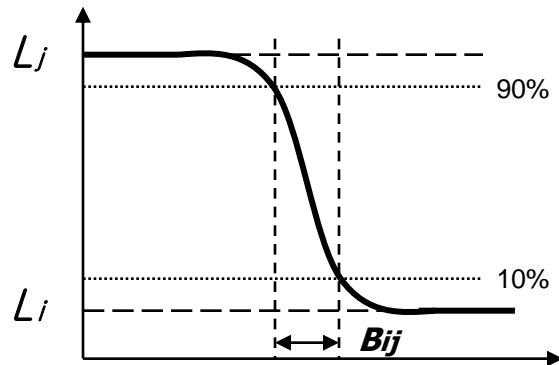

FIG. 4 MPRT

Dimension of viewing angle range

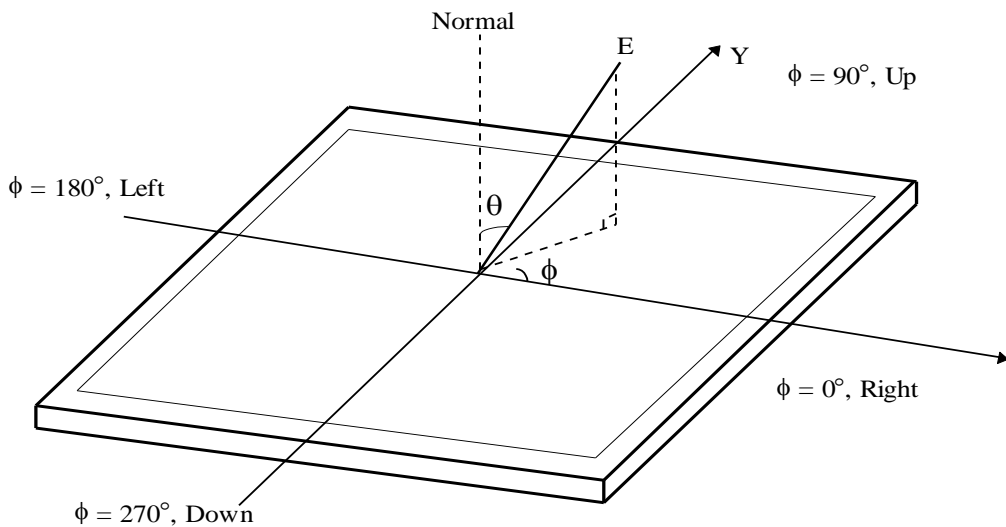
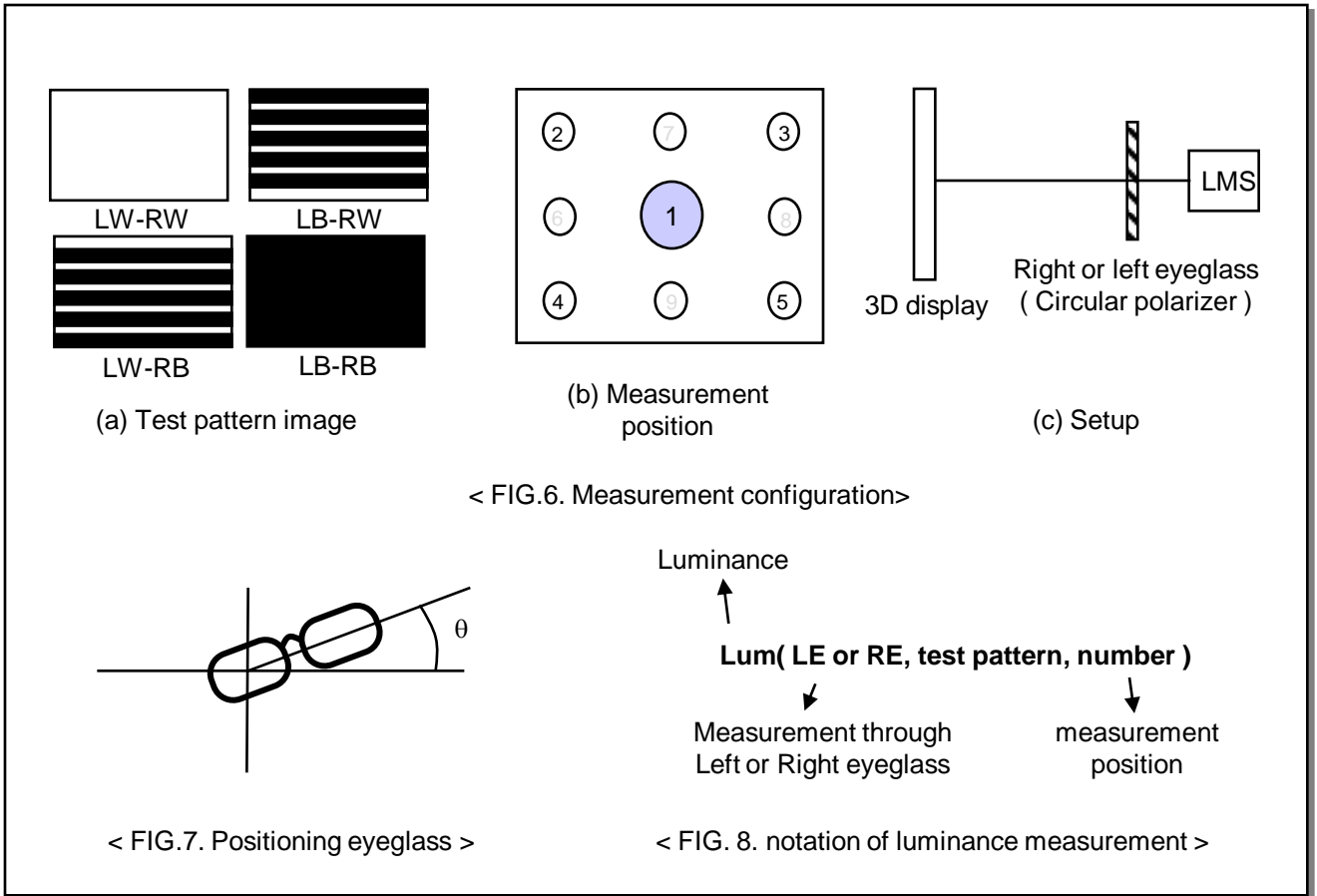

FIG. 5 Viewing Angle



In order to measure 3D luminance, 3D crosstalk and 3D viewing angle, it need to be prepared as below;

1) Measurement configuration

4-Test pattern images. Refer to FIG 8.

- LW-RW : White for left and right eye
- LW-RB : White for left eye and Black for right eye
- LB-RW : Black for left eye and white for right eye
- LB-RB : Black for left eye and right eye

Image files where black and white lines are displayed on even or odd lines.

Luminance measurement system (LMS) with narrow FOV (field of view) is used. Refer to FIG 1.

2) Positioning Eyeglass (refer to appendix-VIII for standard specification of eyeglass)

Find angle of minimum transmittance.

This value would be provided beforehand or measured by the following steps;

- (i) Test image (LB-RW) is displayed.
- (ii) Left eyeglass are placed in front of LMS and luminance is measured, rotating right eyeglass such as FIG 7. The notation for luminance measurement is “Lum(LE, LB-RW,1)”.
- (iii) Find the angle where luminance is minimum.

* Following measurements should be performed at the angle of minimum transmittance of eyeglass.

Product Specification

3) Measurement of 3D luminance

- (i) Test image (LW-RW) is displayed.
- (ii) Left or right eyeglass are placed in front of LMS successively and luminance is measured at center 1 point where the notation for luminance measurement is “Lum(LE, LW-RW,1)” or “Lum(RE, LW-RW,1).

4) Measurement of 3D crosstalk

- (i) Test image (LB-RW, LW-RB and LB-RB) is displayed.
- (ii) Right or left eyeglass are placed in front of LMS successively and luminance is measured for position 1. with rotating LMS or sample vertically.

$$\frac{\text{Lum(LE, LB-RW,1)} - \text{Lum(LE, LB-RB,1)}}{\text{Lum(LE, LW-RB,1)} - \text{Lum(LE, LB-RB,1)}}$$

or

$$\frac{\text{Lum(RE, LW-RB,1)} - \text{Lum(RE, LB-RB,1)}}{\text{Lum(RE, LB-RW,1)} - \text{Lum(RE, LB-RB,1)}}$$

5) Measurement of 3D Viewing Angle

3D viewing angle is the angle at which the 3D crosstalk is under 10%. The angles are determined for the vertical or y axis with respect to the z axis which is normal to the LCD module surface and measured for position 1. For more information , see the Fig 9

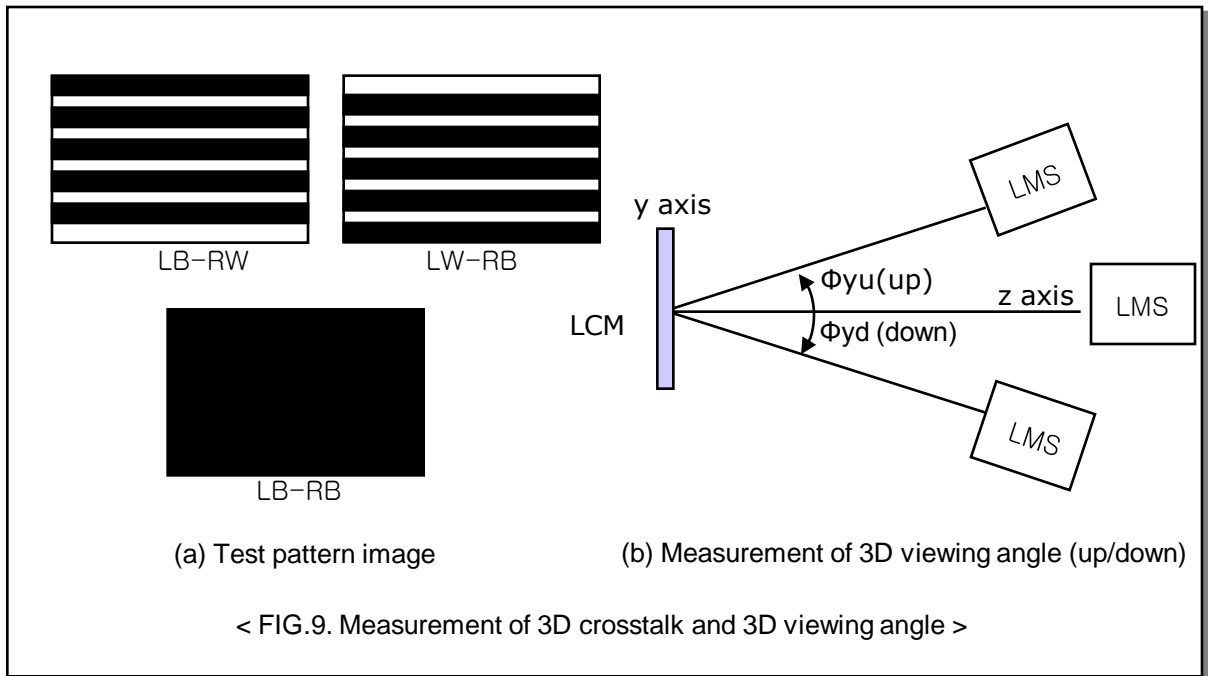

5. Mechanical Characteristics

Table 12 provides general mechanical characteristics.

Table 12. MECHANICAL CHARACTERISTICS

Item	Value	
Outline Dimension	Horizontal	1229.4 mm
	Vertical	711.8 mm
	Depth	20.7 mm
Bezel Area	Horizontal	1229.4 mm
	Vertical	694.3 mm
Active Display Area	Horizontal	1209.6mm
	Vertical	680.4mm
Weight	15.4 Kg (Typ.), 16.2kg (Max.)	

Note : Please refer to a mechanical drawing in terms of tolerance at the next page.

Product Specification

[FRONT VIEW]

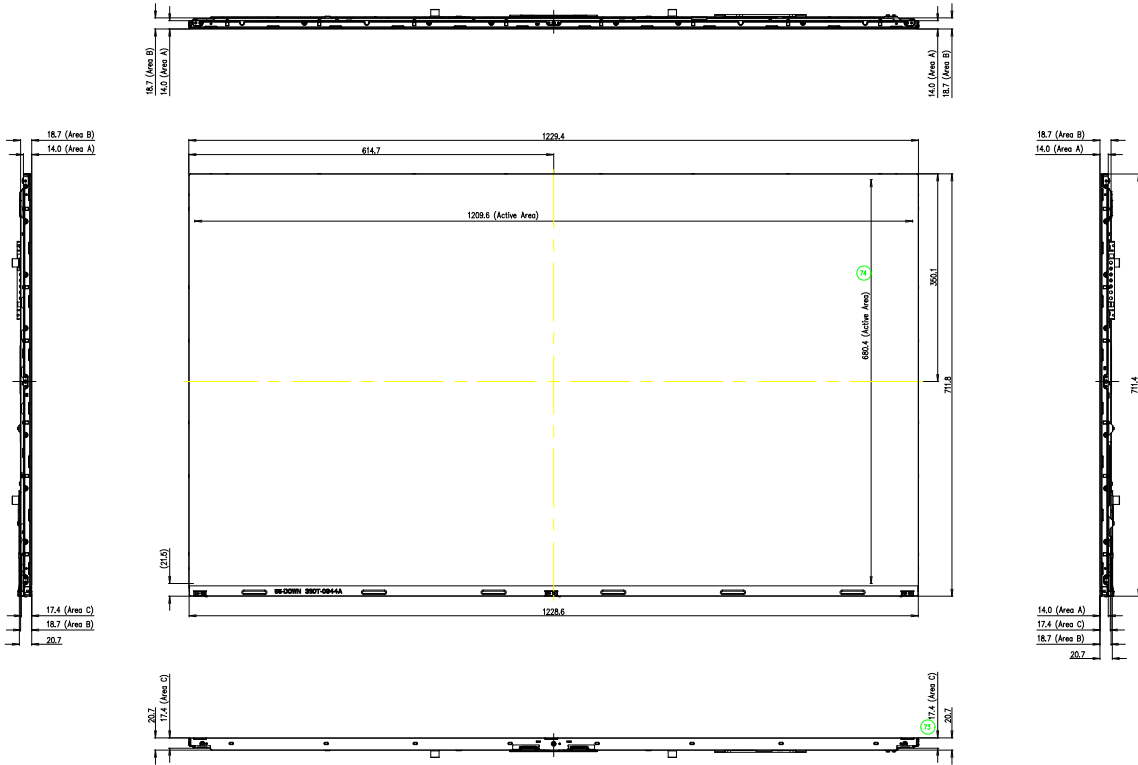

SECTION_VER_CENTER-VER_CENTER
SCALE 1/1

- NOTES:
 1. UNSTATED TOLERANCE IS ±1.0mm
 2. TILT AND PARTIAL DISPOSITION TOLERANCE OF DISPLAY AREA AS FOLLOWING.
 (1) Y-DIRECTION: 1 A-S ± 1.6
 (2) X-DIRECTION: 1 C-D ± 1.6
 3. Max. TORQUE = REFER TO TABLE
 4. Max. DEPTH = REFER TO TABLE
 5. THE SAME FEATURE MEANS THE SAME DIMENSION.
 6. SCREW HEAD Max. PROTRUSION: (X) 1.0mm
 7. SCREW Max. PROTRUSION: (Z) 2.0mm

Product Specification

[REAR VIEW]

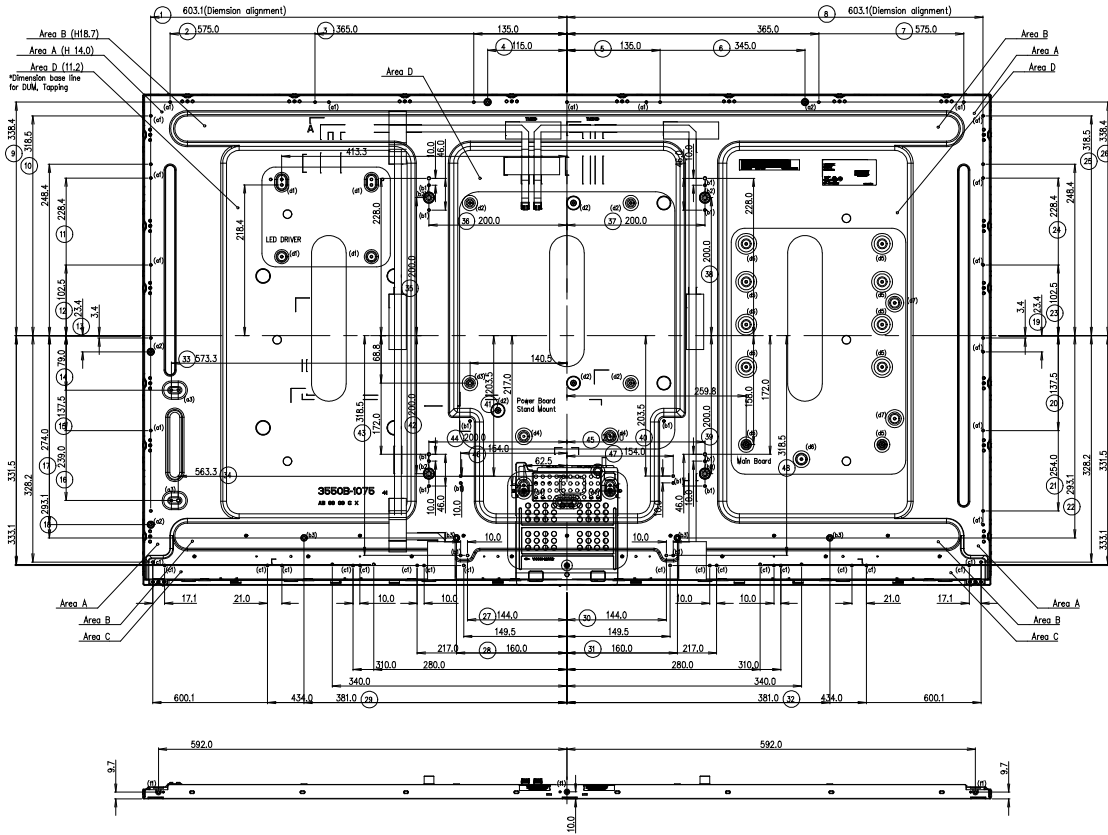
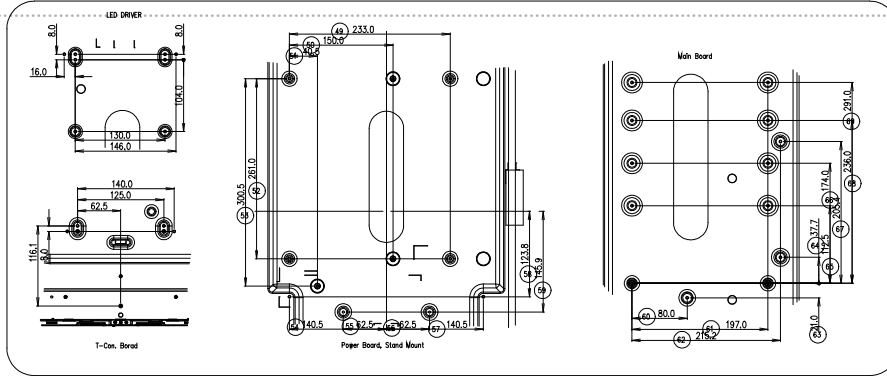

ITEM	TAP	Height (mm) from 295 file	Max Depth (mm)	Torque (kgf.cm)	Notes
(a1)	M3	14.0	2.8		Max 8.0
(a2)	M3	15.2	3.6		
(a3)	M3	23.0	10.5		
(b1)	M3	18.7	7.6		Max 10.0
(b2)	M6	33.0	12.5		
(b3)	M3	22.2	10.0		
(c1)	M3	17.4	6.2		Max 8.0
(d1)	M3	13.6	2.4		
(e2)	M3	15.2	4.0		
(e3)	M4	15.2	4.0		
(e4)	M3	15.2	4.0		
(e5)	M3	17.6	6.4		
(e6)	M3	14.0	2.8		
(e7)	M3	15.3	4.1		Side Mount
(f1)	M3	-	6.9		

Product Specification

6. Reliability

Table 13. ENVIRONMENT TEST CONDITION

No.	Test Item	Condition
1	High temperature storage test	Ta= 60°C 240h
2	Low temperature storage test	Ta= -20°C 240h
3	High temperature operation test	Ta= 50°C 50%RH 240h
4	Low temperature operation test	Ta= 0°C 240h
5	Humidity condition Operation	Ta= 40 °C ,90%RH
6	Vibration test (non-operating)	Wave form : random Vibration level : 0.5Grms Bandwidth : 10-300Hz Duration : X,Y,Z, Each direction per 10 min
7	Altitude operating storage / shipment	0 - 15,000 ft 0 - 40,000 ft

Note 1 : Before and after Reliability test, LCM should be operated with normal function.

7. International Standards

7-1. Safety

- a) UL 60065, Underwriters Laboratories Inc.
Audio, Video and Similar Electronic Apparatus - Safety Requirements.
- b) CAN/CSA C22.2 No.60065:03, Canadian Standards Association.
Audio, Video and Similar Electronic Apparatus - Safety Requirements.
- c) EN 60065, European Committee for Electrotechnical Standardization (CENELEC).
Audio, Video and Similar Electronic Apparatus - Safety Requirements.
- d) IEC 60065, The International Electrotechnical Commission (IEC).
Audio, Video and Similar Electronic Apparatus - Safety Requirements.
(Including report of IEC60825-1:2001 clause 8 and clause 9)

Notes

1. Laser (LED Backlight) Information

Class 1M LED Product
IEC60825-1 : 2001
Embedded LED Power (Class 1M)

2. Caution

- : LED inside.
- Class 1M laser (LEDs) radiation when open.
- Do not open while operating.

7-2. EMC

- a) ANSI C63.4 "American National Standard for Methods of Measurement of Radio-Noise Emissions from Low-Voltage Electrical and Electronic Equipment in the Range of 9 kHz to 40 GHz." American National Standards Institute (ANSI), 2003.
- b) CISPR 22 "Information technology equipment – Radio disturbance characteristics – Limit and methods of measurement." International Special Committee on Radio Interference (CISPR), 2005.
- c) CISPR 13 "Sound and television broadcast receivers and associated equipment – Radio disturbance characteristics – Limits and method of measurement." International Special Committee on Radio Interference (CISPR), 2006.

7-3. Environment

- a) RoHS, Directive 2002/95/EC of the European Parliament and of the council of 27 January 2003

8. Packing

8-1. Information of LCM Label

a) Lot Mark

A	B	C	D	E	F	G	H	I	J	K	L	M
---	---	---	---	---	---	---	---	---	---	---	---	---

A,B,C : SIZE(INCH)
E : MONTH

D : YEAR
F ~ M : SERIAL NO.

Note

1. YEAR

Year	2011	2012	2013	2014	2015	2016	2017	2018	2019	2020
Mark	A	B	C	D	E	F	G	H	J	K

2. MONTH

Month	Jan	Feb	Mar	Apr	May	Jun	Jul	Aug	Sep	Oct	Nov	Dec
Mark	1	2	3	4	5	6	7	8	9	A	B	C

b) Location of Lot Mark

Serial NO. is printed on the label. The label is attached to the backside of the LCD module.
This is subject to change without prior notice.

8-2. Packing Form

a) Package quantity in one Pallet : 16 pcs

b) Pallet Size : 1440 mm(W) X 1140 mm(D) X 950 mm(H)

9. Precautions

Please pay attention to the followings when you use this TFT LCD module.

9-1. Mounting Precautions

- (1) You must mount a module using specified mounting holes (Details refer to the drawings).
- (2) You should consider the mounting structure so that uneven force (ex. Twisted stress) is not applied to the module. And the case on which a module is mounted should have sufficient strength so that external force is not transmitted directly to the module.
- (3) Please attach the surface transparent protective plate to the surface in order to protect the polarizer. Transparent protective plate should have sufficient strength in order to resist external force.
- (4) You should adopt radiation structure to satisfy the temperature specification.
- (5) Acetic acid type and chlorine type materials for the cover case are not desirable because the former generates corrosive gas of attacking the polarizer at high temperature and the latter causes circuit break by electro-chemical reaction.
- (6) Do not touch, push or rub the exposed polarizers with glass, tweezers or anything harder than HB pencil lead. And please do not rub with dust clothes with chemical treatment. Do not touch the surface of polarizer for bare hand or greasy cloth. (Some cosmetics are detrimental to the polarizer.)
- (7) When the surface becomes dusty, please wipe gently with absorbent cotton or other soft materials like chamois soaks with petroleum benzine. Normal-hexane is recommended for cleaning the adhesives used to attach front / rear polarizers. Do not use acetone, toluene and alcohol because they cause chemical damage to the polarizer
- (8) Wipe off saliva or water drops as soon as possible. Their long time contact with polarizer causes deformations and color fading.
- (9) Do not open the case because inside circuits do not have sufficient strength.

9-2. Operating Precautions

- (1) Response time depends on the temperature. (In lower temperature, it becomes longer.)
- (2) Brightness depends on the temperature. (In lower temperature, it becomes lower.)
And in lower temperature, response time (required time that brightness is stable after turned on) becomes longer
- (3) Be careful for condensation at sudden temperature change. Condensation makes damage to polarizer or electrical contacted parts. And after fading condensation, smear or spot will occur.
- (4) When fixed patterns are displayed for a long time, remnant image is likely to occur.
- (5) Module has high frequency circuits. Sufficient suppression to the electromagnetic interference shall be done by system manufacturers. Grounding and shielding methods may be important to minimize the interference.
- (6) Please do not give any mechanical and/or acoustical impact to LCM. Otherwise, LCM can't be operated its full characteristics perfectly.
- (7) A screw which is fastened up the steels should be a machine screw.
(if not, it can cause conductive particles and deal LCM a fatal blow)
- (8) Please do not set LCD on its edge.

9-3. Electrostatic Discharge Control

Since a module is composed of electronic circuits, it is not strong to electrostatic discharge. Make certain that treatment persons are connected to ground through wrist band etc. And don't touch interface pin directly.

9-4. Precautions for Strong Light Exposure

Strong light exposure causes degradation of polarizer and color filter.

9-5. Storage

When storing modules as spares for a long time, the following precautions are necessary.

- (1) Store them in a dark place. Do not expose the module to sunlight or fluorescent light. Keep the temperature between 5°C and 35°C at normal humidity.
- (2) The polarizer surface should not come in contact with any other object.
It is recommended that they be stored in the container in which they were shipped.
- (3) Storage condition is guaranteed under packing conditions.
- (4) The phase transition of Liquid Crystal in the condition of the low or high storage temperature will be recovered when the LCD module returns to the normal condition

9-6. Operating condition guide

- (1) The LCD product should be operated under normal conditions. Normal condition is defined as below;
 - Temperature : 5 ~ 40 °C, normal humidity.
 - Display pattern : continually changing pattern (Not stationary)
- (2) If the product will be used in extreme conditions such as high temperature, display patterns or operation time etc.,
It is strongly recommended to contact LGD for Qualification engineering advice. Otherwise, its reliability and function may not be guaranteed. Extreme conditions are commonly found at Airports, Transit Stations, Banks, Stock market, and Controlling systems. The LCD product should be applied by global standard environment. (refer ETSI EN 300, IEC 60721)

APPENDIX-I

■ Pallet Ass'y

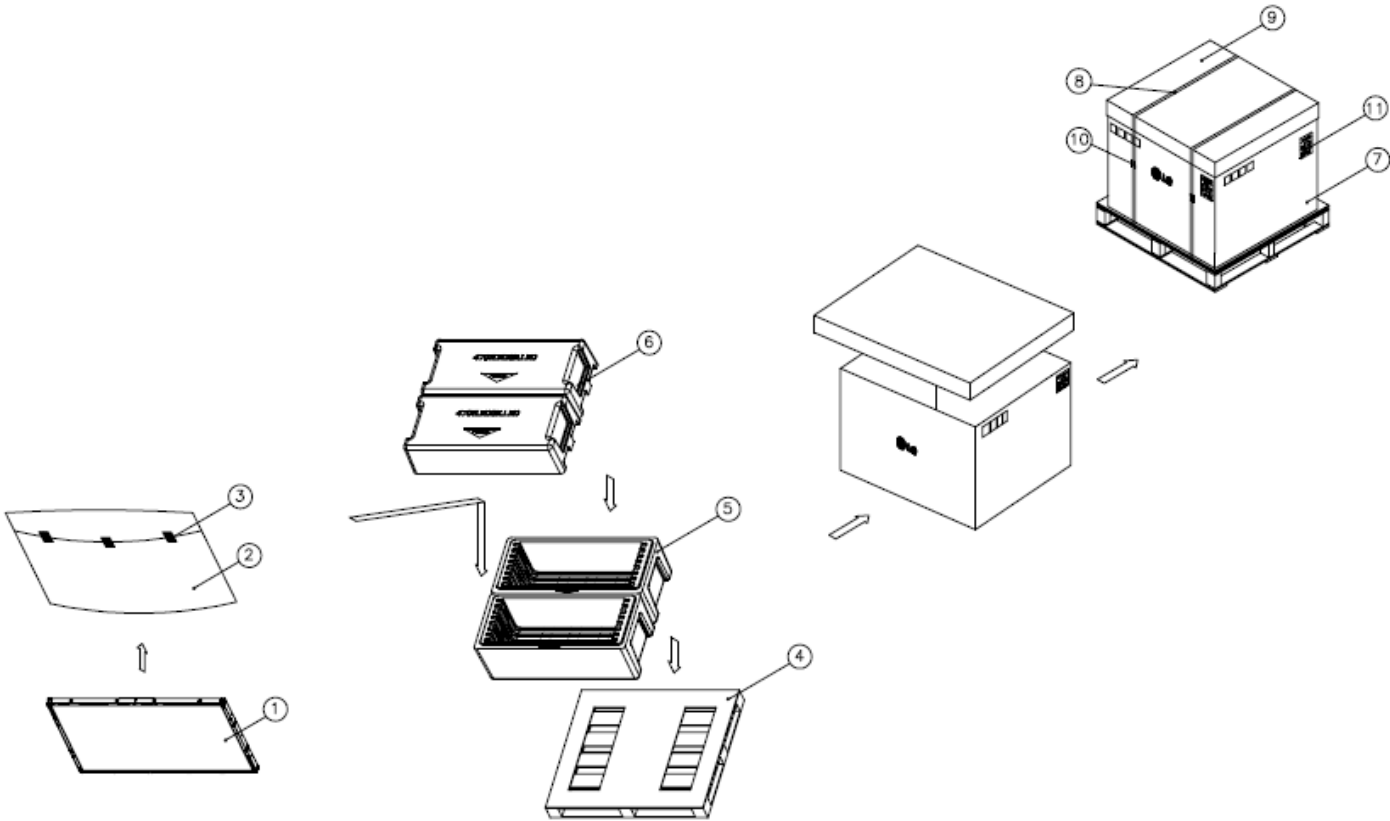

NO.	DESCRIPTION	MATERIAL
1	LCD Module	55" LCD
2	BAG	55INCH
3	TAPE	MASKING 20MMX50M
4	PALLET	Plywood 1440X1140X 950 mm
5	PACKING,BOTTOM	EPS
6	PACKING, TOP	EPS
7	ANGLE,PACKING	PAPER
8	BAND	PP
9	ANGLE,COVER	PAPER
10	BAND	STEEL OR PP
11	LABEL	YUPO 80G 100X70

Product Specification

APPENDIX- II-1

■ LCM Label



■ Serial No. (See CAS page 28 for more information)

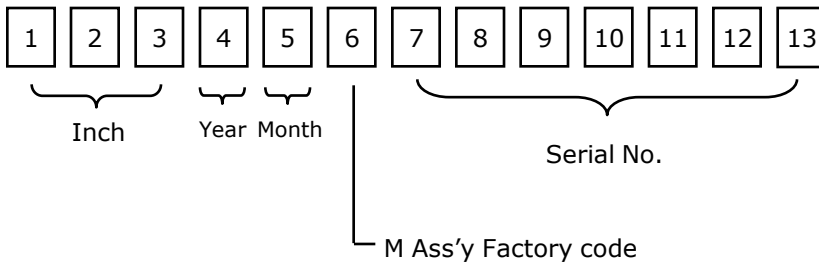

APPENDIX- II-2

■ Pallet Label



APPENDIX- III-1

■ Required signal assignment for Flat Link (Thine : THC63LVD103) Transmitter(Pin7= "L" or "NC")

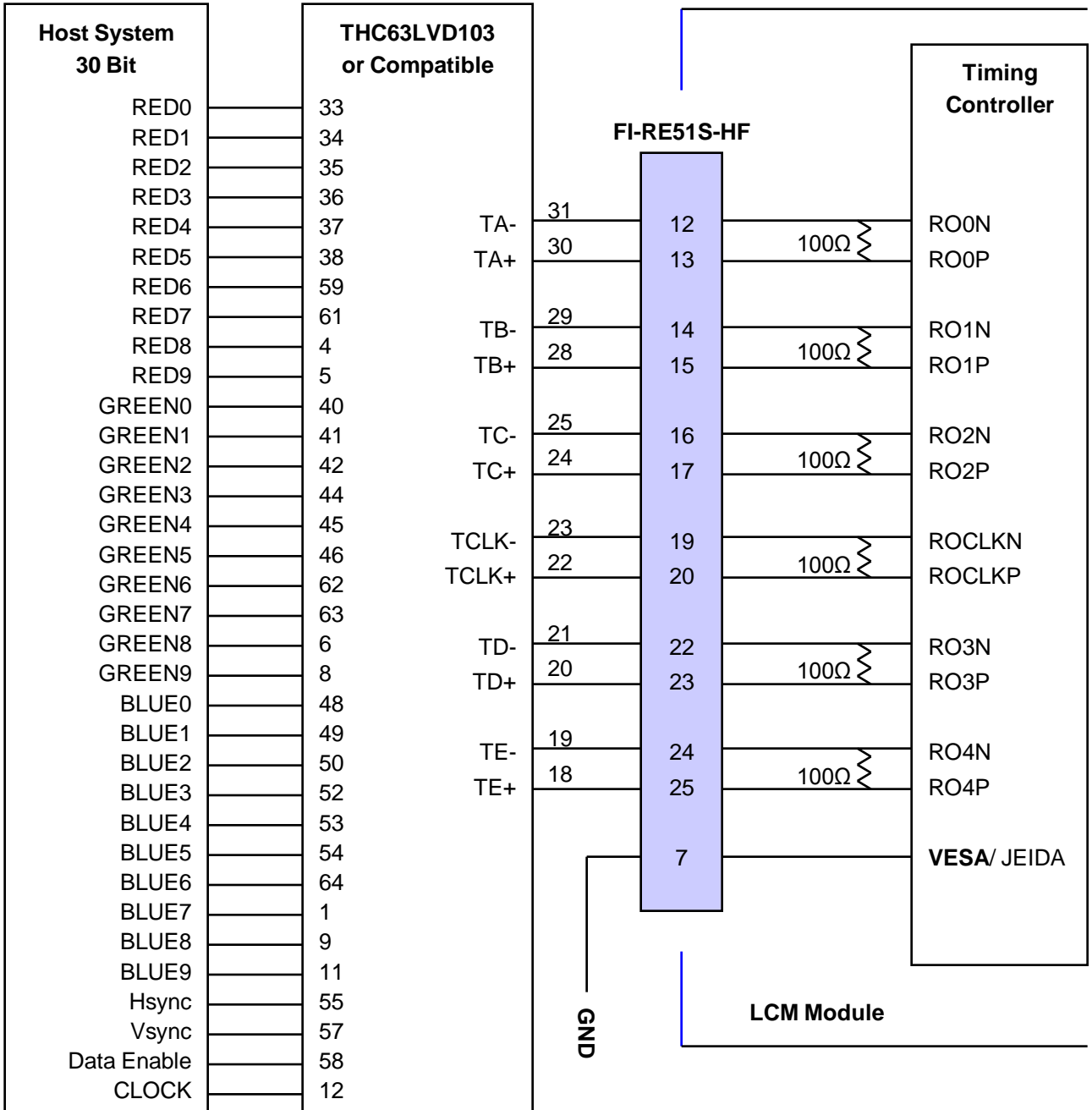

Note: 1. The LCD module uses a 100 Ohm[Ω] resistor between positive and negative lines of each receiver input.

2. Refer to LVDS Transmitter Data Sheet for detail descriptions. (THC63LVD103 or Compatible)

3. '9' means MSB and '0' means LSB at R,G,B pixel data.

APPENDIX- III-2

■ Required signal assignment for Flat Link (Thine : THC63LVD103) Transmitter(Pin7=“H”)

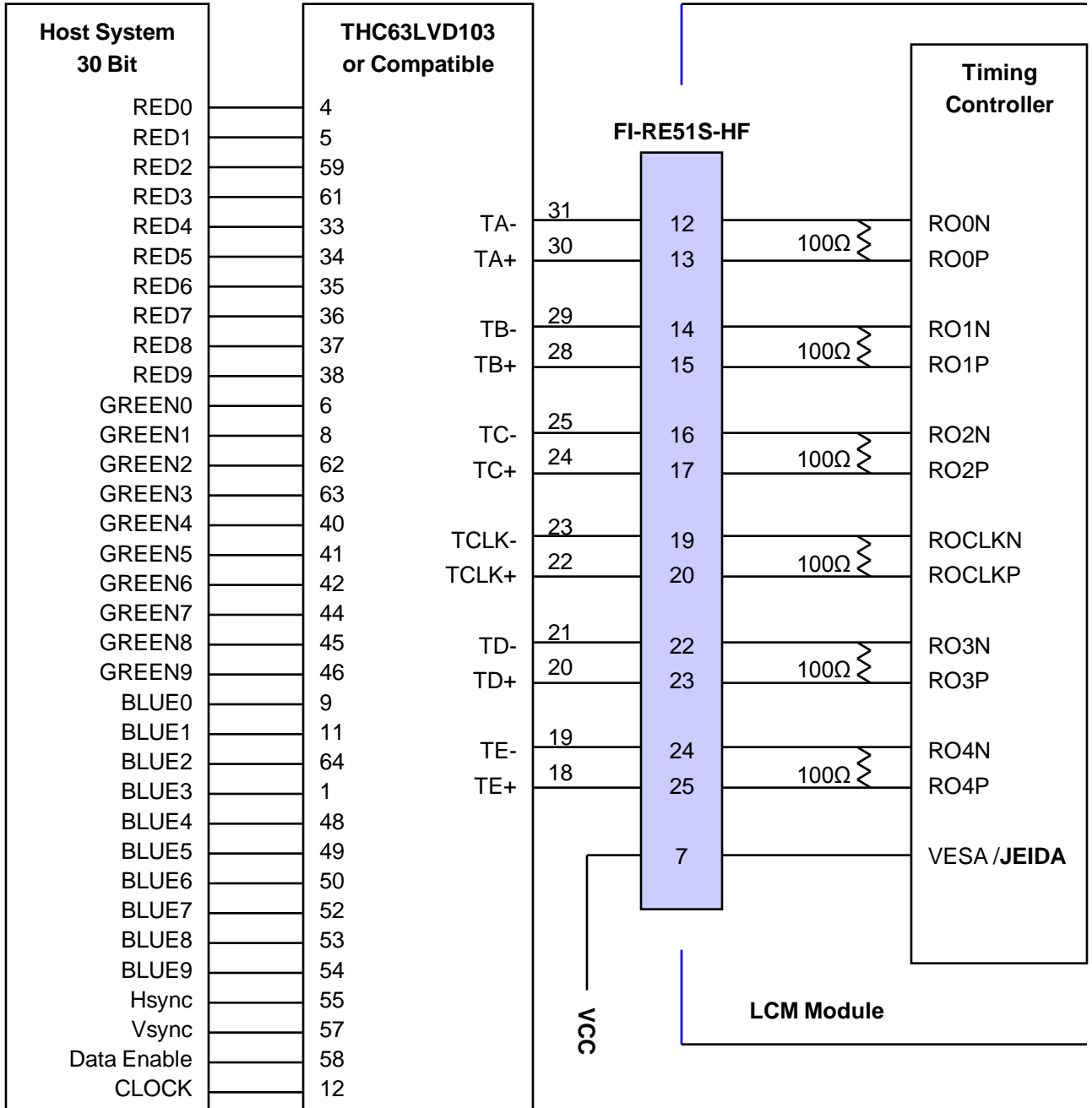

Note :1. The LCD module uses a 100 Ohm[Ω] resistor between positive and negative lines of each receiver input.

2. Refer to LVDS Transmitter Data Sheet for detail descriptions. (THC63LVD103 or Compatible)

3. '9' means MSB and '0' means LSB at R,G,B pixel data.

APPENDIX- IV-1

■ LVDS Data-Mapping Information (10 Bit)

1) LVDS Select : "H" Data-Mapping (JEIDA format)

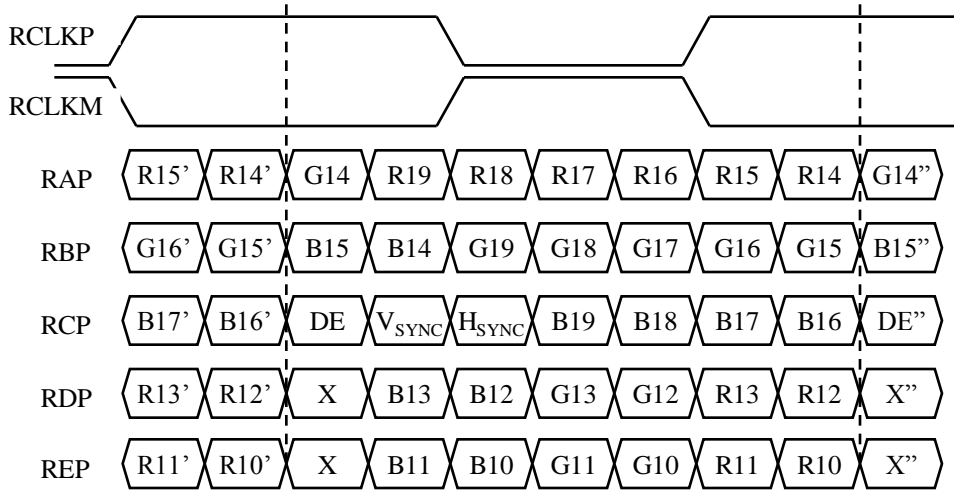

2) LVDS Select : "L" Data-Mapping (VESA format)

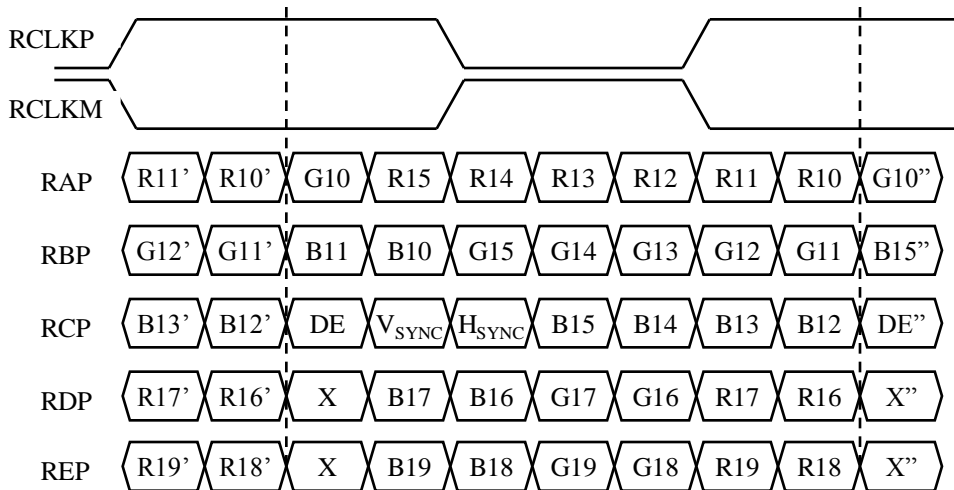

APPENDIX- IV-2

■ LVDS Data-Mapping Information (8 Bit)

1) LVDS Select : "H" Data-Mapping (JEIDA format)

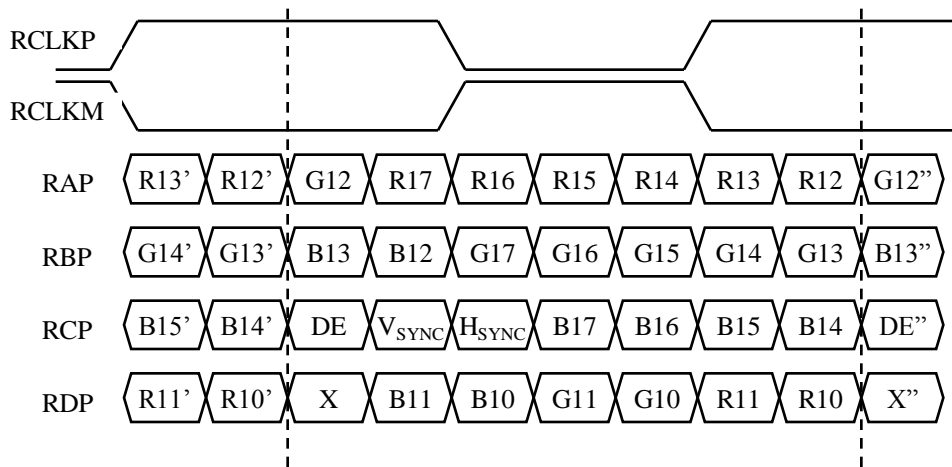

2) LVDS Select : "L" Data-Mapping (VESA format)

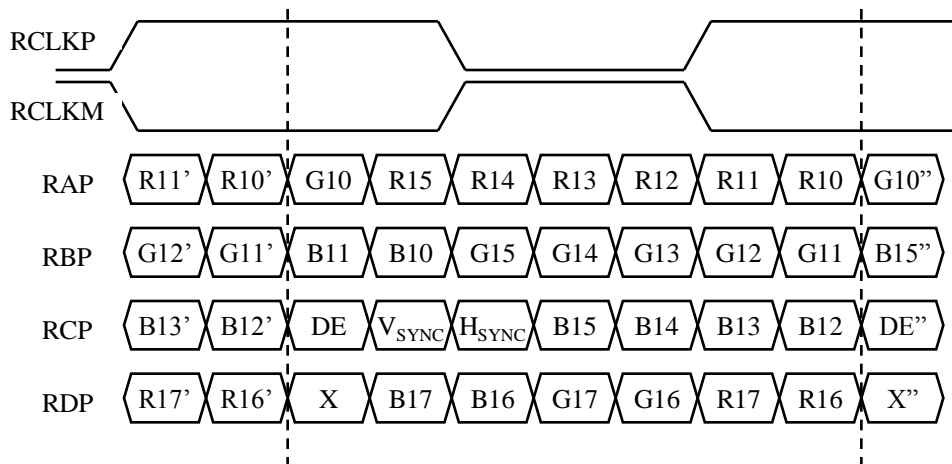

APPENDIX- V-1

■ Option Pin Circuit Block Diagram

1) Circuit Block Diagram of **LVDS** Selection pin

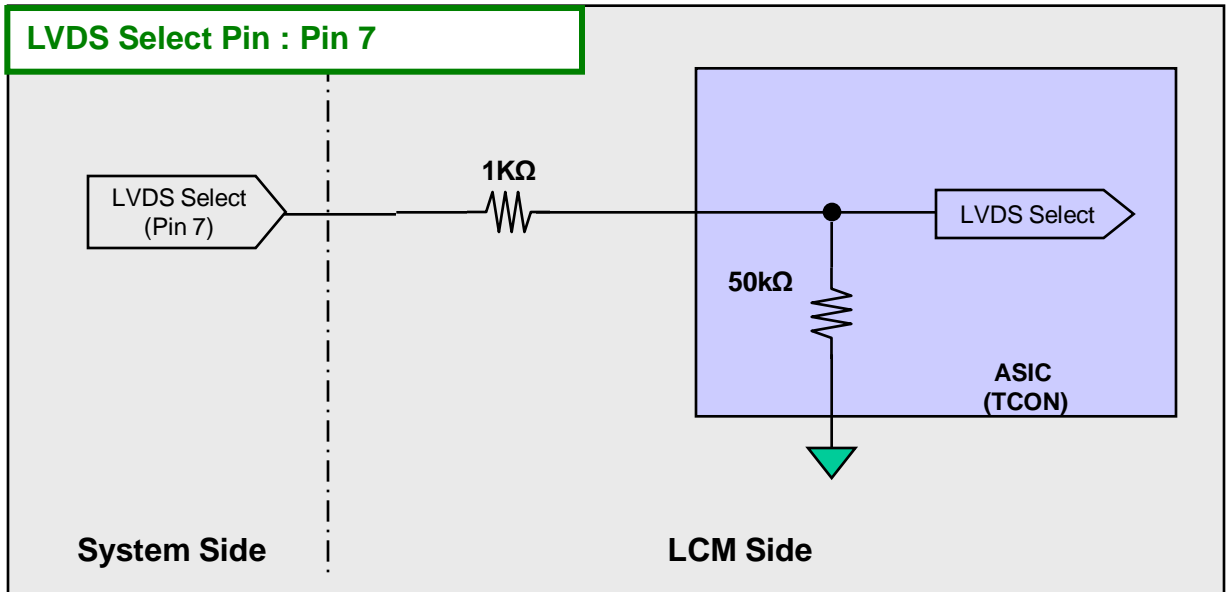

2) Circuit Block Diagram of **Bit** Selection pin

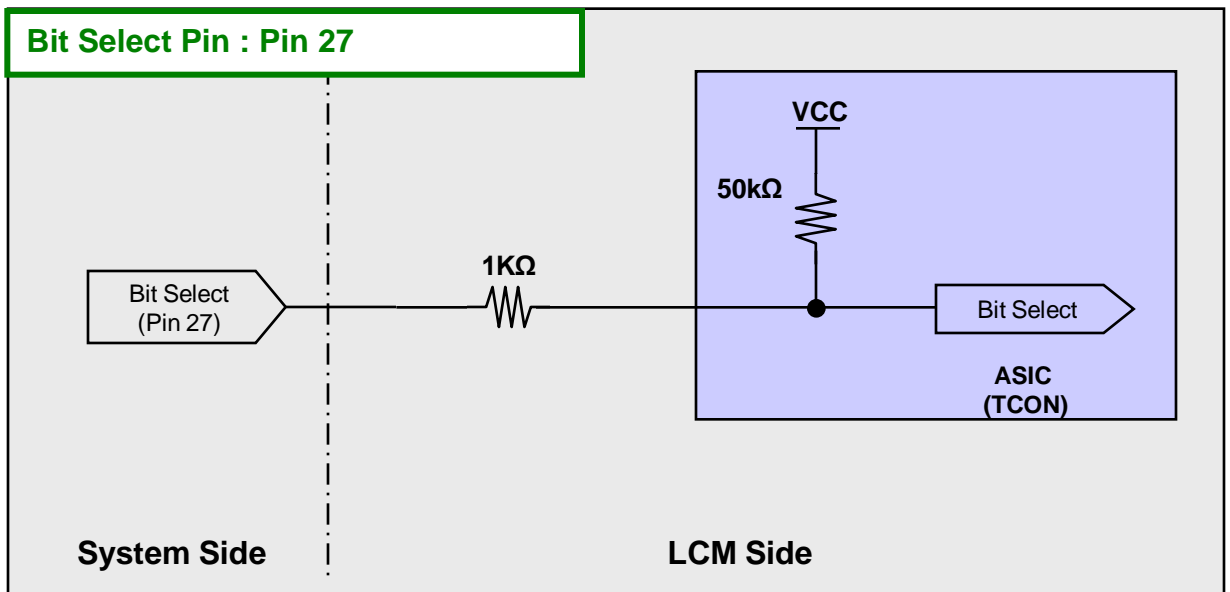

APPENDIX- V-2

■ Option Pin Circuit Block Diagram

3) Circuit Block Diagram of **PCID_EN** pin

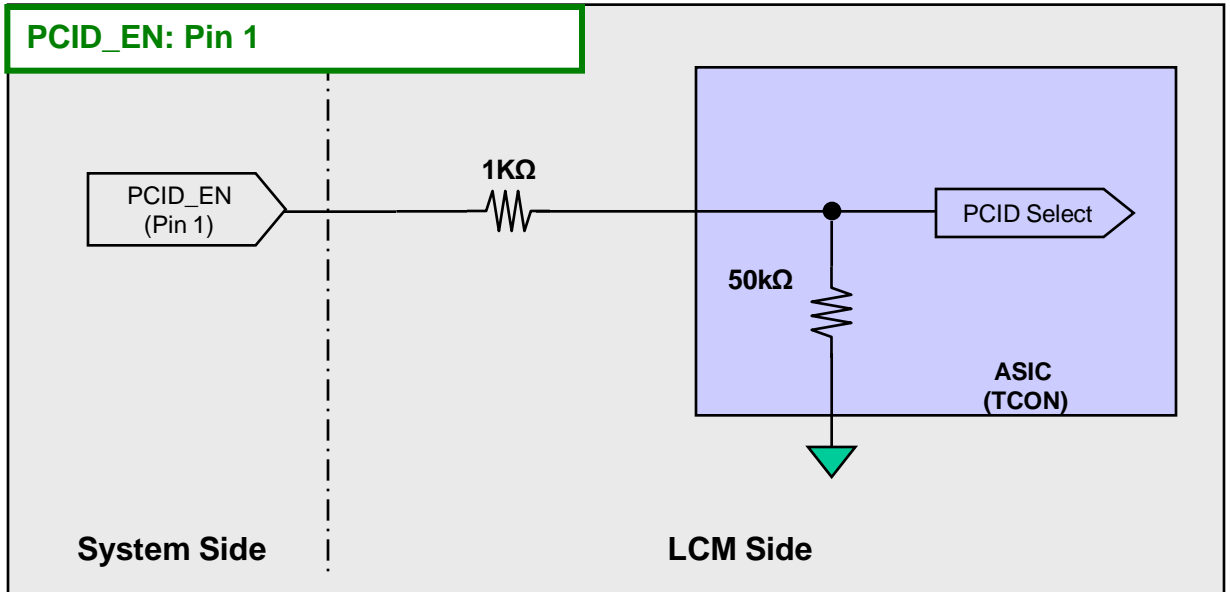

Product Specification

APPENDIX- VIII

■ Standard specification of Eyeglasses

This is recommended data of Eyeglasses for LC470EUF-FEP1 model. (details refer to table)

For each item, depending on the eyeglass manufacturer tolerances may occur, this tolerance can affect 3D performance. (3D Crosstalk, 3D luminance, 3D viewing angle)

<Table. Standard specification of Eyeglasses>

Design item of Eyeglasses		Left	Right	Remark
Optical axis	a) Slow axis of retarder	-45°	45°	Refer to drawing
	b) Transmission axis of polarizer	0°	0°	
Retardation value	Retarder	125nm		@550nm

※Recommended polarizer
Polarization efficiency: more than 99.90%

