

# SPECIFICATION FOR APPROVAL

- ( ) Preliminary Specification
- (●) Final Specification

Title	55.0" WUXGA TFT LCD
-------	---------------------

BUYER	LGE
MODEL	

SUPPLIER	LG Display Co., Ltd.
*MODEL	LC550EUG
SUFFIX	PFF1 (RoHS Verified)

APPROVED BY	SIGNATURE DATE
/	
/	
/	

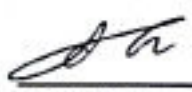
<b>APPROVED BY</b> H. S. Song / Team Leader	<b>SIGNATURE DATE</b>  2012.12.13
<b>REVIEWED BY</b> D. W. Lee / Project Leader	 2012. 12. 13
<b>PREPARED BY</b> C. H. Yu / Engineer	 2012. 12. 13

Please return 1 copy for your confirmation with your signature and comments.

**TV Product Development Dept.  
LG Display Co., Ltd.**

## Product Specification

**CONTENTS**

Number	ITEM	Page
	COVER	1
	CONTENTS	2
	RECORD OF REVISIONS	3
1	GENERAL DESCRIPTION	4
2	ABSOLUTE MAXIMUM RATINGS	5
3	ELECTRICAL SPECIFICATIONS	6
3-1	ELECTRICAL CHARACTERISTICS	6
3-2	INTERFACE CONNECTIONS	9
3-3	SIGNAL TIMING SPECIFICATIONS	12
3-4	PANEL PIXEL STRUCTURE	13
3-5	POWER SEQUENCE	14
4	OPTICAL SPECIFICATIONS	15
5	MECHANICAL CHARACTERISTICS	21
6	RELIABILITY	24
7	INTERNATIONAL STANDARDS	25
7-1	SAFETY	25
7-2	EMC	25
7-3	Environment	25
8	PACKING	26
8-1	DESIGNATION OF LOT MARK	26
8-2	PACKING FORM	26
9	PRECAUTIONS	27
9-1	MOUNTING PRECAUTIONS	27
9-2	OPERATING PRECAUTIONS	28
9-3	ELECTROSTATIC DISCHARGE CONTROL	28
9-4	PRECAUTIONS FOR STRONG LIGHT EXPOSURE	28
9-5	STORAGE	28
9-6	OPERAGING CONDITION GUIDE	28

Product Specification

RECORD OF REVISIONS

Table with 4 columns: Revision No., Revision Date, Page, and Description. It contains 5 rows of revision data and 24 empty rows.

## Product Specification

## 1. General Description

The LC550EUG is a Color Active Matrix Liquid Crystal Display with an integral Light Emitting Diode (LED) backlight system. The matrix employs a-Si Thin Film Transistor as the active element. It is a transmissive display type which is operating in the normally black mode. It has a 54.64 inch diagonally measured active display area with WUXGA resolution (1080 vertical by 1920 horizontal pixel array). Each pixel is divided into Red, Green and Blue sub-pixels or dots which are arrayed in vertical stripes. Gray scale or the luminance of the sub-pixel color is determined with a 8-bit gray scale signal for each dot. Therefore, it can present a palette of more than 16.7M(true) colors.

It is intended to support LCD TV, PCTV where high brightness, super wide viewing angle, high color gamut, high color depth and fast response time are important.

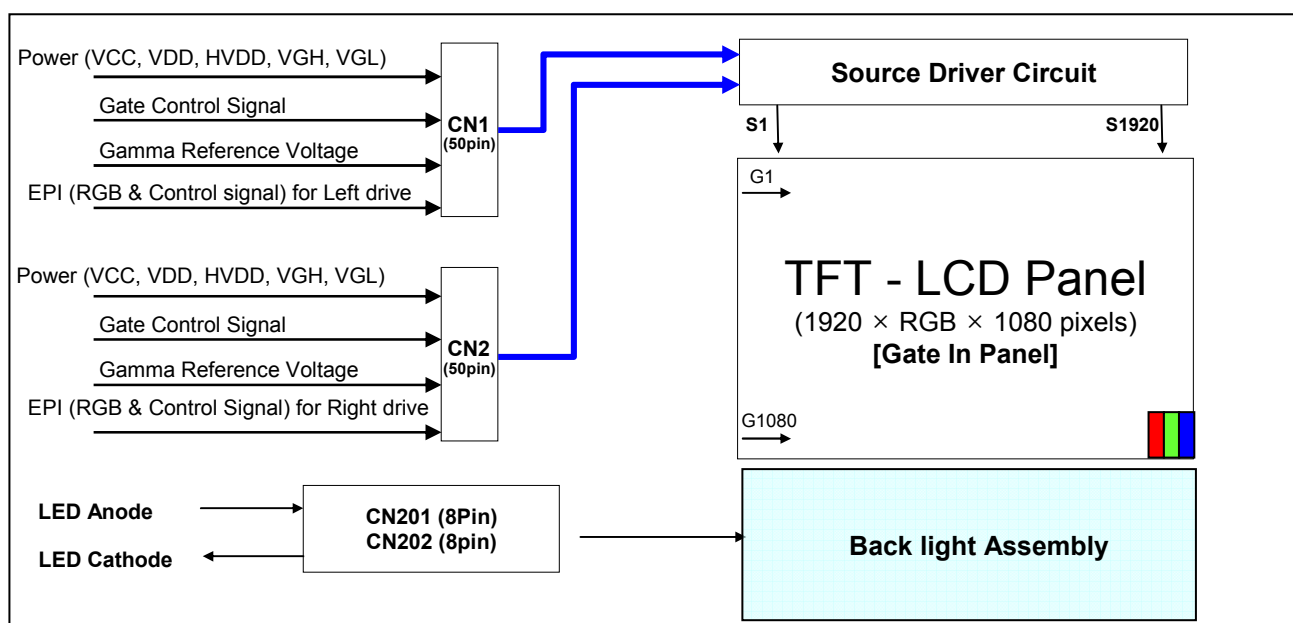

## General Features

Active Screen Size	54.64 inches(1387.80mm) diagonal
Outline Dimension	1229.4 X 706.3 X 9.9(B) /21.9(D)
Pixel Pitch	0.630 mm x 0.630 mm
Pixel Format	1920 horiz. by 1080 vert. Pixels, RGB stripe arrangement
Color Depth	8-bit, 16.7 M colors (※ 1.06B colors @ 10 bit (D) System Output )
Drive IC Data Interface	Source D-IC : 8-bit EPI, gamma reference voltage, and control signals Gate D-IC : Gate In Panel
Luminance, White	400cd/m <sup>2</sup> (Center 1point ,Typ.)
Viewing Angle (CR>10)	Viewing angle free ( R/L 178 (Min.), U/D 178 (Min.))
Power Consumption	Total 81.58 W (Typ.) (Logic= 7.28 W with T-CON LED Backlight=74.3W ( IF_cathode=150 mA)
Weight	15.0Kg (Typ.)
Display Mode	Transmissive mode, Normally black
Surface Treatment	Hard coating(2H), Anti-glare treatment of the front polarizer (Haze < 1%)

## Product Specification

## 2. Absolute Maximum Ratings

The following items are maximum values which, if exceeded, may cause faulty operation or permanent damage to the LCD module.

**Table 1. ABSOLUTE MAXIMUM RATINGS**

Parameter	Symbol	Value		Unit	Note
		Min	Max		
Logic & EPI Power Voltage	VCC	-0.5	+2.2	VDC	1
Gate High Voltage	VGH	+18.0	+30.0	VDC	
Gate Low Voltage	VGL	-8.0	-4.0	VDC	
Source D-IC Analog Voltage	VDD	-0.3	+18.0	VDC	
Gamma Ref. Voltage (Upper)	VGMH	$\frac{1}{2}VDD-0.5$	$VDD+0.5$	VDC	
Gamma Ref. Voltage (Low)	VGML	-0.3	$\frac{1}{2}VDD+0.5$	VDC	
LED Input Voltage	VF	-	+97.5	VDC	
Panel Front Temperature	TSUR	-	+68	°C	4
Operating Temperature	T <sub>OP</sub>	0	+50	°C	2,3
Storage Temperature	T <sub>ST</sub>	-20	+60	°C	
Operating Ambient Humidity	H <sub>OP</sub>	10	90	%RH	
Storage Humidity	H <sub>ST</sub>	10	90	%RH	

Note 1. Ambient temperature condition ( $T_a = 25 \pm 2 \text{ }^\circ\text{C}$ )

2. Temperature and relative humidity range are shown in the figure below.

Wet bulb temperature should be Max 39°C, and no condensation of water.

3. Gravity mura can be guaranteed below 40°C condition.

4. The maximum operating temperatures is based on the test condition that the surface temperature of display area is less than or equal to 68°C with LCD module alone in a temperature controlled chamber. Thermal management should be considered in final product design to prevent the surface temperature of display area from being over 68°C. The range of operating temperature may be degraded in case of improper thermal management in final product design.

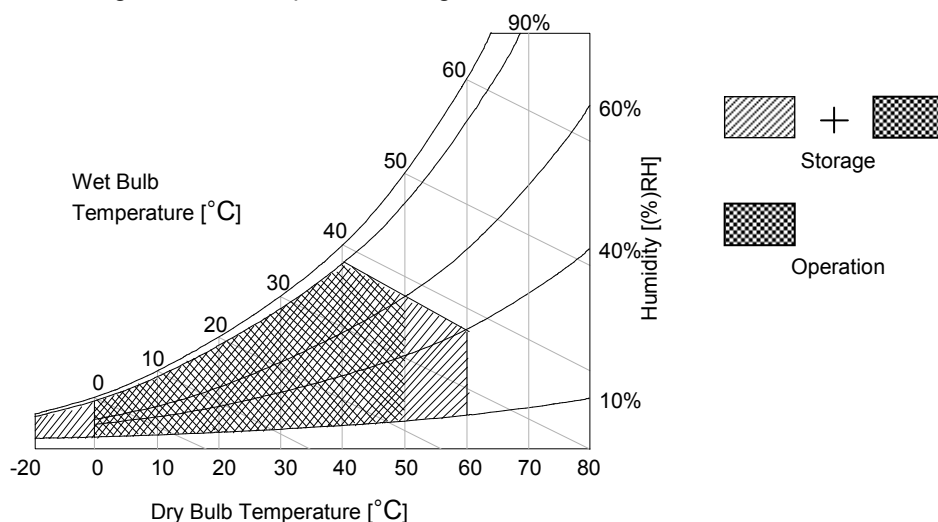

## Product Specification

**3. Electrical Specifications****3-1. Electrical Characteristics**

It requires several power inputs. The VCC is the basic power of LCD Driving power sequence, Which is used to logic power voltage of Source D-IC and GIP.

**Table 2. ELECTRICAL CHARACTERISTICS**

Parameter	Symbol	Condition	MIN	TYP	MAX	Unit	Note
Logic Power Voltage	VCC	-	1.62	1.8	1.98	V <sub>DC</sub>	
Logic High Level Input Voltage	V <sub>IH</sub>	-	1.4	-	VCC	V <sub>DC</sub>	
Logic Low Level Input Voltage	V <sub>IL</sub>	-	0	-	0.4	V <sub>DC</sub>	
Source D-IC Analog Voltage	VDD	-	15.8	16.0	16.2	V <sub>DC</sub>	
Half Source D-IC Analog Voltage	H_VDD	-	7.8	8.0	8.2	V <sub>DC</sub>	6
Gamma Reference Voltage	V <sub>GMH</sub>	(GMA1 ~ GMA9)	H_VDD+0.2V	-	VDD-0.2	V <sub>DC</sub>	
	V <sub>GML</sub>	(GMA10 ~ GMA18)	0.2	-	H_VDD-0.2V	V <sub>DC</sub>	
Common Voltage	Vcom	Reverse	6.75	7.05	7.35	V	
EPI input common voltage	VCM	LVDS Type	0.8	VCC/2	1.3	V	5
EPI input differential voltage	Vdiff	-	150	-	500	mV	
EPI Input eye diagram	Veye	-	90	-	-	mV	
Gate High Voltage	VGH	@ 25°C	27.7	28	28.3	V <sub>DC</sub>	
		@ 0°C	29.7	30	30.3	V <sub>DC</sub>	
Gate Low Voltage	VGL	-	-6.8	-7	-7.2	V <sub>DC</sub>	
GIP Bi-Scan Voltage	VGI_P	-	VGL	-	-	V <sub>DC</sub>	
	VGI_N	-	-	-	VGH	V <sub>DC</sub>	
GIP Refresh Voltage	VGH even/odd	-	VGL	-	VGH	V	
GIP Start Pulse Voltage	VST	-	VGL	-	VGH	V	
GIP Operating Clock	GCLK	-	VGL	-	VGH	V	
Total Power Current	ILCD	-	-	607	758	mA	1
Total Power Consumption	PLCD	-	-	7.28	9.1	Watt	1

- Note:
1. The specified current and power consumption are under the V<sub>LCD</sub>=12V., 25 ± 2°C, f<sub>v</sub>=60Hz condition whereas mosaic pattern(8 x 6) is displayed and f<sub>v</sub> is the frame frequency.
  2. The above spec is based on the basic model.
  3. All of the typical gate voltage should be controlled within 1% voltage level
  4. Ripple voltage level is recommended under ±5% of typical voltage
  5. In case of EPI signal spec, refer to Fig 2 for the more detail.
  6. HVDD Voltage level is half of VDD and it should be between Gamma9 and Gamma10.

Product Specification

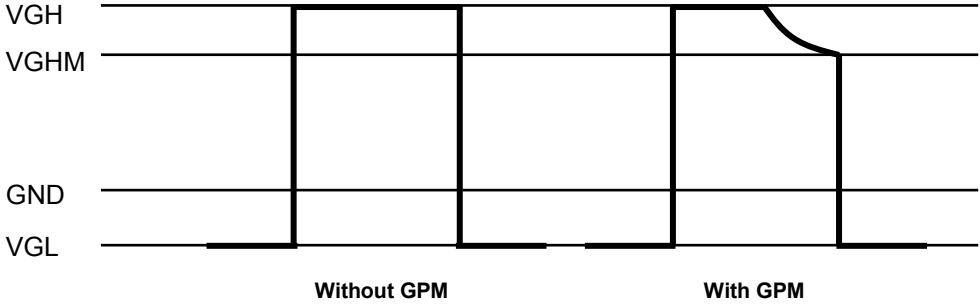

FIG. 1 Gate Output Wave form without GPM and with GPM

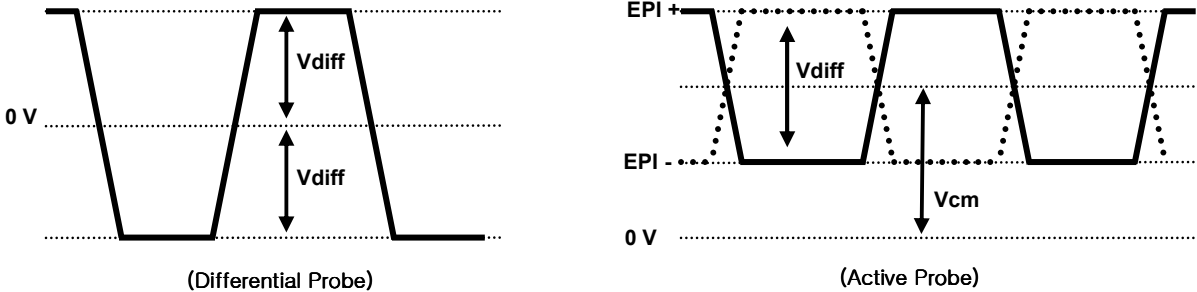

FIG. 2-1 EPI Differential signal characteristics

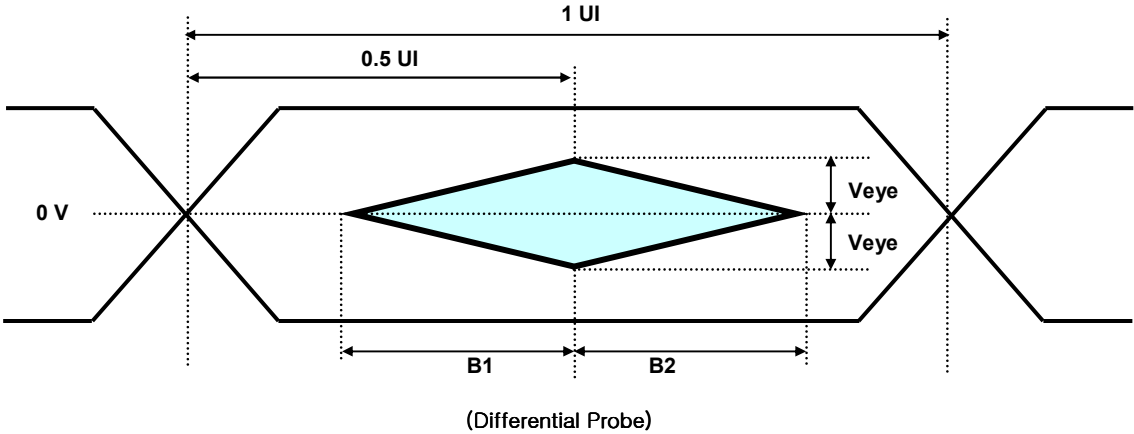

FIG. 2-2 Eye Pattern of EPI Input

\*Source PCB

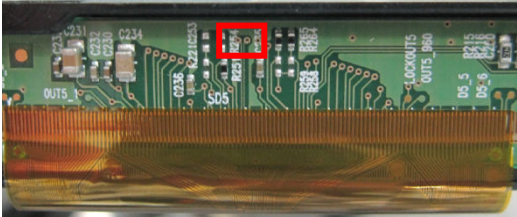

FIG. 3 Measure point

## Product Specification

Table 3. ELECTRICAL CHARACTERISTICS (Continue)

Parameter	Symbol	Values			Unit	Note	
		Min	Typ	Max			
<b>Backlight Assembly :</b>							
Forward Current (one array)	Anode	$I_{F (anode)}$		450		mAdc	±5%
	Cathode	$I_{F (cathode)}$	142.5	150	157.5	mAdc	2, 3
Forward Voltage		$V_F$	75.0	82.5	87.5	Vdc	4
Forward Voltage Variation		$\Delta V_F$			1.7	Vdc	5
Power Consumption		$P_{BL}$		74.3	78.8	W	6
Burst Dimming Duty		On duty	1		100	%	
Burst Dimming Frequency		1/T	95		182	Hz	8
<b>LED Array :</b>							
Life Time			30,000	50,000		Hrs	7

Note : The design of the LED driver must have specifications for the LED array in LCD Assembly.

The electrical characteristics of LED driver are based on Constant Current driving type.

The performance of the LED in LCM, for example life time or brightness, is extremely influenced by the characteristics of the LED Driver. So, all the parameters of an LED driver should be carefully designed.

When you design or order the LED driver, please make sure unwanted lighting caused by the mismatch of the LED and the driver (no lighting, flicker, etc) has never been occurred. When you confirm it, the LCD-Assembly should be operated in the same condition as installed in your instrument.

1. Electrical characteristics are based on LED Array specification.

2. Specified values are defined for a Backlight Assembly. (IBL : 2 LED array/LCM)

3. Each LED array has one anode terminal and 3 cathode terminals.

The forward current( $I_F$ ) of the anode terminal is 450mA and it supplies 150mA into 3 strings, respectively

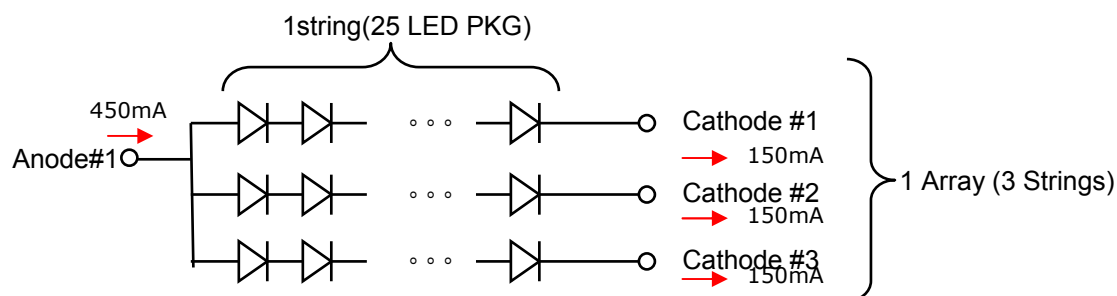

4. The forward voltage( $V_F$ ) of LED array depends on ambient temperature (Appendix-V)

5.  $\Delta V_F$  means Max  $V_F$ -Min  $V_F$  in one Backlight. So  $V_F$  variation in a Backlight isn't over Max. 1.7V

6. Maximum level of power consumption is measured at initial turn on.

Typical level of power consumption is measured after 1hrs aging at  $25 \pm 2^\circ\text{C}$ .

7. The life time(MTTF) is determined as the time at which brightness of the LED is 50% compared to that of initial value at the typical LED current on condition of continuous operating at  $25 \pm 2^\circ\text{C}$ , based on duty 100%.

8. The reference method of burst dimming duty ratio.

It is recommended to use synchronous V-sync frequency to prevent waterfall

(Vsync x 2 =Burst Frequency)

Though PWM frequency is over 182Hz (max252Hz), function of backlight is not affected.



## Product Specification

**3-2. Interface Connections**

This LCD module employs two kinds of interface connection, two 50-pin FFC connector are used for the module electronics and 8-pin / 8-pin connectors are used for the integral backlight system.

**3-2-1. LCD Module**

-LCD Connector (CN1): TF06L-50S-0.5SH (Manufactured by HRS) or Compatible

**Table 3-1. MODULE CONNECTOR(CN1) PIN CONFIGURATION**

No	Symbol	Description	No	Symbol	Description
1	LTD_OUT	LTD OUTPUT	26	GND	Ground
2	NC	No Connection	27	EPI2-	EPI Receiver Signal(2-)
3	GCLK1	GIP GATE Clock 1	28	EPI2+	EPI Receiver Signal(2+)
4	GCLK2	GIP GATE Clock 2	29	GND	Ground
5	GCLK3	GIP GATE Clock 3	30	GND	Ground
6	GCLK4	GIP GATE Clock 4	31	EPI1-	EPI Receiver Signal(1-)
7	GCLK5	GIP GATE Clock 5	32	EPI1+	EPI Receiver Signal(1+)
8	GCLK6	GIP GATE Clock 6	33	GND	Ground
9	VGI_N	GIP Bi-Scan (VGI_N = VGH)	34	VCC	Logic & EPI Power Voltage
10	VGI_P	GIP Bi-Scan (VGI_P = VGL)	35	Vterm	Vterm Power Voltage
11	VGH_ODD	GIP Panel VDD for Odd GATE TFT	36	LOCKOUT3	LOCKOUT3
12	VGH_EVEN	GIP Panel VDD for Even GATE TFT	37	NC	No Connection
13	VGL	GATE Low Voltage	38	GND	Ground
14	VST	VERTICAL START PULSE	39	GMA 18	GAMMA VOLTAGE 18 (Output From LCD)
15	GIP_Reset	GIP Reset	40	GMA 16	GAMMA VOLTAGE 16
16	VCOM_L_FB	VCOM Left Feed-Back Output	41	GMA 15	GAMMA VOLTAGE 15
17	VCOM_L	VCOM Left Input	42	GMA 14	GAMMA VOLTAGE 14
18	GND	Ground	43	GMA 12	GAMMA VOLTAGE 12
19	VDD	Driver Power Supply Voltage	44	GMA 10	GAMMA VOLTAGE 10 (Output From LCD)
20	VDD	Driver Power Supply Voltage	45	GMA 9	GAMMA VOLTAGE 9 (Output From LCD)
21	H_VDD	Half Driver Power Supply Voltage	46	GMA 7	GAMMA VOLTAGE 7
22	GND	Ground	47	GMA 5	GAMMA VOLTAGE 5
23	EPI3-	EPI Receiver Signal(3-)	48	GMA 4	GAMMA VOLTAGE 4
24	EPI3+	EPI Receiver Signal(3+)	49	GMA 3	GAMMA VOLTAGE 3
25	GND	Ground	50	GMA 1	GAMMA VOLTAGE 1(Output From LCD)

Note :

1. Please refer to application note for details.  
(GIP & Half VDD & Gamma Voltage setting)

## Product Specification

-LCD Connector (CN1): TF06L-50S-0.5SH (Manufactured by HRS) or Compatible

**Table 3-2. MODULE CONNECTOR(CN2) PIN CONFIGURATION**

No	Symbol	Description	No	Symbol	Description
1	GMA 1	GAMMA VOLTAGE 1 (Output From LCD)	26	GND	Ground
2	GMA 3	GAMMA VOLTAGE 3	27	EPI1-	EPI Receiver Signal(4-)
3	GMA 4	GAMMA VOLTAGE 4	28	EPI1+	EPI Receiver Signal(4+)
4	GMA 5	GAMMA VOLTAGE 5	29	GND	Ground
5	GMA 7	GAMMA VOLTAGE 7	30	H_VDD	Half Driver Power Supply Voltage
6	GMA 9	GAMMA VOLTAGE 9 (Output From LCD)	31	VDD	Driver Power Supply Voltage
7	GMA 10	GAMMA VOLTAGE 10 (Output From LCD)	32	VDD	Driver Power Supply Voltage
8	GMA 12	GAMMA VOLTAGE 12	33	GND	Ground
9	GMA 14	GAMMA VOLTAGE 14	34	VCOM_R	VCOM Right Input
10	GMA 15	GAMMA VOLTAGE 15	35	VCOM_R_FB	VCOM Right Feed-Back Output
11	GMA 16	GAMMA VOLTAGE 16	36	GIP_Reset	GIP Reset
12	GMA 18	GAMMA VOLTAGE 18 (Output From LCD)	37	VST	VERTICAL START PULSE
13	GND	Ground	38	VGL	GATE Low Voltage
14	LOCKOUT6	LOCKOUT6	39	VGH_EVEN	GIP Panel VDD for Even GATE TFT
15	LOCKIN3	LOCKIN3	40	VGH_ODD	GIP Panel VDD for Odd GATE TFT
16	Vterm	Vterm Power Voltage	41	VGI_P	GIP Bi-Scan (VGI_P = VGL)
17	VCC	Logic & EPI Power Voltage	42	VGI_N	GIP Bi-Scan (VGI_N = VGH)
18	GND	Ground	43	GCLK6	GIP GATE Clock 6
19	EPI6-	EPI Receiver Signal(6-)	44	GCLK5	GIP GATE Clock 5
20	EPI6+	EPI Receiver Signal(6+)	45	GCLK4	GIP GATE Clock 4
21	GND	Ground	46	GCLK3	GIP GATE Clock 3
22	GND	Ground	47	GCLK2	GIP GATE Clock 2
23	EPI5-	EPI Receiver Signal(5-)	48	GCLK1	GIP GATE Clock 1
24	EPI5+	EPI Receiver Signal(5+)	49	NC	No Connection
25	GND	Ground	50	LTD_OUT	LTD OUTPUT

Note : 1. Please refer to application note for details.

(GIP & Half VDD & Gamma Voltage setting)

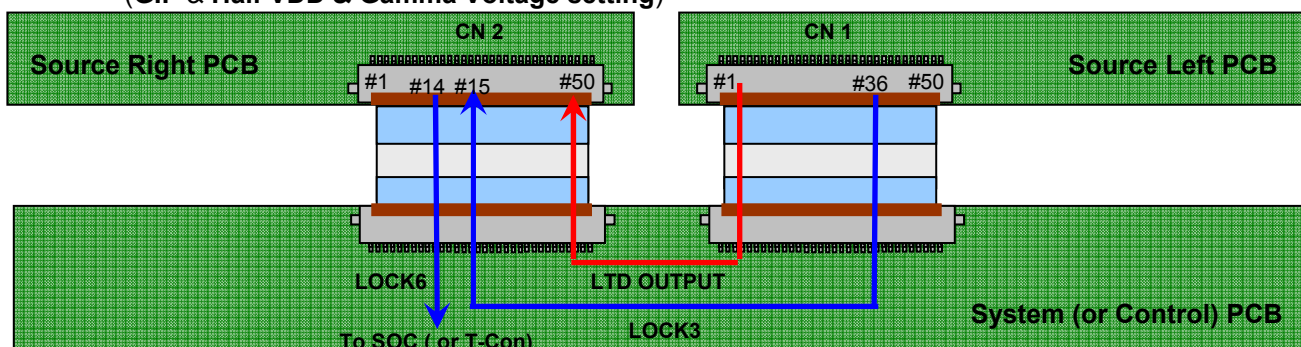

## Product Specification

## 3-2-2. Backlight Module

## [ CN201 ]

- 1) LED Array assy Connector (Plug)  
: HS100-L08N-N62 (black color, manufactured by UJU)
- 2) Mating Connector (Receptacle)  
: IS100-L08T-C46 (black color, manufactured by UJU)

## [ CN202 ]

- 1) LED Array assy Connector (Plug)  
: HS100-L08N-N62-A (natural color, manufactured by UJU)
- 2) Mating Connector (Receptacle)  
: IS100-L08T-C46-A (natural color, manufactured by UJU)

Table 4. BACKLIGHT CONNECTOR PIN CONFIGURATION(CN201,CN202)

No	Symbol(CN201)	Description	Note
1	L1 Cathode	LED Output Current	
2	L2 Cathode	LED Output Current	
3	L3 Cathode	LED Output Current	
4	N.C	Open	
5	N.C	Open	
6	N.C	Open	
7	N.C	Open	
8	Anode_L	LED Input Current for L1~L3	

No	Symbol(CN202)	Description	Note
1	Anode_R	LED Input Current for R1~R3	
2	N.C	Open	
3	N.C	Open	
4	N.C	Open	
5	N.C	Open	
6	R1 Cathode	LED Output Current	
7	R2 Cathode	LED Output Current	
8	R3 Cathode	LED Output Current	

## ◆ Rear view of LCM

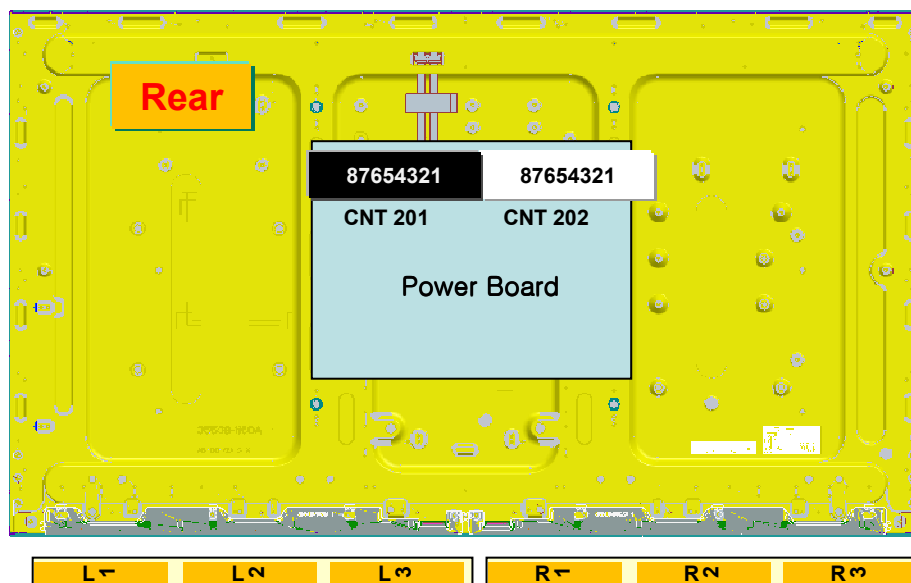

Product Specification

### 3-3. Signal Timing Specifications

**Table 5. Timing Requirements**

Parameter	Symbol	Condition	Min	Typ	Max	Unit	notes
Unit Interval	UI	-	1.37	1.44	1.70	ns	
Effective Veye width time	B1&B2	-	0.25	-	-	UI	Fig. 2
Modulation Ratio of SSC	Vspread	@100KHz	-	-	2	%	1
1 <sup>st</sup> data to SOE rising time	Ts1	-	3	-	-	Packet	Fig.4
SOE rising to last data	Ts4	-	0	-	-	Packet	Fig.4
Last data to SOE falling	Ts5	-	10	-	-	Packet	Fig.4
EPI Bandwidth	BW	-	0.588	-	0.728	GBPS	

notes : 1. VModulation Ratio of SSC for 20KHz ~ 100kHz Modulation Frequency is calculated by  $(7 - 0.05 * F_{mod})$ , where  $F_{mod}$  unit is KHz.

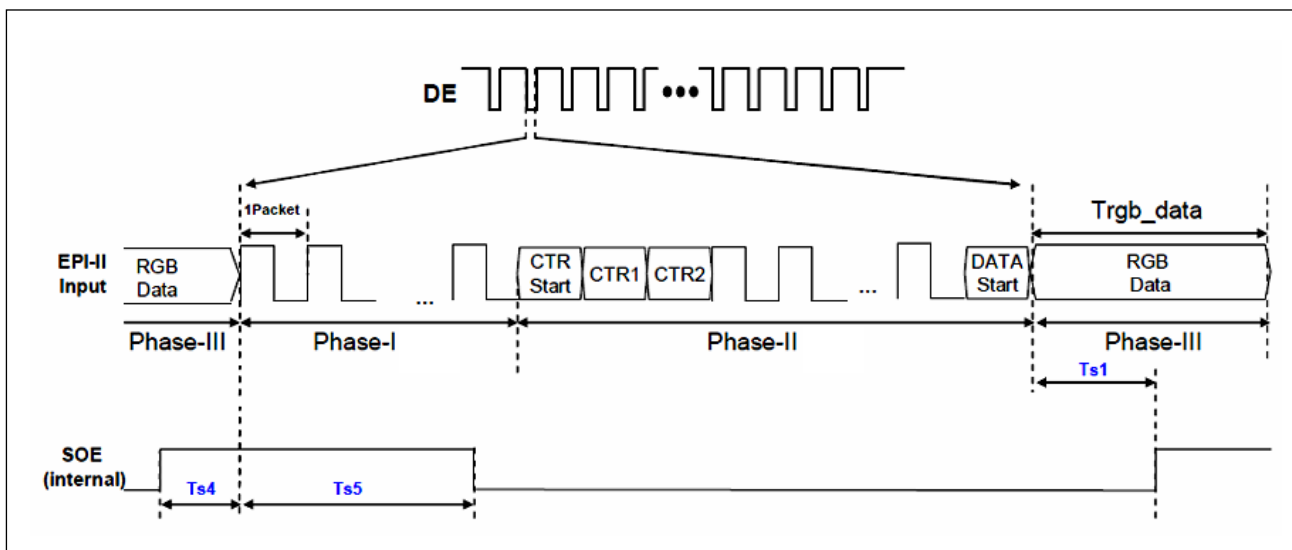

**FIG 4. SOE Width & Timing**

Product Specification

3-4. Panel Pixel Structure

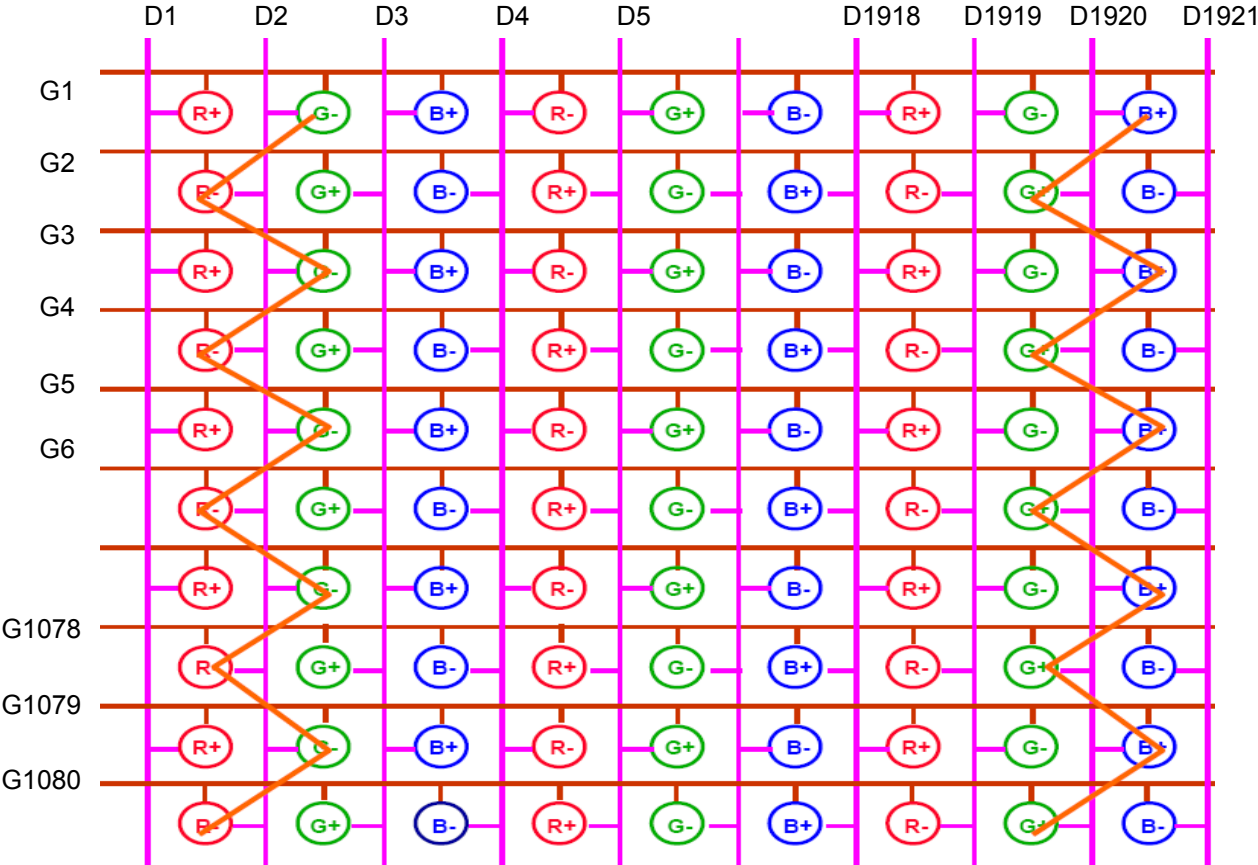

FIG. 5 Panel Pixel Structure

## Product Specification

## 3-5. Power Sequence

## 3-5-1. LCD Driving circuit

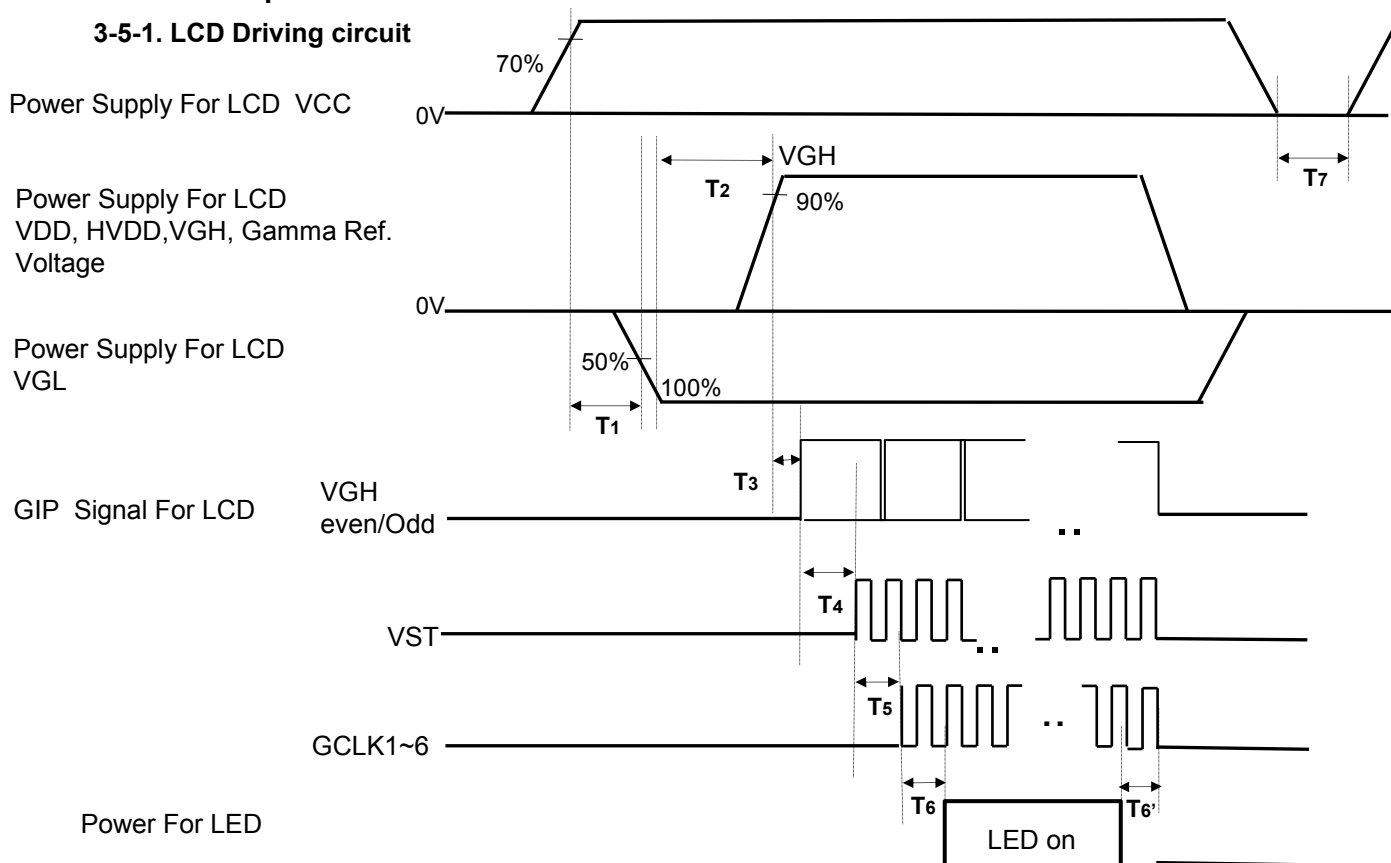

Table 6. POWER SEQUENCE

Ta= 25±2°C, fv=60Hz.

Parameter	Value			Unit	Notes
	Min	Typ	Max		
T1	0.5	-	-	ms	
T2	0.5	-	-	ms	
T3	0	-	-	ms	
T4	10	-	-	ms	2
T5	0	-	-	ms	
T6 / T6'	20	-	-	ms	6
T7	2	-	-	s	

- Note :
- Power sequence for Source D-IC must follow the Case1 & 2.  
※ Please refer to Appendix IV for more details.
  - VGH Odd signal should be started "High" status and VGH even & odd can not be "High at the same time.
  - Power Off Sequence order is reverse of Power On Condition including Source D-IC.
  - GCLK On/Off Sequence  
:GCLK3 → GCLK2 → GCLK1 → GCLK6 → GCLK5 → GCLK4.
  - VDD\_odd/even transition time should be within V\_blank
  - In case of T6', If there is no abnormal display, no problem

## Product Specification

## 4. Optical Specification

Optical characteristics are determined after the unit has been 'ON' and stable in a dark environment at  $25\pm 2^{\circ}\text{C}$ . The values are specified at distance 50cm from the LCD surface at a viewing angle of  $\Phi$  and  $\theta$  equal to  $0^{\circ}$ . FIG.6 shows additional information concerning the measurement equipment and method.

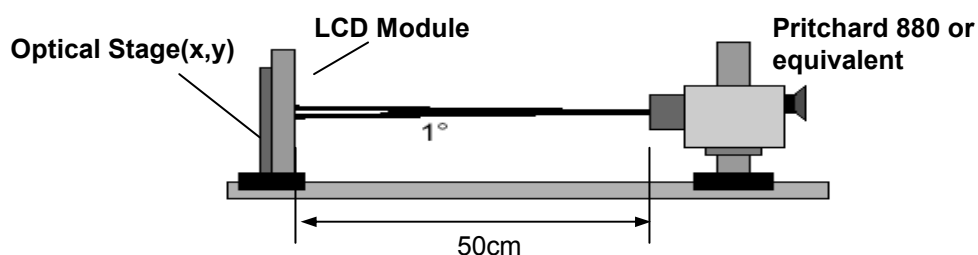

FIG. 6 Optical Characteristic Measurement Equipment and Method

Table 7. OPTICAL CHARACTERISTICS

$T_a = 25\pm 2^{\circ}\text{C}$ , VDD,H\_VDD,VGH,VGL=typ,  
fV=60Hz, BW=0.693GBPS, IF = 150mA

Parameter	Symbol	Value			Unit	Note		
		Min	Typ	Max				
Contrast Ratio	CR	900	1300	-		1		
Surface Luminance, white	$L_{WH}$	2D	320	400		cd/m <sup>2</sup>	2	
		3D	120	150			7	
Luminance Variation	$\delta_{WHITE}$	9P	60	70	%	3		
Response Time	Rising	$T_f$	-	8	12	ms	4	
	Falling	$T_f$	-	10	14			
Color Coordinates [CIE1931]	RED	Rx	Typ -0.03	0.641	Typ +0.03			
		Ry		0.335				
	GREEN	Gx		0.310				
		Gy		0.604				
	BLUE	Bx		0.156				
		By		0.055				
WHITE	Wx	0.281						
	Wy	0.288						
Color Temperature			10,000		K			
Color Gamut				68	%			
Viewing Angle	2D (CR>10)	right( $\phi=0^{\circ}$ )	$\theta_r$ (x axis)	89	-	-	degree	5
		left ( $\phi=180^{\circ}$ )	$\theta_l$ (x axis)	89	-	-		
		up ( $\phi=90^{\circ}$ )	$\theta_u$ (y axis)	89	-	-		
		down ( $\phi=270^{\circ}$ )	$\theta_d$ (y axis)	89	-	-		
	3D (CT $\leq$ 10%)	up + down	$\theta_u$ (y axis) + $\theta_d$ (y axis)	16	20	-		7
		up	$\theta_u$ (y axis)	5				
down	$\theta_d$ (y axis)	5						
3D Crosstalk		3D C/T	-	1	3	%		
Gray Scale			-	-	-		6	

## Product Specification

Note : 1. Contrast Ratio(CR) is defined mathematically as :

$$\text{Contrast Ratio} = \frac{\text{Surface Luminance with all white pixels}}{\text{Surface Luminance with all black pixels}}$$

It is measured at center 1-point.

2. Surface luminance is determined after the unit has been 'ON' and 1 Hour after lighting the backlight in a dark environment at  $25 \pm 2^\circ\text{C}$ . Surface luminance is the luminance value at center 1-point across the LCD surface 50cm from the surface with all pixels displaying white. For more information see the FIG. 6.
3. The variation in surface luminance,  $\delta$  WHITE is defined as :  
 $\delta$  WHITE(9P) = Minimum (Lon1,Lon2~ Lon8, Lon9) / Maximum (Lon1,Lon2~ Lon8, Lon9)\*100  
 Where Lon1 to Lon9 are the luminance with all pixels displaying white at 9 locations  
 For more information, see the FIG. 7.
4. Response time is the time required for the display to transit from G(0) to G(255) (Rising Time, Tr) and from G(255) to G(0) (Falling Time, Tf). For additional information, see the FIG. 8.
5. Viewing angle is the angle at which the contrast ratio is greater than 10. The angles are determined for the horizontal or x axis and the vertical or y axis with respect to the z axis which is normal to the LCD module surface. For more information, see the FIG. 9.
6. Gray scale specification  
 Gamma Value is approximately 2.2. For more information, see the Table 8.
7. 3D performance specification is expressed by 3D luminance, 3D Crosstalk and 3D viewing angle.  
 3D luminance and 3D crosstalk is measured at center 1-point.  
 For more information, see the FIG 10~13.

**Table 8. GRAY SCALE SPECIFICATION**

Gray Level	Luminance [%] (Typ)
L0	0.07
L15	0.28
L31	1.05
L47	2.50
L63	4.69
L79	7.67
L95	11.47
L111	16.11
L127	21.64
L143	28.07
L159	35.43
L175	43.73
L191	52.99
L207	63.23
L223	74.47
L239	86.72
L255	100

	Gray Level	Gamma Ref.
Positive Voltage	L0	Gamma9
	L31	Gamma7
	L63	Gamma5
	L127	Gamma4
	L191	Gamma3
	L255	Gamma1
Negative Voltage	L255	Gamma18
	L191	Gamma16
	L127	Gamma15
	L63	Gamma14
	L31	Gamma12
	L0	Gamma10



## Product Specification

Measuring point for surface luminance & measuring point for luminance variation.

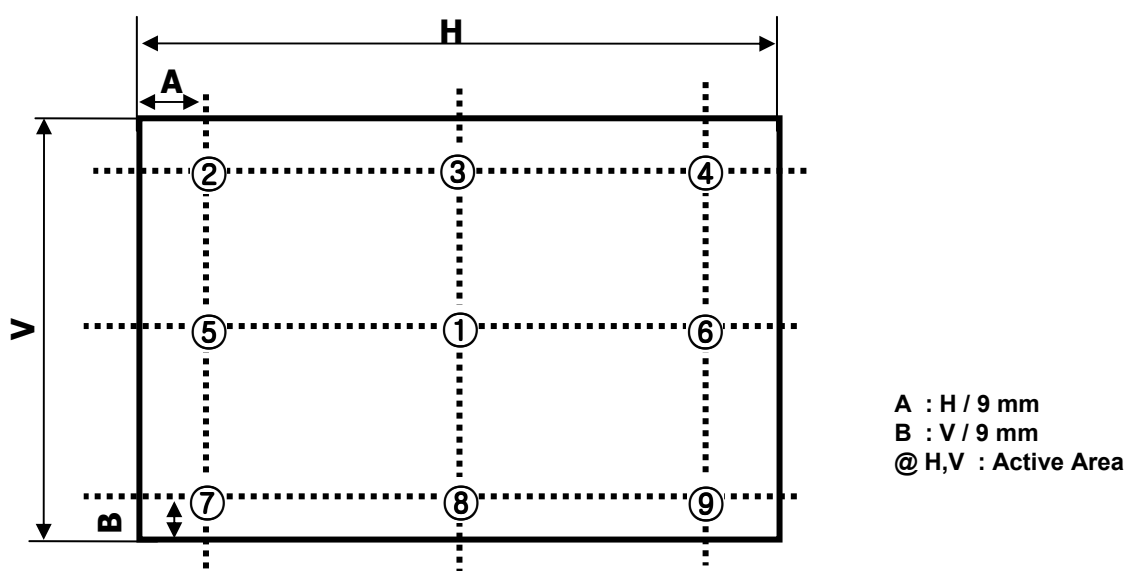

FIG. 7 9 Points for Luminance Measure

Response time is defined as the following figure and shall be measured by switching the input signal for "Black(G0)" ~ "White(G255)" and "White(G0)" ~ "Black(G255)".

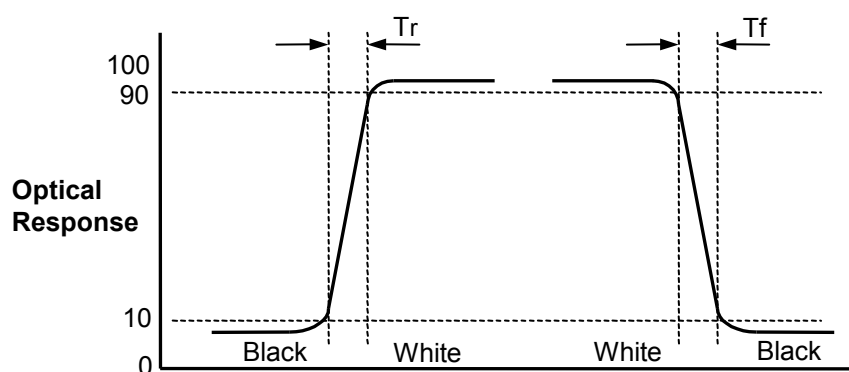

FIG. 8 Response Time

## Product Specification

Dimension of viewing angle range

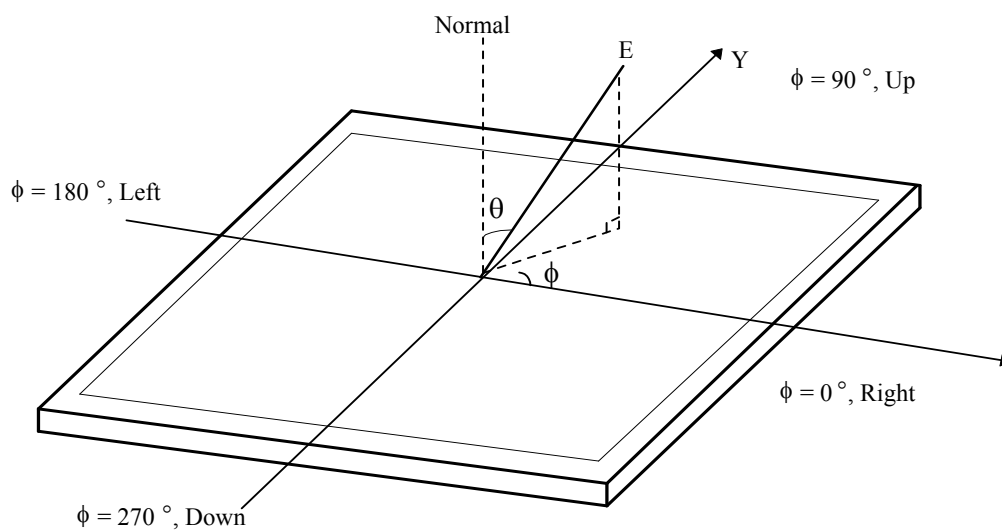
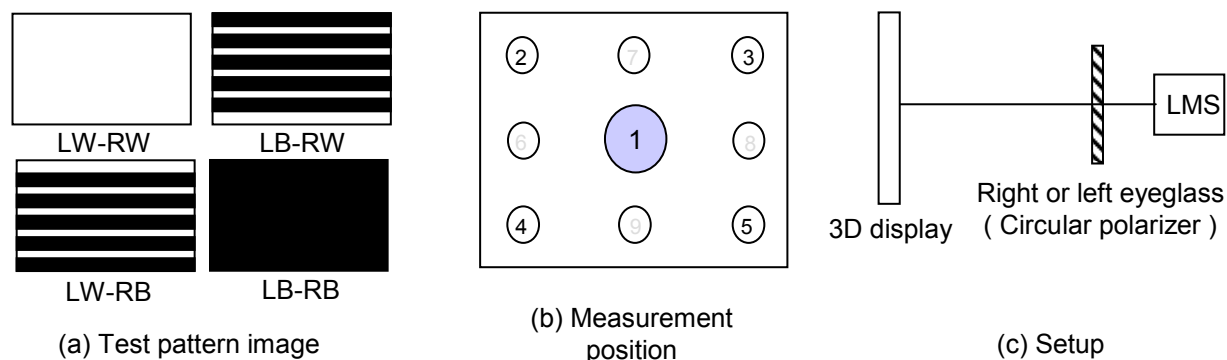
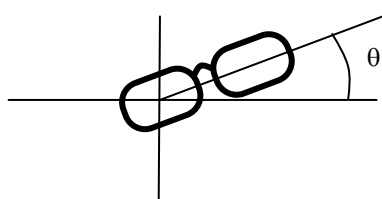

FIG. 9 Viewing Angle

## Product Specification



&lt; FIG.10. Measurement configuration &gt;



&lt; FIG.11. Positioning eyeglass &gt;

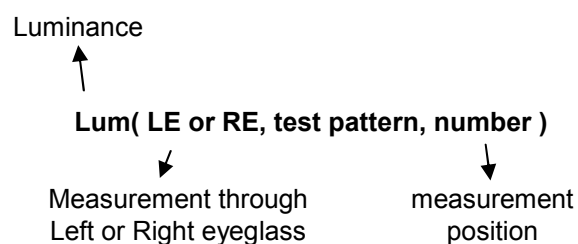

&lt; FIG. 12. notation of luminance measurement &gt;

In order to measure 3D luminance, 3D crosstalk and 3D viewing angle, it need to be prepared as below;

## 1) Measurement configuration

4-Test pattern images. Refer to FIG 10.

- LW-RW : White for left and right eye
- LW-RB : White for left eye and Black for right eye
- LB-RW : Black for left eye and white for right eye
- LB-RB : Black for left eye and right eye

Image files where black and white lines are displayed on even or odd lines.

Luminance measurement system (LMS) with narrow FOV (field of view) is used. Refer to FIG 6.

## 2) Positioning Eyeglass (refer to appendix-VIII for standard specification of eyeglass)

Find angle of minimum transmittance.

This value would be provided beforehand or measured by the following steps;

- (i) Test image (LB-RW) is displayed.
- (ii) Left eyeglass are placed in front of LMS and luminance is measured, rotating right eyeglass such as FIG 7. The notation for luminance measurement is "Lum(LE, LB-RW,1)".
- (iii) Find the angle where luminance is minimum.

\* Following measurements should be performed at the angle of minimum transmittance of eyeglass.

## Product Specification

## 3) Measurement of 3D luminance

- (i) Test image ( LW-RW ) is displayed.
- (ii) Left or right eyeglass are placed in front of LMS successively and luminance is measured at center 1 point where the notation for luminance measurement is "Lum(LE, LW-RW,1)" or "Lum(RE, LW-RW,1).

## 4) Measurement of 3D crosstalk

- (i) Test image ( LB-RW, LW-RB and LB-RB ) is displayed.
- (ii) Right or left eyeglass are placed in front of LMS successively and luminance is measured for position 1. with rotating LMS or sample vertically.

$$\frac{\text{Lum}(\text{LE}, \text{LB-RW}, 1) - \text{Lum}(\text{LE}, \text{LB-RB}, 1)}{\text{Lum}(\text{LE}, \text{LW-RB}, 1) - \text{Lum}(\text{LE}, \text{LB-RB}, 1)}$$

or

$$\frac{\text{Lum}(\text{RE}, \text{LW-RB}, 1) - \text{Lum}(\text{RE}, \text{LB-RB}, 1)}{\text{Lum}(\text{RE}, \text{LB-RW}, 1) - \text{Lum}(\text{RE}, \text{LB-RB}, 1)}$$

## 5) Measurement of 3D Viewing Angle

3D viewing angle is the angle at which the 3D crosstalk is under 10%. The angles are determined for the vertical or y axis with respect to the z axis which is normal to the LCD module surface and measured for position 1. For more information , see the Fig 13

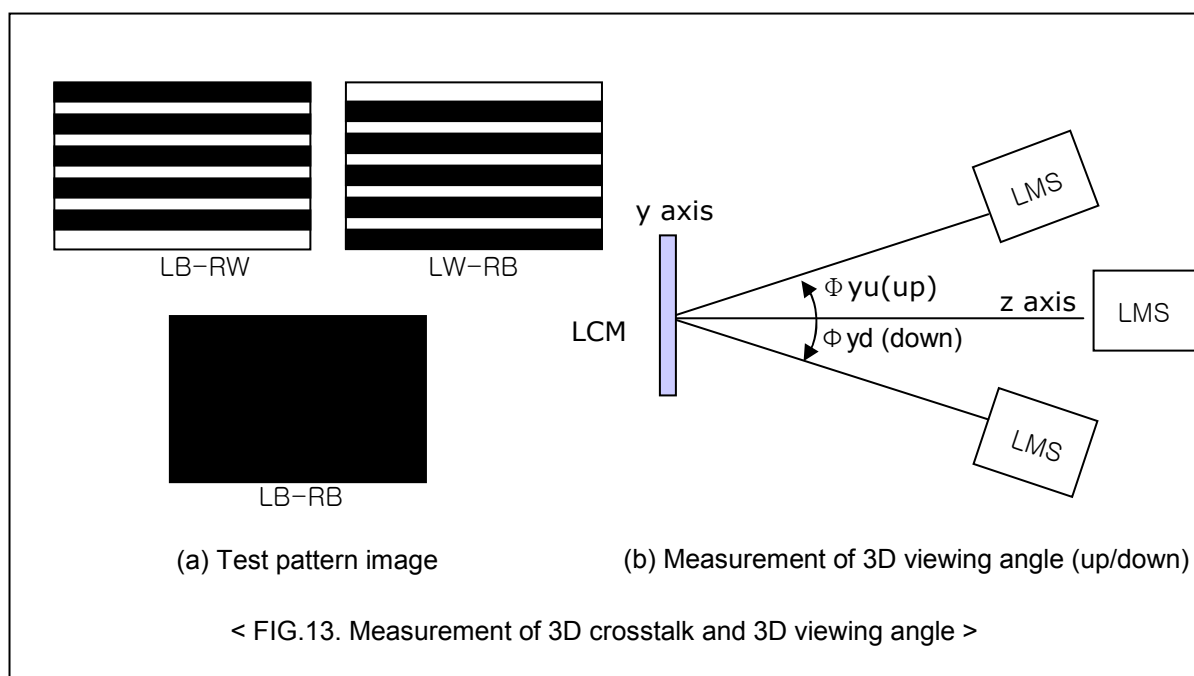

## Product Specification

**5. Mechanical Characteristics**

Table 9 provides general mechanical characteristics.

**Table 9. MECHANICAL CHARACTERISTICS**

Item	Value	
Outline Dimension	Horizontal	1229.4 mm
	Vertical	706.3 mm
	Depth	9.9 mm
Bezel Area	Horizontal	1229.4 mm
	Vertical	695.1 mm
Active Display Area	Horizontal	1209.6 mm
	Vertical	680.4 mm
Weight	15.0Kg (Typ.), 15.8kg (Max.)	

Note : Please refer to a mechanical drawing in terms of tolerance at the next page.  
Outline dimension values are included side sealing thickness.

Product Specification

[ FRONT VIEW ]

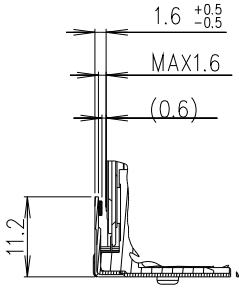
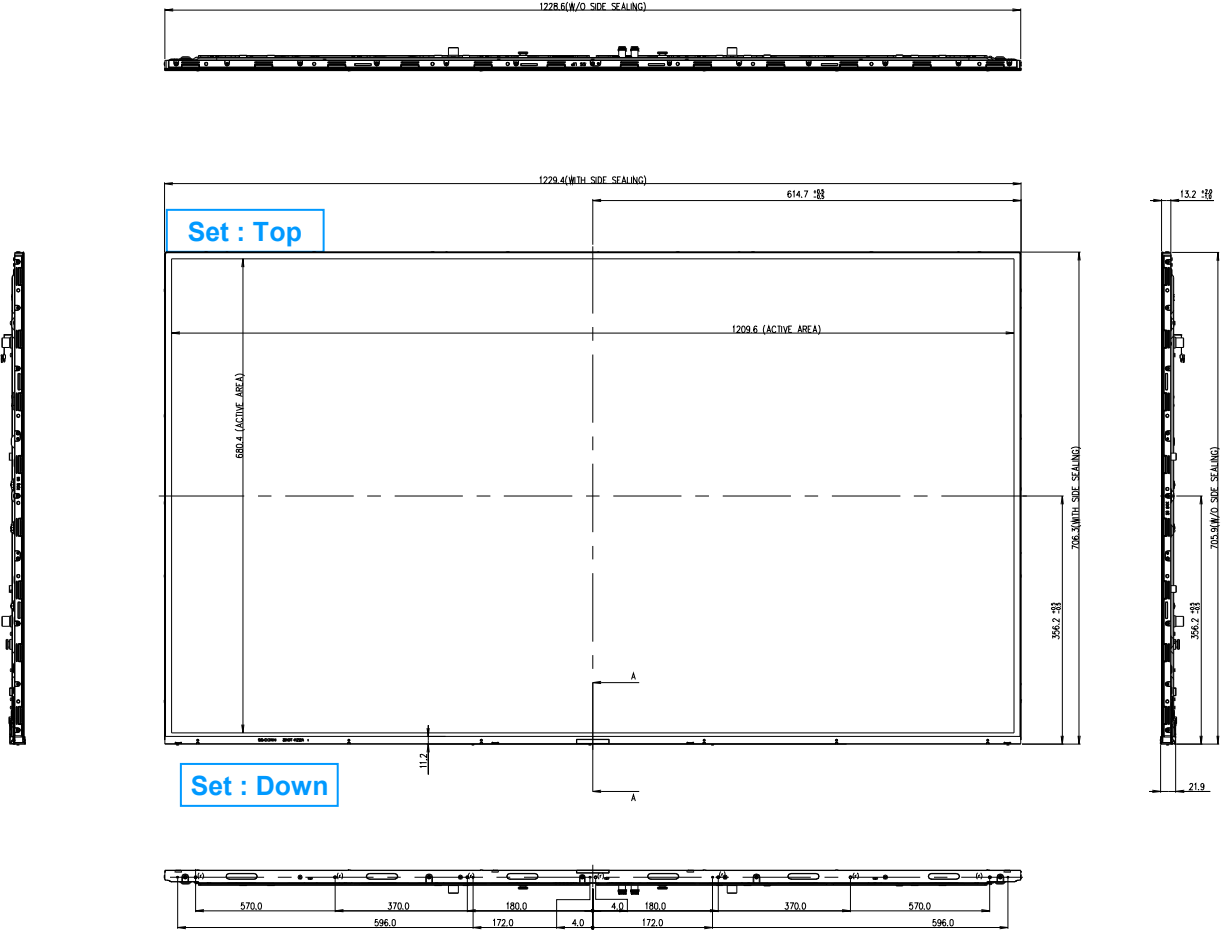

SECTION A-A  
SCALE 1/1

- NOTES
1. UNSPECIFIED TOLERANCE IS ±1.0MM
  2. MAX. TORQUE : REFER TO TABLE
  3. MAX. DEPTH (SCREW) : REFER TO TABLE
  4. THE SAME FEATURE MEANS THE SAME DIMENSION

Product Specification

[ REAR VIEW ]

Set : Top

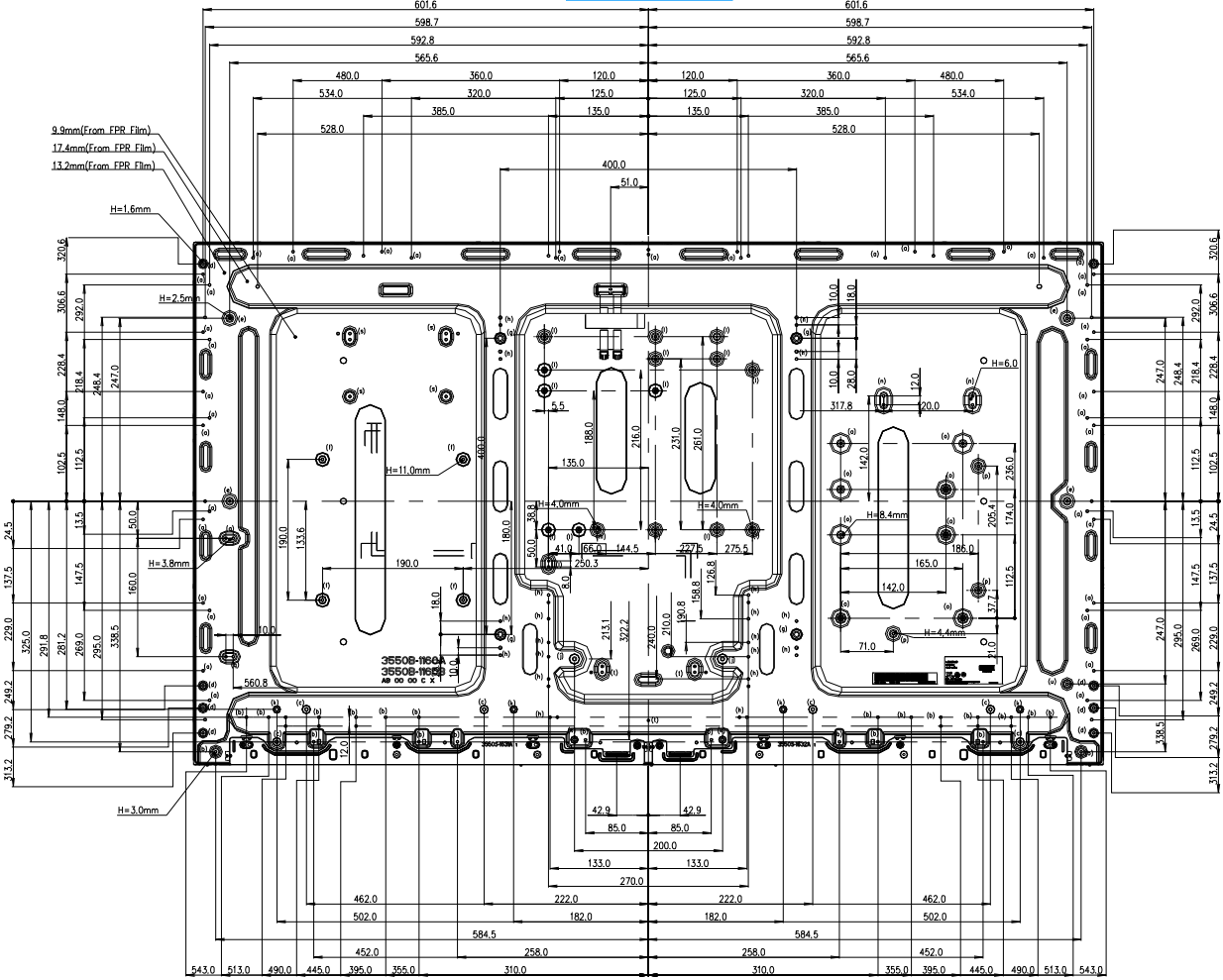

Set : Down

ITEM	TAP	Max Depth (mm)	Torque (xg.cm)	Notes
(a)	M3.0	3.5	Max 8.0	
(b)	M3.0	3.2	Max 8.0	
(c)	M4.0	5.0	Max 10.0	
(d)	M3.0	5.1	Max 8.0	
(e)	M3.0	7.8	Max 8.0	
(f)	M3.0	11.0	Max 8.0	
(g)	M6.0	13.0	Max 15.0	
(h)	M3.0	6.8	Max 8.0	
(j)	M4.0	8.5	Max 10.0	
(k)	M4.0	6.5	Max 10.0	
(l)	M3.0	4.3	Max 8.0	
(m)	M4.0	4.3	Max 10.0	
(n)	M3.0	6.0	Max 8.0	
(o)	M3.0	8.4	Max 8.0	
(p)	M3.0	4.4	Max 8.0	
(q)	M3.0	5.8	Max 8.0	
(r)	M3.0	3.5	Max 8.0	
(s)	M3.0	2.4	Max 8.0	
(t)	M2.6	4.0	Max 8.0	
(u)	M3.0	5.8	Max 8.0	

## Product Specification

## 6. Reliability

Table 10. ENVIRONMENT TEST CONDITION

No.	Test Item	Condition
1	High temperature storage test	Ta= 60°C 240h
2	Low temperature storage test	Ta= -20°C 240h
3	High temperature operation test	Ta= 50°C 50%RH 240h
4	Low temperature operation test	Ta= 0°C 240h
5	Vibration test (non-operating)	No Guarantee
6	Shock test (non-operating)	No Guarantee
7	Panel Push Test (Module Condition)	Max 6kgf (Test Method : Note 2)
8	Humidity condition Operation	Ta= 40 °C ,90%RH
9	Altitude operating storage / shipment	0 - 16,400 ft 0 - 40,000 ft

Note 1 : Before and after Reliability test, LCM should be operated with normal function.

Note 2 : Panel Push Test Method

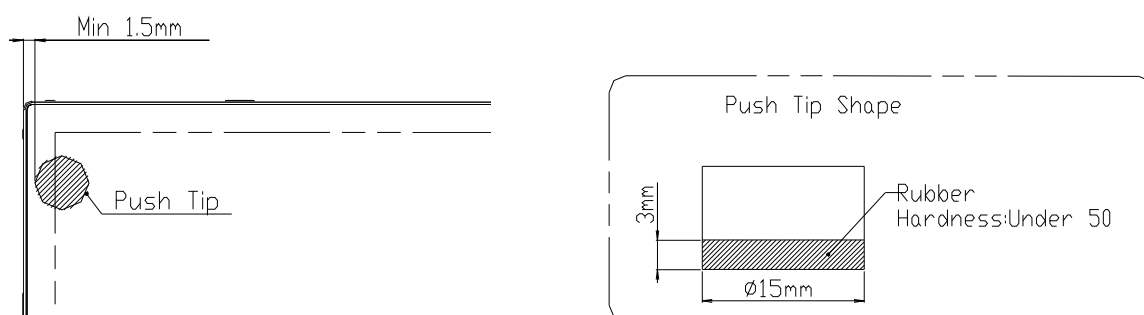



## 7. International Standards

### 7-1. Safety

- a) UL 60065, Underwriters Laboratories Inc.  
Audio, Video and Similar Electronic Apparatus - Safety Requirements.
- b) CAN/CSA C22.2 No.60065:03, Canadian Standards Association.  
Audio, Video and Similar Electronic Apparatus - Safety Requirements.
- c) EN 60065, European Committee for Electrotechnical Standardization (CENELEC).  
Audio, Video and Similar Electronic Apparatus - Safety Requirements.
- d) IEC 60065, The International Electrotechnical Commission (IEC).  
Audio, Video and Similar Electronic Apparatus - Safety Requirements.  
(Including report of IEC60825-1:2001 clause 8 and clause 9)

#### Notes

##### 1. Laser (LED Backlight) Information

Class 1M LED Product IEC60825-1 : 2001 Embedded LED Power (Class 1)
---

##### 2. Caution

- : LED inside.
- Class 1M laser (LEDs) radiation when open.
- Do not open while operating.

### 7-2. EMC

- a) ANSI C63.4 "American National Standard for Methods of Measurement of Radio-Noise Emissions from Low-Voltage Electrical and Electronic Equipment in the Range of 9 kHz to 40 GHz." American National Standards Institute (ANSI), 2003.
- b) CISPR 22 "Information technology equipment – Radio disturbance characteristics – Limit and methods of measurement." International Special Committee on Radio Interference (CISPR), 2005.
- c) CISPR 13 "Sound and television broadcast receivers and associated equipment – Radio disturbance characteristics – Limits and method of measurement." International Special Committee on Radio Interference (CISPR), 2006.

### 7-3. Environment

- a) RoHS, Directive 2002/95/EC of the European Parliament and of the council of 27 January 2003

## Product Specification

**8. Packing****8-1. Information of LCM Label**

a) Lot Mark

A	B	C	D	E	F	G	H	I	J	K	L	M
---	---	---	---	---	---	---	---	---	---	---	---	---

A,B,C : SIZE(INCH)  
E : MONTH

D : YEAR  
F ~ M : SERIAL NO.

Note

## 1. YEAR

Year	2011	2012	2013	2014	2015	2016	2017	2018	2019	2020
Mark	A	B	C	D	E	F	G	H	J	K

## 2. MONTH

Month	Jan	Feb	Mar	Apr	May	Jun	Jul	Aug	Sep	Oct	Nov	Dec
Mark	1	2	3	4	5	6	7	8	9	A	B	C

b) Location of Lot Mark

Serial NO. is printed on the label. The label is attached to the backside of the LCD module.  
This is subject to change without prior notice.

**8-2. Packing Form**

a) Package quantity in one Pallet : 16 pcs

b) Pallet Size : 1440 mm(W) X 1140 mm(D) X 950 mm(H)

## 9. Precautions

Please pay attention to the followings when you use this TFT LCD module.

### 9-1. Mounting Precautions

- (1) You must mount a module using specified mounting holes (Details refer to the drawings).
- (2) You should consider the mounting structure so that uneven force (ex. Twisted stress) is not applied to the module. And the case on which a module is mounted should have sufficient strength so that external force is not transmitted directly to the module.
- (3) Please attach the surface transparent protective plate to the surface in order to protect the polarizer. Transparent protective plate should have sufficient strength in order to resist external force.
- (4) You should adopt radiation structure to satisfy the temperature specification.
- (5) Acetic acid type and chlorine type materials for the cover case are not desirable because the former generates corrosive gas of attacking the polarizer at high temperature and the latter causes circuit break by electro-chemical reaction.
- (6) Do not touch, push or rub the exposed polarizers with glass, tweezers or anything harder than HB pencil lead. And please do not rub with dust clothes with chemical treatment. Do not touch the surface of polarizer for bare hand or greasy cloth. (Some cosmetics are detrimental to the polarizer.)
- (7) When the surface becomes dusty, please wipe gently with absorbent cotton or other soft materials like chamois soaks with petroleum benzene. Normal-hexane is recommended for cleaning the adhesives used to attach front / rear polarizers. Do not use acetone, toluene and alcohol because they cause chemical damage to the polarizer
- (8) Wipe off saliva or water drops as soon as possible. Their long time contact with polarizer causes deformations and color fading.
- (9) Do not open the case because inside circuits do not have sufficient strength.

### 9-2. Operating Precautions

- (1) Response time depends on the temperature. (In lower temperature, it becomes longer.)
- (2) Brightness depends on the temperature. (In lower temperature, it becomes lower.)  
And in lower temperature, response time (required time that brightness is stable after turned on) becomes longer
- (3) Be careful for condensation at sudden temperature change. Condensation makes damage to polarizer or electrical contacted parts. And after fading condensation, smear or spot will occur.
- (4) When fixed patterns are displayed for a long time, remnant image is likely to occur.
- (5) Module has high frequency circuits. Sufficient suppression to the electromagnetic interference shall be done by system manufacturers. Grounding and shielding methods may be important to minimize the interference.
- (6) Please do not give any mechanical and/or acoustical impact to LCM. Otherwise, LCM can't be operated its full characteristics perfectly.
- (7) A screw which is fastened up the steels should be a machine screw.  
(if not, it can cause conductive particles and deal LCM a fatal blow)
- (8) Please do not set LCD on its edge.

### 9-3. Electrostatic Discharge Control

Since a module is composed of electronic circuits, it is not strong to electrostatic discharge. Make certain that treatment persons are connected to ground through wrist band etc. And don't touch interface pin directly.

### 9-4. Precautions for Strong Light Exposure

Strong light exposure causes degradation of polarizer and color filter.

### 9-5. Storage

When storing modules as spares for a long time, the following precautions are necessary.

- (1) Store them in a dark place. Do not expose the module to sunlight or fluorescent light. Keep the temperature between 5°C and 35°C at normal humidity.
- (2) The polarizer surface should not come in contact with any other object.  
It is recommended that they be stored in the container in which they were shipped.
- (3) Storage condition is guaranteed under packing conditions.
- (4) The phase transition of Liquid Crystal in the condition of the low or high storage temperature will be recovered when the LCD module returns to the normal condition

### 9-6. Operating condition guide

- (1) The LCD product should be operated under normal conditions. Normal condition is defined as below;
  - Temperature : 5 ~ 40 °C, normal humidity.
  - Display pattern : continually changing pattern (Not stationary)
- (2) If the product will be used in extreme conditions such as high temperature, display patterns or operation time etc.,  
It is strongly recommended to contact LGD for Qualification engineering advice. Otherwise, its reliability and function may not be guaranteed. Extreme conditions are commonly found at Airports, Transit Stations, Banks, Stock market, and Controlling systems. The LCD product should be applied by global standard environment. (refer ETSI EN 300, IEC 60721)

## Product Specification

## # APPENDIX-I

## ■ Pallet Ass'y

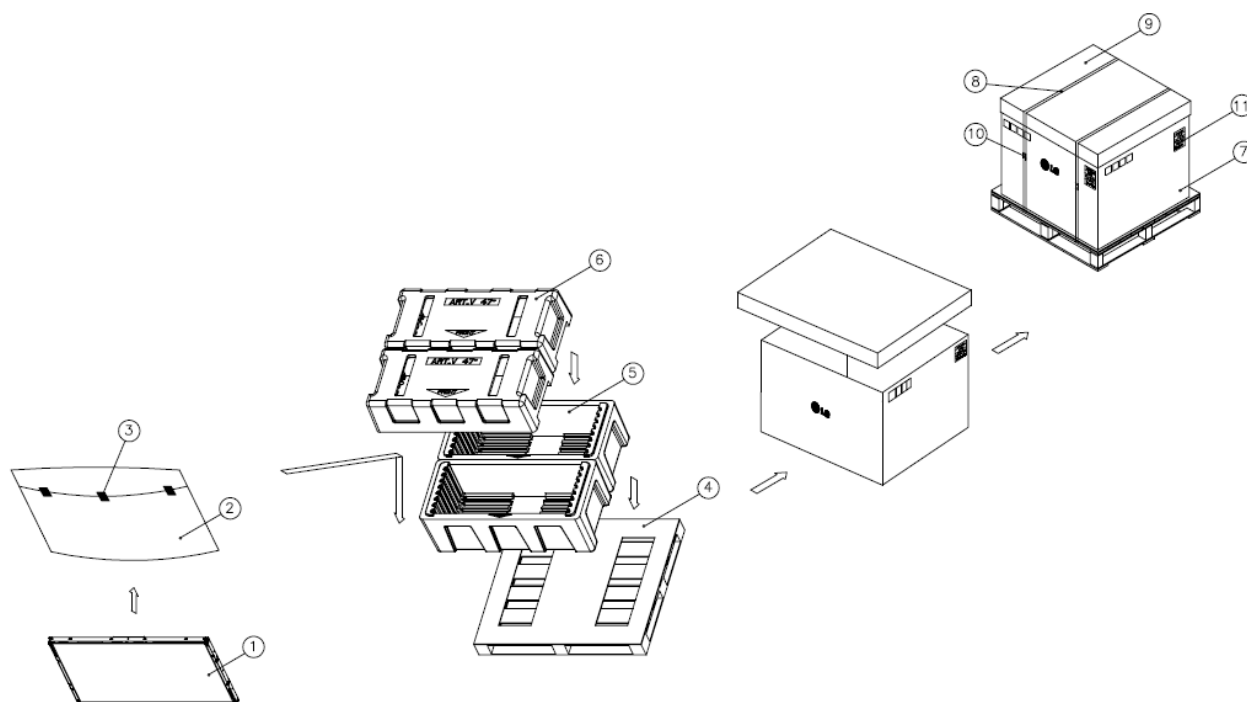

NO.	DESCRIPTION	MATERIAL
1	LCD Module	55" LCD
2	BAG	AL Bag
3	TAPE	MASKING 20MMX50M
4	PALLET	Plywood 1440X1140X125.5mm
5	PACKING,BOTTOM	EPS
6	PACKING, TOP	EPS
7	ANGLE,PACKING	PAPER
8	BAND	PP
9	ANGLE,COVER	PAPER
10	BAND	STEEL OR PP
11	LABEL	YUPO 80G 100X70

Product Specification

# APPENDIX- II-1

■ LCM Label



■ Production site

- LG Display (Paju) Co., LTD
- LG Display (Guangzhou) Co., LTD

Note 1.The origin of LCM Label will be changed according to the production site.

Product Specification

# APPENDIX- II-2

■ Pallet Label

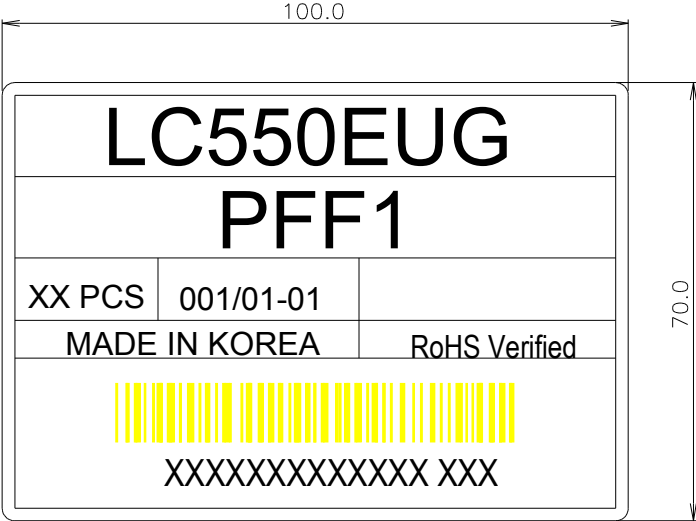

## Product Specification

## # APPENDIX-III

## ■ LED Array Electrical Spec

Ta = 25°C

Parameter	Condition	Min	Typ	Max	Unit	Remark
Forward voltage*1 ( $V_{Fm}$ )		75	81.25	87.5	V	Ta=25°C
$\Delta V_F^{*2}$				1.7	V	CASE ii

\*1 Previously stated VF can be assured under the condition of IF variation  $\pm 5\%$

\*2 CASE i) Model with driver

(Delta VF between 2 Bar is not required, except String in 1bar ought to satisfy 1.7 V.)

CASE ii) Model without driver

(Delta Vf 1.7 V between 2 Bar should be satisfied.)

CASE iii) Model without driver

(Delta VF between 2 Bar is not required, except String in 1bar ought to satisfy 0.5 V.)

## ■ Forward Current vs. Forward Voltage

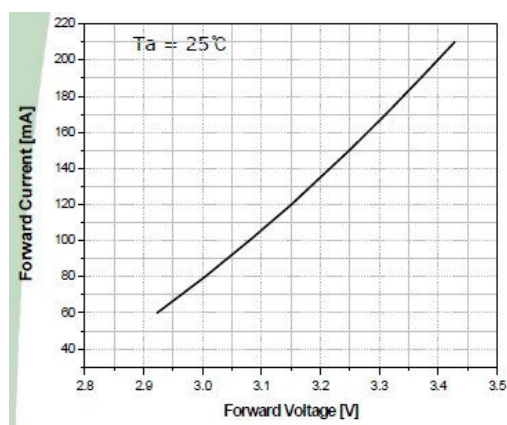

## ■ Ambient Temperature vs. Forward Voltage

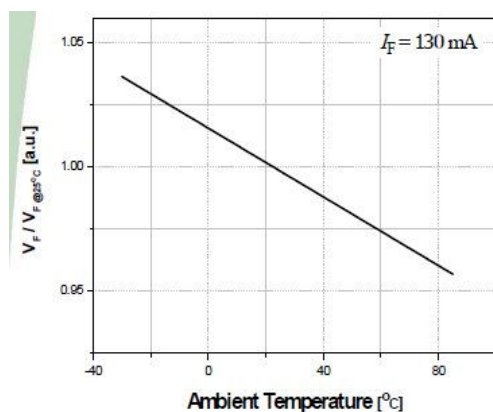



Product Specification

# APPENDIX- IV

■ Source D-IC Power Sequence

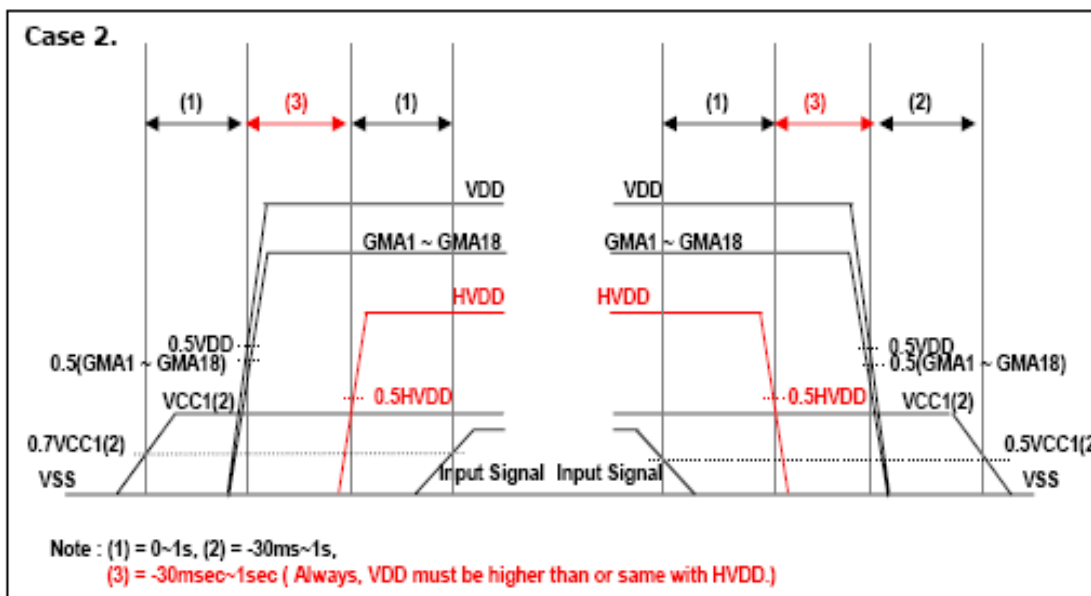
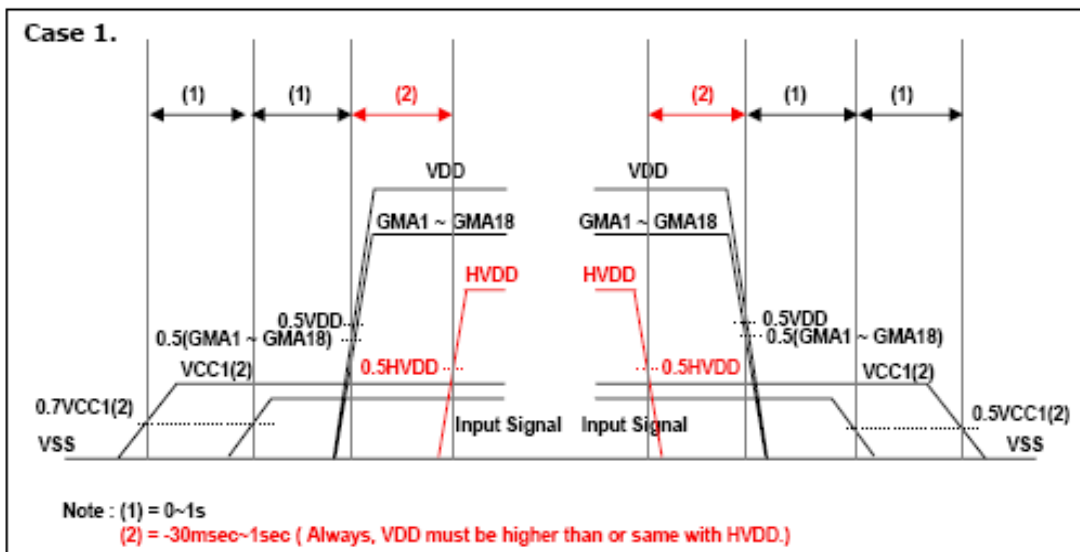

- Input Signal : EPI

Product Specification

# APPENDIX-V

Local Dimming Block Pin Matching

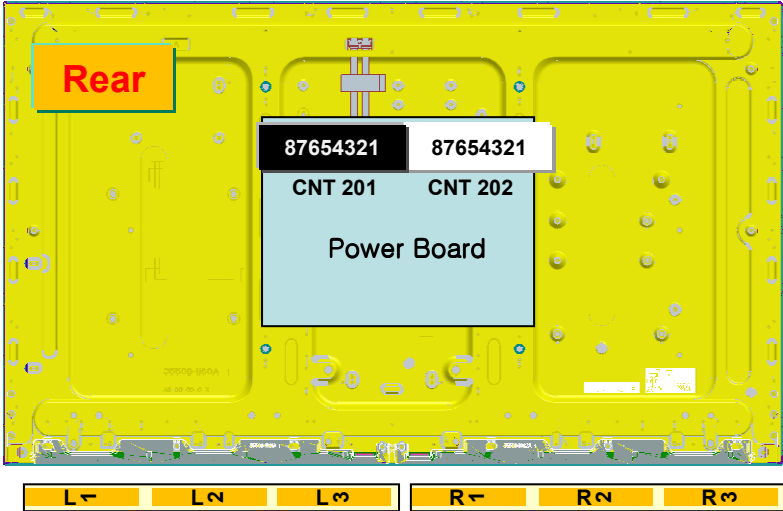

LED Driver CNT		
Pin No	L_CNT (8pin)	R_CNT (8pin)
1	L1 Cathode	Anode_R
2	L2 Cathode	N.C
3	L3 Cathode	N.C
4	N.C	N.C
5	N.C	N.C
6	N.C	R1 Cathode
7	N.C	R2 Cathode
8	Anode_L	R3 Cathode

Product Specification

# APPENDIX-VI

■ EPI Input Protocol

1. Clock Training Pattern input mode

. Clock Training Pattern (Phase I )

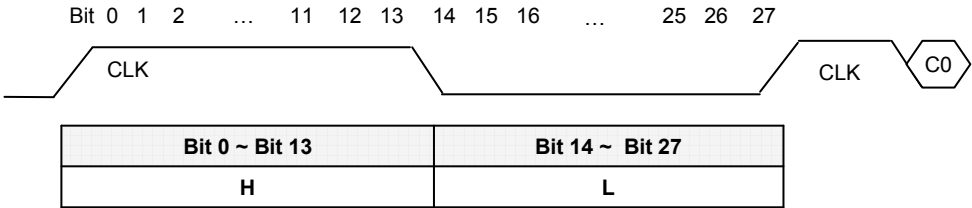

2. Control Signal input mode

.Control Data (Phase II)

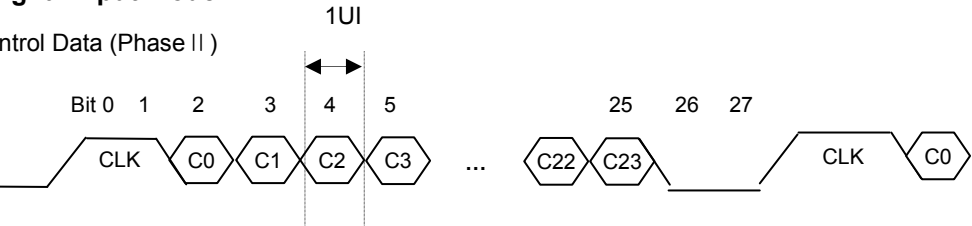

Bit 0	Bit 1	Bit 2 ~ 25	Bit 26	Bit 27
H	H	Control Data	L	L

3. Display Data input mode

. RGB Data (Phase III)

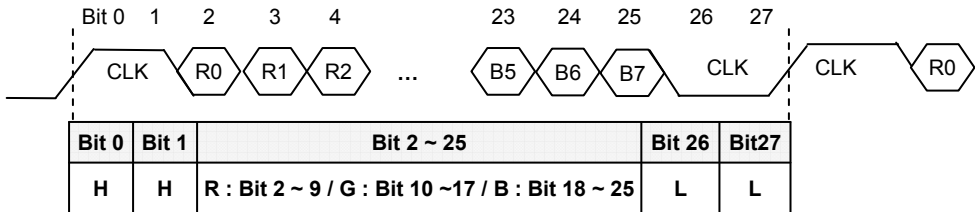

## Product Specification

## # APPENDIX- VII

## ■ Standard specification of Eyeglasses

This is recommended data of Eyeglasses for LC550EUG-PFF1 model. (details refer to table)

For each item, depending on the eyeglass manufacturer tolerances may occur, this tolerance can affect 3D performance. (3D Crosstalk, 3D luminance, 3D viewing angle)

<Table. Standard specification of Eyeglasses>

Design item of Eyeglasses		Left	Right	Remark
Optical axis	a) Slow axis of retarder	-45°	45°	Refer to drawing
	b) Transmission axis of polarizer	0°	0°	
Retardation value	Retarder	125nm		@550nm

※ Recommended polarizer

Polarization efficiency: more than 99.90%

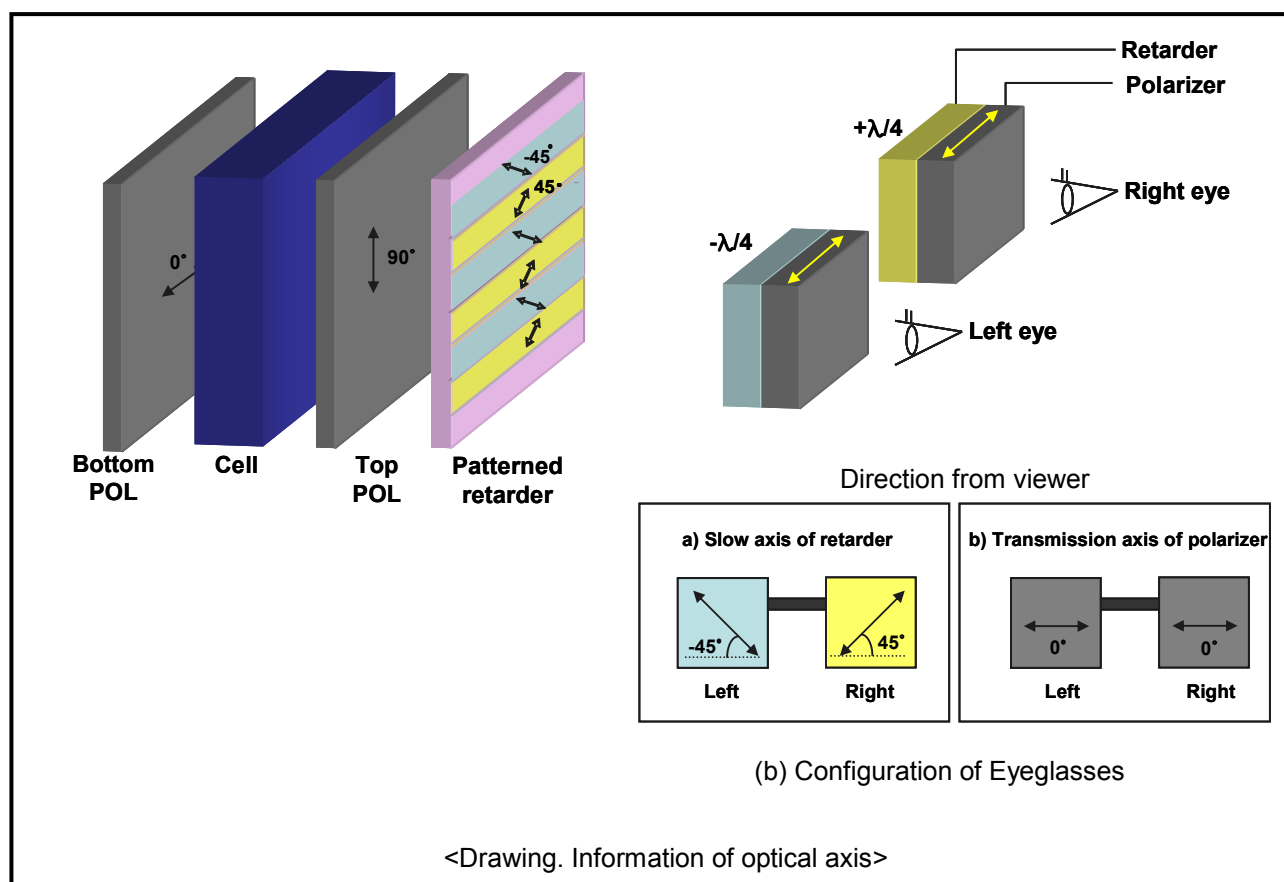

## # APPENDIX-VIII

### ■ Management for Micro-crack by Laser Cutting

#### 1. Subject of process : Laser cutting

#### 2. Measuring cycle

- Regular measuring : One of Fixer Ass'Y is measured in every 8 hours
- Irregular measuring : One of Fixer Ass'Y is measured when a model is changed

#### 3. Measurement Method

- Measuring point : 9 Points

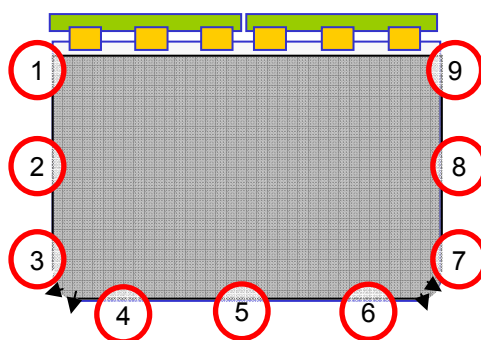

- Measuring Condition

- Magnification of microscope : 50 times
- Lighting Mode : Reflection Mode

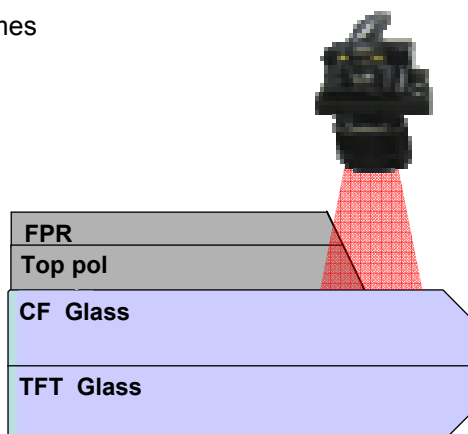

#### 4. Management standard

- Micro-crack length : Smaller than  $50\mu\text{m}$  at Start①/End⑨ point, no micro-crack at the rest of point