

LC709301F

Switching Charge/Discharge Controller for 1-Cell Li-Ion Battery

Features

- 10 x / 20 x Amplifier
- 8/10-bit High-speed PWM (150 kHz)
- Reference Voltage Generator Circuit (2 V / 4 V) for an AD Converter
- Temperature Sensor
- Internal Reset Circuit
- 8-Channel AD Converter with 12-/8-bit Resolution Selector
- Internal Oscillation Circuits (30 kHz / 1 MHz / 8 MHz)

Performance

- 83.3 ns (12.0 MHz) $V_{DD} = 2.7\text{ V to }5.5\text{ V}$ $T_a = -40^\circ\text{C to }+85^\circ\text{C}$
- 125 ns (8.0 MHz) $V_{DD} = 2.0\text{ V to }5.5\text{ V}$ $T_a = -40^\circ\text{C to }+85^\circ\text{C}$
- 250 ns (4.0 MHz) $V_{DD} = 1.8\text{ V to }5.5\text{ V}$ $T_a = -40^\circ\text{C to }+85^\circ\text{C}$

Function Descriptions

- Ports
 - ◆ I/O Ports :18
 - ◆ Reference Voltage Outputs: 1 (VREF)
 - ◆ Power Supply Pin : 3 (V_{SS1} , V_{SS2} , V_{DD1})
- Timers (3ch)
 - ◆ Timer 0 : 16-bit Timer/Counter with a Capture Register
 - ◆ Timer 1 : 16-bit Timer/Counter that Supports PWM/Toggle Outputs
 - ◆ Base Timer Serving as a Realtime Clock
- SIO (1ch)
 - ◆ SIO1: 8-bit Asynchronous/Synchronous Serial Interface
- Comparator
- Watchdog Timer
- Frequency Tunable 12-bit PWM x 2ch
- System Clock Divider Function
- 15 sources, 10 Vectors Interrupts
- On-chip Debugger Function

Application

- Battery Charge/Discharge Control (E-cigarette)



ON Semiconductor®

www.onsemi.com

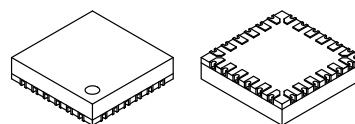

VCT24 3.5x3.5, 0.5P
CASE 601AD

MARKING DIAGRAM



XXXXXX = Specific Device Code
Y = Year
M = Month
DD / DDD = Additional Traceability Data

*This information is generic. Please refer to device data sheet for actual part marking. Pb-Free indicator, "G" or microdot "▪", may or may not be present.

PIN ASSIGNMENT

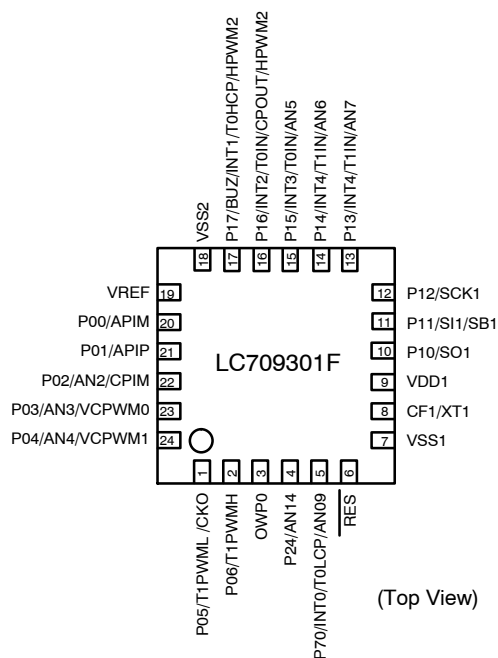

*This product is licensed from Silicon Storage Technology, Inc. (USA).

ORDERING INFORMATION

See detailed ordering and shipping information on page 23 of this data sheet.

Function Details

Flash ROM

- Capable of on-board programming with a wide range of supply voltages: 2.2 to 5.5 V
- Block-erasable in 128 byte units
- Writes data in 2-byte units
- 8192 x 8 bits

RAM

- 256 x 9 bits

Bus Cycle Time

- 83.3 ns (12 MHz, $V_{DD} = 2.7\text{ V to }5.5\text{ V}$, $T_a = -40^\circ\text{C to }85^\circ\text{C}$)
- 125 ns (8 MHz, $V_{DD} = 2.0\text{ V to }5.5\text{ V}$, $T_a = -40^\circ\text{C to }85^\circ\text{C}$)
- 250 ns (4 MHz, $V_{DD} = 1.8\text{ V to }5.5\text{ V}$, $T_a = -40^\circ\text{C to }85^\circ\text{C}$)

NOTE: The bus cycle time here refers to the ROM read speed.

Minimum Instruction Cycle Time (t_{CYC})

- 250 ns (12 MHz, $V_{DD} = 2.7\text{ V to }5.5\text{ V}$, $T_a = -40^\circ\text{C to }85^\circ\text{C}$)
- 375 ns (8 MHz, $V_{DD} = 2.0\text{ V to }5.5\text{ V}$, $T_a = -40^\circ\text{C to }85^\circ\text{C}$)
- 750 ns (4 MHz, $V_{DD} = 1.8\text{ V to }5.5\text{ V}$, $T_a = -40^\circ\text{C to }85^\circ\text{C}$)

Potrs

- Normal withstand voltage I/O ports whose I/O direction can be designated in 1-bit units

	18 (P0n, P1n, P24, P70, CF1)
--	------------------------------
- Reset pins 1 ($\overline{\text{RES}}$)
- Power supply pins 3 (V_{SS1} , V_{SS2} , V_{DD1})
- Reference voltage outputs 1 (VREF)
- Dedicated debugger port 1 (OWP0)

Timers

- Timer 0: 16-bit timer/counter with 2 capture registers.
 - Mode 0: 8-bit timer with an 8-bit programmable prescaler (with two 8-bit capture registers) x 2 channels
 - Mode 1: 8-bit timer with an 8-bit programmable prescaler (with two 8-bit capture registers) + 8-bit counter (with two 8-bit capture registers)
 - Mode 2: 16-bit timer with an 8-bit programmable prescaler (with two 16-bit capture registers)
 - Mode 3: 16-bit counter (with two 16-bit capture registers)
- Timer 1: 16-bit timer/counter that supports PWM/toggle outputs
 - Mode 0: 8-bit timer with an 8-bit prescaler (with toggle outputs) + 8-bit timer/counter with an 8-bit prescaler (with toggle outputs)
 - Mode 1: 8-bit PWM with an 8-bit prescaler x 2 channels

Mode 2: 16-bit timer/counter with an 8-bit prescaler (with toggle outputs) (toggle outputs also possible from lower-order 8 bits)

Mode 3: 16-bit timer with an 8-bit prescaler (with toggle outputs) (lower-order 8 bits may be used as a PWM output)

- Base timer
 1. The clock is selectable from the low speed RC, system clock, and timer 0 prescaler output.
 2. with an 8-bit programmable prescaler
 3. Interrupts programmable in 5 different time schemes

SIO

- SIO1: 8-bit asynchronous/synchronous serial interface
 - Mode 0: Synchronous 8-bit serial I/O (2- or 3-wire configuration, 2 to 512 t_{CYC} transfer clocks)
 - Mode 1: Asynchronous serial I/O (half-duplex, 8 data bits, 1 stop bit, 8 to 2048 t_{CYC} baudrates)
 - Mode 2: Bus mode 1 (start bit, 8 data bits, 2 to 512 t_{CYC} transfer clocks)
 - Mode 3: Bus mode 2 (start detect, 8 data bits, stop detect)

AD Converter

- AD converter input port with 10 x /20 x amplifier (1 channel)
- AD converter input port (8 channel) 12-/8-bit resolution selectable AD converter
- Selectable reference voltage source for an AD converter (Selectable from V_{DD} , Internal Reference Voltage Generator Circuit (VREF))

Internal Reference Voltage Generator Circuit (VREF)

- Generates 2.0 V/4.0 V for AD converter.

Comparator

- Comparator input pin (1 channel)
- Comparator output pin (1 channel)
- Comparator output set high when (comparator input level) $< 1.22\text{ V}$
- Comparator output set low when (comparator input level) $> 1.22\text{ V}$

Clock Output Function

- Generates clocks with a clock rate of 1/1, 1/2, 1/4, 1/8, 1/16, 1/32, or 1/64 of the source oscillation clock that is selected as the system clock.

Watchdog Timer

- Generates an internal reset on an overflow occurring in the timer running on the low-speed RC oscillator clock (approx. 30 kHz).
- Operating mode at standby is selectable from 3 modes (continue counting/suspend operation/suspend counting with the count value retained)

Interrupts

- 15 sources, 10 vectors
 1. Provides three levels (low (L), high (H), and highest (X)) of multiplex interrupt control. Any interrupt requests of the level equal to or lower than the current interrupt are not accepted.
 2. When interrupt requests to two or more vector addresses occur at the same time, the interrupt of the highest level takes precedence over the other interrupts. For interrupts of the same level, the interrupt into the smallest vector address is given priority.

No.	Vector Address	Level	Interrupt Source
1	00003H	X or L	INT0
2	0000BH	X or L	INT1
3	00013H	H or L	INT2/T0L/INT4
4	0001BH	H or L	INT3/BT
5	00023H	H or L	T0H
6	0002BH	H or L	T1L/T1H
7	00033H	H or L	HPWM2
8	0003BH	H or L	SIO1
9	00043H	H or L	ADC
10	0004BH	H or L	P0/VCPWM

- Priority levels X > H > L
- Of interrupts of the same level, the one with the smallest vector address takes precedence.

Subroutine Stack Levels

Up to 128levels (the stack is allocated in RAM.)

High-speed Multiplication/Division Instructions

- 16 bits x 8 bits (5 tCYC execution time)
- 24 bits x 16 bits (12 tCYC execution time)
- 16 bits ÷ 8 bits (8 tCYC execution time)
- 24 bits ÷ 16 bits (12 tCYC execution time)

Oscillation Circuits

- Internal oscillation circuits
 1. Low-speed RC oscillation circuit:
For system clock (approx.30 kHz)
 2. Medium-speed RC oscillation circuit:
For system clock (1 MHz)
 3. Hi-speed RC oscillation circuit1:
For system clock (8 MHz)
 4. Hi-speed RC oscillation circuit2:
For High speed PWM (40 MHz)

System Clock Divider Function

- Can run on low consumption current
- Minimum instruction cycle selectable from 375 ns, 750 ns, 1.5 μs, 3.0 μs, 6.0 μs, 12.0 μs, 24.0 μs, 48.0 μs, and 96.0 μs (at 8 MHz main clock)

Internal Reset Circuit

- Power-on reset (POR) function
 1. POR reset is generated only at power-on time.
 2. The POR release level is 1.67 V.
- Low-voltage detection reset (LVD) function
 1. LVD and POR functions are combined to generate resets when power is turned on and when power voltage falls below a certain level.
 2. The use/disuse of the LVD function and the low voltage threshold level can be selected from 7 levels (1.91 V, 2.01 V, 2.31 V, 2.51 V, 2.81 V, 3.79 V and 4.28 V), through option configuration.

Standby Function

- HALT mode: Halts instruction execution while allowing the peripheral circuits to continue operation.
 1. Oscillation is not halted automatically.
 2. There are three ways of resetting the HALT mode.
 - (1) Setting the reset pin to the low level
 - (2) Having the watchdog timer or LVD function generate a reset
 - (3) Having an interrupt generated
- HOLD mode: Suspends instruction execution and the operation of the peripheral circuits.
 1. The low-speed, medium-speed, and high-speed RC oscillators automatically stop operation.
NOTE:The low-speed RC oscillator is controlled directly by the watchdog timer; its oscillation in the standby mode is also controlled by the watchdog timer.
 2. There are four ways of resetting the HOLD mode:
 - (1) Setting the reset pin to the lower level
 - (2) Having the watchdog timer or LVD function generate a reset
 - (3) Having an interrupt source established at one of the INT0, INT1, INT2 and INT4 pins
* INT0 and INT1 can be used in the level sense mode only.
 - (4) Having an interrupt source established at port 0.

LC709301F

- X'tal HOLD mode: Suspends instruction execution and the operation of the peripheral circuits except the base timer (when low-speed RC oscillation is selected).

1. The low-speed, medium-speed, and high-speed RC oscillators automatically stop operation.

NOTE: The low-speed RC oscillator is controlled directly by the watchdog timer; its oscillation in the standby mode is also controlled by the watchdog timer.

NOTE: If the base timer is run with low-speed RC oscillation selected as the base timer input clock source and the X'tal HOLD mode is entered, the low-speed RC oscillator retains the state that is established when the X'tal HOLD mode is entered.

2. There are five ways of resetting the X'tal HOLD mode.
 - (1) Setting the reset pin to the low level
 - (2) Having the watchdog timer or LVD function generate a reset
 - (3) Having an interrupt source established at one of the INT0, INT1, INT2, and INT4 pins
 - * INT0 and INT1 can be used in the level sense mode only.
 - (4) Having an interrupt source established at port 0
 - (5) Having an interrupt source established in the base timer circuit

VCPWM

Frequency tunable 12-bit PWM x 2ch

High Speed PWM (HPWM2)

8-10- bits PWM x1ch

1. The PWM clock is selectable from system clock and Hi-speed RC2 (40 MHz)
2. The PWM type is selectable from 8 bits (Normal mode) and 10 bits (additive pulse mode).

Temperature Sensor

- Sensor voltage can be compared by the AD converter.

On-chip Debugger Function

- Supports software debugging with the IC mounted on the target board.
- Provides 1 channel of on-chip debugger pin. OWP0

Data Security Function

- Protects the program data stored in flash memory from unauthorized read or copy.

NOTE: This data security function does not necessarily provide absolute data security.

Package Form

- VCT24 (3.5 x 3.5): Lead-free and halogen-free type

Development Tools

- On-chip debugger: TCB87 Type C (1-wire interface cable) + LC709301F

Programming Boards

Package	Programming Boards
VCT24 (3.5 x 3.5)	W709301V-GMDT

FLASH PROGRAMMER

Maker		Model	Supported Version	Device
Flash Support Group Company (FSG)	Single Programmer	AF9711	Rev 03.28 or later	87F008SU
Flash Support Group Company (FSG) + ON Semiconductor (Note 1)	Onboard Single/Gang Programmer	AF9101/AF9103 (Main unit) (FSG models)	(Note 2)	-
		SIB87 Type C (Inter Face Driver) (Our company model)		
ON Semiconductor	Single/Gang Programmer	SKK Type B / SKK Type C	Application Version 1.08A or later Chip Data Version 2.52 or later	LC709301F
	Onboard Single/Gang Programmer	SKK-DBG Type C		

For information about AF-Series:
Flash Support Group Company (TOA ELECTRONICS, Inc.)
TEL: +81-53-459-1050
E-mail: sales@j-fsg.co.jp

1. On-board-programmer from FSG (AF9101/AF9103) and serial interface driver from ON Semiconductor. (SIB87 Type C) together can give a PC-less, standalone on-board-programming capabilities.
2. It needs a special programming devices and applications depending on the use of programming environment. Please ask FSG or our company for the information.

LC709301F

Pin Assignment

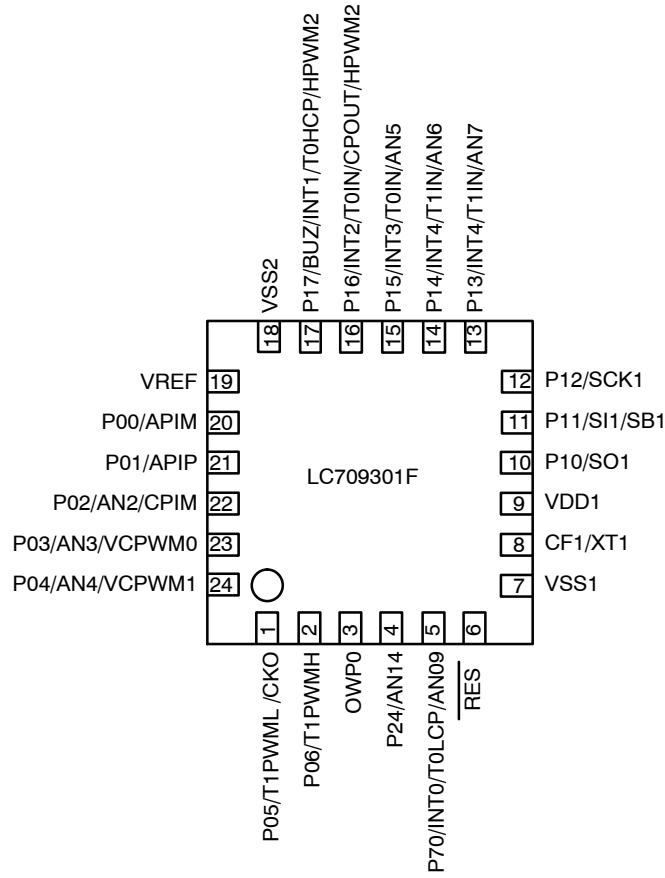

Figure 1. Top View
VCT24 (3.5 x 3.5) "Pb-Free / Halogen Free Type"

VCT24	NAME
1	P05/T1PWML/CKO
2	P06/T1PWMH
3	OWP0
4	P24/AN14
5	P70/INT0/T0LCP/AN09
6	RES
7	VSS1
8	CF1/XT1
9	VDD1
10	P10/SO1
11	P11/SI1/SB1
12	P12/SCK1

VCT24	NAME
13	P13/INT4/T1IN/AN7
14	P14/INT4/T1IN/AN6
15	P15/INT3/T0IN/AN5
16	P16/INT2/T0IN/CPOUT/HPWM2
17	P17/BUZ/INT1/T0HCP/HPWM2
18	VSS2
19	VREF
20	P00/APIP
21	P01/APIP
22	P02/AN2/CPIM
23	P03/AN3/VCPWM0
24	P04/AN4/VCPWM1

LC709301F

System Block Diagram

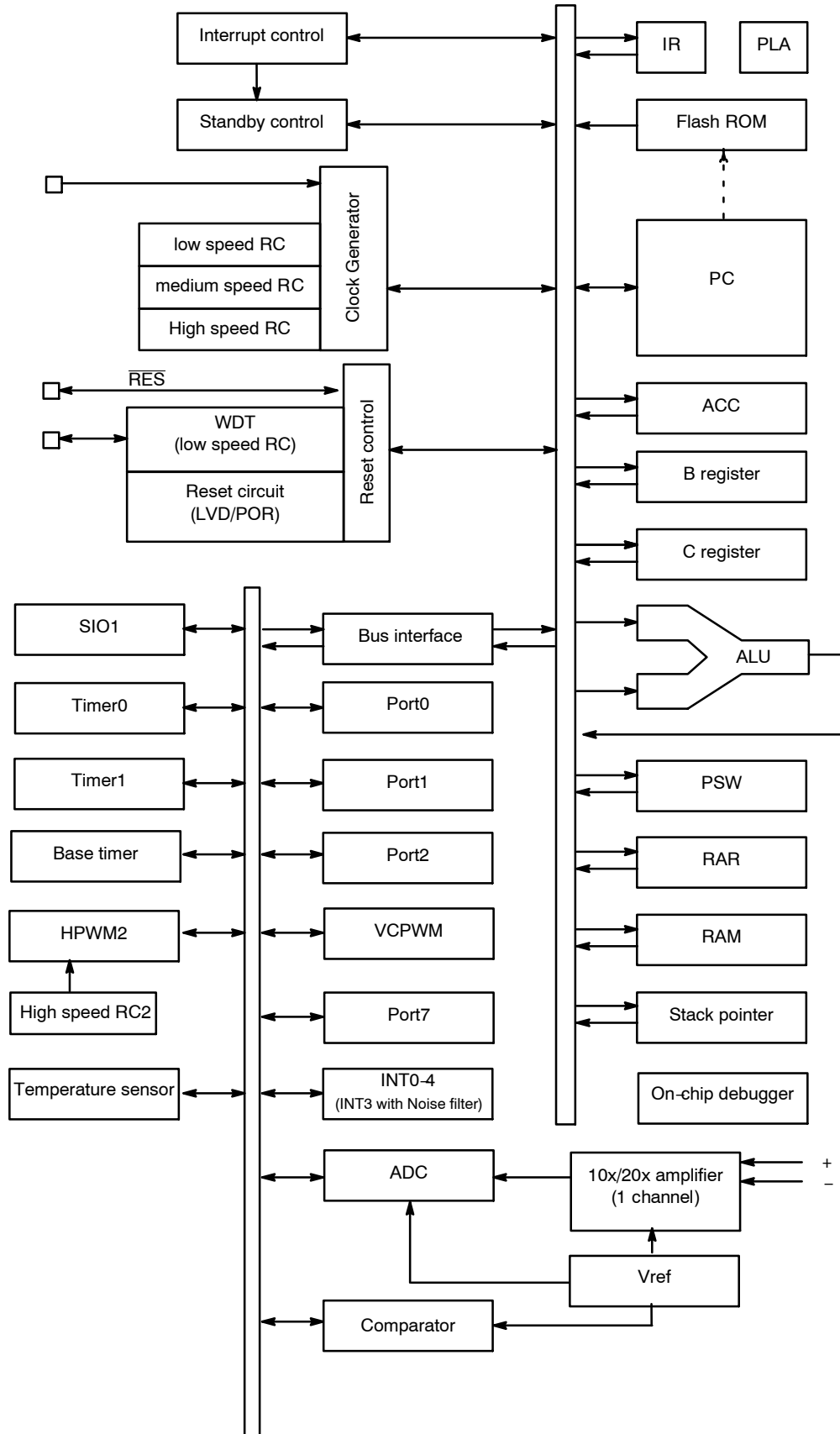

Figure 2. System Block Diagram

LC709301F

PIN DESCRIPTION

Pin Name	I/O	Description	Option																														
V _{SS1}	-	- power supply pin	No																														
V _{DD1}	-	+ power supply pin	No																														
V _{SS2}	-	- power supply pin	No																														
VREF	I/O	Reference voltage output (2.0 V / 4.0 V) or External input	No																														
Port 0	I/O	<ul style="list-style-type: none"> • 7-bit I/O port • I/O specifiable in 1-bit units. • Pull-up resistors can be turned on and off in 1-bit units. • Pin functions <ul style="list-style-type: none"> P00, P01: AD converter input port with 10x/20x operational amplifier P02: AD converter input port (AN2) / Comparator input (CPIM) P03: AD converter input port (AN3) / VCPWM0 output P04: AD converter input port (AN4) / VCPWM1 output P05: Timer 1 PWML output / System clock output P06: Timer 1 PWMH output P07: On-chip debugger pin (OWP0) 	Yes																														
P00 to P06																																	
Port 1	I/O	<ul style="list-style-type: none"> • 8-bit I/O port • I/O specifiable in 1-bit units. • Pull-up resistors can be turned on and off in 1-bit units. • Pin functions <ul style="list-style-type: none"> P10: SIO1 data output P11: SIO1 data input/bus input/output P12: SIO1 clock input/output P13: INT4 input/HOLD release input/timer 1 event input/timer 0L capture input/timer 0H capture input/AD converter input port (AN7) P14: INT4 input/HOLD release input/timer 1 event input/timer 0L capture input/timer 0H capture input/AD converter input port (AN6) P15: INT3 input (with noise filter)/timer 0 event input/timer 0H capture input/AD converter input port (AN5) P16: INT2 input/HOLD release input/timer 0 event input/timer 0L capture input/HPWM2 output P17: beeper output/INT1 input/HOLD release input/timer 0H capture input/HPWM2 output <p>Interrupt acknowledge type</p> <table border="1" style="width: 100%; border-collapse: collapse; text-align: center;"> <thead> <tr> <th></th> <th>Rising</th> <th>Falling</th> <th>Rising & Falling</th> <th>H level</th> <th>L level</th> </tr> </thead> <tbody> <tr> <td>INT1</td> <td>enable</td> <td>enable</td> <td>disable</td> <td>enable</td> <td>enable</td> </tr> <tr> <td>INT2</td> <td>enable</td> <td>enable</td> <td>enable</td> <td>disable</td> <td>disable</td> </tr> <tr> <td>INT3</td> <td>enable</td> <td>enable</td> <td>enable</td> <td>disable</td> <td>disable</td> </tr> <tr> <td>INT4</td> <td>enable</td> <td>enable</td> <td>enable</td> <td>disable</td> <td>disable</td> </tr> </tbody> </table>		Rising	Falling	Rising & Falling	H level	L level	INT1	enable	enable	disable	enable	enable	INT2	enable	enable	enable	disable	disable	INT3	enable	enable	enable	disable	disable	INT4	enable	enable	enable	disable	disable	Yes
	Rising		Falling	Rising & Falling	H level	L level																											
INT1	enable	enable	disable	enable	enable																												
INT2	enable	enable	enable	disable	disable																												
INT3	enable	enable	enable	disable	disable																												
INT4	enable	enable	enable	disable	disable																												
Port10 to P15																																	
Port 2	I/O	<ul style="list-style-type: none"> • 1-bit I/O port • I/O specifiable • Pull-up resistors can be turned on and off. • Pin functions <ul style="list-style-type: none"> P24: AD converter input port (AN14) 	Yes																														
P24																																	
Port 7	I/O	<ul style="list-style-type: none"> • 1-bit I/O port • I/O specifiable • Pull-up resistors can be turned on and off. • Pin functions <ul style="list-style-type: none"> P70: INT0 input/HOLD release input/timer 0L capture input/AD converter input port (AN9) <p>Interrupt acknowledge type</p> <table border="1" style="width: 100%; border-collapse: collapse; text-align: center;"> <thead> <tr> <th></th> <th>Rising</th> <th>Falling</th> <th>Rising & Falling</th> <th>H level</th> <th>L level</th> </tr> </thead> <tbody> <tr> <td>INT0</td> <td>enable</td> <td>enable</td> <td>disable</td> <td>enable</td> <td>enable</td> </tr> </tbody> </table>		Rising	Falling	Rising & Falling	H level	L level	INT0	enable	enable	disable	enable	enable	No																		
	Rising		Falling	Rising & Falling	H level	L level																											
INT0	enable	enable	disable	enable	enable																												
P70																																	

LC709301F

PIN DESCRIPTION (continued)

Pin Name	I/O	Description	Option
$\overline{\text{RES}}$	I	External reset input/internal reset output pin	Yes Internal pullup ON/OFF
CF1/XT1	I/O	<ul style="list-style-type: none"> • External system clock input Port • Pin functions • 1-bit I/O port • I/O specifiable (only Nch-open drain) 	No
OWP0	I/O	On-chip debugger pin	No

Port Output Types

The table below lists the types of port outputs and the presence/absence of a pull-up resistor.

Data can be read into any input port even if it is in the output mode.

PORT OUTPUT TYPES

Port Name	Option Selected in Units of	Option Type	Output Type	Pull-up Resistor
P00 to P06	1 bit	1	CMOS	Programmable
		2	Nch-open drain	Programmable
P10 to P17	1 bit	1	CMOS	Programmable
		2	Nch-open drain	Programmable
P24	1 bit	1	CMOS	Programmable
		2	Nch-open drain	Programmable
CF1/XT1	-	No	Nch-open drain when general I/O port is selected.	No
P70	-	No	Nch-open drain	Programmable

LC709301F

USER OPTION TABLE

Option Name	Option Type	Flash Version	Option Selected in Units of	Option Selection
Port output form	P00 to P06	enable	1 bit	CMOS
				Nch-open drain
	P10 to P17	enable	1 bit	CMOS
				Nch-open drain
	P24	enable	1 bit	CMOS
				Nch-open drain
Program start address	-	enable	-	00000h or 01E00h When protected area 1) is selected
				00000h When either of protected area 2), 3) or 4) is selected
Protected area (Note 3)	-	enable	-	1) 1800h-1FFFh
				2) 0000h-1DFFh, 1F00h-1FFFh
				3) 0000h-1CFFh, 1F00h-1FFFh
				4) 0000h-1AFFh, 1F00h-1FFFh
Reset pin	Internal pullup ON/OFF	enable	-	ON
				OFF
Low-voltage detection reset function	Detect function	enable	-	Enable: Use
				Disable: Not Used
	Detect level	enable	-	7-level
Power-on reset function	Power-On reset level	enable	-	1-level

3. Onboard programming inhibited address

RECOMMENDED UNUSED PIN CONNECTIONS

Port Name	Recommended Unused Pin Connections	
	Board	Software
P00 to P06	Open	Output low
P10 to P17	Open	Output low
P24	Open	Output low
P70	Open	Output low
CF1/XT1	Open	General I/O port output low
OWP0	Pulled low with a 100 kΩ resistor	-

LC709301F

On-chip Debugger Pin Connection Requirements

For the treatment of the on-chip debugger pins, refer to the separately available documents entitled “Rd87 On-chip Debugger Installation Manual”

Power Pin Treatment Recommendations (V_{DD1}, V_{SS1})

Connect bypass capacitors that meet the following conditions between the V_{DD1} and V_{SS1} pins:

- Connect among the V_{DD1} and V_{SS1} pins and bypass capacitors C1 and C2 with the shortest possible heavy lead wires, making sure that the impedances between the both pins and the bypass capacitors are as equal as possible (L1 = L1', L2 = L2').
- Connect a large-capacity capacitor C1 and a small-capacity capacitor C2 in parallel. The capacitance of C2 should be approximately 0.1 μF.

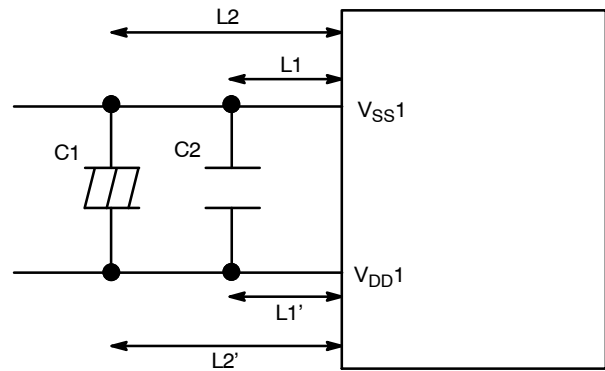

ABSOLUTE MAXIMUM RATINGS (Ta = 25°C, V_{SS1} = V_{SS2} = 0 V)

Parameter		Symbol	Pin/Remarks	Conditions	V _{DD} [V]	Specification			
						Min	Typ	Max	Unit
Maximum supply voltage		V _{DD} MAX	V _{DD1}		-	-0.3	to	+6.5	V
Input/output voltage		V _{IO}	Port0, 1, 2 Port7 CF1, RES		-	-0.3	to	V _{DD} +0.3	
High level output current	Peak output current	I _{OPH} (1)	Port0 Port1 Port2	<ul style="list-style-type: none"> • When CMOS output type is selected • Per 1 applicable pin 	-	-10	-	-	mA
	Average output current (Note 4)	I _{OMH} (1)	Port0 Port1 Port2	<ul style="list-style-type: none"> • When CMOS output type is selected • Per 1 applicable pin 	-	-7.5	-	-	
	Total output current	ΣI _{OAH} (1)	Port0, 1 Port2	Total current of all applicable pins	-	-30	-	-	
Low level output current	Peak output current	I _{OPL} (1)	Port0	• Per 1 applicable pin	-	-	-	20	
		I _{OPL} (2)	Port1	• Per 1 applicable pin	-	-	-	20	
		I _{OPL} (3)	Port2	• Per 1 applicable pin	-	-	-	20	
		I _{OPL} (4)	Port7, CF1	• Per 1 applicable pin	-	-	-	10	
	Average output current (Note 4)	I _{OML} (1)	Port0	• Per 1 applicable pin	-	-	-	15	
		I _{OML} (2)	Port1	• Per 1 applicable pin	-	-	-	15	
		I _{OML} (3)	Port2	• Per 1 applicable pin	-	-	-	15	
		I _{OML} (4)	Port7, CF1	• Per 1 applicable pin	-	-	-	7.5	
Total output current	ΣI _{OAL} (1)	Port0, 1, 2, 7, CF1	Total current of all applicable pins	-	-	-	80		
Allowable power Dissipation		P _{dmax} (1)	VCT24 (3.5 x 3.5)	Ta = -40 to +85°C Package with thermal resistance board (Note 5)	-	-	-	280	mW
Operating ambient Temperature		T _{opr}			-	-40	-	+85	°C
Storage ambient Temperature		T _{stg}			-	-55	-	+125	

Stresses exceeding those listed in the Maximum Ratings table may damage the device. If any of these limits are exceeded, device functionality should not be assumed, damage may occur and reliability may be affected.

4. The average output current is an average of current values measured over 100 ms intervals.

5. Thermal resistance board (size 40x50x0.85 mm, glass epoxy) is used.

LC709301F

ALLOWABLE OPERATING CONDITIONS (Ta = -40°C to +85°C, VSS1 = VSS2 = 0 V)

Parameter	Symbol	Pin/Remarks	Conditions	Specification				Unit
				VDD [V]	Min	Typ	Max	
Operating supply voltage (Note 6)	VDD(1)	VDD1	0.245 μs ≤ tCYC ≤ 200 μs	-	2.7	-	5.5	V
	VDD(2)		0.367 μs ≤ tCYC ≤ 200 μs	-	2.0	-	5.5	
	VDD(3)		0.735 μs ≤ tCYC ≤ 200 μs	-	1.8	-	5.5	
Memory sustaining supply voltage	VHD	VDD1	RAM and register contents sustained in HOLD mode.	-	1.6	-	-	
High level input voltage	VIH(1)	Port0, 1, 2 P70		1.8 to 5.5	0.3VDD +0.7	-	VDD	
	VIH(4)	CF1, RES		1.8 to 5.5	0.75VDD	-	VDD	
Low level input voltage	VIL(1)	Port0, 1, 2 P70		4.0 to 5.5	VSS	-	0.1VDD+0.4	
				1.8 to 4.0	VSS	-	0.2VDD	
	VIL(4)	CF1, RES		1.8 to 5.5	VSS	-	0.25VDD	
Instruction cycle time (Note 7)	tCYC (Note 7)			2.7 to 5.5	0.245	-	200	μs
				2.0 to 5.5	0.367	-	200	
				1.8 to 5.5	0.735	-	200	
External system clock frequency	FEXCF	CF1	<ul style="list-style-type: none"> System clock frequency division ratio=1/1 External system clock duty = 50 ±5% 	2.7 to 5.5	0.1	-	12	MHz
				2.2 to 5.5	0.1	-	8	
Oscillation frequency range	FmFRC(1)		Internal high-speed RC oscillation Ta = -10°C to +85°C (Note 8)	1.8 to 5.5	7.76	8.0	8.24	MHz
	FmFRC(2)		Internal high-speed RC oscillation Ta = -40°C to +85°C (Note 8)	1.8 to 5.5	7.60	8.0	8.40	
	FmRC		Internal medium-speed RC oscillation	1.8 to 5.5	0.5	1.0	2.0	
	FmSRC		Internal low-speed RC oscillation (Note 9)	1.8 to 5.5	27	30	33	kHz
	FmPWMRC		Internal high-speed RC oscillation for HPWM2	2.7 to 5.5	38	40	42	MHz
Oscillation Stabilization Time	TmsFRC (Note 8)		<ul style="list-style-type: none"> When oscillation circuit is switched from "oscillation stopped" to "oscillation enabled" . See Fig. 4. 	1.8 to 5.5	-	-	100	μs
	tmsPWMRC			1.8 to 5.5	-	-	100	
	tmsRC			1.8 to 5.5	-	0	-	
	TmsSRC (Note 9)			1.8 to 5.5	-	-	1	ms

Functional operation above the stresses listed in the Recommended Operating Ranges is not implied. Extended exposure to stresses beyond the Recommended Operating Ranges limits may affect device reliability.

6. VDD must be held greater than or equal to 2.7 V in the flash ROM onboard programming mode.

7. Relationship between tCYC and oscillation frequency is 3/FmCF at a division ratio of 1/1 and 6/FmCF at a division ratio of 1/2.

8. An oscillation stabilization time of 100 μs or longer must be provided before switching the system clock source after the state of the high-speed RC oscillation circuit is switched from "oscillation stopped" to "oscillation enabled" .

9. An oscillation stabilization time of 1ms or longer must be provided before switching the system clock source after the state of the low-speed RC oscillation circuit is switched from "oscillation stopped" to "oscillation enabled" .

LC709301F

ELECTRICAL CHARACTERISTICS (Ta = -40°C to +85°C, VSS1 = VSS2 = 0 V)

Parameter	Symbol	Pin/Remarks	Conditions	Specification				Unit
				V _{DD} [V]	Min	Typ	Max	
High level input current	I _{IH} (1)	Port0, 1, 2, Port7, RES	Output disabled Pull-up resistor off V _{IN} = V _{DD} (Including output Tr's off leakage current)	1.8 to 5.5	-	-	1	μA
	I _{IH} (2)	CF1	V _{IN} = V _{DD}	1.8 to 5.5	-	-	15	
Low level input current	I _{IL} (1)	Port0, 1, 2, Port7, RES	Output disabled Pull-up resistor off V _{IN} = V _{SS} (Including output Tr's off leakage current)	1.8 to 5.5	-1	-	-	
	I _{IL} (2)	CF1	V _{IN} = V _{SS}	1.8 to 5.5	-15	-	-	
High level output voltage	V _{OH} (1)	Port0, 1, 2	I _{OH} = -1 mA	4.5 to 5.5	V _{DD} -1	-	-	V
	V _{OH} (2)		I _{OH} = -0.2 mA	1.8 to 5.5	V _{DD} -0.4	-	-	
Low level output voltage	V _{OL} (1)	Port0, 1, 2, P70, CF1	I _{OL} = 10 mA	4.5 to 5.5	-	-	1.5	
	V _{OL} (2)		I _{OL} = 1.0 mA	1.8 to 5.5	-	-	0.4	
Pull-up resistance	R _{pu} (1)	Port0, 1, 2, P70	V _{OH} = 0.9 V _{DD}	4.5 to 5.5	15	35	80	kΩ
	R _{pu} (2)			1.8 to 4.5	18	50	230	
	R _{pu} (3)	RES		1.8 to 5.5	300	400	500	
Hysteresis voltage	V _{HYS} (1)	Port0, 1, 2, P70, RES		2.7 to 5.5	-	0.1V _{DD}	-	V
				1.8 to 5.5	-	0.07V _{DD}	-	
Pin capacitance	CP	All pins	For pins other than that under test: V _{IN} = V _{SS} , f = 1 MHz, Ta = 25°C	1.8 to 5.5	-	10	-	pF

Product parametric performance is indicated in the Electrical Characteristics for the listed test conditions, unless otherwise noted. Product performance may not be indicated by the Electrical Characteristics if operated under different conditions.

LC709301F

SIO1 SERIAL I/O CHARACTERISTICS (Note 10)

Parameter		Symbol	Pin/Remarks	Conditions	V _{DD} [V]	Specification				
						Min	Typ	Max	Unit	
Serial clock	Input clock	Frequency	tSCK(1)	SCK1 (P12)	• See Fig. 6.	1.8 to 5.5	2	-	-	tCYC
		Low level pulse width	tSCKL(1)				1	-	-	
		High level pulse width	tSCKH(1)				1	-	-	
	Output clock	Frequency	tSCK(2)	SCK1 (P12)	• CMOS output type selected • See Fig. 6.	1.8 to 5.5	2	-	-	tSCK
		Low level pulse width	tSCKL(2)				1/2			
		High level pulse width	tSCKH(2)				1/2			
Serial input	Data setup time	tsDI(1)	SI1 (P11), SB1 (P11)	• Specified with respect to rising edge of SIOCLK. • See Fig. 6.	1.8 to 5.5	0.05	-	-	μs	
	Data hold time	thDI(1)				0.05	-	-		
Serial output	Output delay time	tdDO(1)	SO1 (P10), SB1 (P11)	• Specified with respect to falling edge of SIOCLK • Specified as the time up to the beginning of output change in open drain output mode. • See Fig. 6.	1.8 to 5.5	-	-	(1/3)tCYC +0.08		

10. These specifications are theoretical values. Margins must be allowed according to the actual operating conditions.

PULSE INPUT CONDITIONS (Ta = -40°C to +85°C, V_{SS1} = V_{SS2} = 0 V)

Parameter	Symbol	Pin/Remarks	Conditions	V _{DD} [V]	Specification			
					Min	Typ	Max	Unit
High/low level pulse width	tPIH(1) tPIL(1)	INT0 (P70), INT1 (P17), INT2 (P16), INT4 (P13, P14)	• Interrupt source flag can be set. • Event inputs for timer 0 or 1 are enabled.	1.8 to 5.5	1	-	-	tCYC
	tPIH(2) tPIL(2)	INT3 (P15) when noise filter time constant is 1/1	• Interrupt source flag can be set. • Event inputs for timer 0 are enabled.	1.8 to 5.5	2	-	-	
	tPIH(3) tPIL(3)	INT3 (P15) when noise filter time constant is 1/32	• Interrupt source flag can be set. • Event inputs for timer 0 are enabled.	1.8 to 5.5	64	-	-	
	tPIH(4) tPIL(4)	INT3 (P15) when noise filter time constant is 1/128	• Interrupt source flag can be set. • Event inputs for timer 0 are enabled.	1.8 to 5.5	256	-	-	
	tPIL(5)	RES	• Resetting is enabled.	1.8 to 5.5	200	-	-	μs

LC709301F

AD CONVERTER CHARACTERISTICS ($V_{SS1} = V_{SS2} = 0\text{ V}$)

Parameter	Symbol	Pin/Remarks	Conditions	Specification			
				V_{DD} [V]	Min	Typ	Max

12 BITS AD CONVERTER MODE ($T_a = -40^\circ\text{C}$ to $+85^\circ\text{C}$)

Resolution	N	AN2 (P02) AN3 (P03) AN4 (P04)		1.8 to 5.5	-	12	-	bit
Absolute accuracy	ET		(Note 11)	1.8 to 5.5	-	-	± 16	LSB
Conversion time	TCAD	AN5 (P15) AN6 (P14) AN7 (P13) AN9 (P70) AN14 (P24)	• See conversion time calculation method. (Note 12)	2.7 to 5.5	32	-	115	μs
				2.2 to 5.5	134	-	215	
				1.8 to 5.5	400	-	430	
Analog input voltage range	VAIN(1)	(Note 13)	When V_{DD} is selected	1.8 to 5.5	V_{SS}	-	V_{DD}	V
	VAIN(2)		When internal VREF = 4 V is selected. $V_{REF} \leq V_{DD}$	4.3 to 5.5	V_{SS}	-	VREF	
			When internal VREF = 2 V is selected. $V_{REF} \leq V_{DD}$	2.3 to 3.6	V_{SS}	-	VREF	
Analog port input current	IAINH		$V_{AIN} = V_{DD}$	1.8 to 5.5	-	-	1	μA
	IAINL		$V_{AIN} = V_{SS}$	1.8 to 5.5	-1	-	-	

8 BITS AD CONVERTER MODE ($T_a = -40^\circ\text{C}$ to $+85^\circ\text{C}$)

Resolution	N	AN2 (P02) AN3 (P03) AN4 (P04)		1.8 to 5.5	-	8	-	bit
Absolute accuracy	ET		(Note 11)	1.8 to 5.5	-	-	± 1.5	LSB
Conversion time	TCAD	AN5 (P15) AN6 (P14) AN7 (P13) AN9 (P70) AN14 (P24)	• See conversion time calculation method. (Note 12)	2.7 to 5.5	20	-	90	μs
				2.2 to 5.5	80	-	135	
				1.8 to 5.5	245	-	265	
Analog input voltage range	VAIN(1)	(Note 13)	When V_{DD} is selected	1.8 to 5.5	V_{SS}	-	V_{DD}	V
	VAIN(2)		When internal VREF = 4 V is selected. $V_{REF} \leq V_{DD}$	4.3 to 5.5	V_{SS}	-	VREF	
			When internal VREF = 2 V is selected. $V_{REF} \leq V_{DD}$	2.3 to 3.6	V_{SS}	-	VREF	
Analog port input current	IAINH		$V_{AIN} = V_{DD}$	1.8 to 5.5	-	-	1	μA
	IAINL		$V_{AIN} = V_{SS}$	1.8 to 5.5	-1	-	-	

11. The quantization error ($\pm 1/2\text{LSB}$) is excluded from the absolute accuracy. The absolute accuracy is measured when no change occurs in the I/O state of the pins that are adjacent to the analog input channel during AD conversion processing.

12. The conversion time refers to the interval from the time a conversion starting instruction is issued till the time the complete digital value against the analog input value is loaded in the result register.

The conversion time is twice the normal value when one of the following conditions occurs:

- The first AD conversion executed in the 12-bit AD conversion mode after a system reset
- The first AD conversion executed after the AD conversion mode is switched from 8-bit to 12-bit AD conversion mode

13. See page 16, "[10x/20x amplifier characteristics](#)", for analog channel 0 (10x/20z amplifier output).

Conversion Time Calculation Method

12bits AD Converter Mode: TCAD (Conversion time) = $((52 / (\text{AD division ratio})) + 2) \times (1 / 3) \times \text{tCYC}$

8bits AD Converter Mode: TCAD (Conversion time) = $((32 / (\text{AD division ratio})) + 2) \times (1 / 3) \times \text{tCYC}$

LC709301F

RECOMMENDED OPERATING CONDITIONS

External Oscillation (FmCF)	Operating Supply Voltage Range (V _{DD})	System Division Ratio (SYSDIV)	Cycle Time (tCYC)	AD Division Ratio (ADDIV)	AD Conversion Time (TCAD)	
					12bit AD	8bit AD
CF-8 MHz	2.7 V to 5.5 V	1/1	375 ns	1/8	52.25 μs	32.25 μs
	2.2 V to 5.5 V	1/1	375 ns	1/32	208.25 μs	128.25 μs
CF-4 MHz	2.7 V to 5.5 V	1/1	750 ns	1/8	104.5 μs	64.5 μs
	2.2 V to 5.5 V	1/1	750 ns	1/16	208.5 μs	128.5 μs
	1.8 V to 5.5 V	1/1	750 ns	1/32	416.5 μs	256.5 μs

Functional operation above the stresses listed in the Recommended Operating Ranges is not implied. Extended exposure to stresses beyond the Recommended Operating Ranges limits may affect device reliability.

REFERENCE VOLTAGE GENERATOR CIRCUIT (VREF) CHARACTERISTICS (T_a = -40°C to +85°C, V_{SS1} = V_{SS2} = 0 V)

Parameter	Symbol	Pin/Remarks	Conditions	V _{DD} [V]	Specification			Unit
					Min	Typ	Max	
VREF = 2 V voltage accuracy	VREF2VO	VREF (Note 15)		1.8 to 2.0	V _{DD} -0.1	-	V _{DD}	V
				2.0 to 5.5	1.90	-	2.02	
				2.3 to 5.5	1.98	-	2.02	
VREF = 4 V voltage accuracy	VREF4VO			1.8 to 4.0	V _{DD} -0.1	-	V _{DD}	
				4.0 to 5.5	3.90	-	4.04	
				4.3 to 5.5	3.96	-	4.04	
VREF output current	VREFIO			1.8 to 5.5	V _{SS}	-	0.5	mA
Operation stabilization time (Note 14)	tVREFW			1.8 to 5.5	-	-	5	ms

14. Refers to the interval between the time VR12ON and VR24ON are set to 1 and the time operation gets stabilized.

15. An external 4.7 μF capacitor must be connected to the VREF pin to stabilize the VREF voltage.

LC709301F

10x/20x AMPLIFIER CHARACTERISTICS (Ta = -40°C to +85°C, V_{SS1} = V_{SS2} = 0 V)

Parameter	Symbol	Pin/Remarks	Conditions	V _{DD} [V]	Specification			
					Min	Typ	Max	Unit
20x Amplifier gain	APGAIN20 See Fig. 8	P00/APIP P01/APIP	1) APDIR = 0 & GAIN20 = 1. • P00 = 0 V, P01 ≥ 0 V 2) APDIR = 1 & GAIN20 = 1. • P01 = 0 V, P00 ≥ 0 V	4.3 to 5.0	-	20.5	-	
			1) APDIR = 0 & GAIN20 = 1. • P01 = 0 V, P00 ≤ 0 V 2) APDIR = 1 & GAIN20 = 1. • P00 = 0 V, P01 ≤ 0 V		-	-19.9	-	
20x Amplifier offset	VAPIO20		1) APDIR = 0 & GAIN20 = 1. • P01 = 0 V, P00 ≤ 0 V or P00 = 0 V, P01 ≥ 0 V 2) APDIR = 1 & GAIN20 = 1. • P01 = 0 V, P00 ≥ 0 V or P00 = 0 V, P01 ≤ 0 V		200	-	600	mV
20x Amplifier input voltage range	VAPIM20-1	P00/APIP	1)	P01/APIP = 0 V	-0.17	-	0	V
	VAPIP20-1	P01/APIP		P00/APIP = 0 V	0	-	0.17	
	VAPIM20-2	P00/APIP	2)	P01/APIP = 0 V	0	-	0.17	V
	VAPIP20-2	P01/APIP		P00/APIP = 0 V	-0.17	-	0	
10x Amplifier gain	APGAIN10 See Fig. 8	P00/APIP P01/APIP	3) APDIR = 0 & GAIN20 = 0. • P00 = 0 V, P01 ≥ 0 V 4) APDIR = 1 & GAIN20 = 0. • P01 = 0 V, P00 ≥ 0 V		-	10.8	-	
			3) APDIR = 0 & GAIN20 = 0. • P01 = 0 V, P00 ≤ 0 V 4) APDIR = 1 & GAIN20 = 0. • P00 = 0 V, P01 ≤ 0 V	-	-9.95	-		
10x Amplifier offset	VAPIO10		3) APDIR = 0 & GAIN20 = 0. • P01 = 0 V, P00 ≤ 0 V or P00 = 0 V, P01 ≥ 0 V 4) APDIR = 1 & GAIN20 = 0. • P01 = 0 V, P00 ≥ 0 V or P00 = 0 V, P01 ≤ 0 V		100	-	300	mV
10x Amplifier input voltage range	VAPIM10-3	P00/APIP	3)	P01/APIP = 0 V	-0.24	-	0	V
	VAPIP10-3	P01/APIP		P00/APIP = 0 V	0	-	0.24	
	VAPIM10-4	P00/APIP	4)	P01/APIP = 0 V	0	-	0.24	V
	VAPIP10-4	P01/APIP		P00/APIP = 0 V	-0.24	-	0	
Amplifier input port input current	IAPINL	P00/APIP	P00/APIP = V _{SS} - 0.2 V		-1	-	-	μA
	IAPINH	P01/APIP	P01/APIP = V _{DD}		-	-	1	
Operation stabilization time (Note 16)	tAPW				-	-	20	μs

16. Refers to the interval between the time APON is set to 1 and the time operation gets stabilized.

Amplifier Input Voltage Calculation Method: See Fig. 8

$VAPFUL = (VREFAD - VAPIO) / APGAIN$ (VREFAD can be selected from internal - VREF4V, internal - VREF2V and V_{DD}.)

Note: VAPFUL must not exceed VAPIP or VAPIM.

LC709301F

COMPARATOR CHARACTERISTICS (Ta = -40°C to +85°C, VSS1 = VSS2 = 0 V)

Parameter	Symbol	Pin/Remarks	Conditions	Specification				
				VDD [V]	Min	Typ	Max	Unit
Comparator threshold voltage (Note 17)	VCMVT	P02/CPIM		2.5 to 5.5	1.12	1.22	1.32	V
Input voltage range	VCMIN			2.5 to 5.5	VSS	-	VDD	V
Offset voltage	VOFF		• Within input voltage range	2.5 to 5.5	-	±10	±30	mV
Response time	tRT		• Within input voltage range • Input amplitude = 100 mV • Overdrive = 50 mV	2.5 to 5.5	-	200	600	ns
Operation stabilization time (Note 18)	tCMW			2.5 to 5.5	-	-	1.0	µs

17. Comparator output=High level when (P02/CPIM voltage) < VCMVT

Comparator output=Low level when (P02/CPIM voltage) > (VCMVT + VOFF)

18. Refers to the interval between the time CPON is set to 1 and the time operation gets stabilized.

TEMPERATURE SENSOR CHARACTERISTICS (Ta = -40°C to +85°C, VSS1 = VSS2 = 0 V)

Parameter	Symbol	Pin/Remarks	Conditions	Specification				
				VDD [V]	Min	Typ	Max	Unit
4-DIODE MODE								
Output voltage	VOTMP4(1)		Ta = -40°C	5.0	3.23	3.25	3.27	V
	VOTMP4(2)		Ta = +25°C	5.0	2.75	2.77	2.80	
	VOTMP4(3)		Ta = +85°C	5.0	2.28	2.31	2.34	
Sensitivity	Vsen4		Ta = -40 to +85°C	3.5 to 5.5	-7.63	-7.54	-7.45	mV/°C
Absolute accuracy (Note 19, 20)	ETTMP4	Vref = 4 [V]	Ta = (60 ±10) °C (Note 21)	3.5 to 5.5	-	±2.5	±5	°C
			Ta = -40 to +85°C	3.5 to 5.5	-	±5	±10	

2-DIODE MODE

Output voltage	VOTMP2(1)		Ta = -40°C	3.3	1.61	1.63	1.64	V
	VOTMP2(2)		Ta = +25°C	3.3	1.37	1.39	1.40	
	VOTMP2(3)		Ta = +85°C	3.3	1.14	1.16	1.17	
Sensitivity	Vsen2		Ta = -40 to +85°C	2.0 to 5.5	-3.81	-3.77	-3.72	mV/°C
Absolute accuracy (Note 19, 20)	ETTMP2	Vref = 2 [V]	Ta = (60 ±10) °C (Note 22)	2.0 to 5.5	-	±2.5	±5	°C
			Ta = -40 to +85°C	2.0 to 5.5	-	±5	±10	

19. There are cases when the absolute accuracy specification value is exceeded when a large current flows through the ports.

20. Including error of AD Converter.

21. When using the Temperature sensor 60°C 2-diodes reference register D2TL / D2TH.

22. When using the Temperature sensor 60°C 4-diodes reference register D4TL / D4TH.

POWER-ON RESET (POR) CHARACTERISTICS (Ta = -40°C to +85°C, VSS1 = VSS2 = 0 V)

Parameter	Symbol	Pin/Remarks	Conditions	Specification				
				Option Selected Voltage	Min	Typ	Max	Unit
POR release voltage	PORRL		Option selected (Note 23)	1.67 V	1.10	-	1.79	V
Detection voltage unpredictable area	POUKS		See Fig. 9. (Note 24)	-	-	0.7	0.95	
Power supply rise time	PORIS		Power startup time from VDD = 0 V to 1.6 V	-	-	-	100	ms

23. The POR release voltage can be selected when the low-voltage detection feature is deselected.

24. There is an unpredictable area before the transistor starts to turn on.

LC709301F

LOW VOLTAGE RESET (LVD) CHARACTERISTICS (Ta = -40°C to +85°C, V_{SS1} = V_{SS2} = 0 V)

Parameter	Symbol	Pin/Remarks	Conditions	Option Selected Voltage	Specification			
					Min	Typ	Max	Unit
LVD reset voltage (Note 26)	LVDET		Option selected See Fig. 10. (Note 25, 27)	1.91 V	1.81	1.91	2.01	V
				2.01 V	1.91	2.01	2.11	
				2.31 V	2.21	2.31	2.41	
				2.51 V	2.41	2.51	2.61	
				2.81 V	2.71	2.81	2.93	
				3.79 V	3.69	3.79	3.92	
				4.28 V	4.18	4.28	4.41	
LVD voltage hysteresis	LVHYS			1.91 V	-	55	-	mV
				2.01 V	-	55	-	
				2.31 V	-	55	-	
				2.51 V	-	55	-	
				2.81 V	-	60	-	
				3.79 V	-	65	-	
				4.28 V	-	65	-	
Detection voltage unpredictable area	LVUKS		See Fig. 10. (Note 28)	-	-	0.7	0.95	V
Minimum low voltage detection width (response sensitivity)	TLVDW		LVDET-0.5 V See Fig. 11.	-	0.2	-	-	ms

25. The LVD reset voltage can be selected from 7 levels when the low-voltage detection feature is selected.

26. The hysteresis voltage is not included in the LVD reset voltage specification value.

27. There are cases when the LVD reset voltage specification value is exceeded when a greater change in the output level or large current is applied to the port.

28. There is an unpredictable area before the transistor starts to turn on.

CONSUMPTION CURRENT CHARACTERISTICS (Ta = -40°C to +85°C, V_{SS1} = V_{SS2} = 0 V)

Parameter	Symbol	Pin/Remarks	Conditions	V _{DD} [V]	Specification			
					Min	Typ	Max	Unit
Normal mode consumption current (Note 29, 30)	IDDOP(1)	V _{DD1}	<ul style="list-style-type: none"> External clock = 8 MHz System clock set to 8 MHz mode Internal low-/medium-speed RC oscillation stopped Internal high-speed RC oscillation stopped Frequency division ratio set to 1/1 	2.2 to 5.5	-	3.8	5.2	mA
				2.2 to 3.6	-	2.2	2.9	
	IDDOP(2)		<ul style="list-style-type: none"> External clock = 4 MHz System clock set to 4 MHz mode Internal low-/medium-speed RC oscillation stopped Internal high-speed RC oscillation stopped Frequency division ratio set to 1/1 	1.8 to 5.5	-	2.1	3.5	
				1.8 to 3.6	-	1.1	1.7	
	IDDOP(3)		<ul style="list-style-type: none"> Internal low-speed RC oscillation stopped System clock set to internal medium-speed RC oscillation mode Internal high-speed RC oscillation stopped Frequency division ratio set to 1/2 	1.8 to 5.5	-	0.23	0.39	
				1.8 to 3.6	-	0.13	0.19	
	IDDOP(4)		<ul style="list-style-type: none"> Internal low-/medium-speed RC oscillation stopped System clock set to internal high-speed RC oscillation mode Frequency division ratio set to 1/1 	1.8 to 5.5	-	2.7	3.6	
				1.8 to 3.6	-	1.7	2.3	
	IDDOP(5)		<ul style="list-style-type: none"> System clock set to internal low-speed RC oscillation mode Internal medium-speed RC oscillation stopped Internal high-speed RC oscillation stopped Frequency division ratio set to 1/1 	1.8 to 5.5	-	10	42	μA
				1.8 to 3.6	-	6	21	

LC709301F

CONSUMPTION CURRENT CHARACTERISTICS (Ta = -40°C to +85°C, VSS1 = VSS2 = 0 V) (continued)

Parameter	Symbol	Pin/Remarks	Conditions	VDD [V]	Specification			
					Min	Typ	Max	Unit
HALT mode consumption current (Note 29, 30)	IDDHALT(1)	VDD1	HALT mode • External clock=8Mhz • System clock set to 8MHz mode • Internal low-/medium-speed RC oscillation stopped • Internal high-speed RC oscillation stopped • Frequency division ratio set to 1/1	2.2 to 5.5	-	2.0	3.2	mA
				2.2 to 3.6	-	1.0	1.6	
	IDDHALT(2)		HALT mode • External clock = 4 MHz • System clock set to 4 MHz mode • Internal low-/medium-speed RC oscillation stopped • Internal high-speed RC oscillation stopped • Frequency division ratio set to 1/1	1.8 to 5.5	-	1.2	2.4	
				1.8 to 3.6	-	0.5	1.0	
	IDDHALT(3)		HALT mode • Internal low-speed RC oscillation stopped • System clock set to internal medium-speed RC oscillation mode • Internal high-speed RC oscillation stopped • Frequency division ratio set to 1/2	1.8 to 5.5	-	0.12	0.25	
				1.8 to 3.6	-	0.06	0.11	
	IDDHALT(4)		HALT mode • Internal low-/medium-speed RC oscillation stopped • System clock set to internal high-speed RC oscillation mode • Frequency division ratio set to 1/1	1.8 to 5.5	-	1.1	1.7	
				1.8 to 3.6	-	0.7	1.0	
	IDDHALT(5)		HALT mode • System clock set to internal low-speed RC oscillation mode • Internal medium-speed RC oscillation stopped • Internal high-speed RC oscillation stopped • Frequency division ratio set to 1/1	1.8 to 5.5	-	3.8	37	
				1.8 to 3.6	-	2.4	17	
HOLD mode consumption current (Note 29, 30)	IDDHOLD(1)	VDD1	HOLD mode	1.8 to 5.5	-	0.023	33.2	μA
				1.8 to 3.6	-	0.012	14.2	
	IDDHOLD(2)		HOLD mode • LVD option selected	1.8 to 5.5	-	1.09	26.9	
				1.8 to 3.6	-	0.86	11.8	
Timer HOLD mode consumption current (Note 29, 30)	IDDHOLD(3)	Timer HOLD mode • FmSRC = 30 kHz internal low-speed RC oscillation mode	1.8 to 5.5	-	0.63	34		
			1.8 to 3.6	-	0.53	15		

29. The consumption current value includes none of the currents that flow into the output transistors and internal pull-up resistors.

30. Unless otherwise specified, the consumption current for the LVD circuit is not included.

F-ROM PROGRAMMING CHARACTERISTICS (Ta = 10°C to +55°C, VSS1 = VSS2 = 0 V)

Parameter	Symbol	Pin/Remarks	Conditions	VDD [V]	Specification			
					Min	Typ	Max	Unit
Onboard programming current	IDDFW(1)	VDD1	• Excluding power dissipation in the microcontroller block	2.2 to 5.5	-	5	10	mA
Programming time	tFW(1)		• Erasing time	2.2 to 5.5	-	20	30	ms
	tFW(2)		• Programming time					

LC709301F

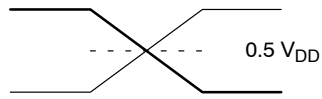
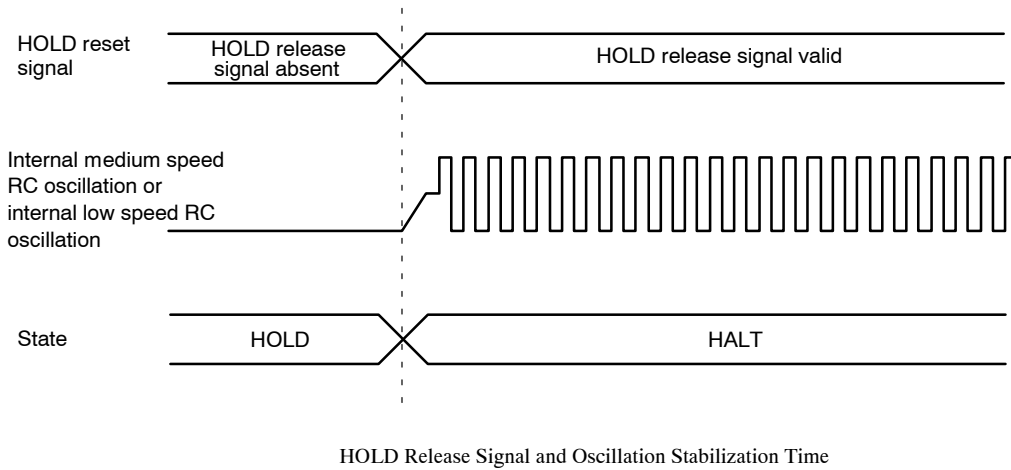
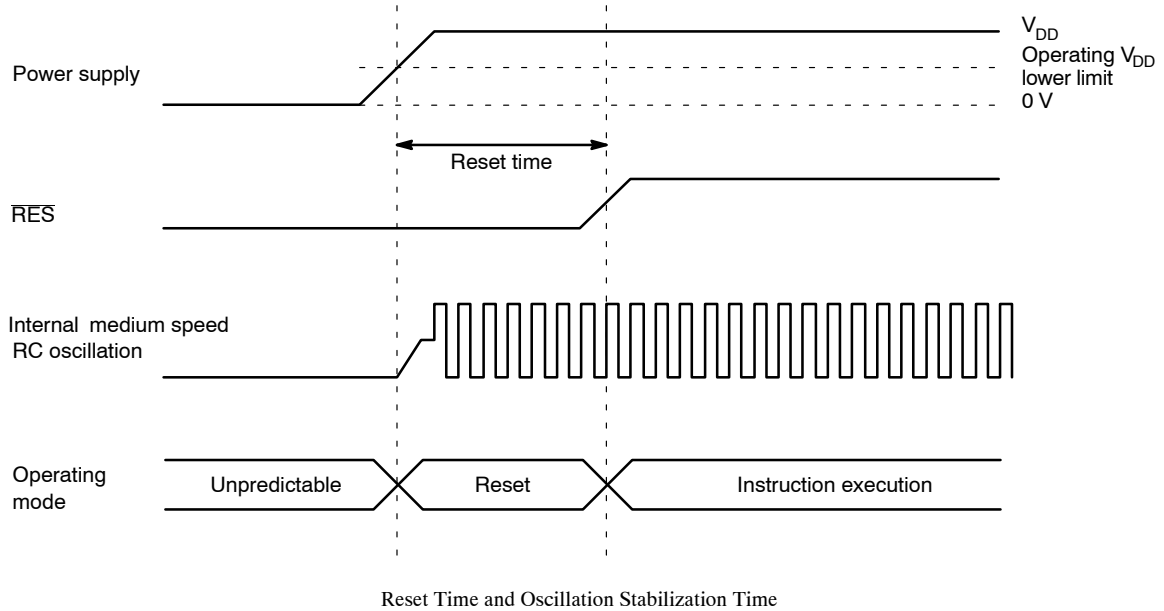

Figure 3. AC Timing Measurement Point



NOTE: When an external oscillation circuit is selected.

Figure 4. Oscillation Stabilization Time

LC709301F

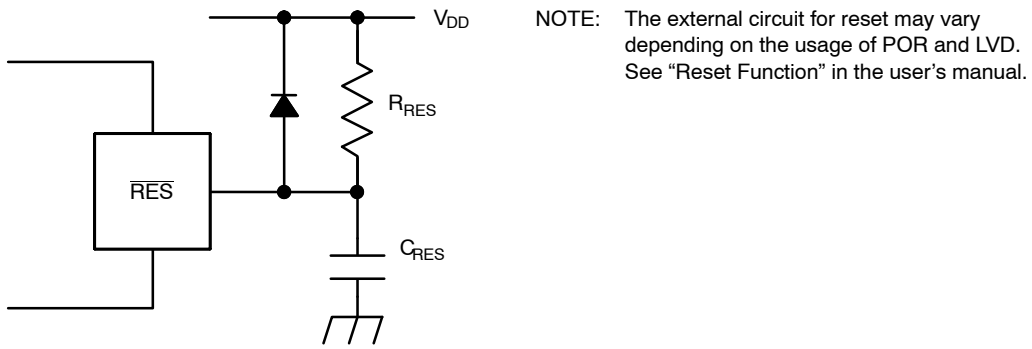

Figure 5. Sample Reset Circuit

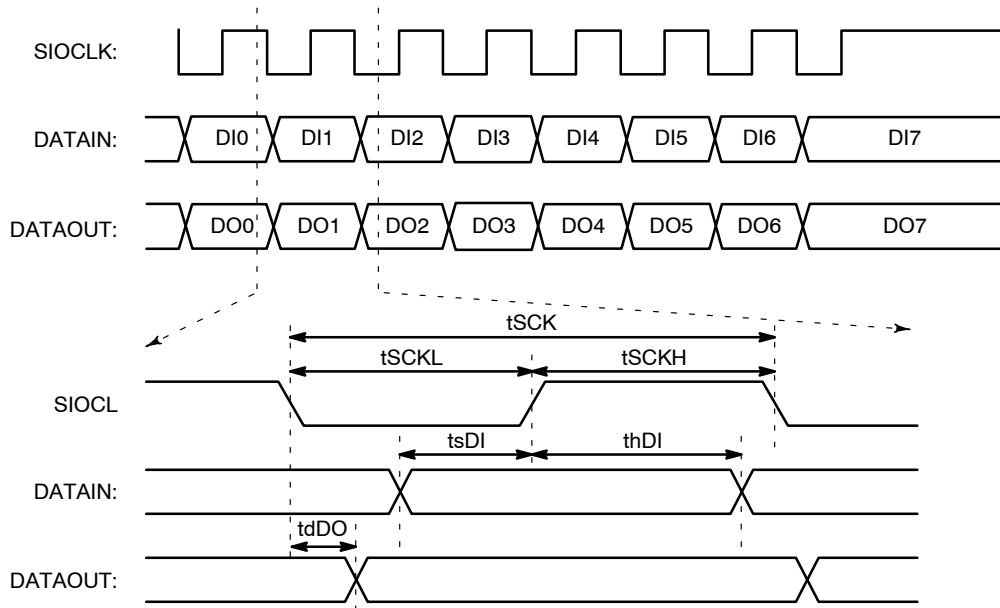

Figure 6. Serial I/O Waveform

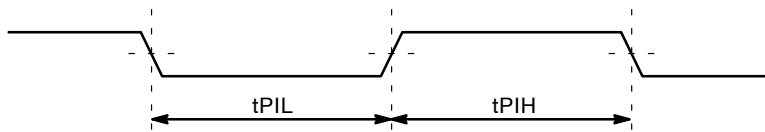

Figure 7. Pulse Input Timing Signal Waveform

LC709301F

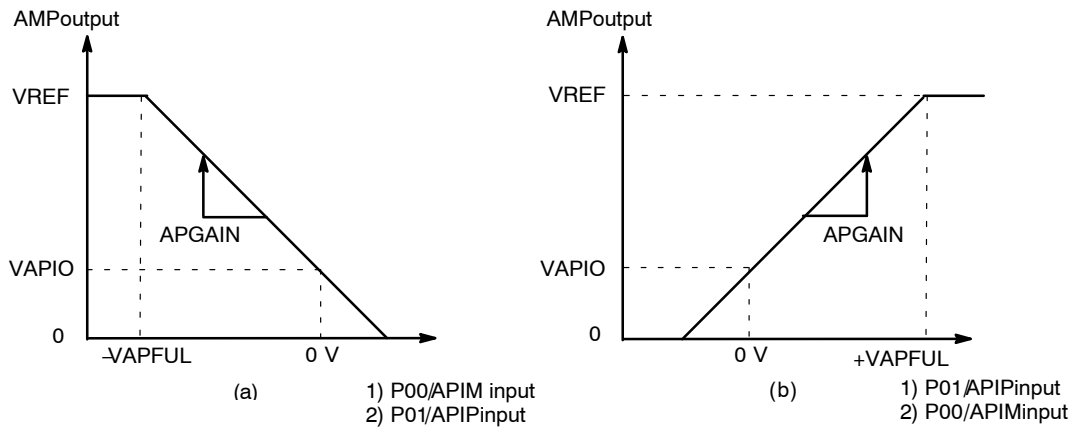

Figure 8. 10x / 20x Amplifier Characteristics

- a) 1) When P01/APIP is 0 V, P00/APIP \leq 0 V.
2) When P00/APIP is 0 V, P01/APIP \leq 0 V.

- b) 1) When P00/APIP is 0 V, P01/APIP \geq 0 V.
2) When P01/APIP is 0 V, P00/APIP \geq 0 V.

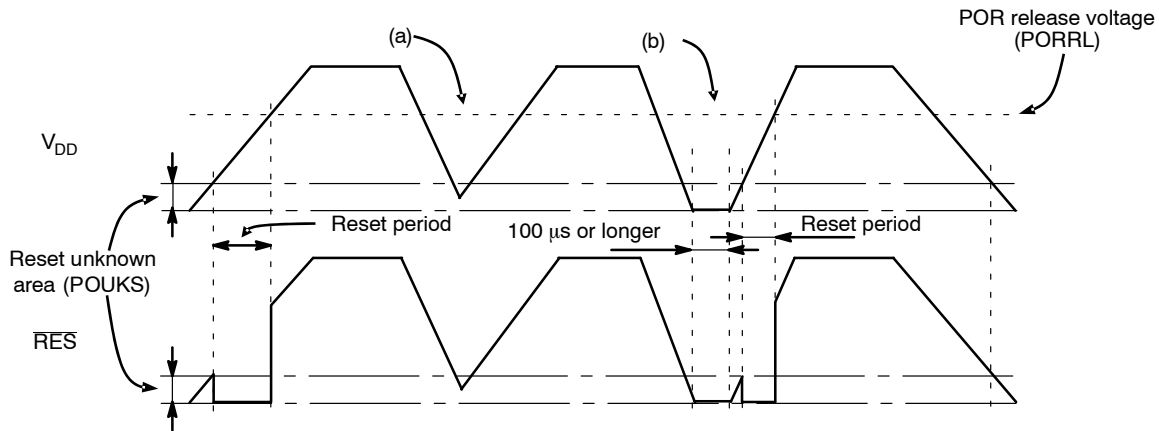

Figure 9. Example of POR Only (LVD Deselected) Mode Waveforms (at Reset Pin with R_{RES} Pull-up Resistor Only)

- The POR function generates a reset only when the power voltage goes up from the V_{SS} level.
- No stable reset will be generated if power is turned on again when the power level does not go down to the V_{SS} level as shown in (a). If such a case is anticipated, use the LVD function together with the POR function or implement an external reset circuit as shown below.
- A reset is generated only when the power level goes down to the V_{SS} level as shown in (b) and power is turned on again after this condition continues for 100 μ s or longer.

LC709301F

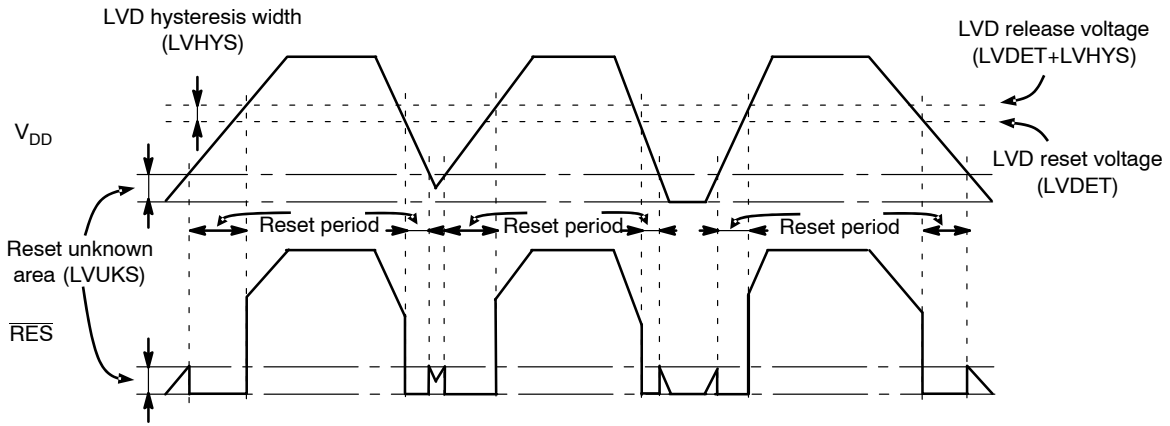

Figure 10. Example of POR + LVD Mode Waveforms (at Reset Pin with R_{RES} Pull-up Resistor Only)

- Resets are generated both when power is turned on and when the power level lowers.
- A hysteresis width (LVHYS) is provided to prevent the repetitions of reset release and entry cycles near the detection level.

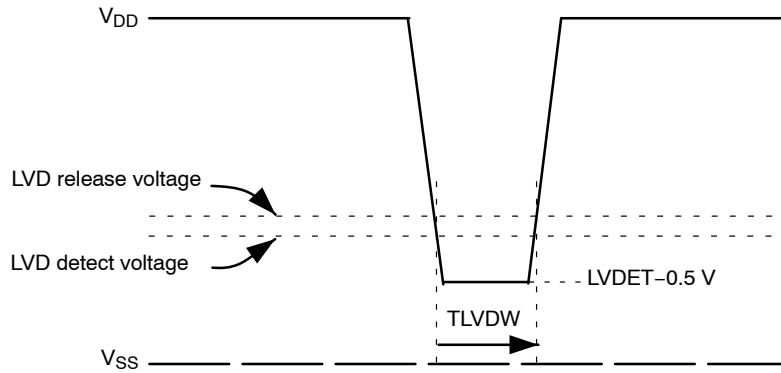

Figure 11. Minimum Low Voltage Detection Width (Example of Voltage Sag/Fluctuation Waveform)

ORDERING INFORMATION

Device Order Number	Package Type	Shipping [†]
LC709301FRF-AUNH	VCT24 3.5x3.5, 0.5P (Pb-Free / Halogen Free)	2000 / Tape & Reel

[†]For information on tape and reel specifications, including part orientation and tape sizes, please refer to our Tape and Reel Packaging Specifications Brochure, BRD8011/D.

LC709301F

PACKAGE DIMENSIONS

VCT24 3.5x3.5, 0.5P
CASE 601AD
ISSUE A

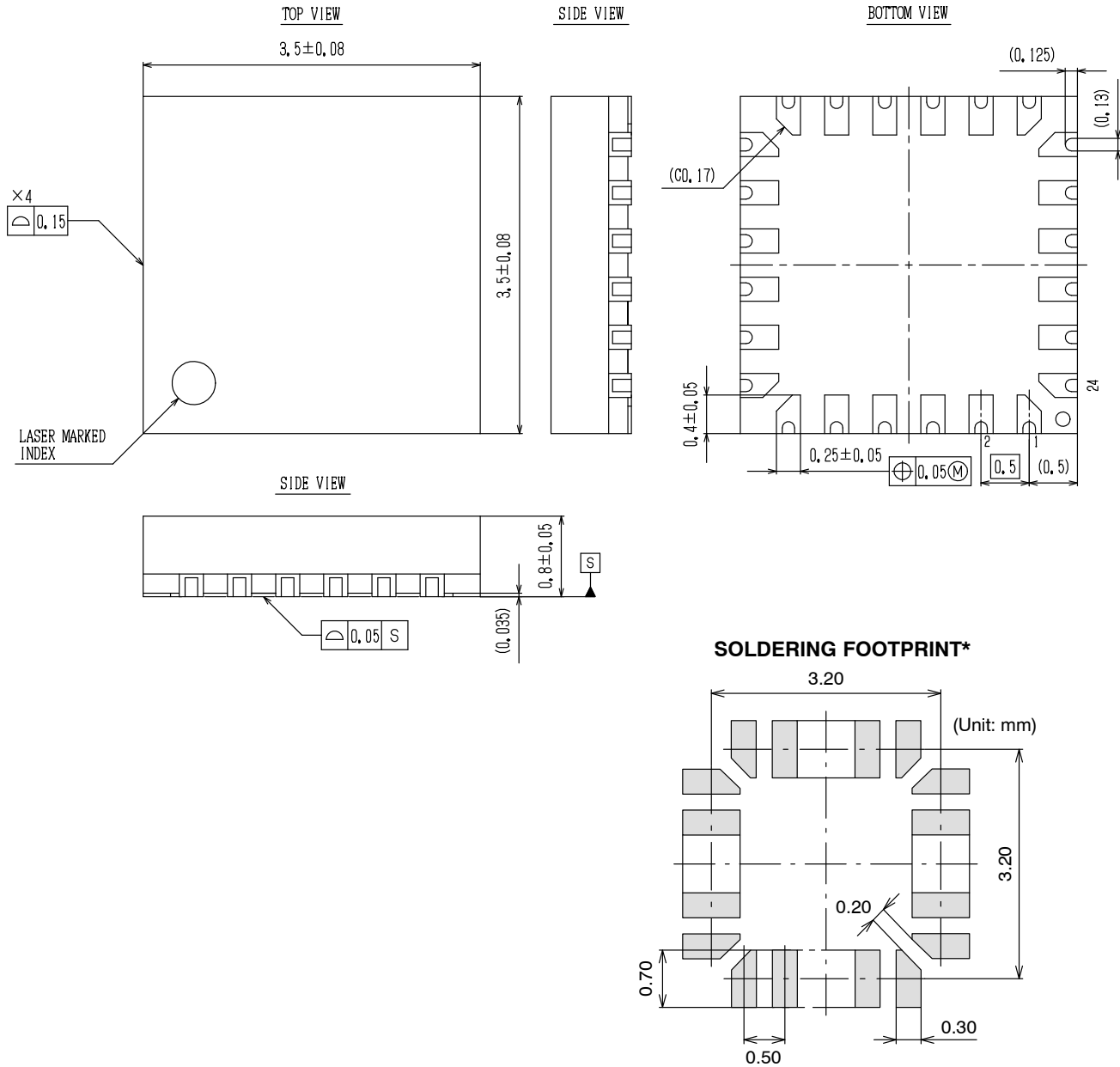

NOTE: The measurements are not to guarantee but for reference only.

*For additional information on our Pb-Free strategy and soldering details, please download the ON Semiconductor Soldering and Mounting Techniques Reference Manual, SOLDERRM/D.

ON Semiconductor and  are trademarks of Semiconductor Components Industries, LLC dba ON Semiconductor or its subsidiaries in the United States and/or other countries. ON Semiconductor owns the rights to a number of patents, trademarks, copyrights, trade secrets, and other intellectual property. A listing of ON Semiconductor's product/patent coverage may be accessed at www.onsemi.com/site/pdf/Patent-Marking.pdf. ON Semiconductor reserves the right to make changes without further notice to any products herein. ON Semiconductor makes no warranty, representation or guarantee regarding the suitability of its products for any particular purpose, nor does ON Semiconductor assume any liability arising out of the application or use of any product or circuit, and specifically disclaims any and all liability, including without limitation special, consequential or incidental damages. Buyer is responsible for its products and applications using ON Semiconductor products, including compliance with all laws, regulations and safety requirements or standards, regardless of any support or applications information provided by ON Semiconductor. "Typical" parameters which may be provided in ON Semiconductor data sheets and/or specifications can and do vary in different applications and actual performance may vary over time. All operating parameters, including "Typicals" must be validated for each customer application by customer's technical experts. ON Semiconductor does not convey any license under its patent rights nor the rights of others. ON Semiconductor products are not designed, intended, or authorized for use as a critical component in life support systems or any FDA Class 3 medical devices or medical devices with a same or similar classification in a foreign jurisdiction or any devices intended for implantation in the human body. Should Buyer purchase or use ON Semiconductor products for any such unintended or unauthorized application, Buyer shall indemnify and hold ON Semiconductor and its officers, employees, subsidiaries, affiliates, and distributors harmless against all claims, costs, damages, and expenses, and reasonable attorney fees arising out of, directly or indirectly, any claim of personal injury or death associated with such unintended or unauthorized use, even if such claim alleges that ON Semiconductor was negligent regarding the design or manufacture of the part. ON Semiconductor is an Equal Opportunity/Affirmative Action Employer. This literature is subject to all applicable copyright laws and is not for resale in any manner.

PUBLICATION ORDERING INFORMATION

LITERATURE FULFILLMENT:

Literature Distribution Center for ON Semiconductor
19521 E. 32nd Pkwy, Aurora, Colorado 80011 USA
Phone: 303-675-2175 or 800-344-3860 Toll Free USA/Canada
Fax: 303-675-2176 or 800-344-3867 Toll Free USA/Canada
Email: orderlit@onsemi.com

N. American Technical Support: 800-282-9855 Toll Free
USA/Canada
Europe, Middle East and Africa Technical Support:
Phone: 421 33 790 2910

ON Semiconductor Website: www.onsemi.com

Order Literature: <http://www.onsemi.com/orderlit>

For additional information, please contact your local
Sales Representative