



## LC868116/12/08A

### 8-Bit Single Chip Microcontroller with 16/12/08K-Byte ROM and 640-Byte RAM On Chip

#### Preliminary

#### Overview

The LC868116A/12A/08A microcontrollers are 8-bit single chip microcontrollers with the following on-chip functional blocks :

- CPU : Operable at a minimum bus cycle time of 0.5 $\mu$ s (microseconds)
- On-chip ROM maximum capacity : 16K bytes
- On-chip RAM capacity : 640 bytes
- Dot-matrix liquid crystal display (LCD) automatic display controller / driver
- External memory
- 16-bit timer / counter (or two 8-bit timers)
- 16-bit timer / PWM (or two 8-bit timers)
- Two 8-bit synchronous serial-interface circuits
- 13-source 9-level vectored interrupt system

All of the above functions are fabricated on a single chip

- Any and all SANYO products described or contained herein do not have specifications that can handle applications that require extremely high levels of reliability, such as life-support systems, aircraft's control systems, or other applications whose failure can be reasonably expected to result in serious physical and/or material damage. Consult with your SANYO representative nearest you before using any SANYO products described or contained herein in such applications.
- SANYO assumes no responsibility for equipment failures that result from using products at values that exceed, even momentarily, rated values (such as maximum ratings, operating condition ranges, or other parameters) listed in products specifications of any and all SANYO products described or contained herein.



## - Ports

Port 2 : Address output of upper 8-bit

Uses  $\overline{\text{EROE}}$  terminal ( $\overline{\text{OE}}$  signal of the external ROM)

## 1. Using the external latch

Port 0 : Address output of lower 8-bit, data input port

Uses the ADLC terminal (latch clock of the lower 8-bit address signal)

## 2. Not use the external latch

Port 0 : Input port of data

Port 3 : Address output of lower 8-bit

## - External data memory access function

Using the LDC instruction

External memory capacity : 16M bytes

## 1. Internal program memory

Switch the reference of internal ROM data/external ROM data by program.

## 2. External program memory

Reference external ROM data only.

## Ports

Port 2 : Address output of upper 8-bit

Port 5 : Bank address output

Uses  $\overline{\text{EROE}}$  terminal ( $\overline{\text{OE}}$  signal of the external ROM)

## 1. Using external latch

Port 0 : Address output of lower 8-bit, input port of data

Uses the ADLC terminal (latch clock of the lower 8-bit address signal)

## 2. Not use external latch

Port 0 : Input port of data

Port 3 : Address output of lower 8-bit

## - External RAM memory access function

Using the LDX, STX instruction

External memory capacity : 16M bytes

## Ports

Port 2 : Address output of upper 8-bit

Port 5 : Bank address output

Uses the P46 terminal ( $\overline{\text{OE}}$  signal of external RAM) : the LDX instruction execution

Uses the P47 terminal ( $\overline{\text{WE}}$  signal of external RAM) : the STX instruction execution

## 1. Using the external latch circuit

Port 0 : Address output of lower 8-bit, input/output port of data

Uses the ADLC terminal (latch clock of the lower 8-bit address signal)

## 2. Not use the external latch circuit

Port 0 : Input/output port of data

Port 3 : Address output of lower 8-bit

## (6) LCD automatic display controller

- Display duty : 1/4 - 1/32 duty

\* Up to 1/32 display duty can be specified by program. VDD allows up to 6V. Select the preferable LCD panel within this range.

- Display bias : 1/4, 1/5, 1/7 bias

- Programmable character display / graphic display

- Character display

## 1. On-chip character generator ROM

ROM capacity : 8960 bits

Character font : 5 × 7 dots

Number of Characters : 256

2. LCD instruction

- Display : ON/OFF
- Cursor : ON/OFF/BLINK
- Character blink : ON/OFF
- Character scroll : Control by specified starting address

- Graphic display

- LC868100 series : 1024 dots Maximum
- External segment driver : Enable to extend of LCD drive

- LCD contrast

- LCD display contrast programmable

- LCD display power supply

- Doubler circuit available within  $VDD \leq 3V$ .
- \* Doubler generates up to 6V.

- LCD driver

Following two kinds of combination can be selected by mask option

No.	Segment output port	Common output port
1	48	16
2	32	32

\* Up to 32 commons can be specified by mask option. As maximum LCD display voltage is 6V, please select the preferable LCD panel and the display condition with this range.

\* In general, the LCD driver cannot be expanded.

(7) Serial-interface

- Two 8-bit serial-interface circuits
- LSB first / MSB first function available
- Internal 8-bit baud-rate generator in common with two serial-interface circuits

(8) Timers

- Timer0 (T0L, T0H)

- 16-bit timer / counter
- 2-bit prescaler + 8-bit programmable prescaler
- Mode 0 : Two 8-bit timers with programmable prescaler
- Mode 1 : 8-bit timer with a programmable prescaler + 8-bit counter
- Mode 2 : 16-bit timer with a programmable prescaler
- Mode 3 : 16-bit counter

- Timer1 (T1L, T1H)

- 16-bit timer / PWM
- Mode 0 : Two 8-bit timers
- Mode 1 : 8-bit timer + 8-bit PWM
- Mode 2 : 16-bit timer
- Mode 3 : Variable-bit PWM (9-16 bits)

- Base timer

- Every 500ms overflow system for a clock application (using 32.768kHz crystal oscillation for Base timer clock)
- The Base timer clock selectable ; 32.768kHz crystal oscillation, System clock, and programmable prescaler output of Timer 0

(9) Buzzer output

- The Buzzer sound frequency selectable ; 4KHz, 2KHz

(10) Remote control receiver circuit (using P73/INT3/T0IN terminal)

- Noise rejection available
- The interrupt polarity selectable

(11) Watchdog timer

- The watchdog timer is taken on RC outside. (using P70/INT0 terminal)
- Watchdog timer operation selectable : interrupt system, system reset

(12) Interrupts system

- 13-source 9-level vectored interrupts :

1. External interrupt INT0 (includes watchdog timer)
2. External interrupt INT1
3. External interrupt INT2, timer / counter T0L (timer 0 lower 8 bits)
4. External interrupt INT3, base timer
5. Timer / counter T0H (timer 0 upper 8-bit)
6. Timer T1L (timer 1 lower 8-bit), Timer T1H (timer 1 upper 8-bit)
7. Serial interface SIO0
8. Serial interface SIO1
9. Port 0 or Port 3

- Interrupt priority control available

Microcomputer allows 3 levels of interrupt; low level, high level and highest level of multiplex interrupt. It can specify a low level or a high level interrupt priority from INT2/T0L through port 0 or port 3 (the above interrupt number from three through nine). It can also specify a low level or the highest level interrupt priority to INT0 and INT1.

(13) Sub-routine stack levels

- 128 levels (Max.) : stack area included in RAM area

(14) Multiplication and division

- 16 bits  $\times$  8-bit (7 instruction cycle times)
- 16 bits / 8-bit (7 instruction cycle times)

(15) Three oscillation circuits

- On-chip RC oscillation circuit using for the system clock, for the LCD display and for the step-up circuit.
- On-chip CF oscillation circuit using for the system clock, for the LCD display and for the step-up circuit.
- On-chip crystal oscillation circuit using for the system clock, for time-base clock and for the LCD display.

(16) Standby function

- HALT mode function

The HALT mode is used to reduce the power dissipation. In this operation mode, the program execution is stopped. This operation mode can be released by the interrupt request signals or setting to low level for the reset terminal ( $\overline{\text{RES}}$ ).

- HOLD mode function

The HOLD mode is used to freeze all the oscillations ; RC (internal), CF and Crystal oscillations. This mode can be released by the following operations:

- Reset terminal ( $\overline{\text{RES}}$ ) set to low level.
- Set to assigned level to INT0/1 terminals.
- Set to assigned level to Port 0/3.

(17) Factory shipment

- Chip  
QIC160 package shipping available for sample evaluation.

(18) Development support tools

- Evaluation (EVA) chip : LC868099
- Emulator : EVA86000 + ECB868000 (Evaluation chip board)

# Pin Assignment

Chip size : 4.98mm × 6.26mm  
 Pad size : 106μm × 106μm  
 Bonding area size : 90μm × 90μm  
 Chip thickness : 480μm±20μm

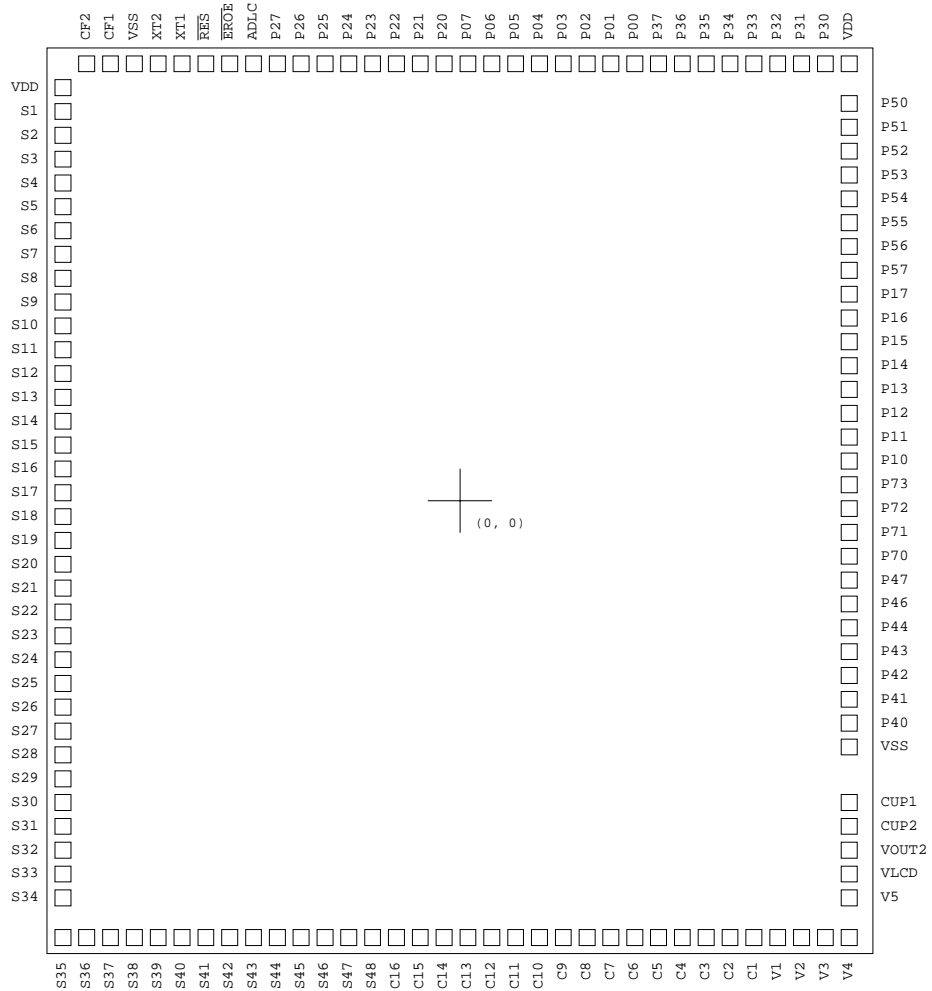

## Pad Name and coordinates table

Pad No.	Name	Coordinates		Pad No.	Name	Coordinates		Pad No.	Name	Coordinates	
		X $\mu$ m	Y $\mu$ m			X $\mu$ m	Y $\mu$ m			X $\mu$ m	Y $\mu$ m
1	VDD	-2240	2236	47	S46	-700	-2875	93	P16	2240	960
2	S1	-2240	2100	48	S47	-565	-2875	94	P17	2240	1096
3	S2	-2240	1965	49	S48	-429	-2875	95	P57	2240	1231
4	S3	-2240	1829	50	C16	-293	-2875	96	P56	2240	1367
5	S4	-2240	1694	51	C15	-158	-2875	97	P55	2240	1502
6	S5	-2240	1558	52	C14	-22	-2875	98	P54	2240	1638
7	S6	-2240	1422	53	C13	113	-2875	99	P53	2240	1774
8	S7	-2240	1287	54	C12	249	-2875	100	P52	2240	1909
9	S8	-2240	1151	55	C11	385	-2875	101	P51	2240	2045
10	S9	-2240	1016	56	C10	520	-2875	102	P50	2240	2180
11	S10	-2240	880	57	C9	656	-2875	103	VDD	2123	2875
12	S11	-2240	744	58	C8	791	-2875	104	P30	1987	2875
13	S12	-2240	609	59	C7	927	-2875	105	P31	1852	2875
14	S13	-2240	473	60	C6	1063	-2875	106	P32	1716	2875
15	S14	-2240	338	61	C5	1198	-2875	107	P33	1581	2875
16	S15	-2240	202	62	C4	1334	-2875	108	P34	1445	2875
17	S16	-2240	66	63	C3	1469	-2875	109	P35	1309	2875
18	S17	-2240	-69	64	C2	1605	-2875	110	P36	1174	2875
19	S18	-2240	-205	65	C1	1741	-2875	111	P37	1038	2875
20	S19	-2240	-340	66	V1	1876	-2875	112	P00	903	2875
21	S20	-2240	-476	67	V2	2012	-2875	113	P01	767	2875
22	S21	-2240	-612	68	V3	2147	-2875	114	P02	631	2875
23	S22	-2240	-747	69	V4	2283	-2875	115	P03	496	2875
24	S23	-2240	-883	70	V5	2240	-2479	116	P04	360	2875
25	S24	-2240	-1018	71	VLCD	2240	-2344	117	P05	225	2875
26	S25	-2240	-1154	72	VOUT2	2240	-2208	118	P06	89	2875
27	S26	-2240	-1290	73	CUP2	2240	-2072	119	P07	-47	2875
28	S27	-2240	-1425	74	CUP1	2240	-1937	120	P20	-182	2875
29	S28	-2240	-1561	75	VSS	2240	-1481	121	P21	-318	2875
30	S29	-2240	-1696	76	P40	2240	-1345	122	P22	-453	2875
31	S30	-2240	-1832	77	P41	2240	-1210	123	P23	-589	2875
32	S31	-2240	-1968	78	P42	2240	-1074	124	P24	-725	2875
33	S32	-2240	-2103	79	P43	2240	-938	125	P25	-860	2875
34	S33	-2240	-2239	80	P44	2240	-803	126	P26	-996	2875
35	S34	-2240	-2374	81	P46	2240	-667	127	P27	-1131	2875
36	S35	-2192	-2875	82	P47	2240	-532	128	ADLC	-1267	2875
37	S36	-2056	-2875	83	P70	2240	-396	129	$\overline{\text{EROE}}$	-1403	2875
38	S37	-1921	-2875	84	P71	2240	-260	130	$\overline{\text{RES}}$	-1538	2875
39	S38	-1785	-2875	85	P72	2240	-125	131	XT1	-1674	2875
40	S39	-1649	-2875	86	P73	2240	11	132	XT2	-1809	2875
41	S40	-1514	-2875	87	P10	2240	146	133	VSS	-1945	2875
42	S41	-1378	-2875	88	P11	2240	282	134	CF1	-2081	2875
43	S42	-1243	-2875	89	P12	2240	418	135	CF2	-2216	2875
44	S43	-1107	-2875	90	P13	2240	553				
45	S44	-971	-2875	91	P14	2240	689				
46	S45	-836	-2875	92	P15	2240	824				

The values (X, Y) indicate the coordinates of each pad center with the center of the chip as the origin.  
Connect the substrate of chip to VSS or open.

System Block Diagram

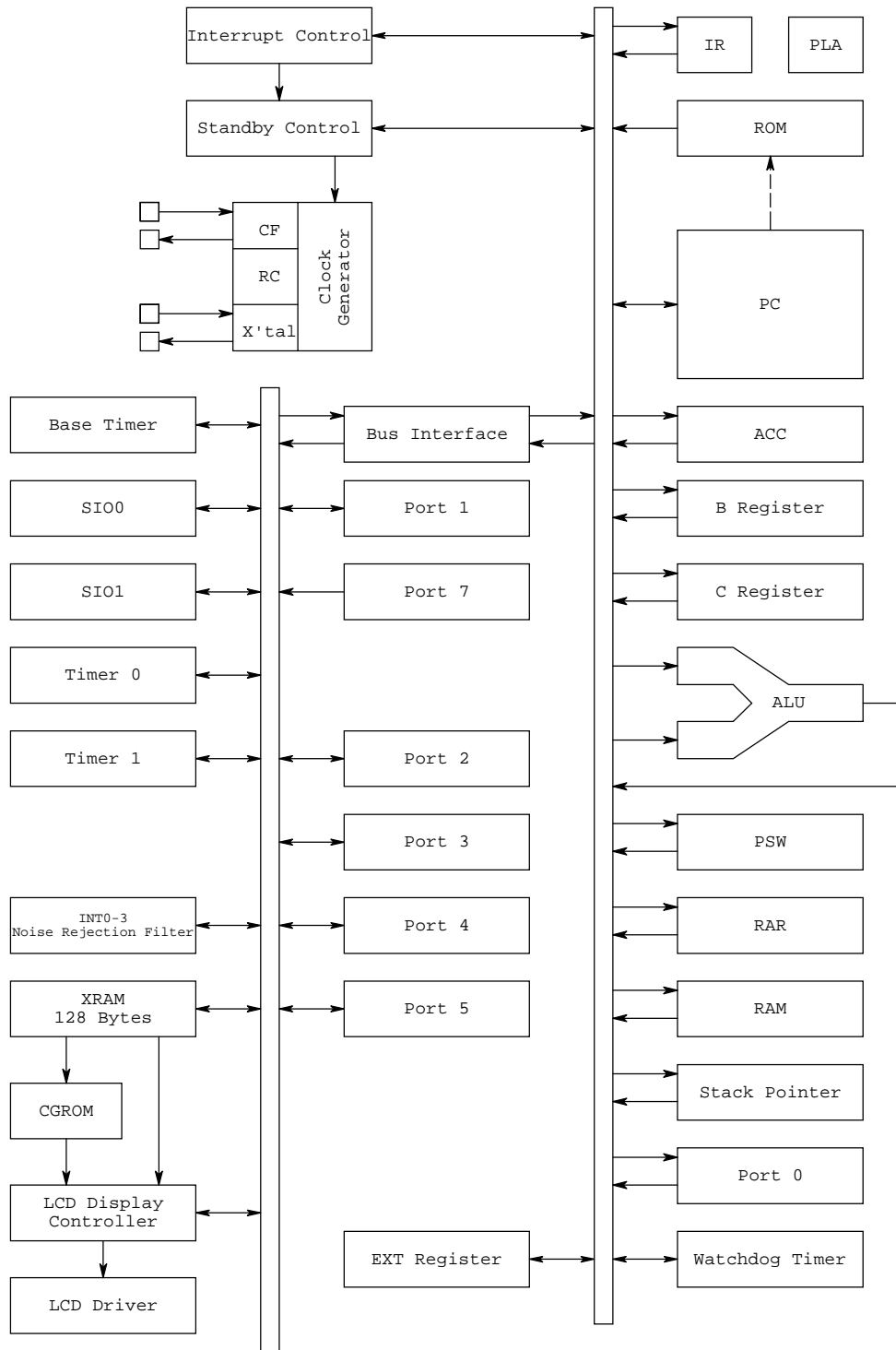



Pin Description

Name	No.	I/O	Function description	Option																
VSS	75,133	-	Power terminal (-)	-																
VDD	1,103	-	Power terminal (+)	-																
VLCD	71	-	Power terminal (+) for LCD driver *2	-																
V1 to V5	66-70	-	Voltage supply terminals to LCD drivers *2	-																
VOUT2	72	-	Output terminals for doubler $VOUT2 \cong 2X(VDD-VSS)$	-																
CUP1,2	74,73	-	Capacitor connecting terminals for doubler, tripler	-																
Port0 P00 to P07	112-119	I/O	<ul style="list-style-type: none"> <li>•8-bit input/output port</li> <li>•Input/output can be specified in 4-bit</li> <li>•External memory mode</li> <li>1. EXT resistor bit 2=0 Address output of lower 8-bit, input/output of data</li> <li>2. EXT resistor bit 2=1 Input/output of data</li> <li>•Input for key interrupt (P30INT=0) *1</li> </ul>	<ul style="list-style-type: none"> <li>•Pull-up resistor : Provided/Not provided</li> <li>•Output form : CMOS/N-ch open drain</li> </ul>																
Port1 P10 to P17	87-94	I/O	<ul style="list-style-type: none"> <li>•8-bit input/output port</li> <li>•Input/output can be specified in a bit</li> <li>•Another functions</li> </ul> <table border="1" style="margin-left: 20px;"> <tr><td>P10</td><td>SIO0 data output</td></tr> <tr><td>P11</td><td>SIO0 data input, bus input/output</td></tr> <tr><td>P12</td><td>SIO0 clock input/output</td></tr> <tr><td>P13</td><td>SIO1 data output</td></tr> <tr><td>P14</td><td>SIO1 data input, bus input/output</td></tr> <tr><td>P15</td><td>SIO1 clock input/output</td></tr> <tr><td>P16</td><td>Buzzer output</td></tr> <tr><td>P17</td><td>Timer 1 output (PWM output)</td></tr> </table>	P10	SIO0 data output	P11	SIO0 data input, bus input/output	P12	SIO0 clock input/output	P13	SIO1 data output	P14	SIO1 data input, bus input/output	P15	SIO1 clock input/output	P16	Buzzer output	P17	Timer 1 output (PWM output)	<ul style="list-style-type: none"> <li>•Output form : CMOS/N-ch open drain</li> </ul>
P10	SIO0 data output																			
P11	SIO0 data input, bus input/output																			
P12	SIO0 clock input/output																			
P13	SIO1 data output																			
P14	SIO1 data input, bus input/output																			
P15	SIO1 clock input/output																			
P16	Buzzer output																			
P17	Timer 1 output (PWM output)																			
Port2 P20 to P27	120-127	I/O	<ul style="list-style-type: none"> <li>•8-bit input/output port</li> <li>•Input/output can be specified in a bit</li> <li>•External memory mode</li> <li>Address output of upper 8-bit</li> </ul>	<ul style="list-style-type: none"> <li>•Output form : CMOS/N-ch open drain</li> </ul>																
Port3 P30 to P37	104-111	I/O	<ul style="list-style-type: none"> <li>•8-bit input/output port</li> <li>•Input/output in a bit</li> <li>•External memory mode</li> <li>1. EXT resistor bit 2=0 : input/output port</li> <li>2. EXT resistor bit 2=1 : address output of lower 8-bit for external memory</li> <li>•Input for key interrupt (P30INT=L) *1</li> </ul>	<ul style="list-style-type: none"> <li>•Pull-up resistor : Provided/Not provided</li> <li>•Output form : CMOS/N-ch open drain</li> </ul>																

\*1 P30INT : Bit 0 of Port 3 interrupt control register.

\*2 The structure of the LCD power supply is shown below.

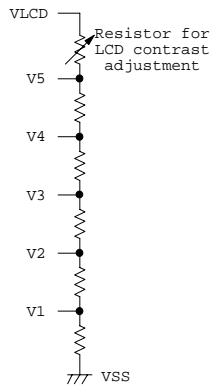

Note : If the microcontroller is operated at 3V, the voltage doubler output (VOUT2) should be connected to the LCD power terminal (VLCD).  
(or the output of an external voltage doubler should be connected to VLCD)

Name	No.	I/O	Function description	Option																																											
Port4 P40 to P44 P46, P47	76-80 81,82	I/O	<ul style="list-style-type: none"> <li>•7-bit input/output port</li> <li>•Input/output can be specified each upper 2 bits and lower 5 bits</li> <li>•Another functions                             <table border="1" style="margin-left: 20px;"> <tr><td>P40</td><td>CL1</td><td>Latch clock</td></tr> <tr><td>P41</td><td>CL2</td><td>Shift clock</td></tr> <tr><td>P42</td><td>DO</td><td>Output data</td></tr> <tr><td>P43</td><td>M</td><td>Alternate signal</td></tr> <tr><td>P44</td><td>FRM</td><td>Frame signal</td></tr> <tr><td>P46</td><td><math>\overline{RD}</math></td><td>Read signal</td></tr> <tr><td>P47</td><td><math>\overline{WR}</math></td><td>Write signal</td></tr> </table> </li> </ul> <p>(P40-P44 : LCD display extend signal, P46, P47 : External RAM access signal)</p>	P40	CL1	Latch clock	P41	CL2	Shift clock	P42	DO	Output data	P43	M	Alternate signal	P44	FRM	Frame signal	P46	$\overline{RD}$	Read signal	P47	$\overline{WR}$	Write signal	<ul style="list-style-type: none"> <li>•Pull-up resistor : Provided/Not provided</li> <li>•Output form : CMOS/N-ch open drain</li> </ul>																						
P40	CL1	Latch clock																																													
P41	CL2	Shift clock																																													
P42	DO	Output data																																													
P43	M	Alternate signal																																													
P44	FRM	Frame signal																																													
P46	$\overline{RD}$	Read signal																																													
P47	$\overline{WR}$	Write signal																																													
Port5 P50 to P57	102-95	I/O	<ul style="list-style-type: none"> <li>•8-bit input/output port</li> <li>•Input/output in bit unit</li> <li>•External memory mode                             <ol style="list-style-type: none"> <li>1. EXT resistor bit 3=0 : input/output</li> <li>2. EXT resistor bit 3=1 : bank address output for external memory</li> </ol> </li> </ul>	<ul style="list-style-type: none"> <li>•Pull-up resistor : Provided/Not provided</li> <li>•Output form : CMOS/N-ch open drain</li> </ul>																																											
Port7 P70 to P73	83-86	I	<ul style="list-style-type: none"> <li>•4-bit input port</li> <li>•Another functions                             <table border="1" style="margin-left: 20px;"> <tr><td>P70</td><td>INT0 input/HOLD release/N-ch Tr. output for watchdog timer</td></tr> <tr><td>P71</td><td>INT1 input/HOLD release</td></tr> <tr><td>P72</td><td>INT2 input/timer 0 event input</td></tr> <tr><td>P73</td><td>INT3 input with noise filter/timer 0 event input</td></tr> </table> </li> <li>•Interrupt received form, vector address                             <table border="1" style="margin-left: 20px;"> <thead> <tr> <th></th> <th>leading</th> <th>trailing</th> <th>leading &amp; trailing</th> <th>high level</th> <th>low level</th> <th>vector</th> </tr> </thead> <tbody> <tr> <td>INT0</td> <td>enable</td> <td>enable</td> <td>disable</td> <td>enable</td> <td>enable</td> <td>03H</td> </tr> <tr> <td>INT1</td> <td>enable</td> <td>enable</td> <td>disable</td> <td>enable</td> <td>enable</td> <td>0BH</td> </tr> <tr> <td>INT2</td> <td>enable</td> <td>enable</td> <td>enable</td> <td>disable</td> <td>disable</td> <td>13H</td> </tr> <tr> <td>INT3</td> <td>enable</td> <td>enable</td> <td>enable</td> <td>disable</td> <td>disable</td> <td>1BH</td> </tr> </tbody> </table> </li> </ul>	P70	INT0 input/HOLD release/N-ch Tr. output for watchdog timer	P71	INT1 input/HOLD release	P72	INT2 input/timer 0 event input	P73	INT3 input with noise filter/timer 0 event input		leading	trailing	leading & trailing	high level	low level	vector	INT0	enable	enable	disable	enable	enable	03H	INT1	enable	enable	disable	enable	enable	0BH	INT2	enable	enable	enable	disable	disable	13H	INT3	enable	enable	enable	disable	disable	1BH	<ul style="list-style-type: none"> <li>•Pull-up resistor : Provided/Not provided</li> </ul>
P70	INT0 input/HOLD release/N-ch Tr. output for watchdog timer																																														
P71	INT1 input/HOLD release																																														
P72	INT2 input/timer 0 event input																																														
P73	INT3 input with noise filter/timer 0 event input																																														
	leading	trailing	leading & trailing	high level	low level	vector																																									
INT0	enable	enable	disable	enable	enable	03H																																									
INT1	enable	enable	disable	enable	enable	0BH																																									
INT2	enable	enable	enable	disable	disable	13H																																									
INT3	enable	enable	enable	disable	disable	1BH																																									

Name	No.	I/O	Function description	Option
C1 to C16	65-50	O	LCD output terminals for common	-
S1 to S48	2-49	O	LCD output terminals for segment	LCD output terminals : segment/common
$\overline{\text{RES}}$	130	I	Reset	-
ADLC	128	O	Address control signal for external memory	-
$\overline{\text{EROE}}$	129	O	Enable signal of external ROM output	-
XT1	131	I	Input for 32.768kHz crystal oscillation In case of non use, connect to VDD	-
XT2	132	O	Output for 32.768kHz crystal oscillation In case of non use, should be left unconnected	-
CF1	134	I	Input for ceramic resonator oscillation In case of non use, connect to VDD	-
CF2	135	O	Output for ceramic resonator oscillation In case of non use, should be left unconnected	-

\* Port options can be specified in a bit.

\* A state of port at initial

Pin name	Input/output mode	A state of pull-up resistor specified at pull-up option
Port 0, 7	Input	Fixed pull-up resistor exist
Ports 1, 2 Ports 3, 5	Input	Programmable pull-up resistor OFF
Port 4	Input	Programmable pull-up resistor ON

Name	Output level
C1 to C16	VSS (Display OFF)
S1 to S48	VSS (Display OFF)

1. Absolute Maximum Ratings at VSS=0V and Ta=25°C

Parameter		Symbol	Pins	Conditions	VDD[V]	Ratings			unit	
						min.	typ.	max.		
Supply voltage		VDDMAX	VDD			-0.3		+7.0	V	
Input voltage		VI(1)	•Ports 71,72,73 •RES			-0.3		VDD+0.3		
		VI(2)	VLCD			-0.3		+7.0		
Output voltage		VO(1)	•C1 to C16 •S1 to S48			-0.3		VLCD+0.3		
		VO(2)	•VOUT2 •CUP1,CUP2			-0.3		VDD+0.3		
		VO(3)	ADLC, EROE			-0.3		VDD+0.3		
Input/output voltage		VIO(1)	•Ports 0,1,2,3,4,5 •Port 70			-0.3		VDD+0.3	mA	
High level output current	Peak output current	IOPH(1)	•Ports 0,1,2,3,4,5 •ADLC, EROE	•CMOS output •At each pin		-4				
	Total output current	ΣIOAH(1)	•Ports 0,2,3 •C1-C16,S1-S48 •ADLC, EROE	Total all pins		-25				
		ΣIOAH(2)	Ports 1, 4, 5	Total all pins		-25				
Low level output current	Peak output current	IOPL(1)	•Ports 0,1,2,3,4,5 •ADLC, EROE	At each pin				20		
		IOPL(2)	Port 70	At each pin				15		
	Total output current	ΣIOAL(1)	Port 0	Total all pins						40
		ΣIOAL(2)	•Port 2 •ADLC, EROE	Total all pins						40
		ΣIOAL(3)	Port 3	Total all pins						40
		ΣIOAL(4)	Ports 1, 5	Total all pins						40
		ΣIOAL(5)	Port 4	Total all pins					40	
		ΣIOAL(6)	Port 70	Total all pins					15	
ΣIOAL(7)	C1-C16,S1-S48	Total all pins					30			
Operating temperature range		Topr				-30		+70	°C	
Storage temperature range		Tstg				-65		+150		

Notes :

The specifications above are for a die mounted in a QIC160 type package.  
 However, we ship this product as a die only, not a package chip.  
 Therefore, the operational characteristics may vary depending on the user's packaging techniques.

## 2. Recommended Operating Range at Ta=-30°C to +70°C, VSS=0V

Parameter	Symbol	Pins	Conditions	Ratings			unit	
				VDD[V]	min.	typ.		max.
Operating supply voltage range	VDD(1)	VDD	0.98 $\mu$ s $\leq$ tCYC $\leq$ 400 $\mu$ s		4.5		6.0	V
	VDD(2)		1.9 $\mu$ s $\leq$ tCYC $\leq$ 400 $\mu$ s		4.5		6.0	
	VDD(3)		3.9 $\mu$ s $\leq$ tCYC $\leq$ 400 $\mu$ s		2.5		6.0	
Hold voltage	VHD	VDD	RAMs and the registers hold voltage at HOLD mode.		2.0		6.0	
LCD display voltage	VLCD	VLCD		2.5-3.0	VDD		6.0	
				3.0-6.0	VDD		6.0	
Input high voltage	VIH(1)	Port 0 (Schmitt)	Output disable	2.5-6.0	0.4VDD +0.9		VDD	
	VIH(2)	•Ports 1,2,3,4,5 •Ports 72,73 (Schmitt)	Output disable	2.5-6.0	0.75VDD		VDD	
	VIH(3)	•Port 70 for Port input/interrupt •Port 71 •RES (Schmitt)	Output N-channel Tr. OFF	2.5-6.0	0.75VDD		VDD	
	VIH(4)	Port 70 for watchdog timer	Output N-channel Tr. OFF	2.5-6.0	0.9VDD		VDD	
Input low voltage	VIL(1)	Port 0 (Schmitt)	Output disable	2.5-6.0	VSS		0.2VDD	
	VIL(2)	•Ports 1,2,4,5 •Ports 72,73 (Schmitt)	Output disable	2.5-6.0	VSS		0.25VDD	
	VIL(3)	•Port 70 Port input/interrupt •Port 71 •RES	Output N-channel Tr. OFF	2.5-6.0	VSS		0.25VDD	
	VIL(4)	Port 70 for watchdog timer	Output N-channel Tr. OFF	2.5-6.0	VSS		0.8VDD -1.0	
Operation cycle time	tCYC		excluding external memory access function	4.5-6.0	0.98		400	$\mu$ s
				2.5-6.0	3.9		400	
			for external memory access	4.5-6.0	1.9		400	
				2.5-6.0	3.9		400	
Oscillation frequency range (Note 1)	FmCF(1)	CF1, CF2	•12MHz (ceramic resonator oscillation) •Refer to figure 1	4.5-6.0	11.76	12	12.24	MHz
	FmCF(2)	CF1, CF2	•6MHz (ceramic resonator oscillation) •Refer to figure 1	4.5-6.0	5.88	6	6.12	
	FmCF(3)	CF1, CF2	•3MHz (ceramic resonator oscillation) •Refer to figure 1	2.5-6.0	2.94	3	3.06	
	FmRC		RC oscillation	2.5-6.0	0.4	0.8	2.0	
	FsXtal	XT1, XT2	•32.768kHz (crystal oscillation) •Refer to figure 2	2.5-6.0		32.768		kHz

Continue.

Parameter	Symbol	Pins	Conditions	Ratings			unit	
				VDD[V]	min.	typ.		max.
Oscillation stabilizing time period (Note 1)	tmsCF(1)	CF1, CF2	•12MHz (ceramic resonator oscillation) •Refer to figure 3	4.5-6.0		0.02	0.3	ms
	tmsCF(2)	CF1, CF2	•6MHz (ceramic resonator oscillation) •Refer to figure 3	4.5-6.0		0.02	0.3	
	tmsCF(3)	CF1, CF2	•3MHz (ceramic resonator oscillation) •Refer to figure 3	4.5-6.0		0.1	1	
				2.5-6.0		0.1	3	
tssXtal	XT1, XT2	•32.768kHz (crystal oscillation) •Refer to figure 3	4.5-6.0		1	1.5	s	
			2.5-6.0		1	3		

(Note 1) The oscillation constant is shown on table 1 and table 2.

## 3. Electrical Characteristics at Ta=-30°C to +70°C, VSS=0V

Parameter	Symbol	Pins	Conditions	Ratings			unit	
				VDD[V]	min.	typ.		max.
Input high current	IIH(1)	•Ports 1,2,3,4,5 •Port 0 without pull-up MOS Tr.	•Output disable •Pull-up MOS Tr. OFF •VIN=VDD (including the off-leak current of the output Tr.)	2.5-6.0			1	μA
	IIH(2)	Port 7 without pull-up MOS Tr.	•Output Nch Tr. OFF •VIN=VDD (including the off-leak current of the output Tr.)	2.5-6.0			1	
	IIH(3)	$\overline{\text{RES}}$	VIN=VDD	2.5-6.0			1	
Input low current	IIL(1)	•Ports 1,2,3,4,5 •Port 0 without pull-up MOS Tr.	•Output disable •Pull-up MOS Tr. OFF •VIN=VSS (including the off-leak current of the output Tr.)	2.5-6.0	-1			
	IIL(2)	Port 7 without pull-up MOS Tr.	•Output Nch Tr. OFF •VIN=VSS (including the off-leak current of the output Tr.)	2.5-6.0	-1			
	IIL(3)	$\overline{\text{RES}}$	VIN=VSS	2.5-6.0	-1			
Output high voltage	VOH(1)	Port 0 of CMOS output	IOH=-10mA	4.5-6.0	VDD-2.2			V
	VOH(2)		IOH=-1mA	2.5-6.0	VDD-0.4			
	VOH(3)	•Ports 1,2,3,4,5 of CMOS output •ADLC, $\overline{\text{EROE}}$	IOH=-1.0mA	4.5-6.0	VDD-1			
	VOH(4)		IOH=-0.1mA	2.5-6.0	VDD-0.5			
Output low voltage	VOL(1)	•Ports 0,1,2,3,4,5 •ADLC, $\overline{\text{EROE}}$	IOL=10mA	4.5-6.0			1.5	
	VOL(2)		IOL=1.6mA	4.5-6.0			0.4	
	VOL(3)		•IOL=1.0mA •The current of any measurement pin is not over 1mA.	2.5-6.0			0.4	
	VOL(4)	Port 70	IOL=1mA	4.5-6.0			0.4	
	VOL(5)		IOL=0.5mA	2.5-6.0			0.4	
Pull-up MOS Tr. resistor	Rpu	•Ports 0,1,2,3,4,5 •Port 7	VOH=0.9VDD	4.5-6.0	15	40	70	kΩ
				2.5-4.5	25	60	120	
Hysteresis voltage	VHIS	•Ports 0,1,2,3,4,5 •Port 7 • $\overline{\text{RES}}$	Output disable	2.5-6.0		0.1VDD		V
Pin capacitance	CP	All pins	•f=1MHz •Unmeasurement terminals for the input are set to VSS level. •Ta=25°C	2.5-6.0		10		pF

4. Serial Input/Output Characteristics at Ta=-30°C to +70°C, VSS=0V

Parameter		Symbol	Pins	Conditions	VDD[V]	Ratings			unit	
						min.	typ.	max.		
Serial clock	Input clock	Cycle	tCKCY(1)	SCK0, SCK1	Refer to figure 5.	2.5-6.0	2			tCYC
		Low Level pulse width	tCKL(1)				1			
		High Level pulse width	tCKH(1)				1			
	Output clock	Cycle	tCKCY(2)	SCK0, SCK1	<ul style="list-style-type: none"> <li>•Use pull-up resistor (1kΩ) when Nch open-drain output.</li> <li>•Refer to figure 5.</li> </ul>	2.5-6.0	2			
		Low Level pulse width	tCKL(2)					1/2 tCKCY		
		High Level pulse width	tCKH(2)					1/2 tCKCY		
Serial input	Data set up time	tICK	<ul style="list-style-type: none"> <li>•SI0,SI1</li> <li>•SB0,SB1</li> </ul>	<ul style="list-style-type: none"> <li>•Data set-up to SCK0,1</li> <li>•Data hold from SCK0,1</li> <li>•Refer to figure 5.</li> </ul>	4.5-6.0	0.1			μs	
					2.5-6.0	0.4				
	Data hold time	tCKI		4.5-6.0	0.1					
				2.5-6.0	0.4					
Serial output	Output delay time (Serial clock is external clock)	tCKO(1)	<ul style="list-style-type: none"> <li>•SO0,SO1</li> <li>•SB0,SB1</li> </ul>	<ul style="list-style-type: none"> <li>•Data set-up to SCK0,1</li> <li>•Use pull-up resistor (1kΩ) when Nch open-drain output.</li> <li>•Refer to figure 5.</li> </ul>	4.5-6.0			7/12 tCYC +0.2		
					2.5-6.0			7/12 tCYC +1		
	Output delay time (Serial clock is internal clock)	tCKO(2)		<ul style="list-style-type: none"> <li>•SO0,SO1</li> <li>•SB0,SB1</li> </ul>	<ul style="list-style-type: none"> <li>•Data hold from SCK0,1</li> <li>•Use pull-up resistor (1kΩ) when Nch open-drain output.</li> <li>•Refer to figure 5.</li> </ul>	4.5-6.0			1/3 tCYC +0.2	
						2.5-6.0			1/3 tCYC +1	



## 5. Pulse Input Conditions at Ta=-30°C to +70°C, VSS=0V

Parameter	Symbol	Pins	Conditions	Ratings			unit	
				VDD[V]	min.	typ.		max.
High/low level pulse width	tPIH(1) tPIL(1)	•INT0, INT1 •INT2/T0IN •Refer to figure 6	•Interrupt acceptable •Timer0-countable	2.5-6.0	1			tCYC
	tPIH(2) tPIL(2)	•INT3/T0IN (The noise rejection clock is selected to 1/1.) •Refer to figure 6	•Interrupt acceptable •Timer0-countable	2.5-6.0	2			
	tPIH(3) tPIL(3)	•INT3/T0IN (The noise rejection clock is selected to 1/16.) •Refer to figure 6	•Interrupt acceptable •Timer0-countable	2.5-6.0	32			
	tPIH(4) tPIL(4)	•INT3/T0IN (The noise rejection clock is selected to 1/64.) •Refer to figure 6	•Interrupt acceptable •Timer0-countable	2.5-6.0	128			
	tPIL(5)	• $\overline{\text{RES}}$ •Refer to figure 6	Reset acceptable	2.5-6.0	200			μs

6. Current Dissipation Characteristics at Ta=-30°C to +70°C, VSS=0V

Parameter	Symbol	Pins	Conditions	Ratings			unit			
				OCR7	VDD[V]	min.		typ.	max.	
Current drain during basic operation (Note 2)	IDDOP(1)	VDD	<ul style="list-style-type: none"> <li>•FmCF=12MHz Ceramic resonator oscillation</li> <li>•FsXtal=32.768kHz crystal oscillation</li> <li>•System clock : 12MHz</li> <li>•Internal RC oscillation stops</li> </ul>	0	4.5-6.0		10	25	mA	
	IDDOP(2)		<ul style="list-style-type: none"> <li>•FmCF=6MHz Ceramic resonator oscillation</li> <li>•FsXtal=32.768kHz crystal oscillation</li> <li>•System clock : 6MHz</li> <li>•Internal RC oscillation stops</li> </ul>	1	4.5-6.0		10	25		
	IDDOP(3)		<ul style="list-style-type: none"> <li>•FmCF=3MHz Ceramic resonator oscillation</li> </ul>	0	4.5-6.0		3	9		
	IDDOP(4)			1			6	15		
	IDDOP(5)		<ul style="list-style-type: none"> <li>•FsXtal=32.768kHz crystal oscillation</li> <li>•System clock : 3MHz</li> <li>•Internal RC oscillation stops</li> </ul>	0	2.5-4.5		1.5	5		
	IDDOP(6)		<ul style="list-style-type: none"> <li>•FmCF=0Hz (when oscillation stops)</li> </ul>	0	4.5-6.0		0.7	3.4		
	IDDOP(7)			1			1.2	4.5		
	IDDOP(8)			0		2.5-4.5		0.4		2.8
	IDDOP(9)		<ul style="list-style-type: none"> <li>•FsXtal=32.768kHz crystal oscillation</li> <li>•System clock : RC oscillation</li> </ul>	1			0.8	3.6		
	IDDOP(10)		<ul style="list-style-type: none"> <li>•FmCF=0Hz (when oscillation stops)</li> <li>•FsXtal=32.768kHz crystal oscillation</li> <li>•System clock : 32.768kHz</li> <li>•Internal RC oscillation stops</li> </ul>	0	4.5-6.0		38	150		μA
	IDDOP(11)			1			60	300		
	IDDOP(12)			0		2.5-4.5		15		
	IDDOP(13)			1				25	120	

\*OSCR : Bit 7 of the oscillation control register.

Continue.

Parameter	Symbol	Pins	Conditions	Ratings			unit				
				OCR7	VDD[V]	min.		typ.	max.		
Current drain in HALT mode (Note 2)	IDDHALT(1)	VDD	<ul style="list-style-type: none"> <li>•HALT mode</li> <li>•FmCF=12MHz</li> <li>  Ceramic resonator oscillation</li> <li>•FsXtal=32.768kHz</li> <li>  crystal oscillation</li> <li>•System clock : 12MHz</li> <li>•Internal RC oscillation stops</li> </ul>	0	4.5-6.0		5.0	14	mA		
	IDDHALT(2)		<ul style="list-style-type: none"> <li>•HALT mode</li> <li>•FmCF=6MHz</li> <li>  Ceramic resonator oscillation</li> <li>•FsXtal=32.768kHz</li> <li>  crystal oscillation</li> <li>•System clock : 6MHz</li> <li>•Internal RC oscillation stops</li> </ul>	1	4.5-6.0		5.0	14			
	IDDHALT(3)		<ul style="list-style-type: none"> <li>•HALT mode</li> <li>•FmCF=3MHz</li> <li>  Ceramic resonator oscillation</li> <li>•FsXtal=32.768kHz</li> <li>  crystal oscillation</li> <li>•System clock : 3MHz</li> <li>•Internal RC oscillation stops</li> </ul>	0	4.5-6.0		2.3	7			
	IDDHALT(4)			1			4.5	15			
	IDDHALT(5)		<ul style="list-style-type: none"> <li>•HALT mode</li> <li>•FmCF=0Hz</li> <li>  Ceramic resonator oscillation stops</li> <li>•FsXtal=32.768kHz</li> <li>  crystal oscillation</li> <li>•System clock : RC oscillation</li> </ul>	0	2.5-4.5		0.8	4			
	IDDHALT(6)			0		4.5-6.0		400		1600	
	IDDHALT(7)			1				600		2400	
	IDDHALT(8)			0			2.5-4.5			200	1300
	IDDHALT(9)		1		350			1500			
	IDDHALT(10)		<ul style="list-style-type: none"> <li>•HALT mode</li> <li>•FmCF=0Hz</li> <li>  Ceramic resonator oscillation stops</li> <li>•FsXtal=32.768kHz</li> <li>  crystal oscillation</li> <li>•System clock : 32.768kHz</li> <li>•Internal RC oscillation stops</li> </ul>	0	4.5-6.0		25	100		μA	
	IDDHALT(11)			1			36	140			
	IDDHALT(12)			0		2.5-4.5		8			55
	IDDHALT(13)			1				12			85
Current drain in HOLD mode (Note 2)	IDDHOLD(1)	VDD	HOLD mode		4.5-6.0		0.05	30			
	IDDHOLD(2)				2.5-4.5		0.02	20			

(Note 2) The currents of the output transistors, pull-up transistors and the LCD bleeder resistors are ignored.  
Refer to figure 7.

7. LCD Voltage and LCD Driver Characteristics at Ta=-30°C to +70°C, VSS=0V

Parameter	Symbol	Pins, Conditions	Ratings				unit	
			VDD[V]	min.	typ.	max.		
VX-Ci drop voltage(X : 1 to 5) (i : 1 to 16)	VD1	<ul style="list-style-type: none"> <li>•Only a Ci terminal for -15μA</li> <li>•LCD display ON</li> <li>•1/5 bias</li> <li>•V5=VDD</li> </ul>	2.9			120	mV	
			5.0			200		
VX-Ci drop voltage(X : 1 to 5) (i : 1 to 16)	VD2	<ul style="list-style-type: none"> <li>•Only a Ci terminal for +15μA</li> <li>•LCD display ON</li> <li>•1/5 bias</li> <li>•V5=VDD</li> </ul>	2.9	-120				
			5.0	-200				
VX-Si drop voltage(X : 1 to 5) (i : 1 to 48)	VD3	<ul style="list-style-type: none"> <li>•Only a Si terminal for -15μA</li> <li>•LCD display ON</li> <li>•1/5 bias</li> <li>•V5=VDD</li> </ul>	2.9			120		
			5.0			200		
VX-Si drop voltage(i : 1 to 5) (i : 1 to 48)	VD4	<ul style="list-style-type: none"> <li>•Only a Si terminal for +15μA</li> <li>•LCD display ON</li> <li>•1/5 bias</li> <li>•V5=VDD</li> </ul>	2.9	-120				
			5.0	-200				
V4 output voltage	VV4	<ul style="list-style-type: none"> <li>•LCD clock frequency=0Hz</li> <li>•LCD display ON</li> <li>•1/5 bias</li> <li>•V5=VDD</li> <li>•Refer to figure 9</li> </ul>	2.9	0.75VDD	0.80VDD	0.85VDD	V	
V3 output voltage	VV3		5.0					
			2.9	0.55VDD	0.60VDD	0.65VDD		
V2 output voltage	VV2		5.0					
			2.9	0.35VDD	0.40VDD	0.45VDD		
V1 output voltage	VV1		5.0					
		2.9	0.15VDD	0.20VDD	0.25VDD			
LCD display current	ILCD1	<ul style="list-style-type: none"> <li>•LCD display ON</li> <li>•1/5 bias</li> <li>•VLCD=VDD</li> <li>•V1-V5 are opened</li> <li>•Refer to figure 8</li> </ul>	20kΩ mode	5	25	50	100	μA
			2.9	15	29	60		
	ILCD2		4KΩ mode	5	125	250	500	
			2.9	75	150	300		
Step-up output voltage	VOUT2	<ul style="list-style-type: none"> <li>•V1-V5 resistor=20kΩ</li> <li>•LCD display ON</li> <li>•LVCR0=1 (doubler)</li> <li>•VOUT2</li> <li>•VDD=2.5 to 3.0V</li> <li>•C5=C6=0.1μF</li> <li>•Refer to figure 10</li> </ul>	<ul style="list-style-type: none"> <li>•IL=100μA</li> <li>•step-up clock : RC oscillation</li> </ul>	2.7	4.4	4.6	5.4	V
				3	5.6	5.8	6.0	
			<ul style="list-style-type: none"> <li>•IL=500μA</li> <li>•step-up clock : RC oscillation</li> </ul>	2.7	4.2	4.5	5.4	
				3	5.2	5.6	6.0	
			<ul style="list-style-type: none"> <li>•IL=100μA</li> <li>•step-up clock : crystal oscillation</li> </ul>	2.7	4.3	4.5	5.4	
				3	5.4	5.7	6.0	
			<ul style="list-style-type: none"> <li>•IL=500μA</li> <li>•step-up clock : crystal oscillation</li> </ul>	2.7	4.0	4.3	5.4	
				3	5.0	5.4	6.0	
Contrast current (VLCD terminal)	ILC1	<ul style="list-style-type: none"> <li>•LCD display ON</li> <li>•V5=VDD-0.5V</li> <li>•VLCD=VDD</li> <li>•Refer to figure 11</li> </ul>	VCCR=1	5	0.8	1.6	3.2	mA
	ILC2		VCCR=2	5	0.4	0.8	1.6	
	ILC3		VCCR=4	5	0.2	0.4	0.8	
	ILC4		VCCR=8	5	0.1	0.2	0.4	μA
	ILC5		VCCR=10H	5	0.05	0.1	0.2	

VCCR : The LCD contrast control register

LVCR0 : Bit 0 of the LCD bias control register

Table 1. Ceramic resonator oscillation recommended constant (main clock)

Oscillation type	Maker	Oscillator	C1	C2
12MHz ceramic resonator oscillation	Murata	CSA12.0MT	33pF	33pF
		CST12.00MTW	on chip	
	Kyocera	KBR-12.0M	33pF	33pF
6MHz ceramic resonator oscillation	Murata			
			on chip	
	Kyocera			
3MHz ceramic resonator oscillation	Murata	CSA3.0MG	33pF	33pF
		CST3.0MGW	on chip	
	Kyocera	KBR-3.0MS	47pF	47pF

\* Both C1 and C2 must use K rank ( $\pm 10\%$ ) and SL characteristics.

Table 2. Crystal oscillation guaranteed constant (sub clock)

Oscillation type	Maker	Oscillator	C3	C4
32.768kHz crystal oscillation	CITIZEN	CFS-308	18pF	18pF
	SII	DT-VT-200	18pF	18pF

\* Both C3 and C4 must use J rank ( $\pm 5\%$ ) and CH characteristics.

(It is about the application which is not in need of high precision. Use K rank ( $\pm 10\%$ ) and SL characteristics.)

- (Notes)
- Since the circuit pattern affects the oscillation frequency, place the oscillation-related parts as close to the oscillation pins as possible with the shortest possible pattern length.
  - If you use other oscillators herein, we provide no guarantee for the characteristics.

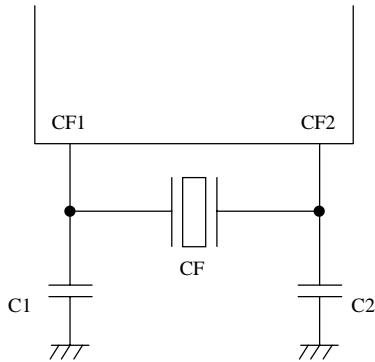

Figure 1 Ceramic oscillation circuit

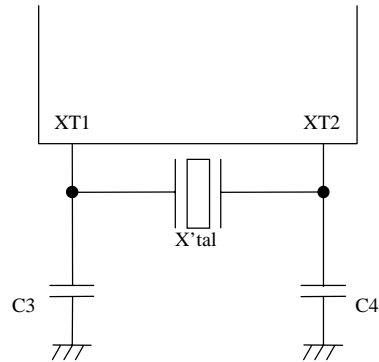

Figure 2 Crystal oscillation circuit

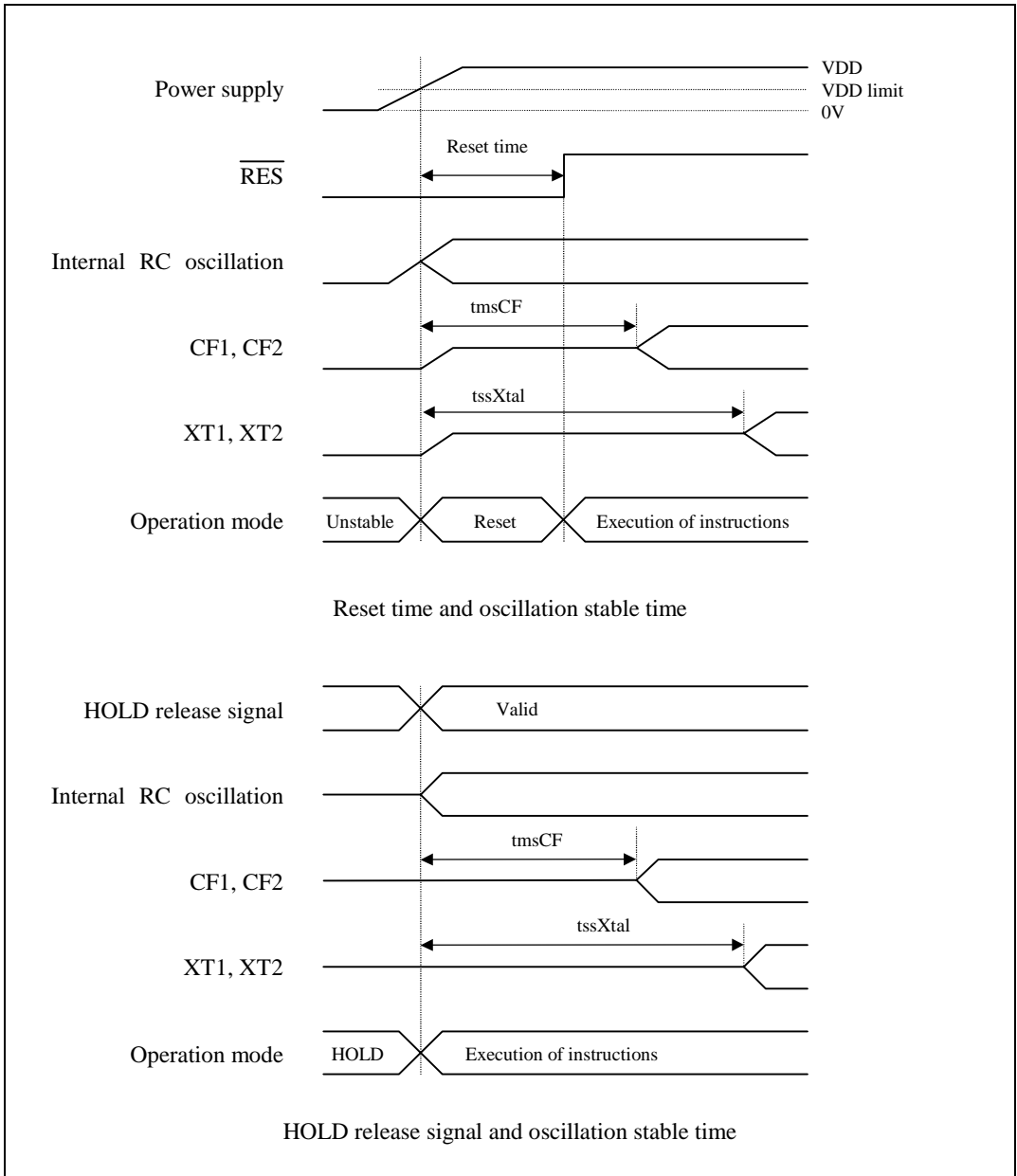
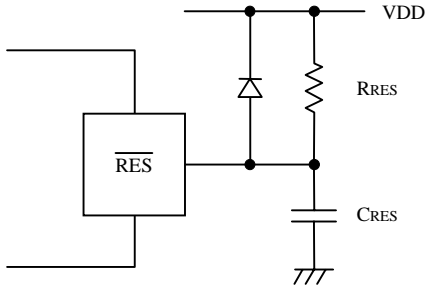

Figure 3 Oscillation stable time



(Note) Fix the value of CRES, RRES that is sure to reset until 200 $\mu$ s, after Power supply has been over inferior limit of supply voltage.

Figure 4 Reset circuit

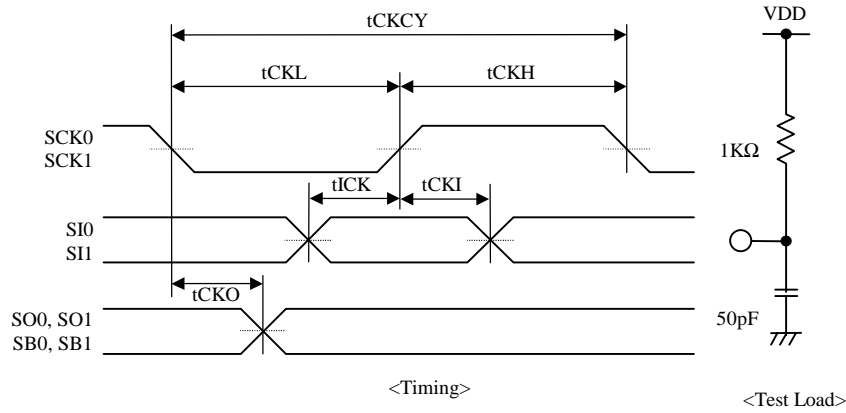
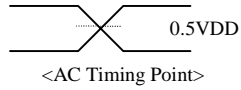

Figure 5 Serial input / output test condition

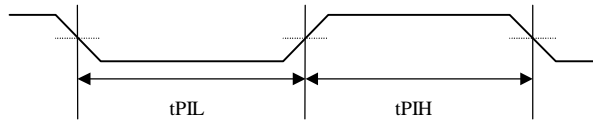

Figure 6 Pulse input timing condition

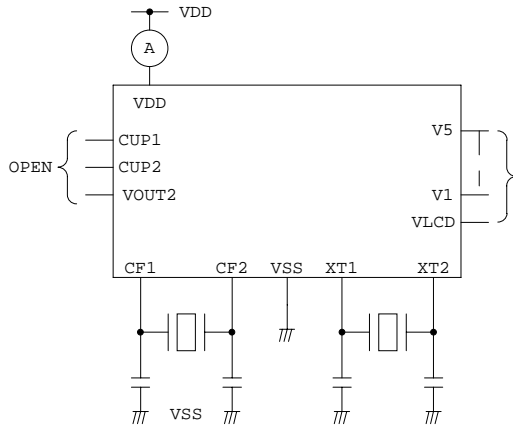

Figure 7 Current dissipation measurement

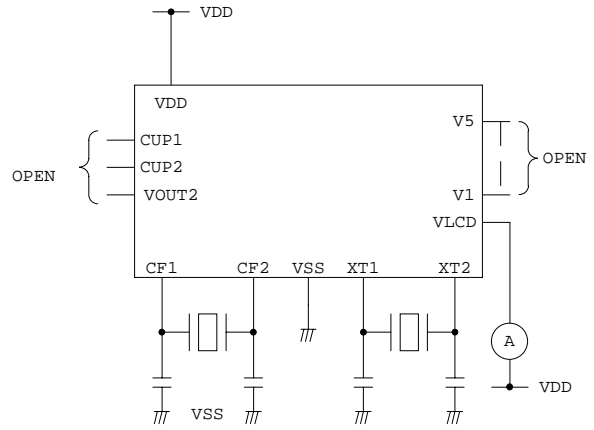

Figure 8 LCD display current measurement

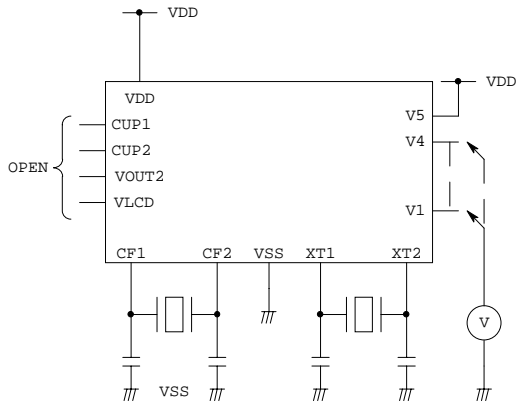

Figure 9 Output voltage of V1-V4 measurement

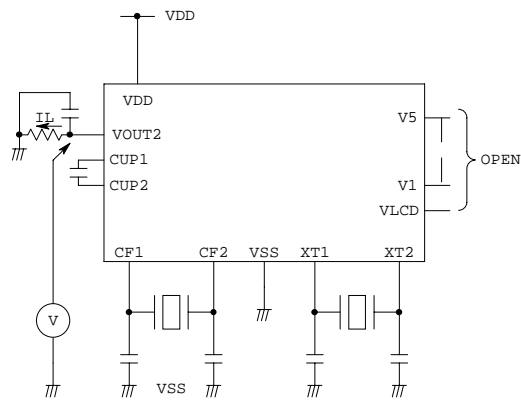

Figure 10 Step up output voltage measurement

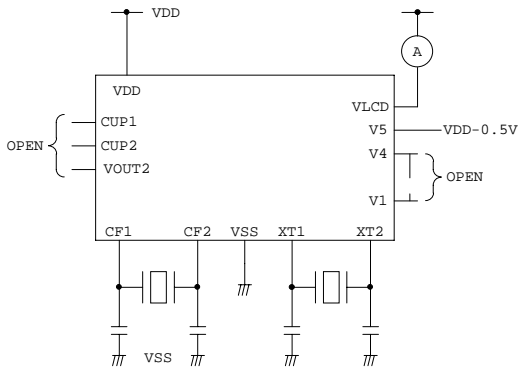

Figure 11 Contrast current measurement



8. AC Characteristics at Ta=-30°C to +70°C, VSS=0V

Load capacity : 100pF (Port 0, ADLC,  $\overline{\text{EROE}}$ )  
 Load capacity : 80pF (Output terminals except above)  
 \*tCLCL=1/12 tCYC

External program memory timing

Parameter	Symbol	Pads and Conditions	Ratings		unit
			VDD[V]	min.	
ADLC pulse width	tLHLL		4.5 - 6.0	2tCLCL-40	ns
			2.5 - 6.0	2tCLCL-160	
Address settling time	tAVLL	For ADLC	4.5 - 6.0	tCLCL-40	
			2.5 - 6.0	tCLCL-160	
Address hold time	tLLAX	For ADLC	4.5 - 6.0	tCLCL-35	
			2.5 - 6.0	tCLCL-140	
ADLC → control signal	tLLEL	For $\overline{\text{EROE}}$	4.5 - 6.0	tCLCL-25	
			2.5 - 6.0	tCLCL-100	
$\overline{\text{EROE}}$ pulse width	tELEH		4.5 - 6.0	3tCLCL-35	
			2.5 - 6.0	3tCLCL-140	
Data delay time	tELIV	From $\overline{\text{EROE}}$	4.5 - 6.0		3tCLCL-125
			2.5 - 6.0		3tCLCL-400
Data hold time	tEHIX	For $\overline{\text{EROE}}$	4.5 - 6.0	0	
			2.5 - 6.0	0	
$\overline{\text{EROE}}$ → address in	tEHAV		4.5 - 6.0	tCLCL-8	
			2.5 - 6.0	tCLCL-32	

Refer to figure 12.

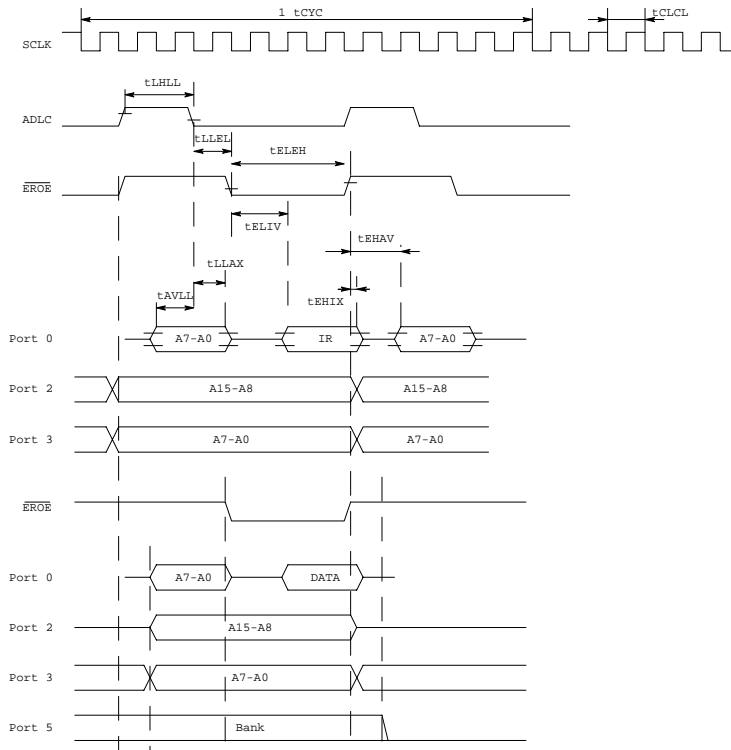

Figure 12 Timing of the external Program Memory/Data Memory

External data memory timing

Parameter	Symbol	Pads and Conditions	Ratings		unit
			VDD[V]	min.	
$\overline{\text{RD}}$ pulse width	tRLRH		4.5 - 6.0	6tCLCL-80	ns
			2.5 - 6.0	6tCLCL-320	
$\overline{\text{WR}}$ pulse width	tWLWH		4.5 - 6.0	6tCLCL-80	
			2.5 - 6.0	6tCLCL-320	
Data address hold time	tLLAX	For ADLC (at LDX)	4.5 - 6.0	2tCLCL-35	
			2.5 - 6.0	2tCLCL-140	
		For ADLC (at STX)	4.5 - 6.0	2tCLCL-35	
			2.5 - 6.0	2tCLCL-140	
Data delay time	tRLDV	From $\overline{\text{RD}}$	4.5 - 6.0		5tCLCL-125
			2.5 - 6.0		5tCLCL-400
Data hold time	tRHDX	From $\overline{\text{RD}}$	4.5 - 6.0	0	
			2.5 - 6.0	0	
Data floating time	tRHDZ	From $\overline{\text{RD}}$	4.5 - 6.0	2tCLCL-70	2tCLCL+70
			2.5 - 6.0	2tCLCL-280	2tCLCL+280
Data address setting time	tAVLL	For ADLC	4.5 - 6.0	tCLCL-40	
			2.5 - 6.0	tCLCL-160	
ADLC $\rightarrow$ control signal	tLLRL	For $\overline{\text{RD}}$	4.5 - 6.0	3tCLCL-50	3tCLCL+50
			2.5 - 6.0	3tCLCL-200	3tCLCL+200
	tLLWL	For $\overline{\text{WR}}$	4.5 - 6.0	3tCLCL-50	3tCLCL+50
			2.5 - 6.0	3tCLCL-200	3tCLCL+200
Data settling time	tQVWL	For $\overline{\text{WR}}$	4.5 - 6.0	tCLCL-60	
			2.5 - 6.0	tCLCL-240	
Data in $\overline{\text{WR}}=1$	tQVWH		4.5 - 6.0	7tCLCL-140	
			2.5 - 6.0	7tCLCL-560	
Data hold time	tWHQX	From $\overline{\text{WR}}$	4.5 - 6.0	tCLCL-50	
			2.5 - 6.0	tCLCL-200	
Control signal $\rightarrow$ ADLC	tRHLH	For $\overline{\text{RD}}$	4.5 - 6.0	tCLCL-50	tCLCL+50
			2.5 - 6.0	tCLCL-200	tCLCL+200
	tWHLH	For $\overline{\text{WR}}$	4.5 - 6.0	tCLCL-50	tCLCL+50
			2.5 - 6.0	tCLCL-200	tCLCL+200

Refer to figure 13.

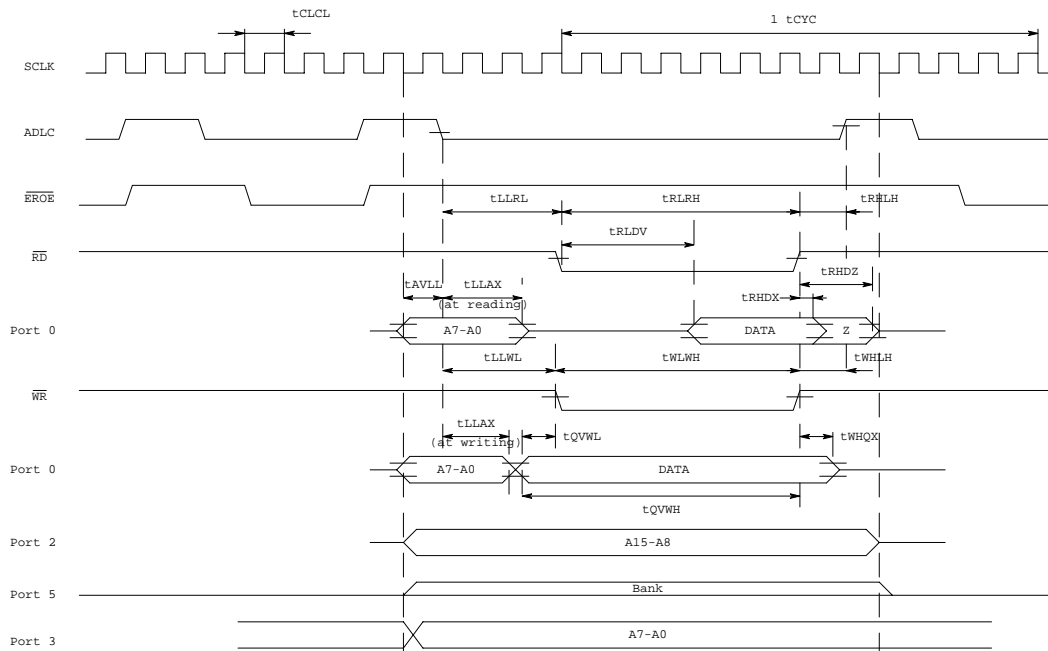

Figure 13 Timing of the external RAM

• Evaluation Sample (ES)

The factory shipment of this microcomputer is chip.  
 But there are two types of shipment of evaluation sample.  
 One type is chip and the other is package (QIC160).

If you selected package type, please refer to the following pin assignment and layout, and make the user target board.

• Pin Assignment of evaluation sample (Package type)

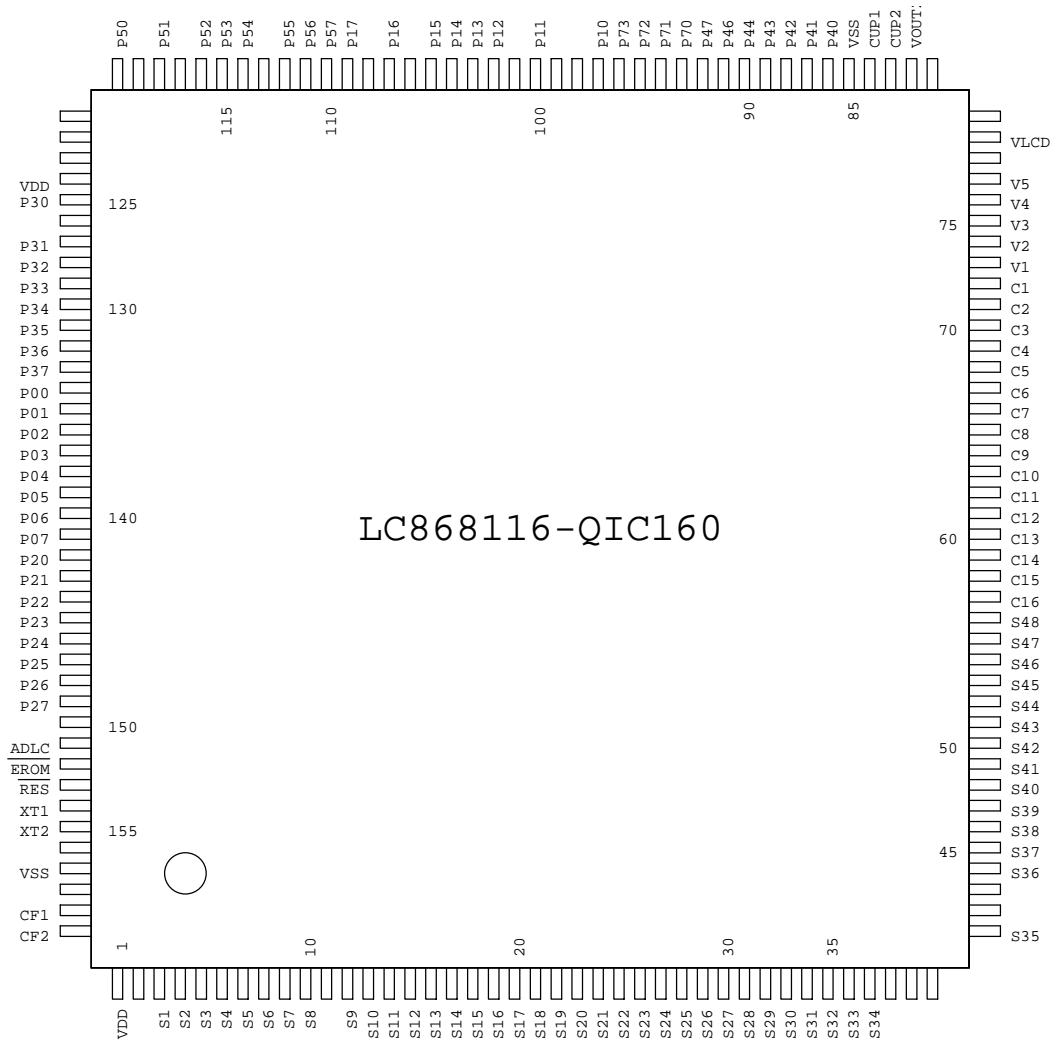

- Layout of evaluation sample (Package type) : QIC160

- Specifications of any and all SANYO products described or contained herein stipulate the performance, characteristics, and functions of the described products in the independent state, and are not guarantees of the performance, characteristics, and functions of the described products as mounted in the customer's products or equipment. To verify symptoms and states that cannot be evaluated in an independent device, the customer should always evaluate and test devices mounted in the customer's products or equipment.
- SANYO Electric Co., Ltd. strives to supply high-quality high-reliability products. However, any and all semiconductor products fail with some probability. It is possible that these probabilistic failures could give rise to accidents or events that could endanger human lives, that could give rise to smoke or fire, or that could cause damage to other property. When designing equipment, adopt safety measures so that these kinds of accidents or events cannot occur. Such measures include but are not limited to protective circuits and error prevention circuits for safe design, redundant design, and structural design.
- In the event that any or all SANYO products (including technical data, services) described or contained herein are controlled under any of applicable local export control laws and regulations, such products must not be exported without obtaining the export license from the authorities concerned in accordance with the above law.
- No part of this publication may be reproduced or transmitted in any form or by any means, electronic or mechanical, including photocopying and recording, or any information storage or retrieval system, or otherwise, without the prior written permission of SANYO Electric Co., Ltd.
- Any and all information described or contained herein are subject to change without notice due to product/technology improvement, etc. When designing equipment, refer to the "Delivery Specification" for the SANYO product that you intend to use.
- Information (including circuit diagrams and circuit parameters) herein is for example only ; it is not guaranteed for volume production. SANYO believes information herein is accurate and reliable, but no guarantees are made or implied regarding its use or any infringements of intellectual property rights or other rights of third parties.

This catalog provides information as of September, 2000. Specifications and information herein are subject to change without notice.