



SANYO Semiconductors

DATA SHEET

LC87F7032A

CMOS IC
FROM 32K byte, RAM 1024 byte on-chip
8-bit 1-chip Microcontroller

Overview

The LC87F7032A is an 8-bit single chip microcontroller with the following on-chip functional blocks:

- CPU: operable at a minimum bus cycle time of 250ns
- 32K bytes Flash ROM
- On-chip PAM: 1024 bytes
- LCD controller/driver
- 16bit timer × 2ch + 8bit timer × 1ch or more
- Synchronous serial I/O port (with automatic block transmit/receive function)
- Asynchronous/synchronous serial I/O port
- System clock divider
- 20-source 10-vectored interrupt system
- 8-bit AD converter × 9-channel
- On chip debugger

All of the above functions are fabricated on a single chip.

Features

■Flash ROM

- Block-erasable in 128byte units
- 32768 × 8 bits (LC87F7032A)

■RAM

- 1024 × 9-bits (LC87F7032A)

* This product is licensed from Silicon Storage Technology, Inc. (USA), and manufactured and sold by SANYO Semiconductor Co., Ltd.

■ Any and all SANYO Semiconductor Co.,Ltd. products described or contained herein are, with regard to "standard application", intended for the use as general electronics equipment (home appliances, AV equipment, communication device, office equipment, industrial equipment etc.). The products mentioned herein shall not be intended for use for any "special application" (medical equipment whose purpose is to sustain life, aerospace instrument, nuclear control device, burning appliances, transportation machine, traffic signal system, safety equipment etc.) that shall require extremely high level of reliability and can directly threaten human lives in case of failure or malfunction of the product or may cause harm to human bodies, nor shall they grant any guarantee thereof. If you should intend to use our products for applications outside the standard applications of our customer who is considering such use and/or outside the scope of our intended standard applications, please consult with us prior to the intended use. If there is no consultation or inquiry before the intended use, our customer shall be solely responsible for the use.

■ Specifications of any and all SANYO Semiconductor Co.,Ltd. products described or contained herein stipulate the performance, characteristics, and functions of the described products in the independent state, and are not guarantees of the performance, characteristics, and functions of the described products as mounted in the customer's products or equipment. To verify symptoms and states that cannot be evaluated in an independent device, the customer should always evaluate and test devices mounted in the customer's products or equipment.

SANYO Semiconductor Co., Ltd.

TOKYO OFFICE Tokyo Bldg., 1-10, 1 Chome, Ueno, Taito-ku, TOKYO, 110-8534 JAPAN

■ Minimum Bus Cycle Time

- 250ns (4MHz)

Note: Bus cycle time indicates the speed to read ROM.

■ Minimum Instruction Cycle Time (tCYC)

- 750ns (4MHz)

■ Ports

- Input/output ports

Data direction programmable for each bit individually 12 (P1n, P70 to P73)

Data direction programmable in nibble units 8 (P0n)

(When N-channel open drain output is selected, data can be input in bit units.)

Other function 3 (DBGP0, DBGP1, DBGP2)

- PWM input/output port1 (PWM)

- LCD ports

Segment output 24 (S00 to S23)

Common output 4 (COM0 to COM3)

Bias terminals for LCD driver 5 (V1 to V3, CUP1, CUP2)

Other functions

Input/output ports 8 (PCn)

- Oscillator pins 4 (CF1, CF2, XT1, XT2)

- Reset pin 1 (RES)

- Power supply 4 (V_{SS}1 to 2, V_{DD}1 to 2)

1 (VDC)

■ LCD Controller

- Seven display modes are available
- Duty 1/3duty, 1/4duty
- Bias 1/2bias, 1/3bias
- Segment output can be switched to general purpose input/output ports.

■ Timers

- Timer 0: 16-bit timer/counter with capture register

Mode 0: 2 channel 8-bit timer with programmable 8 bit prescaler and 8 bit capture register

Mode 1: 8 bit timer with 8 bit programmable prescaler and 8 bit capture register + 8 bit counter with 8-bit capture register

Mode 2: 16 bit timer with 8 bit programmable prescaler and 16 bit capture register

Mode 3: 16 bit counter with 16 bit capture register

- Timer1: PWM/16 bit timer/counter with toggle output function

Mode 0: 2 channel 8 bit timer/counter (with toggle output)

Mode 1: 2 channel 8 bit PWM

Mode 2: 16 bit timer/counter (with toggle output) toggle output from lower 8 bits is also possible.

Mode 3: 16 bit timer (with toggle output) lower order 8 bits can be used as PWM.

- Timer4: 8-bit timer with 6-bit prescaler

- Timer5: 8-bit timer with 6-bit prescaler

- Timer6: 8-bit timer with 6-bit prescaler (with toggle output)

- Timer7: 8-bit timer with 6-bit prescaler (with toggle output)

- Base Timer

1) The clock signal can be selected from any of the following:

Sub-clock (32.768kHz crystal oscillator), system clock, and prescaler output from timer 0

2) Interrupts of five different time intervals are possible.

LC87F7032A

■SIO

- SIO0: 8-bit synchronous serial interface
 - 1) LSB first/MSB first is selectable
 - 2) Internal 8 bit baud-rate generator (fastest clock period $4/3 t_{CYC}$)
 - 3) Consecutive automatic data communication (1 to 256 bits)
- SIO1: 8 bit asynchronous/synchronous serial interface
 - Mode 0: Synchronous 8 bit serial IO (2-wire or 3-wire, transmit clock 2 to 512 tCYC)
 - Mode 1: Asynchronous serial IO (half duplex, 8 data bits, 1 stop bit, baud rate 8 to 2048 tCYC)
 - Mode 2: Bus mode 1 (start bit, 8 data bits, transmit clock 2 to 512 tCYC)
 - Mode 3: Bus mode 2 (start detection, 8 data bits, stop detection)

■UART

- Full duplex
- 1 stop bit (2-bit in continuous data transmission)
- Built-in baudrate generator

■AD Converter

- 8-bit \times 9-channels

■PWM

- Multifrequency 12-bit PWM \times 1-channels

■Remote Control Receiver Circuit (sharing pins with P73, INT3, and T0IN)

- Noise rejection function (noise rejection filter's time constant can be selected from $1/32/128 t_{CYC}$)

■Watchdog Timer

- Watchdog timer can produce interrupt or system reset.
- Watchdog timer has two types.
 - Use an external RC circuit
 - Use the microcontroller's basetimer

■Clock Output Function

- 1) Able to output selected oscillation clock $1/1, 1/2, 1/4, 1/8, 1/16, 1/32, 1/64$ as system clock.
- 2) Able to output oscillation clock of sub clock.

■Interrupts

- 20 sources, 10 vector addresses
 - 1) Three priority (low, high and highest) multiple interrupts are supported. During interrupt handling, an equal or lower priority interrupt request is postponed.
 - 2) If interrupt requests to two or more vector addresses occur at once, the higher priority interrupt takes precedence. In the case of equal priority levels, the vector with the lowest address takes precedence.

No.	Vector Address	Level	Interrupt Source
1	00003H	X or L	INT0
2	0000BH	X or L	INT1
3	00013H	H or L	INT2/T0L
4	0001BH	H or L	INT3/base timer
5	00023H	H or L	T0H
6	0002BH	H or L	T1L/T1H
7	00033H	H or L	SIO0/UART1 receive
8	0003BH	H or L	SIO1/UART-send
9	00043H	H or L	ADC/T6/T7
10	0004BH	H or L	Port 0/T4/T5/PWM

- Priority levels $X > H > L$
- For equal priority levels, vector with lowest address takes precedence.

■Subroutine Stack Levels

- 512 levels maximum (the stack is allocated in RAM)

■High-speed Multiplication/Division Instructions

- 16-bits × 8-bits (5 tCYC execution time)
- 24-bits × 16-bits (12 tCYC execution time)
- 16-bits ÷ 8-bits (8 tCYC execution time)
- 24-bits ÷ 16-bits (12 tCYC execution time)

■Oscillation Circuits

- On-chip RC oscillation for system clock use.
- CF oscillation (4MHz) for system clock use. (Rf built in, Rd external)
- Crystal oscillation (32.768kHz) low speed system clock use. (Rf built in, Rd external)
- On-chip frequency variable RC oscillation circuit for system clock use.

■System Clock Divider Function

- Low power consumption operation is available
- Minimum instruction cycle time (750ns, 1.5μs, 3.0μs, 6.0μs, 12μs, 24μs, 48μs, 96μs, 192μs can be switched by program (when using 4MHz main clock)

■Standby Function

- HALT mode:

HALT mode is used to reduce power consumption. During the HALT mode, program execution is stopped but peripheral circuits keep operating (some parts of serial transfer operation stop.)

- 1) Oscillation circuits are not stopped automatically.
- 2) Released by the system reset or interrupts.

- HOLD mode

HOLD mode is used to reduce power consumption. Program execution and peripheral circuits are stopped.

- 1) CF, RC and crystal oscillation circuits stop automatically.
- 2) Released by any of the following conditions.
 - (1) Low level input to the reset pin
 - (2) Specified level input to one of INT0, INT1, INT2.
 - (3) Port 0 interrupt

- X'tal HOLD mode

X'tal HOLD mode is used to reduce power consumption. Program execution is stopped.

All peripheral circuits except the base timer are stopped.

- 1) CF and RC oscillation circuits stop automatically.
- 2) Crystal oscillator operation is kept in its state at HOLD mode inception.
- 3) Released by any of the following conditions
 - (1) Low level input to the reset pin
 - (2) Specified level input to one of INT0, INT1, INT2.
 - (3) Port 0 interrupt
 - (4) Base-timer interrupt

■ROM Correct Function

- ROM correct program is executed by checking the program counter.
- ROM correct program area: 128byte

■On-chip Debugger Function

- Software debug is available on the target board.

■Package Form

- TQFP64J(7×7) :Lead-free type
- QIP64E(14×14) :Lead-free type

■Development Tool

- On-chip Debugger: TCB87 TypeB+LC87F7032A

LC87F7032A

Flash ROM Programming boards

Package	Programming Boards
TQFP64J(7×7)	W87F70256TQ7
QIP64E(14×14)	W87F70256Q

Package Dimensions

unit : mm (typ)

3289

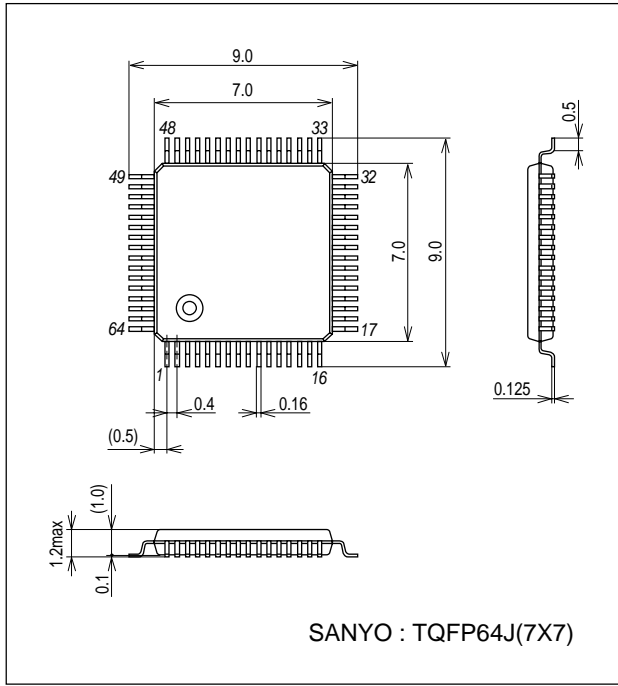

Package Dimensions

unit : mm (typ)

3159A

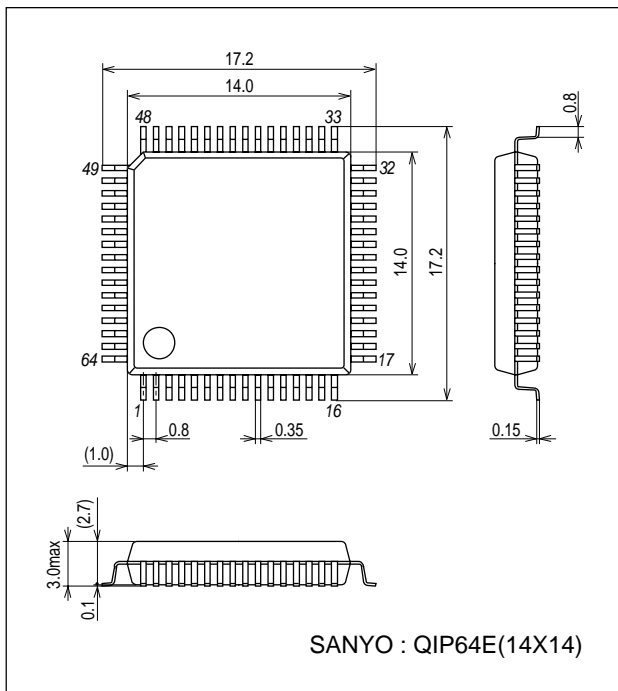

LC87F7032A

Pin Assignment

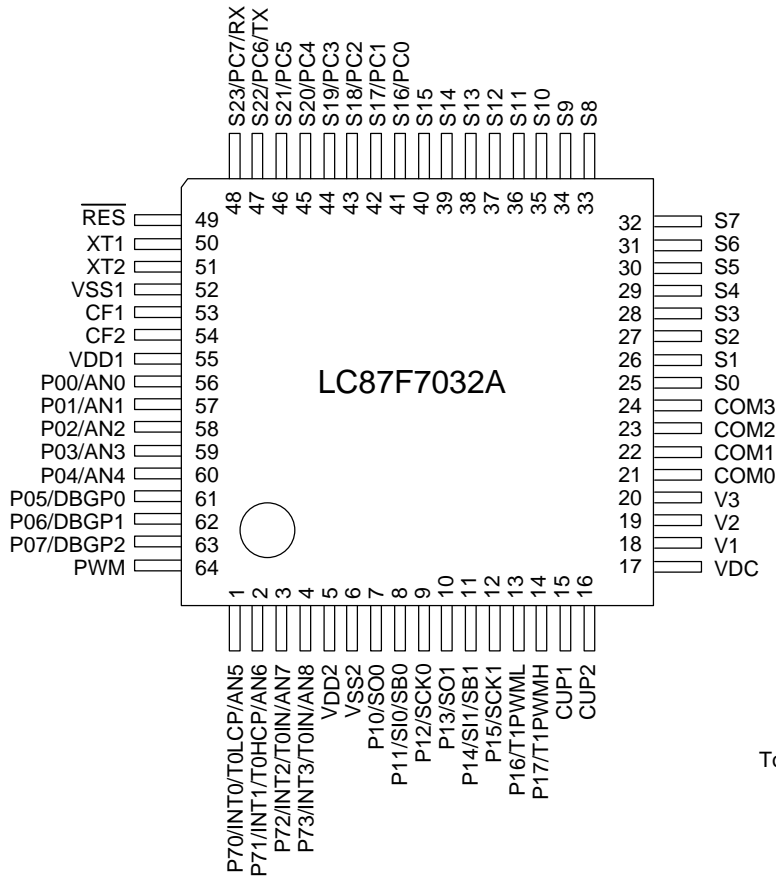

SANYO: TQFP64J(7×7)

“Lead-free Type”

SANYO: QIP64E(14×14)

“Lead-free Type”

System Block Diagram

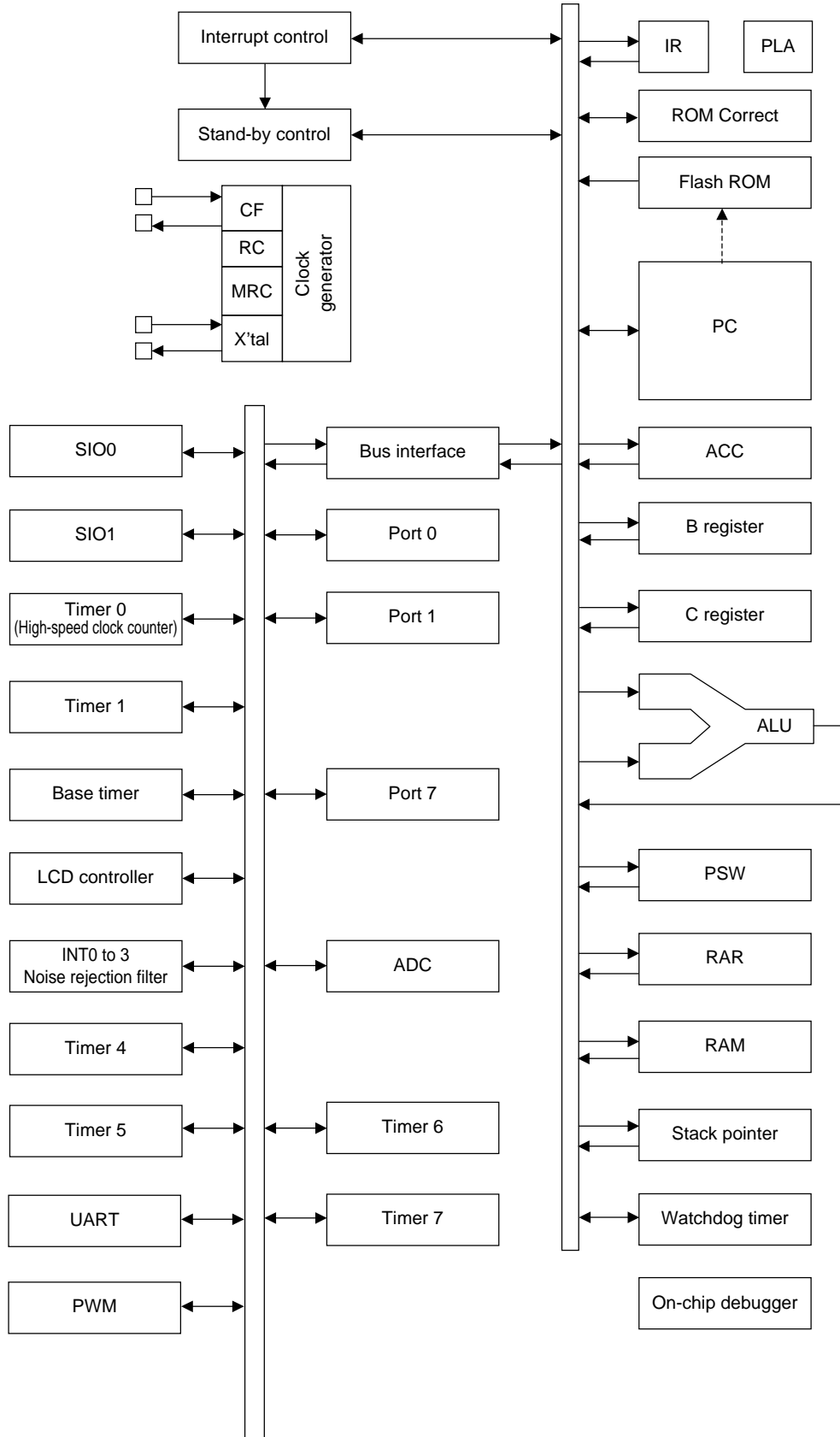

LC87F7032A

Pin Description

Pin name	I/O	Function	Option																														
V _{SS1} ,V _{SS2}	-	• Power supply (-)	No																														
V _{DD1} ,V _{DD2}	-	• Power supply (+)	No																														
VDC	-	• Power supply (+)	No																														
CUP1,CUP2	-	• Capacitor connecting terminals for step-up/step-down	No																														
PWM	I/O	• PWM input/output port	No																														
PORT0 P00 to P07	I/O	<ul style="list-style-type: none"> • 8bit input/output port • Data direction programmable in nibble units • Use of pull-up resistor can be specified in nibble units • Input for HOLD release • Input for port 0 interrupt • Input for AD Converter: AN0(P00) to AN4(P04) • On chip debugger terminal (P05, P06, P07) 	Yes																														
PORT1 P10 to P17	I/O	<ul style="list-style-type: none"> • 8bit input/output port • Data direction programmable for each bit • Use of pull-up resistor can be specified for each bit individually • Other pin functions <ul style="list-style-type: none"> P10 SIO0 data output P11 SIO0 data input or bus input/output P12 SIO0 clock input/output P13 SIO1 data output P14 SIO1 data input or bus input/output P15 SIO1 clock input/output P16: Timer 1 PWML output P17: Timer 1 PWMH output/buzzer output 	Yes																														
PORT7 P70 to P73	I/O	<ul style="list-style-type: none"> • 4bit Input/output port • Data direction can be specified for each bit • Use of pull-up resistor can be specified for each bit individually • Input for AD Converter (AN5 to AN8) • Other functions <ul style="list-style-type: none"> P70: INT0 input/HOLD release input/timer0L capture input/output for watchdog timer/AN5 P71: INT1 input/HOLD release input/timer0H capture input/AN6 P72: INT2 input/HOLD release input/timer 0 event input/timer0L capture input/AN7 P73: INT3 input (noise rejection filter attached)/timer 0 event input/timer0H capture input/AN8 • Interrupt detection selection <table border="1" style="margin-left: 20px;"> <thead> <tr> <th></th> <th>Rising</th> <th>Falling</th> <th>Rising and falling</th> <th>H level</th> <th>L level</th> </tr> </thead> <tbody> <tr> <td>INT0</td> <td>enable</td> <td>enable</td> <td>disable</td> <td>enable</td> <td>enable</td> </tr> <tr> <td>INT1</td> <td>enable</td> <td>enable</td> <td>disable</td> <td>enable</td> <td>enable</td> </tr> <tr> <td>INT2</td> <td>enable</td> <td>enable</td> <td>enable</td> <td>disable</td> <td>disable</td> </tr> <tr> <td>INT3</td> <td>enable</td> <td>enable</td> <td>enable</td> <td>disable</td> <td>disable</td> </tr> </tbody> </table> 		Rising	Falling	Rising and falling	H level	L level	INT0	enable	enable	disable	enable	enable	INT1	enable	enable	disable	enable	enable	INT2	enable	enable	enable	disable	disable	INT3	enable	enable	enable	disable	disable	No
	Rising	Falling	Rising and falling	H level	L level																												
INT0	enable	enable	disable	enable	enable																												
INT1	enable	enable	disable	enable	enable																												
INT2	enable	enable	enable	disable	disable																												
INT3	enable	enable	enable	disable	disable																												
S0 to S15	O	• Segment output for LCD	No																														
S16/PC0 to S23/PC7	I/O	<ul style="list-style-type: none"> • Segment output for LCD • Can be used as general purpose input/output port (PC) • UART terminal (S22, S23) 	No																														
COM0 to COM3	O	• Common output for LCD	No																														
V1 to V3	I/O	• LCD output bias power supply	No																														
$\overline{\text{RES}}$	I	• Reset terminal	No																														
XT1	I	<ul style="list-style-type: none"> • Input for 32.768kHz crystal oscillation • When not in use, connect to V_{DD1} 	No																														
XT2	I/O	<ul style="list-style-type: none"> • Output for 32.768kHz crystal oscillation • When not in use, set to oscillation mode and leave open 	No																														
CF1	I	<ul style="list-style-type: none"> • Input terminal for ceramic oscillator • When not in use, connect to V_{DD1} 	No																														
CF2	O	<ul style="list-style-type: none"> • Output terminal for ceramic oscillator • When not in use, leave open 	No																														

LC87F7032A

Port Output Configuration

Port form and pull-up resistor options are shown in the following table.

Port status can be read even when port is set to output mode.

Terminal	Option applies to:	Options	Output Form	Pull-up resistor
P00 to P07	each bit	1	CMOS	Programmable (Note 1)
		2	Nch-open drain	None
P10 to P17	each bit	1	CMOS	Programmable
		2	Nch-open drain	Programmable
P70	-	None	Nch-open drain	Programmable
P71 to P73	-	None	CMOS	Programmable
S16(PC0) to S23(PC7)	each bit	1	CMOS	None
		2	P-ch Open Drain	
		3	N-ch Open Drain	

Note 1: Attachment of Port0 programmable pull-up resistors is controllable in nibble units (P00 to 03, P04 to 07).

* 1: Connect as follows to reduce noise on VDD.

VSS1 and VSS2 must be connected together and grounded.

* 2: The power supply for the internal memory is VDD1. VDD1 and VDD2 are used as the power supply for ports.

When VDD1 and VDD2 are not backed up, the port level does not become “H” even if the port latch is in the “H” level. Therefore, when VDD1 and VDD2 are not backed up and the port latch is “H” level, the port level is unstable in the HOLD mode, and the back up time becomes shorter because the through current runs from VDD to GND in the input buffer.

If VDD1 and VDD2 are not backed up, output “L” by the program or pull the port to “L” by the external circuit in the HOLD mode so that the port level becomes “L” level and unnecessary current consumption is prevented.

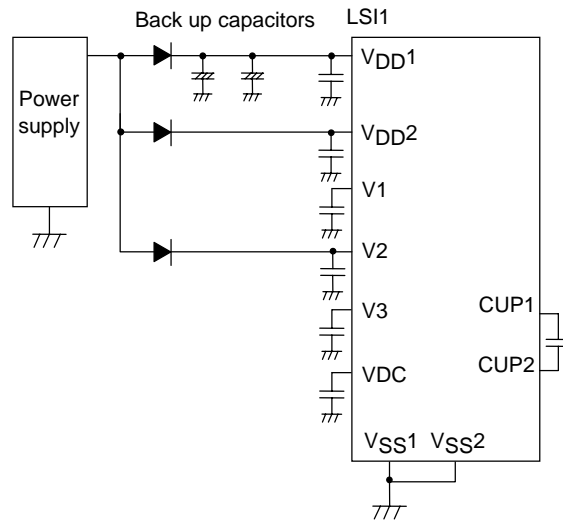

LC87F7032A

Absolute Maximum Ratings at Ta = 25°C, VSS1 = VSS2 = 0V

Parameter	Symbol	Pins	Conditions	Specification				unit
				VDD[V]	min	typ	max	
Supply voltage	VDD max	VDD1,VDD2,V2	VDD1=VDD2=V2		-0.3		+4.6	V
Supply voltage For LCD	VLCD	V1			-0.3		1/2 VDD	
		V2			-0.3		VDD	
		V3			-0.3		3/2 VDD	
Input voltage	VI	XT1,CF1,RES			-0.3		VDD+0.3	
Input/Output voltage	VI/O(1)	<ul style="list-style-type: none"> • Ports 0, 1, 7 • Port C, PWM 			-0.3		VDD+0.3	
High level output current	Peak output current	IOPH(1)	Ports 0, 1, 7, C, PWM	<ul style="list-style-type: none"> • CMOS output selected • Current at each pin 		-4		mA
	Total output current	ΣIOAH(1)	Port 7, PWM	Total of all pins		-10		
		ΣIOAH(2)	Port 0	Total of all pins		-25		
		ΣIOAH(3)	Port 1	Total of all pins		-25		
ΣIOAH(4)		Port C	Total of all pins		-15			
Low level output current	Peak output current	IOPL(1)	Ports 02 to 07 Ports 1, 7, C, PWM	Current at each pin			6	
		IOPL(2)	Ports 00, 01	Current at each pin			15	
	Total output current	ΣIOAL(1)	Port 7, PWM	Total of all pins			10	
		ΣIOAL(2)	Port 0	Total of all pins			35	
		ΣIOAL(3)	Port 1	Total of all pins			25	
ΣIOAL(4)	Port C	Total of all pins			15			
Allowable power dissipation	Pd max	TQFP64J(7×7)	Ta=-20 to +70°C				185	mW
		QIP64E(14 ×14)					410	
Operating ambient temperature	Topr				-20		+70	°C
Storage ambient temperature	Tstg				-55		+125	

LC87F7032A

Recommended Operating Range at $T_a = -20^{\circ}\text{C}$ to $+70^{\circ}\text{C}$, $V_{SS1} = V_{SS2} = 0\text{V}$

Parameter	Symbol	Pins	Conditions	Specification				unit
				$V_{DD}[\text{V}]$	min	typ	max	
Operating supply voltage range	$V_{DD(1)}$	$V_{DD1}=V_{DD2}=V_2$	$0.75\mu\text{s}\leq t_{CYC}\leq 200\mu\text{s}$	2.4 to 3.6	3.0		3.6	V
	$V_{DD(2)}$		$0.75\mu\text{s}\leq t_{CYC}\leq 200\mu\text{s}$ expect on-board write		2.4		3.6	
Supply voltage range in hold mode	VHD	V_{DD1}	Keep RAM and register data in HOLD mode.		2.2		3.6	
Input high voltage	$V_{IH(1)}$	• Ports 1, 71 to 73 • Port 70 input/interrupt	Output disable	2.4 to 3.6	$0.3V_{DD}$ $+0.7$		V_{DD}	
	$V_{IH(2)}$	• Ports 0, C • PWM	Output disable	2.4 to 3.6	$0.3V_{DD}$ $+0.7$		V_{DD}	
	$V_{IH(3)}$	Port 70 Watchdog timer	Output disable	2.4 to 3.6	$0.9V_{DD}$		V_{DD}	
	$V_{IH(4)}$	XT1, CF1, $\overline{\text{RES}}$		2.4 to 3.6	$0.75V_{DD}$		V_{DD}	
Input low Voltage	$V_{IL(1)}$	• Ports 1, 71 to 73 • Port 70 input/interrupt	Output disable	2.4 to 3.6	V_{SS}		$0.2V_{DD}$	
	$V_{IL(2)}$	• Ports 0, C • PWM	Output disable	2.4 to 3.6	V_{SS}		$0.2V_{DD}$	
	$V_{IL(3)}$	Port 70 Watchdog timer	Output disable	2.4 to 3.6	V_{SS}		$0.8V_{DD}$ -1.0	
	$V_{IL(4)}$	XT1, CF1, $\overline{\text{RES}}$		2.4 to 3.6	V_{SS}		$0.25V_{DD}$	
Operation cycle time	t_{CYC}			2.4 to 3.6	0.75		200	μs
External system clock frequency	FEXCF(1)	CF1	• CF2 open	2.4 to 3.6	0.1		4	MHz
			• system clock divider: 1/1	2.4 to 3.6	0.1		8	
• external clock DUTY=50±5%								
Oscillation frequency range (Note2-1)	FmCF	CF1, CF2	4MHz ceramic resonator oscillation See Fig. 1.	2.4 to 3.6		4		
	FmRC		RC oscillation target: $V_{DD}=3.00\text{V}$, $T_a=25^{\circ}\text{C}$	2.4 to 3.6	0.3	0.5	0.7	
	FsX'tal	XT1, XT2	32.768kHz crystal resonator oscillation See Fig. 2.	2.4 to 3.6		32.768		KHz

Note 2-1: The parts value of oscillation circuit is shown in table 1 and table 2.

LC87F7032A

Electrical Characteristics at Ta = -20°C to +70°C, VSS1 = VSS2 = 0V

Parameter	Symbol	Pins	Conditions	Specification				
				VDD[V]	min	typ	max	unit
High level input current	I _{IH} (1)	• Ports 0, 1, 7 • Port C, PWM • $\overline{\text{RES}}$	• Output disabled • Pull-up resistor OFF. • V _{IN} =V _{DD} (Including OFF state leak current of the output Tr.)	2.4 to 3.6			1	μA
	I _{IH} (2)	XT1, XT2	When configured as an input port V _{IN} =V _{DD}	2.4 to 3.6			1	
	I _{IH} (3)	CF1	V _{IN} =V _{DD}	2.4 to 3.6			8	
Low level input current	I _{IL} (1)	• Ports 0, 1, 7 • Port C, PWM • $\overline{\text{RES}}$	• Output disabled • Pull-up resistor OFF. • V _{IN} =V _{SS} (Including OFF state leak current of the output Tr.)	2.4 to 3.6	-1			μA
	I _{IL} (2)	XT1, XT2	When configured as an input port V _{IN} =V _{SS}	2.4 to 3.6	-1			
	I _{IL} (3)	CF1	V _{IN} =V _{SS}	2.4 to 3.6	-8			
High level output voltage	V _{OH} (1)	Ports 0, 1, 7 CMOS output option	I _{OH} =-0.4mA	3.0 to 3.6	V _{DD} -0.4			V
	V _{OH} (2)		I _{OH} =-0.2mA	2.4 to 3.6	V _{DD} -0.4			
	V _{OH} (3)	Port C	I _{OH} =-0.1mA	2.4 to 3.6	V _{DD} -0.4			
	V _{OH} (4)	PWM	I _{OH} =-1.6mA	3.0 to 3.6	V _{DD} -0.4			
			I _{OH} =-0.8mA	2.4 to 3.6	V _{DD} -0.4			
Low level output voltage	V _{OL} (1)	Ports 0, 1, 7, PWM	I _{OL} =1.6mA	3.0 to 3.6			0.4	V
	V _{OL} (2)		I _{OL} =0.8mA	2.4 to 3.6			0.4	
	V _{OL} (3)	P00, P01	I _{OL} =5.0mA	3.0 to 3.6			0.4	
	V _{OL} (4)		I _{OL} =2.5mA	2.4 to 3.6			0.4	
	V _{OL} (5)	Port C	I _{OL} =0.1mA	2.4 to 3.6			0.4	
LCD output voltage regulation	VODLS	S0 to S23	I _O =0mA V1, V2, V3 LCD level output	2.4 to 3.6	0		±0.2	V
	VODLC	COM0 to COM3	I _O =0mA V1, V2, V3 LCD level output	2.4 to 3.6	0		±0.2	
Resistance of pull-up MOS Tr.	R _{pu}	• Ports 0, 1, 7	V _{OH} =0.9V _{DD}	2.4 to 3.6	25	50	200	kΩ
Hysteresis voltage	V _{HYS} (1)	• Ports 1, 7 • $\overline{\text{RES}}$		2.4 to 3.6		0.1V _{DD}		V
Pin capacitance	CP	All pins	• All other terminals connected to V _{SS} . • f=1MHz • Ta=25°C	2.4 to 3.6		10		pF

LC87F7032A

Serial I/O Characteristics at Ta = -20°C to +70°C, V_{SS1} = V_{SS2} = 0V

1. SIO0 Serial I/O Characteristics (Note 4-1-1)

Parameter		Symbol	Pin/Remarks	Conditions	V _{DD}	Specification					
						min	typ	max	unit		
Serial clock	Input clock	Frequency	tSCK(1)	SCK0(P12)	See Fig. 6.	2.4 to 3.6	2			tCYC	
		Low level pulse width	tSCKL(1)				1				
		High level pulse width	tSCKH(1)				1				
			tSCKHA(1)						4		
	Output clock	Frequency	tSCK(2)	SCK0(P12)	<ul style="list-style-type: none"> • CMOS output selected • See Fig. 6. 	2.4 to 3.6	4/3			tSCK	
		Low level pulse width	tSCKL(2)				1/2				
High level pulse width		tSCKH(2)	1/2								
		tSCKHA(2)						tSCKH(2) +(10/3) tCYC	tCYC		
Serial input	Data setup time	tsDI(1)	SB0(P11), SIO(P11)	<ul style="list-style-type: none"> • Must be specified with respect to rising edge of SIOCLK. • See Fig. 6. 	2.4 to 3.6	0.03					
	Data hold time	thDI(1)				2.4 to 3.6	0.03				
Serial output	Input clock	Output delay time	tdD0(1)	SO0(P10), SB0(P11)	<ul style="list-style-type: none"> • Continuous data transmission/reception mode (Note 4-1-3) 	2.4 to 3.6			(1/3)tCYC +0.05	μs	
			tdD0(2)				<ul style="list-style-type: none"> • Synchronous 8-bit mode (Note 4-1-3) 	2.4 to 3.6			
	tdD0(3)		(Note 4-1-3)				2.4 to 3.6				(1/3)tCYC +0.05

Note 4-1-1: These specifications are theoretical values. Add margin depending on its use.

Note 4-1-2: To use serial-clock-input in continuous trans/rec mode, a time from SIORUN being set when serial clock is "H" to the first negative edge of the serial clock must be longer than tSCKHA.

Note 4-1-3: Must be specified with respect to falling edge of SIOCLK. Must be specified as the time to the beginning of output state change in open drain output mode. See Fig. 6.

LC87F7032A

2. SIO1 Serial I/O Characteristics (Note 4-2-1)

Parameter		Symbol	Pin/Remarks	Conditions	Specification					
					V _{DD}	min	typ	max	unit	
Serial clock	Input clock	Frequency	tSCK(3)	SCK1(P15)	See Fig. 6.	2.4 to 3.6	2			tCYC
		Low level pulse width	tSCKL(3)				1			
		High level pulse width	tSCKH(3)				1			
	Output clock	Frequency	tSCK(4)	SCK1(P15)	<ul style="list-style-type: none"> • CMOS output selected • See Fig. 6. 	2.4 to 3.6	2			tSCK
		Low level pulse width	tSCKL(4)				1/2			
		High level pulse width	tSCKH(4)				1/2			
Serial input	Data setup time	tsDI(2)	SB1(P14), S11(P14)	<ul style="list-style-type: none"> • Must be specified with respect to rising edge of SIOCLK. • See Fig. 6. 	2.4 to 3.6	0.03			μs	
	Data hold time	thDI(2)				2.4 to 3.6	0.03			
Serial output	Output delay time	tdD0(4)	SO1(P13), SB1(P14)	<ul style="list-style-type: none"> • Must be specified with respect to falling edge of SIOCLK. • Must be specified as the time to the beginning of output state change in open drain output mode. • See Fig. 6. 	2.4 to 3.6			(1/3)tCYC +0.05	μs	

Note 4-2-1: These specifications are theoretical values. Add margin depending on its use.

Pulse Input Conditions at Ta = -20°C to +70°C, V_{SS1} = V_{SS2} = 0V

Parameter	Symbol	Pins	Conditions	Specification				
				V _{DD} [V]	min	typ	max	unit
High/low level pulse width	tPIH(1) tPIL(1)	INT0(P70), INT1(P71), INT2(P72)	<ul style="list-style-type: none"> • Condition that interrupt is accepted • Condition that event input to timer 0 is accepted 	2.4 to 3.6	1			tCYC
	tPIH(2) tPIL(2)	INT3(P73) (Noise rejection ratio is 1/1.)	<ul style="list-style-type: none"> • Condition that interrupt is accepted • Condition that event input to timer 0 is accepted 	2.4 to 3.6	2			
	tPIH(3) tPIL(3)	INT3(P73) (Noise rejection ratio is 1/32.)	<ul style="list-style-type: none"> • Condition that interrupt is accepted • Condition that event input to timer 0 is accepted 	2.4 to 3.6	64			
	tPIH(4) tPIL(4)	INT3(P73) (Noise rejection ratio is 1/128.)	<ul style="list-style-type: none"> • Condition that interrupt is accepted • Condition that event input to timer 0 is accepted 	2.4 to 3.6	256			
	tPIL(6)	RES		• Condition that reset is accepted	2.4 to 3.6	200		

LC87F7032A

AD Converter Characteristics at Ta = -20°C to +70°C, VSS1 = VSS2 = 0V

Parameter	Symbol	Pin/Remarks	Conditions	Specification				
				V _{DD} [V]	min.	typ.	max.	unit
Resolution	N	AN0(P00) to AN4(P04), AN5(P70) to AN8(P73)			8		bit	
Absolute accuracy	ET		(Note 6-1)			±1.5	LSB	
Conversion time	tCAD		AD conversion time=32×tCYC (When ADCR2=0) (Note 6-2)		24 (tCYC= 0.75μs)		320 (tCYC= 10μs)	μs
			AD conversion time 64×tCYC (When ADCR2=1) (Note 6-2)		48 (tCYC= 0.75μs)		640 (tCYC= 10μs)	
Analog input voltage range	VAIN				V _{SS}		V _{DD}	V
Analog port input current	I _{AINH}			V _{AIN} =V _{DD}			1	μA
	I _{AINL}		V _{AIN} =V _{SS}		-1			

Note 6-1: The quantization error ($\pm 1/2$ LSB) is excluded from the absolute accuracy value.

Note 6-2: The conversion time refers to the interval from the time the instruction for starting the converter is issued till the complete digital value corresponding to the analog input value is loaded in the required register.

Consumption Current Characteristics at Ta = -20°C to +70°C, VSS1 = VSS2 = 0V

Parameter	Symbol	Pins	Conditions	Specification				
				V _{DD} [V]	min	typ	max	unit
Normal mode consumption current (Note 7-1)	IDDOP(1)	V _{DD1} = V _{DD2} = V2	<ul style="list-style-type: none"> FmCF=4MHz ceramic resonator oscillation FmX'tal=32.768kHz crystal oscillation System clock: CF 4MHz oscillation Internal RC oscillation stopped. Divider: 1/1 	2.4 to 3.6		1.7	4.2	mA
	IDDOP(2)		<ul style="list-style-type: none"> FmCF=1MHz ceramic resonator oscillation FmX'tal=32.768kHz crystal oscillation System clock: CF 1MHz oscillation Internal RC oscillation stopped. Divider: 1/1 	2.4 to 3.6		0.6	1.4	
	IDDOP(3)		<ul style="list-style-type: none"> FmCF=0Hz (No oscillation) FmX'tal=32.768kHz crystal oscillation System clock: RC oscillation Divider: 1/1 	2.4 to 3.6		0.4	0.9	
	IDDOP(4)		<ul style="list-style-type: none"> FmCF=0Hz (No oscillation) FmX'tal=32.768kHz crystal oscillation System clock: RC oscillation Divider: 1/2 	2.4 to 3.6		0.3	0.6	
	IDDOP(5)		<ul style="list-style-type: none"> FmCF=0Hz (No oscillation) FmX'tal=32.768kHz crystal oscillation System clock: variable RC oscillation 1MHz Divider: 1/1 	2.4 to 3.6		20	59	μA
	IDDOP(6)		<ul style="list-style-type: none"> FmCF=0Hz (No oscillation) FmX'tal=32.768kHz crystal oscillation System clock: 32.768kHz Internal RC oscillation stopped. Divider: 1/2 	2.4 to 3.6		15	45	

Note 7-1: The currents through the output transistors and the pull-up MOS transistors are ignored.

Continued on next page.

LC87F7032A

Continued from preceding page.

Parameter	Symbol	Pins	Conditions	Specification				
				V _{DD} [V]	min	typ	max	unit
HALT mode consumption current (Note 7-1)	IDDHALT(1)	V _{DD1} = V _{DD2} =V2	HALT mode • FmCF=4MHz Ceramic resonator oscillation • FmX'tal=32.768kHz crystal oscillation • System clock: CF 4MHz oscillation • Internal RC oscillation stopped. • Divider: 1/1	2.4 to 3.6		0.8	2.1	mA
	IDDHALT(2)		HALT mode • FmCF=1MHz Ceramic resonator oscillation • FmX'tal=32.768kHz crystal oscillation • System clock:CF 1MHz oscillation • Internal RC oscillation stopped. • Divider: 1/1	2.4 to 3.6		0.3	1.4	
	IDDHALT(3)		HALT mode • FmCF=0Hz(Oscillation stop) • FmX'tal=32.768kHz crystal oscillation • System clock: RC oscillation • Divider: 1/1	2.4 to 3.6		0.20	0.5	
	IDDHALT(4)		HALT mode • FmCF=0Hz(Oscillation stop) • FmX'tal=32.768kHz crystal oscillation • System clock: RC oscillation • Divider: 1/2	2.4 to 3.6		0.16	0.4	
	IDDHALT(5)		HALT mode • FmCF=0Hz(Oscillation stop) • FmX'tal=32.768kHz crystal oscillation • System clock: variable RC oscillation 1MHz • Divider: 1/1	2.4 to 3.6		7.5	32	μA
	IDDHALT(6)		HALT mode • FmCF=0Hz(Oscillation stop) • FmX'tal=32.768kHz crystal oscillation • System clock: 32.768kHz • Internal RC oscillation stopped. • Divider: 1/2	2.4 to 3.6		5.5	27	
HOLD mode consumption current	IDDHOLD(1)		HOLD mode • CF1=V _{DD} or open (when using external clock)	2.4 to 3.6		0.03	10	
Timer HOLD mode consumption current	IDDHOLD(2)		Date/time clock HOLD mode • CF1=V _{DD} or open (when using external clock) • FmX'tal=32.768kHz crystal oscillation	2.4 to 3.6		3.8	24	

Note 7-1: The currents through the output transistors and the pull-up MOS transistors are ignored.

LC87F7032A

F-ROM Programming Characteristics at Ta = +10°C to +55°C, VSS1 = VSS2= 0V

Parameter	Symbol	Pin/Remarks	Conditions	Specification				
				VDD[V]	min	typ	max	unit
Onboard programming current	IDDFW(1)	VDD1	<ul style="list-style-type: none"> 128-byte programming Erasing current included 	3.0 to 3.6		15	40	mA
Programming time	tFW(1)		<ul style="list-style-type: none"> 128-byte programming Erasing current included Time for setting up 128-byte data is excluded. 	3.0 to 3.6		20	40	ms

UART (Full Duplex) Operating Conditions at Ta = +20°C to +70°C, VSS1 = VSS2= 0V

Parameter	Symbol	Pin/Remarks	Conditions	Specification				
				VDD[V]	min.	typ.	max.	unit
Transfer rate	UBR	UTX(S22), URX(S23)		2.4 to 3.6	16/3		8192/3	tCYC

Data length: 7, 8, and 9 bits (LSB first)

Stop bits: 1 bit (2-bit in continuous data transmission)

Parity bits: None

Example of 8-bit Data Transmission Mode Processing (Transmit Data=55H)

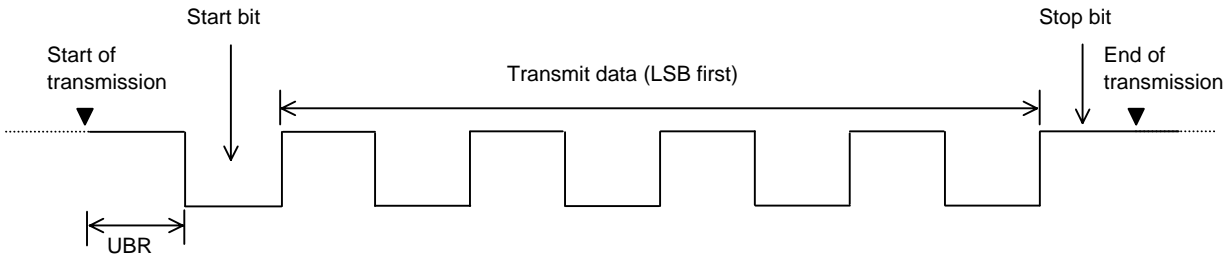

Example of 8-bit Data Reception Mode Processing (Receive Data=55H)

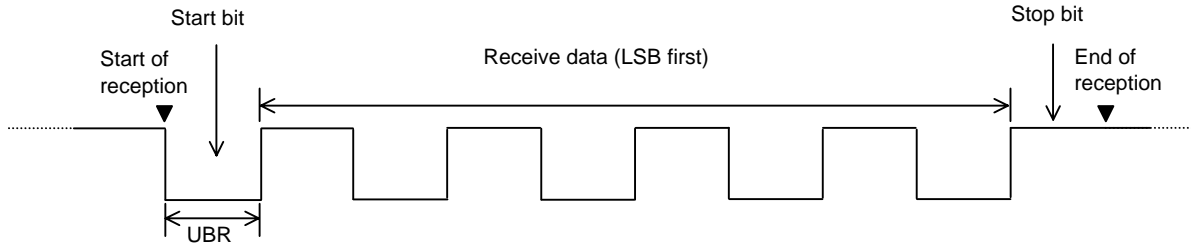

Main System Clock Oscillation Circuit Characteristics

The characteristics in the table below is based on the following conditions:

Use the standard evaluation board SANYO has provided.

Use the peripheral parts with indicated value externally.

The peripheral parts value is a recommended value of oscillator manufacturer

Table 1. Main system clock oscillation circuit characteristics using ceramic resonator

Frequency	Manufacturer	Type	Oscillator	Circuit parameters			Operating supply voltage range [V]	Oscillation stabilizing time		Notes
				C1 [pF]	C2 [pF]	Rd1 [Ω]		typ [ms]	max [ms]	
4.00MHz	Murata	SMD	CSTCR4M00G53-R0	(15)	(15)	1k	2.4 to 3.6	0.2	0.6	Built in C1, C2
		Lead	CSTLS4M00G53-B0	(15)	(15)	2.2k	2.4 to 3.6	0.2	0.6	

The oscillation stabilizing time is a period until the oscillation becomes stable after V_{DD} becomes higher than minimum operating voltage. (See Fig. 4.)

Subsystem Clock Oscillator Circuit Characteristics

The characteristics in the table below is based on the following conditions:

Use the standard evaluation board SANYO has provided.

Use the peripheral parts with indicated value externally.

The peripheral parts value is a recommended value of oscillator manufacturer

Table 2 Subsystem Clock Oscillation Circuit Characteristics Using Crystal Oscillator

Frequency	Manufacturer	Oscillator	Circuit Constant				Operating supply voltage range [V]	Oscillation Stabilization Time		Notes
			C3 [pF]	C4 [pF]	Rf [Ω]	Rd2 [Ω]		typ [s]	max [s]	
32.768kHz	Epson Toyocom	MC-146	3	3	Open	0	2.4 to 3.6	1	3	Applicable CL value=7.0pF

The oscillation stabilizing time is a period until the oscillation becomes stable after executing the instruction which starts the sub-clock oscillation or after releasing the HOLD mode. (See Fig. 4.)

Note: Since the circuit pattern affects the oscillation frequency, place the oscillation-related parts as close to the oscillation pins as possible with the shortest possible pattern length.

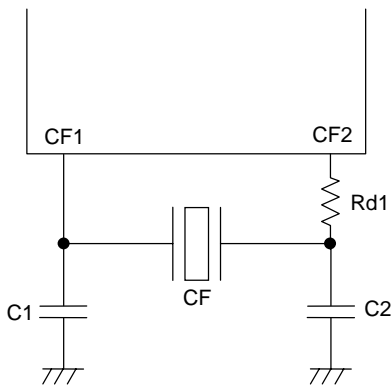

Figure 1 Ceramic Oscillator Circuit

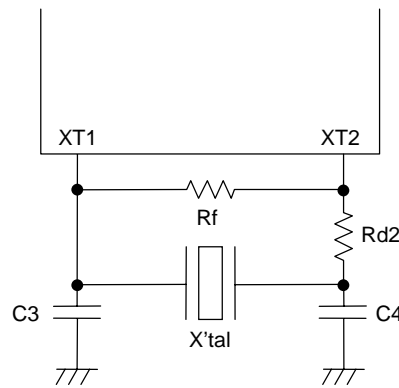

Figure 2 Crystal Oscillator Circuit

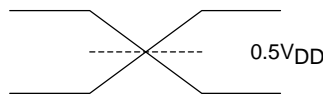
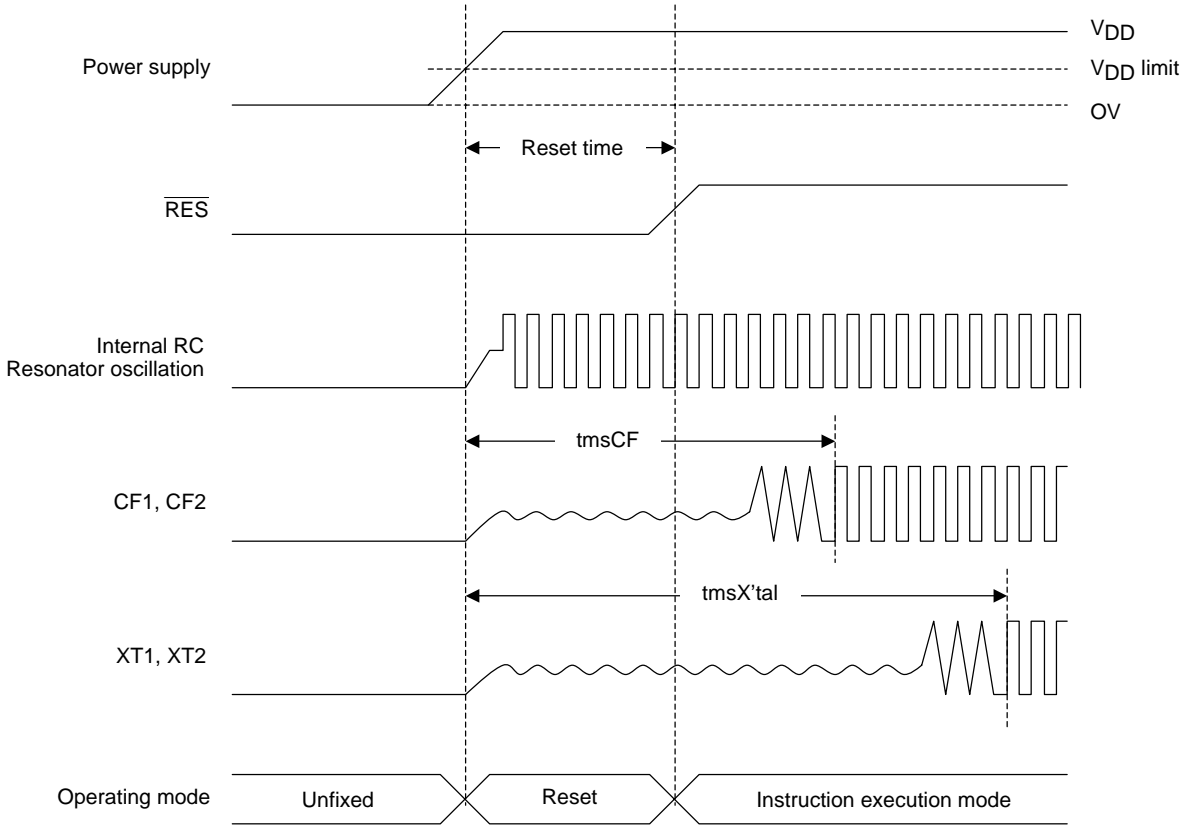
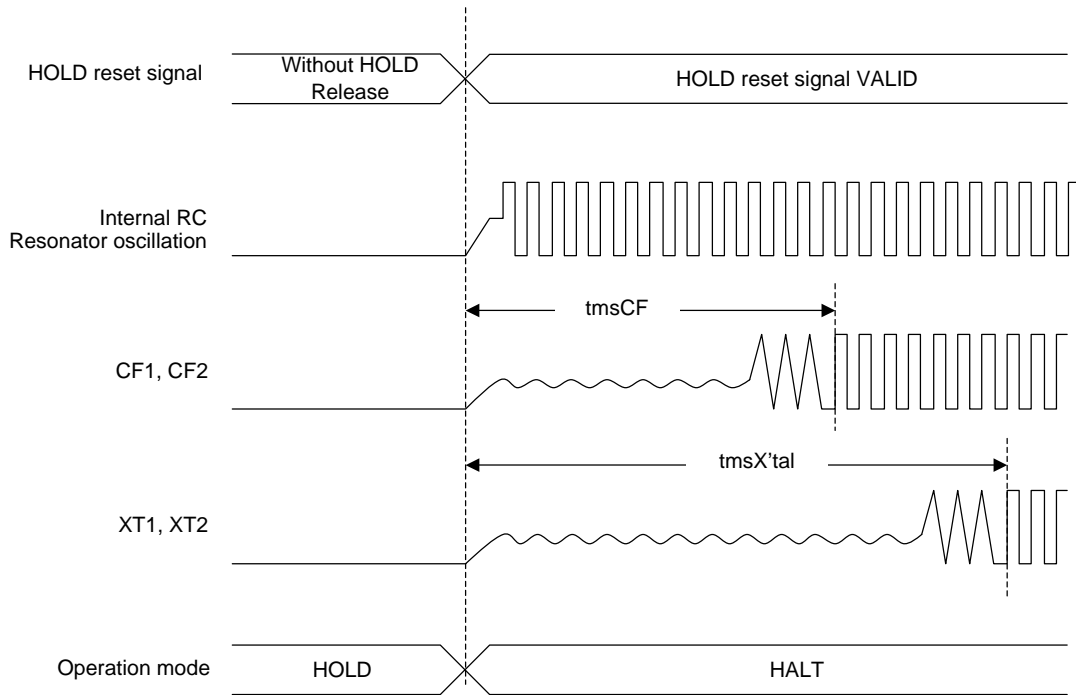

Figure 3 AC Timing Measurement Point



Reset Time and Oscillation Stabilizing Time



HOLD Release Signal and Oscillation Stable Time

Figure 4 Oscillation Stabilizing Time

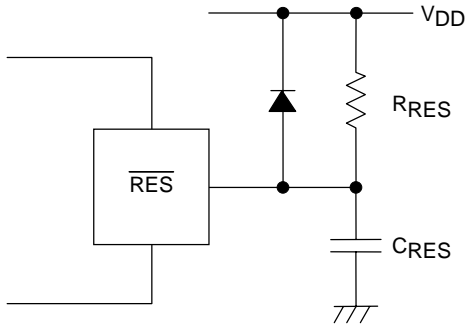

Note:
 Select C_{RES} and R_{RES} value to assure that at least $200\mu s$ reset time is generated after the V_{DD} becomes higher than the minimum operating voltage.

Figure 5 Reset Circuit

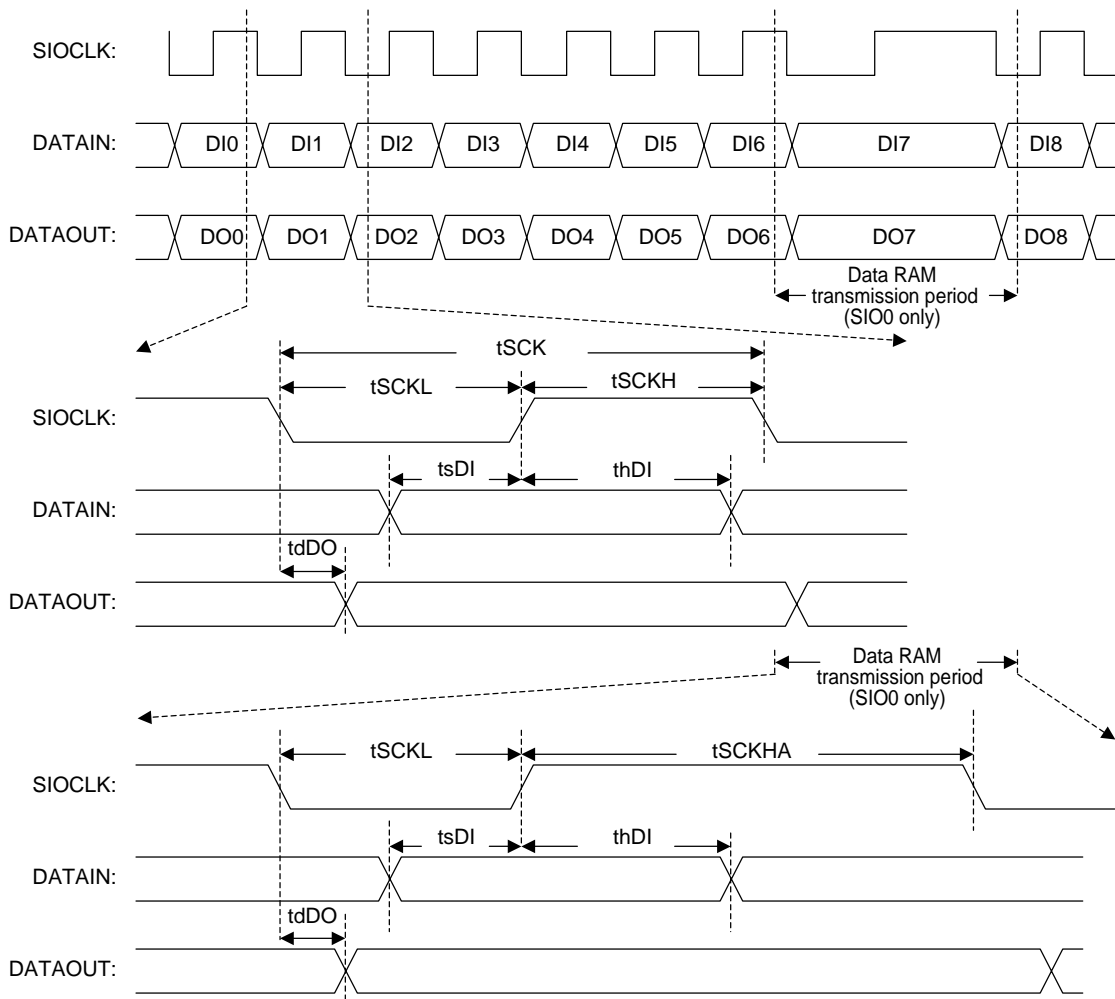

Figure 6 Serial Input/Output Wave Form

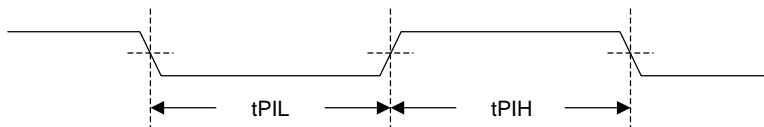

Figure 7 Pulse Input Timing Condition

- SANYO Semiconductor Co.,Ltd. assumes no responsibility for equipment failures that result from using products at values that exceed, even momentarily, rated values (such as maximum ratings, operating condition ranges, or other parameters) listed in products specifications of any and all SANYO Semiconductor Co.,Ltd. products described or contained herein.
- SANYO Semiconductor Co.,Ltd. strives to supply high-quality high-reliability products, however, any and all semiconductor products fail or malfunction with some probability. It is possible that these probabilistic failures or malfunction could give rise to accidents or events that could endanger human lives, trouble that could give rise to smoke or fire, or accidents that could cause damage to other property. When designing equipment, adopt safety measures so that these kinds of accidents or events cannot occur. Such measures include but are not limited to protective circuits and error prevention circuits for safe design, redundant design, and structural design.
- In the event that any or all SANYO Semiconductor Co.,Ltd. products described or contained herein are controlled under any of applicable local export control laws and regulations, such products may require the export license from the authorities concerned in accordance with the above law.
- No part of this publication may be reproduced or transmitted in any form or by any means, electronic or mechanical, including photocopying and recording, or any information storage or retrieval system, or otherwise, without the prior written consent of SANYO Semiconductor Co.,Ltd.
- Any and all information described or contained herein are subject to change without notice due to product/technology improvement, etc. When designing equipment, refer to the "Delivery Specification" for the SANYO Semiconductor Co.,Ltd. product that you intend to use.
- Information (including circuit diagrams and circuit parameters) herein is for example only; it is not guaranteed for volume production.
- Upon using the technical information or products described herein, neither warranty nor license shall be granted with regard to intellectual property rights or any other rights of SANYO Semiconductor Co.,Ltd. or any third party. SANYO Semiconductor Co.,Ltd. shall not be liable for any claim or suits with regard to a third party's intellectual property rights which has resulted from the use of the technical information and products mentioned above.

This catalog provides information as of February, 2007. Specifications and information herein are subject to change without notice.