



SANYO Semiconductors

DATA SHEET

An ON Semiconductor Company

LC88F85D0A — CMOS IC FROM 256K byte, RAM 8K byte on-chip 16-bit 1-chip Microcontroller

Overview

The LC88F85D0A is a 16-bit microcomputer that, centered around an Xstormy16 CPU core, integrates on a single chip a number of hardware features such as 256K bytes of flash ROM (onboard programmable), 8K bytes of RAM, five 16-bit timers, a time base timer, a synchronous SIO interface with automatic transfer function, a single-master I²C/synchronous SIO interface, two asynchronous SIO (UART) interfaces, a remote control receiver, LCD dedicated RAM, an LCD dot-matrix driver, a 12-bit-resolution 8-channel AD converter, a watchdog timer, a system clock frequency divider, and a 35-source 10-vector interrupt feature.

Features

■Xstormy16 CPU

- 4G-byte address space
- General-purpose registers: 16 bits × 16

■Flash ROM

- Onboard programmable with a wide range of supply voltages: 3.0 to 5.5V
- Block erasable in 512-byte/1K-byte units
- Data writing in 2-byte units
- 262144 × 8 bits

■RAM

- Data: 8192 × 8 bits
- LCD display: 128 × 16 bits

* This product is licensed from Silicon Storage Technology, Inc. (USA), and manufactured and sold by SANYO Semiconductor Co., Ltd.

■ Any and all SANYO Semiconductor Co.,Ltd. products described or contained herein are, with regard to "standard application", intended for the use as general electronics equipment (home appliances, AV equipment, communication device, office equipment, industrial equipment etc.). The products mentioned herein shall not be intended for use for any "special application" (medical equipment whose purpose is to sustain life, aerospace instrument, nuclear control device, burning appliances, transportation machine, traffic signal system, safety equipment etc.) that shall require extremely high level of reliability and can directly threaten human lives in case of failure or malfunction of the product or may cause harm to human bodies, nor shall they grant any guarantee thereof. If you should intend to use our products for applications outside the standard applications of our customer who is considering such use and/or outside the scope of our intended standard applications, please consult with us prior to the intended use. If there is no consultation or inquiry before the intended use, our customer shall be solely responsible for the use.

■ Specifications of any and all SANYO Semiconductor Co.,Ltd. products described or contained herein stipulate the performance, characteristics, and functions of the described products in the independent state, and are not guarantees of the performance, characteristics, and functions of the described products as mounted in the customer's products or equipment. To verify symptoms and states that cannot be evaluated in an independent device, the customer should always evaluate and test devices mounted in the customer's products or equipment.

SANYO Semiconductor Co., Ltd.

<http://semicon.sanyo.com/en/network>

LC88F85D0A

■ Minimum instruction cycle time (tCYC)

- 100ns (10MHz) $V_{DD} = 4.5$ to $5.5V$
- 125ns (8MHz) $V_{DD} = 3.0$ to $5.5V$
- 500ns (2MHz) $V_{DD} = 2.0$ to $5.5V$

■ Ports

- Normal withstand voltage I/O ports
Ports whose I/O direction specifiable in 1-bit units: 20 (P0n, P1n, P20 to P23)
- LCD (Pins COM16/SEG0 to COM31/SEG15 are multiplexed with COM and SEG.)
LCD driver bias power supply pins 4 (V_{LCD1} to V_{LCD4})
Step-up capacitor pins 2 (CUP00, CUP01)
16 common mode
Segment output 64 (SEG0 to SEG63)
Common output 16 (COM0 to COM15)
32 common mode
Segment output 48 (SEG16 to SEG63)
Common output 32 (COM0 to COM31)
- Oscillation dedicated ports 4 (XT1, XT2, CF1, CF2)
- Reset pin 1 (RESB)
- TEST pin 1 (TEST)
- LCD port power pins 2 (LCDVSS0, LCDVSS1)
- Power pins 2 (V_{DD} , V_{SS})

■ LCD

- LCD power supply : Capacitor step-up type
- Number of dots : 1024 (64 segments \times 16 commons) / 1536 (48 segments \times 32 commons)
- Contrast : Selectable from 16 levels
- LCD frame frequency : Selectable from 4 frequencies

■ Timers

- Timer 0: 16-bit timer that supports PWM/toggle outputs
 - <1> With 5-bit prescaler
 - <2> 8-bit PWM \times 2 / 8-bit timer + 8-bit PWM split mode selectable
 - <3> Clock source selectable from system clock, OSC0, OSC1, and internal RC oscillator
- Timer 1: 16-bit timer with a capture register
 - <1> With 5-bit prescaler
 - <2> Can be divided into 8-bit timer \times 2 channels
 - <3> Clock source selectable from system clock, OSC0, OSC1, and internal RC oscillator
- Timer 3: 16-bit timer that supports PWM/toggle outputs
 - <1> With 8-bit prescaler
 - <2> 8-bit timer \times 2 channels / 8-bit timer + 8-bit PWM split mode selectable
 - <3> Clock source selectable from system clock, OSC0, OSC1, and external events
- Timer 4: 16-bit timer that supports toggle output
 - <1> Clock source selectable from system clock and prescaler 0
- Timer 5: 16-bit timer that supports toggle output
 - <1> Clock source selectable from system clock and prescaler 0
 - * The prescaler 0 consists of 4 bits and its clock source is selectable from the system clock, OSC0, and OSC1.
- Base timer
 - <1> The clock can be selected from OSC0 (32.768kHz crystal oscillator) and the frequency-divided output of the system clock.
 - <2> Interrupts can be generated in 7 time schemes.

■ Realtime clock (RTC)

- <1> Calendar function from January 1, 2000 to December 31, 2799 (with automatic leap year compensation)
- <2> Independent counter configuration for century, year, month, day, hour, minute, and second
- <3> Programmable count clock correction function

■ Serial interfaces

- SIO0: 8-bit synchronous SIO
 - <1> LSB first/MSB first selectable
 - <2> Supports communication of less than 8 bits (1 to 8 bits specifiable).
 - <3> Built-in 8-bit baudrate generator (transfer clock cycles of 4 tCYC to 512 tCYC)
 - <4> Automatic continuous data transfer (9 to 32768 bits specifiable in 1-bit units)
 - <5> Interval function (interval time specifiable in 0 to 64 tSCK units)
 - <6> Wakeup function
- SMIIC0: Single-master I²C/8-bit synchronous SIO
 - Mode 0: Single-master master mode communication
 - Mode 1: 8-bit synchronous serial I/O (MSB first)
- UART0
 - <1> Data length: 8 bits (LSB first)
 - <2> Start bits: 1 bit
 - <3> Stop bits: 1 bit
 - <4> Parity bits: None/even parity/odd parity
 - <5> Transfer rate: 4/8 tCYC
 - <6> Baudrate clock source: The P07 input signal is used as a 1 cycle signal (TOPWMH can be used as the clock source) or a timer 4 period.
 - <7> Full duplex communication
- UART2
 - <1> Data length: 8 bits (LSB first)
 - <2> Start bits: 1 bit
 - <3> Stop bits: 1/2 bit
 - <4> Parity bit: None/even parity/odd parity
 - <5> Transfer rate: 8 to 4096 tCYC
 - <6> Baudrate clock source: System clock/OSC0/OSC1/P21 input signal
 - <7> Wakeup function
 - <8> Full duplex communication

■ AD converter

- <1> 8/12-bit resolution selectable
- <2> Analog inputs: 12 channels
- <3> Comparator mode
- <4> Automatic reference voltage generation

■ Watchdog timer

- <1> Runs on the base timer + internal watchdog timer dedicated counter.
- <2> Interrupt or reset signals selectable

■ Infrared remote control receiver

- <1> Noise rejection function
(Noise filter time constant: Approx. 120μs when the 32.768kHz crystal oscillator is selected as the reference clock source)
- <2> Supports PPM (Pulse Position Modulation), Manchester and other encoding systems.
- <3> HOLDX mode release function

■ Interrupts (peripheral function)

Either "Normal" or "LC888300 Compatible" mode is selectable by user option.

* Note: The "LC888300 Compatible" mode is an option that is available to provide compatibility between this model and the LC888300. It is to be unavailable in future developed models.

- <1> Provides three levels of multiplex interrupt control. Any interrupt request of the level equal to or lower than the current interrupt is not accepted.
- <2> When interrupt requests to two or more vector addresses occur at the same time, the interrupt of the highest level takes precedence over the other interrupts. For interrupts of the same level, the interrupt into the smallest vector address takes precedence.

LC88F85D0A

• Normal mode: 35 sources (15 modules), 10 vectors

No.	Vector	Interrupt Module
1	08000H	Watchdog timer (1)
2	08004H	Base timer (2)
3	08008H	Timer 0 (2)
4	08018H	Timer 1 (2)/UART2 (4)
5	0801CH	SMIIC0 (1)
6	08020H	Timer 3 (2)/infrared remote control receiver (4)
7	08024H	Timer 4 (1)
8	08030H	ADC (1)/timer 5 (1)
9	08038H	SIO0 (2)
10	0803CH	Port 0 (3)/RTC2 (1)/SEGINT (8)

• LC888300 Compatible mode: 35 sources (15 modules), 13 vectors

No.	Vector	Interrupt Module
1	08000H	Watchdog timer (1)
2	08004H	Base timer (2)
3	08008H	Timer 0 (2)
4	08018H	SIO0 (2)
5	0801CH	Timer 1 (2)
6	08020H	UART2 (4)
7	08024H	Timer 3 (2)
8	08028H	Timer 4 (1)
9	0802CH	Timer 5 (1)
10	08030H	ADC (1)
11	08034H	SMIIC0 (1)
12	08038H	Infrared remote control receiver (4)
13	0803CH	Port 0 (3)/RTC2 (1)/SEGINT (8)

• Priority levels X > H > L

- When interrupts of the same level occur at the same time, an interrupt with a smaller vector address is given priority.
- The number in parentheses indicates the number of sources in a module.

■ Subroutine stack: 8K-byte RAM area

- Subroutine calls that automatically save the PSW, interrupt vector call: 6 bytes
- Subroutine calls that do not automatically save the PSW: 4 bytes

■ Multiplication/division instructions

- 16 bits × 16 bits (18 tCYC execution time)
- 16 bits ÷ 16 bits (18 to 19 tCYC execution time)
- 32 bits ÷ 16 bits (18 to 19 tCYC execution time)

■ Oscillator circuits

- RC oscillator circuit (internal): For system clock
- CF oscillator circuit: For system clock (OSC1)
- RC oscillator circuit (external RCR1): For system clock (OSC1)
- Crystal oscillator circuit (Rf built-in): For low-speed system clock (OSC0) (option available)
- RC oscillator circuit (external RCR0): For low-speed system clock (OSC0)
- SLRC oscillator circuit (internal): For system clock (used during exception processing)

■ System clock frequency divider function

- Can run on low consumption current.
- Supports frequency-dividing of 1/1 to 1/128 of the system clock

■ Standby function

- HALT mode: Halts instruction execution while allowing the peripheral circuits to continue operation.
 - 1) Oscillation is not halted automatically.
 - 2) HALT mode is released by a system reset or an interrupt .

Continued on next page.

LC88F85D0A

Continued from preceding page.

- HOLD mode: Suspends instruction execution and the operation of the peripheral circuits.
 - 1) OSC1, RC, and OSC0 oscillations automatically stop.
 - 2) There are five ways of releasing the HOLD mode:
 - <1> Setting the reset pin to the low level
 - <2> Having an interrupt source established at port 0
 - <3> Having an interrupt source established at SIO0
 - <4> Having an interrupt source established at UART2
 - <5> Having an interrupt source established at SEGINT
- HOLDX mode: Suspends instruction execution and the operation of all the circuits except the peripheral circuits running on OSC0.
 - 1) OSC1 and RC oscillators automatically stop operation.
 - 2) OSC0 retains the state established when the HOLDX mode is entered.
 - 3) There are seven ways of releasing the HOLDX mode:
 - <1> Setting the reset pin to the low level
 - <2> Having an interrupt source established at port 0
 - <3> Having an interrupt source established at SIO0
 - <4> Having an interrupt source established at UART2
 - <5> Having an interrupt source established at SEGINT
 - <6> Having an interrupt source established in the base timer or RTC2 circuit
 - <7> Having an interrupt source established in the infrared remote control receiver circuit

■ On-chip debugger function

- Supports software debugging with the microcontroller mounted on the target board.
- Supports source line debugging, tracing, breakpoint manipulation, and realtime display.
- Single-wire communication

■ Operating temperature

- -20 to +75°C

■ Package form

- TQFP120 (14×14) (lead-free type)

■ Development tools

- On-chip debugger: EOCUIF1 + LC88F85D0A

Package Dimensions

unit : mm (typ)

3257A

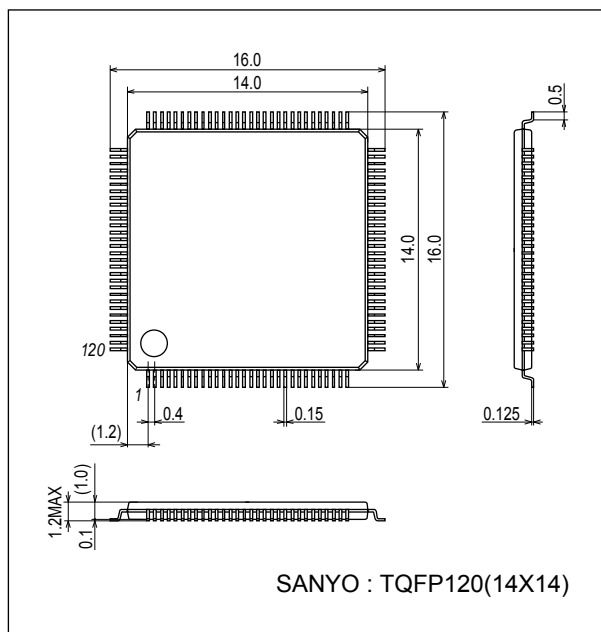

LC88F85D0A

Pad Assignment

- Chip size (X × Y) : 4.10mm × 3.40mm
- PAD opening siz : 59μm
- PAD pitch : 80μm
- Chip thickness : 280μm ± 20μm

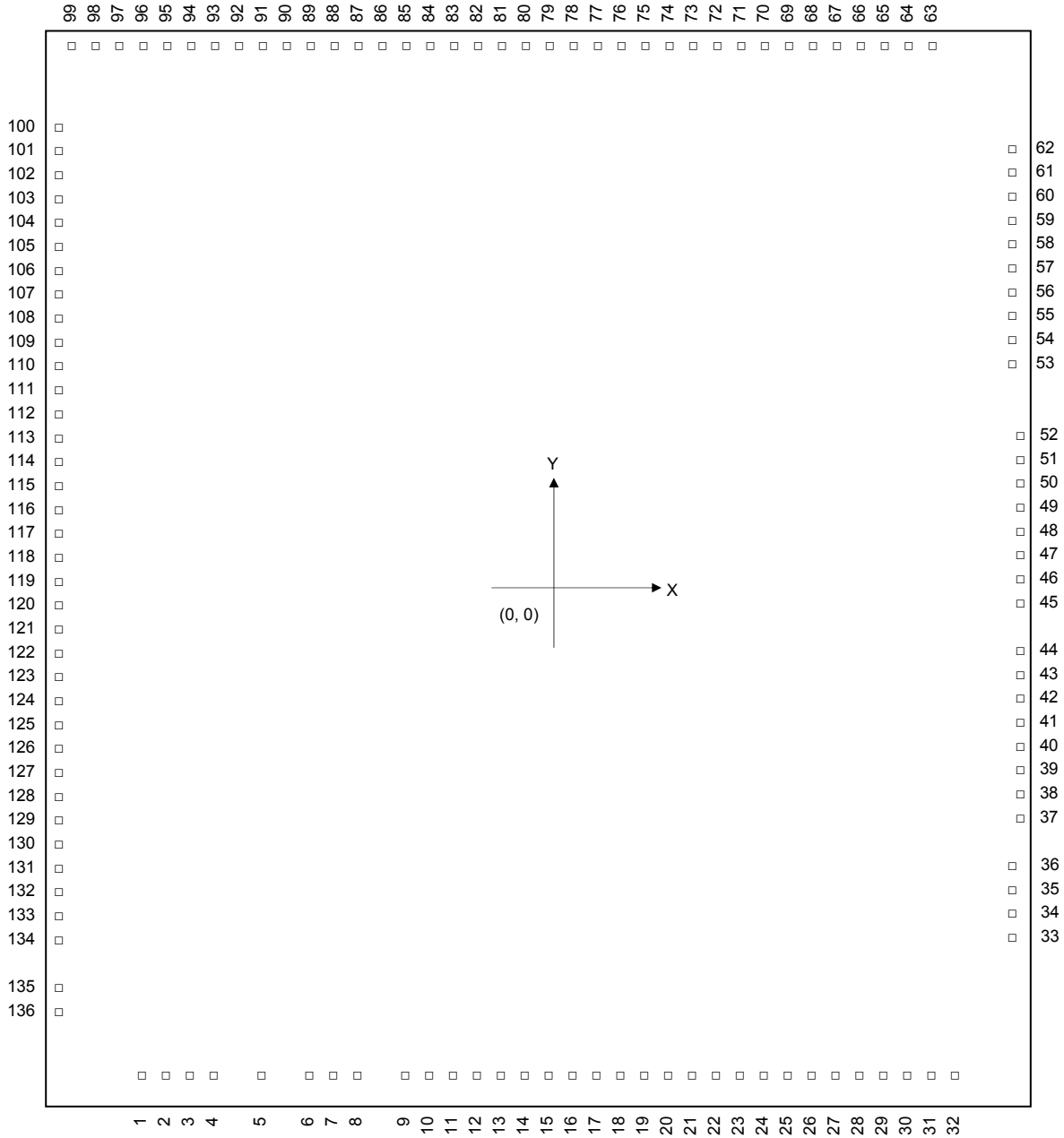

- Note: Package pin numbers differ from chip pad numbers. The numbers shown in the above figure are pad numbers.

LC88F85D0A

Table of PAD Coordinates

Pad No.	Pin Name	Coordinate		Pad No.	Pin Name	Coordinate	
		X μ m	Y μ m			X μ m	Y μ m
1	V _{LCD4}	-1647.9	-1569.9	48	SEG52	1958.5	208.2
2	V _{LCD3}	-1567.9	-1569.9	49	SEG51	1958.5	298.2
3	V _{LCD2}	-1483.2	-1569.9	50	SEG50	1958.5	388.2
4	V _{LCD1}	-1403.2	-1569.9	51	SEG49	1958.5	478.2
5	TST	-1184.0	-1569.9	52	SEG48	1958.5	568.2
6	XT2	-890.0	-1569.9	53	SEG47	1919.9	710.0
7	XT1	-781.5	-1569.9	54	SEG46	1919.9	790.0
8	RESB	-670.0	-1569.9	55	SEG45	1919.9	870.0
9	V _{DD}	-494.5	-1569.9	56	SEG44	1919.9	950.0
10		-374.5	-1569.9	57	SEG43	1919.9	1030.0
11		-263.5	-1569.9	58	SEG42	1919.9	1110.0
12	CF1	-165.0	-1569.9	59	SEG41	1919.9	1190.0
13	CF2	-85.0	-1569.9	60	SEG40	1919.9	1280.0
14	V _{SS}	10.0	-1569.9	61	SEG39	1919.9	1370.0
15		110.0	-1569.9	62	SEG38	1919.9	1460.0
16		210.0	-1569.9	63	LCDV _{SS} 1	1420.0	1569.9
17	P00	300.0	-1569.9	64	SEG37	1300.0	1569.9
18	P01	380.0	-1569.9	65	SEG36	1190.0	1569.9
19	P02	460.0	-1569.9	66	SEG35	1080.0	1569.9
20	P03	540.0	-1569.9	67	SEG34	990.0	1569.9
21	P04	620.0	-1569.9	68	SEG33	910.0	1569.9
22	P05	700.0	-1569.9	69	SEG32	830.0	1569.9
23	P06	780.0	-1569.9	70	SEG31	750.0	1569.9
24	P07	860.0	-1569.9	71	SEG30	670.0	1569.9
25	P10	940.0	-1569.9	72	SEG29	590.0	1569.9
26	P11	1020.0	-1569.9	73	SEG28	510.0	1569.9
27	P12	1100.0	-1569.9	74	SEG27	430.0	1569.9
28	P13	1180.0	-1569.9	75	SEG26	350.0	1569.9
29	P14	1260.0	-1569.9	76	SEG25	270.0	1569.9
30	P15	1340.0	-1569.9	77	SEG24	190.0	1569.9
31	P16	1420.0	-1569.9	78	SEG23	110.0	1569.9
32	P17	1500.0	-1569.9	79	SEG22	30.0	1569.9
33	P20	1919.9	-1415.0	80	SEG21	-50.0	1569.9
34	P21	1919.9	-1325.0	81	SEG20	-130.0	1569.9
35	P22	1919.9	-1192.0	82	SEG19	-210.0	1569.9
36	P23	1919.9	-1057.0	83	SEG18	-290.0	1569.9
37	SEG63	1958.5	-871.8	84	SEG17	-370.0	1569.9
38	SEG62	1958.5	-781.8	85	SEG16	-450.0	1569.9
39	SEG61	1958.5	-691.8	86	-	-	-
40	SEG60	1958.5	-601.8	87	COM31/SEG15	-620.0	1569.9
41	SEG59	1958.5	-511.8	88	-	-	-
42	SEG58	1958.5	-421.8	89	COM30/SEG14	-780.0	1569.9
43	SEG57	1958.5	-331.8	90	-	-	-
44	SEG56	1958.5	-241.8	91	COM29/SEG13	-940.0	1569.9
45	SEG55	1958.5	-61.8	92	-	-	-
46	SEG54	1958.5	28.2	93	COM28/SEG12	-1100.0	1569.9
47	SEG53	1958.5	118.2	94	-	-	-

Continued on next page.

LC88F85D0A

Continued from preceding page.

Pad No.	Pin Name	Coordinate		Pad No.	Pin Name	Coordinate	
		X μm	Y μm			X μm	Y μm
95	COM27/SEG11	-1260.0	1569.9	116	-	-	-
96	-	-	-	117	COM16/SEG0	-1919.9	60.0
97	COM26/SEG10	-1420.0	1569.9	118	COM15	-1919.9	-20.0
98	-	-	-	119	COM14	-1919.9	-100.0
99	COM25/SEG9	-1580.0	1569.9	120	COM13	-1919.9	-180.0
100	-	-	-	121	COM12	-1919.9	-260.0
101	COM24/SEG8	-1919.9	1340.0	122	COM11	-1919.9	-340.0
102	-	-	-	123	COM10	-1919.9	-420.0
103	COM23/SEG7	-1919.9	1180.0	124	COM9	-1919.9	-500.0
104	-	-	-	125	COM8	-1919.9	-580.0
105	COM22/SEG6	-1919.9	1020.0	126	COM7	-1919.9	-660.0
106	-	-	-	127	COM6	-1919.9	-740.0
107	COM21/SEG5	-1919.9	860.0	128	COM5	-1919.9	-820.0
108	-	-	-	129	COM4	-1919.9	-900.0
109	COM20/SEG4	-1919.9	700.0	130	COM3	-1919.9	-980.0
110	-	-	-	131	COM2	-1919.9	-1060.0
111	COM19/SEG3	-1919.9	540.0	132	COM1	-1919.9	-1140.0
112	-	-	-	133	COM0	-1919.9	-1220.0
113	COM18/SEG2	-1919.9	380.0	134	LCSV _{SS} 0	-1919.9	-1320.0
114	-	-	-	135	CUP00	-1919.9	-1443.3
115	COM17/SEG1	-1919.9	220.0	136	CUP01	-1919.9	-1523.3

Note:

- The coordinate values shown in the above table represent the coordinates of the pin pads measured with the center coordinates of the IC set to (0, 0).
- There are three pads for each of the V_{DD} and V_{SS} pins. They should be triple bonded.

LC88F85D0A

Pin Assignment

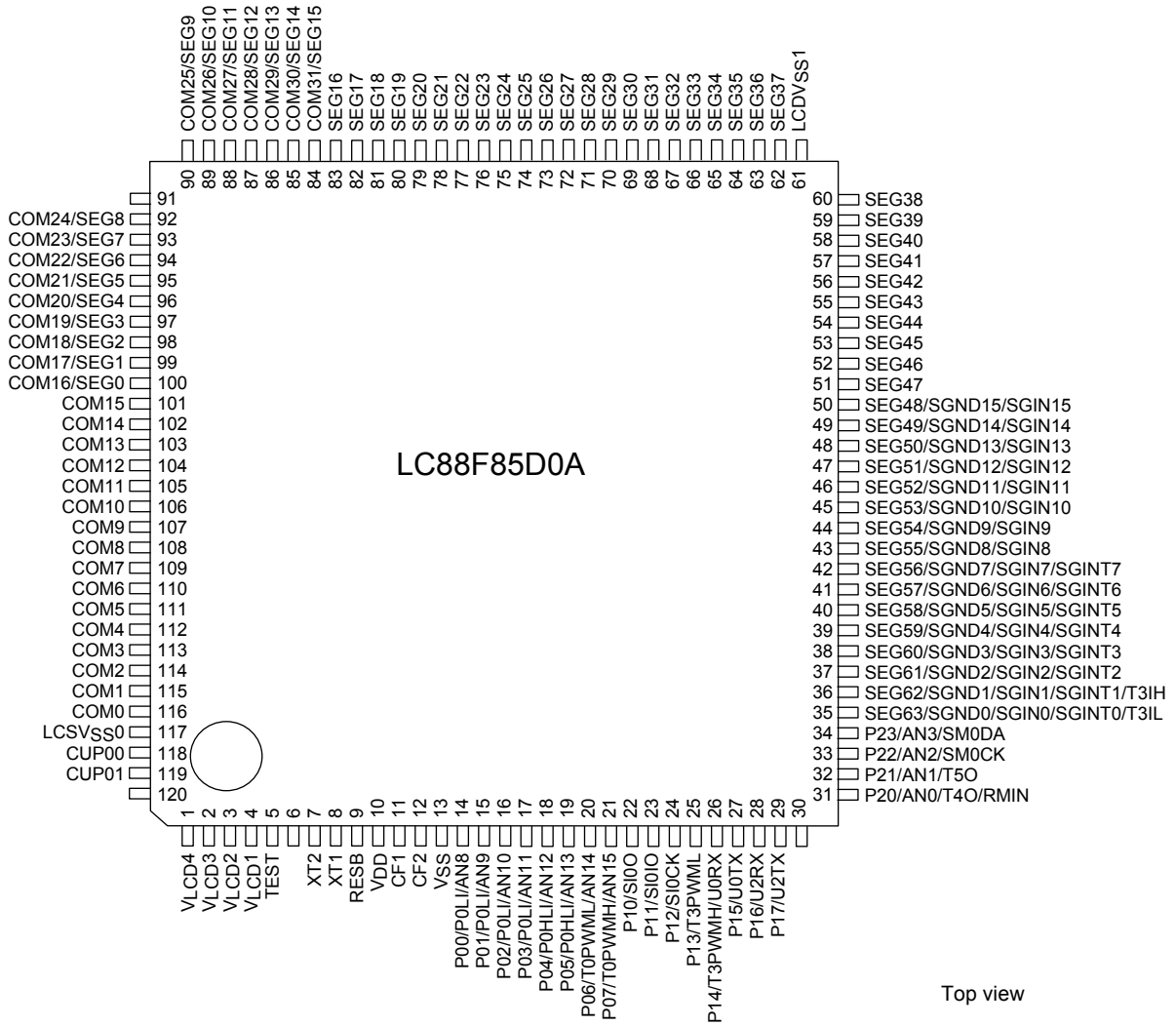

SANYO: TQFP120 (14×14) “Lead-free Type”

System Block Diagram

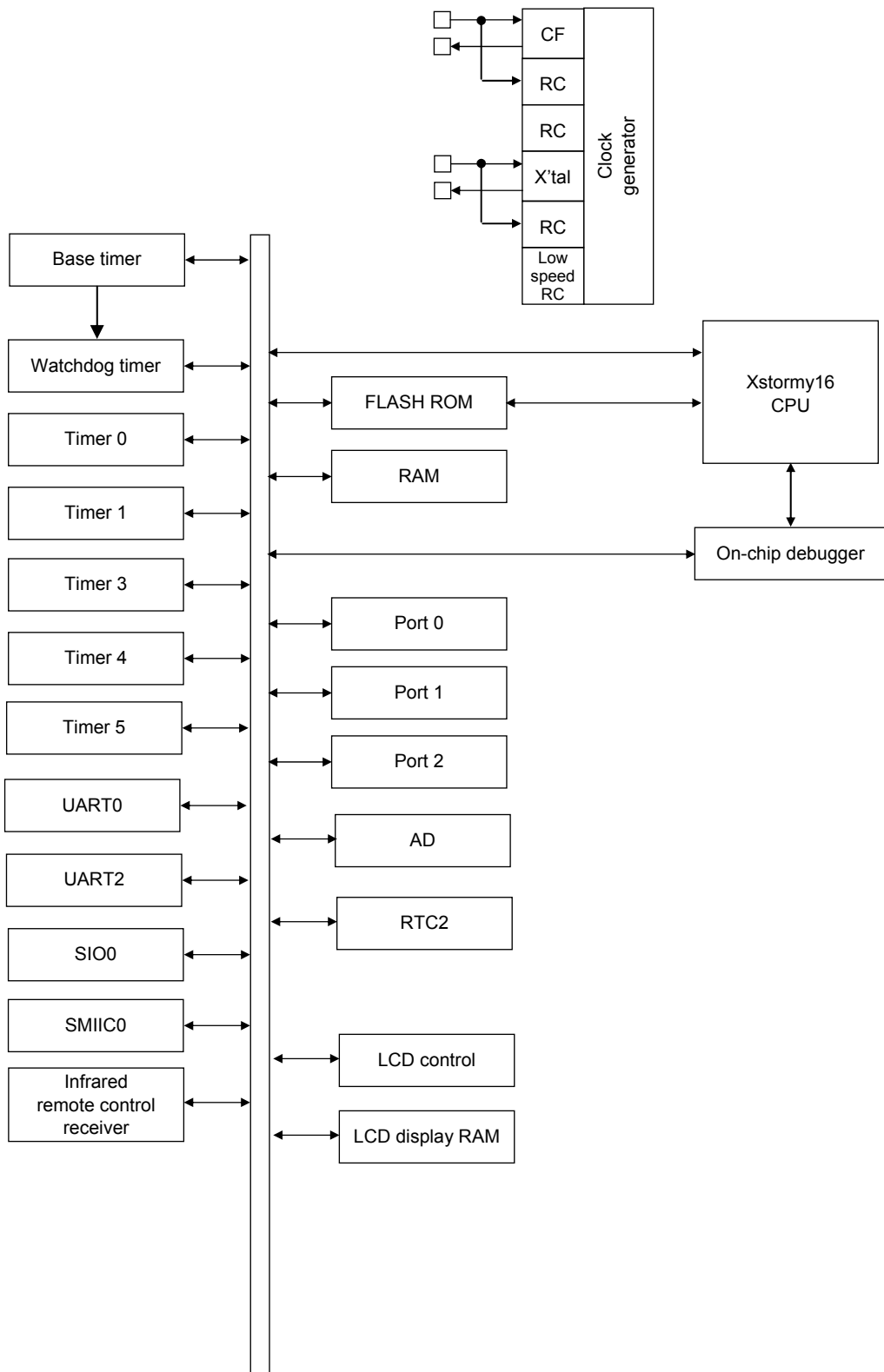

LC88F85D0A

Pin Description

Pin Name	I/O	Description
V _{SS}	-	- Power supply pin
V _{DD}	-	+ Power supply pin
V _{LCD1} to 4	-	LCD bias power source (connected to capacitors)
LCDV _{SS0} , LCDV _{SS1}	-	LCD port power source (-)
CUP00, CUP01	-	Switching pins for generating the LCD drive voltage. A capacitor must be connected across both pins.
PORT 0 P00 to P07	I/O	<ul style="list-style-type: none"> • 8-bit I/O port • I/O specifiable in 1 bit units • Pull-up registers can be turned on and off in 1-bit units. • HOLD releset inputs (P00 to P03, P04, P05) • Port 0 interrupt inputs (P00 to P03, P04, P05) • Pin functions <ul style="list-style-type: none"> P00 (AN8) to P07 (AN15): AD converter inputs P06: Timer 0L output P07: Timer 0H output/UART0 clock input
PORT 1 P10 to P17	I/O	<ul style="list-style-type: none"> • 8-bit I/O port • I/O specifiable in 1-bit units • Pull-up registers can be turned on and off in 1-bit units. • Pin functions <ul style="list-style-type: none"> P10: SIO0 data output P11: SIO0 data input/bus input/output P12: SIO0 clock input/output P13: Timer 3L output P14: Timer 3H output/UART0 receive P15: UART0 transmit P16: UART2 receive P17: UART2 transmit
PORT 2 P20 to P23	I/O	<ul style="list-style-type: none"> • 4-bit I/O port • I/O specifiable in 1-bit units • Pull-up registers can be turned on and off in 1-bit units. • Pin functions <ul style="list-style-type: none"> P20 (AN0) to P23 (AN3): AD converter inputs P20: Timer 4 output/remote controller receive P21: Timer 5 output P22: SMIIC0 clock input/output P23: SMIIC0 bus input/output/data input
COM0 to COM15	O	• LCD common output
COM16/SEG0 to COM31/SEG15	O	• LCD common output/segment output Common output/segment output switched by a register
SEG16 to SEG47	O	• LCD segment output
SEG48 to SEG63	I/O	<ul style="list-style-type: none"> • LCD segment output • SEG63-SEG48: General-purpose N-channel open drain output/general-purpose input SEG63-SEG48: LCD output in 4-bit units/general-purpose N-channel open drain output/general-purpose input selectable • SEG63-SEG56: Interrupt function (4-bit units) Chatter removal sampling frequency select (4-bit units) Level/edge sense mode select (4-bit units) Hi/low level or rising/falling edge sense mode select (1-bit units) • SEG63-SEG62: Timer 3 external input
TEST	I/O	<ul style="list-style-type: none"> • TEST pin • On-chip debugger communication pin • An external 100kΩ pull-down resistor must be connected.
RESB	I	Reset pin
CF1	I	Ceramic oscillator input/RC oscillator resistor to be connected
CF2	O	Ceramic oscillator output
XT1	I	32.768kHz crystal oscillator input/RC oscillator resistor to be connected
XT2	O	32.768kHz crystal oscillator output

LC88F85D0A

Port Output Types

The table below lists the types of port outputs and the presence/absence of a pull-up resistor. Data can be read into any input port even if it is in the output mode.

Port Name	Options Selected in Units of	Output Type	Pull-up Resistor
P00 to P07	1 bit	CMOS	Programmable
P10 to P17 P20 to P23	1 bit	Multiplexed pin outputs are programmable either as CMOS or N-channel open drain output.	Programmable
SEG48 to SEG63	4 bits	N-channel open drain (LCD segment output)	None

Table of User Options

Option Name	Option	Description
X'tal OSC (*1)	Normal	Normal XT mode
	Low Power	Low power XT mode
Interrupt Vector (*2)	Normal	Interrupt vector switching
	LC888300 Compatible	

*1 The circuit constant values of the external components and oscillation stabilization time differ between the normal XT mode and low power XT mode.

*2 The "LC888300 Compatible" mode is an option that is available to provide compatibility between this model and the LC888300. It is to be unavailable in future models.

LC88F85D0A

Application circuit

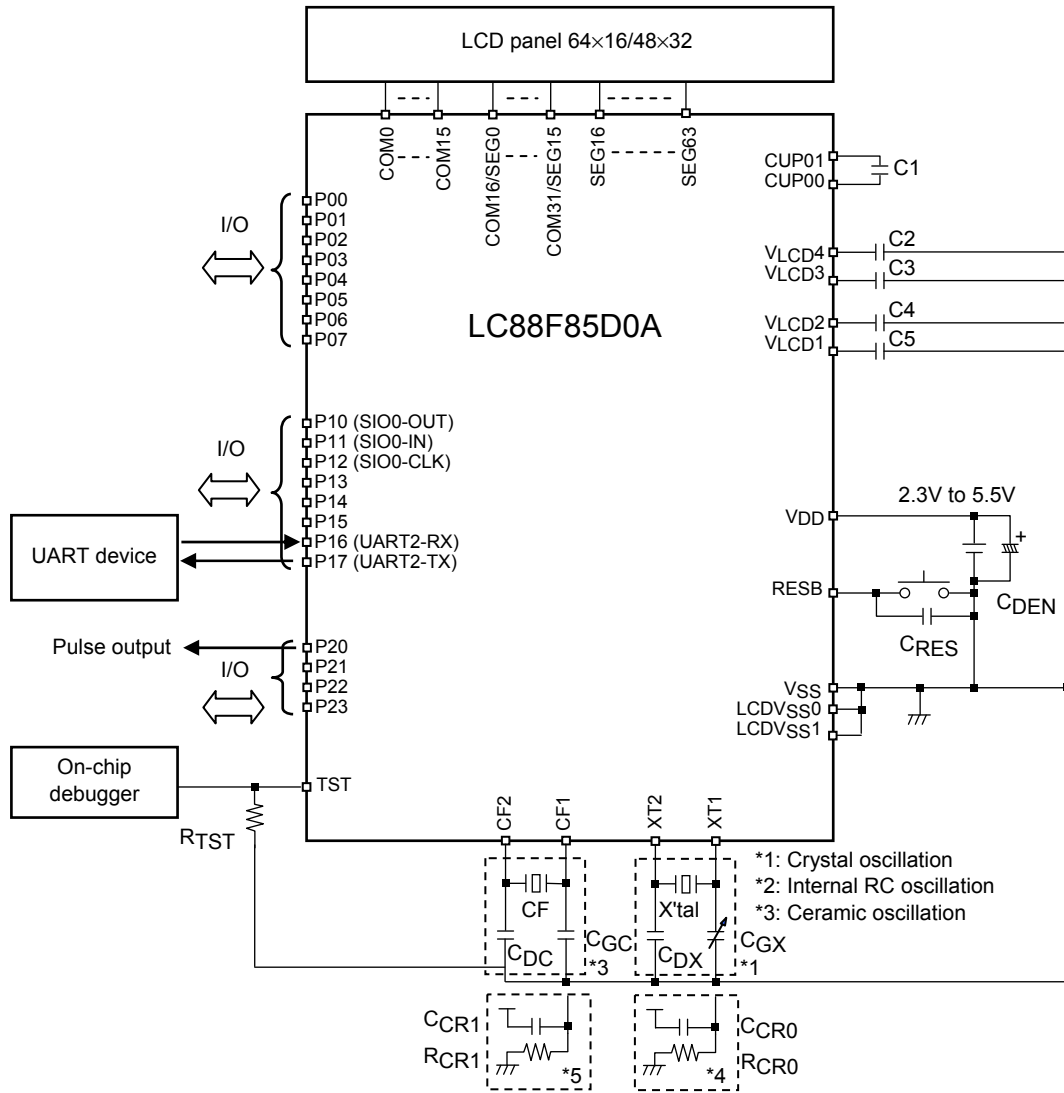

X'tal	Crystal resonator	
CGX	Trimmer capacitor	
CDX	Capacitor for X'tal oscillator	
RCR0	Resistor for low-speed oscillator	*4: RC oscillation type
CCR0	Capacitor for low-speed oscillation stabilization	*4: RC oscillation type (*1)
(*1)	0.1 μ F capacitor is recommended when using XT1/XT2 as the system clock source.	
CF	Ceramic resonator	
CGC	Capacitor for CF oscillator	
CDC	Capacitor for CF oscillator	
RCR1	Resistor for high-speed oscillator	*5: RC oscillation type
CCR1	Capacitor for high-speed oscillation stabilization	*5: RC oscillation type
C1 to C5	Capacitor	
CDEN	Electrolytic capacitor	
CRES	Capacitance for RESB	
RTST	Resistor used when using the on-chip debugger	

LC88F85D0A

Absolute Maximum Ratings at Ta = 25°C, VSS = LCDVSS0 = LCDVSS1 = 0V

Parameter	Symbol	Pin/Remarks	Conditions	Specification				unit
				V _{DD} [V]	min	typ	max	
Maximum supply voltage	V _{DD} max	V _{DD}	V _{DD}		-0.3		+6.5	V
LCD supply voltage	V _{LCD} max	V _{LCD} 2 to V _{LCD} 4	V _{DD}		-0.3		+6.5	
Maximum LCD supply voltage	LCD max	SEG0 to SEG63 COM0 to COM31	V _{DD} , V _{LCD} 4		-0.3		+6.5	
Input voltage	V _I (1)	CF1, XT1, RESB			-0.3		V _{DD} +0.3	
Input/output voltage	V _{IO} (1)	Ports 0, 1, 2 SEG63 to SEG48			-0.3		V _{DD} +0.3	
High level output current	Peak output current	IOPH(1)	Ports 0, 2	CMOS output select Per 1 applicable pin		-5		mA
		IOPH(2)	Port 1	Per 1 applicable pin		-14		
	Mean output current (Note 1-1)	IOMH(1)	Ports 0, 2	CMOS output select Per 1 applicable pin		-3		
		IOMH(2)	Port 1	CMOS output select Per 1 applicable pin		-9		
	Total output current	ΣIOAH(1)	Ports 0, 2	Total of all applicable pins		-22.5		
		ΣIOAH(2)	Port 1	Total of all applicable pins		-25		
ΣIOAH(3)		Ports 0, 1, 2	Total of all applicable pins		-47.5			
Low level output current	Peak output current	IOPL(1)	Ports 0, 2	Per 1 applicable pin			13	
		IOPL(2)	Port 1	Per 1 applicable pin			17	
	Mean output current (Note 1-1)	IOML(1)	Ports 0, 2	Per 1 applicable pin			7.5	
		IOML(2)	Port 1	Per 1 applicable pin			10.5	
	Total output current	ΣIOAL(1)	Ports 0, 2	Total of all applicable pins			35	
		ΣIOAL(2)	Port 1	Total of all applicable pins			60	
ΣIOAL(3)		Ports 0, 1, 2	Total of all applicable pins			80		
Allowable power dissipation	Pd max		Ta=-20 to +75°C				250	mW
Operating ambient temperature	Topr				-20		+75	°C
Storage ambient temperature	Tstg				-65		+125	

Note 1-1: The mean output current is a mean value measured over 100ms.

LC88F85D0A

Allowable Operating Conditions at $T_a = -20^{\circ}\text{C}$ to $+75^{\circ}\text{C}$, $V_{SS} = \text{LCDV}_{SS0} = \text{LCDV}_{SS1} = 0\text{V}$

Parameter	Symbol	Pin/Remarks	Conditions	Ratings				unit
				$V_{DD}[\text{V}]$	min	typ	max	
Operating supply voltage (Note2-1)	$V_{DD}(1)$	V_{DD}	$0.098\mu\text{s} \leq t_{CYC} \leq 66\mu\text{s}$		4.5		5.5	V
			$0.123\mu\text{s} \leq t_{CYC} \leq 66\mu\text{s}$		3.0		5.5	
			$0.490\mu\text{s} \leq t_{CYC} \leq 66\mu\text{s}$		2.0		5.5	
LCD drive voltage	$V_{LCD}(1)$	V_{LCD2} to V_{LCD4}					5.5	
Memory sustaining supply voltage	VHD	V_{DD}	RAM and register contents sustained in HOLD mode.		2.0		5.5	
High level input voltage	$V_{IH}(1)$	Ports 0, 1, 2	Output disabled		$0.30V_{DD} + 0.70$		V_{DD}	
	$V_{IH}(2)$	CF1, RESB			$0.75V_{DD}$		V_{DD}	
Low level input voltage	$V_{IL}(1)$	Ports 0, 1, 2	Output disabled		V_{SS}		$0.10V_{DD} + 0.40$	
	$V_{IL}(2)$	CF1, RESB			V_{SS}		$0.25V_{DD}$	
Instruction cycle time (Note 2-2)	tCYC			4.5 to 5.5	0.098		66	μs
				3.0 to 5.5	0.123		66	
				2.0 to 5.5	0.490		66	
External system clock frequency	FEXCF(1)	CF1	<ul style="list-style-type: none"> • CF2 pin open • System clock frequency division ratio=1/1 • External system clock duty=50±5% 	4.5 to 5.5	0.1		10	MHz
				3.0 to 5.5	0.1		8	
				2.0 to 5.5	0.1		2	
Oscillation frequency range (Note 2-3)	$F_{mCF}(1)$	CF1,CF2	10MHz ceramic oscillation See Fig. 1.	4.5 to 5.5		10		MHz
	$F_{mCF}(2)$	CF1,CF2	8MHz ceramic oscillation See Fig. 1.	3.0 to 5.5		8		
	$F_{mCF}(3)$	CF1,CF2	4MHz ceramic oscillation See Fig. 1.	2.4 to 5.5		4		
	F_{mRC}		Internal RC oscillation	2.0 to 5.5	0.5	1.0	2.0	kHz
	F_{mSLRC}		Internal SLRC oscillation	2.0 to 5.5	18	30	45	
	$F_{sX'tal}$	XT1, XT2	32.768kHz crystal oscillation See Fig. 2.	2.2 to 5.5		32.768		
	$F_{mRC1}(1)$	CF1	High-speed RC oscillation (Note 2-4)	2.4 to 5.5	400		4200	
	$F_{mRC1}(2)$	CF1	High-speed RC oscillation (Note 2-4)	2.0 to 5.5	400		2000	
F_{sRC0}	XT1	Low-speed RC oscillation (Note 2-4)	2.2 to 5.5	30		80		

Note2-1: V_{DD} must be held greater than or equal to 3.0V when onboard writing to flash ROM.

Note2-2: Relationship between tCYC and oscillation frequency is $1/F_{mCF}$ at a frequency division ratio of 1/1 and $2/F_{mCF}$ at a division ratio of 1/2.

Note2-3: See Tables 1 and 2 for the oscillation constants.

Note2-4: $T_a = 0^{\circ}\text{C}$ to 60°C

LC88F85D0A

Electrical Characteristics at Ta = -20°C to +75°C, VSS = LCDVSS0 = LCDVSS1 = 0V

Parameter	Symbol	Pin/Remarks	Conditions	Specification				
				V _{DD} [V]	min	typ	max	unit
High level input current	I _{IH} (1)	Ports 0, 1, 2 RESB	Output disabled Pull-up resistor off V _{IN} =V _{DD} (including output Tr off leakage current)	2.0 to 5.5			1	μA
Low level input current	I _{IL} (1)	Ports 0, 1, 2	Output disabled Pull-up resistor off V _{IN} =V _{SS} (including output Tr off leakage current)	2.7 to 5.5	-1			μA
High-level output voltage	V _{OH} (1)	Ports 0, 1, 2	I _{OH} =-1.0mA	4.5 to 5.5	V _{DD} -1			V
	V _{OH} (2)		I _{OH} =-0.4mA	3.0 to 5.5	V _{DD} -0.4			
	V _{OH} (3)		I _{OH} =-0.1mA	2.0 to 5.5	V _{DD} -0.4			
	V _{OH} (4)	COM0 to COM31	I _{OH} =-25μA	2.0 to 5.5	V _{LCD} ⁴ -0.05			
	V _{OH} (5)	SEG0 to SEG63	I _{OH} =-10μA	2.0 to 5.5	V _{LCD} ⁴ -0.05			
Low level output voltage	V _{OL} (1)	Ports 0, 1, 2	I _{OL} (1)=10mA	4.5 to 5.5			1.5	
	V _{OL} (2)		I _{OL} (1)=1.6mA	3.0 to 5.5		0.4		
	V _{OL} (3)		I _{OL} (1)=0.7mA	2.0 to 5.5		0.4		
	V _{OL} (4)	COM0 to COM31	I _{OL} H=25μA	2.0 to 5.5		V _{SS} +0.05		
	V _{OL} (5)	SEG0 to SEG63	I _{OL} =10μA	2.0 to 5.5		V _{SS} +0.05		
Pull-up resistance	R _{pu} (1)	Ports 0, 1, 2	V _{OH} =0.9V _{DD}	4.5 to 5.5	15	35	80	kΩ
	R _{pu} (2)			2.0 to 4.5	18	55	180	
Hysteresis voltage	V _{HYS}	Ports 0, 1, 2 RESB		2.0 to 5.5		0.1V _{DD}		V
Pin capacitance	CP	All pins	For pins other than that under test V _{IN} =V _{SS} f=1MHz Ta=25°C	2.0 to 5.5		10		pF

LC88F85D0A

LCD Drive Voltage at Ta = -20°C to +75°C, VSS = LCDVSS0 = LCDVSS1 = 0V

Special notes: 0.1μF capacitors are connected to VLCD1, VLCD2, VLCD3, and VLCD4. (with no panel load)

Parameter	Symbol	Pin/Remarks	Conditions	Specification				
				V _{DD} [V]	min	typ	max	unit
LCD drive voltage	VLCD1	V _{DD} VLCD1	Contrast "00"	2.0 to 5.5	Typ ×0.88	1.030	Typ ×1.10	V
			Contrast "01"			1.045		
			Contrast "02"			1.060		
			Contrast "03"			1.075		
			Contrast "04"			1.090		
			Contrast "05"			1.105		
			Contrast "06"			1.120		
			Contrast "07"			1.135		
			Contrast "08"			1.150		
			Contrast "09"			1.165		
			Contrast "10"			1.180		
			Contrast "11"			1.195		
			Contrast "12"			1.210		
			Contrast "13"			1.225		
			Contrast "14"			1.240		
			Contrast "15"			1.255		
	VLCD2					2×VLCD1		
	VLCD3					3×VLCD1		
	VLCD4					4×VLCD1		

LC88F85D0A

Serial I/O Characteristics at $T_a = -20^\circ\text{C}$ to $+75^\circ\text{C}$, $V_{SS} = \text{LCDV}_{SS0} = \text{LCDV}_{SS1} = 0\text{V}$

SIO0 Serial I/O Characteristics (When wakeup function is not in used) (Note 4-1-1)

Parameter	Symbol	Pin/Remarks	Conditions	$V_{DD}[\text{V}]$	Specification						
					min	typ	max	unit			
Serial clock	Input clock	Frequency	tSCK(1)	SCK0(P12)	2.0 to 5.5	4			tCYC		
		Low level pulse width	tSCKL(1)							2	
		High level pulse width	tSCKH(1)							2	
			tSCKHA(1)	<ul style="list-style-type: none"> Automatic communication mode See Fig. 6. 						6	
		tSCKHBSY(1a)	<ul style="list-style-type: none"> Automatic communication mode See Fig. 6. 	23							
		tSCKHBSY(1b)	<ul style="list-style-type: none"> Mode other than automatic communication mode See Fig. 6. 	4							
	Output clock	Frequency	tSCK(2)	SCK0(P12)	2.0 to 5.5	4			tSCK		
		Low level pulse width	tSCKL(2)	<ul style="list-style-type: none"> CMOS output type selected See Fig. 6. 						1/2	
		High level pulse width	tSCKH(2)							1/2	
			tSCKHA(2)	<ul style="list-style-type: none"> Automatic communication mode CMOS output type selected See Fig. 6. 						6	
		tSCKHBSY(2a)	<ul style="list-style-type: none"> Automatic communication mode CMOS output type selected See Fig. 6. 	4						23	
		tSCKHBSY(2b)	<ul style="list-style-type: none"> Mode other than automatic communication mode See Fig. 6. 	4							
Serial input	Data setup time	tsDI(1)	SIO(P11), SB0(P11)	2.0 to 5.5	0.03						
	Data hold time	thDI(1)							0.03		
Serial output	Output delay time	tdD0(1)	SIO(P10), SB0(P11)	2.0 to 5.5				1tCYC +0.05	μs		
		tdD0(2)								<ul style="list-style-type: none"> (Note4-1-2) 	1tCYC +0.05

Note 4-1-1: These specifications are theoretical values. Margins must be allowed according to the actual operating conditions.

Note 4-1-2: Specified with respect to the falling edge of SIOCLK. Specified as the time up to the time the output state is changed in the open drain output mode. See Fig. 6.

LC88F85D0A

SIO1 Serial I/O Characteristics (When wakeup function is not in used) (Note 4-2-1)

Parameter		Symbol	Pin/Remarks	Conditions	V _{DD} [V]	Specification				
						min	typ	max	unit	
Serial clock	Input clock	Period	tSCK(3)	SCK0(P12)	• See Fig. 6.	2.0 to 5.5	2			tCYC
		Low level pulse width	tSCKL(3)				1			
		High level pulse width	tSCKH(3)				1			
			tSCKHBSY(3)				2			
Serial input	Data setup time	tsDI(2)	SI0(P11), SB0(P11)	• Specified with respect to rising edge of SIOCLK. • See Fig. 6.	2.0 to 5.5	0.03			μs	
	Data hold time	thDI(2)				0.03				
Serial output	Input clock	Output delay time	tdD0(3)	SO0(P10), SB0(P11)	• (Note4-2-2)	2.0 to 5.5			1tCYC +0.05	

Note 4-2-1: These specifications are theoretical values. Margins must be allowed according to the actual operating conditions.

Note 4-2-2: Specified with respect to the falling edge of SIOCLK. Specified as the time up to the time the output state is changed in the open drain output mode. See Fig. 6.

SMIIC0 Simple SIO Mode I/O Characteristics

Parameter		Symbol	Pin/Remarks	Conditions	V _{DD} [V]	Specification				
						min	typ	max	unit	
Serial clock	Input clock	Period	tSCK(7)	SMOCK (P22)	• See Fig. 6.	2.0 to 5.5	4			tCYC
		Low level pulse width	tSCKL(7)				2			
		High level pulse width	tSCKH(7)				2			
	Output clock	Period	tSCK(8)	SMOCK (P22)	• CMOS output type selected • See Fig. 6.	2.0 to 5.5	4			tSCK
		Low level pulse width	tSCKL(8)				1/2			
		High level pulse width	tSCKH(8)				1/2			
Serial input	Data setup time	tsDI(5)	SM0DA (P23)	• Specified with respect to rising edge of SIOCLK • See Fig. 6.	2.0 to 5.5	0.03			μs	
	Data hold time	thDI(5)				0.03				
Serial output	Output clock	Output delay time	tdD0(7)	SM0DA (P23)	• Specified with respect to falling edge of SIOCLK • Specified as the time up to the beginning of output change . • See Fig. 6.	2.0 to 5.5			1tCYC +0.05	

Note 4-3-1: These specifications are theoretical values. Margins must be allowed according to the actual operating conditions.

LC88F85D0A

SMIIC0 I²C Mode I/O Characteristics

Parameter		Symbol	Pin/Remarks	Conditions	V _{DD} [V]	Specification				
						min	typ	max	unit	
Clock	Input clock	Period	tSCL	SM0CK (P22)	• See Fig. 8.	2.0 to 5.5	5			Tfilit
		Low level pulse width	tSCLL				2.5			
		High level pulse width	tSCLH				2			
	Output clock	Period	tSCLx	SM0CK (P22)	• Specified as the time up to the beginning of output change.	2.0 to 5.5	10			tSCL
		Low level pulse width	tSCLLx				1/2			
		High level pulse width	tSCLHx				1/2			
SM0CK, SM0DA pin input spike suppression time		tsp	SM0CK(P22) SM0DA(P23)	• See Fig. 8.	2.0 to 5.5			1	Tfilit	
Start-to-stop period bus release time	Input	tBUF	SM0CK(P22) SM0DA(P23)	• See Fig. 8.	2.0 to 5.5	2.5			Tfilit	
	Output	tBUFx	SM0CK(P22) SM0DA(P23)	<ul style="list-style-type: none"> • Standard clock mode • Specified as the time up to the beginning of output change. • High-speed clock mode • Specified as the time up to the beginning of output change. 		5.5			μs	
Start/restart condition hold time	Input	tHD;STA	SM0CK(P22) SM0DA(P23)	• When SMIIC register control bit I ² CSHDS=0	2.0 to 5.5	2.0			Tfilit	
				• See Fig. 8.						
	Output	tHD;STAx	SM0CK(P22) SM0DA(P23)	• Standard clock mode	2.0 to 5.5	4.1			μs	
				• Specified as the time up to the beginning of output change.						
Restart condition setup time	Input	tSU;STA	SM0CK(P22) SM0DA(P23)	• See Fig. 8.	2.0 to 5.5	1.0			Tfilit	
	Output	tSU;STAx	SM0CK(P22) SM0DA(P23)	<ul style="list-style-type: none"> • Standard clock mode • Specified as the time up to the beginning of output change. • High-speed clock mode • Specified as the time up to the beginning of output change. 		5.5			μs	

Continued on next page.

LC88F85D0A

Continued from preceding page.

Parameter	Symbol	Pin/Remarks	Conditions	Specification					
				V _{DD} [V]	min	typ	max	Unit	
Stop condition setup time	Input	tSU;STO	SM0CK(P22) SM0DA(P23)	• See Fig. 8.	2.0 to 5.5	1.0			Tfilt
	Output	tSU;STOx	SM0CK(P22) SM0DA(P23)	<ul style="list-style-type: none"> • Standard clock mode • Specified as the time up to the beginning of output change. • High-speed clock mode • Specified as the time up to the beginning of output change. 		4.9			μs
Data hold time	Input	tHD;DAT	SM0CK(P22) SM0DA(P23)	• See Fig. 8.	2.0 to 5.5	0			Tfilt
	Output	tHD;DATx	SM0CK(P22) SM0DA(P23)	• Specified as the time up to the beginning of output change.		1		1.5	
Data setup time	Input	tSU;DAT	SM0CK(P22) SM0DA(P23)	• See Fig. 8.	2.0 to 5.5	1			Tfilt
	Output	tSU;DATx	SM0CK(P22) SM0DA(P23)	• Specified as the time up to the beginning of output change.		1tSCL- 1.5Tfilt			
SM0CK, SM0DA pin fall time	Input	tF	SM0CK(P22) SM0DA(P23)	• See Fig. 8.	2.0 to 5.5			300	ns
	Output	tF	SM0CK(P22) SM0DA(P23)	• When SMIIC register control bits PSLW=1, P5V=1	5	20+0.1Cb		250	
				• When SMIIC register control bits PSLW=1, P5V=0	3	20+0.1Cb		250	
			• When SM0CK and SM0DA port outputs are placed in fast mode		3.0 to 5.5			100	
			• Cb≤400pF						

Note 4-4-1: These specifications are theoretical values. Margins must be allowed according to the actual operating conditions.

Note 4-4-2: Tfilt denotes the value that is determined by the values of register SMIC0BRG, bits 7 and 6 (BRP1, BRP0) and the system clock frequency.

BRP1	BRP0	Tfilt
0	0	tCYC×1
0	1	tCYC×2
1	0	tCYC×3
1	1	tCYC×4

Set up (BRP1, BRP0) so that Tfilt falls within the following range:

$$250\text{ns} \geq T\text{filt} > 140\text{ns}$$

Note 4-4-3: Cb denotes the total capacitance (in pF) of the loads connected to each bus. Cb ≤ 400pF

Note 4-4-4: The standard clock mode refers to a mode that is entered by configuring SMIC0BRG within the following ranges:

$$250\text{ns} \geq T\text{filt} > 140\text{ns}$$

BRDQ (bit 5) = 1

SCL frequency setting ≤ 100kHz

The high-speed clock mode refers to a mode that is entered by configuring SMIC0BRG as follows:

$$250\text{ns} \geq T\text{filt} > 140\text{ns}$$

BRDQ (bit 5) = 0

SCL frequency setting ≤ 400kHz

LC88F85D0A

UART0 Operating Conditions at Ta = -20 to +75°C, VSS = LCDVSS0 = LCDVSS1 = 0V

Parameter	Symbol	Pin/Remarks	Conditions	Specification				
				VDD[V]	min	typ	max	unit
Transfer rate	UBR0	U0RX(P14), U0TX(P15), U0BRG(P07)		2.0 to 5.5	4		8	tBGCYC

Note 4-5: tBGCYC denotes 1 period of the baudrate clock source.

UART2 Operating Conditions at Ta = -20 to +75°C, VSS = LCDVSS0 = LCDVSS1 = 0V

Parameter	Symbol	Pin/Remarks	Conditions	Specification				
				VDD[V]	min	typ	max	unit
Transfer rate	UBR2	U2RX(P16), U2TX(P17)		2.0 to 5.5	8		4096	tBGCYC

Note 4-6: tBGCYC denotes 1 period of the baudrate clock source.

Pulse Input Conditions at Ta = -20 to +75°C, VSS = LCDVSS0 = LCDVSS1 = 0V

Parameter	Symbol	Pin/Remarks	Conditions	Specification				
				VDD[V]	min	typ	max	unit
	tPIL(2)	RESB	Resettable.	2.0 to 5.5	10			μs

AD Converter Characteristics at Ta = -20 to +75°C, VSS = LCDVSS0 = LCDVSS1 = 0V

12-bits AD Conversion Mode

Parameter	Symbol	Pin/Remarks	Conditions	Specification				
				VDD[V]	min	typ	max	unit
Resolution	NAD	AN0(P20), AN1(P21), AN2(P22), AN3(P23), AN8(P00) to AN15(P07)		2.9 to 5.5		12		bit
Absolute accuracy	ETAD		(Note 6-1)	2.9 to 5.5			±16	LSB
Conversion time	TCAD12		Conversion time is calculated.	4.5 to 5.5	27		209	μs
				2.9 to 5.5	67		209	
Analog input voltage range	VAIN			2.9 to 5.5	VSS		VDD	V
Analog port input current	IAINH		VAIN=VDD	2.9 to 5.5			1	μA
	IAINL		VAIN=VSS	2.9 to 5.5	-1			

- Conversion time calculation method: $TCAD12 = ((52 / (\text{AD division ratio})) + 2) \times tCYC$

8-bits AD Conversion Mode

Parameter	Symbol	Pin/Remarks	Conditions	Specification				
				VDD[V]	min	typ	max	unit
Resolution	NAD	AN0(P20), AN1(P21), AN2(P22), AN3(P23), AN8(P00) to AN15(P07)		2.9 to 5.5		8		bit
Absolute accuracy	ETAD		(Note 6-1)	2.9 to 5.5			±1.5	LSB
Conversion time	TCAD8		Conversion time is calculated.	4.5 to 5.5	17		129	μs
				2.9 to 5.5	42		129	
Analog input voltage range	VAIN			2.9 to 5.5	VSS		VDD	V
Analog port input current	IAINH		VAIN=VDD	2.9 to 5.5			1	μA
	IAINL		VAIN=VSS	2.9 to 5.5	-1			

- Conversion time calculation method: $TCAD8 = ((32 / (\text{AD division ratio})) + 2) \times tCYC$

Note 6-1: The quantization error ($\pm 1/2\text{LSB}$) is excluded from the absolute accuracy.

Note 6-2: The conversion time refers to the interval from the time a conversion starting instruction is issued till the time the complete digital value against the analog input value is loaded in the result register.

The conversion time is twice the normal value when one of the following conditions occurs:

- The first AD conversion is executed in the 12-bit AD conversion mode after a system reset.
- The first AD conversion is executed after the AD conversion mode is switched from 8-bit to 12-bit AD conversion mode.

LC88F85D0A

Consumption Current Characteristics at Ta = -20 to +75°C, VSS = LCDVSS0 = LCDVSS1 = 0V

Parameter	Symbol	Pin/ Remarks	Conditions		Specification				unit	
					V _{DD} [V]	min	typ	max		
Normal mode consumption current (Note 7-1)	IDDOP(1)	V _{DD}	<ul style="list-style-type: none"> FOSC0=32.768kHz System clock set to FOSC0 side Internal RC oscillation stopped FOSC1=0Hz (oscillation stopped) Frequency division ratio set to 1/1 Normal XT mode [No panel load]	LCD display ON	2.0 to 5.5		87	170	μA	
	IDDOP(2)				2.0 to 3.6		44	110		
	IDDOP(3)			LCD display OFF	2.0 to 5.5		75	155		
	IDDOP(4)				2.0 to 3.6		35	95		
	IDDOP(5)			<ul style="list-style-type: none"> FOSC0=32.768kHz System clock set to FOSC0 side Internal RC oscillation stopped FOSC1=0Hz (oscillation stopped) Frequency division ratio set to 1/1 Low power XT mode [No panel load]	LCD display ON	2.0 to 5.5		53		100
	IDDOP(6)					2.0 to 3.6		35		65
	IDDOP(7)				LCD display OFF	2.0 to 5.5		48		92
	IDDOP(8)			2.0 to 3.6			31	55		
	IDDOP(9)			<ul style="list-style-type: none"> FmCF=10MHz ceramic oscillator FOSC0=0Hz (oscillation stopped) System clock set to 10MHz side Internal RC oscillation stopped Frequency division ratio set to 1/1 		4.5 to 5.5		8.4		15.2
	IDDOP(10)		<ul style="list-style-type: none"> FmCF=8MHz ceramic oscillator FOSC0=0Hz (oscillation stopped) System clock set to 8MHz side Internal RC oscillation stopped Frequency division ratio set to 1/1 			4.5 to 5.5		7.6	14.7	
	IDDOP(11)					3.0 to 4.5		5.8	11	
	IDDOP(12)				<ul style="list-style-type: none"> FmCF=4MHz ceramic oscillator FOSC0=0Hz (oscillation stopped) System clock set to 4MHz Internal RC oscillation stopped Frequency division ratio set to 1/2 		4.5 to 5.5		3.6	5.5
	IDDOP(13)					2.2 to 4.5		2.2	4.7	
	IDDOP(14)		<ul style="list-style-type: none"> System clock set to internal RC side Internal RC oscillation oscillated FOSC0=0Hz (oscillation stopped) FOSC1=0Hz (oscillation stopped) Frequency division ratio set to 1/1 				2.0 to 5.5		2.2	5.6
	IDDOP(15)					2.0 to 3.6		1.2	3.6	
	IDDOP(16)				<ul style="list-style-type: none"> FOSC1=1MHz R_{CR1}=470kΩ System clock set to FOSC1 side Internal RC oscillation stopped FOSC0=0Hz (oscillation stopped) Frequency division ratio set to 1/1 *Ta=0 to 60°C		2.0 to 5.5		1.5	2.6
	IDDOP(17)					2.0 to 3.6		1.0	2.5	
	IDDOP(18)		<ul style="list-style-type: none"> FOSC0=64kHz R_{CR0}=910kΩ System clock set to FOSC0 side Internal RC oscillation stopped FOSC1=0Hz (oscillation stopped) Frequency division ratio set to 1/1 *Ta=0 to 60°C			2.0 to 5.5		100	187	μA
	IDDOP(19)				2.0 to 3.6		62	120		

Note 7-1: The consumption current value includes none of the currents that flow into the output Tr and internal pull-up resistors.

Continued on next page.

LC88F85D0A

Continued from preceding page.

Parameter	Symbol	Pin/ Remarks	Conditions		Specification					
					V _{DD} [V]	min	typ	max	unit	
HALT mode consumption current (Note 7-2)	IDDHALT(1)	V _{DD}	HALT mode • FOSC0=32.768kHz • System clock set to FOSC0 side • Internal RC oscillation stopped • FOSC1=0Hz (oscillation stopped) • Frequency division ratio set to 1/1 • Normal XT mode [No panel load]	LCD display ON	2.0 to 5.5		45	110	μA	
	IDDHALT(2)				2.0 to 3.6		16	50		
	IDDHALT(3)			LCD display OFF	2.0 to 5.5		36	90		
	IDDHALT(4)				2.0 to 3.6		7.8	51		
	IDDHALT(5)		HALT mode • FOSC0=32.768kHz • System clock set to FOSC0 side • Internal RC oscillation stopped • FOSC1=0Hz (oscillation stopped) • Frequency division ratio set to 1/1 • Low power XT mode [No panel load]	LCD display ON	2.0 to 5.5		15.5	53		
	IDDHALT(6)				2.0 to 3.6		12	30		
	IDDHALT(7)			LCD display OFF	2.0 to 5.5		6.5	40		
	IDDHALT(8)				2.0 to 3.6		4	30		
	IDDHALT(9)		HALT mode • FmCF=10MHz ceramic oscillator • FOSC0=0Hz (oscillation stopped) • System clock set to 10MHz side • Internal RC oscillation stopped • Frequency division ratio set to 1/1		4.5 to 5.5		2.0	3.4		
	IDDHALT(10)		HALT mode • FmCF=8MHz ceramic oscillator • Internal RC oscillation stopped • FOSC0=0Hz (oscillation stopped) • System clock set to 8MHz side • Internal RC oscillation stopped • Frequency division ratio set to 1/1		4.5 to 5.5		1.7	2.9		
	IDDHALT(11)		HALT mode • FmCF=8MHz ceramic oscillator • Internal RC oscillation stopped • FOSC0=0Hz (oscillation stopped) • System clock set to 8MHz side • Internal RC oscillation stopped • Frequency division ratio set to 1/1		3.0 to 4.5		1.2	2.1		
	IDDHALT(12)		HALT mode • FmCF=4MHz ceramic oscillator • FOSC0=0Hz (oscillation stopped) • System clock set to 4MHz side • Internal RC oscillation stopped • Frequency division ratio set to 1/2		4.5 to 5.5		0.7	1.2		
	IDDHALT(13)		HALT mode • FmCF=4MHz ceramic oscillator • FOSC0=0Hz (oscillation stopped) • System clock set to 4MHz side • Internal RC oscillation stopped • Frequency division ratio set to 1/2		2.2 to 4.5		0.3	0.85		
	IDDHALT(14)		HALT mode • System clock set to internal RC side • Internal RC oscillation oscillated • FOSC0=0Hz (oscillation stopped) • FOSC1=0Hz (oscillation stopped) • Frequency division ratio set to 1/1		2.0 to 5.5		0.7	1.3		
	IDDHALT(15)		HALT mode • System clock set to internal RC side • Internal RC oscillation oscillated • FOSC0=0Hz (oscillation stopped) • FOSC1=0Hz (oscillation stopped) • Frequency division ratio set to 1/1		2.0 to 3.6		0.3	0.6		
	IDDHALT(16)		HALT mode • FOSC1=1MHz R _{CR1} =470kΩ • System clock set to FOSC1 side • Internal RC oscillation stopped • FOSC0=0Hz (oscillation stopped) • Frequency division ratio set to 1/1 *Ta=0 to 60°C		2.0 to 5.5		0.2	0.5		
	IDDHALT(17)		HALT mode • FOSC1=1MHz R _{CR1} =470kΩ • System clock set to FOSC1 side • Internal RC oscillation stopped • FOSC0=0Hz (oscillation stopped) • Frequency division ratio set to 1/1 *Ta=0 to 60°C		2.0 to 3.6		0.1	0.3		
	IDDHALT(18)		HALT mode • FOSC0=64kHz R _{CR0} =910kΩ • System clock set to FOSC0 side • Internal RC oscillation stopped • FOSC1=0Hz (oscillation stopped) • Frequency division ratio set to 1/1 *Ta=0 to 60°C		2.0 to 5.5		20	60		μA
	IDDHALT(19)		HALT mode • FOSC0=64kHz R _{CR0} =910kΩ • System clock set to FOSC0 side • Internal RC oscillation stopped • FOSC1=0Hz (oscillation stopped) • Frequency division ratio set to 1/1 *Ta=0 to 60°C		2.0 to 3.6		10	40		

Note 7-2: The consumption current value includes none of the currents that flow into the output Tr and internal pull-up resistors.

Continued on next page.

LC88F85D0A

Continued from preceding page.

Parameter	Symbol	Pin/ Remarks	Conditions	Specification				
				V _{DD} [V]	min	typ	max	unit
HOLD mode consumption current	IDDHOLD(1)	V _{DD}	HOLD mode • CF1=V _{DD} or open (external clock mode)	2.0 to 5.5		0.08	35	μA
	IDDHOLD(2)			2.0 to 3.6		0.02	25	
HOLDX mode consumption current	IDDHOLD(3)		HOLDX mode • CF1=V _{DD} or open (external clock mode) • FOSC0=32.768kHz • Normal XT mode	2.0 to 5.5		30	65	
	IDDHOLD(4)			2.0 to 3.6		5	55	
	IDDHOLD(5)			2.0 to 5.5		0.6	35	
	IDDHOLD(6)			2.0 to 3.6		0.4	25	

Note 7-3: The consumption current value includes none of the currents that flow into the output Tr and internal pull-up resistors.

F-ROM Writing Characteristics at Ta = +10°C to +55°C, V_{SS} = LCDV_{SS0} = LCDV_{SS1} = 0V

Parameter	Symbol	Pin/ Remarks	Conditions	Specification				
				V _{DD} [V]	min	typ	max	unit
Onboard writing current	IDDFW(1)	V _{DD}	• Excluding power dissipation in the microcontroller block	3.0 to 5.5			15	mA
Writing time	tFW(1)		• 512-/1K-byte erase operation	3.0 to 5.5			30	ms
	tFW(2)		• 2-byte writing operation	3.0 to 5.5			60	μs

Characteristics of a Sample OSC1 System Clock Oscillation Circuit

Sample main system clock oscillation circuit characteristics

Given below are the characteristics of a sample main system clock oscillation circuit that are measured using a SANYO-designated oscillation characteristics evaluation board and external components with circuit constant values with which the oscillator vendor confirmed normal and stable oscillation.

Table 1 Characteristics of the Main System Clock Oscillation Circuit that Uses a Ceramic Oscillator

Nominal Frequency	Vendor Name	Oscillator Name	Circuit Constant				Operating Voltage Range [V]	Oscillation Stabilization Time		Remarks
			C3 [pF]	C4 [pF]	Rf [Ω]	Rd2 [Ω]		Typ [ms]	max [ms]	
10MHz	MURATA Manufacturing Co., Ltd.	CSTCE10M0G52-R0	(10)	(10)	OPEN	150	2.4 to 5.5	0.02	0.5	C1 and C2 integrated type
8MHz		CSTCE8M00G52-R0	(10)	(10)	OPEN	470	2.4 to 5.5	0.02	0.5	C1 and C2 integrated type
4MHz		CSTCR4M00G53-R0	(15)	(15)	OPEN	1.5K	2.2 to 5.5	0.02	0.5	C1 and C2 integrated type
		CSTCR4M00G53095-R0	(15)	(15)	OPEN	1.5K	2.0 to 5.5	0.02	0.5	C1 and C2 integrated type

The oscillation stabilization time refers to the time interval that is required for the oscillation to get stabilized after V_{DD} exceeds its lower limit operating voltage (see Figure 4).

Characteristics of a Sample Subsystem Clock Oscillation Circuit

Given below are the characteristics of a sample subsystem clock oscillation circuit that are measured using a SANYO-designated oscillation characteristics evaluation board and external components with circuit constant values with which the oscillator vendor confirmed normal and stable oscillation.

Table 2 Characteristics of a Sample Subsystem Clock Oscillator Circuit that uses a Crystal Oscillator

	Nominal Frequency	Vendor Name	Oscillator Name	Circuit Constant				Remarks
				C3 [pF]	C4 [pF]	Rf2 [Ω]	Rd2 [Ω]	
Normal XT mode	32.768kHz	TBD	TBD	TBD	TBD	TBD	TBD	
Low power XT mode	32.768kHz	TBD	TBD	TBD	TBD	TBD	TBD	

The oscillation stabilization time refers to the time interval that is required for the oscillation to get stabilized after an instruction for starting the subclock oscillator circuit is issued or the time interval that is required for the oscillation to get stabilized after the HOLD mode is released (see Figure 4).

Note: The components that are involved in oscillation should be placed as close to the IC and to one another as possible because they are vulnerable to the influences of the circuit pattern.

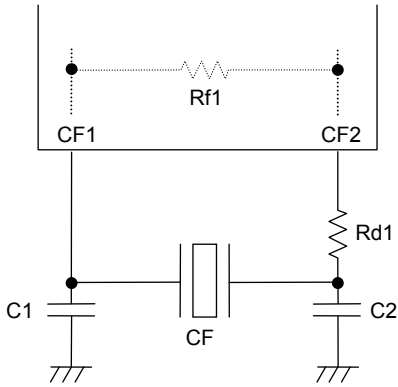

Figure 1 CF Oscillator Circuit

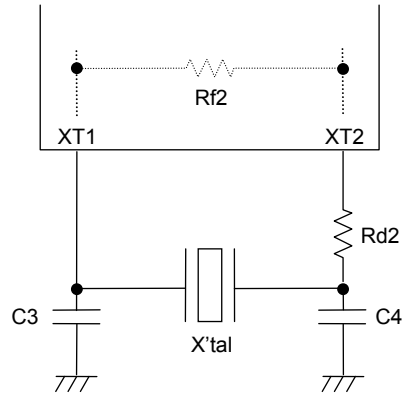

Figure 2 XT Oscillator Circuit

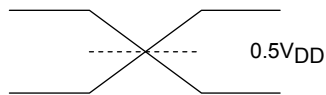
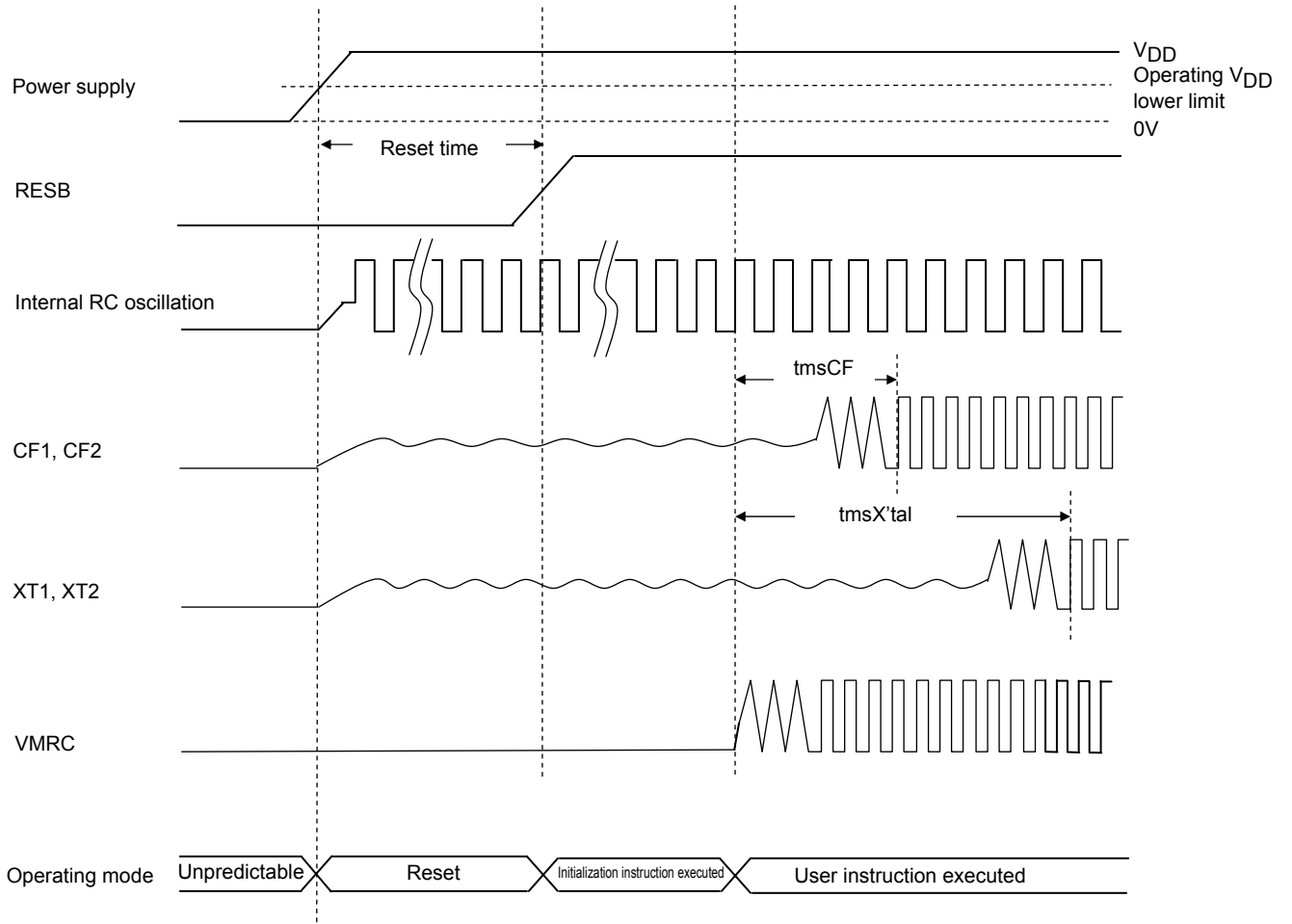
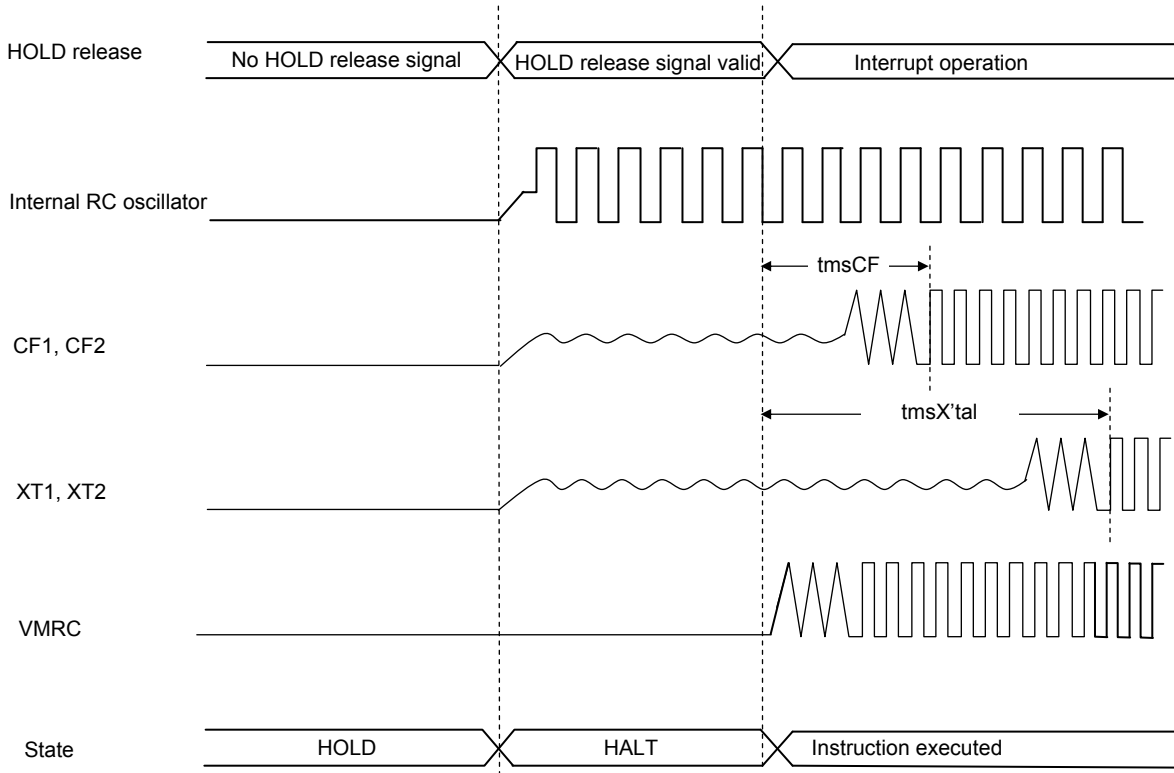

Figure 3 AC Timing Measurement Point

LC88F85D0A



Reset Time and Oscillation Stabilization Time



HOLD Reset and Oscillation Stabilization Time

Figure 4 Oscillation Stabilization Time

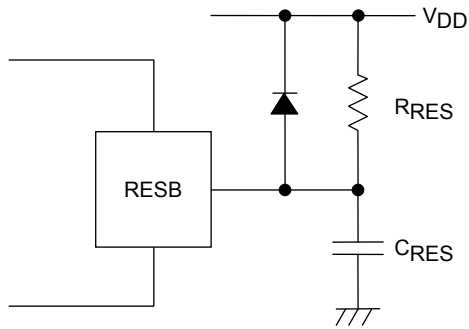

Note:
Make sure that reset is in effect when power is turned on. Determine the values of C_{RES} and R_{RES} so that the reset is in effect for a period of $10\mu s$ after the power gets stabilized.

Figure 5 Reset Circuit

LC88F85D0A

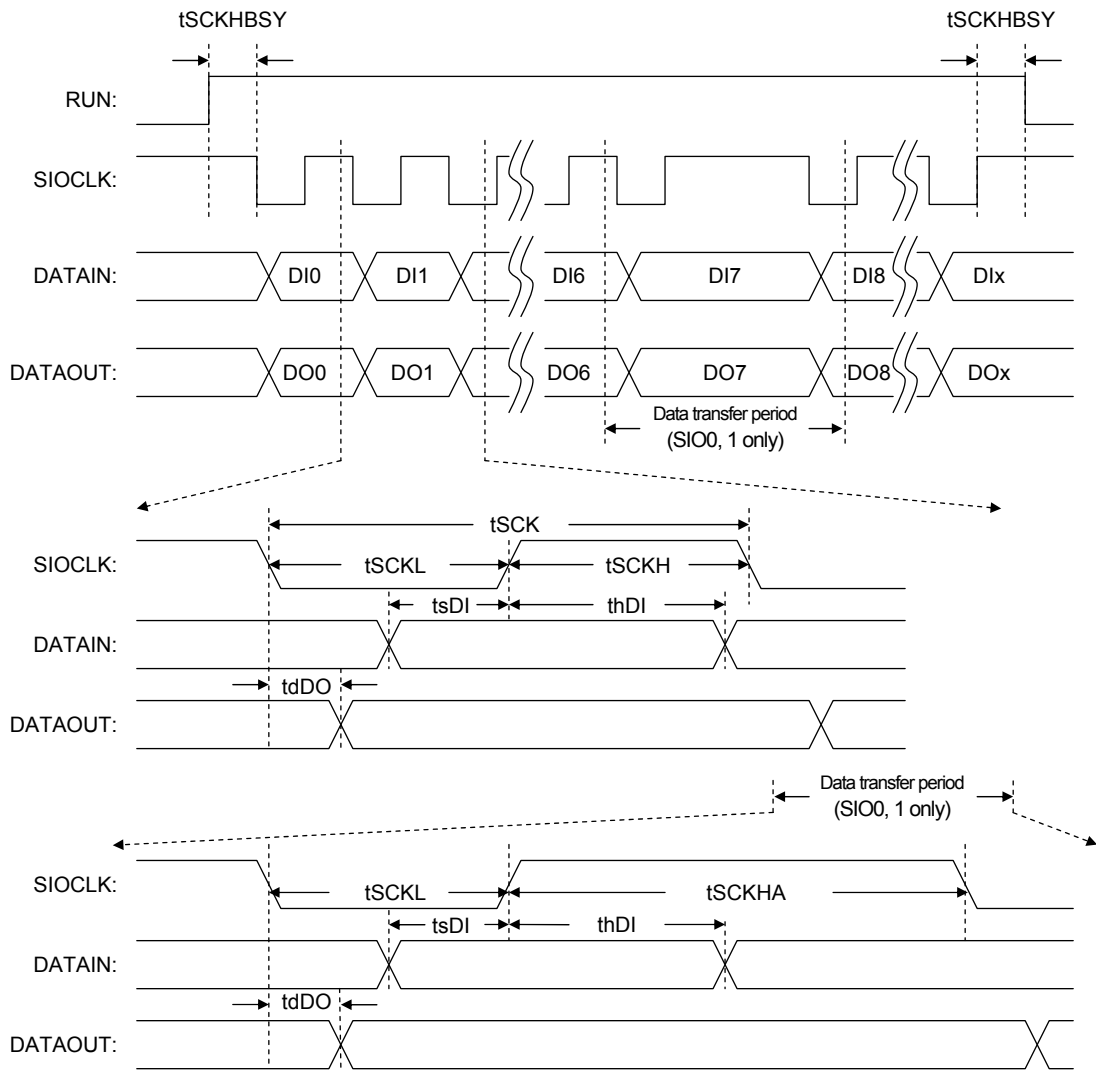

*: Remarks: DI_x and DO_x are the final communication bits. $X = 0$ to 32768

Figure 6 Serial I/O Waveforms Examples

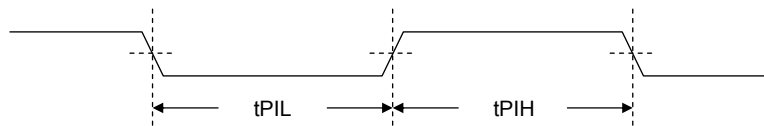
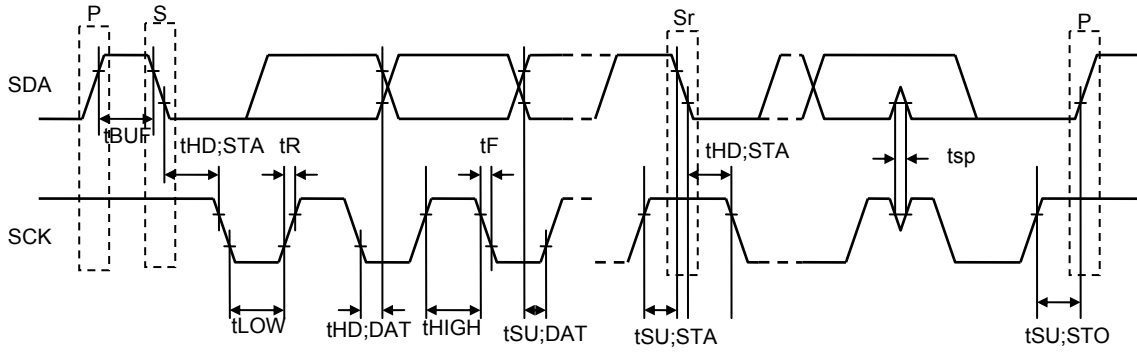

Figure 7 Pulse Input Timing Signal Waveform



S: Start condition
 P: Stop condition
 Sr: Restart condition

Figure 8 I²C Timing

Note: The oscillation frequency of any RC oscillator using OSC1 or OSC0 varies according to the printed circuit patterns and components mounted on the board. It also varies greatly according to the shape and form of the product (chip, plastic package, etc.) and board capacitance. Consequently, the characteristics charts given below should be used merely as reference values and the resistance value be determined after evaluating them with the actual product.

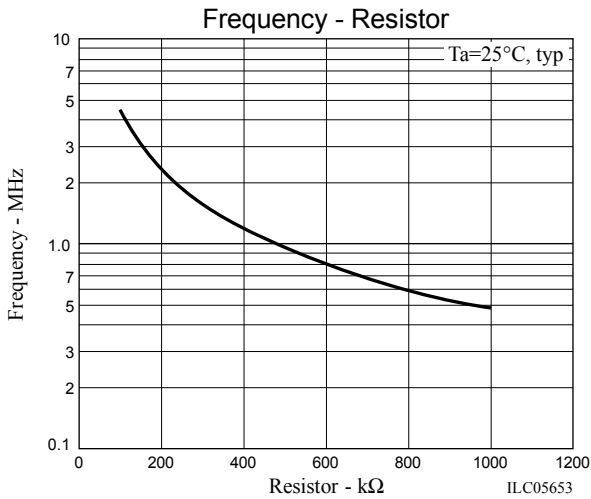

Figure 9 OSC1 Oscillation Frequency vs. Resistance Characteristics

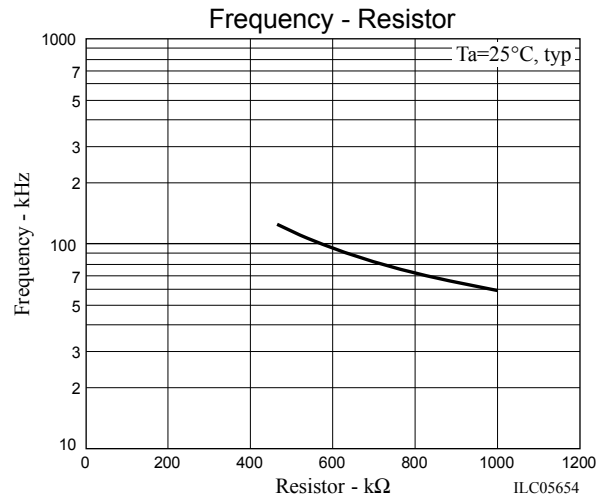

Figure 10 OSC0 Oscillation Frequency vs. Resistance Characteristics

- SANYO Semiconductor Co.,Ltd. assumes no responsibility for equipment failures that result from using products at values that exceed, even momentarily, rated values (such as maximum ratings, operating condition ranges, or other parameters) listed in products specifications of any and all SANYO Semiconductor Co.,Ltd. products described or contained herein.
- SANYO Semiconductor Co.,Ltd. strives to supply high-quality high-reliability products, however, any and all semiconductor products fail or malfunction with some probability. It is possible that these probabilistic failures or malfunction could give rise to accidents or events that could endanger human lives, trouble that could give rise to smoke or fire, or accidents that could cause damage to other property. When designing equipment, adopt safety measures so that these kinds of accidents or events cannot occur. Such measures include but are not limited to protective circuits and error prevention circuits for safe design, redundant design, and structural design.
- In the event that any or all SANYO Semiconductor Co.,Ltd. products described or contained herein are controlled under any of applicable local export control laws and regulations, such products may require the export license from the authorities concerned in accordance with the above law.
- No part of this publication may be reproduced or transmitted in any form or by any means, electronic or mechanical, including photocopying and recording, or any information storage or retrieval system, or otherwise, without the prior written consent of SANYO Semiconductor Co.,Ltd.
- Any and all information described or contained herein are subject to change without notice due to product/technology improvement, etc. When designing equipment, refer to the "Delivery Specification" for the SANYO Semiconductor Co.,Ltd. product that you intend to use.
- Information (including circuit diagrams and circuit parameters) herein is for example only; it is not guaranteed for volume production.
- Upon using the technical information or products described herein, neither warranty nor license shall be granted with regard to intellectual property rights or any other rights of SANYO Semiconductor Co.,Ltd. or any third party. SANYO Semiconductor Co.,Ltd. shall not be liable for any claim or suits with regard to a third party's intellectual property rights which has resulted from the use of the technical information and products mentioned above.

This catalog provides information as of April, 2011. Specifications and information herein are subject to change without notice.