



LC89201

9600-bps Facsimile Modem

Preliminary

Overview

The LC89201 is a CMOS single-chip, synchronous, half-duplex, 9600-bps fax modem designed for use with public telephone networks. Built in are such essential features for Group III facsimile systems as modulator, demodulator, transmission filters, and V.24 interface.

The LSI supports the V.29, V.27ter, V.21ch2, T.30, and T.4 telecommunications standards promulgated by the ITU-T (formerly the CCITT) for transmission at 9600, 7200, 4800, 2400 and 300 bps. Advanced signal processing provides reliable data transmissions even under adverse circuit conditions. Built-in High-level Data Link Control (HDLC) support permits the construction of Error Correction Mode (ECM) facsimile machines.

Features

- Support for the following ITU-T standards: V.29 (9600, 7200 and 4800 bps), V.27ter (4800 and 2400 bps), V.21ch2 (300 bps), T.30, and T.4.
- Half-duplex operation.
- Group III facsimile support.
- Automatic switching between high- (V.29 and V.27ter) and low-speed (V.21ch2) incoming facsimiles.
- Short training (for ITU-T V.27ter only).
- HDLC framing and deframing (V.29, V.27ter, and V.21ch2).
- Tone generation and detection.
- Dual-tone multifrequency (DTMF) generation and detection.
- Call progress tone detection.
- Pseudo link back tone generation.
- Built-in automatic adaptive equalizer.
- Built-in fixed-amplitude amplifier.
 - Link amplitude equalizer
 - Cable amplitude equalizer
- Built-in transmission filters (digital filters).
- Programmable transmission level adjustment.
- Dynamic range for reception of 0 to -47 dBm.
- Programmable reception sensitivity adjustment.
- DTE interface.
 - Serial interface (ITU-T V.24)
 - Parallel interface (4 words × 8 bits, with built-in FIFO)
- Programmable interrupt generator.

- Built-in eye pattern generator.
- Adaptive differential pulse-code modulation (ADPCM).
- Caller ID detection.
- Built-in diagnostics.
- Energy-saving CMOS design (typ. 250 mW).
- Single 5 V power supply.
- 80-pin flat package (QIP-80E).

Package Dimensions

unit: mm

3174-QFP80E

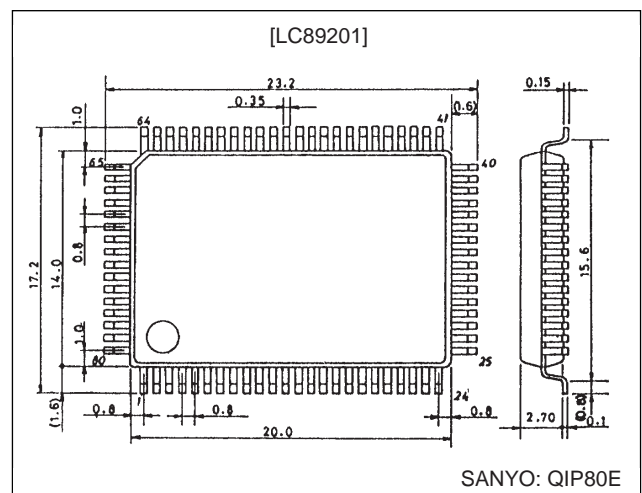

LC89201

System Block Diagram

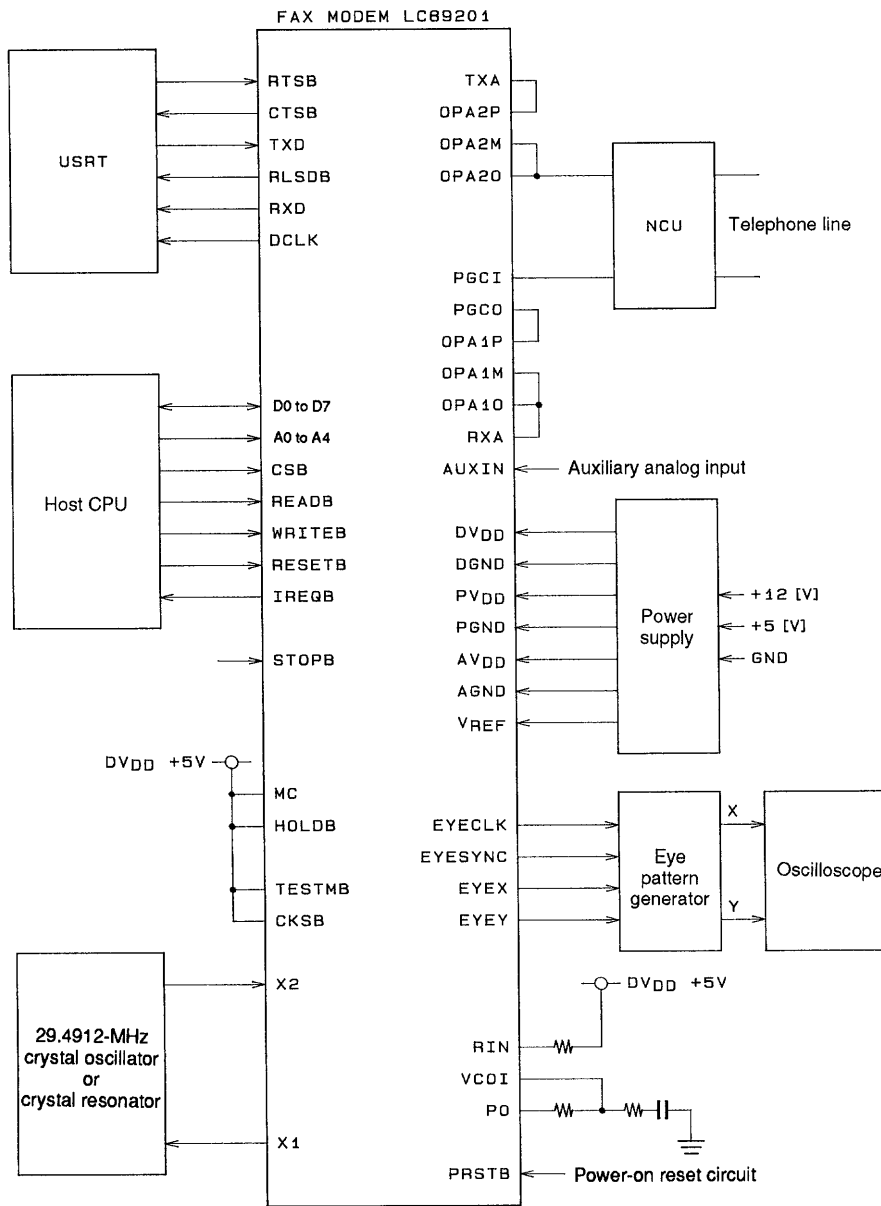

A03067

Internal Block Diagram

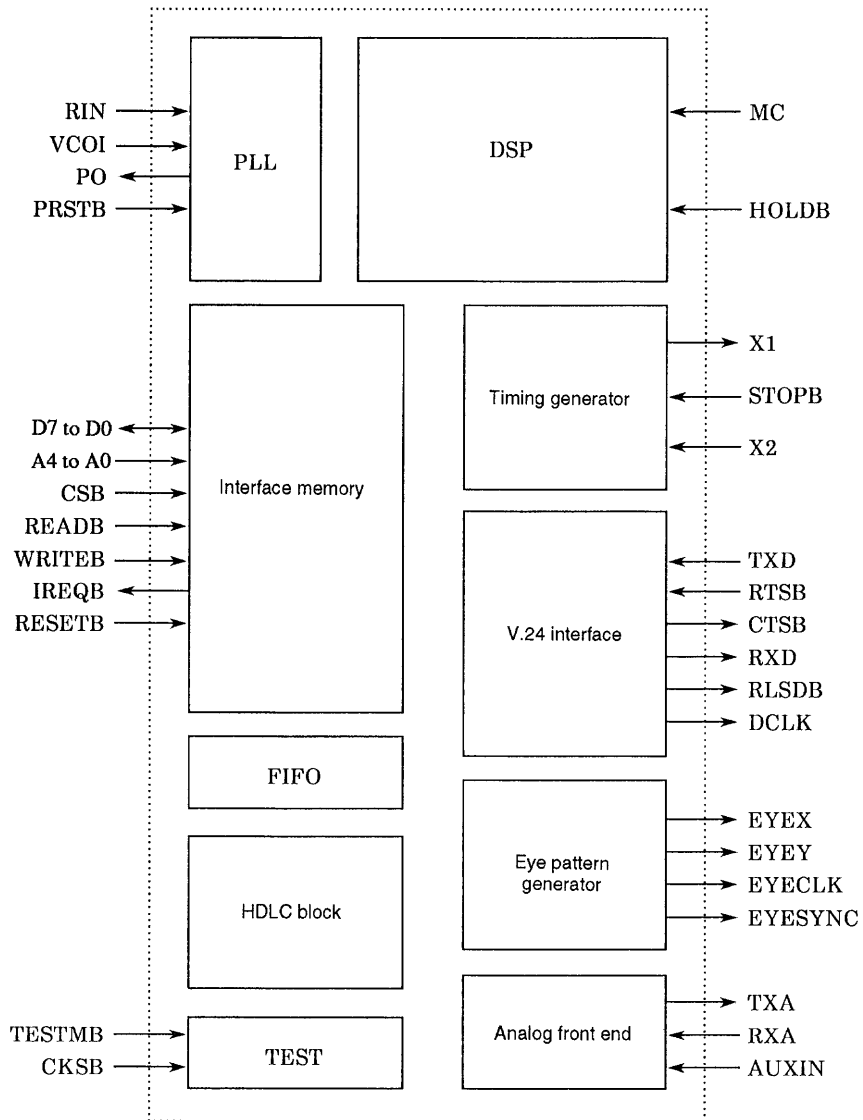

LC89201

Pin Assignment

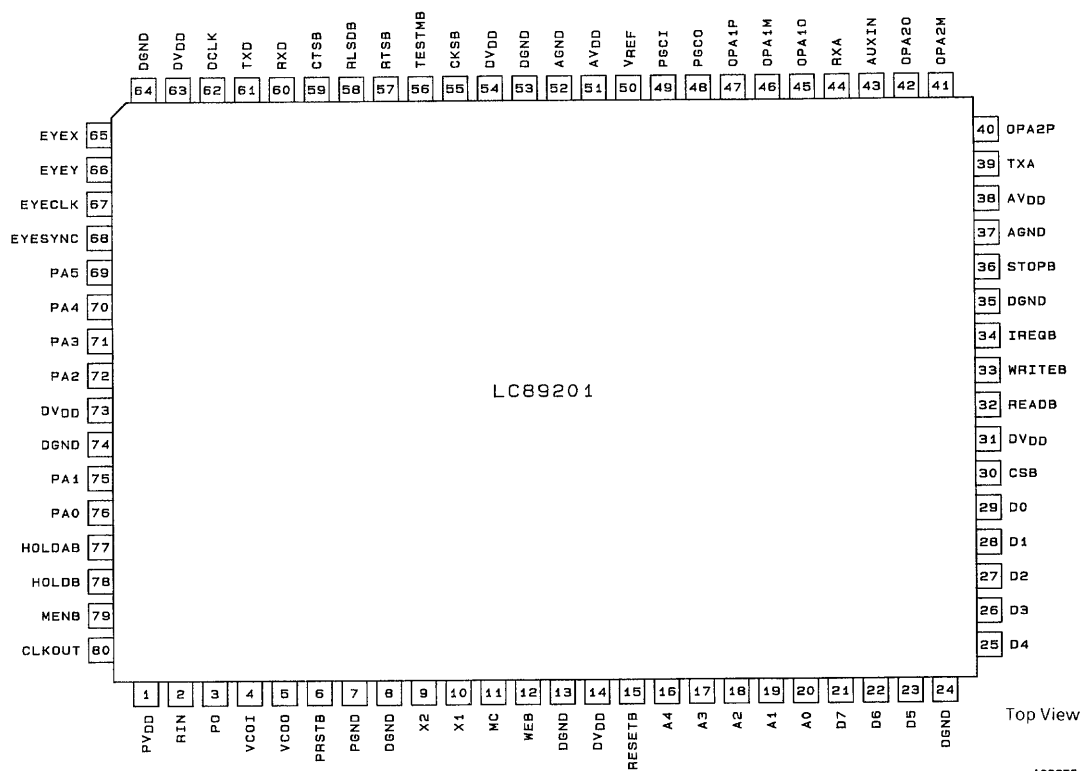

Pin Functions

1. Power Supply, Clock and Test Pins

Pin No.	Symbol	I/O	Function
14 31 54 63 73	DV _{DD}	P	Digital power supply
8 13 24 35 53 64 74	DGND	P	Digital ground
38 51	AV _{DD}	P	Analog power supply
37 52	AGND	P	Analog ground
1	PV _{DD}	P	Frequency multiplier PLL power supply
7	PGND	P	Frequency multiplier PLL ground
50	V _{REF}	P	Reference power supply. This must be half AV _{DD} .
9	X2	I	System clock input (29.4912 MHz)
10	X1	O	Oscillator amplifier output
80	CLKOUT	O	Output clock, one-quarter the frequency of the internal master clock (9.216 MHz).
56	TESTMB	I	Test pin. Connect to DV _{DD} .
55	CKSB	I	Test pin. Connect to DV _{DD} .

LC89201

2. DTE Interface Pins

Pin No.	Symbol	I/O	Function
29	D0	B	Data bus to host CPU
28	D1		
27	D2		
26	D3		
25	D4		
23	D5		
22	D6		
21	D7		
20	A0	I	Address bus to host CPU
19	A1		
18	A2		
17	A3		
16	A4		
30	CSB	I	Chip select signal
32	READB	I	Interface memory read signal
33	WRITEB	I	Interface memory write signal
34	IREQB	O	Interrupt request to host CPU
15	RESETB	I	System reset signal

3. Eye Pattern Interface Pins

Pin No.	Symbol	I/O	Function
67	EYECLK	O	Timing clock for generating eye pattern data. This may be used as the shift clock for an external shift register.
68	EYESYNC	O	Eye pattern synchronization signal
66	EYEX	O	Eye pattern data serial outputs (8 bits, MSB first)
65	EYEW		

4. V.24 (RS-232C) Interface Pins

Pin No.	Symbol	I/O	Function
57	RTSB	I	Request to send signal. The low level at this pin starts transmission; the high level suspends it.
59	CTSB	O	Clear to send signal. The low level at this pin signals the availability of data for transmission; the high level indicates that the data is invalid.
58	RLSDB	O	Received line signal data signal. The low level at this pin gives the timing for transferring the data received to the terminal.
61	TXD	I	Transmit data input
60	RXD	O	Receive data output
62	DCLK	O	Transmission data clock output

5. Analog Signal Pins

Pin No.	Symbol	I/O	Function
39	TXA	O	Transmitter analog output
44	RXA	I	Receiver analog input
43	AUXIN	I	Auxiliary analog input
40	OPA2P	I	Transmission buffer input/output pins. (For details, see circuit diagram.)
41	OPA2M	I	
42	OPA2O	O	
47	OPA1P	I	Reception buffer input/output pins (For details, see circuit diagram.)
46	OPA1M	I	
45	OPA1O	O	
49	PGCI	I	Reception gain adjustment circuit input. (For details, see circuit diagram.)
48	PGCO	O	Reception gain adjustment circuit output.

LC89201

6. System signal pins

Pin No.	Symbol	I/O	Function
11	MC	I	Program mode control signal. Connect to DV _{DD} .
78	HOLDB	I	System hold signal. Connect to DV _{DD} .
77	HOLDAB	O	System hold confirmation signal.
6	PRTSB	I	Frequency multiplier PLL reset input. (For details, see circuit diagram.)
3	PO	O	Phase comparator output. (For details, see circuit diagram.)
4	VCOI	I	Voltage-controlled oscillator input. (For details, see circuit diagram.)
5	VCOO	O	Voltage-controlled oscillator output
2	RIN	I	Voltage-controlled oscillator adjustment input. (For details, see circuit diagram.)
36	STOPB	I	Oscillator amplifier STOP input

Note: All other pins are to be left unconnected.

Specifications

Absolute Maximum Ratings at DGND, AGND, PGND = 0 V

Parameter	Symbol	Conditions	Ratings	Unit
Maximum supply voltage	DV _{DD} max	Ta = 25°C	-0.3 to +7.0	V
	AV _{DD} max	Ta = 25°C	-0.3 to +7.0	V
	PV _{DD} max	Ta = 25°C	-0.3 to +7.0	V
I/O voltages	V _I V _O	Ta = 25°C	-0.3 to V _{DD} + 0.3	V
Allowable power dissipation	Pd max	Ta ≤ 70°C	400	mW
Operating temperature	T _{opr}		-30 to +70	°C
Storage temperature	T _{stg}		-55 to +125	°C
Soldering heat resistance		Hand soldering (3 seconds)	350	°C
		Reflow (10 seconds)	235	°C

Allowable Operating Ranges at Ta = -30 to +70°C, DGND, AGND, PGND = 0 V

Parameter	Symbol	Conditions	min	typ	max	Unit
Supply voltage	DV _{DD}		4.5	5.0	5.5	V
	AV _{DD}		4.5	5.0	5.5	V
	PV _{DD}		4.5	5.0	5.5	V
Input voltage	V _{IN}		0		V _{DD}	V

LC89201

Electrical Characteristics at Ta = -30 to +70°C, DGND, AGND, PGND = 0 V, DV_{DD}, AV_{DD}, PV_{DD} = 4.5 to 5.5 V

Parameter	Symbol	Conditions	min	typ	max	Unit
Input high level voltage	V _{IH}	TTL levels: RESETB, PRSTB, STOPB, A0 to A4, D0 to D7, CSB, READB, WRITEB, RTSB, TXD, HOLDB, MC, TESTMB, CKSB	2.2			V
Input low level voltage	V _{IL}				0.8	V
Input leak current	I _L	V _{IN} = DGND, AGND, PGND, DV _{DD} , AV _{DD} , PV _{DD} ; RESETB, PRSTB, STOPB, A0 to A4, D0 to D7, CSB, READB, WRITEB, RTSB, TXD, HOLDB, MC, TESTMB, CKSB	-1		+1	μA
Output high level voltage	V _{OH}	I _{OH} = -3 mA, TTL levels: WEB, MENB, CLKOUT, HOLDAB, PA0 to PA5, D0 to D7, IREQB, CTSB, RLSDB, RXD, DCLK, VCOO, EYEX, EYEV, EYECLK, EYESYNC	2.4			V
Output low level voltage	V _{OL}	I _{OL} = 3 mA, TTL levels: WEB, MENB, CLKOUT, HOLDAB, PA0 to PA5, D0 to D7, IREQB, CTSB, RLSDB, RXD, DCLK, VCOO, EYEX, EYEV, EYECLK, EYESYNC			0.4	V
Output leak current	I _{OZ}	For high-impedance output: D0 to D7	-10	+10		μA
Oscillator frequency	f _{OSC}	X2, X1		29.4912		MHz
V _{REF} input voltage	V _{REF}	V _{REF}		V _{DD} /2		V
V _{REF} impedance	R _{REF}	V _{REF}	1			MΩ
Input voltage range	V _{IA}	RIN, VCOI, OPA1M, OPA1P, RAX, OPA2M, OPA2P, PGCI	V _{DD} *0.2		V _{DD} *0.8	V
Output voltage range	V _{OA}	TXA, PGCO, OPA1O, OPA2O	V _{DD} *0.2		V _{DD} *0.8	V
Output impedance	R _O	TXA, PGCO, OPA1O, OPA2O			7	kΩ
Current drain	I _{DD}	V _{DD} = 5.5 V			80	mA
		V _{DD} = 5.0 V		50		mA

AC Characteristics

1. DTE interface timing

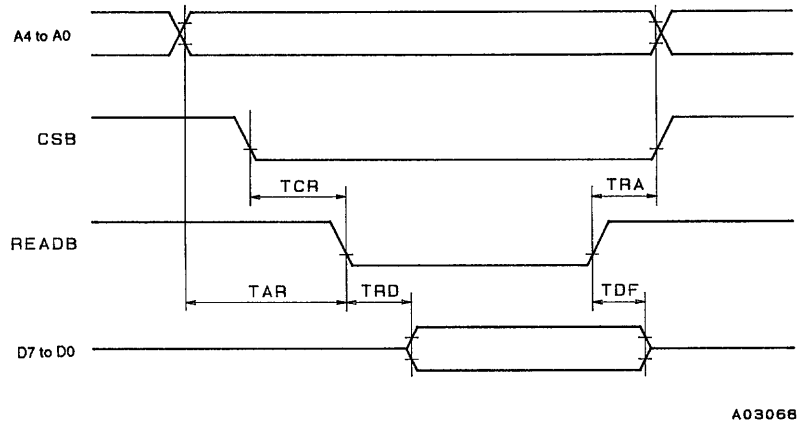

Read cycle timing

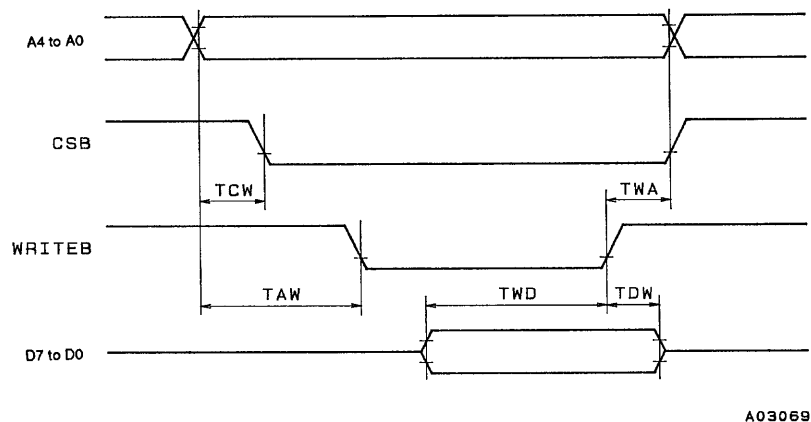

LC89201

Parameter	Symbol	Conditions	min	typ	max	Unit
Address stabilization time (relative to READB signal)	TAR		15			ns
Chip select stabilization time (relative to READB signal)	TCR		0			ns
Data propagation delay	TRD				30	ns
Data float propagation delay	TDF		10			ns
Address hold time (relative to READB signal)	TRA		10			ns
Address stabilization time (relative to WRITEB signal)	TAW		15			ns
Chip select stabilization time (relative to WRITEB signal)	TCW		0			ns
Data setup time	TDW		20			ns
Data hold time	TWD		5			ns
Address hold time (relative to WRITEB signal)	TWA		10			ns

2. Reset timing

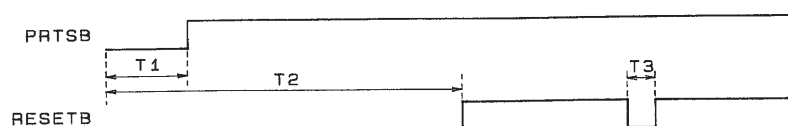

A03070

Parameter	Symbol	Conditions	min	typ	max	Unit
PRTSB pulse width	T1		500			μs
PRTSB propagation delay relative to RESETB	T2		5			ms
RESETB pulse width	T3		500			ns

- No products described or contained herein are intended for use in surgical implants, life-support systems, aerospace equipment, nuclear power control systems, vehicles, disaster/crime-prevention equipment and the like, the failure of which may directly or indirectly cause injury, death or property loss.
- Anyone purchasing any products described or contained herein for an above-mentioned use shall:
 - ① Accept full responsibility and indemnify and defend SANYO ELECTRIC CO., LTD., its affiliates, subsidiaries and distributors and all their officers and employees, jointly and severally, against any and all claims and litigation and all damages, cost and expenses associated with such use:
 - ② Not impose any responsibility for any fault or negligence which may be cited in any such claim or litigation on SANYO ELECTRIC CO., LTD., its affiliates, subsidiaries and distributors or any of their officers and employees jointly or severally.
- Information (including circuit diagrams and circuit parameters) herein is for example only; it is not guaranteed for volume production. SANYO believes information herein is accurate and reliable, but no guarantees are made or implied regarding its use or any infringements of intellectual property rights or other rights of third parties.

This catalog provides information as of September, 1995. Specifications and information herein are subject to change without notice.

Caption

P.7/8

P.2

A4 to A0
D7 to D0
A4 to A0
D7 to D0

1. Host CPU
2. 29.4912-MHz
crystal oscillator
or
crystal resonator
3. Telephone line
4. Power
supply
5. Auxiliary analog input
6. Eye
pattern
generator
7. Oscilloscope
8. Power-on reset circuit

P.3

1. Interface memory
2. Timing generator
3. V.24 interface
4. Eye pattern
generator
5. HDLC block
6. Analog front end

New P2/8

2. 29.4912-MHz
crystal oscillator
or
crystal resonator
8. Power-on reset circuit

D0 to D7

A0 to A4

P3/8

D7 to D0

A4 to A0