



LC895297

Full CAV 20× CD-ROM Decoder with Built-in ATA-PI (IDE) Interface and CD-DSP

Preliminary

Overview

The LC895297 is a single-chip CD-ROM decoder and CD-DSP system that supports full CAV 20× operation and includes a built-in ATA-PI (IDE) interface.

Functions

- Full CAV 20× CD-DSP and CD-ROM decoder functions with built-in ATA-PI (IDE) interface

Features

[CD-ROM Decoder and ATA-PI (IDE) Interface Blocks]

- Full CAV 20× operation
- ATA-PI (IDE) interface
- Supports the use of EDO DRAM.
- Supports the use of up to 4 Mbits of buffer RAM.
- The user can set up arbitrary CD main channel and C2 flag areas in buffer RAM.
- Batch transfer function (function that automatically transfers the CD main channel and C2 flag data in a single operation.)
- Multi-block transfer function (function that automatically transfers multiple blocks in a single operation.)
- DVD ECC interface
- Intelligent functions

[CD-DSP Block]

- The IC inputs a high-frequency signal, slices that signal at the correct level, converts that result to an EFM coded signal, and compares the phase with that of the built-in VCO.
- Uses an external 16.9344-MHz crystal element to generate a standard clock and to correctly generate the required internal timings.
- Performs frame synchronization, signal detection, protection, and insertion, and assures stable data readout.
- Demodulates the EFM coded signal to produce 8-bit symbol data.
- After applying a CRC check to the subcode Q signal, outputs that signal to a microprocessor over a parallel

I/O channel.

- Performs unscrambling and de-interleaving to reorder the demodulated EFM signal in the prescribed manner.
- Performs error code detection and correction, and flag processing. (C1: dual errors, C2: four errors)
- Sets the C2 flags based on the C1 flags and a C2 check, and performs interpolation or muting depending on the C2 flags. Adopts a 2-point interpolation circuit, and converges the signal to the muting level if the C2 flags indicate over 2 consecutive uncorrectable errors.
- Accepts the input of commands from a control microprocessor over an 8-bit parallel interface. Supports track jump, disc motor start/stop, muting on/off, and track counting commands.
- Can perform arbitrary track counts.
- Includes CAV audio functions.
- Adopts zero-cross muting.
- Includes 8× oversampling digital filters.
- D/A converter with PWM output.
- Includes independent left and right channel digital attenuators.
- Provides digital deemphasis.
- Supports bilingual functions.

Package Dimensions

unit: mm

3230-SQFP176

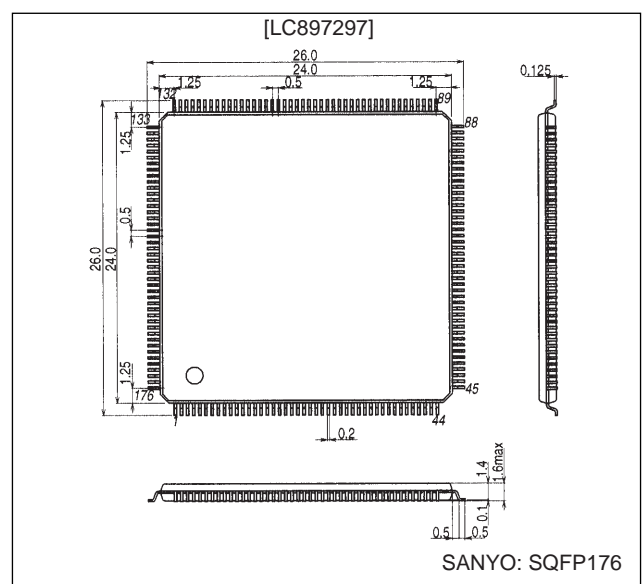

Specifications

Absolute Maximum Ratings at $T_a = 25^\circ\text{C}$, $V_{SS} = 0\text{ V}$

Parameter	Symbol	Conditions	Ratings	Unit
Maximum supply voltage	$V_{DD\text{ max}}$		-0.3 to +7.0	V
Input and output voltage	V_I, V_O		-0.3 to $V_{DD}+0.3$	V
Allowable power dissipation	$P_d\text{ max}$	$T_a \leq 70^\circ\text{C}^*1$	500	mW
Operating temperature	T_{opr}		-30 to +70	$^\circ\text{C}$
Storage temperature	T_{stg}		-55 to +125	$^\circ\text{C}$
Soldering conditions (pins only)		10s	235	$^\circ\text{C}$
Input and output current	I_I, I_O	Per individual input or output cell	± 20	mA

Note 1: Applications that use this IC must adopt heat dissipation measures, such as the insertion of a thermally conductive sheet.

Allowable Operating Ranges at $T_a = -30$ to $+70^\circ\text{C}$, $V_{SS} = 0\text{ V}$

Parameter	Symbol	Conditions	Ratings			Unit
			min	typ	max	
[Input and Output Cell Power Supply]						
Supply voltage	V_{DD}		4.5	5.0	5.5	V
Input voltage range	V_{IN}		0		V_{DD}	V
[Internal Cell Power Supply]						
Supply voltage	V_{DD}		3.9	4.0	4.1	V
Input voltage range	V_{IN}		0		V_{DD}	V

Electrical Characteristics at $T_a = -30$ to $+70^\circ\text{C}$, $V_{SS} = 0\text{ V}$, $V_{DD} = 4.5$ to 5.5 V

Parameter	Symbol	Conditions	Ratings			Unit
			min	typ	max	
Input high-level voltage	V_{IH}	TTL levels. Applicable pins: (10) and (13)	2.2			V
Input low-level voltage	V_{IL}				0.8	V
Input high-level voltage	V_{IH}	TTL levels. Applicable pins: (1)	2.2			V
Input low-level voltage	V_{IL}	Pull-up resistor included.			0.8	V
Input high-level voltage	V_{IH}	TTL levels. Applicable pins: (2), (3), and (15)	2.4			V
Input low-level voltage	V_{IL}	Schmitt inputs.			0.8	V
Input high-level voltage	V_{IH}	CMOS levels: Applicable pins: (14)	$0.7 V_{DD}$			V
Input low-level voltage	V_{IL}				$0.3 V_{DD}$	V
Input high-level voltage	V_{IH}	CMOS levels: Applicable pins: (4)	$0.8 V_{DD}$			V
Input low-level voltage	V_{IL}	Schmitt inputs.			$0.2 V_{DD}$	V
Output high-level voltage	V_{OH}	$I_{OH} = -2\text{ mA}$: Applicable pins: (5), (1), (9), (10), and (15)	$V_{DD} - 2.1$			V
Output low-level voltage	V_{OL}	$I_{OL} = 2\text{ mA}$: Applicable pins: (5), (1), (9), (10), and (15)			0.4	V
Output high-level voltage	V_{OH}	$I_{OH} = -4\text{ mA}$: Applicable pins: (3) and (6)	$V_{DD} - 2.1$			V
Output low-level voltage	V_{OL}	$I_{OL} = 24\text{ mA}$: Applicable pins: (3) and (6)			0.4	V
Output low-level voltage	V_{OL}	$I_{OL} = 2\text{ mA}$: Applicable pins: (7) and (11)			0.4	V
Output low-level voltage	V_{OL}	$I_{OL} = 24\text{ mA}$: Applicable pins: (12)			0.4	V
Input leakage current	I_{IL}	$V_I = V_{SS}$, V_{DD} : Applicable pins: (2), (3), (4), (10), and (15)	-10		+10	μA
Output leakage current	I_{OZ}	In high-impedance output mode: Applicable pins: (3), (6), (7), (9), (10), (12), and (15)	-10		+10	μA
Pull-up resistance	R_{UP}	Applicable pins: (1) and (11)	40	80	160	k Ω

The applicable pin sets are as follows:

[INPUT]

(2) ZRESET, ZDMACK, ZHRST, DA0to DA2, ZCS1FX, ZCS3FX, ZDIOR, ZDIOW, FG

(4) ZCSCtrl, ZCS, ZRD, ZWR, HFL, TES

(14) DEF1

(13) SUA0 o SUA6

[OUTPUT]

(6) DMARQ, HINTRQ

(5) RA0 to RA8, ZRAS0, ZCAS0, ZOE, ZUWE, ZLWE, C2F, ROMXA, FSX, EFLG, PCK, FSEQ, TOFF, TGL, 4.2M, WRQ, RWC, COIN, ZCQCK, RCHP, RCHN, LCHP, LCHN

(7) ZRSTCPU, ZRSTIC

(9) JP+, JP-, SPO

(11) ZINT0, ZINT1, ZSWAIT

(12) IORDY, ZIOCS16

Continued on next page.

Continued from preceding page.

[INOUT]

- (1) D0 to D7, IO0 to IO15
- (3) DD0 to DD15, ZDASP, ZPDIAG
- (10) IOP0 to IOP7
- (15) DRESP, DREQ

Note: XTAL, XTALCK, R0, VCNT0, PDO0, R1, VCNT1, PO11, PO21, BSN1, R2, VCNT2, PO12, PO22, and BSN2
 The above pins are not covered by the electrical characteristics.
 The 1-bit D/A converter block pins are only measured using a logic tester; no analog measurements are performed.

EFM Input and Output Signals

Electrical Characteristics at Ta = -30 to +70°C, VSS = 0 V, VDD = 4.5 to 5.5 V

Parameter	Symbol	Conditions	Ratings			Unit
			min	typ	max	
Input high-level voltage	V _{IH}	Micro-signal amplifier. Applicable pins: EFMI	3.2			V
Input low-level voltage	V _{IL}				1.8	V
Output high-level voltage	V _{OH}	I _{OH} = -4 mA. Applicable pins: EFMO and ZEFMO	V _{DD} - 2.1			V
Output low-level voltage	V _{OL}	I _{OL} = 4 mA. Applicable pins: EFMO and ZEFMO			0.4	V
Input leakage current	I _{IL}	V _I = V _{SS} , V _{DD} : Applicable pins: EFMI	-10		+10	µA
Output leakage current	I _{oz}	In high-impedance mode: Applicable pins: EFMO and ZEFMO	-10		+10	µA

External Clock Generator PLL Circuit

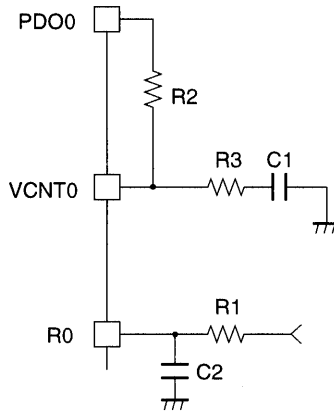

A09481

Figure 1 PLL Circuit

Symbol	Currently used value	Notes
R1	7.5 kΩ	VCO adjustment resistor
R2	10 kΩ	Low-pass filter resistor
R3	200 Ω	Low-pass filter phase compensation resistor
C1	0.1 µF	Low-pass filter capacitor
C2	0.1 µF	VCO bias stabilization capacitor

While the circuit structure is fixed, the values of the components will vary with the circuit board capacitance and other application circuit parameters.

Block Diagram

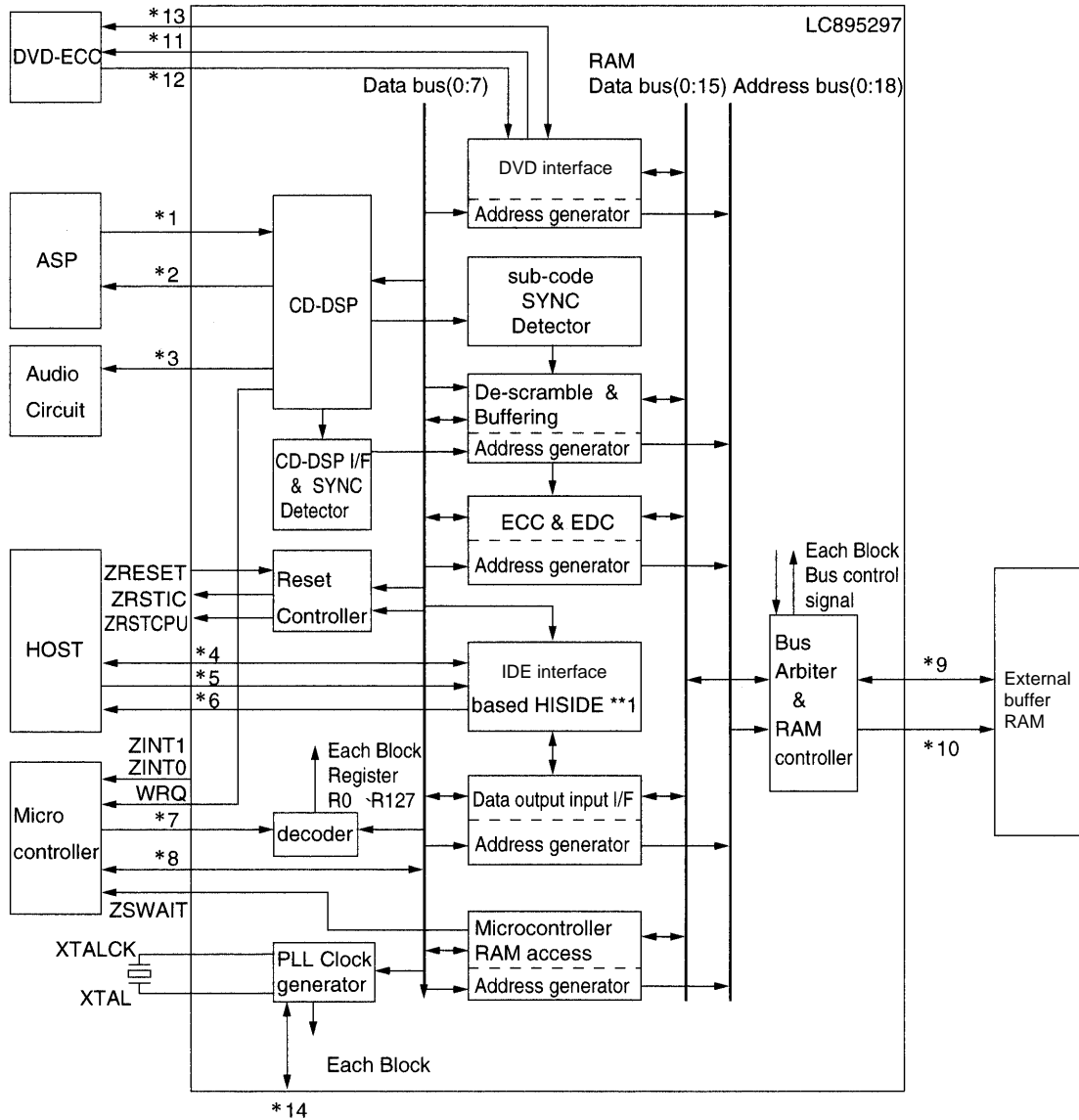

A09482

- *1 DEF1, EFMI, HFL, TES
- *2 4.2M, EFMO, PCK, FSEQ, TOFF, TGL, JP⁺, JP⁻, RWC, COIN, ZCQCK
- *3 RCHP, RCHN, LCHP, LCHN
- *4 DD0 to DD15, ZDASP, ZPDIAG
- *5 ZCS1FX, ZCS3FX, DA0 to DA2, ZDIOR, ZDIOW, ZDMACK, ZHRST
- *6 DMARQ, HINTRQ, ZIOCS16, IORDY
- *7 ZRD, ZWR, ZCS, ZCCTRL, SUA0 to SUA6
- *8 D0 to D7
- *9 IO0 to IO15
- *10 RA0 to RA8, ZRAS0, ZCAS0, ZOE, ZUWE, ZLWE
- *11 DREQ
- *12 DRESP
- *13 IOP0 to IOP7
- *14 R0, VCNT0, PDO0
- **1 HISIDE (WD25C32) is made by WESTERN DIGITAL

LC895297

Pin Functions

I : Input pin, O: Output pin, B : Bidirectional pin, P: Power supply pin, NC: Not connected

Pin No.	Pin name	Type	Function
1	AV _{SS0}	P	
2	R0	I	VCO bias resistor connection
3	VCNT0	I	VCO control voltage input
4	PDO0	O	Charge pump output
5	TEST0	I	Test pins
6	TEST1	I	
7	IOP0 (HDB7)	B	General-purpose I/O ports These pins are used for DVD ECC data input when the DVD interface is used.
8	IOP1 (HDB6)	B	
9	IOP2 (HDB5)	B	
10	IOP3 (HDB4)	B	
11	IOP4 (HDB3)	B	
12	IOP5 (HDB2)	B	
13	IOP6 (HDB1)	B	
14	IOP7 (HDB0)	B	
15	V _{DD2}	P	4.0 V
16	TEST3	I	Test pin
17	TEST4	I	Test pin
18	DRESP	I	DVD ECC data latch signal input
19	DREQ	O	DVD ECC data request output
20	RCHP	O	1-bit D/A converter right channel P output
21	RCHN	O	1-bit D/A converter right channel N output
22	V _{DD1}	P	1-bit D/A converter left and right channel power supply
23	V _{SS1}	P	1-bit D/A converter right channel ground
24	LCHP	O	1-bit D/A converter left channel P output
25	LCHN	O	1-bit D/A converter left channel N output
26	V _{SS0}	P	
27	XTALCK	I	Crystal oscillator circuit input (16.9344 MHz)
28	XTAL	O	Crystal oscillator circuit output
29	V _{SS0}	P	
30		NC	
31	ZRSTCPU	O	CPU reset signal output
32	ZRSTIC	O	Drive IC reset signal output
33	ZRESET	I	IC reset input
34	D7	B	Microcontroller data signal connection. These pins include built-in pull-up resistors.
35	D6	B	
36	D5	B	
37	D4	B	
38	D3	B	
39	D2	B	
40	D1	B	
41	D0	B	

Continued on next page.

LC895297

Continued from preceding page.

I : Input pin, O: Output pin, B : Bidirectional pin, P: Power supply pin, NC: Not connected

Pin No.	Pin name	Type	Function
42	SUA0	I	Microcontroller register selection
43	SUA1	I	
44	V _{DD0}	P	5 V
45	V _{SS0}	P	
46	V _{DD2}	P	4.0 V
47	SUA2	I	Microcontroller register selection
48	SUA3	I	
49	SUA4	I	
50	SUA5	I	
51	SUA6	I	
52	ZCCTRL	I	Microcontroller chip select active-low/high selection
53	ZCS	I	Register chip select signal input (from the microcontroller)
54	ZSWAIT	O	Wait signal output (to the microcontroller)
55	ZWR	I	Data write signal input (from the microcontroller)
56	ZRD	I	Data read signal input (from the microcontroller)
57	ZINT0	O	Interrupt request signal output (to the microcontroller)
58	ZINT1	O	
59	WRQ	O	Subcode Q output standby output
60	FSEQ	O	Synchronization signal detection output
61	C2F	O	C2 flag output for ROMXA
62	ROMXA	O	Interpolation data output for ROMXA
63	FSX (CK2)	O	7.35-kHz signal output (Bit clock output for ROMXA)
64	EFLG (LRSY)	O	C1 and C2 error correction monitor output (LRSY output for ROMXA)
65	FG	I	FG pulse input for CAV control
66	V _{DD2}	P	4.0 V
67	V _{SS0}	P	
68	TEST2	I	Test pin
69	ZEFMO	O	Inverted EFM signal output
70	EFMO	O	EFM signal output
71	EFMI	I	EFM signal input
72	V _{DD0}	P	5 V
73	JP-	O	Track jump output
74	JP+	O	
75	TGL	O	Tracking gain switching output
76	TOFF	O	Tracking off output
77	TES	I	Tracking error signal input. Schmitt input
78	HFL	I	Tracking detection signal input. Schmitt input
79	NC		
80	SPO	O	CAV control output
81	DEFI	I	Defect detection signal input
82	4.2M	O	4.2336-MHz output
83	R1	I	VCO bias resistor connection
84	BSN1	I	Charge pump bias resistor connection
85	VCNT1	I	VCO control voltage
86	PO11	O	Charge pump outputs
87	PO21	O	
88	AV _{DD1}	P	4.0 V
89	AV _{SS1}	P	

Continued on next page.

LC895297

Continued from preceding page.

I : Input pin, O: Output pin, B : Bidirectional pin, P: Power supply pin, NC: Not connected

Pin No.	Pin name	Type	Function
90	R2	I	VCO bias resistor connection
91	BSN2	I	Charge pump bias resistor connection
92	VCNT2	I	VCO control voltage
93	PO12	O	Charge pump outputs
94	PO22	O	
95	V _{DD2}	P	4.0 V
96	PCK	O	EFM data reproduction bit clock monitor
97		NC	
98	ZCQCK	O	ASP command acquisition clock output
99	COIN	O	ASP command output
100	RWC	O	Output to the ASP read/write control input
101	ZRAS0	O	Buffer RAM RAS signal output
102	ZCAS0	O	Buffer RAM CAS signal output
103	ZOE	O	Buffer RAM output enable
104	V _{SS0}	P	
105	ZUWE	O	Buffer RAM upper write enable
106	ZLWE	O	Buffer RAM lower write enable
107	RA0	O	Data buffer RAM address signal outputs
108	RA1	O	
109	RA2	O	
110	V _{DD0}	P	5 V
111	V _{SS0}	O	
112	RA3	O	Data buffer RAM address signal outputs
113	RA4	O	
114	RA5	O	
115	RA6	O	
116	RA7	O	
117	RA8	O	
118	IO8	B	Data buffer RAM data input and output These pins include built-in pull-up resistors.
119	IO9	B	
120	IO10	B	
121	V _{SS0}	P	
122	IO11	B	Data buffer RAM data input and output These pins include built-in pull-up resistors.
123	IO12	B	
124	IO13	B	
125	IO14	B	
126	IO15	B	
127	IO7	B	
128	IO6	B	
129	IO5	B	
130	IO4	B	
131	IO3	B	
132	V _{DD2}	P	4.0 V
133	V _{SS0}	P	
134	IO2	B	Data buffer RAM data input and output These pins include built-in pull-up resistors.
135	IO1	B	
136	IO0	B	

Continued on next page.

LC895297

Continued from preceding page.

I : Input pin, O: Output pin, B : Bidirectional pin, P: Power supply pin, NC: Not connected

Pin No.	Pin name	Type	Function
137	ZHRST	I	ATAPI control signal
138	V _{SS2}	P	
139	DD7	B	ATAPI data bus
140	DD8	B	
141	DD6	B	
142	DD9	B	
143	V _{DD0}	P	
144	V _{SS2}	P	
145	DD5	B	ATAPI data bus
146	DD10	B	
147	DD4	B	
148	DD11	B	
149	V _{SS2}	P	
150	DD3	B	ATAPI data bus
151	DD12	B	
152	DD2	B	
153	DD13	B	
154	V _{DD0}	P	
155	V _{SS2}	P	
156	DD1	B	ATAPI data bus
157	DD14	B	
158	DD0	B	
159	DD15	B	
160	V _{SS2}	P	
161	DMARQ	O	ATAPI control signal
162	ZDIOW	I	
163	ZDIOR	I	
164	IORDY	O	
165	ZDMACK	I	
166	HINTRQ	O	
167	ZIOCS16	O	
168	V _{SS2}	P	
169	DA1	I	ATAPI control signal
170	ZPDIAG	B	
171	DA0	I	
172	DA2	I	
173	ZCS1FX	I	
174	ZCS3FX	I	
175	ZDASP	B	
176	AV _{DD0}	P	

Pin names that start with the letter Z are negative-logic signals.

The following power-supply voltages must be provided; V_{DD0}: 5 V, V_{DD1} (for the 1-bit D/A converter): 5 V, and V_{DD2}: 4.0 V.

V_{SS0} is the logic system ground, V_{SS1} is the 1-bit D/A converter ground, and V_{SS2} is the IDE interface drive ground.

Thermal Design

Since this IC supports operation at up to 20× speeds, it operates at extremely high speeds internally. Applications must take measures to dissipate the heat that results from this high-speed operation. IC operation is not guaranteed if adequate heat dissipation measures are not taken.

Heat Dissipation Example

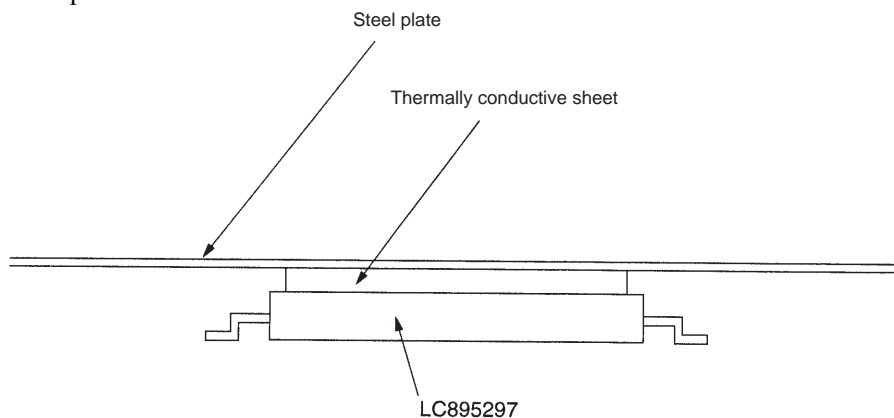

A09483

Applications must be designed with a thermally conductive sheet above the LC895297 and the LC895297 positioned so that the system chassis contacts the thermally conductive sheet.

- No products described or contained herein are intended for use in surgical implants, life-support systems, aerospace equipment, nuclear power control systems, vehicles, disaster/crime-prevention equipment and the like, the failure of which may directly or indirectly cause injury, death or property loss.
- Anyone purchasing any products described or contained herein for an above-mentioned use shall:
 - ① Accept full responsibility and indemnify and defend SANYO ELECTRIC CO., LTD., its affiliates, subsidiaries and distributors and all their officers and employees, jointly and severally, against any and all claims and litigation and all damages, cost and expenses associated with such use:
 - ② Not impose any responsibility for any fault or negligence which may be cited in any such claim or litigation on SANYO ELECTRIC CO., LTD., its affiliates, subsidiaries and distributors or any of their officers and employees jointly or severally.
- Information (including circuit diagrams and circuit parameters) herein is for example only; it is not guaranteed for volume production. SANYO believes information herein is accurate and reliable, but no guarantees are made or implied regarding its use or any infringements of intellectual property rights or other rights of third parties.

This catalog provides information as of February, 1998. Specifications and information herein are subject to change without notice.