



LC9005

High-Precision Low Voltage Detector

DESCRIPTION

LC9005 is a series of high precision voltage detector with ultra low current consumption (500nA typ. at V_{DD}=3.0V). It can work at very low voltage, which makes it perfect for system reset.

LC9005 is composed of high precision voltage reference, comparator, output driver and resistor array. Internally preset detect voltage has a low temperature drift and requires no external trimming.

One type of output, N-channel open-drain is available.

LC9005 is available in small size SOT23-3 package which is Pb free.

FEATURES

- High-precision detection Voltage: $\pm 3\%$
- Detection Voltage: 0.9V~6.0V (in 0.1V steps)
- Precise hysteresis: 4% typ.
- Operating Voltage range: 0.7V~10V
- Ultra-low current consumption: 500nA typ. (at V_{DD}=3.0V)

APPLICATIONS

- Power monitor for portable equipment such as PDA, DSC, Mobile phone, Notebook, MP3
- CPU and Logic Circuit Reset
- Battery Checker
- Battery Back-up Circuit
- Power Failure Detector

TYPICAL APPLICATION

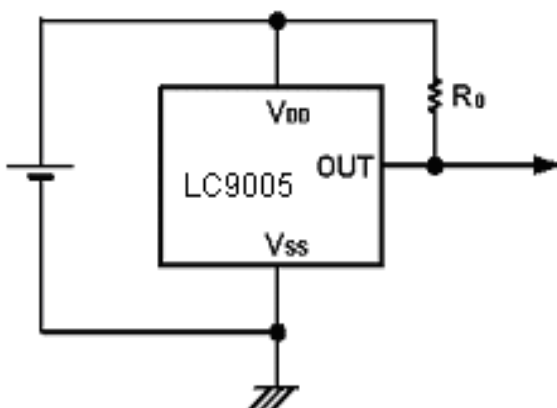

ELECTRICAL CHARACTERISTICS

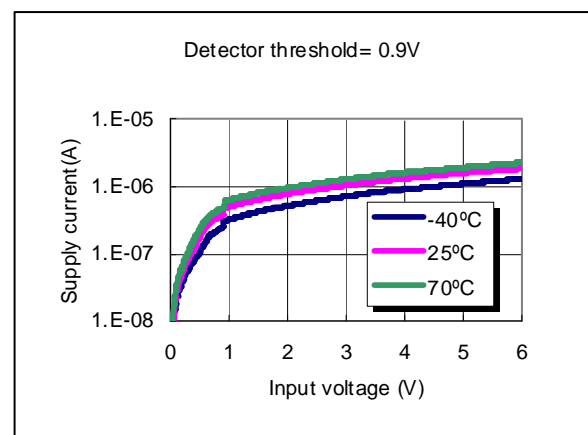

ORDERING INFORMATION

LC9005 [1](#) [2](#) [3](#) [4](#) [5](#)

Code	Description
1	Temperature&RoHS: C:-40~85°C ,Pb Free RoHS Std.
2	Package type: B3:SOT-23-3
3	Packing type: TR:Tape&Reel (Standard)
4	Output voltage: e.g. 09=0.9V 27=2.7V 60=6.0V
5	Output forms: N:N-channel open drain

PIN CONFIGURATION

Product Classification		LC9005CB3TR□□□	
Marking			
N5XX	N: N-channel open drain output type		
	5: Product Code		
	XX: Detector Voltage		
Vss	Ground Pin		
Vin	Supply Voltage Input		
Vout	Voltage detection output pin		

ABSOLUTE MAXIMUM RATING

Parameter	Value
Input Voltage	-0.3V-10V
Output Voltage range	-0.3V-12V
Maximum Output current	70mA
Ambient Temperature(Ta)	-40°C -85°C
Power Dissipation	SOT-23-3: 250mW
Storage Temperature(Ts)	-40°C -150°C
Lead Temperature & Time	260°C,10S

Note:

Exceed these limits to damage to the device.

Exposure to absolute maximum rating conditions may affect device reliability.

RECOMMENDED WORK CONDITIONS

Item	Min	Recommended	Max.	Unit
Input Voltage Range	0.7		10	V
Ambient Temperature	-40	25	85	°C

ELECTRICAL CHARACTERISTICS

LC9005CB3TR09N (Topt=25°C, Unless otherwise specified.)

Symbol	Parameter	Conditions	Reference Data			Unit
			Min.	Typ.	Max.	
-VDET	Detector Threshold		0.873	0.900	0.927	V
VHYS	Detector Threshold Hysteresis		0.018	0.036	0.054	V
ISS	Current Consumption	VDD=2.9V		1.0	2.5	uA
VDDH	Maximum Operating Voltage				10	V
VDDL	Minimum Operating Voltage			0.5		V
IOUT	Output Current	VDS=0.05V, VDD=0.7V VDS=0.50V, VDD=0.8V	0.01 0.05	0.05 0.50		mA
TPLH	Output Delay Time				20	uS

LC9005CXTR27N (Topt=25°C, Unless otherwise specified.)

Symbol	Parameter	Conditions	Reference Data			Unit
			Min.	Typ.	Max.	
-VDET	Detector Threshold		2.619	2.700	2.781	V
VHYS	Detector Threshold Hysteresis		0.054	0.108	0.162	V
ISS	Current Consumption	VDD=4.7V		0.5	2.5	uA
VDDH	Maximum Operating Voltage				10	V
VDDL	Minimum Operating Voltage			0.5		V
IOUT	Output Current	VDS=0.05V, VDD=0.7V	0.01	0.05		mA
TPLH	Output Delay Time				20	uS

LC9005CXTR30N (Topt=25°C, Unless otherwise specified.)

Symbol	Parameter	Conditions	Reference Data			Unit
			Min.	Typ.	Max.	
-VDET	Detector Threshold		2.91	3.00	3.09	V
VHYS	Detector Threshold Hysteresis		0.060	0.12	0.18	V
ISS	Current Consumption	VDD=5.0V		0.5	2.5	uA
VDDH	Maximum Operating Voltage				10	V
VDDL	Minimum Operating Voltage			0.5		V
IOUT	Output Current	VDS=0.05V, VDD=0.7V	0.01	0.05		mA
TPLH	Output Delay Time				20	uS

LC9005CXXTR34N (T_{opt}=25°C, Unless otherwise specified.)

Symbol	Parameter	Conditions	Reference Data			Unit
			Min.	Typ.	Max.	
-VDET	Detector Threshold		3.298	3.40	3.502	V
VHYS	Detector Threshold Hysteresis		0.068	0.136	0.204	V
ISS	Current Consumption	VDD=5.0V		0.5	2.5	uA
VDDH	Maximum Operating Voltage				10	V
VDDL	Minimum Operating Voltage			0.5		V
IOUT	Output Current	VDS=0.05V, VDD=0.7V	0.01	0.05		mA
TPLH	Output Delay Time				20	uS

LC9005CXXTR44N (T_{opt}=25°C, Unless otherwise specified.)

Symbol	Parameter	Conditions	Reference Data			Unit
			Min.	Typ.	Max.	
-VDET	Detector Threshold		4.268	4.40	4.532	V
VHYS	Detector Threshold Hysteresis		0.088	0.176	0.264	V
ISS	Current Consumption	VDD=6.4V		0.5	2.5	uA
VDDH	Maximum Operating Voltage				10	V
VDDL	Minimum Operating Voltage			0.5		V
IOUT	Output Current	VDS=0.05V, VDD=0.7V	0.01	0.05		mA
TPLH	Output Delay Time				20	uS

BLOCK DIAGRAM

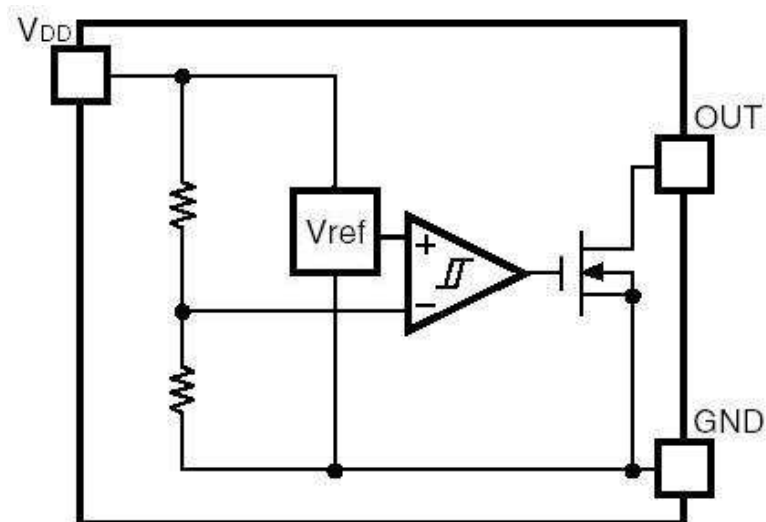

FUNCTION DESCRIPTION

In LC9005, a high precision low temperature coefficient reference voltage is applied to the negative input of a comparator. Input voltage, divided by resistor array of Ra, Rb and Rc, is applied to the positive input of the comparator. Output of the comparator controls a pair of NMOS and PMOS switches, generating the hysteresis. Output of the comparator passes a series of buffer to drive the output NMOS.

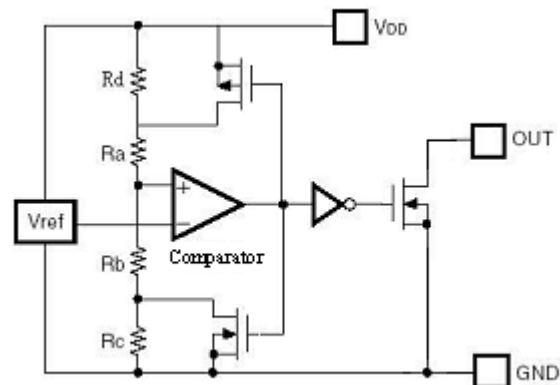

OUTPUT ACTION

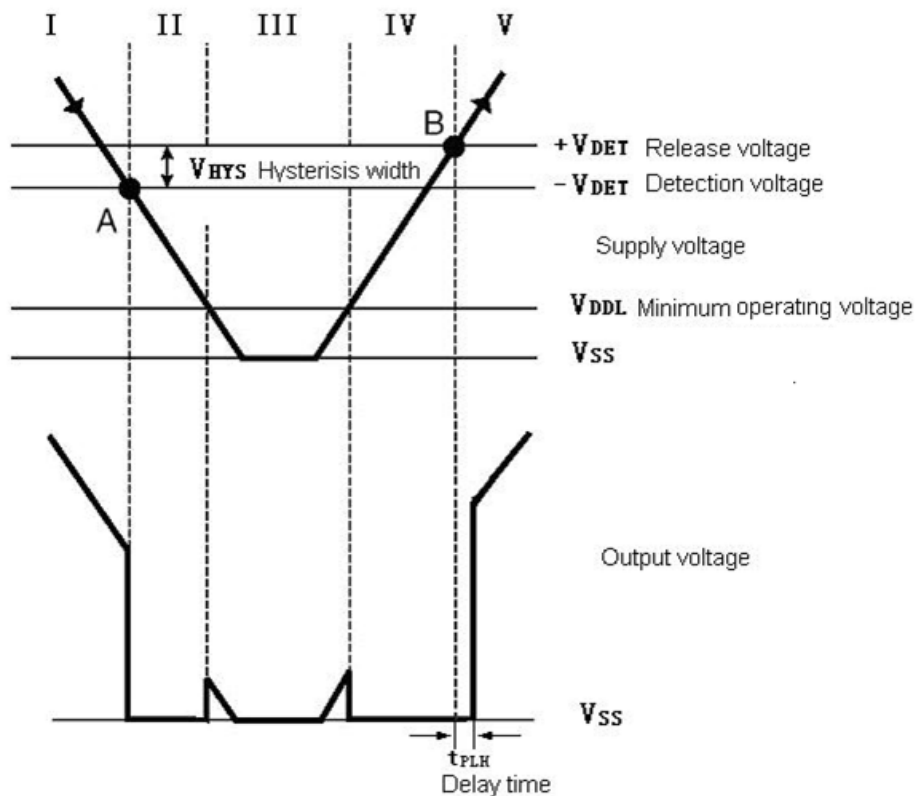

No.	Operation status	Output status
I	VDD > -VDET	Output voltage is equal to the supply voltage
II	VDD drops below -VDET	Output voltage equals to GND level
III	VDD drops further below VDDL	Output voltage is undefined
IV	VDD rises above VDDL	Output voltage equals to GND level
V	VDD rises above +VDET	Output voltage equals to supply voltage, $V_{HYS} = (+V_{DET}) - (-V_{DET})$

TYPICAL PERFORMANCE CHARACTERISTICS

1) Output voltage VS. Input voltage

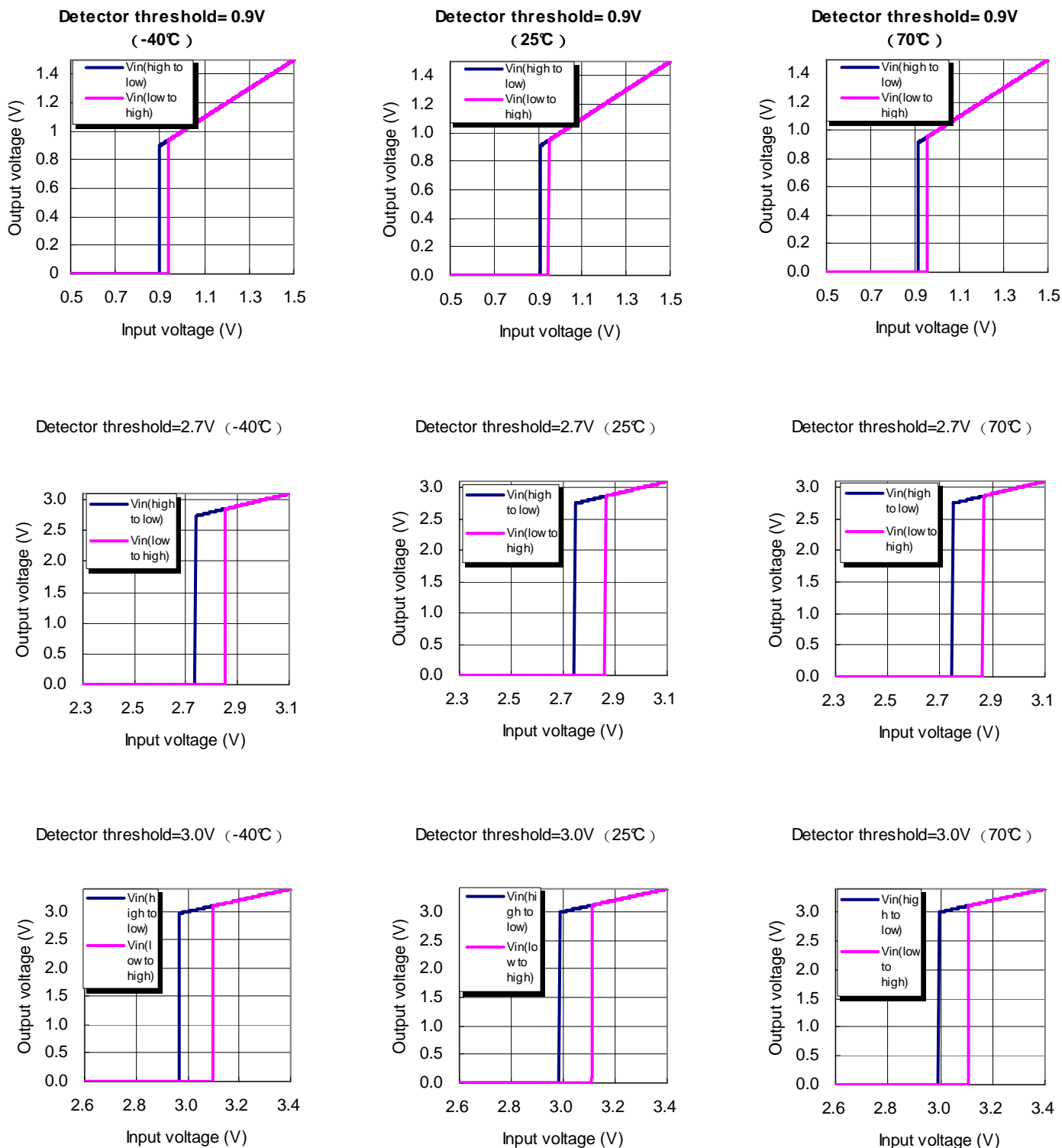

Detector threshold=4.4V (-40°C)

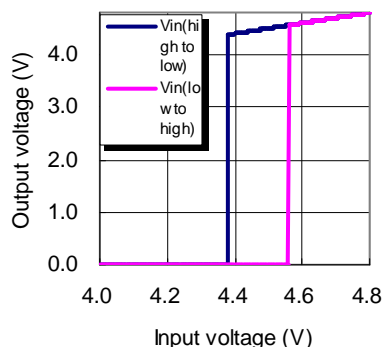

Detector threshold=4.4V (25°C)

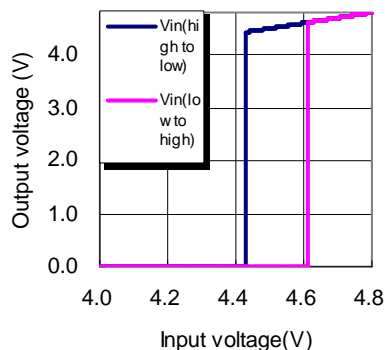

Detector threshold=4.4V (70°C)

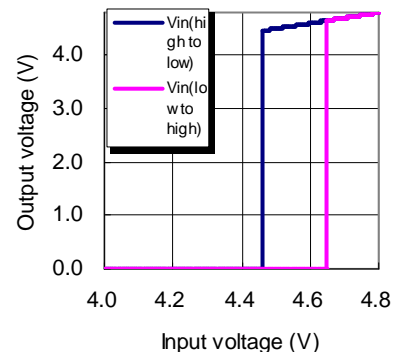

2) Supply current VS. Input voltage

Detector threshold=0.9V

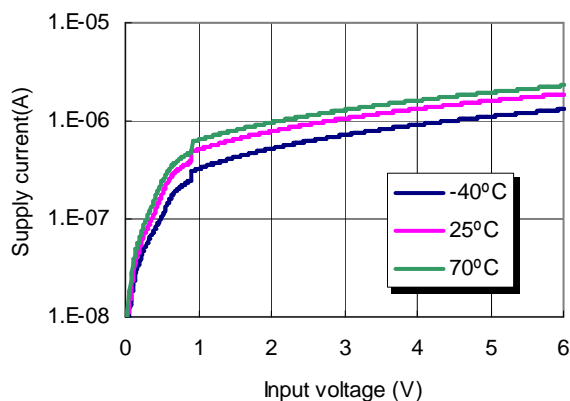

Detector threshold=2.7V

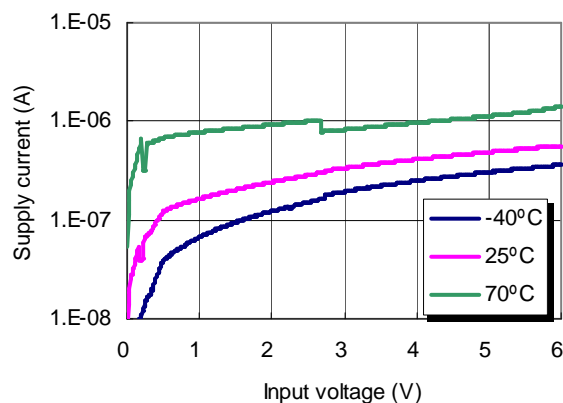

Detector threshold=3.0V

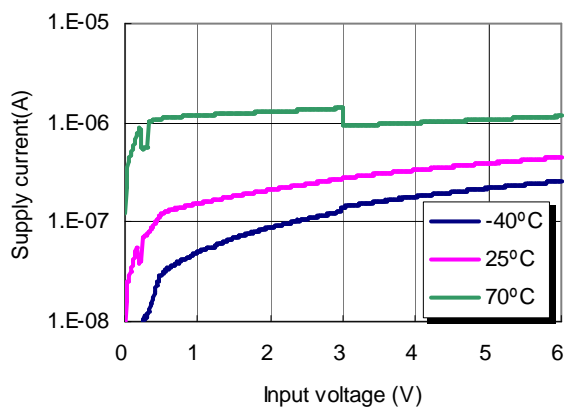

Detector threshold=4.4V

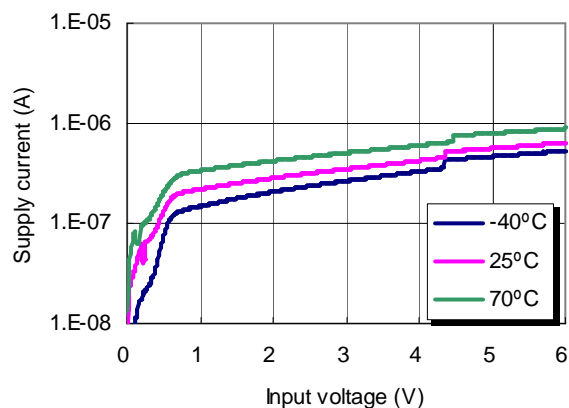

3) Detector Threshold Hysteresis VS. Temperature

Detector threshold= 0.9V

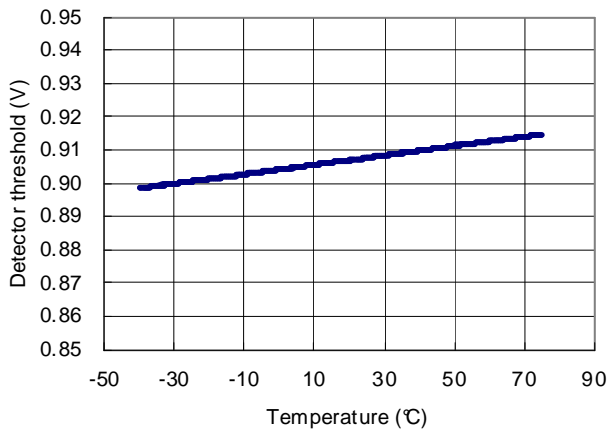

Detector threshold=2.7V

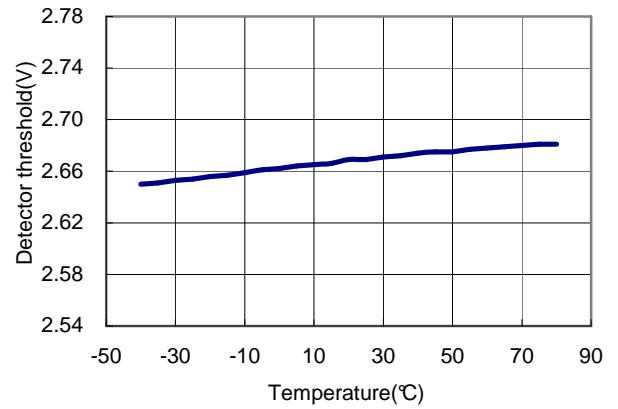

Detector threshold=3.0V

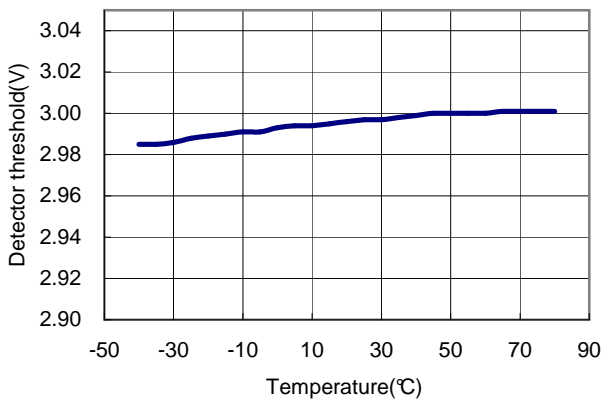

Detector threshold=4.4V

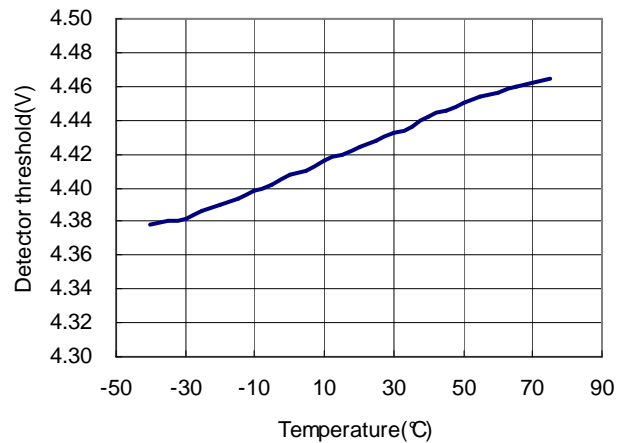

4) Driver Output Current VS. Vds

LC9005CXXTR09N

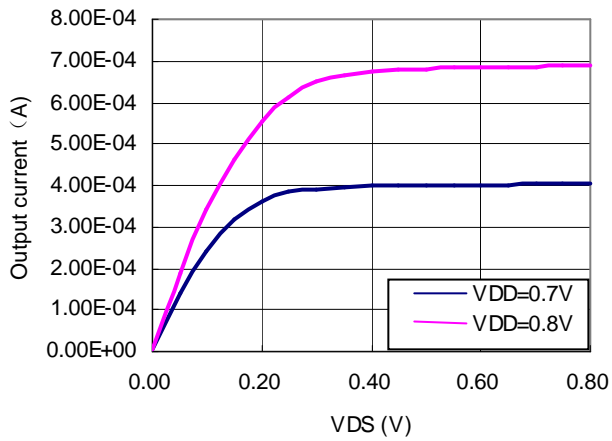

LC9005CXXTR27N

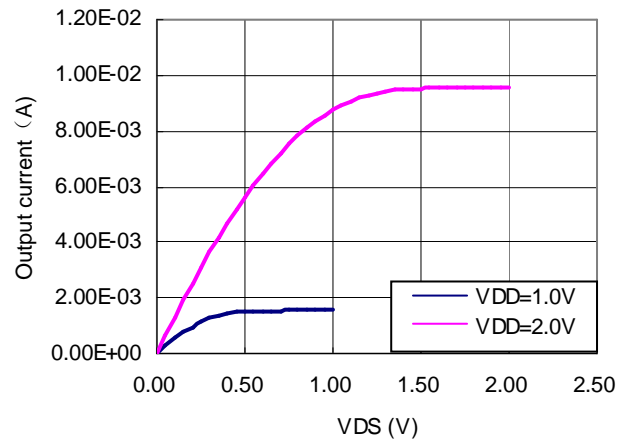

LC9005CXXTR30N

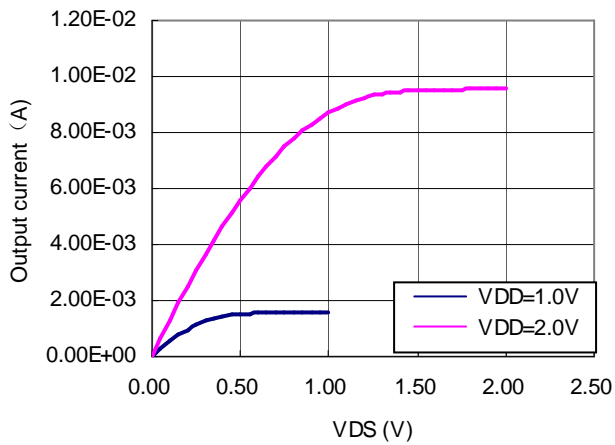

LC9005CXXTR44N

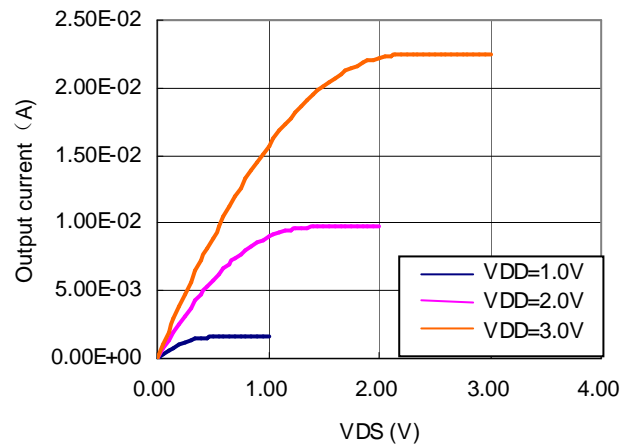

5) Driver Output Current vs. Input Voltage

Detector threshold=2.7V

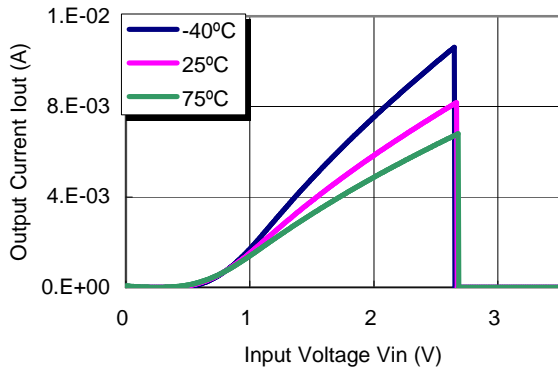

Detector threshold=3.0V

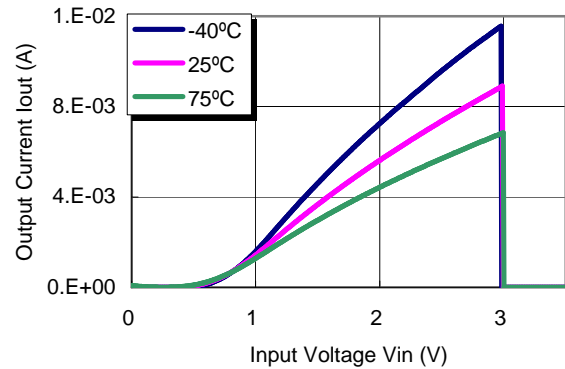

PACKAGE LINE

Package	SOT-23-3	Devices per reel	3000Pcs	Unit	mm
Package dimension:					