

NAN YA PLASTICS CORPORATION

SPECIFICATION OF
LCD MODULE
PRODUCT NO.: LCBA7T211M_

SPEC. NO.: LM211-0-9

CUSTOMER
APPROVED BY
DATE :

LCD DEPARTMENT
ELECTRONIC MATERIALS DIVISION
NAN YA PLASTICS CORPORATION
201, TUNG HWA N. ROAD, TAIPEI
TEL: 886-2-27122211 EXT. 5993~5995
FAX: 886-2-27178253
E-mail: lcdsales@npc.com.tw

EDITED ON : Jan. 10. 2007

Q.C. DEPT.	DESIGN MANAGER	DESIGN CHECK	DESIGNER
			W. R. HSU

RECORDS OF REVISION

SPEC. NO :
LM211-0

DATE	REVISED NO.	REF. PAGE	SUMMARY	DESIGN	CHECK
08.30.99'	0	25/25	First Issue	M.Y. Lin	Louis Lee
11.24.99'	1	1/25	Characteristics Modified	M.Y. Lin	Louis Lee
		3/25	Characteristics Modified		
		8/25	Block Diagram Modified		
		25/25	Dimension Modified		
05.24.00'	2	10/25	Add CCFL Inverter P/N	M.Y. Lin	Louis Lee
		16/25~19/25	Inspection Provision Modified		
		24/25	CCFL Operating Life Time Defined		
09.02.00'	3	1/25	Weight Modified	M.Y. Lin	Louis Lee
		3/25,5/25	Characteristics Modified		
		10/25	CCFL Inverter P/N Modified		
		24/25	CCFL CONDITION Defined		
02.05.01'	4	3/25,4/25	Characteristics Modified	C.H. SHU	M.Y. Lin
		11/25	Timing Characteristics Modified		
07.11.'01	5	1/25	P/N No. Modified	C.H. SHU	Louis Lee
		2/25,3/25,5/25	Characteristics Modified		
		10/25	CCFL Inverter P/N Modified		
		25/25	Wire Length Modified		
03.16.'05	6	1/25	Module Size Modified	W.R.HSU	Louis Lee
		25/25	Dimension Modified		
12.23.08'	7	3/25	Erased CCFL Characteristics	W.R.HSU	Louis Lee
		3-1/25	Added Lamp Data		
		3-2/25	Add Characteristics of Reommend Inverter		
		10/25	Recommended Inverter Modified		
03.02.06'	8	4/25	Characteristics Modified	W.R.HSU	Louis Lee
01.10.07'	9	3,3-1/25	Characteristics Modified	W.R.HSU	
		3-2,10/25	DIM Recommended Value Modified		

1. MECHANICAL DATA

(1) Product No.	LCBA7T211M_
(2) Module Size	76.8 (W)mm x 103.7 (H)mm x 6.75(D)mm
(3) Dot Size	0.234 (W)mm x 0.068 (H)mm
(4) Dot Pitch	0.249 (W)mm x 0.083 (H)mm
(5) Number of Dots	240 (W) x (320 xRGB (H)) Dots
(6) Duty	1/240
(7) LCD Display Mode	FSTN: Color STN Module REAR POLARIZER: Color Transmissive Type
(8) Viewing Direction	6 O'clock
(9) Backlight	CCFL
(10) Controller	Excluded
(11) DC/DC Converter	Excluded
(12) Weight	65.0 g(approx.)

Note :

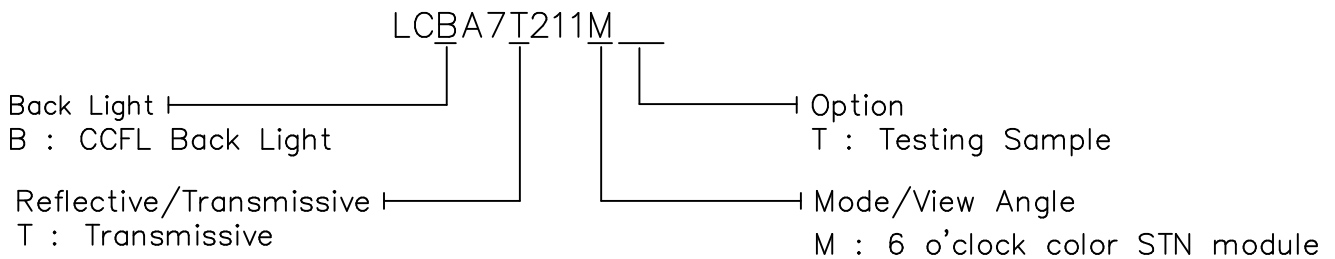

2. ABSOLUTE MAXIMUM RATINGS

(1) ELECTRICAL ABSOLUTE RATINGS

VSS=0V

ITEM	SYMBOL	MIN	MAX	UNIT	COMMENT
Power Supply for Logic	VDD-VSS	-0.3	7.0	V	
Power Supply for LCD Drive	VEE-VSS	0	30	V	
Input Voltage	VI	-0.3	VDD+0.3	V	
Static Electricity	-	-	-	-	Note 1

(2) ENVIRONMENTAL ABSOLUTE MAXIMUM RATINGS

ITEM	NORMAL TEMP.			
	OPERATING		STORAGE	
	MIN.	MAX.	MIN.	MAX.
Ambient Temperature	5	50	-20	60
Humidity (Without Condensation)	Note 2,4		Note 3,4	

Note 1 LCM should be grounded during handling LCM.

Note 2 $T_a \leq 50^\circ\text{C}$: 85%RH max

$T_a > 50^\circ\text{C}$: Absolute humidity must be lower
than the humidity of 85%RH at 50°C

Note 3 T_a at -20°C will be < 48 hrs, at 60°C will be < 120 hrs

Note 4 Background will color change slightly depending on ambient temperature.
That phenomenon is reversible.

3. ELECTRICAL CHARACTERISTICS

3-1. ELECTRICAL CHARACTERISTICS OF LCM

LCD

ITEM	SYMBOL	CONDITION	MIN.	TYP.	MAX.	UNIT		
Logic Circuit Power Supply	VDD-VSS	Ta= 25°C	3.0	3.3	3.6	V		
Input Voltage	VIH	H level	0.8VDD	-	VDD	V		
	VIL	L level	0	-	0.2VDD	V		
Recommended LCD Driving Voltage (Normal Temp. LCM)	VEE-VSS	Duty=1/240 VDD=3.3V	0°C	23.4	23.9	24.4	V	
			25°C	23.0	23.5	24.0		
			50°C	22.7	23.2	23.7		
Supply Current for Logic	IDD	VDD-VSS = 3.3V VEE-VSS = 23.5V Ta= 25°C	-	0.8	1.6	mA		
Supply Current for LCD	IEE	PATTERN: 	-	3.0	5.0	mA		
LCM	Surface Luminance	L	VDD-VSS=3.3V VEE-VSS=23.5V Ta= 25°C IL=2.5mA	PATTERN: (Dots All On of White Color)	70	89.0	-	cd/m ²
				PATTERN: (Dots All Off)	-	7.3	-	cd/m ²
Recommended Frame Frequency for Optimum Contrast	FLM	-	-	120	-	Hz		

3-2.ELECTRICAL CHARACTERISTICS OF BACKLIGHT

Used Lamp Rating

Temp.=25°C

ITEM	SYMBOL	MIN.	TYP.	MAX.	UNIT	REMARK
Lamp Voltage	V_L	-	332	-	Vrms	-
Lamp current	I_L	-	2.5	-	mArms	-
Lamp power consumption	P_L	-	0.83	-	W	(*1)
Starting voltage	V_S	-	-	940	Vrms	$T_a=25^\circ\text{C}$
		-	-	1230	Vrms	$T_a=0^\circ\text{C}$
Lamp life time	L_L	-	20000	-	hrs	at $I_L = 2.5 \text{ mArms}$ $T_a=25^\circ\text{C}$ (*2)

(*1) Power consumption excluded inverter loss .

(*2) Lamp life time is defined as follows : The final brightness is at 50% of original brightness .

(*3) a. Please follow the table of Lamp Characteristics shown above if not to use the inverter recommended by Nan Ya .

b. If customers want to design inverter by themselves , please inform Nan Ya to offer the detail lamp specification .

3-3.ELECTRICAL CHARACTERISTICS OF RECOMMENDED INVERTER TDK TAD695

3-3-1 GENERAL SPECIFICATIONS

OPERATION TEMPERATURE : 0°C~50°C

STORAGE TEMPERATURE : -20°C~60°C

DIMENSION : 62.0(L)mm x 10.0(W)mm x MAX 7.0(H)mm

3-3-2 PIN ASSIGNMENTS

INPUT (CN1) CONNECTOR :
E&T 1604-005-05

OUTPUT (CN2) CONNECTOR :
JST SM02B-BHSS-1-TB

NO.	FUNCTION
1	VIN
2	VIN
3	DIM
4	GND
5	GND

NO.	FUNCTION
1	HV
2	LV

3-3-3 RELATIONSHIP BETWEEN VDIM & TUBE CURRENT

ITEM	SYMBOL	MIN.	TYP.	MAX.	UNIT	REMARK
Input Voltage	VIN	3	-	5	V	
Tube Current Control Voltage	DIM	-	1.8	-	V	
Tube Current	IL	-	2.5	-	mA	
Working Frequency	F	50	55	65	KHz	

4. OPTICAL CHARACTERISTICS

4-1 Optical Char. of Normal Temp. Mode

AT Vop

ITEM MODE		Cr(Contrast Ratio)						θ (Viewing Angle)		ϕ (Viewing Angle)	
		5°C		25°C		50°C		25°C		25°C	
		MIN.	TYP.	MIN.	TYP.	MIN.	TYP.	MIN.	TYP.	MIN.	TYP.
T	M	15	25	20	32	5.5	8	-	97	-	±57
NOTE		NOTE 6						NOTE 5			

note:

T: TRANSMISSIVE
M: 6 O'CLOCK COLOR STN MODULE

AT $\phi=0^\circ$ $\theta=0^\circ$

ITEM	SYMBOL	CONDITION	MIN.	TYP.	MAX.	UNIT	NOTE
Response Time (rise)	Tr	5°C	550	700	850	ms	NOTE 2
		25°C	200	250	300		
		50°C	95	120	145		
Response Time (fall)	Tf	5°C	240	300	360	ms	NOTE 2
		25°C	65	80	95		
		50°C	45	60	75		

4-2 Color of CIE Coordinate

Ta = 25°C

ITEM		SYMBOL	CONDITION	VALUE	BRIGHTNESS (cd/m ²)	NOTE
Color of CIE Coordinate	Red	X	$\phi=0^\circ, \theta=0^\circ$	0.49	15.4	Note*
		y		0.34		
	Green	X		0.29	34.4	
		y		0.55		
	Blue	X		0.17	13.9	
		y		0.16		
	White	X		0.23	48.9	
		y		0.35		

Note* Measuring at position 3 on Fig.1
CIE chromaticity diagram

Tolerance : ± 0.05

Fig.1

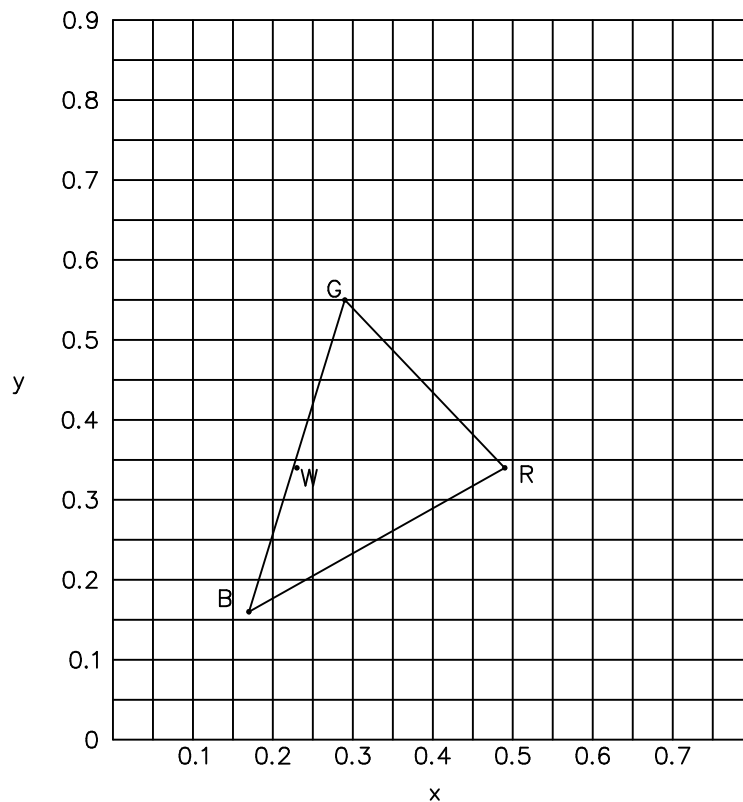

(NOTE 1)

Definition of Operation Voltage(Vop)

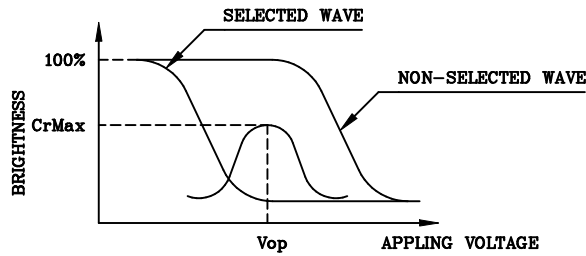

(positive type)

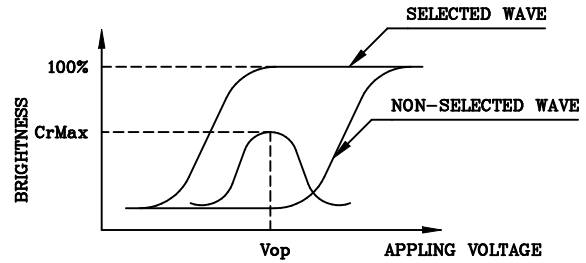

(negative type)

*Conditions

Viewing Angle : 0
Frame Frequency : 70Hz
Applying Waveform : 1/N duty 1/a bias

(NOTE 2)

Definition of Response Time(Tr,Tf)

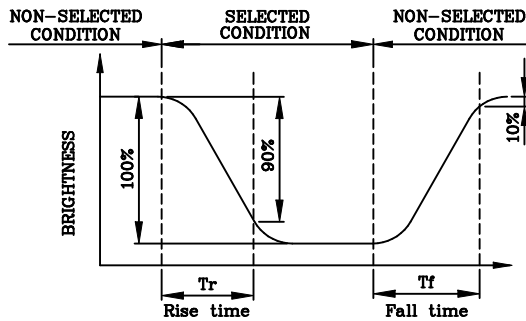

(positive type)

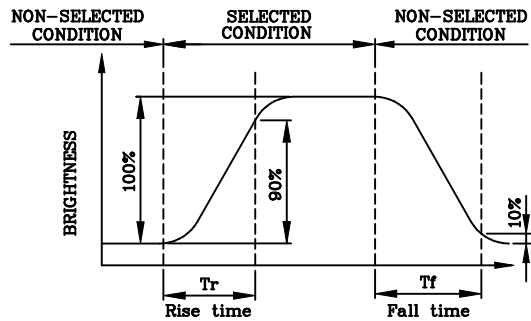

(negative type)

*Conditions

Operating Voltage : Vop
Viewing Angle (θ,φ) : (0,0)
Frame Frequency : 70Hz
Applying Waveform : 1/N duty 1/a bias

(NOTE 3)

Description of Measuring Equipment and Driving Waveforms

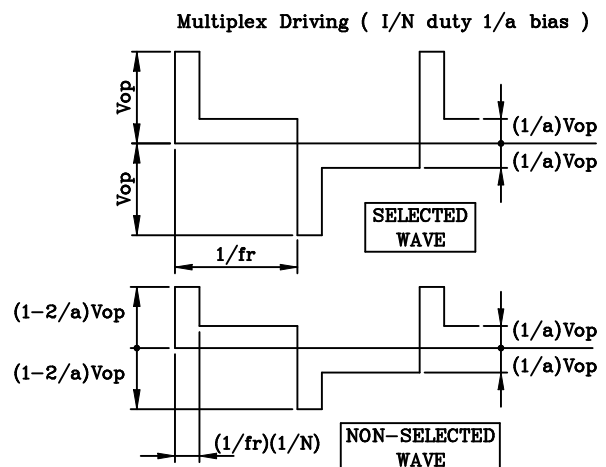
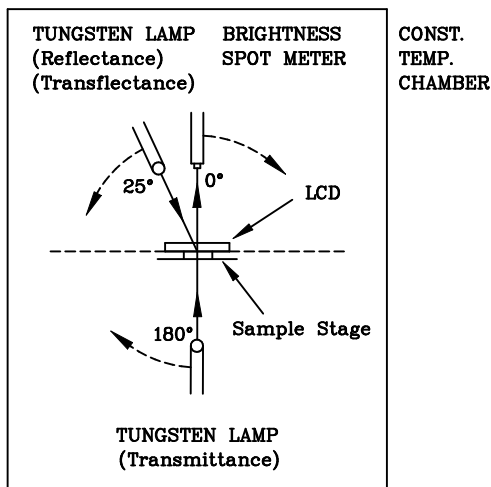

(NOTE 4)

Definition of Viewing Direction

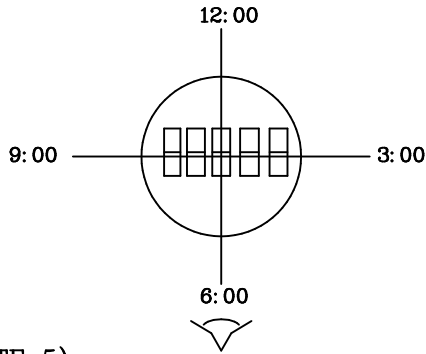

(NOTE 5)

Definition of Viewing Angle

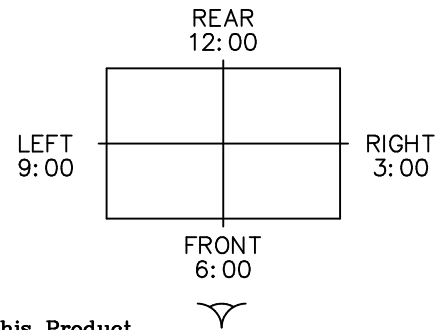
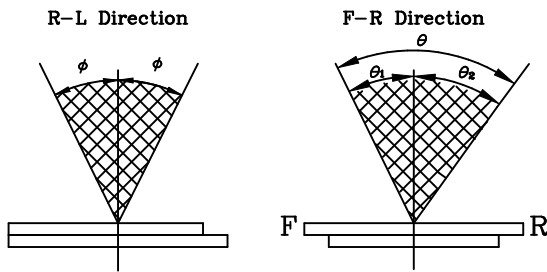

*For This Product
 The Viewing Direction Is 6 O'clock
 So $\theta_1 > \theta_2$

$$\theta = \theta_1 + \theta_2$$

*Conditions

Operating Voltage : V_{op}
 Frame Frequency : 70Hz
 Applying Waveform : 1/N duty 1/a bias
 Contrast Ratio : larger than 2

(NOTE 6)

Definition of Contrast Ratio (Cr)

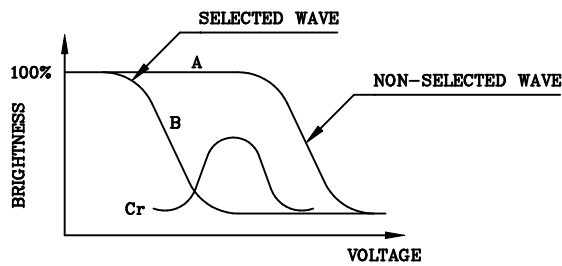

(positive type)

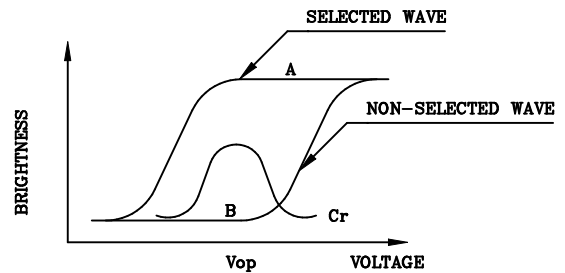

(negative type)

$$\text{Contrast Ratio : } Cr = A/B$$

*Conditions

Viewing Angle : 0
 Frame Frequency : 70Hz
 Applying Waveform : 1/N duty 1/a bias

5. BLOCK DIAGRAM

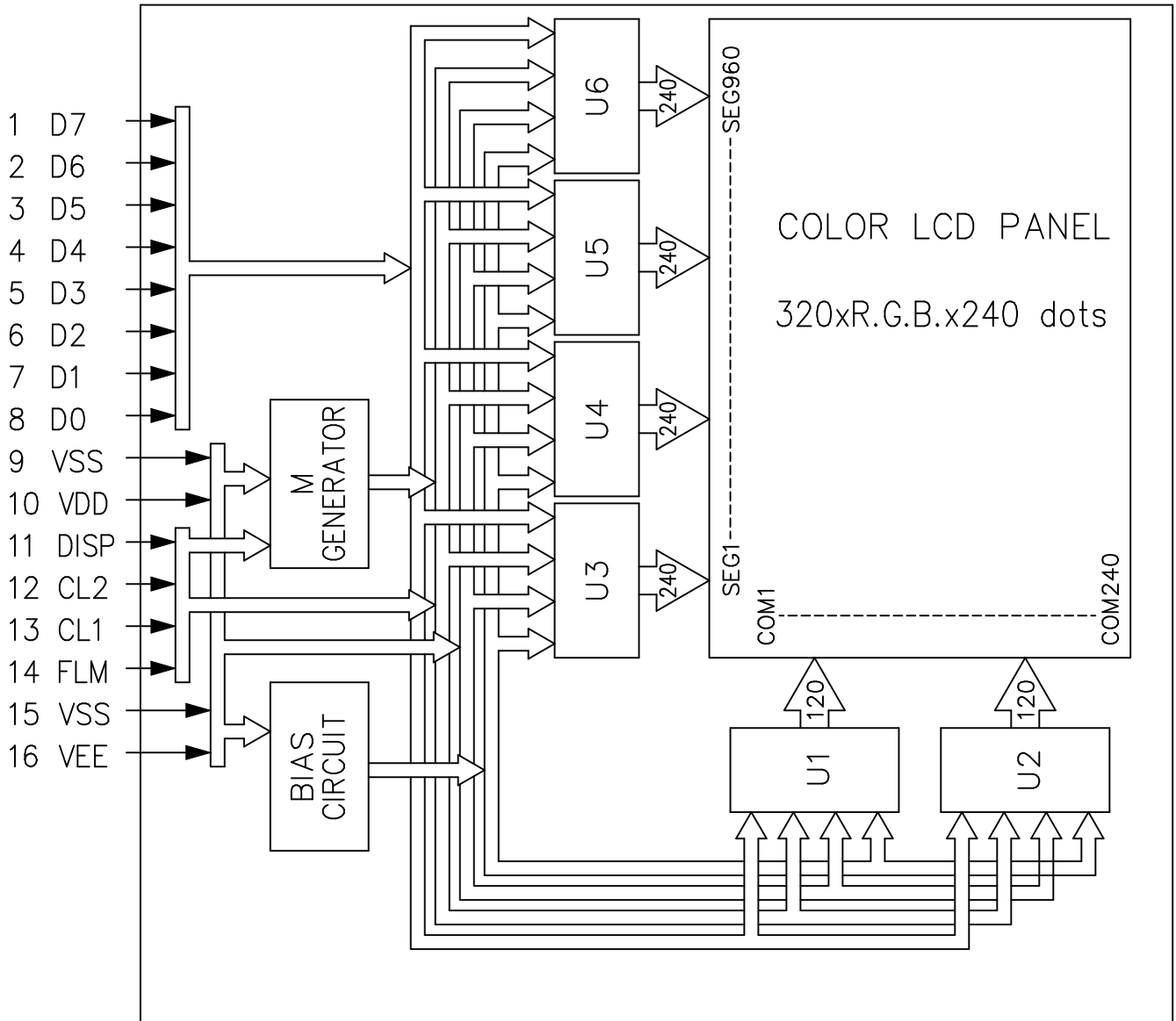

CCFL

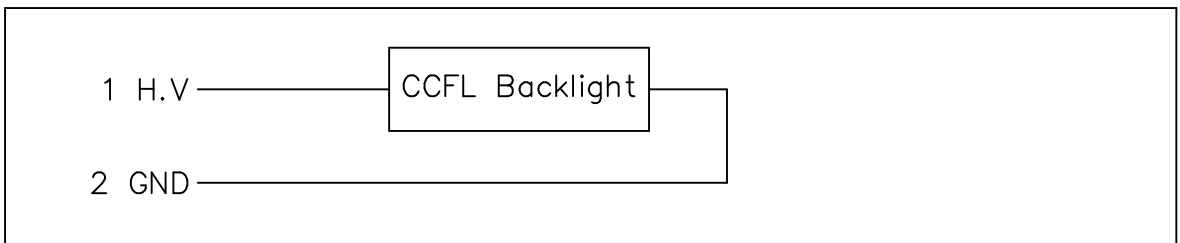

6. INTERNAL PIN CONNECTION

LCD

Pin No.	Symbol	Level	Function
1	D7	H/L	Display Data
2	D6	H/L	Display Data
3	D5	H/L	Display Data
4	D4	H/L	Display Data
5	D3	H/L	Display Data
6	D2	H/L	Display Data
7	D1	H/L	Display Data
8	D0	H/L	Display Data
9	VSS	-	GND
10	VDD	-	Power Supply for Logic
11	DISP	H/L	Display Control Signal, H :Display on L :Display off
12	CL2	H/L	Data input clock
13	CL1	H/L	Input data latch signal
14	FLM	H/L	Scan start-up signal
15	VSS	H/L	Power Supply (0V,GND)
16	VEE	-	Power Supply for LCD

CCFL

Pin No.	Symbol	Level	Function
1	H.V	-	Power Supply for CFL
2	GND	-	CFL GND

LCD INTERFACE CONNECTOR

FH12-16S-0.5SV (HIROSE)/Suitable FFC :pitch 0.5mm ,width 8.5mm

CCFL CONNECTOR :

BHSR -02VS-1 (JST)/Suitable Connector :SM02B-BHSS-1-TB (JST)

7. POWER SUPPLY

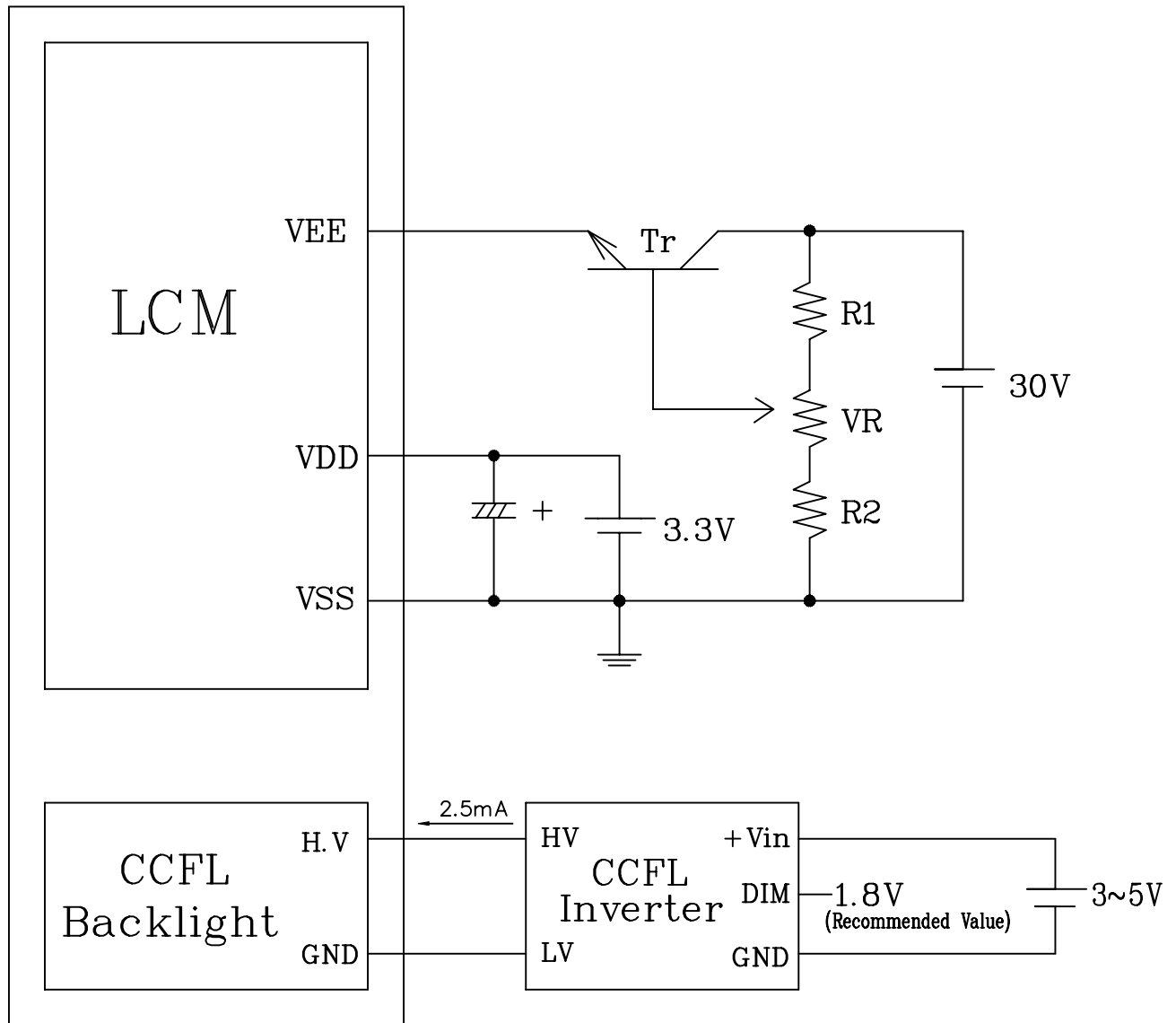

1. $R1 + R2 + VR = 10 \sim 20K \Omega$
2. RECOMMENDED CCFL INVERTER :
 TDK TAD695

8. TIMING CHARACTERISTICS

8-1 INTERFACE TIMING

VDD=3.3V ± 10%

Parameter	SYMBOL	MIN.	MAX.	UNIT
CLOCK CYCLE TIME	t_{cyc}	66	—	ns
CL2 HIGH LEVEL WIDTH	t_{cWH2}	23	—	ns
CL2 LOW LEVEL WIDTH	t_{cWL2}	23	—	ns
CL1 HIGH LEVEL WIDTH	t_{cWH1}	30	—	ns
CL2 SETUP TIME	t_{sCL}	30	—	ns
CL2 HOLD TIME	t_{HCL}	30	—	ns
CL2 - CL1 RISE TIME	t_{LD}	10	—	ns
CL1 - CL2 FALL TIME	t	30	—	ns
CLOCK RISE / FALL TIME	t_{ct}	5	—	ns
DATA SETUP TIME	t_{DS}	10	—	ns
DATA HOLD TIME	t_{DH}	25	—	ns
FLM SETUP TIME	t_{FLS}	30	—	ns
DATA HOLD TIME	t_{FLH}	50	—	ns

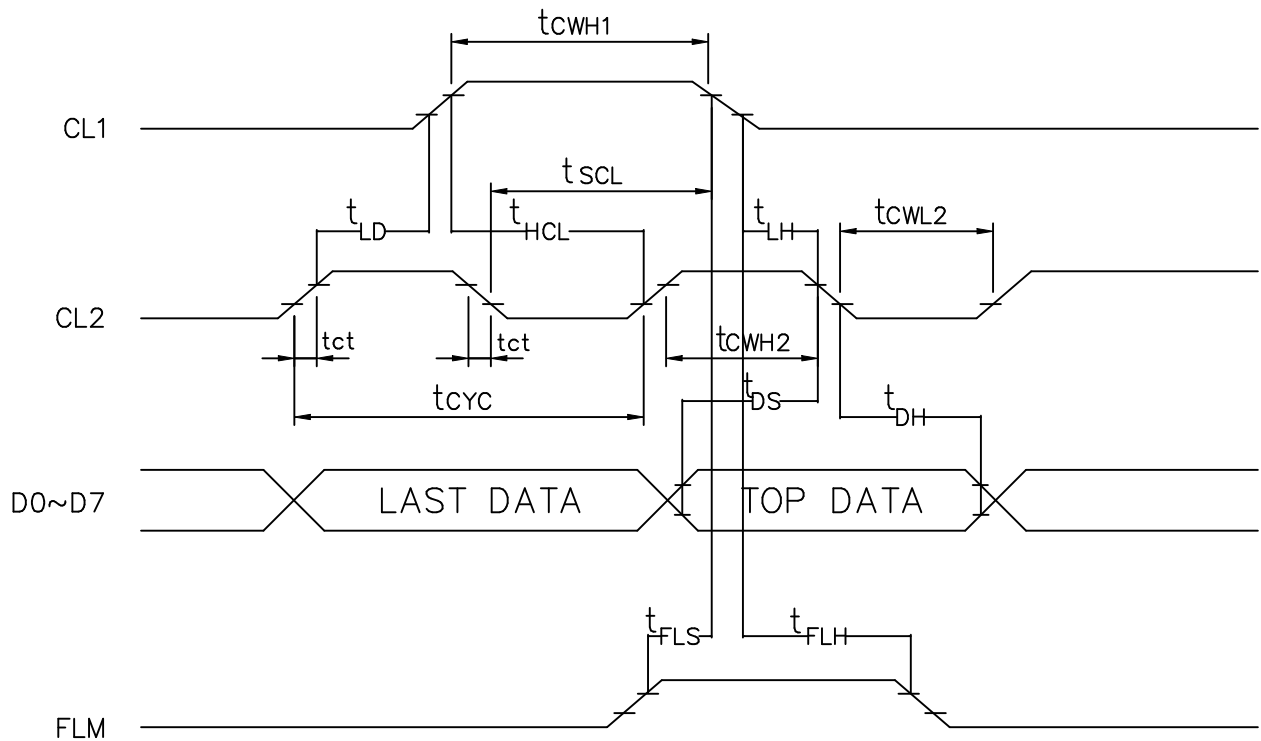

8-2 TIMING CHART OF INPUT SIGNAL

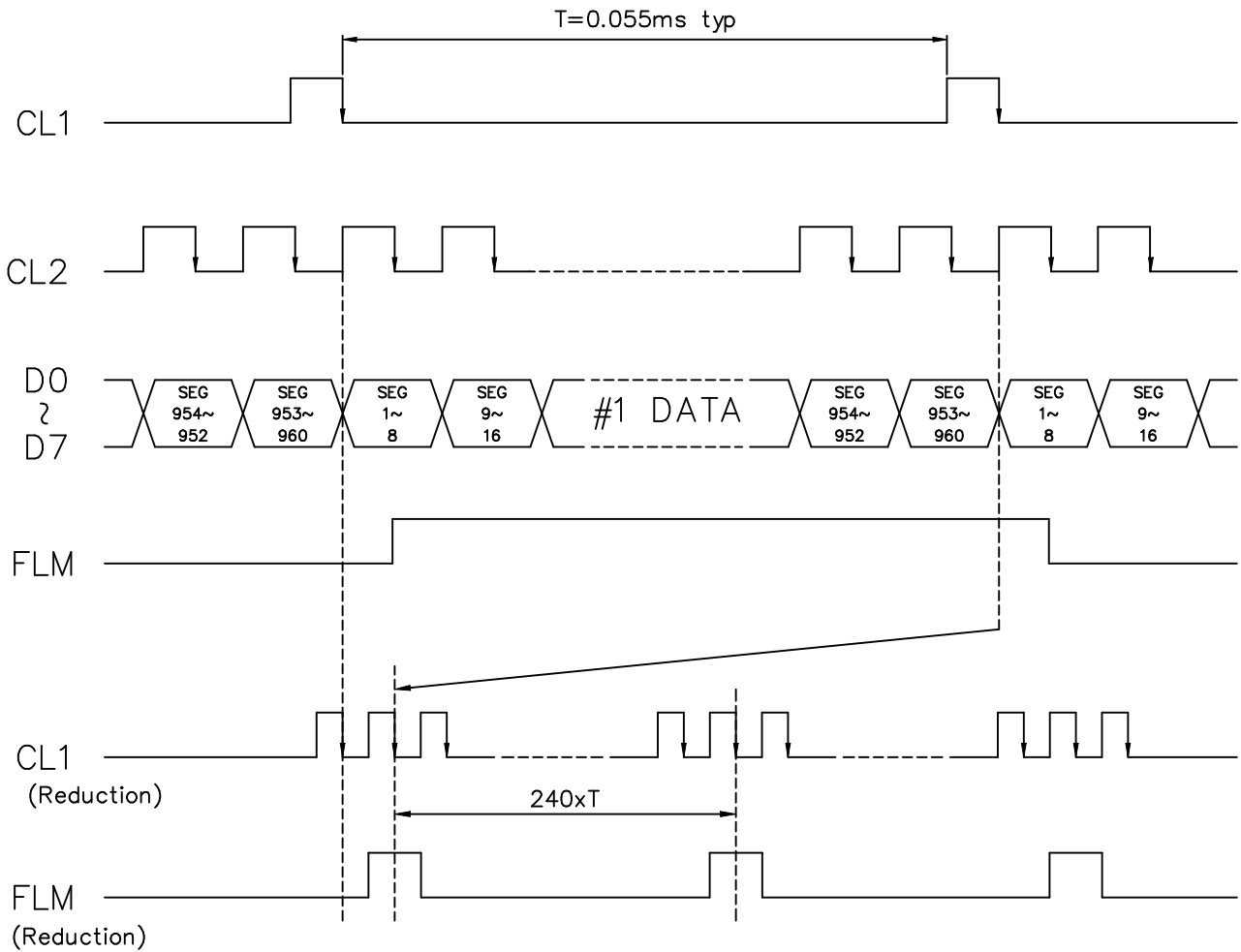

8-3 POWER ON/OFF TIMING

ON SEQUENCE

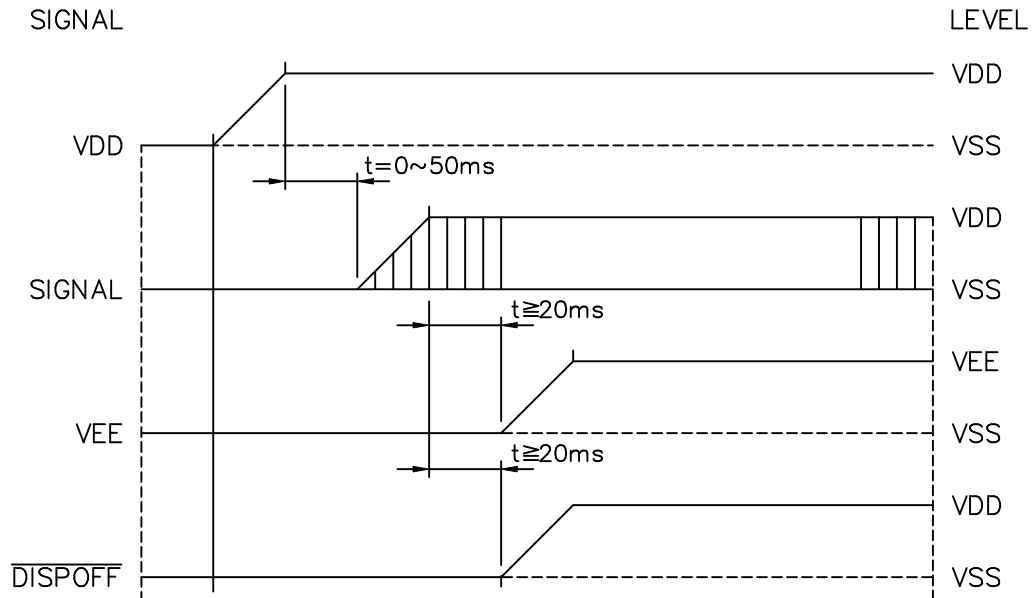

OFF SEQUENCE

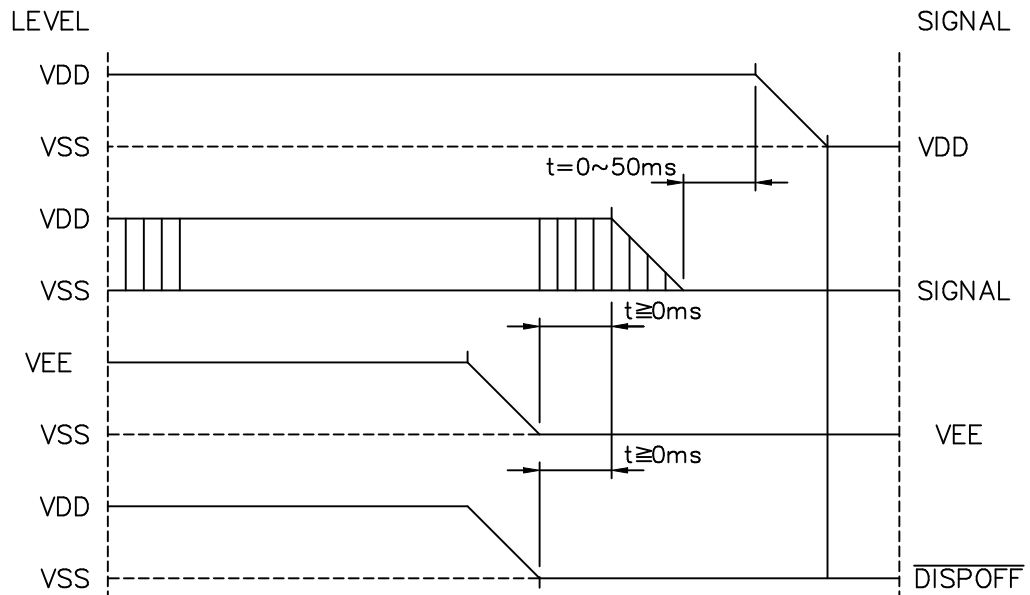

Please maintain the above sequence when turning on and off the power supply of the module. If $\overline{\text{DISPOFF}}$ is supplied to the module while internal alternate signal for LCD driving(M) is unstable, DC component will be supplied to the LCD panel. This may cause damage the LCD module.

8-4 DISPLAY PATTERN

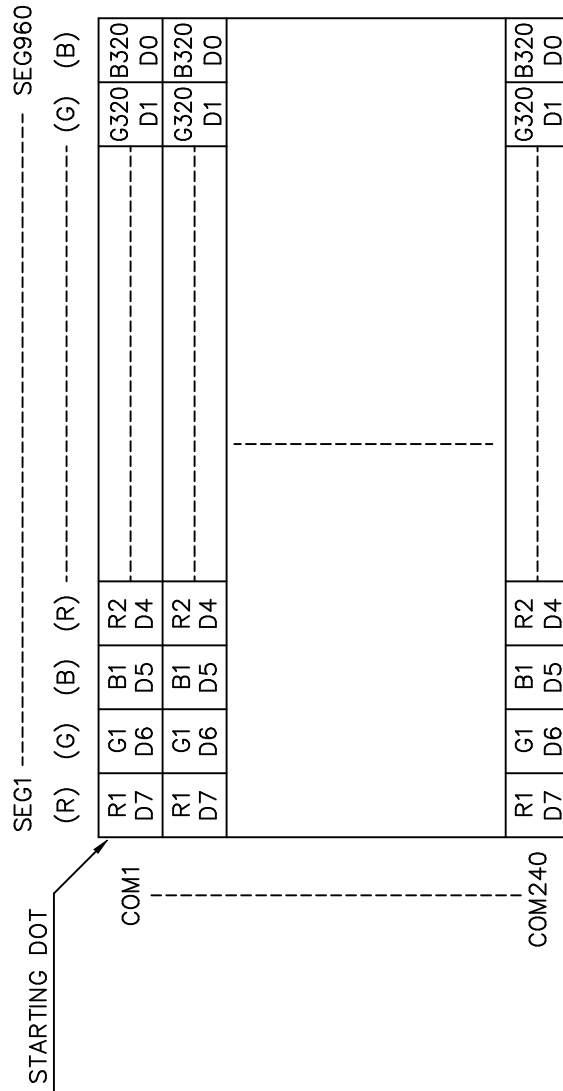

D0~D7 are 8 bits transmitted data, where D0 is LSB and D7 is MSB.

9. RELIABILITY TEST

NO	ITEM	CONDITION			STANDARD	NOTE
1	High Temp. Storage	70°C	120HR		Appearance without defect	
2	Low Temp. Storage	-20°C	120HR		Appearance without defect	
3	High Temp. & High Humi. Storage	40°C 90%RH	120HR		Appearance without defect	
4	Thermal Shock	-20°C,30min→25°C.5min →70°C,30min→25°C.5min (1cycle)			Appearance without defect	5 cycles

Inspection Provision

1. Purpose

The NAN YA inspection provision provides outgoing inspection provision and its expected quality level based on our outgoing inspection of NAN YA LCD produces.

2. Applicable Scope

The NAN YA inspection provision is applicable to the arrangement in regard to outgoing inspection and quality assurance after outgoing.

3. Technical Terms

3-1 NAN YA Technical Terms



4. Outgoing Inspection Provision

Outgoing inspection is according to the product inspection manual. (Per 1-1, 1-2 & 1-3)

4-1 Inspection Method

MIL-STD-105D Level II Regular inspection

4-2 Inspection Standard

	Item		AQL(%)	Remarks
Major Defect	Dots	Opens Shorts Erroneous operation	0.4	faults which substantially lower the practicality and the initial purpose difficult to achieve.
	Solder appearance	Shorts Loose		
	Cracks	Display surface cracks		

	Dimensions	External from Dimensions	0.4	
Minor Defect	Inside the glass	Black spots	0.65	faults which appear to pose almost no obstacle to the practicality, effective use, and operation.
	Polarizing plate	Scratches, foreign Matter, air bubbles, and peeling		
	Dots	Pinhole, deformation		
	Color tone	Color unevenness		
	Solder appearance	Cold solder Solder projections		

4-3 Inspection Provisions
*Viewing Area Definition

Fig. 1

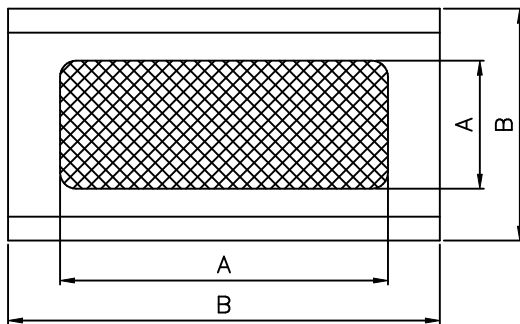

A : Zone Viewing Area
B : Zone Glass Plate Out Line

*Inspection place to be 500 to 1000 lux illuminance uniformly without glaring.
The distance between luminous source(daylight fluorescent lamp and cool white fluorescent lamp) and a sample to be 30cm to 50cm.

*Test and measurement are performed under the following conditions, unless otherwise specified.

Otherwise specified.

Temperature 20± 15°C
 Humidity 65± 20%R.H..
 Pressure 860~1060hPa(mmbar)

In case of doubtful judgment, it is performed under the following conditions.

Temperature 20± 2°C
 Humidity 65± 5%R.H..
 Pressure 860~1060hPa(mmbar)

5.Specification for quality check

5-1 Electrical characteristics

NO.	Item	Criterion
1.	Non operational	Fail
2.	Miss operating	Fail
3.	Missing dot	Fail
4.	Contrast irregular	Not allowable
5.	Response time	Within Specified value
6.	CCFL backlight turn on/off	Within Specified value

5-2 External Appearance Defect

NO.	Item	Criterion																							
1.	Black spots, foreign matter, and white spots (Including light leakage due to pinholes of polarizing plates, etc.)	<p>(1)-1-Spots(At non lighting condition)</p> <table border="1" data-bbox="727 481 1437 817"> <thead> <tr> <th>Average Diameter(mm):D</th> <th>Number of pieces permitted</th> <th>Minimum Space</th> </tr> </thead> <tbody> <tr> <td>$D \leq 0.2$</td> <td>Ignore</td> <td>-</td> </tr> <tr> <td>$0.2 < D \leq 0.3$</td> <td>5</td> <td>10mm</td> </tr> <tr> <td>$0.3 < D \leq 0.4$</td> <td>2</td> <td>30mm</td> </tr> <tr> <td>$0.4 < D$</td> <td>0</td> <td></td> </tr> </tbody> </table> <p>Number of total pieces is set to within 5 pieces.</p> <p>Note that when there are 2 pieces or more, they are not to be concentrated. Set as: Average diameter = (Long diameter + Short diameter)/2</p> <p>(1)-2-Spots(At lighting condition)</p> <table border="1" data-bbox="727 1238 1370 1478"> <thead> <tr> <th>Average Diameter(mm):D</th> <th>Number of pieces permitted</th> </tr> </thead> <tbody> <tr> <td>$D \leq 0.3$</td> <td>Ignore</td> </tr> <tr> <td>$0.3 < D \leq 0.75$</td> <td>5</td> </tr> <tr> <td>$0.75 < D$</td> <td>0</td> </tr> </tbody> </table> <p>Number of total pieces is set to within 5 pieces.</p> <p>Note that when there are 2 pieces or more, they are not to be concentrated. Set as: Average diameter = (Long diameter + Short diameter)/2</p>	Average Diameter(mm):D	Number of pieces permitted	Minimum Space	$D \leq 0.2$	Ignore	-	$0.2 < D \leq 0.3$	5	10mm	$0.3 < D \leq 0.4$	2	30mm	$0.4 < D$	0		Average Diameter(mm):D	Number of pieces permitted	$D \leq 0.3$	Ignore	$0.3 < D \leq 0.75$	5	$0.75 < D$	0
Average Diameter(mm):D	Number of pieces permitted	Minimum Space																							
$D \leq 0.2$	Ignore	-																							
$0.2 < D \leq 0.3$	5	10mm																							
$0.3 < D \leq 0.4$	2	30mm																							
$0.4 < D$	0																								
Average Diameter(mm):D	Number of pieces permitted																								
$D \leq 0.3$	Ignore																								
$0.3 < D \leq 0.75$	5																								
$0.75 < D$	0																								

1.	Black spots, foreign matter, and white spots (Including light leakage due to pinholes of polarizing plates, etc.)	<p>(1)-1 Spots(At non lighting condition)</p> <table border="1" data-bbox="724 432 1469 719"> <thead> <tr> <th>Width(mm): W</th> <th>Length(mm): L</th> <th>Number of pieces permitted</th> </tr> </thead> <tbody> <tr> <td>$W \leq 0.03$</td> <td>Ignore</td> <td>Ignore</td> </tr> <tr> <td>$0.03 < W \leq 0.08$</td> <td>$L \leq 4$</td> <td>2</td> </tr> <tr> <td>$0.08 < W \leq 0.1$</td> <td>$L \leq 1$</td> <td>1</td> </tr> </tbody> </table> <p>Object exceeding 0.1mm follow the standards of the spots form. Note that when there are 2 pieces or more, they are not to be concentrated.</p> <p>(1)-2 Spots(At lighting condition)</p> <table border="1" data-bbox="724 1021 1469 1308"> <thead> <tr> <th>Width(mm): W</th> <th>Length(mm): L</th> <th>Number of pieces permitted</th> </tr> </thead> <tbody> <tr> <td>$W \leq 0.03$</td> <td>Ignore</td> <td>Ignore</td> </tr> <tr> <td>$0.03 < W \leq 0.08$</td> <td>$L \leq 3$</td> <td>6</td> </tr> <tr> <td>$0.08 < W$</td> <td>$3 < L$</td> <td>None</td> </tr> </tbody> </table> <p>Object exceeding 0.1mm follow the standards of the spots form. Note that when there are 2 pieces or more, they are not to be concentrated.</p>	Width(mm): W	Length(mm): L	Number of pieces permitted	$W \leq 0.03$	Ignore	Ignore	$0.03 < W \leq 0.08$	$L \leq 4$	2	$0.08 < W \leq 0.1$	$L \leq 1$	1	Width(mm): W	Length(mm): L	Number of pieces permitted	$W \leq 0.03$	Ignore	Ignore	$0.03 < W \leq 0.08$	$L \leq 3$	6	$0.08 < W$	$3 < L$	None
Width(mm): W	Length(mm): L	Number of pieces permitted																								
$W \leq 0.03$	Ignore	Ignore																								
$0.03 < W \leq 0.08$	$L \leq 4$	2																								
$0.08 < W \leq 0.1$	$L \leq 1$	1																								
Width(mm): W	Length(mm): L	Number of pieces permitted																								
$W \leq 0.03$	Ignore	Ignore																								
$0.03 < W \leq 0.08$	$L \leq 3$	6																								
$0.08 < W$	$3 < L$	None																								
2.	Scratches(Glass, reflection plates, and polarizing plates)	In accordance with black spots. (At non lighting condition)																								
3.	Color irregular	Not remarkable color irregular.																								

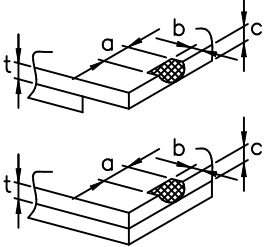
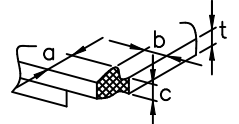
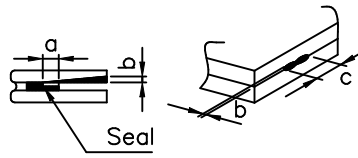
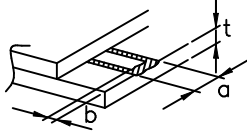
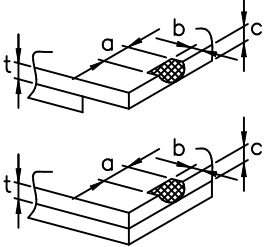
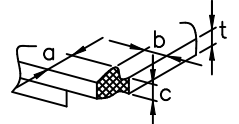
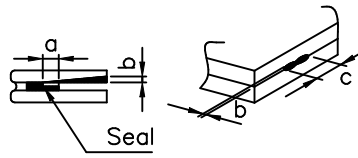
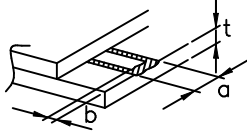
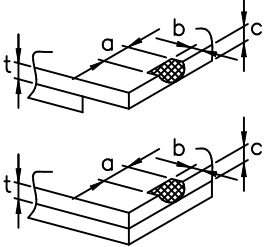
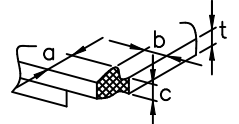
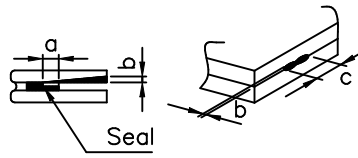
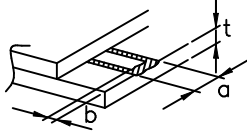
<p>4. Air bubbles polarizing plates, and reflection plates</p>	<table border="1" data-bbox="726 380 1241 672"> <tr> <th data-bbox="726 380 981 526">Average Diameter (mm):D</th> <th data-bbox="981 380 1241 526">Number of pieces permitted</th> <th data-bbox="1241 380 1495 672" rowspan="2">Average diameter = (Long diameter + Short diameter)/2</th> </tr> <tr> <td data-bbox="726 526 981 571">$D \leq 0.3$</td> <td data-bbox="981 526 1241 571">Ignore</td> </tr> <tr> <td data-bbox="726 571 981 672">$0.3 < D$</td> <td data-bbox="981 571 1241 672">0</td> <td></td> </tr> </table> <p data-bbox="726 683 1495 779">Note that when there are 4 pieces or more, they are not to be concentrated.</p>	Average Diameter (mm):D	Number of pieces permitted	Average diameter = (Long diameter + Short diameter)/2	$D \leq 0.3$	Ignore	$0.3 < D$	0			
Average Diameter (mm):D	Number of pieces permitted	Average diameter = (Long diameter + Short diameter)/2									
$D \leq 0.3$	Ignore										
$0.3 < D$	0										
<p>5. Cracks</p>	<table border="1" data-bbox="678 779 1495 1971"> <tr> <td data-bbox="678 779 1077 1176"> <p>(1)General crack</p>  </td> <td data-bbox="1077 779 1495 1176"> <p>$a \leq 5$ $b \leq 2$ $c \leq t$</p> <p>Where, a and b are ignored when less than or equal 0.5. The numbers of pieces are set at up to 5 pieces.</p> </td> </tr> <tr> <td data-bbox="678 1176 1077 1366"> <p>(2)Corner crack</p>  </td> <td data-bbox="1077 1176 1495 1366"> <p>$a \leq 2.5$ $b \leq 2.5$ $c \leq t$ $a + b \leq 4$</p> </td> </tr> <tr> <td data-bbox="678 1366 1077 1635"> <p>(3)Seal portion crack</p>  </td> <td data-bbox="1077 1366 1495 1635"> <p>$a \leq \text{The seal width} \times 1/3$ $b \leq t \times 2/3$ $c \leq 5$</p> <p>The numbers of pieces are set at up to 5 pieces.</p> </td> </tr> <tr> <td data-bbox="678 1635 1077 1870"> <p>(4)ITO Pin crack</p>  </td> <td data-bbox="1077 1635 1495 1870"> <p>$a \leq 5$ $b \leq 1/3 \text{ pin length}$ $c \leq t$</p> </td> </tr> <tr> <td data-bbox="678 1870 1077 1971"> <p>(5)Progressive cracks</p> </td> <td data-bbox="1077 1870 1495 1971"> <p>All taken to be unacceptable.</p> </td> </tr> </table>	<p>(1)General crack</p> 	<p>$a \leq 5$ $b \leq 2$ $c \leq t$</p> <p>Where, a and b are ignored when less than or equal 0.5. The numbers of pieces are set at up to 5 pieces.</p>	<p>(2)Corner crack</p> 	<p>$a \leq 2.5$ $b \leq 2.5$ $c \leq t$ $a + b \leq 4$</p>	<p>(3)Seal portion crack</p> 	<p>$a \leq \text{The seal width} \times 1/3$ $b \leq t \times 2/3$ $c \leq 5$</p> <p>The numbers of pieces are set at up to 5 pieces.</p>	<p>(4)ITO Pin crack</p> 	<p>$a \leq 5$ $b \leq 1/3 \text{ pin length}$ $c \leq t$</p>	<p>(5)Progressive cracks</p>	<p>All taken to be unacceptable.</p>
<p>(1)General crack</p> 	<p>$a \leq 5$ $b \leq 2$ $c \leq t$</p> <p>Where, a and b are ignored when less than or equal 0.5. The numbers of pieces are set at up to 5 pieces.</p>										
<p>(2)Corner crack</p> 	<p>$a \leq 2.5$ $b \leq 2.5$ $c \leq t$ $a + b \leq 4$</p>										
<p>(3)Seal portion crack</p> 	<p>$a \leq \text{The seal width} \times 1/3$ $b \leq t \times 2/3$ $c \leq 5$</p> <p>The numbers of pieces are set at up to 5 pieces.</p>										
<p>(4)ITO Pin crack</p> 	<p>$a \leq 5$ $b \leq 1/3 \text{ pin length}$ $c \leq t$</p>										
<p>(5)Progressive cracks</p>	<p>All taken to be unacceptable.</p>										

SPECIFICATION

6.	Outer dimensions	Should be with in the tolerance.
7.	Newton ring	Orbicular of interference fringes. To be non. In case of doubtful judgenemt, agreement shall be reachment.
8.	Soldering	Should be no defective soldering such as shorting, loose terminal cold solder, peeling of printed circuit board pattern, improper mouting position, etc.

5-3 Dot Appearance Defect

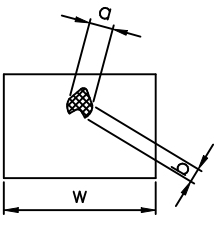
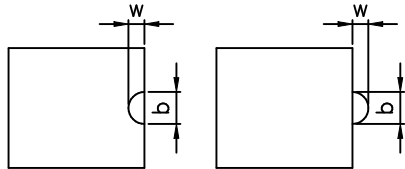
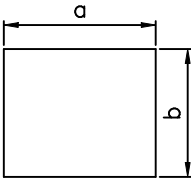
NO.	Item	Criteria
1.	Pinhole	 <p>Dot display a and b are each $\leq 0.2\text{mm}$ The overall total is taken be with in 10 units. Note that they are not to be concentrated.</p>
2.	Missing	 <p>Dot display a and b are each $\leq 0.2\text{mm}$ The overall total is taken to be with in 10 units.</p>
3.	Thick and thin display	 <p>Taken to be within $\pm 1.5\%$ of display character width(a) and height(b).</p>

(2) NOTE:

• SAFETY

- 1.If the LCD panel breaks, be careful not to get the liquid crystal to touch your skin.
- 2.If the liquid crystal touches your skin or clothes, please wash it off immediately by using soap and water.

• HANDLING

- 1.Avoid static electricity which can damage the CMOS LSI.
- 2.Do not remove the panel or frame from the module.
- 3.The polarizing plate of the display is very fragile. So, please handle it very carefully.
- 4.Do not wipe the polarizing plate with a dry cloth, as it may easily scratch the surface of plate.
- 5.Do not use ketonics solvent & Aromatic solvent, use with a soft cloth soaked with a cleaning naphtha solvent.

• STORAGE

- 1.Store the panel or module in a dark place where the temperature is $25^{\circ}\text{C}\pm 5^{\circ}\text{C}$ and the humidity is below 65% RH.
- 2.Do not place the module near organics solvents or corrosive gases.
- 3.Do not crush, shake, or jolt the module.

• TERMS OF WARRANT

- 1.Acceptance inspection period
The period is within one month after the arrival of contracted commodity at the buyer's factory site.
- 2.Applicable warrant period
The period is within twelve months since the date of shipping out under normal using and storage conditions.

• THE OPERATING LIFE TIME OF BACK LIGHT

- CCFT : 20,000hrs for lamp-current 2.5mA, 40KHz, 25°C
(Operating life time is defined as follows : The final brightness is at 50% of original brightness.)

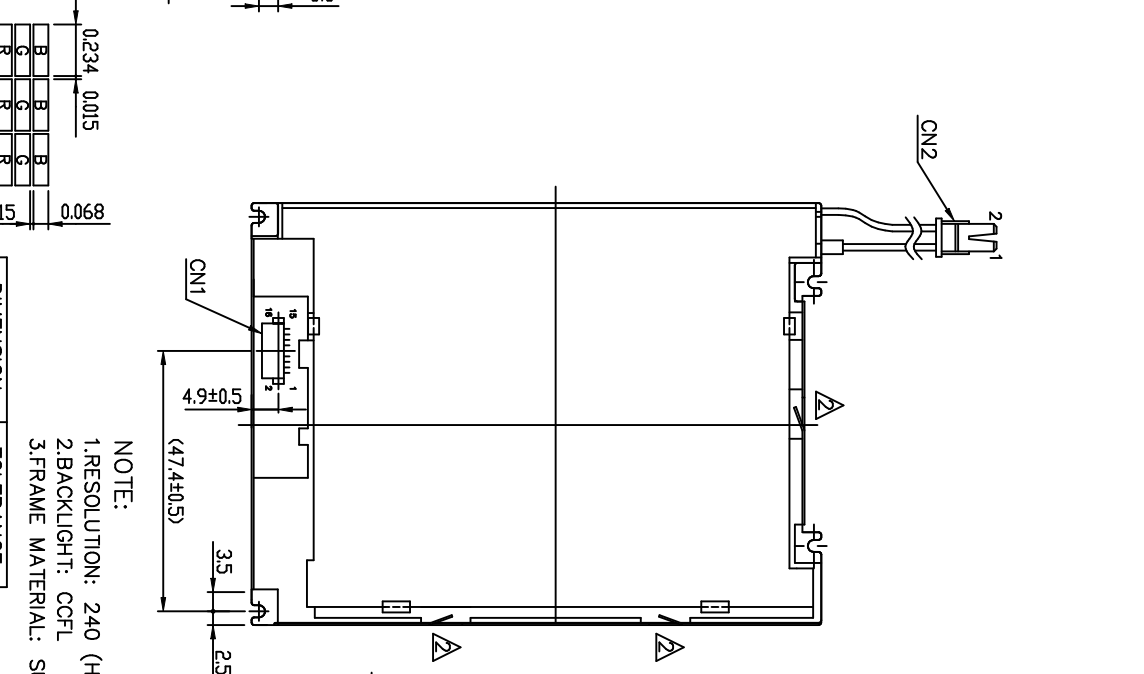
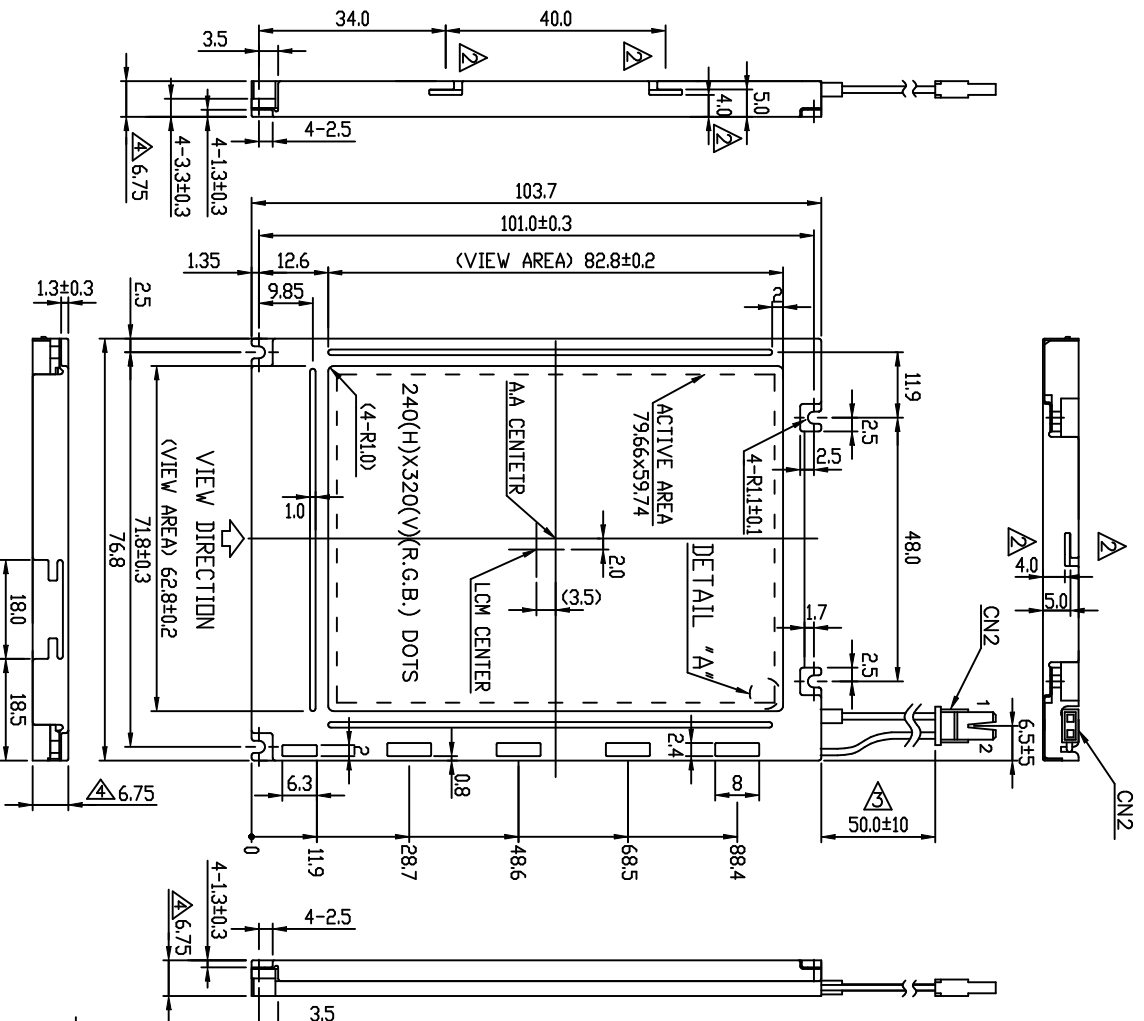

			Y320					
R1	G1	B1	R2	G2	B2	R3	R2	R3
D7	D6	D5	D4	D3	D2	D1	D0	D7
			R320	G320	B320			
			D2	D1	D0			

DISPLAY PATTERN

NOTE:

- 1.RESOLUTION: 240 (H) X 320 (V)(R.G.B.) DOTS
- 2.BACKLIGHT: CCFL
- 3.FRAME MATERIAL: SUS304 (0.3mm)

CN1 : FH12-16S-0.55V(HRS)/SUITABLE FPC : PITCH 0.5mm WIDTH 8.5mm		
PIN NO	SYMBOL	FUNCTION
1	D7	DISPLAY DATA
2	D6	DISPLAY DATA
3	D5	DISPLAY DATA
4	D4	DISPLAY DATA
5	D3	DISPLAY DATA
6	D2	DISPLAY DATA
7	D1	DISPLAY DATA
8	D0	DISPLAY DATA
9	Vss	GROUND
10	Vpd	LOGIC SUPPLY VOLTAGE

PIN NO	SYMBOL	FUNCTION
11	DISP0F	DISPLAY CONTROL L: OFF H: ON
12	CL2	DATA INPUT CLOCK
13	CL1	INPUT DATA LATCH SIGNAL
14	FLM	SCAN START-UP SIGNAL
15	Vss	GROUND
16	VEE	POWER SUPPLY FOR LCD

SUITABLE CONNECTOR : SM02B-BHSS-1-TB (JST)
CN2 : BHSR-02VS-1(JST) (PIN1-HOT,PIN2-GND)

1	H.V	POWER SUPPLY VOLTAGE FOR CCFL
2	GND	CCFL GND

DETAIL 'A'
(SCALE 40:1)

DIMENSION	TOLERANCE
L ≤ 6	±0.25 (mm)
6 < L ≤ 18	±0.3 (mm)
18 < L ≤ 50	±0.4 (mm)
50 < L ≤ 125	±0.5 (mm)
125 < L	±0.6 (mm)
ANGLE	±1° (DEG)

南亞塑膠工業股份有限公司
NAN YA PLASTICS CORPORATION

製品圖
LCBA7T211M

REV. NO.	DESCRIPTION	DATE	DESIGN	CHECK	APPROVE
1	修改產編	98.08.28	C.CHEN	M.YUIN	M.YUIN
2	配合統結案會議內容要求修改	98.09.05	C.CHEN	M.YUIN	M.YUIN
3	電線出線長度修正	98.03.08	C.CHEN	M.YUIN	TWY.QUU
4	線組厚度修正	94.03.11	Y.HUNG		