

NAN YA PLASTICS CORPORATION

SPECIFICATION OF
 LCD MODULE
 PRODUCT NO.: LCBFBT161_4_

SPEC. NO: LM161-4-1

CUSTOMER
APPROVED BY
DATE:

LCD DEPARTMENT
 ELECTRONIC MATERIALS DIVISION
 NAN YA PLASTICS CORPORATION
 201, TUNG HWA N. ROAD, TAIPEI
 TEL: 886-2-27122211 EXT. 5993~5995
 FAX: 886-2-27178253
 E-mail: lcdsales@npc.com.tw

EDITED ON : MAR. 22, 2000

SALE MANAGER	TECHNICAL APPROVE	DESIGN MANAGER	DESIGN CHECK	DESIGNER

www.DataSheet4U.com

1. MECHANICAL DATA

(1) Product No.	LCBFBI161_4_
(2) Module Size	154.6 (W)mm x 114.8 (H)mm x MAX 15.0 (D)mm
(3) Dot Size	0.09 (W)mm x 0.33 (H)mm
(4) Dot Pitch	0.12 (W)mm x 0.36 (H)mm
(5) Number of Dots	320 (W)xRGB x 240 (H)DOTS
(6) Duty	1/240
(7) LCD	F-STN: Color STN module Rear Polarizer: Color Transmissive Type
(8) Viewing Direction	<input type="checkbox"/> 6 O'clock <input type="checkbox"/> 12 O'clock
(9) Backlight	CCFL
(10) Controller	Excluded
(11) DC/DC Converter	Excluded
(12) Weight	210 g(approx.)

Note :

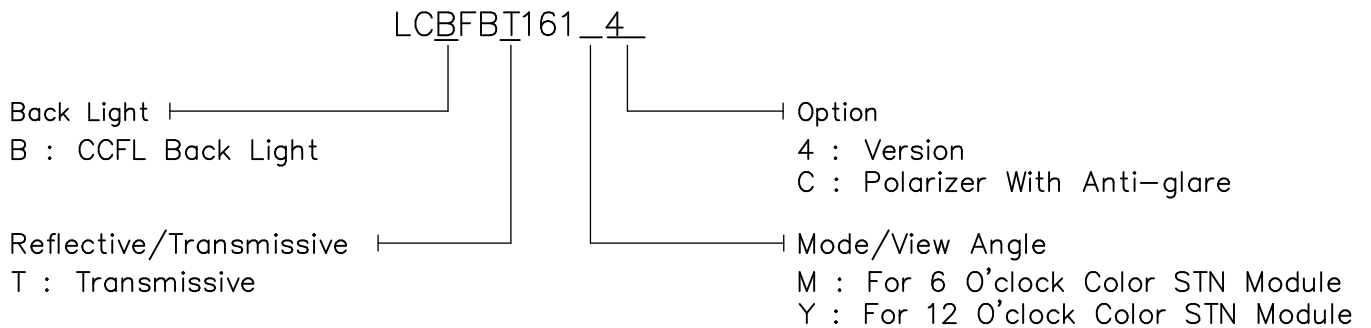

www.DataSheet4U.com

2. ABSOLUTE MAXIMUM RATINGS

(1) ELECTRICAL ABSOLUTE RATINGS

VSS=0V

ITEM	SYMBOL	MIN	MAX	UNIT	COMMENT
Power Supply for Logic	VDD-VSS	-0.3	6.5	V	
Power Supply for LCD Drive	VEE-VSS	0	42.0	V	
Input Voltage	VI	-0.3	VDD+0.3	V	
Static Electricity	-	-	-	-	Note 1

(2) ENVIRONMENTAL ABSOLUTE MAXIMUM RATINGS

ITEM	OPERATING		STORAGE	
	MIN.	MAX.	MIN.	MAX.
Ambient Temperature	0	50	-20	70
Humidity (Without Condensation)	Note 2,4		Note 3,4	
Vibration	Note 5			

Note 1 LCM should be grounded during handling LCM.

Note 2 $T_a \leq 50^\circ\text{C}$: 85%RH max

$T_a > 50^\circ\text{C}$: Absolute humidity must be lower
than the humidity of 85%RH at 50°C

Note 3 T_a at -20°C will be < 48 hrs, at 70°C will be < 120 hrs

Note 4 Background color will change slightly depending on ambient temperature.
That phenomenon is reversible.

Note 5

Frequency	5 Hz~13.95 Hz	13.95 Hz~33 Hz	33 Hz~51 Hz	51 Hz~500 Hz
Vibration Level	-	2X9.8 m/s ²	-	5x9.8 m/s ²
Vibration Width	0.2 inch	-	0.036 inch	-
Vibration Direction	X/Y/Z			
Vibration Time	20 min/cycle X 3 directions			

www.DataSheet4U.com

3. ELECTRICAL CHARACTERISTICS

3-1. ELECTRICAL CHARACTERISTICS OF LCM

Ta=25°C, VDD=5V±5%

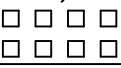
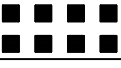
ITEM		SYMBOL	CONDITION	MIN.	TYP.	MAX.	UNIT		
Logic Circuit Power Supply		VDD-VSS	Ta= 25°C	4.75	5.0	5.25	V		
Input Voltage		VIH	H level	0.8VDD	-	VDD	V		
		VIL	L level	0	-	0.2VDD	V		
Recommended LCD Driving Voltage		VEE-VSS (Vop)	Duty=1/240 VDD=5.0V	0°C	26.9	27.2	27.5	V	
				25°C	25.5	25.8	26.1		
				50°C	24.0	24.3	24.6		
Supply Current for Logic		IDD	VDD-VSS=5.0V VEE-VSS=25.8V Ta=25°C	-	6.8	13.0	mA		
Supply Current for LCD		IEE	PATTERN : 	-	11.5	15.0	mA		
LCM	Surface Luminance	L	VDD-VSS =5.0V VEE-VSS =25.8V Ta=25°C IL=5mA	PATTERN: (Dots All On of White Color) 		-	165	-	cd/m ²
				PATTERN: (Dots All Off) 		-	5.3	-	
Recommended Frame Frequency for Optimum Contrast		FLM	-	115	120	125	Hz		

3-2.ELECTRICAL CHARACTERISTICS OF BACKLIGHT

Used lamp : Rating

PARAMETER	SYMBOL	MIN.	TYP.	MAX.	UNIT	REMARK
Lamp Voltage	V _L	-	506	-	V _{rms}	-
Lamp current	I _L	2	5	6	mArms	(*1)
Lamp power consumption	P _L	-	2.53	-	W	(*2)
Lamp frequency	F _L	20	35	50	KHz	
Lamp life time	L _L	-	20000	-	hrs	IL = 5 mArms

(*1) It is recommended that I_L be not more than 5.0 mArms so that heat radiation of CCFT backlight may least affect the display quality .

(*2) Power consumption excluded inverter loss .

4. OPTICAL CHARACTERISTICS

4-1. Optical Char. of Normal Temp. Mode

AT Vop

ITEM MODE		Cr(Contrast Ratio)						θ (Viewing Angle)		ϕ (Viewing Angle)	
		0°C		25°C		50°C		25°		25°	
		MIN.	TYP.	MIN.	TYP.	MIN.	TYP.	MIN.	TYP.	MIN.	TYP.
T	M	-	25	-	40	-	10	-	80	-	±45
NOTE		NOTE 6						NOTE 5			

note:

T: TRANSMISSIVE
M: FOR 6 O'CLOCK STN MODULE

AT $\phi=0^\circ$ $\theta=0^\circ$

ITEM	SYMBOL	CONDITION	MIN.	TYP.	MAX.	UNIT	NOTE
Response Time (rise)	Tr	0°C	-	400	440	ms	NOTE 2
		25°C	-	200	220		
		50°C	-	110	120		
Response Time (fall)	Tf	0°C	-	300	330	ms	NOTE 2
		25°C	-	80	90		
		50°C	-	55	60		

4-2. Color of CIE Coordinate

Ta = 25°C

ITEM		SYMBOL	CONDITION	VALUE	NOTE
Color of CIE Coordinate	Red	X	$\phi=0^\circ, \theta=0^\circ$	0.465	Note*
		y		0.310	
	Green	X	$\phi=0^\circ, \theta=0^\circ$	0.275	
		y		0.516	
	Blue	X	$\phi=0^\circ, \theta=0^\circ$	0.160	
		y		0.120	
	White	X	$\phi=0^\circ, \theta=0^\circ$	0.246	
		y		0.299	

Note* Measuring at position 3 on Fig.1
CIE chromaticity diagram

Tolerance : ± 0.05

Fig.1

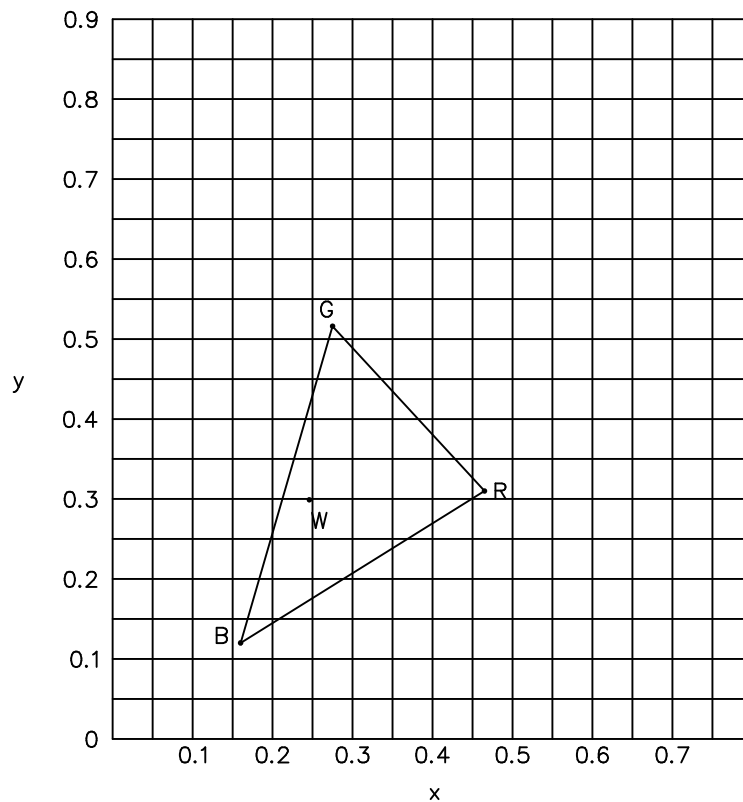

www.DataSheet4U.com

(NOTE 1)

Definition of Operation Voltage(Vop)

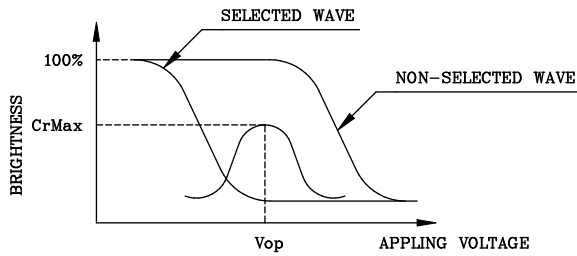

(positive type)

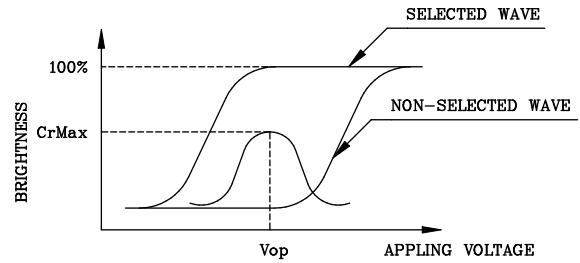

(negative type)

*Conditions

Viewing Angle : 0
 Frame Frequency : 120Hz
 Applying Waveform : 1/N duty 1/a bias

(NOTE 2)

Definition of Response Time(Tr,Tf)

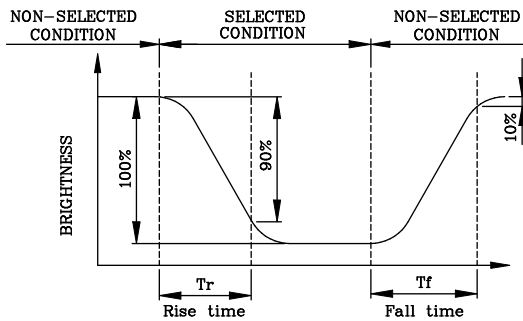

(positive type)

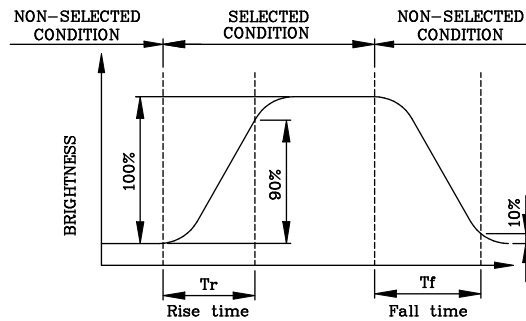

(negative type)

*Conditions

Operating Voltage : Vop
 Viewing Angle (θ,φ) : (0,0)
 Frame Frequency : 120Hz
 Applying Waveform : 1/N duty 1/a bias

(NOTE 3)

Description of Measuring Equipment and Driving Waveforms

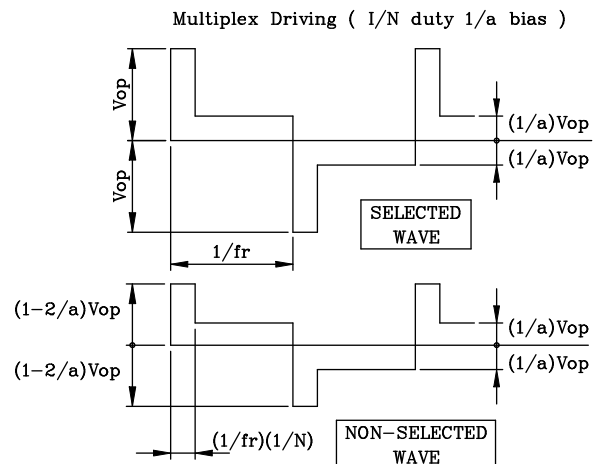
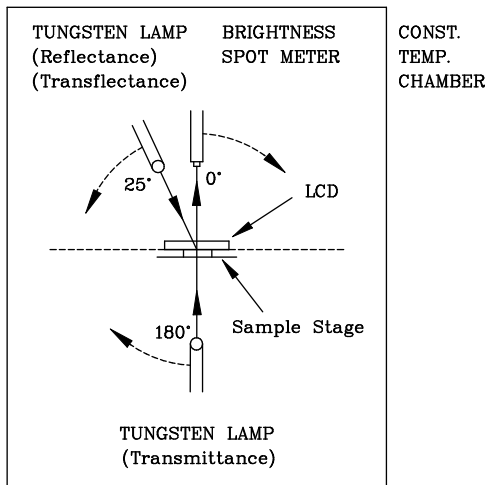

www.DataSheet4U.com

(NOTE 4)

Definition of Viewing Direction

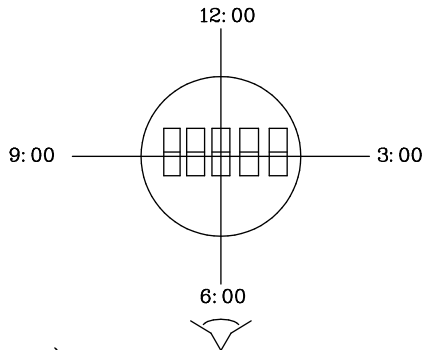

(NOTE 5)

Definition of Viewing Angle

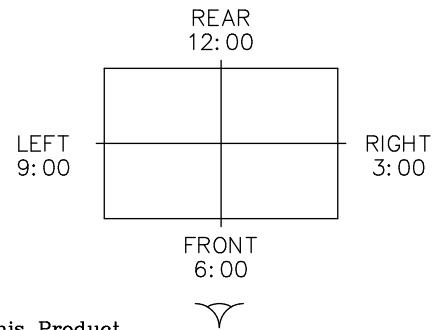
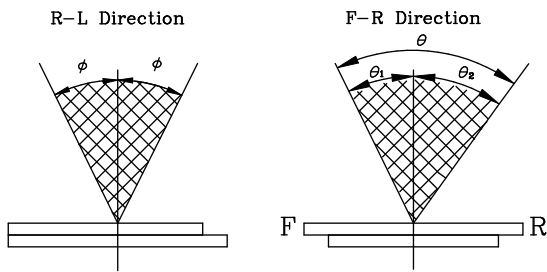

*For This Product
 The Viewing Direction Is 6 O'clock
 So $\theta_1 > \theta_2$

$$\theta = \theta_1 + \theta_2$$

*Conditions

Operating Voltage : V_{op}
 Frame Frequency : 120Hz
 Applying Waveform : 1/N duty 1/a bias
 Contrast Ratio : larger than 2

(NOTE 6)

Definition of Contrast Ratio (Cr)

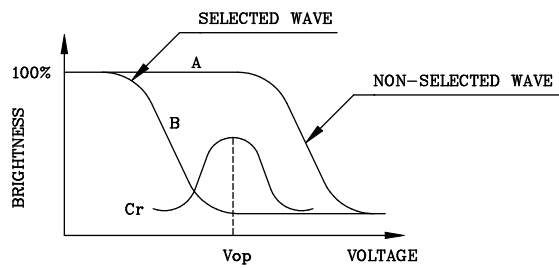

(positive type)

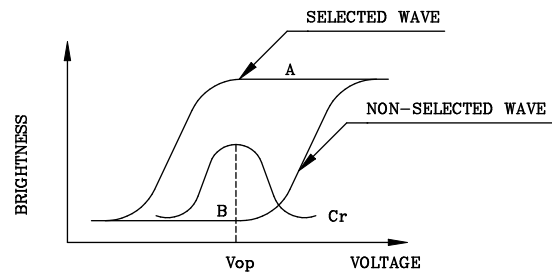

(negative type)

Contrast Ratio : $Cr = A/B$

*Conditions

Viewing Angle : 0
 Frame Frequency : 120Hz
 Applying Waveform : 1/N duty 1/a bias

www.DataSheet4U.com

5. BLOCK DIAGRAM

LCD

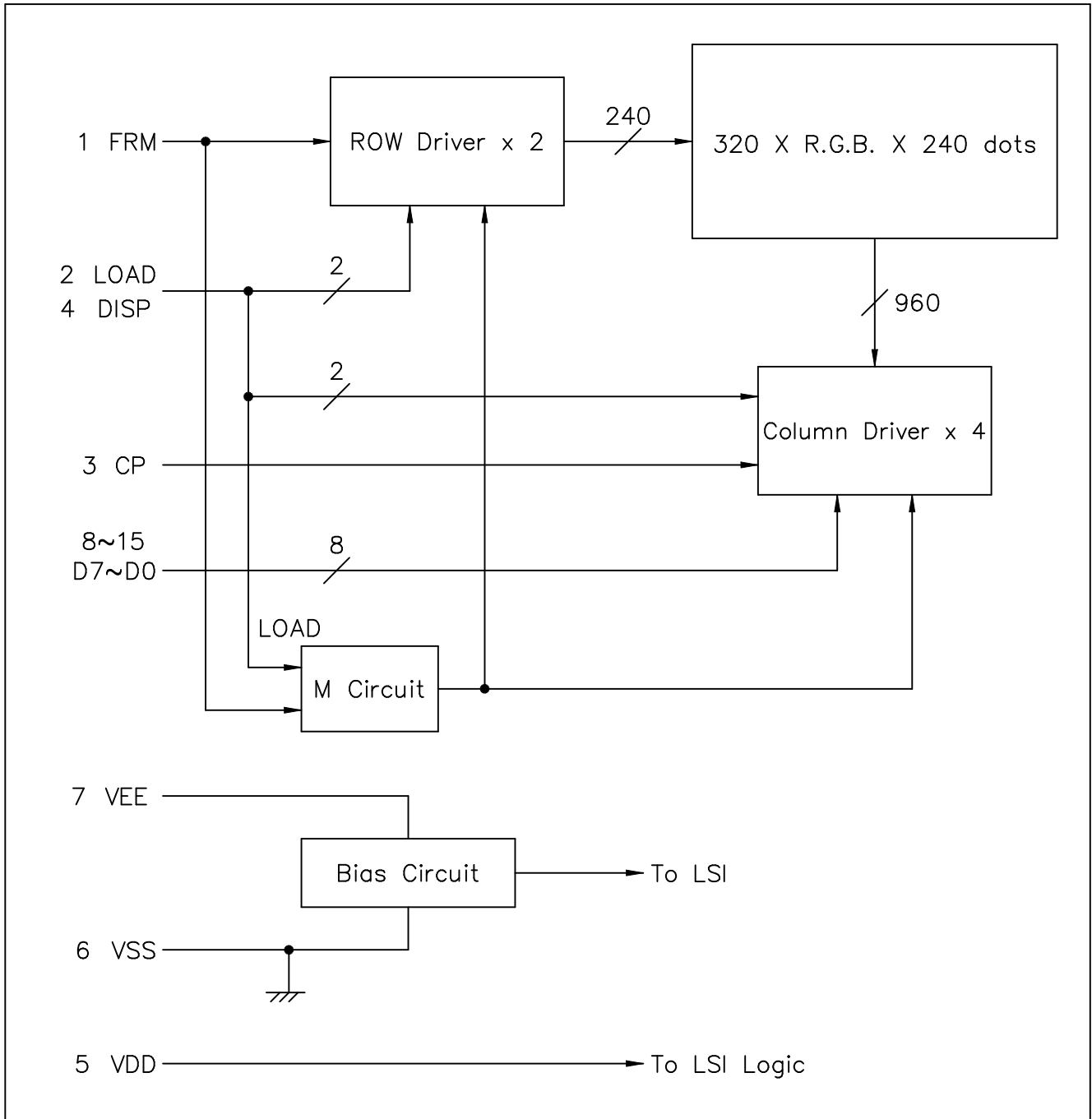

CCFL

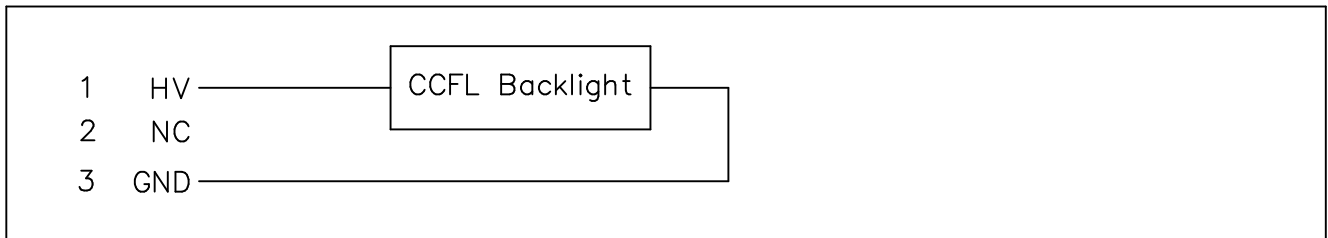

www.DataSheet4U.com

6. INTERNAL PIN CONNECTION

LCD

Pin No.	Symbol	Level	Function
1	FRM	H	Synchronous Signal for Driving Scanning Line
2	LOAD	H→L	Data Signal Latch Clock
3	CP	H→L	Data Signal Shift Clock
4	DISP	H/L	Display Control Signal, H :Display on L :Display off
5	VDD	—	Power Supply for Logic
6	VSS	—	Power Supply (0V,GND)
7	VEE	—	Power Supply for LCD Drive
8	D7	H/L	Display Data
9	D6	H/L	Display Data
10	D5	H/L	Display Data
11	D4	H/L	Display Data
12	D3	H/L	Display Data
13	D2	H/L	Display Data
14	D1	H/L	Display Data
15	D0	H/L	Display Data

CN1 : 53261-1510(Molex)

Recommended Matching Connector : 51021-1500(Molex) or Compatible

CCFL

Pin No.	Symbol	Level	Function
1	HV	AC	Power Supply for CCFL(HOT)
2	NC	—	Non-connection
3	GND	—	Power Supply for CCFL(GND)

CN2 : BHR-03VS-1(JST)

Recommended Matching Connector : SM02-(8.0)B-BHS-1(JST) or Compatible

www.DataSheet4U.com

7. POWER SUPPLY

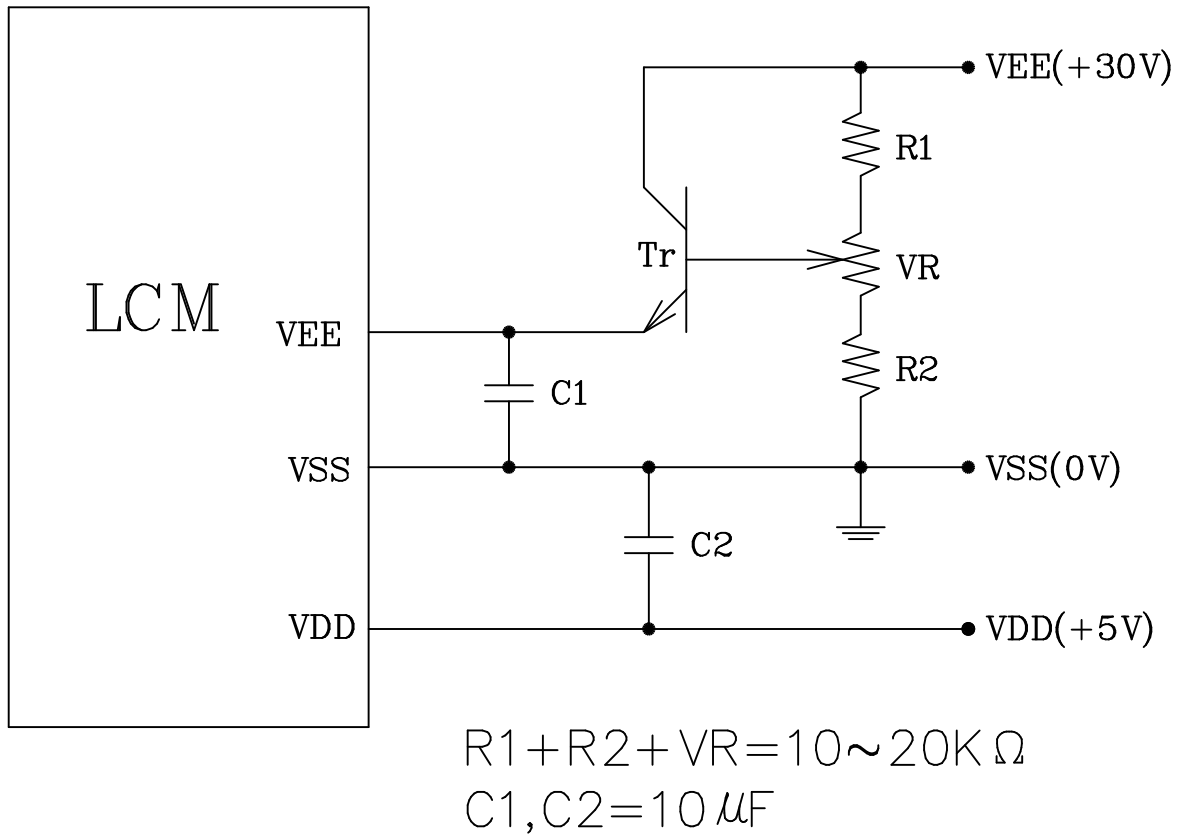

www.DataSheet4U.com

8. TIMING CHARACTERISTICS

8-1. INTERFACE TIMING

VDD=5.0V ± 10%

Parameter	SYMBOL	MIN.	MAX.	UNIT
CLOCK PULSE CYCLE TIME	t_{wck}	50	—	ns
CLOCK PULSE HIGH LEVEL WIDTH	t_{wckH}	15	—	ns
CLOCK PULSE LOW LEVEL WIDTH	t_{wckL}	15	—	ns
LATCH PULSE HIGH LEVEL WIDTH	t_{wLPH}	20	—	ns
CL2→CL1 RISE TIME	t_{LD}	0	—	ns
CL2→CL1 FALL TIME	t_{SL}	25	—	ns
CL1→CL2 RISE TIME	t_{LS}	25	—	ns
CL1→CL2 FALL TIME	t_{LH}	25	—	ns
CLOCK PULSE RISE/FALL TIME	t_r, t_f	—	30	ns
DATA SETUP TIME	t_{DS}	10	—	ns
DATA HOLD TIME	t_{DH}	10	—	ns
FLM SETUP TIME	t_{SU}	100	—	ns
FLM HOLD TIME	t_H	30	—	ns

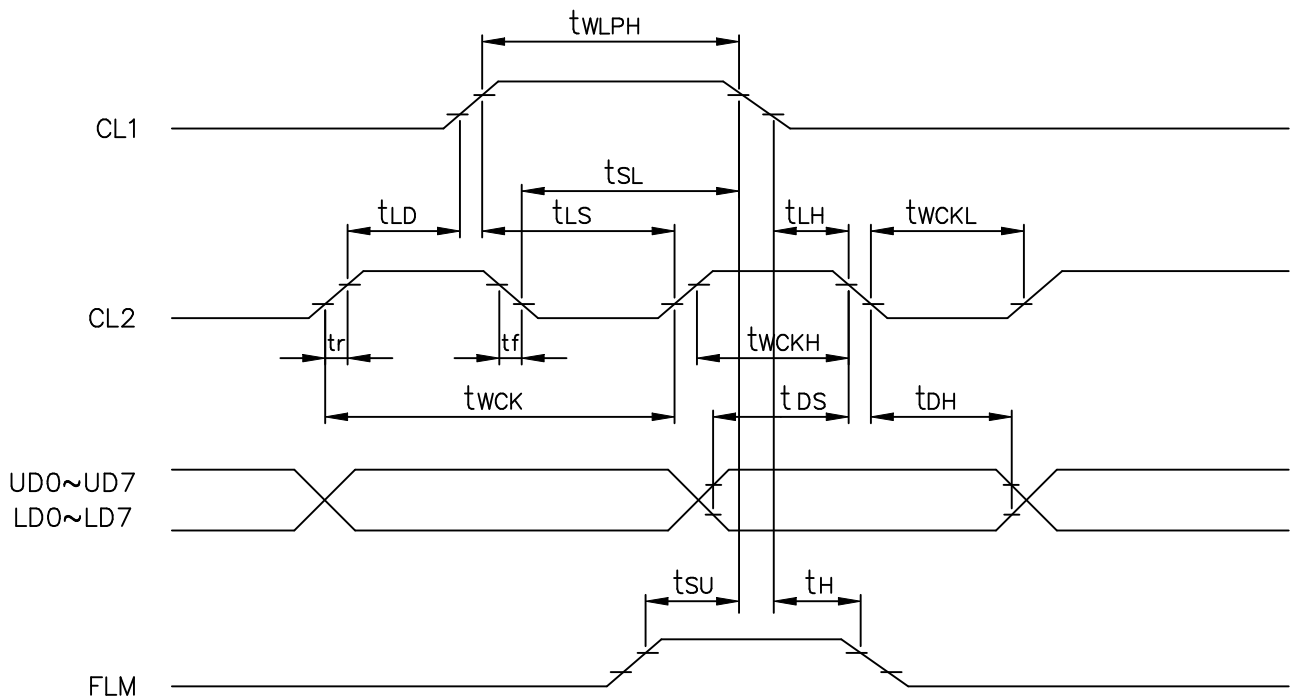

www.DataSheet4U.com

8-2. TIMING CHART

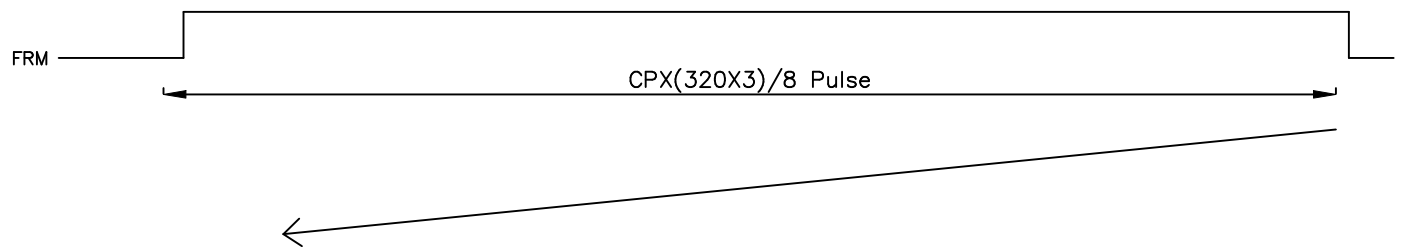
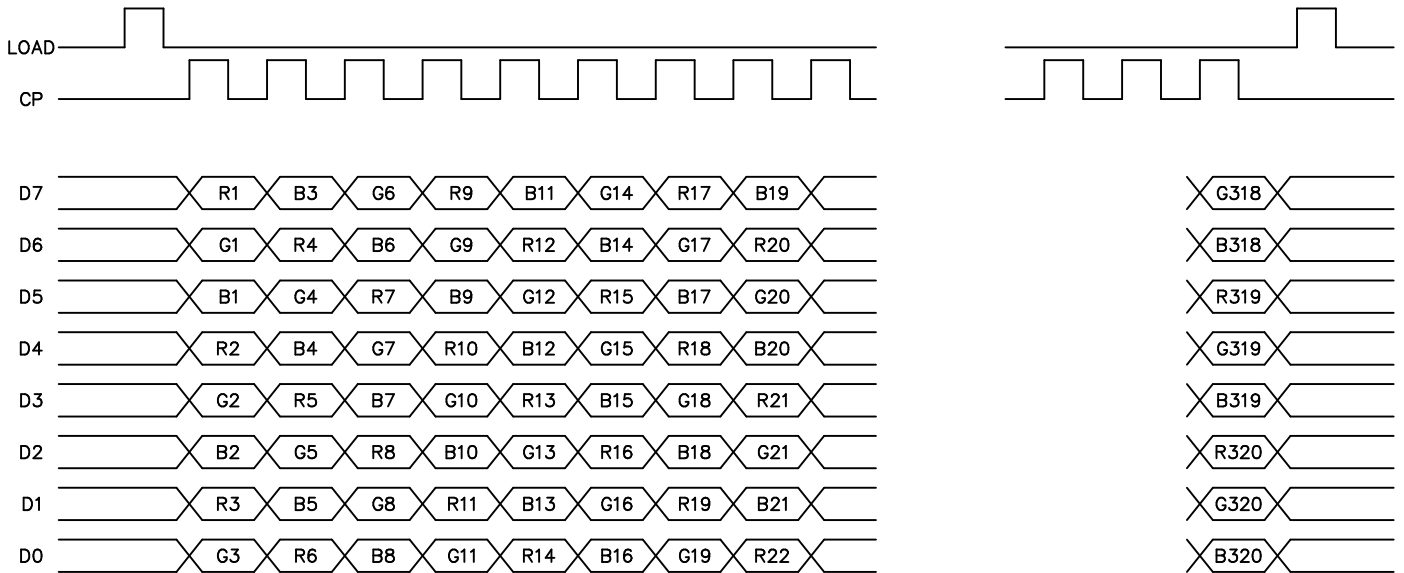

www.DataSheet4U.com

8-3. POWER ON/OFF TIMING

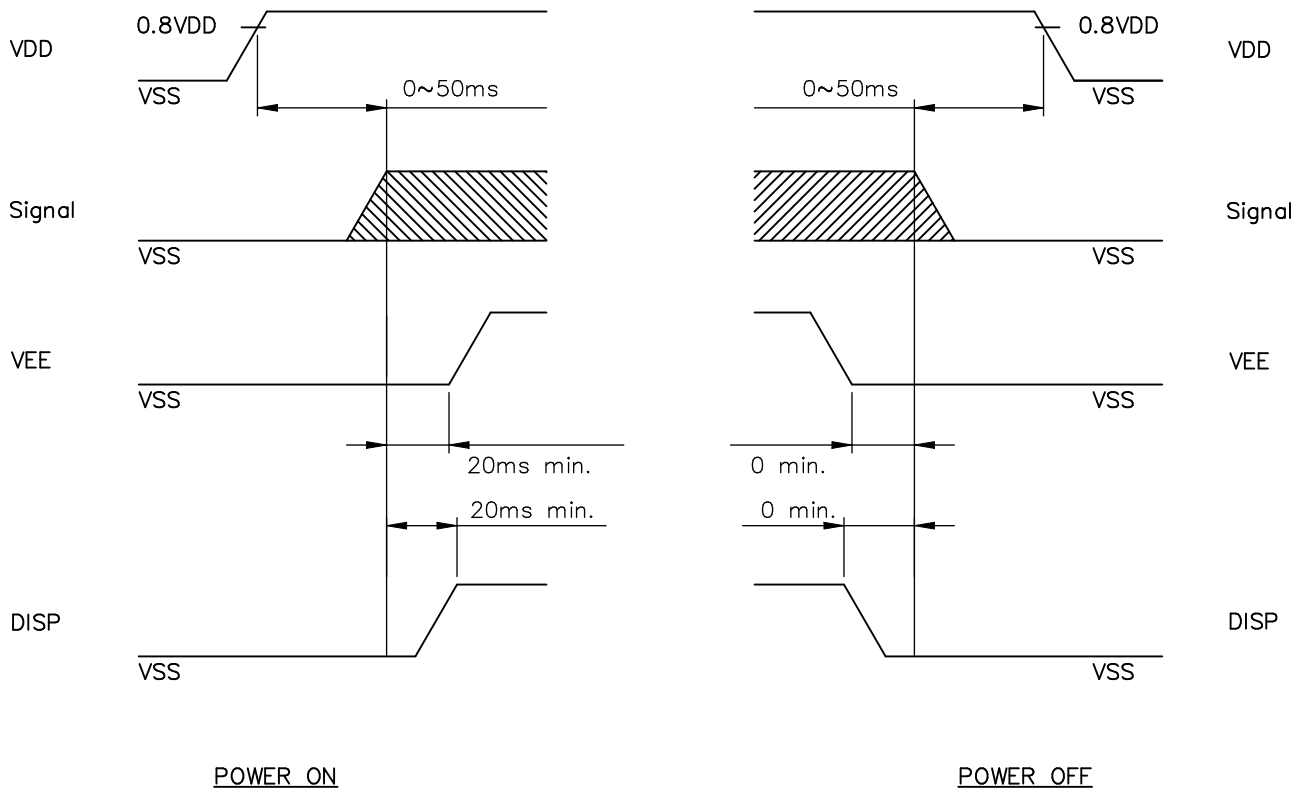

The missing pixels may occur when the LCM is driven beyond above power interface timing sequence.

www.DataSheet4U.com

8-4.DISPLAY PATTERN

START DATA

	Y1			Y2			Y3		
X1	R1	G1	B1	R2	G2	B2	R3	G3	B3
	D7	D6	U5	D4	D3	D2	D1	D0	D7
X2	R1	G1	B1	R2	G2	B2	R3	G3	B3
	D7	D6	U5	D4	D3	D2	D1	D0	D7

Y318			Y319			Y320		
R318	G318	B318	R319	G319	B319	R320	G320	B320
D0	D7	D6	U5	D4	D3	D2	D1	D0
R318	G318	B318	R319	G319	B319	R320	G320	B320
D0	D7	D6	U5	D4	D3	D2	D1	D0

X239	R1	G1	B1	R2	G2	B2	R3	G3	B3
	D7	D6	U5	D4	D3	D2	D1	D0	D7
X240	R1	G1	B1	R2	G2	B2	R3	G3	B3
	D7	D6	U5	D4	D3	D2	D1	D0	D7

R318	G318	B318	R319	G319	B319	R320	G320	B320
D0	D7	D6	U5	D4	D3	D2	D1	D0
R318	G318	B318	R319	G319	B319	R320	G320	B320
D0	D7	D6	U5	D4	D3	D2	D1	D0

www.DataSheet4U.com

9. RELIABILITY TEST

NO	ITEM	CONDITION			STANDARD	NOTE
1	High Temp. Storage	70°C 30%RH	120HR		Appearance without defect	
2	Low Temp. Storage	-20°C	120HR		Appearance without defect	
3	High Temp. & High Humi. Storage	40°C 90%RH	120HR		Appearance without defect	
4	Thermal Shock	-20°C, 30min → R.T. 5min → 70°C, 30min → R.T. 5min (1 cycle)			Appearance without defect	5 cycles

www.DataSheet4U.com

Inspection Provision

1. Purpose

The NAN YA inspection provision provides outgoing inspection provision and its expected quality level based on our outgoing inspection of NAN YA LCD produces.

2. Applicable Scope

The NAN YA inspection provision is applicable to the arrangement in regard to outgoing inspection and quality assurance after outgoing.

3. Technical Terms

3-1 NAN YA Technical Terms

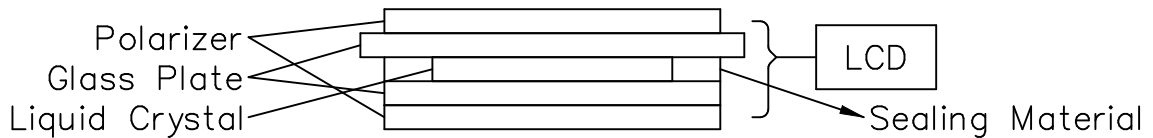

4. Outgoing Inspection Provision

Outgoing inspection is according to the product inspection manual.
(Per 1-1, 1-2 & 1-3)

4-1 Inspection Method

MIL-STD-105D Level II Regular inspection

4-2 Inspection Standard

	Item		AQL(%)	Remarks
Major Defect	Dots	Opens Shorts Erroneous operation	0.4	faults which substantially lower the practicality and the initial purpose difficult to achieve.
	Solder appearance	Shorts Loose		
	Cracks	Display surface cracks		

	Dimensions	External from Dimensions	0.4	
Minor Defect	Inside the glass	Black spots	0.65	faults which appear to pose almost no obstacle to the practicality, effective use, and operation.
	Polarizing plate	Scratches, foreign Matter, air bubbles, and peeling		
	Dots	Pinhole, deformation		
	Color tone	Color unevenness		
	Solder appearance	Cold solder Solder projections		

4-3 Inspection Provisions

*Viewing Area Definition

Fig. 1

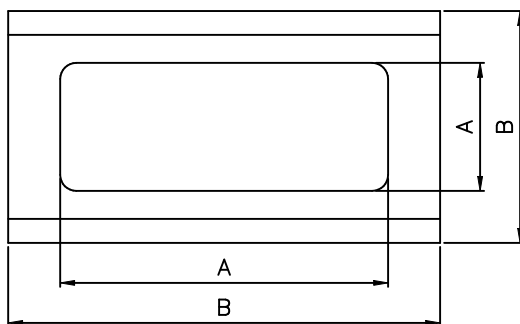

A : Zone Viewing Area
B : Zone Glass Plate Out Line

*Inspection place to be 500 to 1000 lux illuminance uniformly without glaring.

The distance between luminous source(daylight fluorescent lamp and cool white fluorescent lamp) and a sample to be 30cm to 50cm.

www.DataSheet4U.com

*Test and measurement are performed under the following conditions, unless otherwise specified.

Otherwise specified.

Temperature 20± 15°C
Humidity 65± 20%R.H..
Pressure 860~1060hPa(mmbar)

In case of doubtful judgment, it is performed under the following conditions.

Temperature 20± 2°C
Humidity 65± 5%R.H..
Pressure 860~1060hPa(mmbar)

5.Specification for quality check
5-1 Electrical characteristics

NO.	Item	Criterion
1.	Non operational	Fail
2.	Miss operating	Fail
3.	Missing dot	Fail
4.	Contrast irregular	Not allowable
5.	Response time	Within Specified value

5-2 External Appearance Defect

NO.	Item	Criterion																							
1.	Black spots, foreign matter, and white spots (Including light leakage due to pinholes of polarizing plates, etc.)	<p>(1)-1-Spots(At non lighting condition)</p> <table border="1" data-bbox="710 474 1422 810"> <thead> <tr> <th>Average Diameter(mm): D</th> <th>Number of pieces permitted</th> <th>Minimum Space</th> </tr> </thead> <tbody> <tr> <td>$D \leq 0.2$</td> <td>Ignore</td> <td>-</td> </tr> <tr> <td>$0.2 < D \leq 0.3$</td> <td>5</td> <td>10mm</td> </tr> <tr> <td>$0.3 < D \leq 0.4$</td> <td>2</td> <td>30mm</td> </tr> <tr> <td>$0.4 < D$</td> <td>0</td> <td></td> </tr> </tbody> </table> <p>Number of total pieces is set to within 5 pieces.</p> <p>Note that when there are 2 pieces or more, they are not to be concentrated. Set as: Average diameter = (Long diameter + Short diameter)/2</p> <p>(1)-2-Spots(At lighting condition)</p> <table border="1" data-bbox="710 1234 1355 1473"> <thead> <tr> <th>Average Diameter(mm): D</th> <th>Number of pieces permitted</th> </tr> </thead> <tbody> <tr> <td>$D \leq 0.3$</td> <td>Ignore</td> </tr> <tr> <td>$0.3 < D \leq 0.75$</td> <td>5</td> </tr> <tr> <td>$0.75 < D$</td> <td>0</td> </tr> </tbody> </table> <p>Number of total pieces is set to within 5 pieces.</p> <p>Note that when there are 2 pieces or more, they are not to be concentrated. Set as: Average diameter = (Long diameter + Short diameter)/2</p>	Average Diameter(mm): D	Number of pieces permitted	Minimum Space	$D \leq 0.2$	Ignore	-	$0.2 < D \leq 0.3$	5	10mm	$0.3 < D \leq 0.4$	2	30mm	$0.4 < D$	0		Average Diameter(mm): D	Number of pieces permitted	$D \leq 0.3$	Ignore	$0.3 < D \leq 0.75$	5	$0.75 < D$	0
Average Diameter(mm): D	Number of pieces permitted	Minimum Space																							
$D \leq 0.2$	Ignore	-																							
$0.2 < D \leq 0.3$	5	10mm																							
$0.3 < D \leq 0.4$	2	30mm																							
$0.4 < D$	0																								
Average Diameter(mm): D	Number of pieces permitted																								
$D \leq 0.3$	Ignore																								
$0.3 < D \leq 0.75$	5																								
$0.75 < D$	0																								

<p>1. Black spots, foreign matter, and white spots (Including light leakage due to pinholes of polarizing plates, etc.)</p>	<p>(1)-1 Spots(At non lighting condition)</p> <table border="1" data-bbox="710 427 1453 712"> <thead> <tr> <th>Width(mm): W</th> <th>Length(mm):L</th> <th>Number of pieces permitted</th> </tr> </thead> <tbody> <tr> <td>$W \leq 0.03$</td> <td>Ignore</td> <td>Ignore</td> </tr> <tr> <td>$0.03 < W \leq 0.08$</td> <td>$L \leq 4$</td> <td>2</td> </tr> <tr> <td>$0.08 < W \leq 0.1$</td> <td>$L \leq 1$</td> <td>1</td> </tr> </tbody> </table> <p>Object exceeding 0.1mm follow the standards of the spots form. Note that when there are 2 pieces or more, they are not to be concentrated.</p> <p>(1)-2 Spots(At lighting condition)</p> <table border="1" data-bbox="710 1016 1453 1301"> <thead> <tr> <th>Width(mm): W</th> <th>Length(mm):L</th> <th>Number of pieces permitted</th> </tr> </thead> <tbody> <tr> <td>$W \leq 0.03$</td> <td>Ignore</td> <td>Ignore</td> </tr> <tr> <td>$0.03 < W \leq 0.08$</td> <td>$L \leq 3$</td> <td>6</td> </tr> <tr> <td>$0.08 < W$</td> <td>$3 < L$</td> <td>None</td> </tr> </tbody> </table> <p>Object exceeding 0.1mm follow the standards of the spots form. Note that when there are 2 pieces or more, they are not to be concentrated.</p>	Width(mm): W	Length(mm):L	Number of pieces permitted	$W \leq 0.03$	Ignore	Ignore	$0.03 < W \leq 0.08$	$L \leq 4$	2	$0.08 < W \leq 0.1$	$L \leq 1$	1	Width(mm): W	Length(mm):L	Number of pieces permitted	$W \leq 0.03$	Ignore	Ignore	$0.03 < W \leq 0.08$	$L \leq 3$	6	$0.08 < W$	$3 < L$	None
Width(mm): W	Length(mm):L	Number of pieces permitted																							
$W \leq 0.03$	Ignore	Ignore																							
$0.03 < W \leq 0.08$	$L \leq 4$	2																							
$0.08 < W \leq 0.1$	$L \leq 1$	1																							
Width(mm): W	Length(mm):L	Number of pieces permitted																							
$W \leq 0.03$	Ignore	Ignore																							
$0.03 < W \leq 0.08$	$L \leq 3$	6																							
$0.08 < W$	$3 < L$	None																							
<p>2. Scratches(Glass, reflection plates, and polarizing plates)</p>	<p>In accordance with black spots. (At non lighting condition)</p>																								
<p>3. Color irregular</p>	<p>Not remarkable color irregular.</p>																								

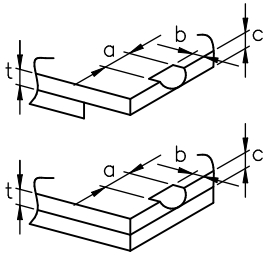
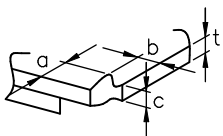
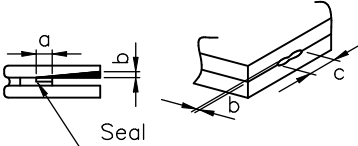
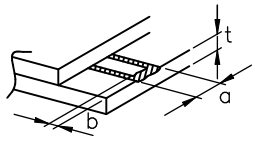
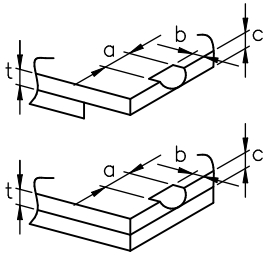
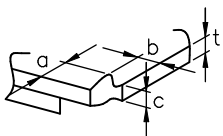
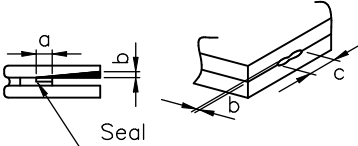
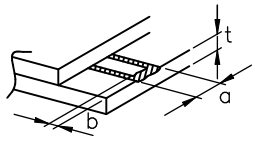
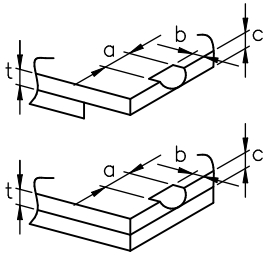
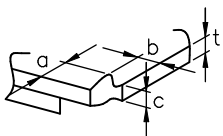
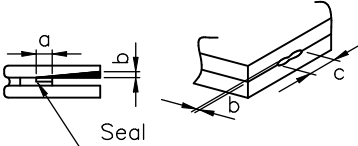
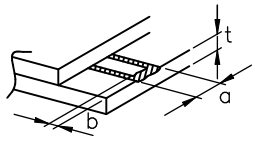
<p>4. Air bubbles polarizing plates, and reflection plates</p>	<table border="1" data-bbox="710 376 1225 667"> <tr> <th data-bbox="710 376 970 521">Average Diameter (mm):D</th> <th data-bbox="970 376 1225 521">Number of pieces permitted</th> <th data-bbox="1225 376 1476 667" rowspan="2">Average diameter = (Long diameter + Short diameter)/2</th> </tr> <tr> <td data-bbox="710 521 970 667">D ≤ 0.3 0.3 < D</td> <td data-bbox="970 521 1225 667">Ignore 0</td> </tr> </table> <p data-bbox="710 683 1476 779">Note that when there are 4 pieces or more, they are not to be concentrated.</p>		Average Diameter (mm):D	Number of pieces permitted	Average diameter = (Long diameter + Short diameter)/2	D ≤ 0.3 0.3 < D	Ignore 0					
Average Diameter (mm):D	Number of pieces permitted	Average diameter = (Long diameter + Short diameter)/2										
D ≤ 0.3 0.3 < D	Ignore 0											
<p>5. Cracks</p>	<table border="1" data-bbox="662 779 1476 1964"> <tr> <td data-bbox="662 779 1066 1169"> <p>(1) General crack</p>  </td> <td data-bbox="1066 779 1476 1169"> <p>a ≤ 5 b ≤ 2 c ≤ t</p> <p>Where, a and b are ignored when less than or equal 0.5. The numbers of pieces are set at up to 5 pieces.</p> </td> </tr> <tr> <td data-bbox="662 1169 1066 1361"> <p>(2) Corner crack</p>  </td> <td data-bbox="1066 1169 1476 1361"> <p>a ≤ 2.5 b ≤ 2.5 c ≤ t a + b ≤ 4</p> </td> </tr> <tr> <td data-bbox="662 1361 1066 1630"> <p>(3) Seal portion crack</p>  </td> <td data-bbox="1066 1361 1476 1630"> <p>a ≤ The seal width × 1/3 b ≤ t × 2/3 c ≤ 5</p> <p>The numbers of pieces are set at up to 5 pieces.</p> </td> </tr> <tr> <td data-bbox="662 1630 1066 1870"> <p>(4) ITO Pin crack</p>  </td> <td data-bbox="1066 1630 1476 1870"> <p>a ≤ 5 b ≤ 1/3 pin length c ≤ t</p> </td> </tr> <tr> <td data-bbox="662 1870 1066 1964"> <p>(5) Progressive cracks</p> </td> <td data-bbox="1066 1870 1476 1964"> <p>All taken to be unacceptable.</p> </td> </tr> </table>		<p>(1) General crack</p> 	<p>a ≤ 5 b ≤ 2 c ≤ t</p> <p>Where, a and b are ignored when less than or equal 0.5. The numbers of pieces are set at up to 5 pieces.</p>	<p>(2) Corner crack</p> 	<p>a ≤ 2.5 b ≤ 2.5 c ≤ t a + b ≤ 4</p>	<p>(3) Seal portion crack</p> 	<p>a ≤ The seal width × 1/3 b ≤ t × 2/3 c ≤ 5</p> <p>The numbers of pieces are set at up to 5 pieces.</p>	<p>(4) ITO Pin crack</p> 	<p>a ≤ 5 b ≤ 1/3 pin length c ≤ t</p>	<p>(5) Progressive cracks</p>	<p>All taken to be unacceptable.</p>
<p>(1) General crack</p> 	<p>a ≤ 5 b ≤ 2 c ≤ t</p> <p>Where, a and b are ignored when less than or equal 0.5. The numbers of pieces are set at up to 5 pieces.</p>											
<p>(2) Corner crack</p> 	<p>a ≤ 2.5 b ≤ 2.5 c ≤ t a + b ≤ 4</p>											
<p>(3) Seal portion crack</p> 	<p>a ≤ The seal width × 1/3 b ≤ t × 2/3 c ≤ 5</p> <p>The numbers of pieces are set at up to 5 pieces.</p>											
<p>(4) ITO Pin crack</p> 	<p>a ≤ 5 b ≤ 1/3 pin length c ≤ t</p>											
<p>(5) Progressive cracks</p>	<p>All taken to be unacceptable.</p>											

6.	Outer dimensions	Should be with in the tolerance.
7.	Newton ring	Orbicular of interference fringes. To be non. In case of doubtful judgenemt, agreement shall be reachment.
8.	Soldering	Should be no defective soldering such as shorting, loose terminal cold solder, peeling of printed circuit board pattern, improper mouting position, etc.

5-3 Dot Appearance Defect

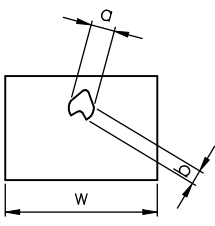
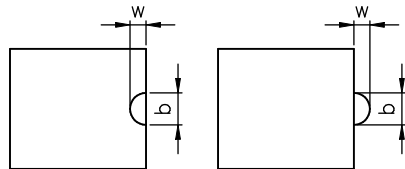
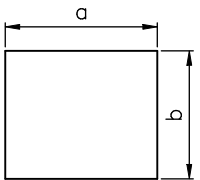
NO.	Item	Criteria
1.	Plinhole	 <p>Dot display a and b are each $\leq 0.2\text{mm}$ The overall total is taken be with in 10 units. Note that they are not to be concentrated.</p>
2.	Missing	 <p>Dot display a and b are each $\leq 0.2\text{mm}$ The overall total is taken to be with in 10 units.</p>
3.	Thick and thin display	 <p>Taken to be within $\pm 1.5\%$ of display character width(a) and height(b).</p>

NOTE:

- SAFETY
 - 1.If the LCD panel breaks, be careful not to get the liquid crystal to touch your skin.
 - 2.If the liquid crystal touches your skin or clothes, please wash it off immediately by using soap and water.

- HANDLING
 - 1.Avoid static electricity which can damage the CMOS LSI.
 - 2.Do not remove the panel or frame from the module.
 - 3.The polarizing plate of the display is very fragile. So, please handle it very carefully.
 - 4.Do not wipe the polarizing plate with a dry cloth, as it may easily scratch the surface of plate.
 - 5.Do not use ketonics solvent & Aromatic solvent, use with a soft cloth soaked with a cleaning naphtha solvent.

- STORAGE
 - 1.Store the panel or module in a dark place where the temperature is $25^{\circ}\text{C}\pm 5^{\circ}\text{C}$ and the humidity is below 65% RH.
 - 2.Do not place the module near organics solvents or corrosive gases.
 - 3.Do not crush, shake, or jolt the module.

- TERMS OF WARRANT
 - 1.Acceptance inspection period
The period is within one month after the arrival of contracted commodity at the buyer's factory site.
 - 2.Applicable warrant period
The period is within twelve months since the date of shipping out under normal using and storage conditions.

- THE OPERATING LIFE TIME OF BACK LIGHT
CCFT : 20,000hrs for lamp-current 5mA, 35KHz, 25°C
(Operating life time is defined as follows : The final brightness is at 50% of original brightness.)

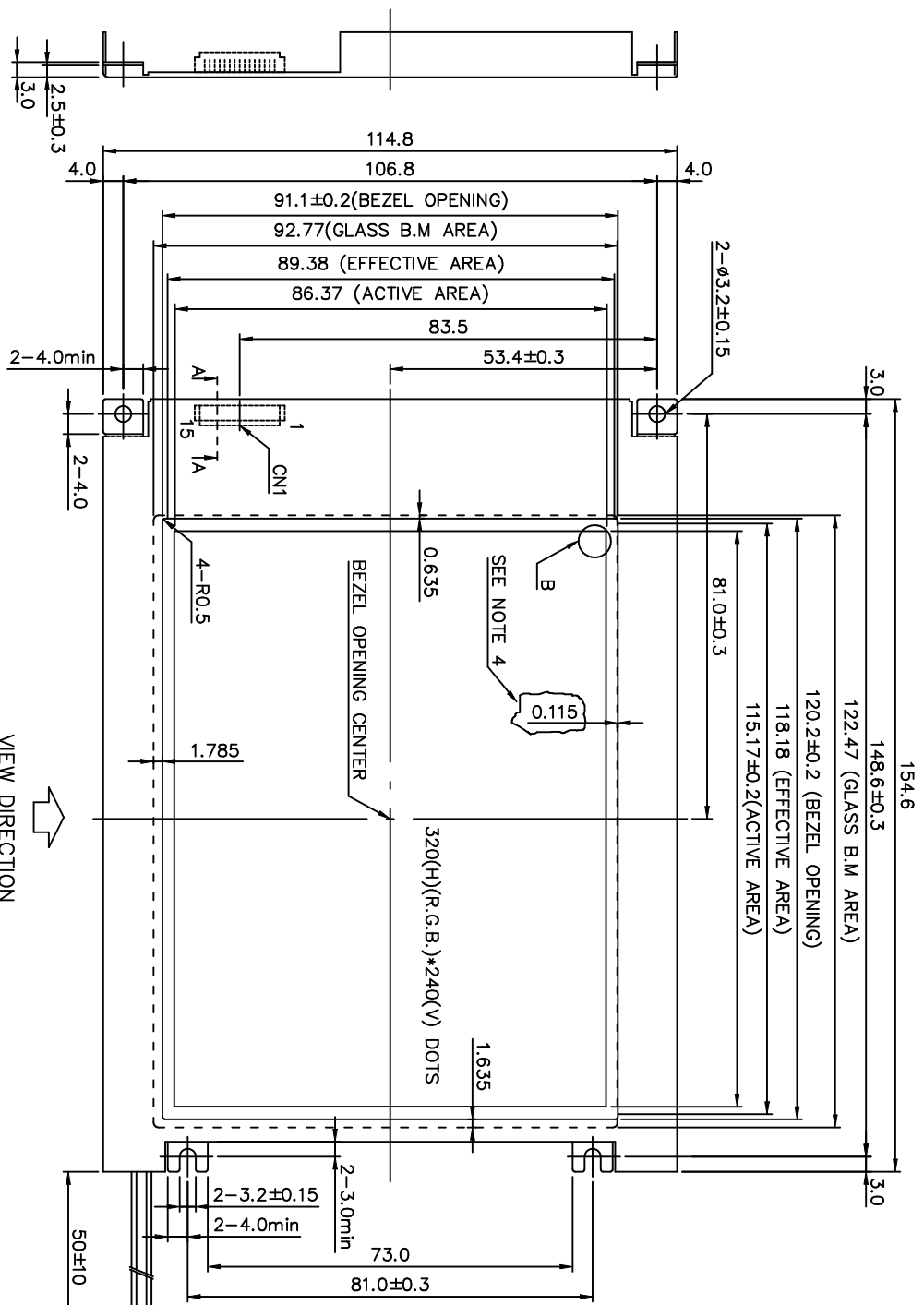

VIEW DIRECTION

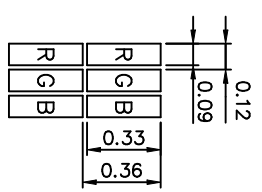
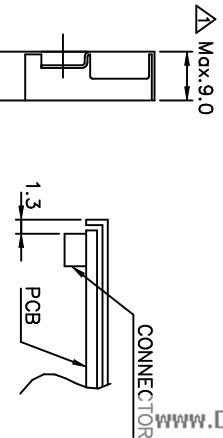
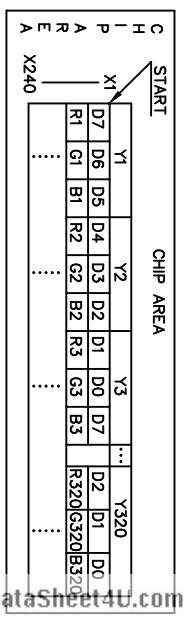

- NOTES:
- 1.RESOLUTION: 320(H)(R.G.B.)X240(V) DOTS
 - 2.BACKLIGHT: CCFL
 - 3.FRAME MATERIAL: SECC (t=0.5)
 - #4. □ 表示處玻璃有漏光現象

GENERAL TOLERANCE LIST

DIMENSION	TOLERANCE
L ≤ 6	±0.25 (mm)
6 < L ≤ 18	±0.3 (mm)
18 < L ≤ 50	±0.4 (mm)
50 < L ≤ 125	±0.5 (mm)
125 < L	±0.6 (mm)
ANGLE	±1° (DEG)

CN1 : 53261-1510 (Molex)

PIN NO	SYMBOL	FUNCTION	LEVEL	10	D5	Display data	LEVEL
1	FRM	Synchronous signal for driving scanning line	H	11	D4	H(ON),L(OFF)	
2	LOAD	Data signal latch clock	H → L	12	D3		
3	CP	Data signal shift clock	H → L	13	D2		
4	DISP	Display control signal	H(ON),L(OFF)	14	D1		
5	VDD	Power supply for logic	-	15	D0		
6	VSS	GND	-	CN2 : BHR-03VS-1 (JST)			
7	VEE	Power supply for LCD	-	PIN NO SYMBOL FUNCTION LEVEL			
8	D7	Display data	H(ON),L(OFF)	1	HV	Power supply for CFL	AC
9	D6	Display data	H(ON),L(OFF)	2	NC	Display data	-
				3	GND	Ground line (from inverter)	-

REV. NO.	DESCRIPTION	DATE	DESIGN	CHECK	APPROVE
1	機殼外觀圖面變更	98.03.22	J.Y. Lin		

南亞塑膠工業股份有限公司
NAN YA PLASTICS CORPORATION

製 品 圖

LCBFBT161X4X

NAME	DATE	THIRD ANGLE P.
APPROVE Tony Chou	98.07.26	
CHECK L.C.WU	98.07.26	
DESIGN Y.C. LIU	98.07.26	
DRAWN Y.C. LIU	98.07.26	

DWG NO. M161-D4A