

NAN YA PLASTICS CORPORATION

SPECIFICATION OF
LCD MODULE
PRODUCT NO.: LCBFBTB61M70S

SPEC. NO.: LMB61-70A- \triangle 1

CUSTOMER
APPROVED BY
DATE:

LCD DEPARTMENT
ELECTRONIC MATERIALS DIVISION
NAN YA PLASTICS CORPORATION
201, TUNG HWA N. ROAD, TAIPEI
TEL: 886-2-27122211 EXT. 5993~5995
FAX: 886-2-27178253
E-mail: lcdsales@npc.com.tw

EDITED ON : Dec. 11. 2007

Q.C. DEPT.	DESIGN MANAGER	DESIGN CHECK	DESIGNER
			W. R. HSU

1. MECHANICAL DATA

NO	ITEM	CONTENTS	UNIT
1	Product No.	LCBFBTB61M70S	-
2	Module Size	154.6 (W) x 114.8 (H) x 9.0 (D)	mm
3	Dot Size	0.10 (W) x 0.34 (H)	mm
4	Dot Pitch	0.12 (W) x 0.36 (H)	mm
5	Number of Dots	320 x RGB (W) x 240 (H)	Dot
6	Duty	1/240	-
7	LCD Display Mode	FSTN, Color STN Module	-
8	Rear Polarizer	Color Transmissive Type	-
9	Viewing Direction	6	O'clock
10	Backlight	CCFL	-
11	Controller	Excluded	-
12	DC/DC Converter	Included	-
13	Weight	195 g(approx.)	g

Note :

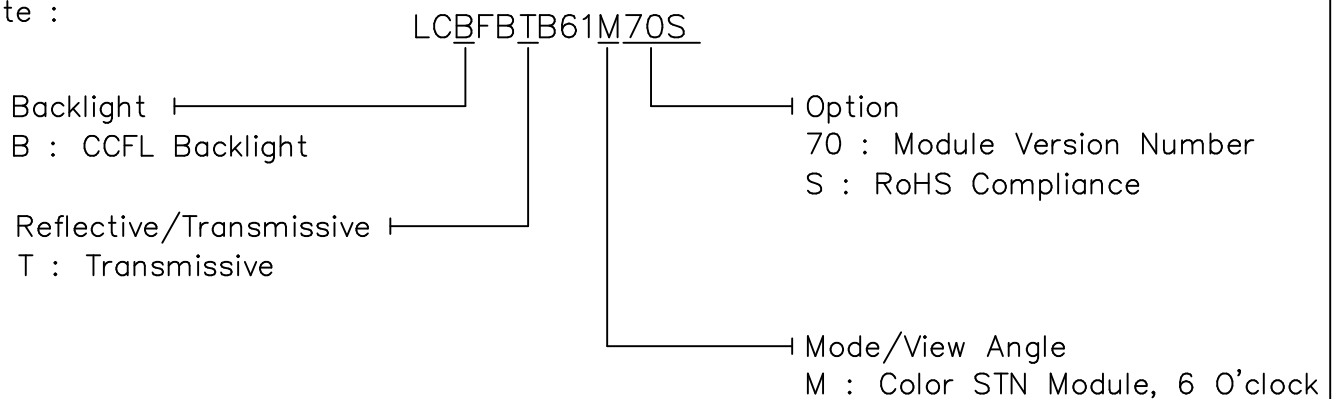

RoHS Compliance.

Nan Ya guarantees that this project doesn't include any materials (6 materials) or includes less than specified quantities which are regulated by RoHS Compliance.

2. ABSOLUTE MAXIMUM RATINGS

(1) ELECTRICAL ABSOLUTE RATINGS

VSS=0V

	SYMBOL	MIN.	MAX.	UNIT	COMMENT
Power Supply for Logic	VDD-VSS	-0.3	5.5	V	
Input Voltage	VI	-0.3	VDD	V	
Contrast Adjust Voltage	VEE-VSS	1.5	2.5	V	
Static Electricity	-	-	-	-	Note 1

Note 1 LCM should be grounded during handling LCM.

(2) ENVIRONMENTAL ABSOLUTE MAXIMUM RATINGS

ITEM	NORMAL TEMP.			
	OPERATING		STORAGE	
	MIN.	MAX.	MIN.	MAX.
Ambient Temperature	0	50	-20	70
Humidity (Without Condensation)	Note 2,4		Note 3,4	

Note 2 $T_a \leq 50^\circ\text{C}$: 80%RH max

Note 3 Please refer to item of reliability test

Note 4 Background color will change slightly depending on ambient temperature.

That phenomenon is reversible.

3. ELECTRICAL CHARACTERISTICS

3-1. ELECTRICAL CHARACTERISTICS OF LCM

ITEM	SYMBOL	CONDITION		MIN.	TYP.	MAX.	UNIT
Logic Circuit Power Supply	VDD-VSS	Ta= 25°C		4.5	5.0	5.5	V
				3.0	3.3	3.6	
Input Voltage	VIH	H level		0.8VDD	-	VDD	V
	VIL	L level		0	-	0.2VDD	V
Contrast Adjust Voltage	VEE-VSS	Duty=1/240 Bias=1/13 VDD=3.3/5.0V	0°C 50°C	1.5	1.8	2.5	v
Supply Current for Logic	IDD	VDD-VSS = 3.3V VEE-VSS = 2.0V Ta= 25°C PATTERN: □ ■ □ ■ □ ■ □ ■ ■ □ ■ □ ■ □ ■ □		-	50	100	mA
Supply Current for Logic	IDD	VDD-VSS = 5.0V VEE-VSS = 2.0V Ta= 25°C PATTERN: □ ■ □ ■ □ ■ □ ■ ■ □ ■ □ ■ □ ■ □		-	80	120	mA
LCM	Surface Luminance	L	PATTERN: (Dots All On of White Color)	140	180	-	cd/m ²
			PATTERN: (Dots All Off)	-	11	-	

3-2.ELECTRICAL CHARACTERISTICS OF BACKLIGHT

Used Lamp Rating

Temp.=25°C

ITEM	SYMBOL	MIN.	TYP.	MAX.	UNIT	REMARK
Lamp Voltage	V_L	-	479	-	Vrms	-
Lamp current	I_L	-	5	-	mArms	-
Lamp power consumption	P_L	-	2.4	-	W	(*1)
Starting voltage	V_s	-	-	730	Vrms	Ta=25°C
		-	-	1010	Vrms	Ta=0°C
Lamp life time	L_L	20000	-	-	hrs	at $I_L = 5$ mArms Ta=25°C (*2)

(*1) Power consumption excluded inverter loss .

(*2) Lamp life time is defined as follows : The final brightness is at 50% of original brightness

3-3.ELECTRICAL CHARACTERISTICS OF RECOMMENDED INVERTER TDK TAD250

3-3-1 GENERAL SPECIFICATIONS

OPERATION TEMPERATURE : 00°C~50°C

STORAGE TEMPERATURE : -20°C~80°C

DIMENSION : 95.0(L)mm x 19.5(W)mm x MAX 8.8(H)mm

3-3-2 PIN ASSIGNMENTS

INPUT (CP1) CONNECTOR :
MOLEX 53261-0590

OUTPUT (CP2) CONNECTOR :
MITSUMI M60-04-30-134P

NO.	FUNCTION
1	VIN
2	GND
3	Vrmt ON/OFF CONTROL
4	Vctrl
5	N.C

NO.	FUNCTION
1	RTN
2	N.C
3	N.C
4	HV

3-3-3 RELATIONSHIP BETWEEN VIN & TUBE CURRENT

ITEM	SYMBOL	MIN.	TYP.	MAX.	UNIT	REMARK
Input Voltage	VIN	10	12	15	V	
Control Terminal Input Voltage	Vrmt	3.5	5	10	V	ON State
		-0.5	0	0.4		OFF State
Tube Current Control Voltage	Vctrl	-	1.2	-	V	
Tube Current	IL	-	5	-	mA	

4. OPTICAL CHARACTERISTICS

4-1. Optical Char. of Normal Temp. Mode

AT Vop

ITEM MODE		Cr(Contrast Ratio)						θ (Viewing Angle)		ϕ (Viewing Angle)	
		0°C		25°C		50°C		25°C		25°C	
		MIN.	TYP.	MIN.	TYP.	MIN.	TYP.	MIN.	TYP.	MIN.	TYP.
T	M	20	30	25	35	5	6	-	F: >60 R: 30	-	L: 50 R: 50
NOTE		NOTE 6						NOTE 5			

note:

T: Transmissive

M: For 6 O'clock STN Module

AT $\phi=0^\circ$ $\theta=0^\circ$

ITEM	SYMBOL	CONDITION	MIN.	TYP.	MAX.	UNIT	NOTE
Response Time (rise)	Tr	0°C	300	550	800	ms	NOTE 2
		25°C	110	220	330		
		50°C	50	100	150		
Response Time (fall)	Tf	0°C	130	250	370	ms	NOTE 2
		25°C	40	80	120		
		50°C	30	55	80		

4-2. Color of CIE Coordinate

Ta = 25°C

ITEM		SYMBOL	CONDITION	VALUE	NOTE
Color of CIE Coordinate	Red	X	$\phi=0^\circ, \theta=0^\circ$	0.55	Note*
		y		0.33	
	Green	X	$\phi=0^\circ, \theta=0^\circ$	0.30	
		y		0.52	
	Blue	X	$\phi=0^\circ, \theta=0^\circ$	0.16	
		y		0.12	
	White	X	$\phi=0^\circ, \theta=0^\circ$	0.30	
		y		0.32	

Note* Measuring at position 3 on Fig.1
CIE chromaticity diagram

Tolerance : ± 0.05

Fig.1

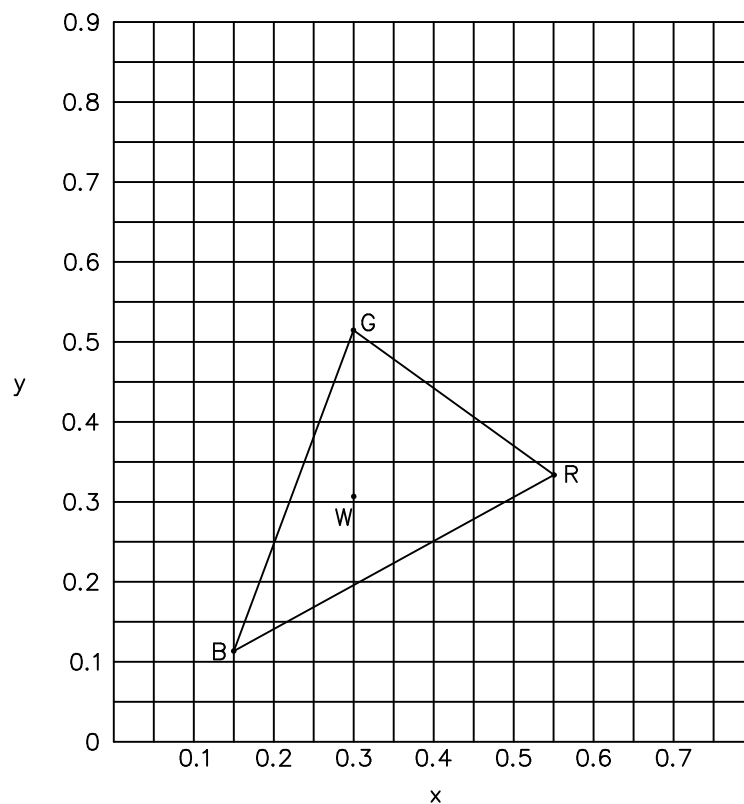

(NOTE 1)

Definition of Operation Voltage(Vop)

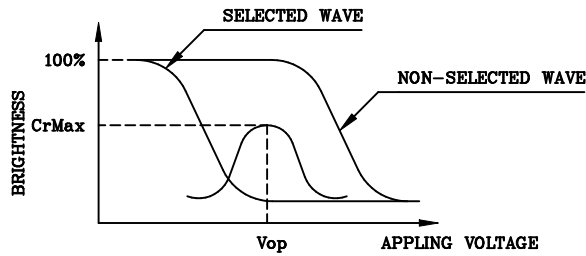

(positive type)

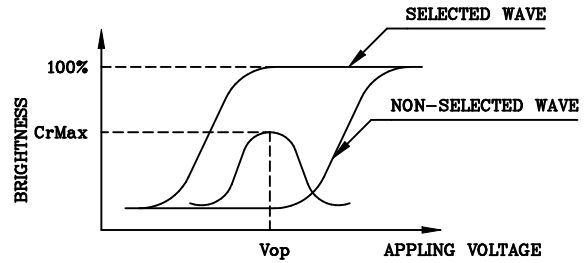

(negative type)

*Conditions

Viewing Angle : 0
Frame Frequency : 120Hz
Applying Waveform : 1/N duty 1/a bias

(NOTE 2)

Definition of Response Time(Tr,Tf)

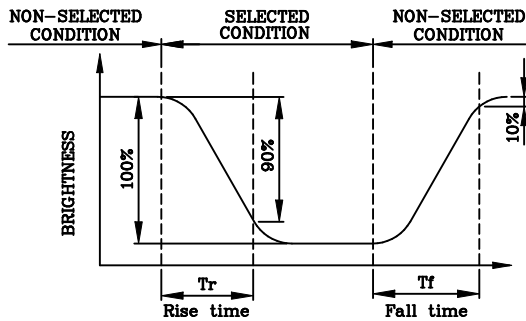

(positive type)

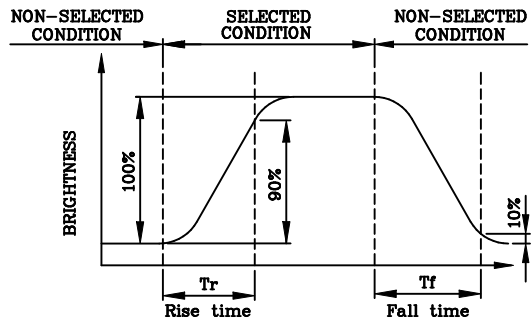

(negative type)

*Conditions

Operating Voltage : Vop
Viewing Angle (θ,φ) : (0,0)
Frame Frequency : 120Hz
Applying Waveform : 1/N duty 1/a bias

(NOTE 3)

Description of Measuring Equipment and Driving Waveforms

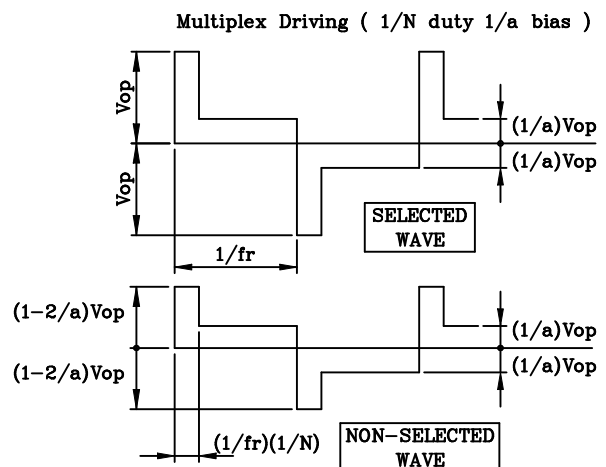
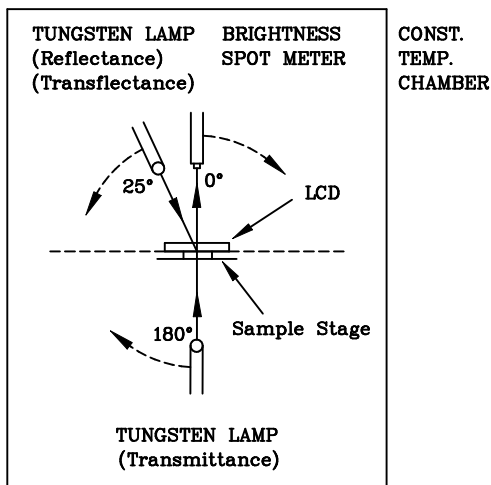

(NOTE 4)

Definition of Viewing Direction

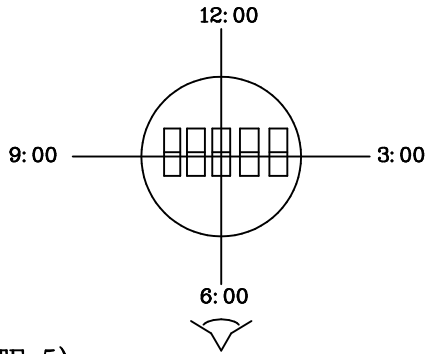

(NOTE 5)

Definition of Viewing Angle

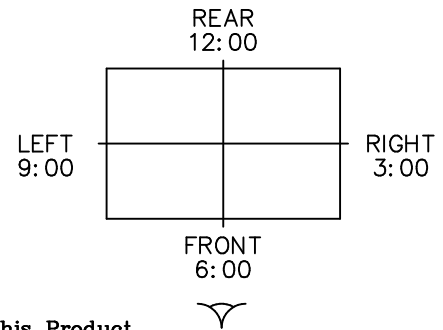
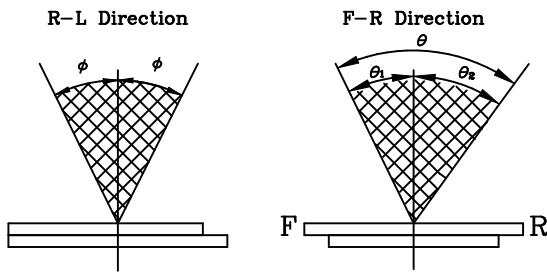

*For This Product
 The Viewing Direction Is 6 O'clock
 So $\theta_1 > \theta_2$

$$\theta = \theta_1 + \theta_2$$

*Conditions

Operating Voltage : V_{op}
 Frame Frequency : 120Hz
 Applying Waveform : 1/N duty 1/a bias
 Contrast Ratio : larger than 2

(NOTE 6)

Definition of Contrast Ratio (Cr)

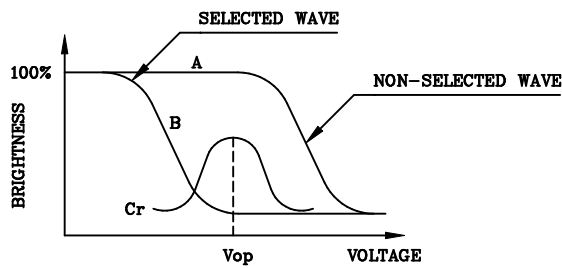

(positive type)

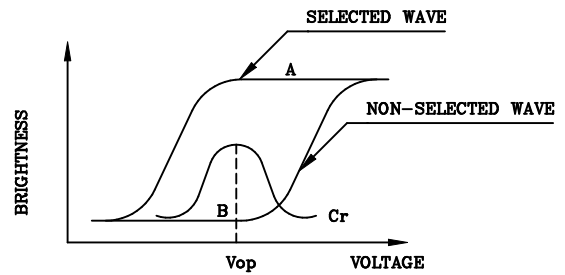

(negative type)

$$\text{Contrast Ratio : } Cr = A/B$$

*Conditions

Viewing Angle : 0
 Frame Frequency : 120Hz
 Applying Waveform : 1/N duty 1/a bias

5. BLOCK DIAGRAM

LCD

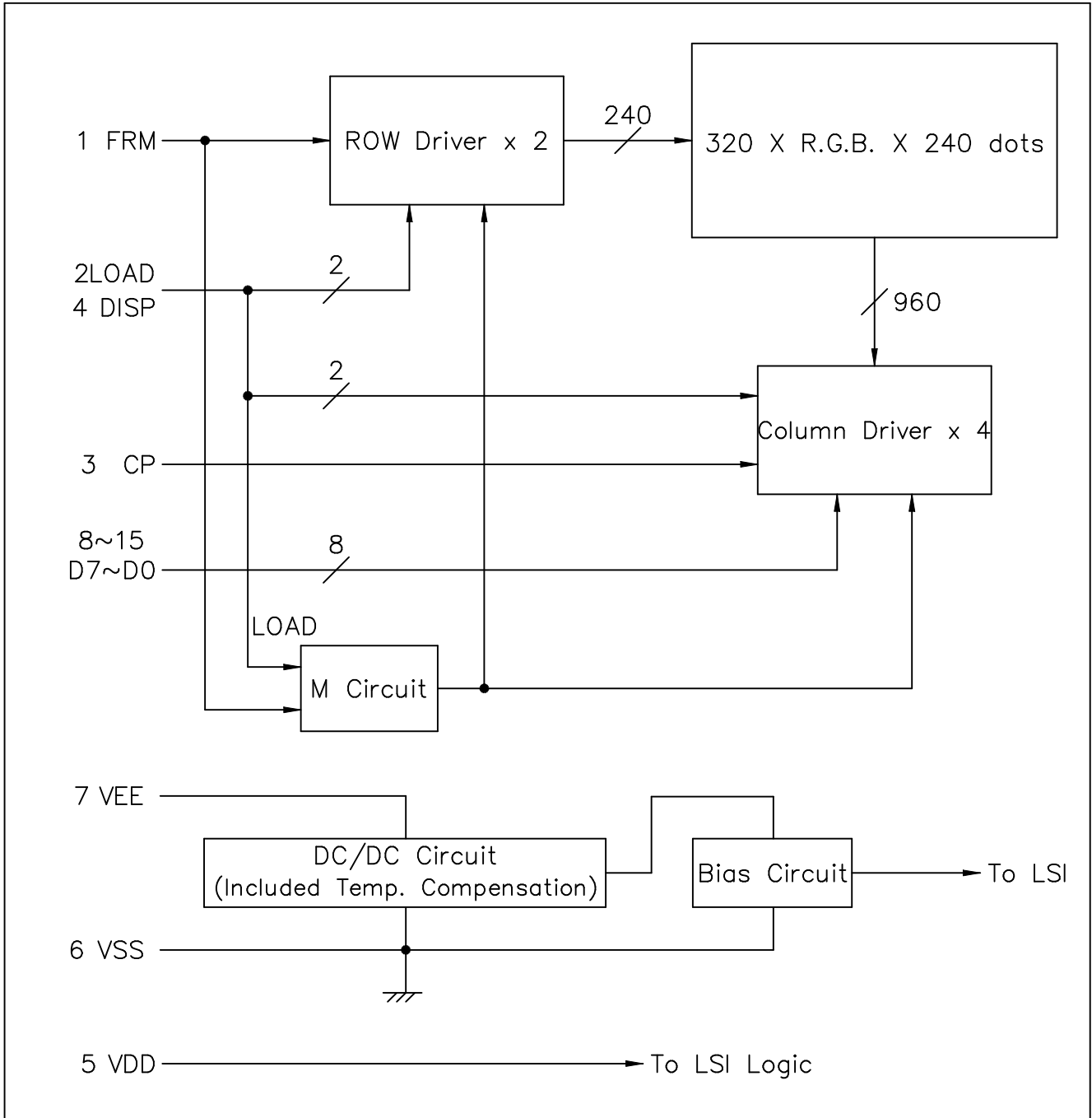

CCFL

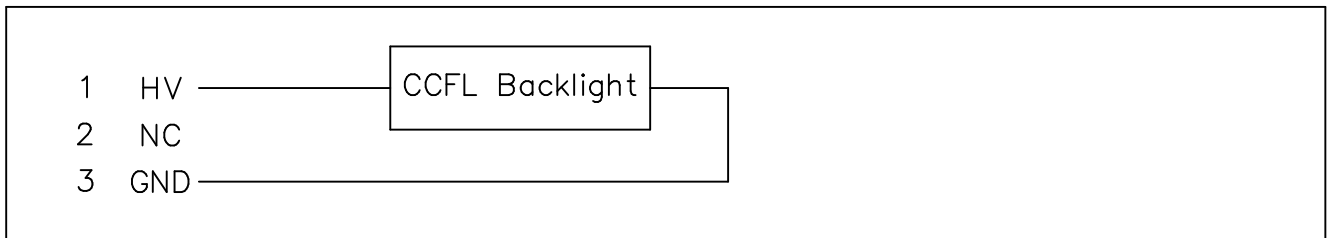

6. INTERNAL PIN CONNECTION

LCD

Pin No.	Symbol	Function	Level
1	FRM	Synchronous signal for driving scanning line	H
2	LOAD	Data signal latch clock	H → L
3	CP	Data signal shift clock	H → L
4	DISP	Display control signal	H(ON),L(OFF)
5	VDD	Power supply for logic	—
6	VSS	GND	—
7	VEE	Power supply for LCD	—
8	D7	Display data	H(ON),L(OFF)
9	D6		
10	D5		
11	D4		
12	D3		
13	D2		
14	D1		
15	D0		

CN1 : 53261-1571 (Molex)

Recommended Matching Connector : 51021-1500(Molex) or Compatible

CCFL

Pin No.	Symbol	Function	Level
1	HV	Power supply for CFL	AC
2	NC	Display data	—
3	GND	Ground line (from inverter)	—

CN2 : BHR-03VS-1 (JST)

Recommended Matching Connector : SM02-(8.0)B-BHS-1(JST) or Compatible

7. POWER SUPPLY

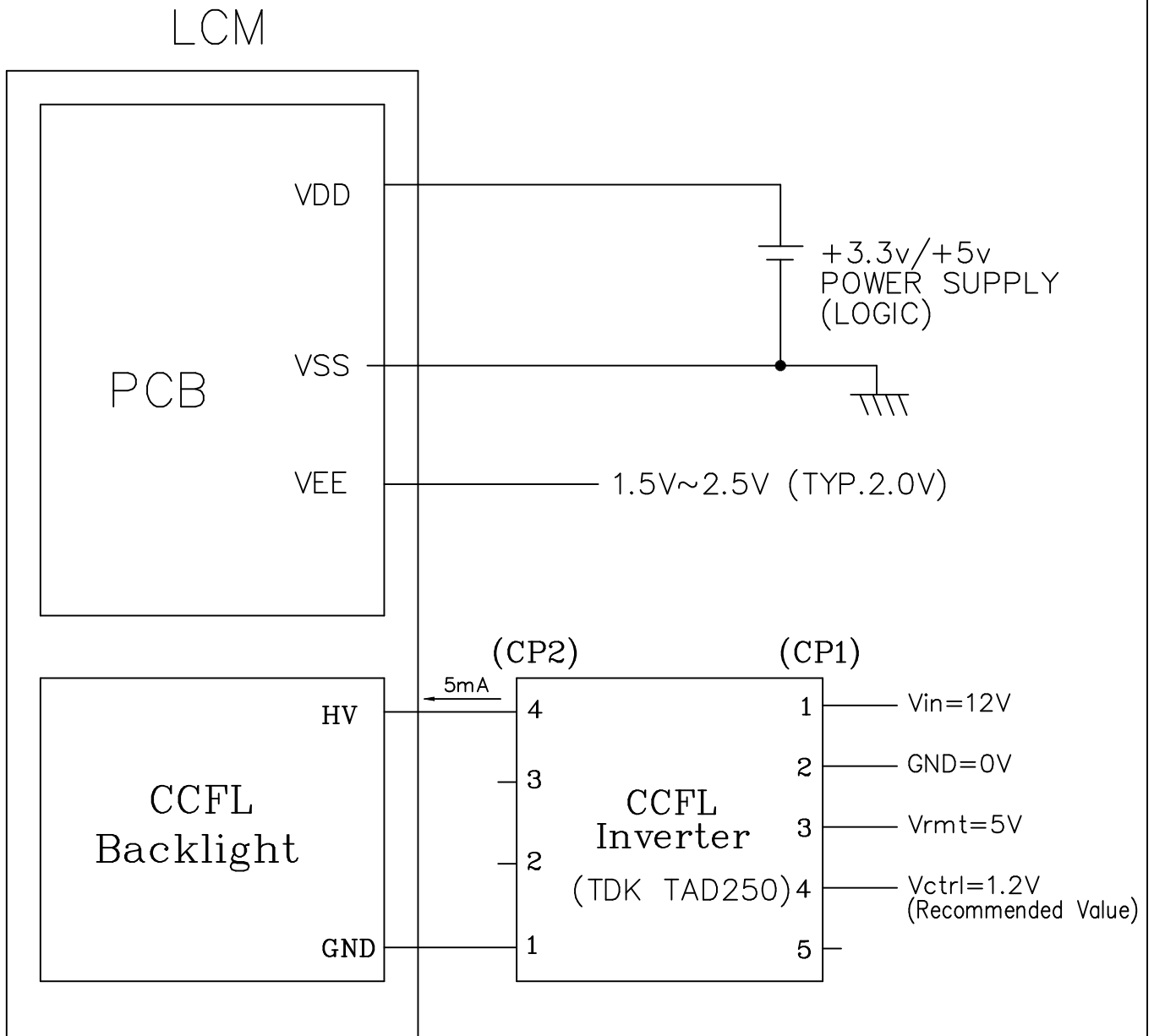

8. TIMING CHARACTERISTICS

8-1. INTERFACE TIMING

VDD=3.3/5.0V ± 10%

Parameter	SYMBOL	MIN.	MAX.	UNIT
CLOCK PULSE CYCLE TIME	t_{wck}	66/40	-	ns
CLOCK PULSE HIGH LEVEL WIDTH	t_{wckH}	23/12	-	ns
CLOCK PULSE LOW LEVEL WIDTH	t_{wckL}	23/14	-	ns
LATCH PULSE HIGH LEVEL WIDTH	t_{wLPH}	30/15	-	ns
CP→LOAD RISE TIME	t_{LD}	10/5	-	ns
CP→LOAD FALL TIME	t_{SL}	30/25	-	ns
LOAD→CP RISE TIME	t_{LS}	30/25	-	ns
LOAD→CP FALL TIME	t_{LH}	30/25	-	ns
CLOCK PULSE RISE/FALL TIME	t_r, t_f	-	50	ns
DATA SETUP TIME	t_{DS}	10/5	-	ns
DATA HOLD TIME	t_{DH}	25/15	-	ns
DISP LOW LEVEL WIDTH	t_{WDL}	1.2	-	μs
DISP CANCELLATION TIME	t_{SD}	100	-	ns
FRM SETUP TIME	t_{SU}	30	-	ns
FRM HOLD TIME	t_H	50	-	ns

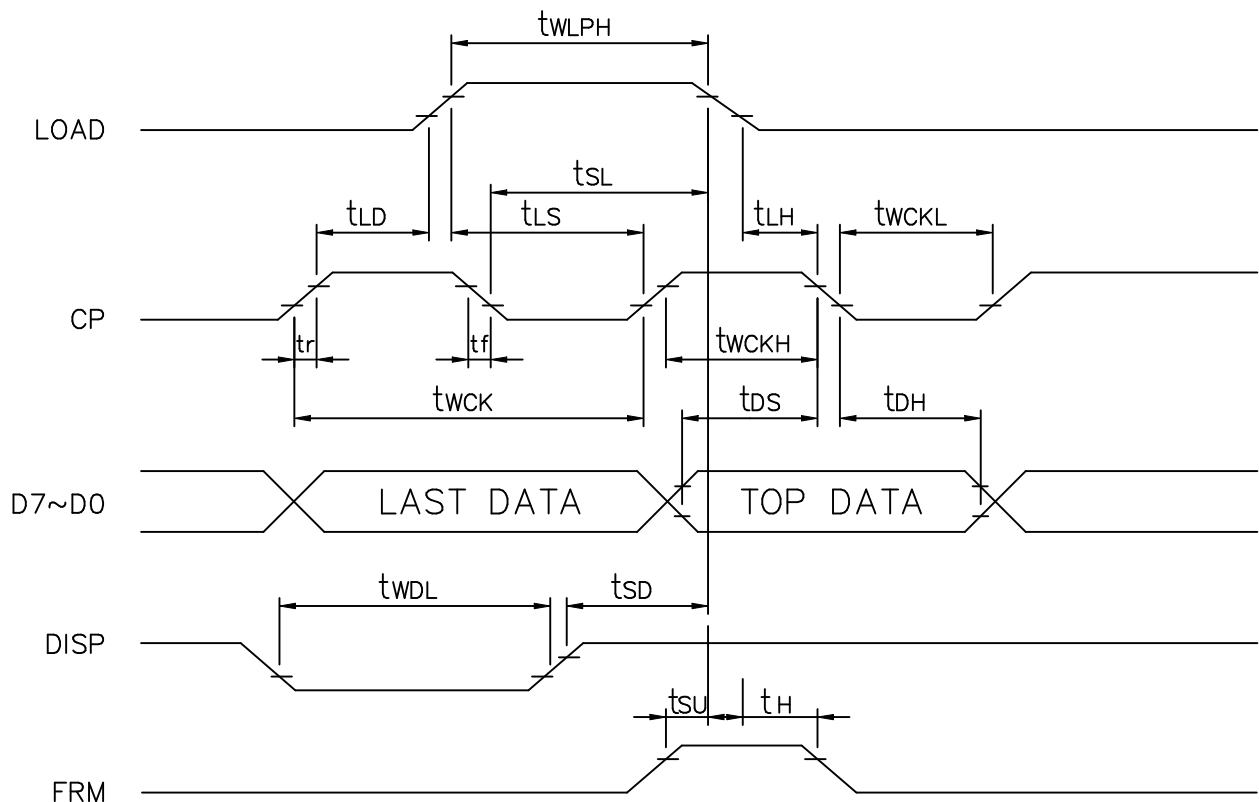

8-2. TIMING CHART

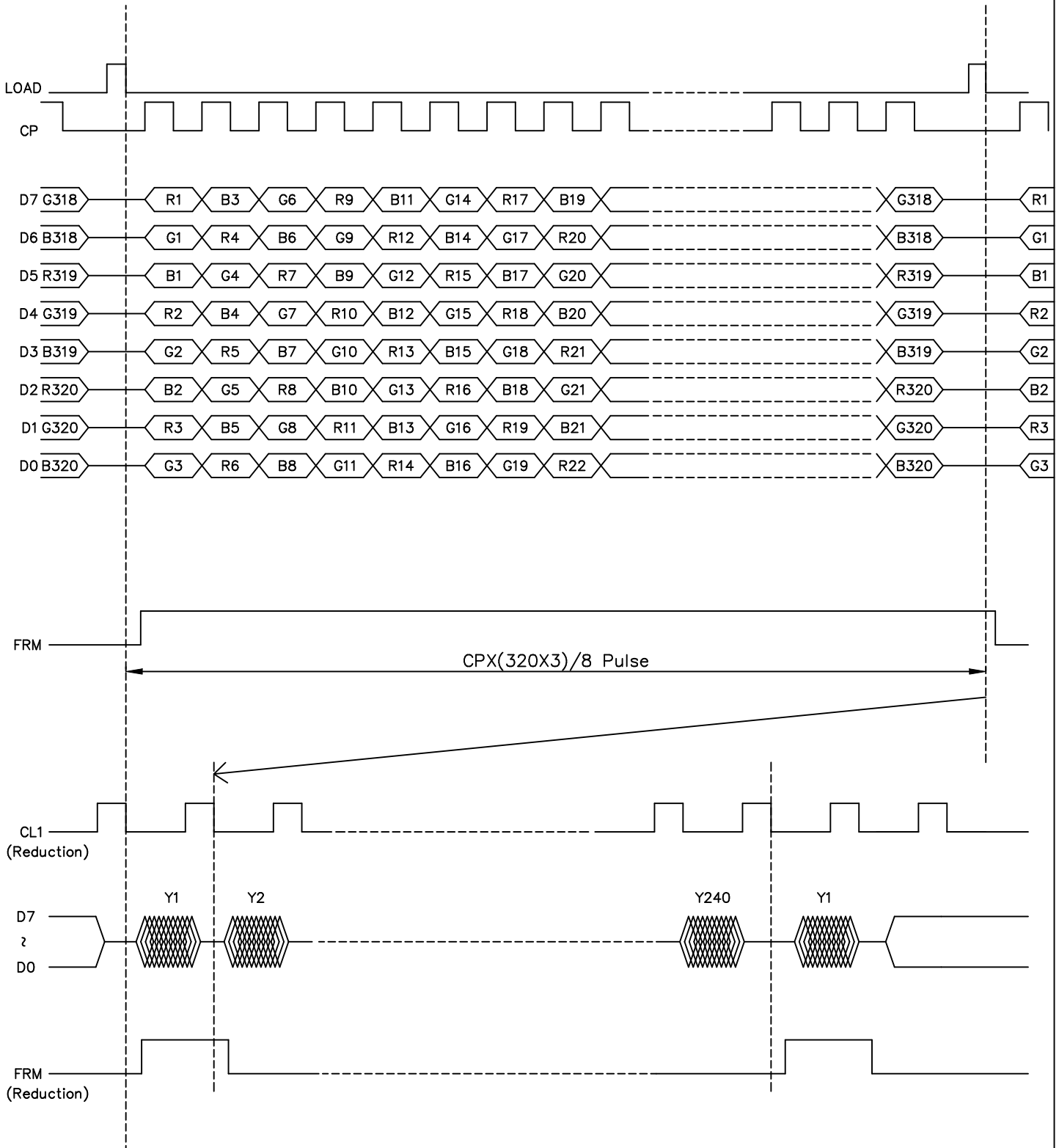

8-3. POWER ON/OFF TIMING

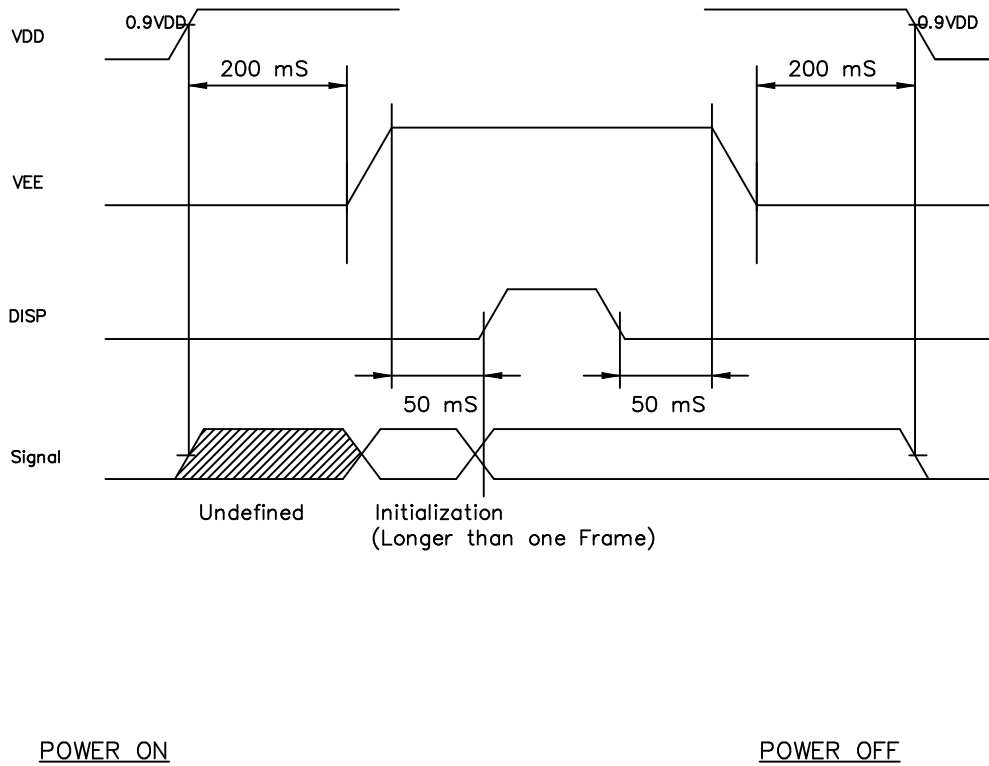

The missing pixels may occur when the LCM is driven beyond above power interface timing sequence.

8-4.DISPLAY PATTERN

START DATA

	Y1			Y2			Y3		
X1	R1	G1	B1	R2	G2	B2	R3	G3	B3
	D7	D6	D5	D4	D3	D2	D1	D0	D7
X2	R1	G1	B1	R2	G2	B2	R3	G3	B3
	D7	D6	D5	D4	D3	D2	D1	D0	D7

Y318			Y319			Y320		
R318	G318	B318	R319	G319	B319	R320	G320	B320
D0	D7	D6	D5	D4	D3	D2	D1	D0
R318	G318	B318	R319	G319	B319	R320	G320	B320
D0	D7	D6	D5	D4	D3	D2	D1	D0

X239	R1	G1	B1	R2	G2	B2	R3	G3	B3
	D7	D6	D5	D4	D3	D2	D1	D0	D7
X240	R1	G1	B1	R2	G2	B2	R3	G3	B3
	D7	D6	D5	D4	D3	D2	D1	D0	D7

R318	G318	B318	R319	G319	B319	R320	G320	B320
D0	D7	D6	D5	D4	D3	D2	D1	D0
R318	G318	B318	R319	G319	B319	R320	G320	B320
D0	D7	D6	D5	D4	D3	D2	D1	D0

9. RELIABILITY TEST

NORMAL TEMPERATURE RELIABILITY TEST

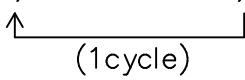
NO	ITEM	CONDITION			STANDARD	NOTE
1	High Temp. Storage	70°C	120Hrs		Appearance without defect	
2	Low Temp. Storage	-20°C	120Hrs		Appearance without defect	
3	High Temp. & High Humi. Storage	50°C 90%RH	120Hrs		Appearance without defect	
4	High Temp. Operating Display	50°C	120Hrs		Appearance without defect	
5	Low Temp. Operating Display	0°C	120Hrs		Appearance without defect	
6	Thermal Shock	-20°C,30min → 70°C,30min  (1cycle)			Appearance without defect	10 cycles

Inspection Provision

1. Purpose

The NAN YA inspection provision provides outgoing inspection provision and its expected quality level based on our outgoing inspection of NAN YA LCD produces.

2. Applicable Scope

The NAN YA inspection provision is applicable to the arrangement in regard to outgoing inspection and quality assurance after outgoing.

3. Technical Terms

3-1 NAN YA Technical Terms

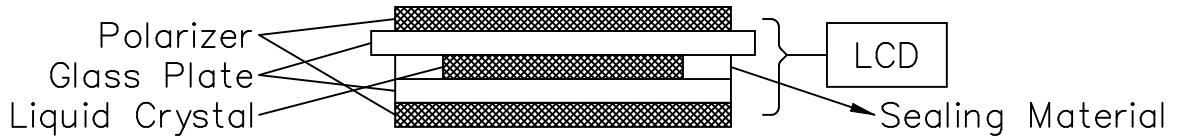

4. Outgoing Inspection

4-1 Inspection Method

MIL-STD-105E Level II Regular inspection

4-2 Inspection Standard

	Item		AQL(%)	Remarks
Major Defect	Dots	Opens Shorts Erroneous operation	0.4	faults which substantially lower the practicality and the initial purpose difficult to achieve.
	Solder appearance	Shorts Loose		
	Cracks	Display surface cracks		

	Dimensions	External from Dimensions	0.4	
Minor Defect	Inside the glass	Black spots	0.65	faults which appear to pose almost no obstacle to the practicality, effective use, and operation.
	Polarizing plate	Scratches, foreign Matter, air bubbles, and peeling		
	Dots	Pinhole, deformation		
	Color tone	Color unevenness		
	Solder appearance	Cold solder Solder projections		

4-3 Inspection Provisions
*Viewing Area Definition

Fig. 1

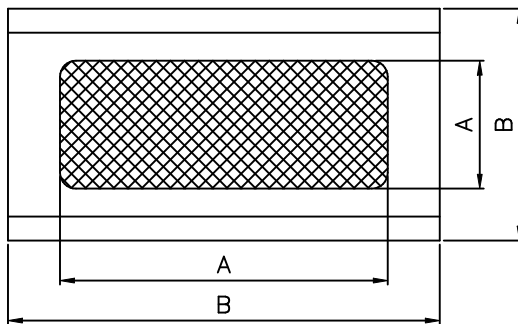

A : Zone Viewing Area
B : Zone Glass Plate Outline

*Inspection place to be 500 to 1000 lux illuminance uniformly without glaring.
The distance between luminous source(daylight fluorescent lamp and cool white fluorescent lamp) and sample to be 30cm to 50cm.

*Test and measurement are performed under the following conditions, unless otherwise specified.

Temperature 20± 15°C
Humidity 65± 20%R.H.
Pressure 860~1060hPa(mmbar)

In case of doubtful judgment, it is performed under the following conditions.

Temperature 20± 2°C
Humidity 65± 5%R.H.
Pressure 860~1060hPa(mmbar)

5.Specification for quality check
5-1 Electrical characteristics

NO.	Item	Criterion
1	Non operational	Fail
2	Miss operating	Fail
3	Missing dot	Fail
4	Contrast irregular	Fail
5	Response time	Within Specified value
6	Backlight turn on/off	Within Specified value

5-2 External Appearance Defect

NO.	Item	Criterion																							
1	Black spots, foreign matter, and white spots (Including light leakage due to pinholes of polarizing plates, etc.)	<p>(1)-1-Spots</p> <table border="1" data-bbox="711 477 1422 813"> <thead> <tr> <th>Average Diameter(mm):D</th> <th>Number of pieces permitted</th> <th>Minimum Space</th> </tr> </thead> <tbody> <tr> <td>$D \leq 0.2$</td> <td>Ignore</td> <td>-</td> </tr> <tr> <td>$0.2 < D \leq 0.3$</td> <td>5</td> <td>10mm</td> </tr> <tr> <td>$0.3 < D \leq 0.4$</td> <td>2</td> <td>30mm</td> </tr> <tr> <td>$0.4 < D$</td> <td>0</td> <td></td> </tr> </tbody> </table> <p>Number of total pieces is set to within 5 pieces.</p> <p>Note that when there are 2 pieces or more, they are not to be concentrated. Set as: Average diameter = (Long diameter + Short diameter)/2</p> <p>(1)-2-Blurred Spots(At lighting condition)</p> <table border="1" data-bbox="711 1234 1358 1473"> <thead> <tr> <th>Average Diameter(mm):D</th> <th>Number of pieces permitted</th> </tr> </thead> <tbody> <tr> <td>$D \leq 0.3$</td> <td>Ignore</td> </tr> <tr> <td>$0.3 < D \leq 0.75$</td> <td>5</td> </tr> <tr> <td>$0.75 < D$</td> <td>0</td> </tr> </tbody> </table> <p>Number of total pieces is set to within 5 pieces.</p> <p>Note that when there are 2 pieces or more, they are not to be concentrated. Set as: Average diameter = (Long diameter + Short diameter)/2</p>	Average Diameter(mm):D	Number of pieces permitted	Minimum Space	$D \leq 0.2$	Ignore	-	$0.2 < D \leq 0.3$	5	10mm	$0.3 < D \leq 0.4$	2	30mm	$0.4 < D$	0		Average Diameter(mm):D	Number of pieces permitted	$D \leq 0.3$	Ignore	$0.3 < D \leq 0.75$	5	$0.75 < D$	0
Average Diameter(mm):D	Number of pieces permitted	Minimum Space																							
$D \leq 0.2$	Ignore	-																							
$0.2 < D \leq 0.3$	5	10mm																							
$0.3 < D \leq 0.4$	2	30mm																							
$0.4 < D$	0																								
Average Diameter(mm):D	Number of pieces permitted																								
$D \leq 0.3$	Ignore																								
$0.3 < D \leq 0.75$	5																								
$0.75 < D$	0																								

1	Line	<p>(1)-1-Lines</p> <table border="1" data-bbox="711 427 1453 712"> <thead> <tr> <th>Width(mm): W</th> <th>Length(mm): L</th> <th>Number of pieces permitted</th> </tr> </thead> <tbody> <tr> <td>$W \leq 0.03$</td> <td>Ignore</td> <td>Ignore</td> </tr> <tr> <td>$0.03 < W \leq 0.08$</td> <td>$L \leq 4$</td> <td>2</td> </tr> <tr> <td>$0.08 < W \leq 0.1$</td> <td>$L \leq 1$</td> <td>1</td> </tr> </tbody> </table> <p>Object exceeding 0.1mm follow the standards of the spots form. Note that when there are 2 pieces or more, they are not to be concentrated.</p> <p>(1)-2-Blurred Lines(At lighting condition)</p> <table border="1" data-bbox="711 1016 1453 1301"> <thead> <tr> <th>Width(mm): W</th> <th>Length(mm): L</th> <th>Number of pieces permitted</th> </tr> </thead> <tbody> <tr> <td>$W \leq 0.03$</td> <td>Ignore</td> <td>Ignore</td> </tr> <tr> <td>$0.03 < W \leq 0.08$</td> <td>$L \leq 3$</td> <td>6</td> </tr> <tr> <td>$0.08 < W$</td> <td>$3 < L$</td> <td>None</td> </tr> </tbody> </table> <p>Object exceeding 0.1mm follow the standards of the spots form. Note that when there are 2 pieces or more, they are not to be concentrated.</p>	Width(mm): W	Length(mm): L	Number of pieces permitted	$W \leq 0.03$	Ignore	Ignore	$0.03 < W \leq 0.08$	$L \leq 4$	2	$0.08 < W \leq 0.1$	$L \leq 1$	1	Width(mm): W	Length(mm): L	Number of pieces permitted	$W \leq 0.03$	Ignore	Ignore	$0.03 < W \leq 0.08$	$L \leq 3$	6	$0.08 < W$	$3 < L$	None
Width(mm): W	Length(mm): L	Number of pieces permitted																								
$W \leq 0.03$	Ignore	Ignore																								
$0.03 < W \leq 0.08$	$L \leq 4$	2																								
$0.08 < W \leq 0.1$	$L \leq 1$	1																								
Width(mm): W	Length(mm): L	Number of pieces permitted																								
$W \leq 0.03$	Ignore	Ignore																								
$0.03 < W \leq 0.08$	$L \leq 3$	6																								
$0.08 < W$	$3 < L$	None																								
2	Scratches(Glass, reflection plates, and polarizing plates)	In accordance with black spots. (At non lighting condition)																								
3	Color irregular	Not remarkable color irregular.																								

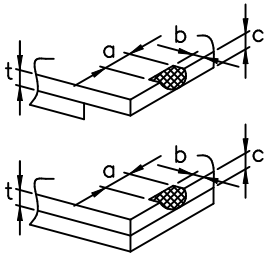
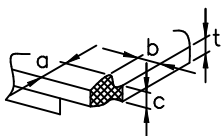
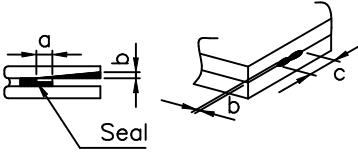
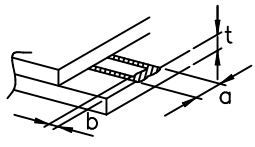
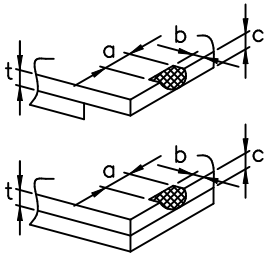
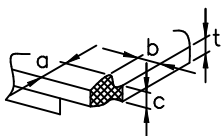
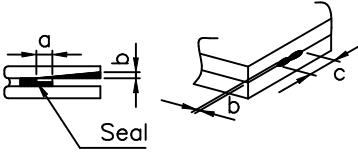
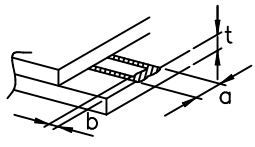
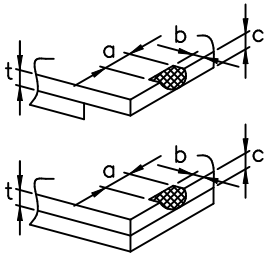
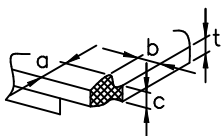
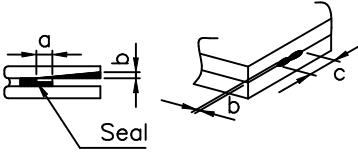
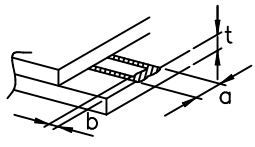
<p>4 Air bubbles polarizing plates, and reflection plates</p>	<table border="1" data-bbox="710 376 1225 667"> <tr> <th data-bbox="710 376 970 521">Average Diameter (mm):D</th> <th data-bbox="970 376 1225 521">Number of pieces permitted</th> <th data-bbox="1225 376 1476 667" rowspan="2">Average diameter = (Long diameter + Short diameter)/2</th> </tr> <tr> <td data-bbox="710 521 970 667">D ≤ 0.3 0.3 < D</td> <td data-bbox="970 521 1225 667">Ignore 0</td> </tr> </table> <p data-bbox="710 683 1476 779">Note that when there are 4 pieces or more, they are not to be concentrated.</p>		Average Diameter (mm):D	Number of pieces permitted	Average diameter = (Long diameter + Short diameter)/2	D ≤ 0.3 0.3 < D	Ignore 0					
Average Diameter (mm):D	Number of pieces permitted	Average diameter = (Long diameter + Short diameter)/2										
D ≤ 0.3 0.3 < D	Ignore 0											
<p>5 Cracks</p>	<table border="1" data-bbox="662 779 1476 1964"> <tr> <td data-bbox="662 779 1066 1169"> <p>(1)General crack</p>  </td> <td data-bbox="1066 779 1476 1169"> <p>a ≤ 5 b ≤ 2 c ≤ t</p> <p>Where, a and b are ignored when less than or equal to 0.5 The numbers of pieces are set at up to 5 pieces.</p> </td> </tr> <tr> <td data-bbox="662 1169 1066 1361"> <p>(2)Corner crack</p>  </td> <td data-bbox="1066 1169 1476 1361"> <p>a ≤ 2.5 b ≤ 2.5 c ≤ t a + b ≤ 4</p> </td> </tr> <tr> <td data-bbox="662 1361 1066 1635"> <p>(3)Seal portion crack</p>  </td> <td data-bbox="1066 1361 1476 1635"> <p>a ≤ The seal width × 1/3 b ≤ t × 2/3 c ≤ 5</p> <p>The numbers of pieces are set at up to 5 pieces.</p> </td> </tr> <tr> <td data-bbox="662 1635 1066 1870"> <p>(4)ITO Pin crack</p>  </td> <td data-bbox="1066 1635 1476 1870"> <p>a ≤ 5 b ≤ 1/3 pin length c ≤ t</p> </td> </tr> <tr> <td data-bbox="662 1870 1066 1964"> <p>(5)Progressive cracks</p> </td> <td data-bbox="1066 1870 1476 1964"> <p>All taken to be unacceptable.</p> </td> </tr> </table>		<p>(1)General crack</p> 	<p>a ≤ 5 b ≤ 2 c ≤ t</p> <p>Where, a and b are ignored when less than or equal to 0.5 The numbers of pieces are set at up to 5 pieces.</p>	<p>(2)Corner crack</p> 	<p>a ≤ 2.5 b ≤ 2.5 c ≤ t a + b ≤ 4</p>	<p>(3)Seal portion crack</p> 	<p>a ≤ The seal width × 1/3 b ≤ t × 2/3 c ≤ 5</p> <p>The numbers of pieces are set at up to 5 pieces.</p>	<p>(4)ITO Pin crack</p> 	<p>a ≤ 5 b ≤ 1/3 pin length c ≤ t</p>	<p>(5)Progressive cracks</p>	<p>All taken to be unacceptable.</p>
<p>(1)General crack</p> 	<p>a ≤ 5 b ≤ 2 c ≤ t</p> <p>Where, a and b are ignored when less than or equal to 0.5 The numbers of pieces are set at up to 5 pieces.</p>											
<p>(2)Corner crack</p> 	<p>a ≤ 2.5 b ≤ 2.5 c ≤ t a + b ≤ 4</p>											
<p>(3)Seal portion crack</p> 	<p>a ≤ The seal width × 1/3 b ≤ t × 2/3 c ≤ 5</p> <p>The numbers of pieces are set at up to 5 pieces.</p>											
<p>(4)ITO Pin crack</p> 	<p>a ≤ 5 b ≤ 1/3 pin length c ≤ t</p>											
<p>(5)Progressive cracks</p>	<p>All taken to be unacceptable.</p>											

6	Outer dimensions	Should be within the tolerance.
7	Newton ring(touch panel)	Orbicular of interference fringes is not allowed in the optimum contrast within the active area under viewing angle.
8	Soldering	Should be no defective soldering such as shorting, loose terminal cold solder, peeling of printed circuit board pattern, improper mounting position, etc.

5-3 Dot Appearance Defect

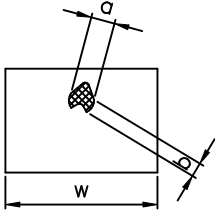
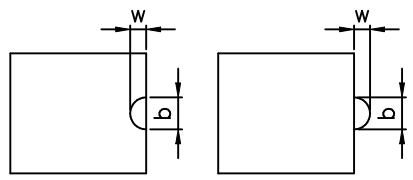
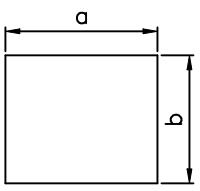
NO.	Item	Criteria
1	Pinhole	 <p>Dot display a and b are each $\leq 0.2\text{mm}$ The overall total is taken be with in 10 units. Note that they are not to be concentrated.</p>
2	Missing	 <p>Dot display a and b are each $\leq 0.2\text{mm}$ The overall total is taken to be with in 10 units.</p>
3	Thick and thin display	 <p>Taken to be within $\pm 1.5\%$ of display character width(a) and height(b).</p>

NOTICE:

• SAFETY

- 1.If the LCD panel breaks, be careful not to get the liquid crystal to touch your skin.
- 2.If the liquid crystal touches your skin or clothes, please wash it off immediately by using soap and water.

• HANDLING

- 1.Avoid static electricity which can damage the CMOS LSI.
- 2.Do not remove the panel or frame from the module.
- 3.The polarizing plate of the display is very fragile. So, please handle it very carefully.
- 4.Do not wipe the polarizing plate with a dry cloth, as it may easily scratch the surface of plate.
- 5.Do not use ketonics solvent & Aromatic solvent. Use a soft cloth soaked with a cleaning naphtha solvent.

• STORAGE

- 1.Store the panel or module in a dark place where the temperature is $25^{\circ}\text{C}\pm 5^{\circ}\text{C}$ and the humidity is below 65% RH.
- 2.Do not place the module near organics solvents or corrosive gases.
- 3.Do not crush, shake, or jolt the module.

• TERMS OF WARRANT

- 1.Acceptance inspection period
The period is within one month after the arrival of contracted commodity at the buyer's factory site.
- 2.Applicable warrant period
The period is within twelve months since the date of shipping out under normal using and storage conditions.

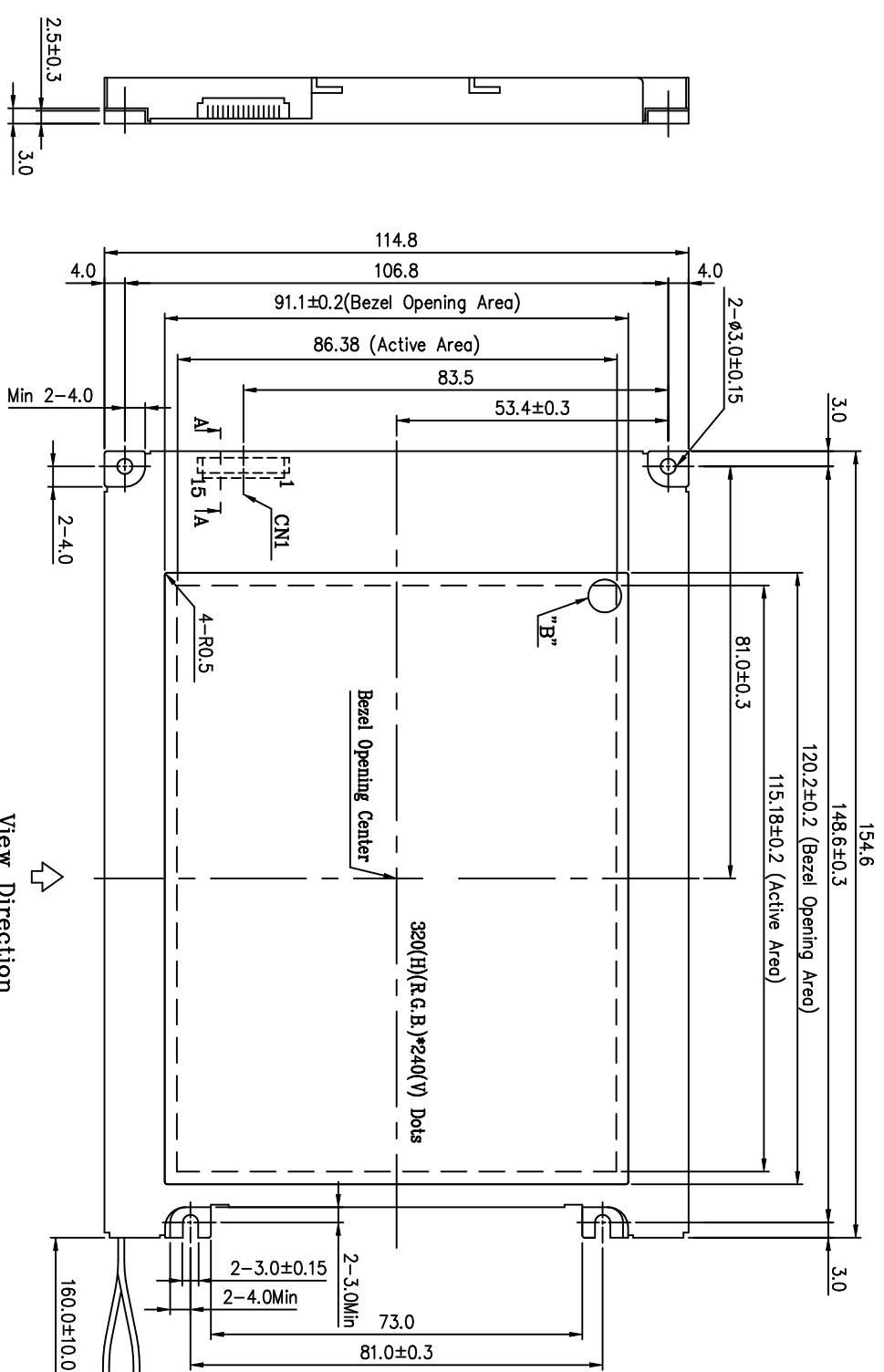
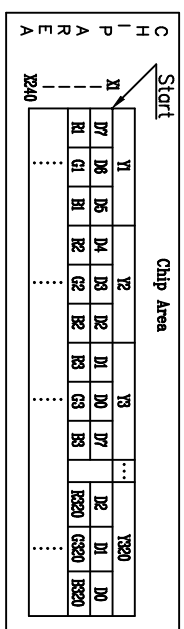

View Direction

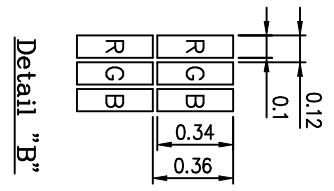

CN1 : 53261-1571 (Molex)

Pin No.	Symbol	Function	Level
1	FRM	Synchronous signal for driving scanning line	H
2	LOAD	Data signal latch clock	H → L
3	CP	Data signal shift clock	H → L
4	DISP	Display control signal	H(ON),L(OFF)
5	VDD	Power supply for logic	-
6	VSS	GND	-
7	VEE	Power supply for LCD	-
8	D7	Power supply for CCFL NO Connection	Pin No.
9	D6		Symbol
			Function
		Level	

Pin No.	Symbol	Function	Level
10	D6	Display data H(ON),L(OFF)	
11	D4		
12	D3		
13	D2		
14	D1		
15	DO		

Pin No.	Symbol	Function	Level
1	HV	Power supply for CCFL	AC
2	NC	NO Connection	-
3	GND	Ground line (from inverter)	-

GENERAL TOLERANCE LIST

DIMENSION	TOLERANCE
L ≤ 6	±0.25 (mm)
6 < L ≤ 18	±0.3 (mm)
18 < L ≤ 50	±0.4 (mm)
50 < L ≤ 125	±0.5 (mm)
125 < L	±0.6 (mm)
ANGLE	±1° (DEG)

- Notes :
- Resolution : 320(H)(R.G.B) x 240(V) Dots
 - Backlight : CCFL
 - Frame Material : SECC (t=0.5)

南亞塑膠工業股份有限公司
NAN YA PLASTICS CORPORATION

製品圖

LCBFBTB61M70S

REV. NO.	DESCRIPTION	DATE	DESIGN	CHECK	APPROVE	DWG NO.
1						M B 6 1 A D 7 0 A

NAME	DATE	THIRD ANGLE P.

APPROVE	CHECK	DESIGN	DRAWN
		Compos Chen 95.07.25	Compos Chen 95.07.25

SCALE	UNIT
1/1	mm

THE NOTES OF LCM USING

LCM is easy to damage.

Please follow the notes as bellows, and be careful of handling!

Correct handling

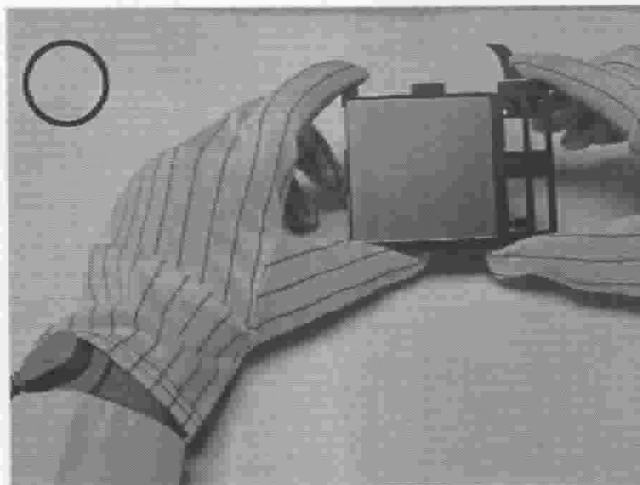
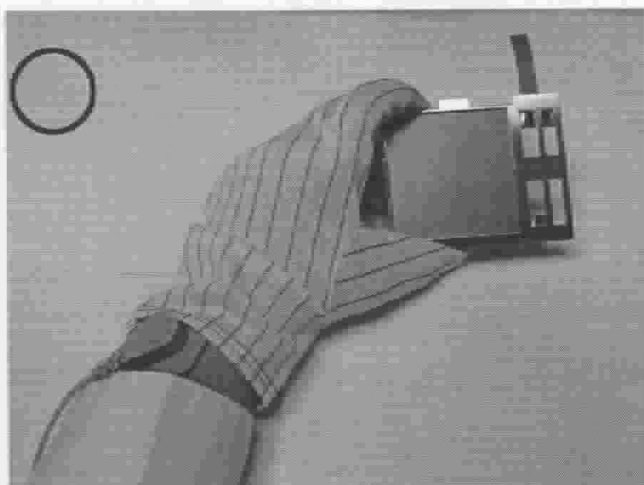

As above picture, please handle with glove by LCM edges and full EOS/ESD protection.

Incorrect handling

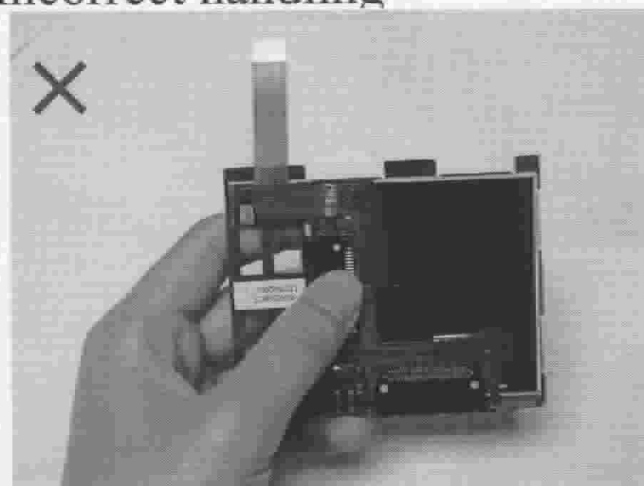

Please don't touch IC directly.

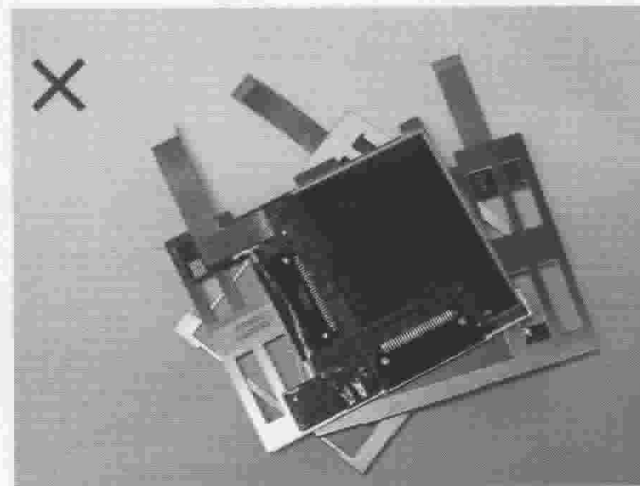

Please don't put one on another LCM.

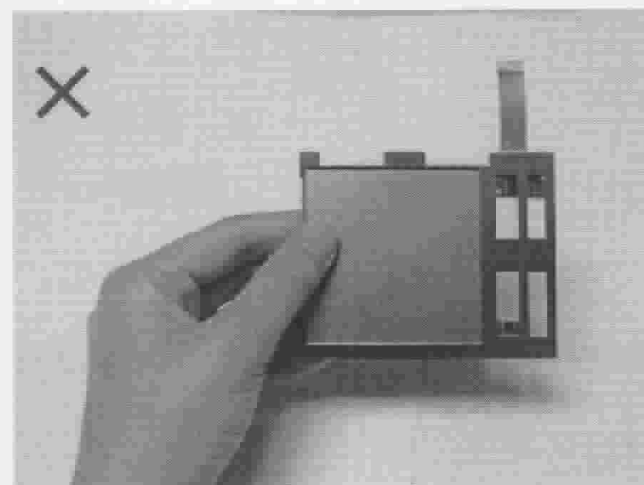

Please don't hold the surface of LCM.

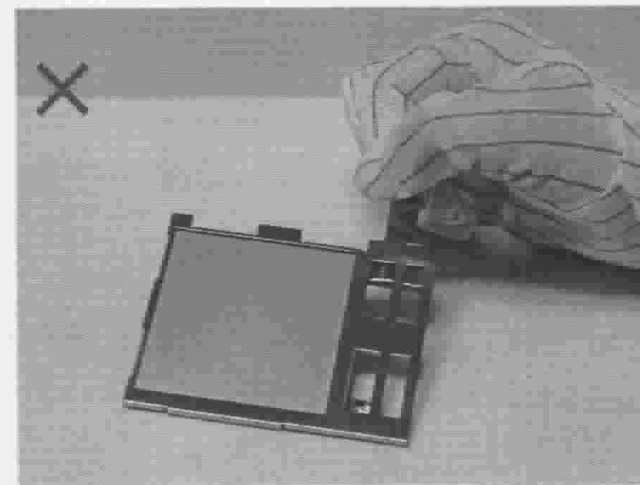

Please don't stretch interface of output.

THE NOTES OF LCD USING

LCD is easy damage.

Please follow notes as bellows, and be careful of handling!

Correct handling

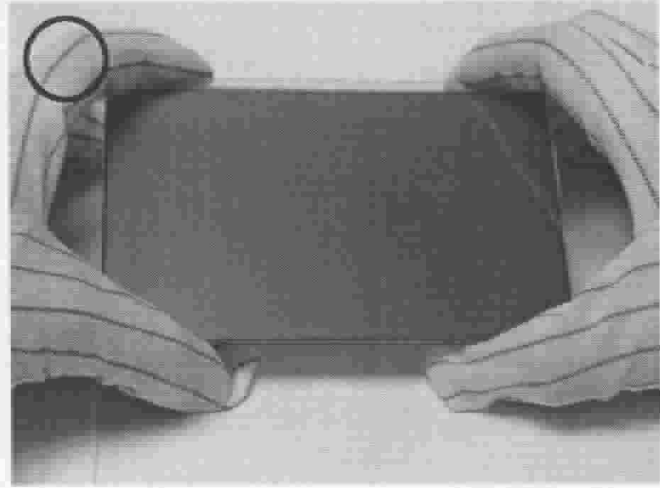
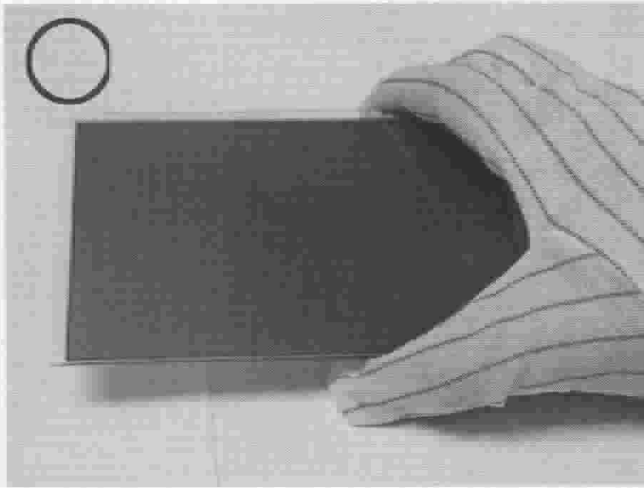

As above picture, please handle with glove by LCD edges and full EOS/ESD protection.

Incorrect handling

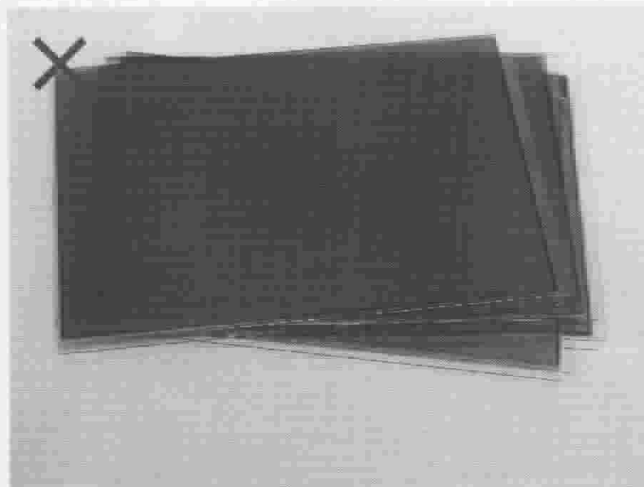

Please don't put one on another LCD.

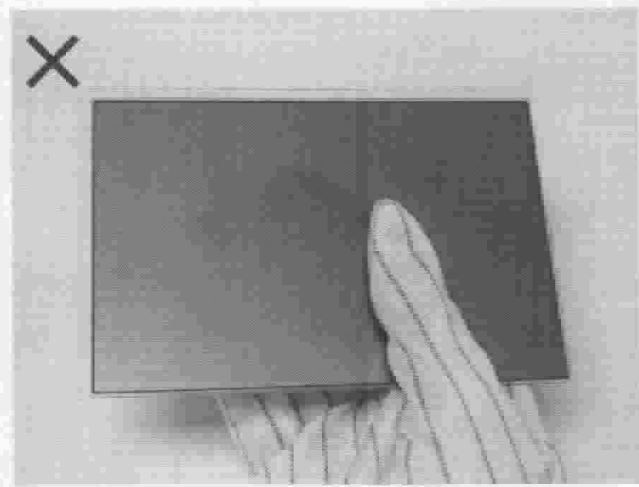

Please don't hold the surface of LCD.

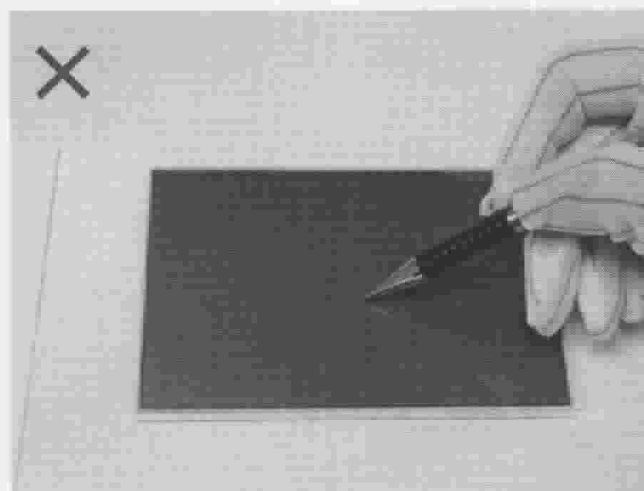

Please don't operate with sharp stick such as sharp pencil.

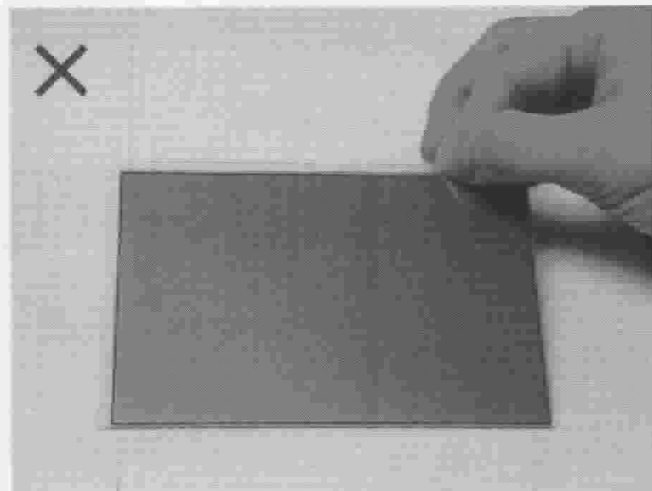

Please don't touch ITO glass without anti-static gloves.

