

NAN YA PLASTICS CORPORATION

SPECIFICATION OF LCD MODULE PRODUCT NO.: LCBHBTB61M2S

SPEC. NO: LMB61-2A-0

CUSTOMER
APPROVED BY
DATE:

LCD DEPARTMENT
ELECTRONIC MATERIALS DIVISION
NAN YA PLASTICS CORPORATION
201, TUNG HWA N. ROAD, TAIPEI
TEL: 886-2-27122211 EXT. 5993~5995
FAX: 886-2-27178253
E-mail: lcdsales@npc.com.tw

EDITED ON : Aug. 25. 2006

Q.C. DEPT.	DESIGN MANAGER	DESIGN CHECK	DESIGNER
			W. R. HSU

1. MECHANICAL DATA

NO	ITEM	CONTENTS	UNIT
1	Product No.	LCBHBTB61M2S	-
2	Module Size	168.0 (W) x 111.0 (H) x 9.4 (D)	mm
3	Dot Size	0.10 (W) x 0.34 (H)	mm
4	Dot Pitch	0.12 (W) x 0.36 (H)	mm
5	Number of Dots	320 x RGB (W) x 240 (H)	Dot
6	Duty	1/240	-
7	LCD Display Mode	FSTN, Color STN Module	-
8	Rear Polarizer	Color Transmissive Type	-
9	Viewing Direction	6	O'clock
10	Backlight	CCFL	-
11	Controller	Excluded	-
12	DC/DC Converter	Excluded	-
13	Touch Panel	Included	-
14	Weight	230 (Approx.)	g

Note :

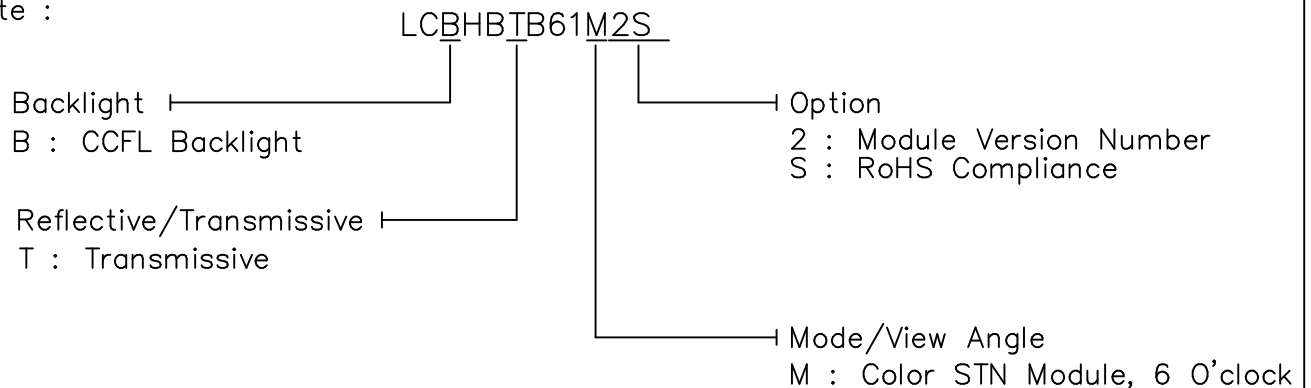

RoHS Compliance.

Nan Ya guarantees that this project doesn't include any materials (6 materials) or includes less than specified quantities which are regulated by RoHS Compliance.

REV/DATE	R0/ 08.25.06'					BY W.R.HSU
----------	------------------	--	--	--	--	---------------

2. ABSOLUTE MAXIMUM RATINGS

(1) ELECTRICAL ABSOLUTE RATINGS

VSS=0V

	SYMBOL	MIN.	MAX.	UNIT	COMMENT
Power Supply for Logic	VDD-VSS	-0.3	5.5	V	
Input Voltage	VI	-0.3	VDD	V	
Static Electricity	-	-	-	-	Note 1

Note 1 LCM should be grounded during handling LCM.

(2) ENVIRONMENTAL ABSOLUTE MAXIMUM RATINGS

ITEM	NORMAL TEMP.			
	OPERATING		STORAGE	
	MIN.	MAX.	MIN.	MAX.
Ambient Temperature	0	50	-20	70
Humidity (Without Condensation)	Note 2,4		Note 3,4	

Note 2 $T_a \leq 50^\circ\text{C}$: 80%RH max

Note 3 Please refer to item of reliability test

Note 4 Background color will change slightly depending on ambient temperature.
That phenomenon is reversible.

3. ELECTRICAL CHARACTERISTICS

3-1. ELECTRICAL CHARACTERISTICS OF LCM

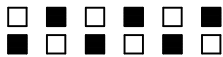
ITEM	SYMBOL	CONDITION		MIN.	TYP.	MAX.	UNIT
Power Supply for Logic	VDD-VSS	-		4.5	5.0	5.5	V
Input Voltage	VIH	H level		0.8VDD	-	VDD	V
	VIL	L level		0	-	0.2VDD	
Recommended LC Driving Voltage	VLCD-VSS (Vop)	Duty= 1/240	0°C	23.2	23.6	24.0	V
			25°C	22.2	22.6	23.0	
			50°C	21.0	21.4	21.8	
Power Supply Current	IDD	VDD-VSS=5.0V VEE-VSS=22.6V Ta=25°C Pattern:		-	1.5	5	mA
	ILCD			-	6.5	13	
Surface Luminance of LCM	L	IL=5 mArms Pattern: Dots All ON(White)		50	70	-	cd/m ²
		IL=5 mArms Pattern: Dots All OFF(Black)		-	5	-	
Recommended Frame Frequency for Optimum Contrast	FLM	-		115	120	125	Hz

3-2.ELECTRICAL CHARACTERISTICS OF BACKLIGHT

Used Lamp Rating

Temp.=25°C

ITEM	SYMBOL	MIN.	TYP.	MAX.	UNIT	REMARK
Lamp Voltage	V_L	-	296	-	Vrms	-
Lamp current	I_L	-	5	-	mArms	-
Lamp power consumption	P_L	-	1.48	-	W	(*1)
Starting voltage	V_s	-	-	460	Vrms	$T_a=25^\circ\text{C}$
		-	-	580	Vrms	$T_a=0^\circ\text{C}$
Lamp life time	L_L	-	20000	-	hrs	at $I_L = 5 \text{ mArms}$ $T_a=25^\circ\text{C}$ (*2)

(*1) Power consumption excluded inverter loss .

(*2) Lamp life time is defined as follows : The final brightness is at 50% of original brightness

3-3.ELECTRICAL CHARACTERISTICS OF RECOMMENDED INVERTER TDK CXA-L10L

3-3-1 GENERAL SPECIFICATIONS

OPERATION TEMPERATURE : -10°C~60°C

STORAGE TEMPERATURE : -20°C~85°C

DIMENSION : 44.0(L)mm x 21.0(W)mm x MAX 18.0(H)mm

3-3-2 PIN ASSIGNMENTS

INPUT (CN1) CONNECTOR :

OUTPUT (CN2) CONNECTOR :

NO.	FUNCTION
1	VIN
2	GND

NO.	FUNCTION
3	OUT1
4	OUT2
5	OUT GND

3-3-3 RELATIONSHIP BETWEEN VIN & TUBE CURRENT

ITEM	SYMBOL	MIN.	TYP.	MAX.	UNIT	REMARK
Input Voltage	VIN	-	10.1	-	V	
Tube Current	IL	-	5	-	mA	

3-4.CHARACTERISTICS OF TOUCH PANEL

Used Touch Panel Rating

Temp.=25°C

ITEM	SYMBOL	CONDITION	MIN.	TYP.	MAX.	UNIT
Applied Rating Voltage	V_R	—	—	—	7.0	V
Operating Temperature	T_{OPR}	20%~85% R.H. Max. Avoid Dew Condensation at Any Time	-5	—	60	°C
Storage Temperature	T_{STO}		-30	—	70	
Resistance of Terminal Electrodes	R_{ETD}	X Electrode	300	—	900	Ω
		Y Electrode	200	—	600	
Linearity	L	—	—	—	1.5	%
Insulation Resistance	R_{OFF}	$V_{DC}=25V$	10	—	—	M Ω
Transparency	T	According to JIS-K7015	—	80	—	%
Surface Hardness	S_H	According to JIS-K5400	3	—	—	H

Test condition : Touch panel is placed horizontally in a vessel and no power is supplied to T/P.
Normal state is temperature : $25\pm 10^\circ\text{C}$, relative humidity : $60\pm 25\%$

4. OPTICAL CHARACTERISTICS

4-1. Optical Char. of Normal Temp. Mode

AT V_{OP}

ITEM MODE		Cr(Contrast Ratio)						θ (Viewing Angle)		ϕ (Viewing Angle)	
		0°C		25°C		50°C		25°C		25°C	
		MIN.	TYP.	MIN.	TYP.	MIN.	TYP.	MIN.	TYP.	MIN.	TYP.
T	M	14	20	17	25	3.5	5	—	F: 60 R: 30	—	L: 55 R: 55
NOTE		NOTE 6						NOTE 5			

NOTE :

T : Transmissive

M : Color STN Module, 6 O'clock

AT $\phi=0^\circ$ $\theta=0^\circ$

ITEM	SYMBOL	CONDITION	MIN.	TYP.	MAX.	UNIT	NOTE
Response Time (rise)	Tr	0°C	640	800	1200	ms	NOTE 2
		25°C	240	300	450		
		50°C	80	100	150		
Response Time (fall)	Tf	0°C	360	450	670	ms	NOTE 2
		25°C	80	100	150		
		50°C	48	60	90		

4-2. Color of CIE Coordinate

Ta = 25°C

ITEM		SYMBOL	CONDITION	VALUE	NOTE
Color of CIE Coordinate	Red	X	$\phi=0^\circ, \theta=0^\circ$	0.54	Note*
		y		0.33	
	Green	X	$\phi=0^\circ, \theta=0^\circ$	0.30	
		y		0.54	
	Blue	X	$\phi=0^\circ, \theta=0^\circ$	0.16	
		y		0.13	
	White	X	$\phi=0^\circ, \theta=0^\circ$	0.30	
		y		0.31	

Note* Measuring at position 3 on Fig.1
CIE chromaticity diagram

Tolerance : ± 0.05

Fig.1

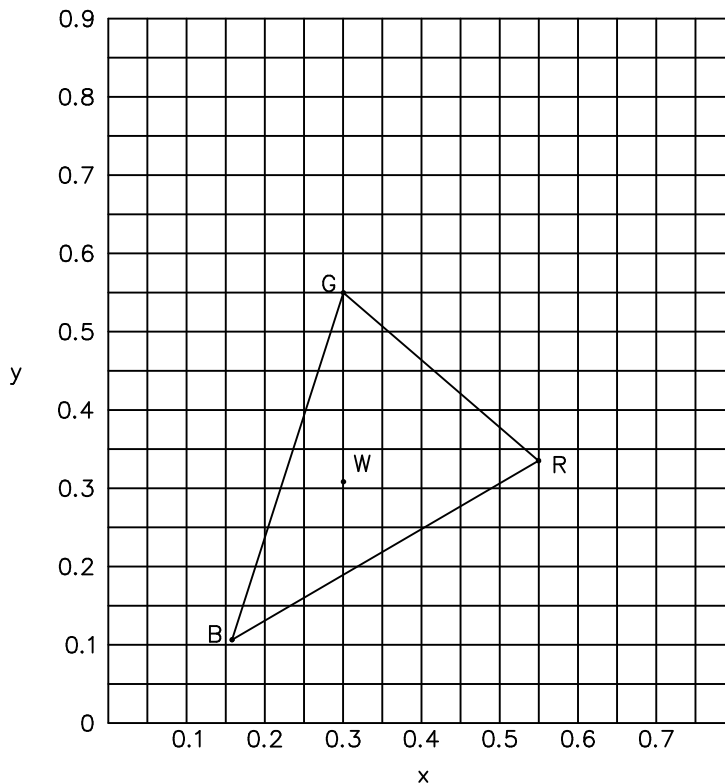

(NOTE 1)

Definition of Operation Voltage(Vop)

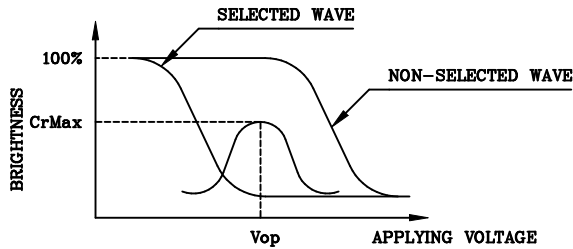

(positive type)

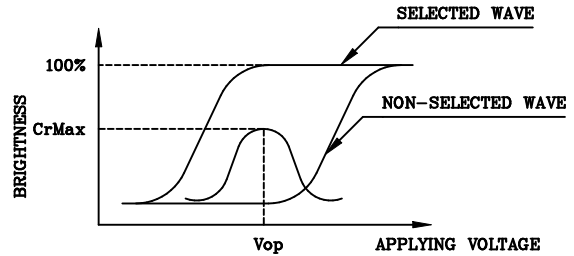

(negative type)

*Conditions

Viewing Angle : 0
Frame Frequency : 120Hz
Applying Waveform : 1/N duty 1/a bias

(NOTE 2)

Definition of Response Time(Tr,Tf)

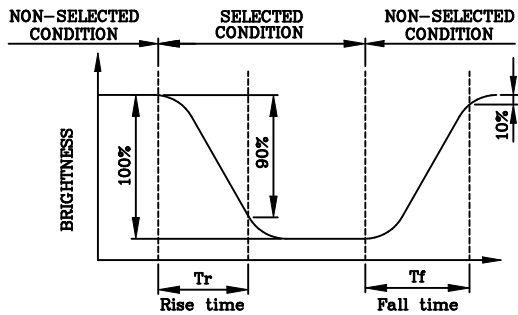

(positive type)

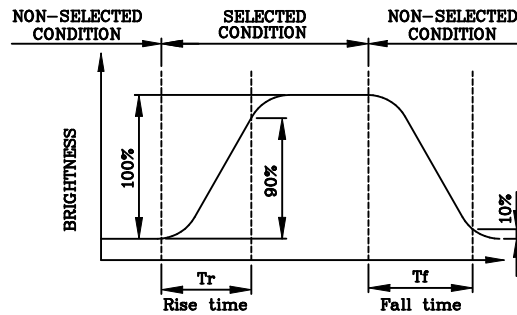

(negative type)

*Conditions

Operating Voltage : Vop
Viewing Angle (θ,φ) : (0,0)
Frame Frequency : 120Hz
Applying Waveform : 1/N duty 1/a bias

(NOTE 3)

Description of Measuring Equipment and Driving Waveforms

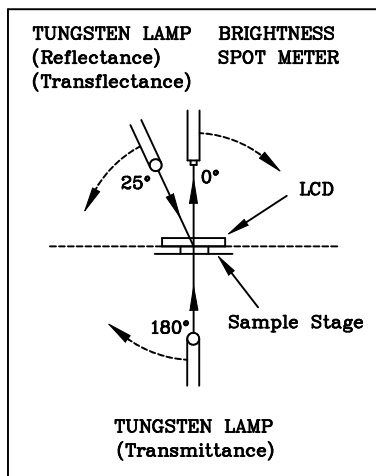

CONST.
TEMP.
CHAMBER

Multiplex Driving (1/N duty 1/a bias)

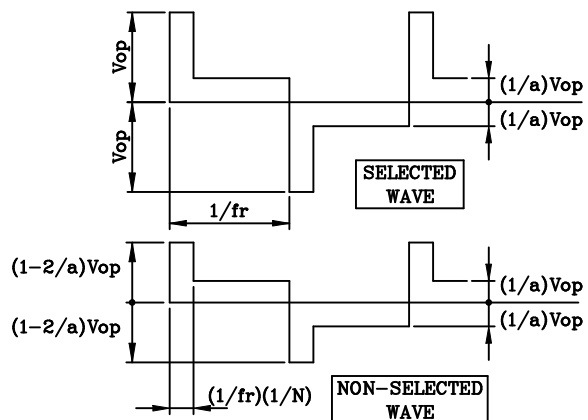

(NOTE 4)

Definition of Viewing Direction

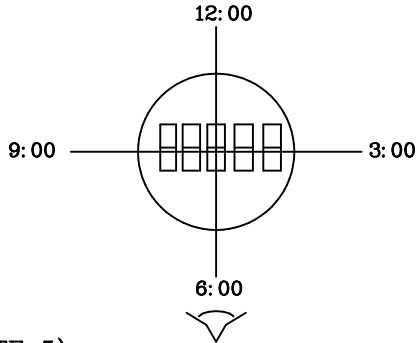

(NOTE 5)

Definition of Viewing Angle

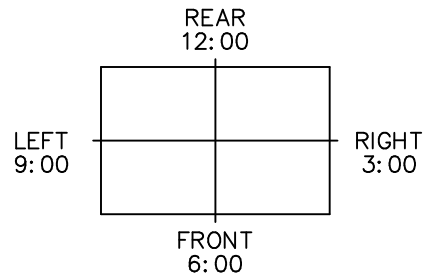
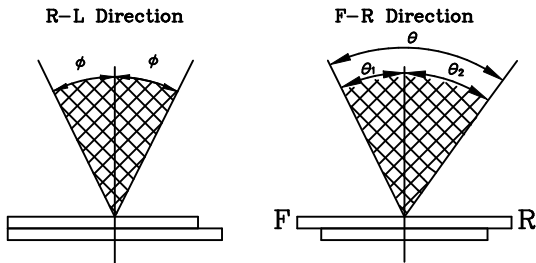

*For This Product
 The Viewing Direction Is 6 O'clock
 So $\theta_1 > \theta_2$

$$\theta = \theta_1 + \theta_2$$

*Conditions

Operating Voltage : V_{op}
 Frame Frequency : 120Hz
 Applying Waveform : 1/N duty 1/a bias
 Contrast Ratio : larger than 2

(NOTE 6)

Definition of Contrast Ratio (Cr)

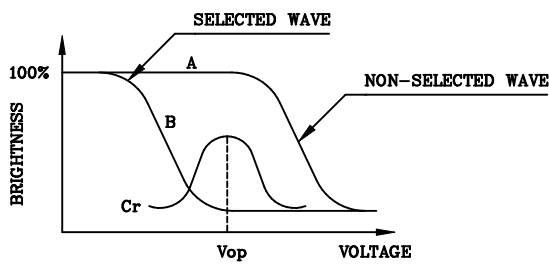

(positive type)

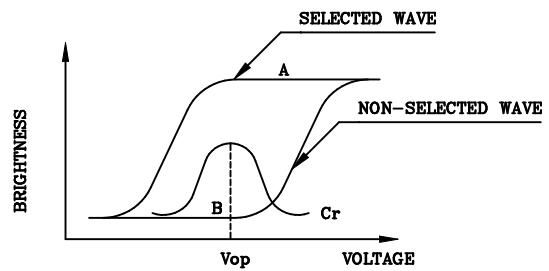

(negative type)

$$\text{Contrast Ratio : } Cr = A/B$$

*Conditions

Viewing Angle : 0
 Frame Frequency : 120Hz
 Applying Waveform : 1/N duty 1/a bias

5. BLOCK DIAGRAM

LCD

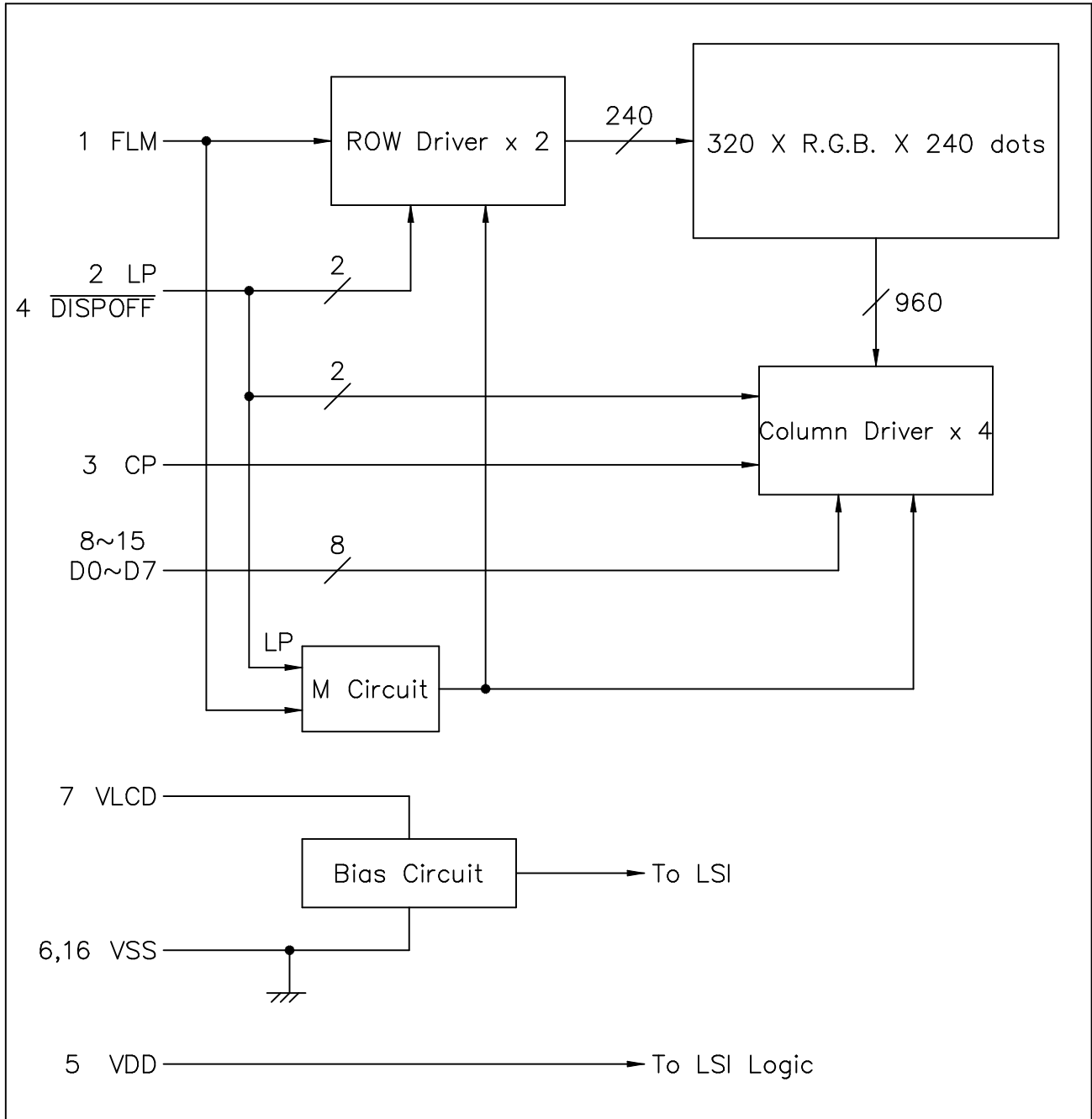

CCFL

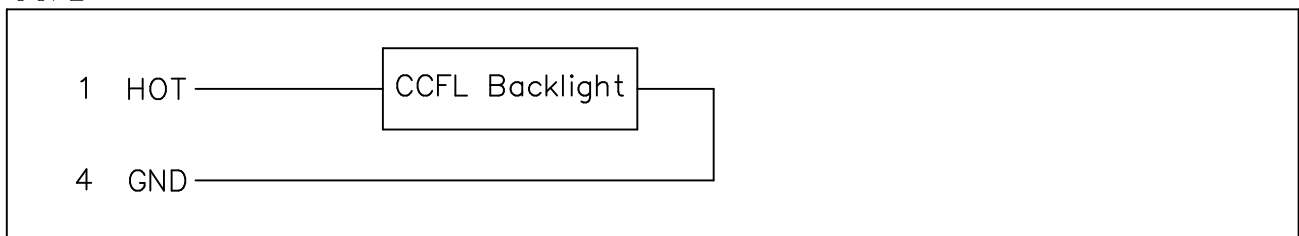

6. INTERNAL PIN CONNECTION

LCD

Pin No.	Symbol	Level	Function
1	FLM	H/L	First Line Marker
2	LP	H→L	Data Latch Signal
3	CP	H→L	Clock Signal for Shifting Data
4	DISPOFF	H/L	Display Control Signal, H :Display on L :Display off
5	VDD	-	Power Supply for Logic
6	VSS	-	Power Supply (0V,GND)
7	VLCD	-	Power Supply for LCD Drive
8	D0	H/L	Display Data
9	D1	H/L	Display Data
10	D2	H/L	Display Data
11	D3	H/L	Display Data
12	D4	H/L	Display Data
13	D5	H/L	Display Data
14	D6	H/L	Display Data
15	D7	H/L	Display Data
16	VSS	-	Power Supply (0V,GND)

LCD INTERFACE CABLE : FFC,N16,Pitch 1.0 mm (Thickness = 0.3 mm)

MATING CONNECTOR : MOLEX 52207-1685 or COMPATIBLE

CCFL

Pin No.	Symbol	Level	Function
1	HOT	-	Power Supply for CCFL(HOT)
2	NC	-	Non-connection
3	NC	-	Non-connection
4	GND	-	Power Supply for CCFL(GND)

CCFL CONNECTOR : M63M83-04 (MITSUMI)

MATING CONNECTOR : M60-04-30-134P or M60-04-30-114P or M61M73-04(MITSUMI)

TOUCH SCREEN

Pin No.	Symbol	Level	Function
1	UP	-	Up Direction
2	RIGHT	-	Right Direction
3	DOWN	-	Down Direction
4	LEFT	-	Left Direction

TOUCH SCREEN CABLE : N4,Pitch 1.0mm (Thikness = 0.3 mm)

Mating Connector : 52852-0470(molex)

7. POWER SUPPLY

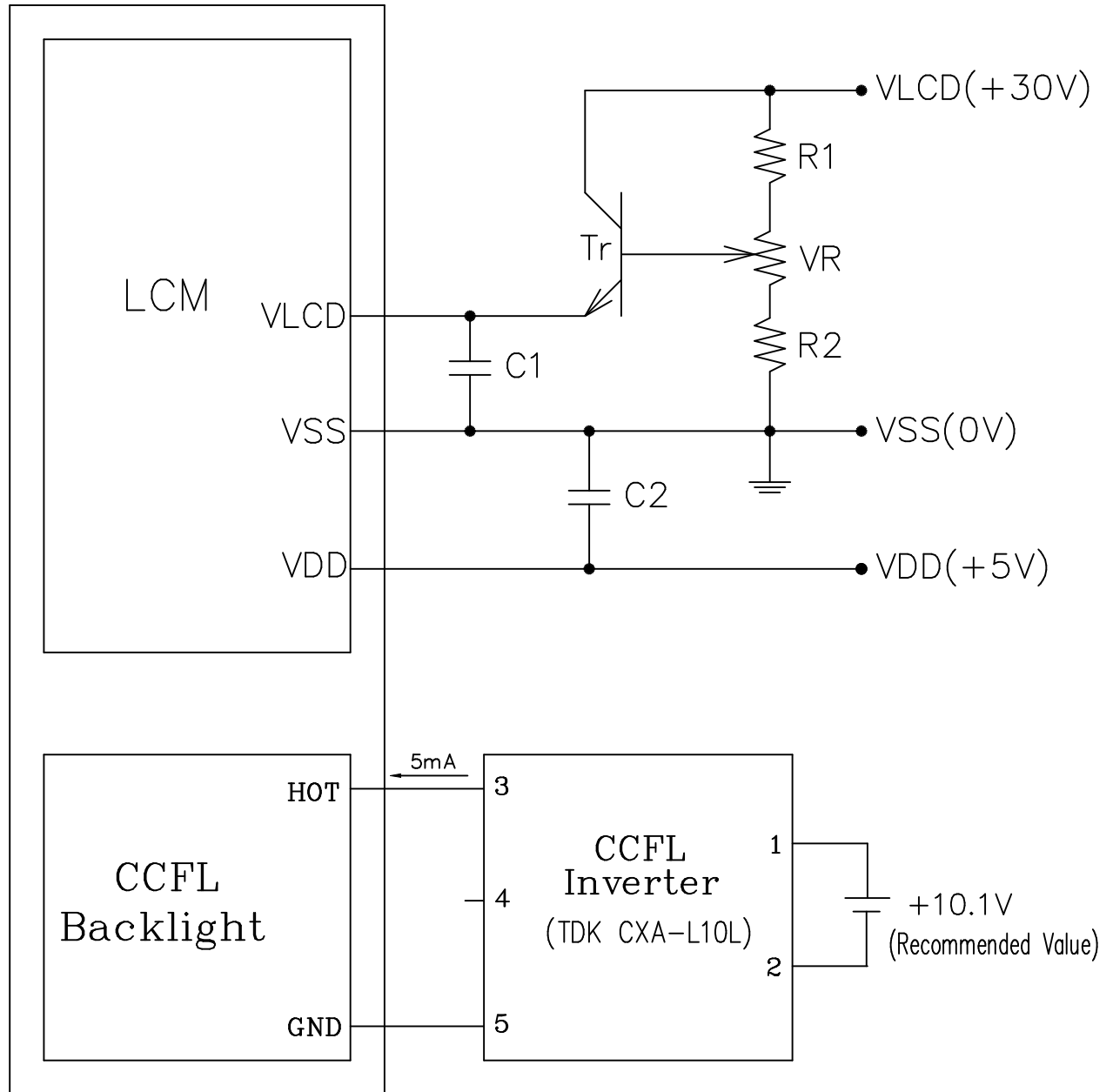

$$1. R1 + R2 + VR = 10 \sim 20K \Omega$$

$$C1, C2 = 10 \mu F$$

8. TIMING CHARACTERISTICS

8-1. INTERFACE TIMING

VDD=5.0V ± 10%

Parameter	SYMBOL	MIN.	MAX.	UNIT
CLOCK PULSE CYCLE TIME	t_{wck}	40	-	ns
CLOCK PULSE HIGH LEVEL WIDTH	t_{wckH}	12	-	ns
CLOCK PULSE LOW LEVEL WIDTH	t_{wckL}	14	-	ns
LATCH PULSE HIGH LEVEL WIDTH	t_{wLPH}	15	-	ns
CP→LP RISE TIME	t_{LD}	5	-	ns
CP→LP FALL TIME	t_{SL}	25	-	ns
LP→CP RISE TIME	t_{LS}	25	-	ns
LP→CP FALL TIME	t_{LH}	25	-	ns
CLOCK PULSE RISE/FALL TIME	t_r, t_f	-	50	ns
DATA SETUP TIME	t_{DS}	5	-	ns
DATA HOLD TIME	t_{DH}	15	-	ns
DISPOFF LOW LEVEL WIDTH	t_{WDL}	1.2	-	μs
DISPOFF CANCELLATION TIME	t_{SD}	100	-	ns
FLM SETUP TIME	t_{SU}	30	-	ns
FLM HOLD TIME	t_H	50	-	ns

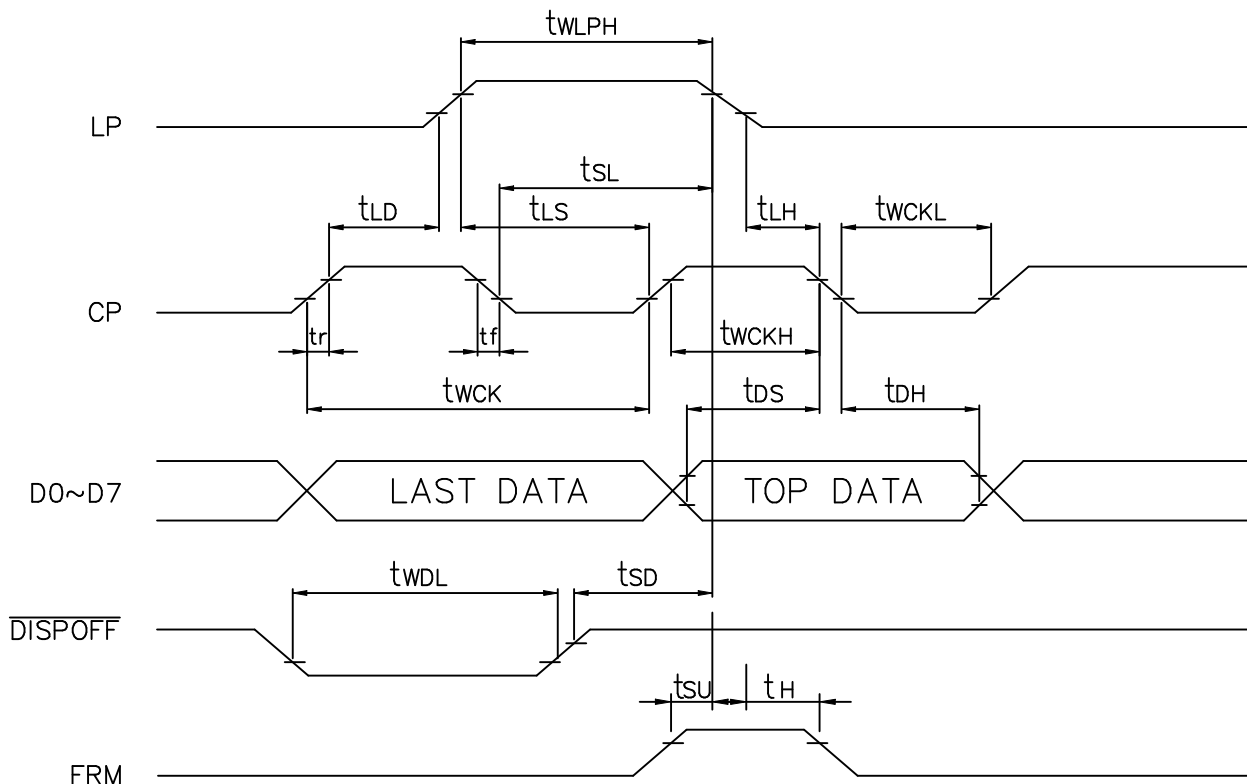

8-2. TIMING CHART OF INPUT SIGNAL

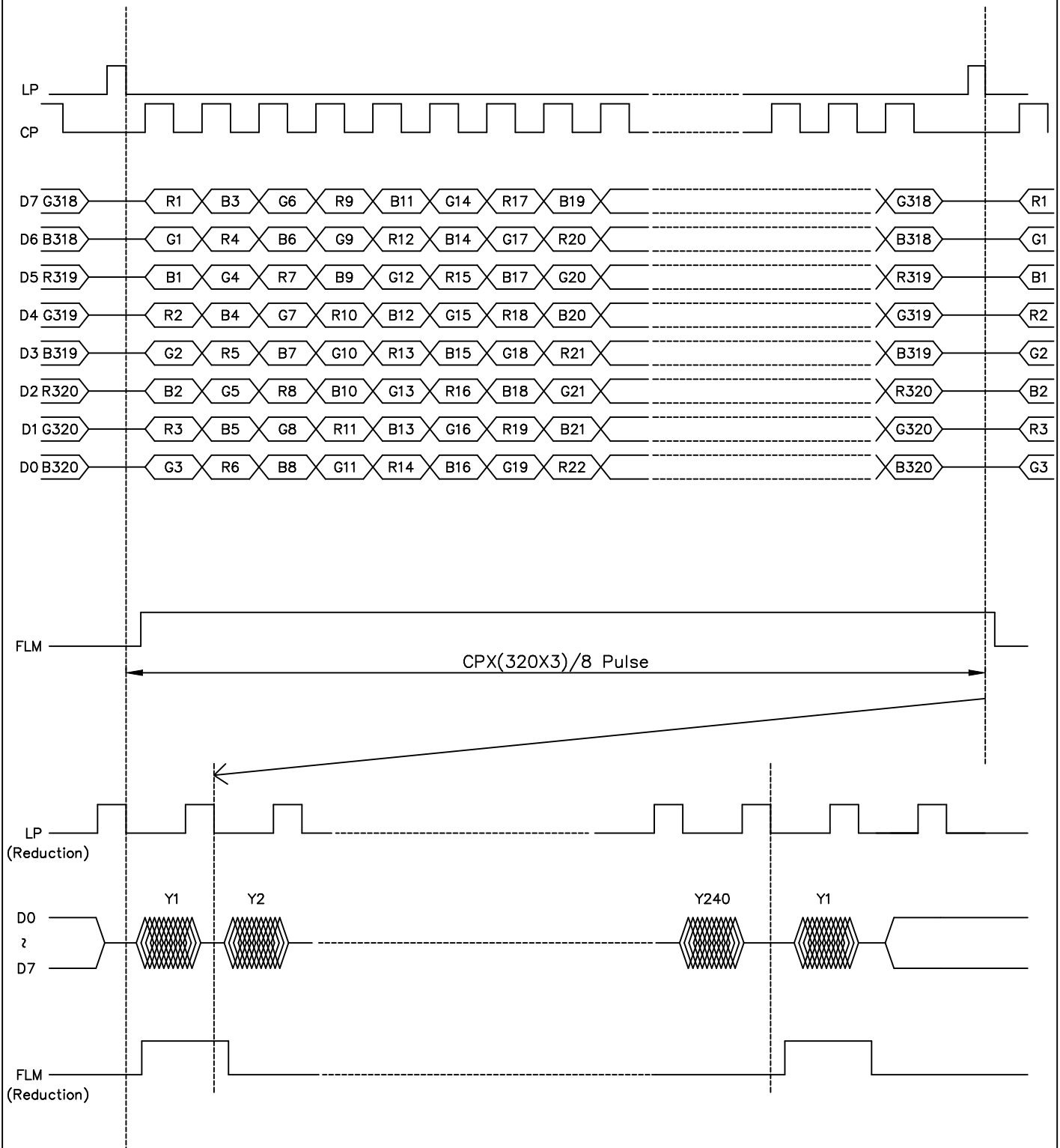

8-3. POWER ON/OFF TIMING

ON SEQUENCE

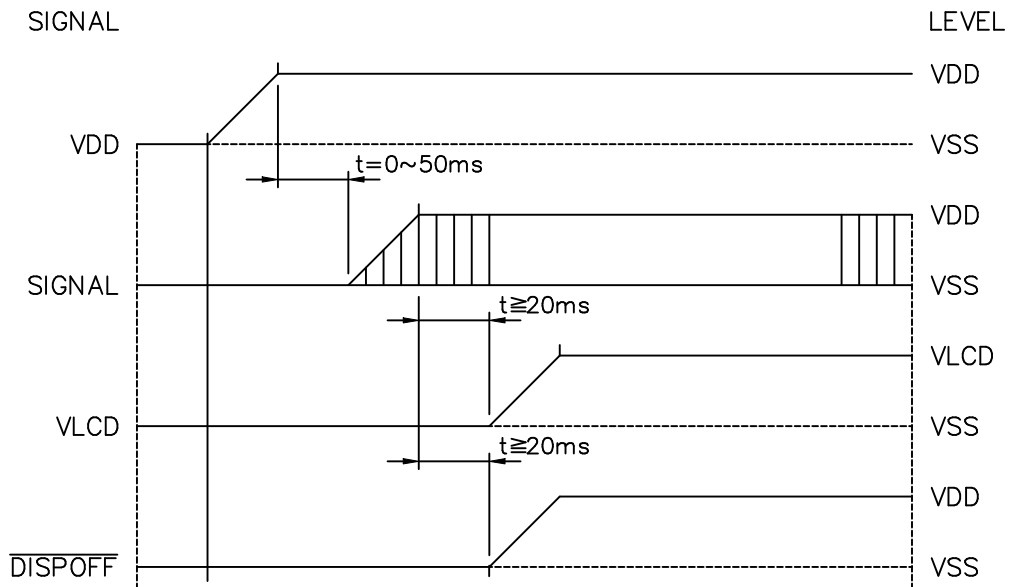

OFF SEQUENCE

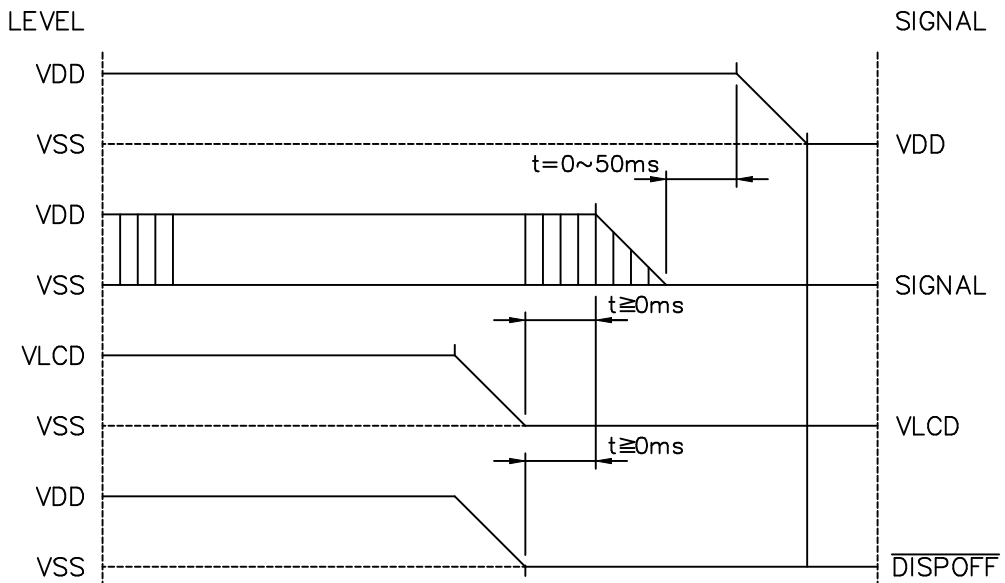

Please maintain the above sequence when turning on and off the power supply of the module. If $\overline{\text{DISPOFF}}$ is supplied to the module while internal alternate signal for LCD driving(M) is unstable, DC component will be supplied to the LCD panel. This may cause damage the LCD module.

8-4.DISPLAY PATTERN

STARTING DOT

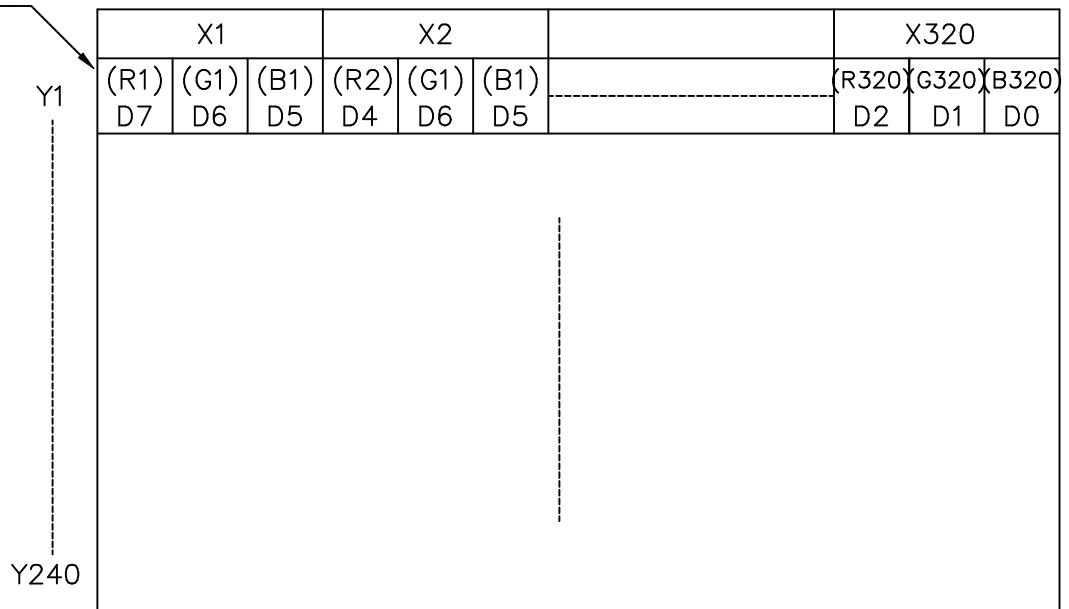

D0~D7 are 8 bits transmitted data, where D0 is LSB and D7 is MSB.

9. RELIABILITY TEST

NORMAL TEMPERATURE RELIABILITY TEST

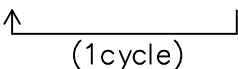
NO	ITEM	CONDITION		STANDARD	NOTE
1	High Temp. Storage	70°C	120Hrs	Appearance without defect	
2	Low Temp. Storage	-20°C	120Hrs	Appearance without defect	
3	High Temp. & High Humi. Storage	50°C 90%RH	120Hrs	Appearance without defect	
4	High Temp. Operating Display	50°C	120Hrs	Appearance without defect	
5	Low Temp. Operating Display	0°C	120Hrs	Appearance without defect	
6	Thermal Shock	-20°C, 30min → 70°C, 30min  (1cycle)		Appearance without defect	10 cycles

Inspection Provision

1. Purpose

The NAN YA inspection provision provides outgoing inspection provision and its expected quality level based on our outgoing inspection of NAN YA LCD produces.

2. Applicable Scope

The NAN YA inspection provision is applicable to the arrangement in regard to outgoing inspection and quality assurance after outgoing.

3. Technical Terms

3-1 NAN YA Technical Terms

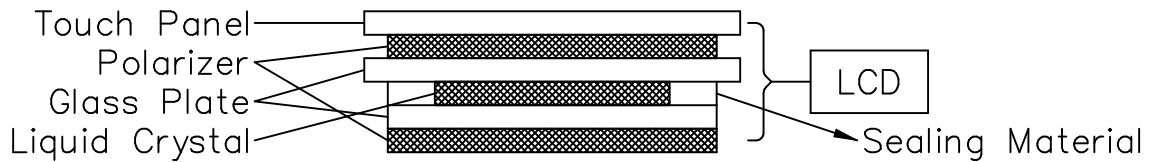

4. Outgoing Inspection

4-1 Inspection Method

MIL-STD-105E Level II Regular inspection

4-2 Inspection Standard

	Item		AQL(%)	Remarks
Major Defect	Dots	Opens Shorts Erroneous operation	0.4	faults which substantially lower the practicality and the initial purpose difficult to achieve.
	Solder appearance	Shorts Loose		
	Cracks	Display surface cracks		
	Touch Panel contact resistance			
	Touch Panel input load			

	Touch Panel linearity		0.4	
	Dimensions	External from Dimensions	0.4	
Minor Defect	Inside the glass	Black spots	0.65	faults which appear to pose almost no obstacle to the practicality, effective use, and operation.
	Polarizing plate	Scratches, foreign Matter, air bubbles, and peeling		
	Dots	Pinhole, deformation		
	Color tone	Color unevenness		
	Solder appearance	Cold solder Solder projections		

4-3 Inspection Provisions
*Viewing Area Definition

Fig. 1

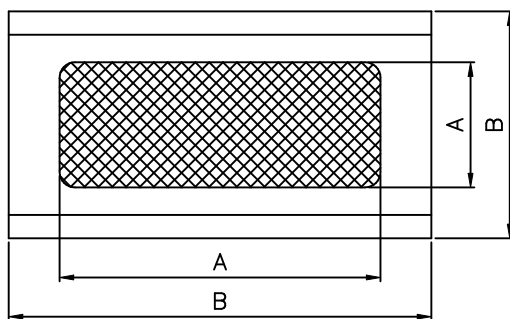

A : Zone Viewing Area
B : Zone Glass Plate Outline

*Inspection place to be 500 to 1000 lux illuminance uniformly without glaring.
The distance between luminous source(daylight fluorescent lamp and cool white fluorescent lamp) and sample to be 30cm to 50cm.

*Test and measurement are performed under the following conditions, unless otherwise specified.

Temperature 20± 15°C
Humidity 65± 20%R.H.
Pressure 860~1060hPa(mmbar)

In case of doubtful judgment, it is performed under the following conditions.

Temperature 20± 2°C
Humidity 65± 5%R.H.
Pressure 860~1060hPa(mmbar)

5.Specification for quality check
5-1 Electrical characteristics

NO.	Item	Criterion
1	Non operational	Fail
2	Miss operating	Fail
3	Missing dot	Fail
4	Contrast irregular	Fail
5	Response time	Within Specified value
6	Touch Panel contact resistance	Within Specified value
7	Touch Panel input load	Within Specified value
8	Touch Panel linearity	Within Specified value
9	Backlight turn on/off	Within Specified value

5-2 External Appearance Defect

NO.	Item	Criterion																							
1	Black spots, foreign matter, and white spots (Including light leakage due to pinholes of polarizing plates, etc.)	<p>(1)-1-Spots</p> <table border="1" data-bbox="703 488 1398 817"> <thead> <tr> <th>Average Diameter(mm):D</th> <th>Number of pieces permitted</th> <th>Minimum Space</th> </tr> </thead> <tbody> <tr> <td>$D \leq 0.2$</td> <td>Ignore</td> <td>-</td> </tr> <tr> <td>$0.2 < D \leq 0.3$</td> <td>5</td> <td>10mm</td> </tr> <tr> <td>$0.3 < D \leq 0.4$</td> <td>2</td> <td>30mm</td> </tr> <tr> <td>$0.4 < D$</td> <td>0</td> <td></td> </tr> </tbody> </table> <p>Number of total pieces is set to within 5 pieces.</p> <p>Note that when there are 2 pieces or more, they are not to be concentrated. Set as: Average diameter = (Long diameter + Short diameter)/2</p> <p>(1)-2-Blurred Spots(At lighting condition)</p> <table border="1" data-bbox="703 1234 1334 1464"> <thead> <tr> <th>Average Diameter(mm):D</th> <th>Number of pieces permitted</th> </tr> </thead> <tbody> <tr> <td>$D \leq 0.3$</td> <td>Ignore</td> </tr> <tr> <td>$0.3 < D \leq 0.75$</td> <td>5</td> </tr> <tr> <td>$0.75 < D$</td> <td>0</td> </tr> </tbody> </table> <p>Number of total pieces is set to within 5 pieces.</p> <p>Note that when there are 2 pieces or more, they are not to be concentrated. Set as: Average diameter = (Long diameter + Short diameter)/2</p>	Average Diameter(mm):D	Number of pieces permitted	Minimum Space	$D \leq 0.2$	Ignore	-	$0.2 < D \leq 0.3$	5	10mm	$0.3 < D \leq 0.4$	2	30mm	$0.4 < D$	0		Average Diameter(mm):D	Number of pieces permitted	$D \leq 0.3$	Ignore	$0.3 < D \leq 0.75$	5	$0.75 < D$	0
Average Diameter(mm):D	Number of pieces permitted	Minimum Space																							
$D \leq 0.2$	Ignore	-																							
$0.2 < D \leq 0.3$	5	10mm																							
$0.3 < D \leq 0.4$	2	30mm																							
$0.4 < D$	0																								
Average Diameter(mm):D	Number of pieces permitted																								
$D \leq 0.3$	Ignore																								
$0.3 < D \leq 0.75$	5																								
$0.75 < D$	0																								

1	Line	<p>(1)-1-Lines</p> <table border="1" data-bbox="702 443 1433 721"> <thead> <tr> <th>Width(mm): W</th> <th>Length(mm): L</th> <th>Number of pieces permitted</th> </tr> </thead> <tbody> <tr> <td>$W \leq 0.03$</td> <td>Ignore</td> <td>Ignore</td> </tr> <tr> <td>$0.03 < W \leq 0.08$</td> <td>$L \leq 4$</td> <td>2</td> </tr> <tr> <td>$0.08 < W \leq 0.1$</td> <td>$L \leq 1$</td> <td>1</td> </tr> </tbody> </table> <p>Object exceeding 0.1mm follow the standards of the spots form. Note that when there are 2 pieces or more, they are not to be concentrated.</p> <p>(1)-2-Blurred Lines(At lighting condition)</p> <table border="1" data-bbox="702 1019 1433 1296"> <thead> <tr> <th>Width(mm): W</th> <th>Length(mm): L</th> <th>Number of pieces permitted</th> </tr> </thead> <tbody> <tr> <td>$W \leq 0.03$</td> <td>Ignore</td> <td>Ignore</td> </tr> <tr> <td>$0.03 < W \leq 0.08$</td> <td>$L \leq 3$</td> <td>6</td> </tr> <tr> <td>$0.08 < W$</td> <td>$3 < L$</td> <td>None</td> </tr> </tbody> </table> <p>Object exceeding 0.1mm follow the standards of the spots form. Note that when there are 2 pieces or more, they are not to be concentrated.</p>	Width(mm): W	Length(mm): L	Number of pieces permitted	$W \leq 0.03$	Ignore	Ignore	$0.03 < W \leq 0.08$	$L \leq 4$	2	$0.08 < W \leq 0.1$	$L \leq 1$	1	Width(mm): W	Length(mm): L	Number of pieces permitted	$W \leq 0.03$	Ignore	Ignore	$0.03 < W \leq 0.08$	$L \leq 3$	6	$0.08 < W$	$3 < L$	None
Width(mm): W	Length(mm): L	Number of pieces permitted																								
$W \leq 0.03$	Ignore	Ignore																								
$0.03 < W \leq 0.08$	$L \leq 4$	2																								
$0.08 < W \leq 0.1$	$L \leq 1$	1																								
Width(mm): W	Length(mm): L	Number of pieces permitted																								
$W \leq 0.03$	Ignore	Ignore																								
$0.03 < W \leq 0.08$	$L \leq 3$	6																								
$0.08 < W$	$3 < L$	None																								
2	Scratches(Glass, reflection plates, and polarizing plates)	In accordance with black spots. (At non lighting condition)																								
3	Color irregular	Not remarkable color irregular.																								

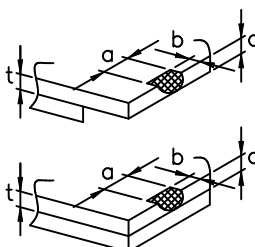
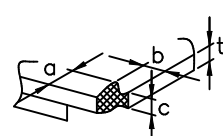
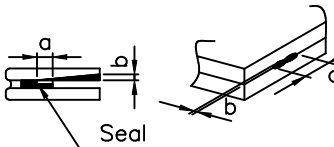
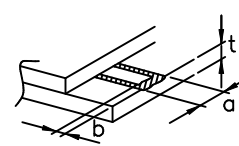
4	Air bubbles polarizing plates, and reflection plates	<table border="1" style="width: 100%; border-collapse: collapse;"> <tr> <td style="width: 30%; text-align: center;">Average Diameter (mm): D</td> <td style="width: 30%; text-align: center;">Number of pieces permitted</td> <td rowspan="2" style="width: 40%; vertical-align: middle;">Average diameter = (Long diameter + Short diameter)/2</td> </tr> <tr> <td style="text-align: center;">D ≤ 0.3 0.3 < D</td> <td style="text-align: center;">Ignore 0</td> </tr> </table> <p>Note that when there are 4 pieces or more, they are not to be concentrated.</p>		Average Diameter (mm): D	Number of pieces permitted	Average diameter = (Long diameter + Short diameter)/2	D ≤ 0.3 0.3 < D	Ignore 0
Average Diameter (mm): D	Number of pieces permitted	Average diameter = (Long diameter + Short diameter)/2						
D ≤ 0.3 0.3 < D	Ignore 0							
5	Cracks	<p>(1) General crack</p> 	<p>$a \leq 5$ $b \leq 2$ $c \leq t$</p> <p>Where, a and b are ignored when less than or equal to 0.5 The numbers of pieces are set at up to 5 pieces.</p>					
		<p>(2) Corner crack</p> 	<p>$a \leq 2.5$ $b \leq 2.5$ $c \leq t$ $a + b \leq 4$</p>					
		<p>(3) Seal portion crack</p> 	<p>$a \leq \text{The seal width} \times 1/3$ $b \leq t \times 2/3$ $c \leq 5$</p> <p>The numbers of pieces are set at up to 5 pieces.</p>					
		<p>(4) ITO Pin crack</p> 	<p>$a \leq 5$ $b \leq 1/3 \text{ pin length}$ $c \leq t$</p>					
		<p>(5) Progressive cracks</p>	<p>All taken to be unacceptable.</p>					

6	Outer dimensions	Should be within the tolerance.
7	Newton ring(touch panel)	Orbicular of interference fringes is not allowed in the optimum contrast within the active area under viewing angle.
8	Soldering	Should be no defective soldering such as shorting, loose terminal cold solder, peeling of printed circuit board pattern, improper mounting position, etc.

5-3 Dot Appearance Defect

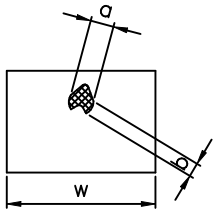
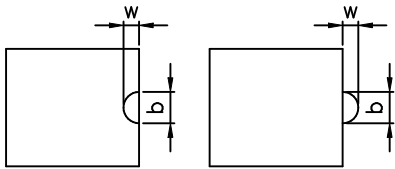
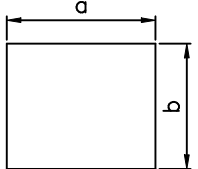
NO.	Item	Criteria
1	Pinhole	 <p>Dot display a and b are each $\leq 0.2\text{mm}$ The overall total is taken be with in 10 units. Note that they are not to be concentrated.</p>
2	Missing	 <p>Dot display a and b are each $\leq 0.2\text{mm}$ The overall total is taken to be with in 10 units.</p>
3	Thick and thin display	 <p>Taken to be within $\pm 1.5\%$ of display character width(a) and height(b).</p>

NOTICE:

- SAFETY

- 1.If the LCD panel breaks, be careful not to get the liquid crystal to touch your skin.
- 2.If the liquid crystal touches your skin or clothes, please wash it off immediately by using soap and water.

- HANDLING

- 1.Avoid static electricity which can damage the CMOS LSI.
- 2.Do not remove the panel or frame from the module.
- 3.The polarizing plate of the display is very fragile. So, please handle it very carefully.
- 4.Do not wipe the polarizing plate with a dry cloth, as it may easily scratch the surface of plate.
- 5.Do not use ketonics solvent & Aromatic solvent. Use a soft cloth soaked with a cleaning naphtha solvent.

- STORAGE

- 1.Store the panel or module in a dark place where the temperature is $25^{\circ}\text{C}\pm 5^{\circ}\text{C}$ and the humidity is below 65% RH.
- 2.Do not place the module near organics solvents or corrosive gases.
- 3.Do not crush, shake, or jolt the module.

- TERMS OF WARRANT

- 1.Acceptance inspection period
The period is within one month after the arrival of contracted commodity at the buyer's factory site.
- 2.Applicable warrant period
The period is within twelve months since the date of shipping out under normal using and storage conditions.

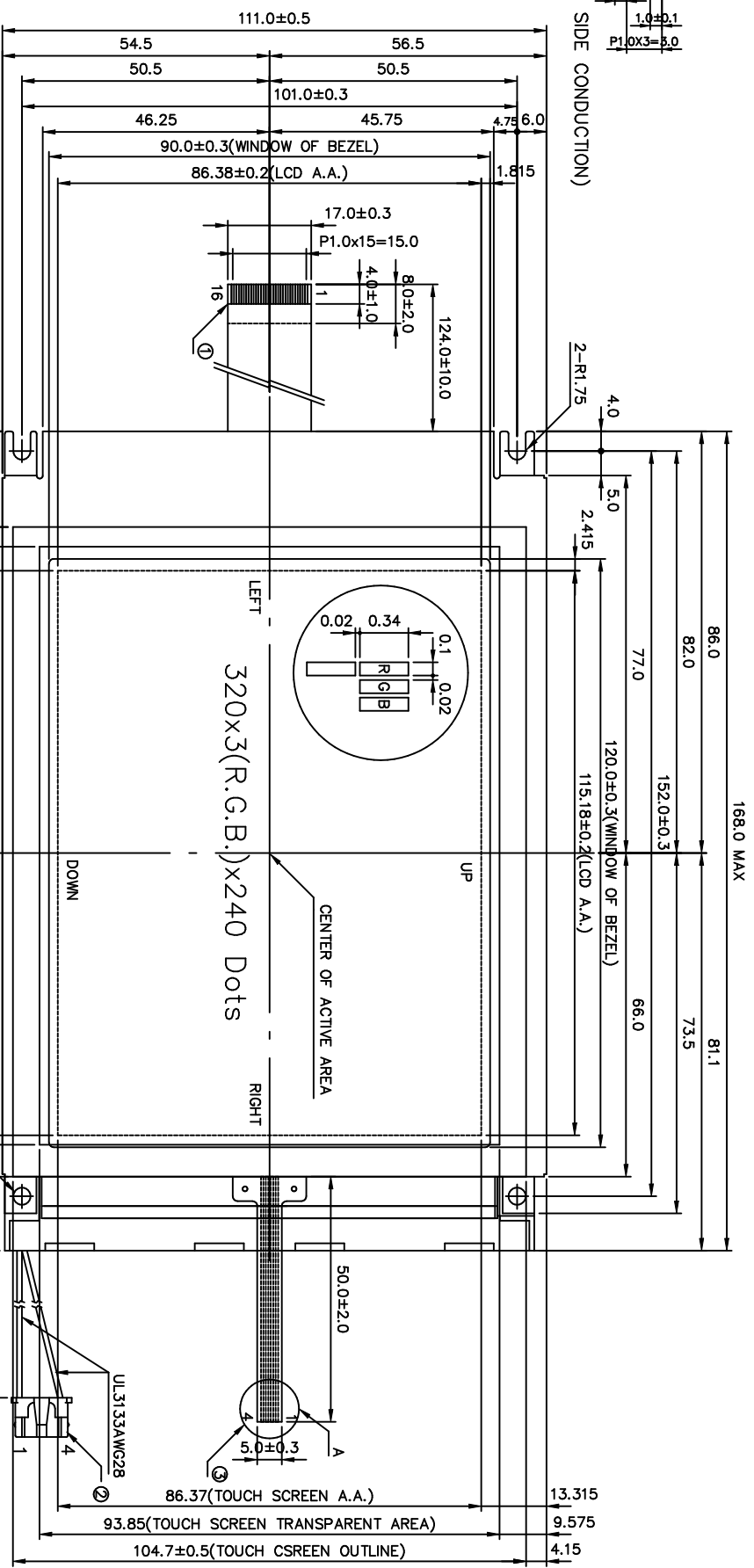
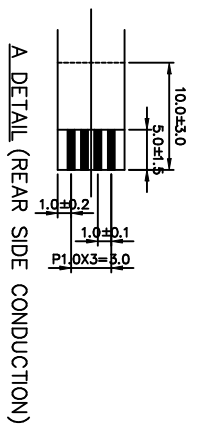

① PIN ASSIGNMENT OF I/O CONNECTION

Pin No.	SYMBOL	LEVEL	FUNCTION
1	FLM	H/L	First Line Worker
2	LP	H-L	Data Latch Signal
3	CP	H-L	Data Shift Clock Signal
4	DISP OFF	H/L	H : Display On L : Display Off
5	VDD	-	Power Supply for Logic
6	VSS	-	Power Supply (0V/GND)
7	VDD	-	Power Supply for LCD Drive
8	D0	H/L	Display Data
9	D1	H/L	Display Data
10	D2	H/L	Display Data
11	D3	H/L	Display Data
12	D4	H/L	Display Data
13	D5	H/L	Display Data
14	D6	H/L	Display Data
15	D7	H/L	Display Data
16	VSS	-	Power Supply (0V/GND)

② PIN ASSIGNMENT OF CCFL CONNECTION

Pin No.	SYMBOL	LEVEL	FUNCTION
1	HOT	-	Power Supply for CCFL(HOT)
2	NC	-	No Connection
3	NC	-	No Connection
4	GND	-	Power Supply for CCFL(GND)

③ PIN ASSIGNMENT OF TOUCH PANEL CONNECTION

Pin No.	Symbol	Signal Level	Function
1	UP	-	Up Direction
2	RIGHT	-	Right Direction
3	DOWN	-	Down Direction
4	LEFT	-	Left Direction

- NOTE :
1. RESOLUTION : 320 X 3(R.G.B.) X 240 DOTS
 2. CONTROLLER : EXCLUDED
 3. DC/DC CONVERTER : EXCLUDED
 4. INTERFACE CONNECTOR
FFC, N16 P1.0mm
 5. TOLERANCE NO SPECIFIED : ±0.5mm

VIEWING DIRECTION



GENERAL TOLERANCE LIST

DIMENSION	TOLERANCE
L ≤ 6	±0.25 (mm)
6 < L ≤ 18	±0.3 (mm)
18 < L ≤ 50	±0.4 (mm)
50 < L ≤ 125	±0.5 (mm)
125 < L	±0.6 (mm)
ANGLE	±1° (DEG)

南亞塑膠工業股份有限公司
NAN YA PLASTICS CORPORATION
製品圖

LCBHBTB61M2S

REV. NO.	DESCRIPTION	DATE	DESIGN	CHECK	APPROVE

DWG NO.	NAME	DATE	THIRD ANGLE P.
MB61AD2A			

APPROVE	CHECK	DESIGN	DRAWN	SCALE	UNIT

THE NOTES OF LCM USING

LCM is easy to damage.

Please follow the notes as bellows, and be careful of handling!

Correct handling

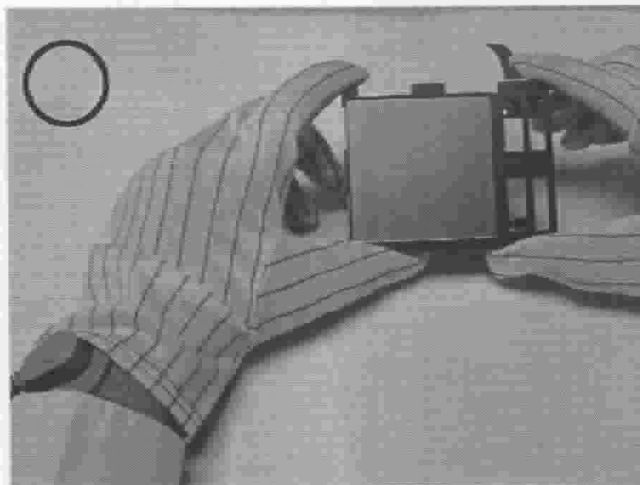
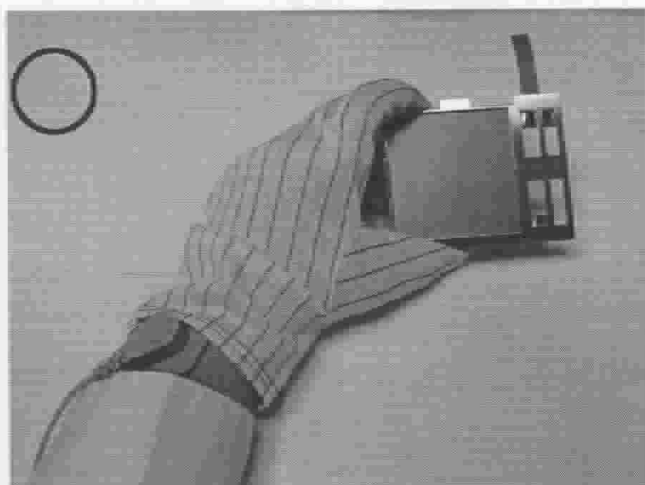

As above picture, please handle with glove by LCM edges and full EOS/ESD protection.

Incorrect handling

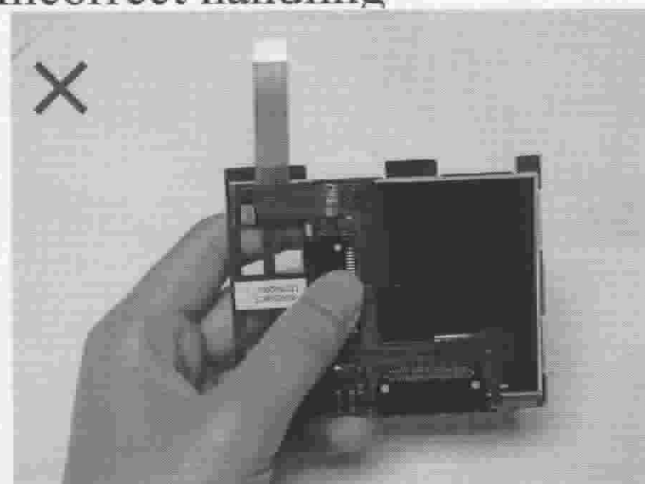

Please don't touch IC directly.

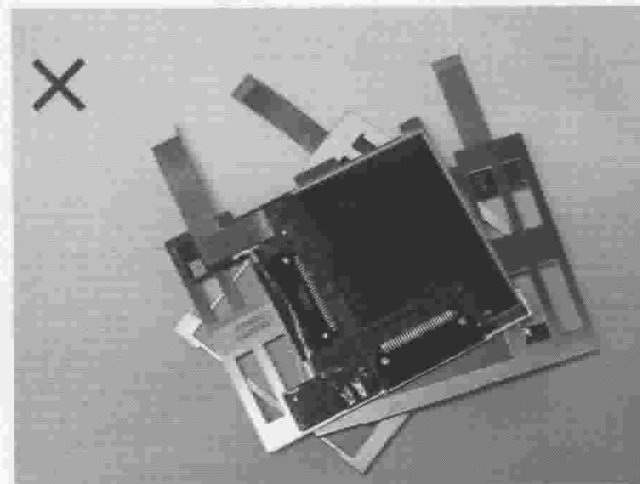

Please don't put one on another LCM.

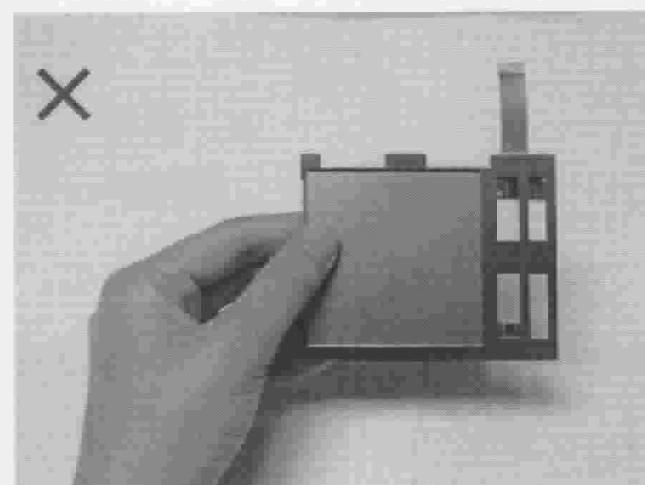

Please don't hold the surface of LCM.

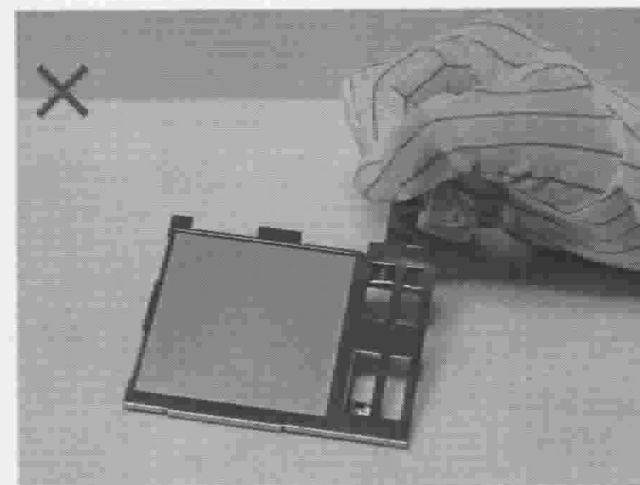

Please don't stretch interface of output.

THE NOTES OF LCD USING

LCD is easy damage.

Please follow notes as bellows, and be careful of handling!

Correct handling

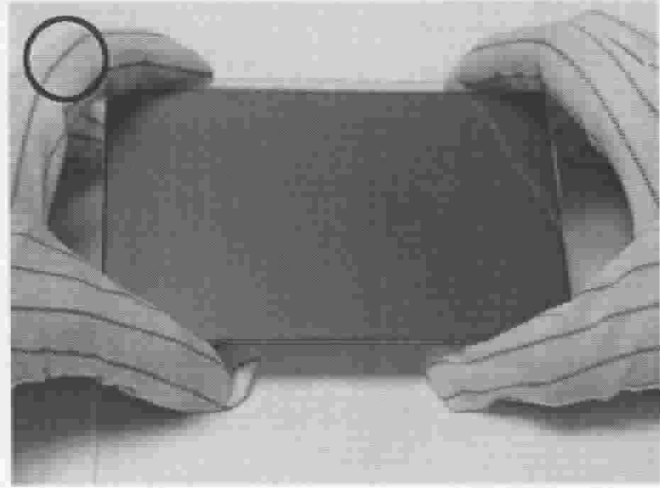
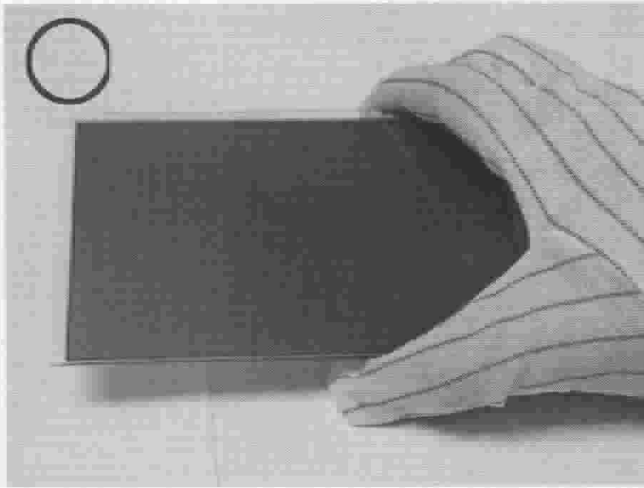

As above picture, please handle with glove by LCD edges and full EOS/ESD protection.

Incorrect handling

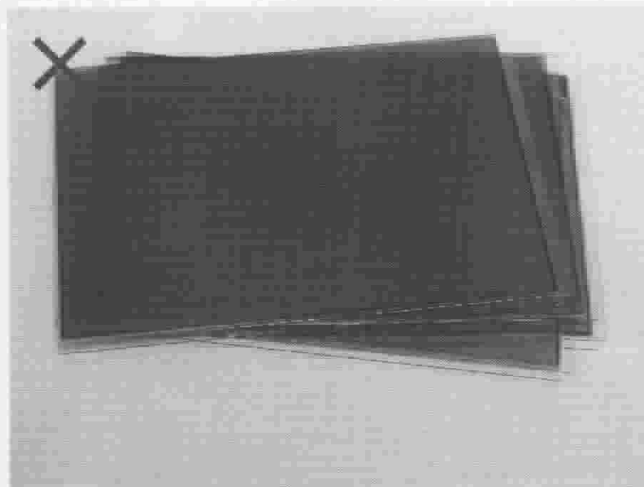

Please don't put one on another LCD.

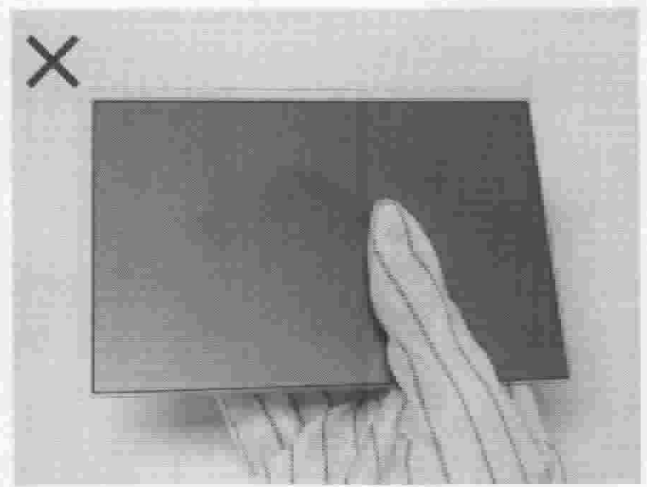

Please don't hold the surface of LCD.

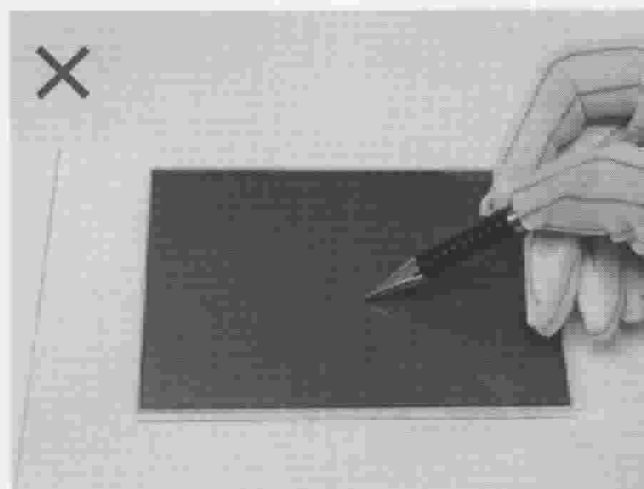

Please don't operate with sharp stick such as sharp pencil.

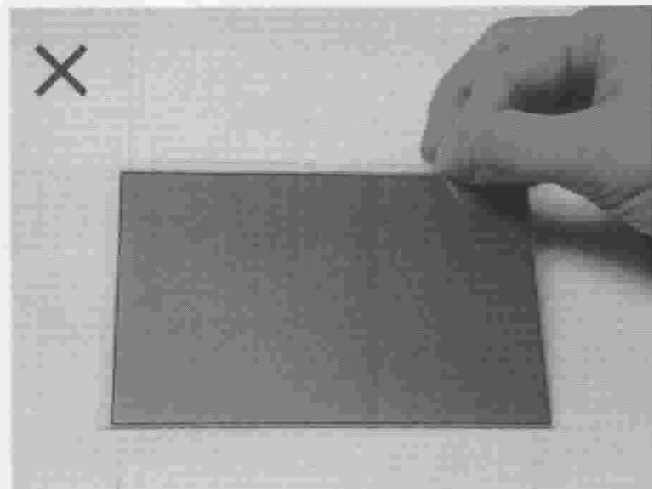

Please don't touch ITO glass without anti-static gloves.

