



**File No**

**SERVICE MANUAL**

**LCD-22VT11DVD**

**LCD TV DVD built-in**

PRODUCT No.  
**168235089**

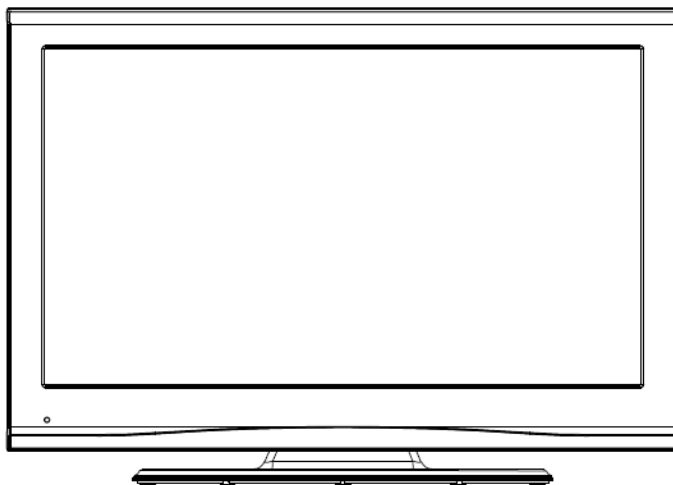

REFERENCE No.  
**SM0948002**

## CONTENTS

Safety precautions.....	
Alignment instructions .....	
Method of software upgrading.....	
Working principle analysis of the unit.....	
Block diagram.....	
IC block diagram.....	
Wiring diagram .....	
Troubleshooting guide .....	
Schematic diagram.....	
APPENDIX-A: Assembly list	
APPENDIX-B: Exploded View	
Removing or Installing the Stand	
Wall mounting instructions	

**Attention:** This service manual is only for service personnel to take reference with. Before servicing please read the following points carefully.

## Safety precautions

### 1. Instructions

Be sure to switch off the power supply before replacing or welding any components or inserting/plugging in connection wire. Anti static measures to be taken (throughout the entire production process!):

- a) Do not touch here and there by hand at will;
- b) Be sure to use anti static electric iron;
- c) It's a must for the welder to wear anti static gloves.

Please refer to the detailed list before replacing components that have special safety requirements.

Do not change the specs and type at will.

### 2. Points for attention in servicing of LCD

2.1 Screens are different from one model to another and therefore not interchangeable. Be sure to use the screen of the original model for replacement.

2.2 The operation voltage of LCD screen is 700-825V. Be sure to take proper measures in protecting yourself and the machine when testing the system in the course of normal operation or right after the power is switched off. Please do not touch the circuit or the metal part of the module that is in operation mode. Relevant operation is possible only one minute after the power is switched off.

2.3 Do not use any adapter that is not identical with the TV set. Otherwise it will cause fire or damage to the set.

2.4 Never operate the set or do any installation work in bad environment such as wet bathroom, laundry, kitchen, or nearby fire source, heating equipment and devices or exposure to sunlight etc.

Otherwise bad effect will result.

2.5 If any foreign substance such as water, liquid, metal slices or other matters happens to fall into the module, be sure to cut the power off immediately and do not move anything on the module lest it

should cause fire or electric shock due to contact with the high voltage or short circuit.

2.6 Should there be smoke, abnormal smell or sound from the module, please shut the power off at

once. Likewise, if the screen is not working after the power is on or in the course of operation, the power must be cut off immediately and no more operation is allowed under the same condition.

2.7 Do not pull out or plug in the connection wire when the module is in operation or just after the power is off because in this case relatively high voltage still remains in the capacitor of the driving circuit. Please wait at least one minute before the pulling out or plugging in the connection wire.

2.8 When operating or installing LCD please don't subject the LCD components to bending, twisting

or extrusion, collision lest mishap should result.

2.9 As most of the circuitry in LCD TV set is composed of CMOS integrated circuits, it's necessary to pay attention to anti statics. Before servicing LCD TV make sure to take anti static measure and ensure full grounding for all the parts that have to be grounded.

2.10 There are lots of connection wires between parts behind the LCD screen. When servicing or moving the set please take care not to touch or scratch them. Once they are damaged the screen

**Attention:** This service manual is only for service personnel to take reference with. Before servicing please read the following points carefully.

2

would be unable to work and no way to get it repaired.

If the connection wires, connections or components fixed by the thermotropic glue need to

disengage when service, please soak the thermotropic glue into the alcohol and then pull them out in case of damage.

2.11 Special care must be taken in transporting or handling it. Exquisite shock vibration may lead to breakage of screen glass or damage to driving circuit. Therefore it must be packed in a strong case before the transportation or handling.

2.12 For the storage make sure to put it in a place where the environment can be controlled so as to prevent the temperature and humidity from exceeding the limits as specified in the manual. For prolonged storage, it is necessary to house it in an anti-moisture bag and put them altogether in one place. The ambient conditions are tabulated as follows:

Temperature	Scope for operation	0 ~ +50 °C
	Scope for storage	-20 ~ +60 °C
Humidity	Scope for operation	20% ~ 85%
	Scope for storage	10% ~ 90%

2.13 Display of a fixed picture for a long time may result in appearance of picture residue on the screen, as commonly called “ghost shadow”. The extent of the residual picture varies with the maker of LCD screen. This phenomenon doesn’t represent failure. This “ghost shadow” may remain in the picture for a period of time (several minutes). But when operating it please avoid displaying still picture in high brightness for a long time.

### **3. Points for attention during installation**

3.1 The front panel of LCD screen is of glass. When installing it please make sure to put it in place.

3.2 For service or installation it’s necessary to use specified screw lest it should damage the screen.

3.3 Be sure to take anti dust measures. Any foreign substance that happens to fall down between the screen and the glass will affect the receiving and viewing effect

3.4 When dismantling or mounting the protective partition plate that is used for anti vibration and insulation please take care to keep it in intactness so as to avoid hidden trouble.

3.5 Be sure to protect the cabinet from damage or scratch during service, dismantling or mounting.

## Alignment instructions

### 1. Test equipment

VG-848 (YPbPr, VGA signal generator)

VG-849 (HDMI signal generator)

CA210 (white balancer)

### 2. Power test

Connect power board, digital processing board, IR board and backlight board according the wiring diagram, connect the power and press to turn on the TV.

Test the pin voltage of X401, the data is shown in table1:

Table1 voltage data of X401

X401 Pin1 2 3 4 5, 6 7, 8 9 10 11 12 13

Voltage  $5V \pm 5\%$  0  $5V \pm 5\%$  0  $12V \pm 5\%$  0  $\leq 3.3V \leq 5V \leq 3.3V$   $32V \pm 5\%$  0

### 3. Alignment flow-chart

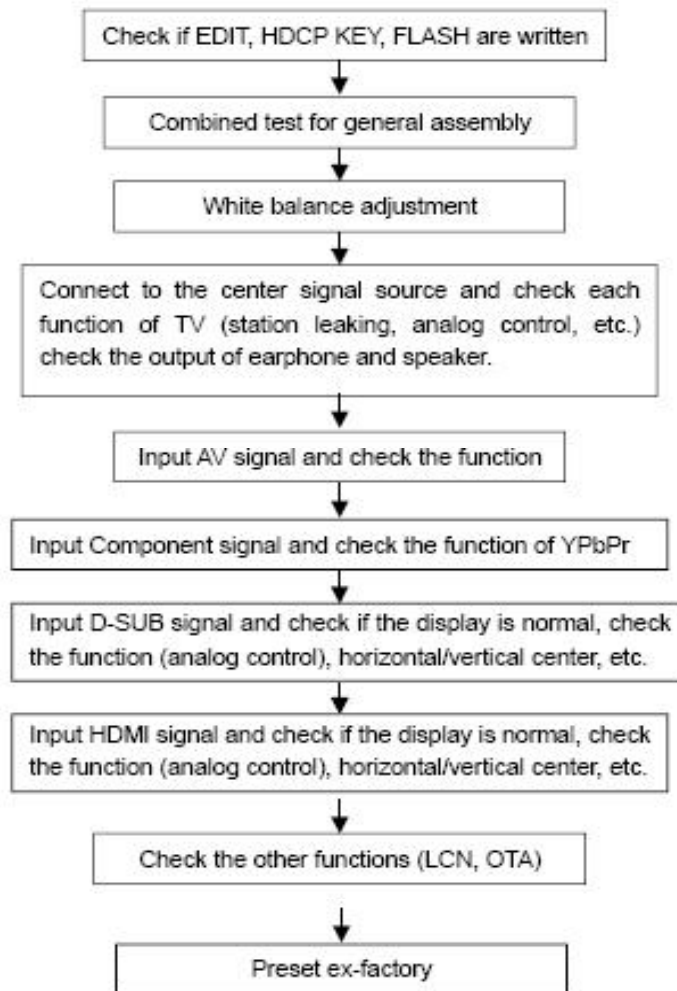
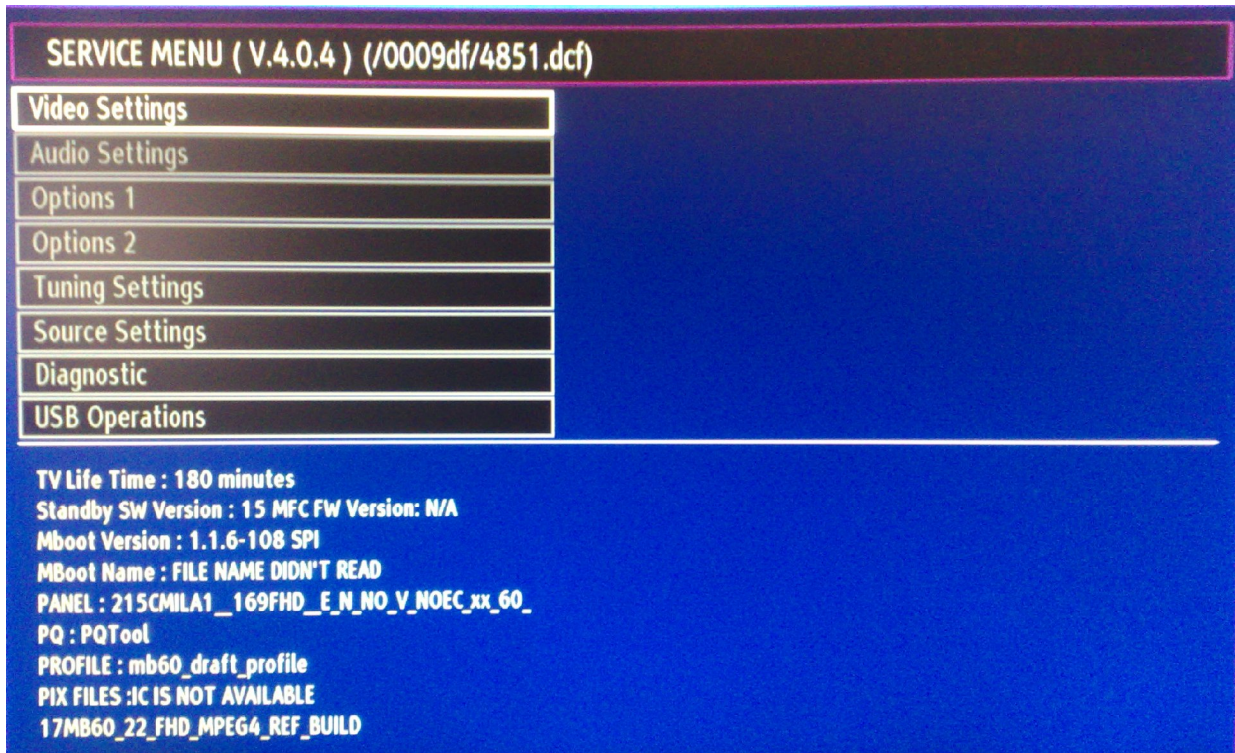

Fig-1 adjustment flow-chart

#### 4. Adjustment instruction













In order to reach service menu, First Press “MENU” Then press the remote control code two times, which is “4725”.



In first screen following items can be seen:



## 1.1. Video Settings

**VIDEO SETTINGS**

RF AGC SECAM		3
RF AGC NEIGHBOUR NO IMAGE NO		3
RF AGC NEIGHBOUR NO IMAGE YES		3
RF AGC NEIGHBOUR YES IMAGE NO		6
RF AGC NEIGHBOUR YES IMAGE YES		6
RF AGC TEST		3
ADC Calibration Source	<b>EXT-1</b>	
ADC Calibration R Gain		84
ADC Calibration G Gain		87
ADC Calibration B Gain		84
ADC Calibration R Offset		0
ADC Calibration G Offset		0
ADC Calibration B Offset		0

 Change Value       Back       Exit

## 1.2. Audio Settings

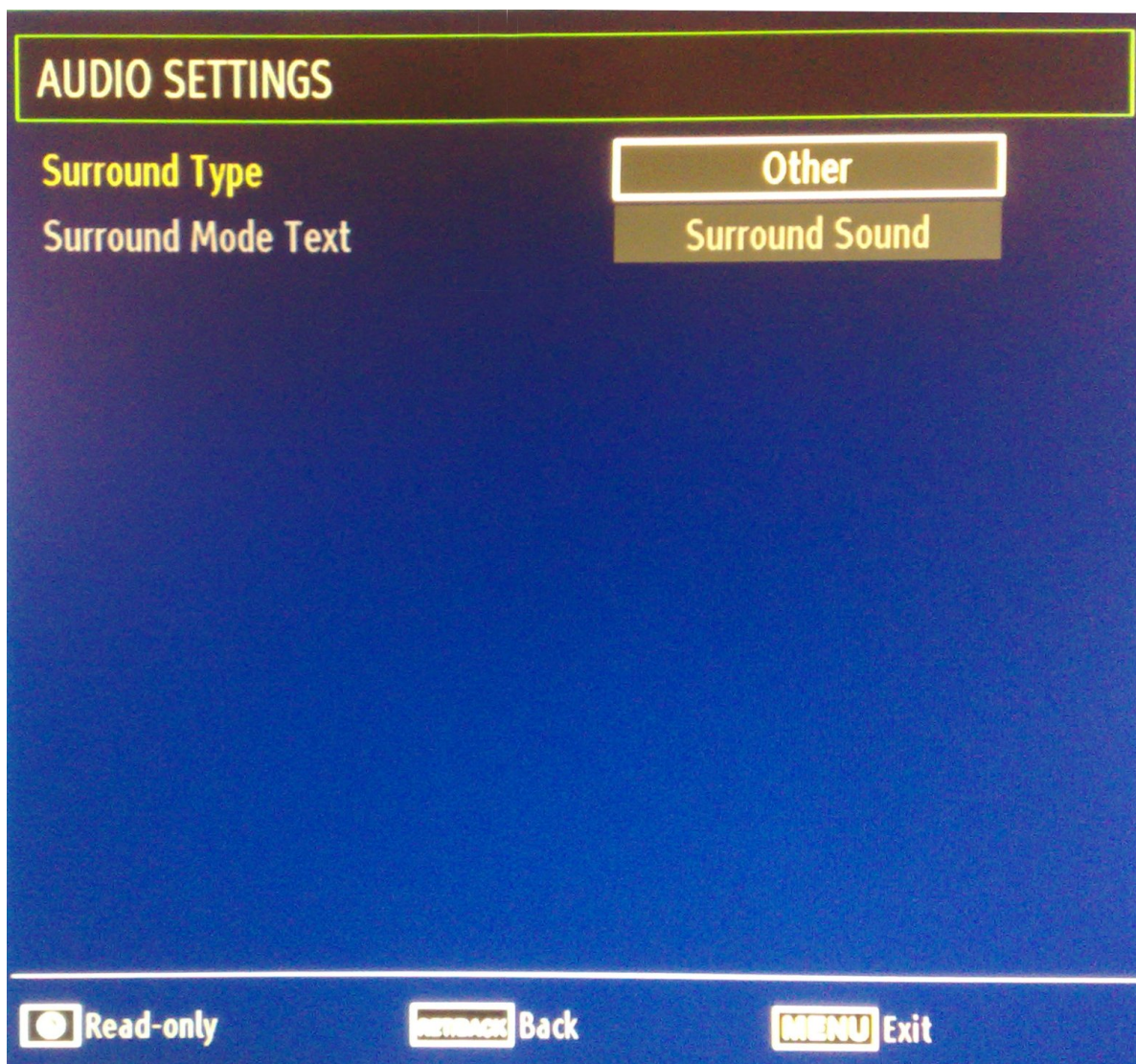



### 1.3. Options

#### Options-1

**OPTIONS 1**



<b>Auto TV OFF</b>	4 h
Power Up Mode	Last State
BacklightTrick Mode	Yes
Cable Support	No
EPG Type	2
Hotel Mode	Yes
LCN	No
PC Standby	Yes
Stby Search	Yes
Test Tool	Yes
Local Key	KeyPad
Volume Level	15

Read-only      Back      Exit

Options-2

**OPTIONS 2**

<b>Aps Sorting</b>	Enabled
Dynamic Menu	Disabled
EPG Menus	Enabled
Transparent Text	Enabled
HDMI Number	2
HDMI Auto Switch	Enabled
Rc Type	Rc3900
DCF ID	4851.dcf
Touchpad Sw Version	0

 Read-only       Back       Exit

## 1.4. Tuning Settings

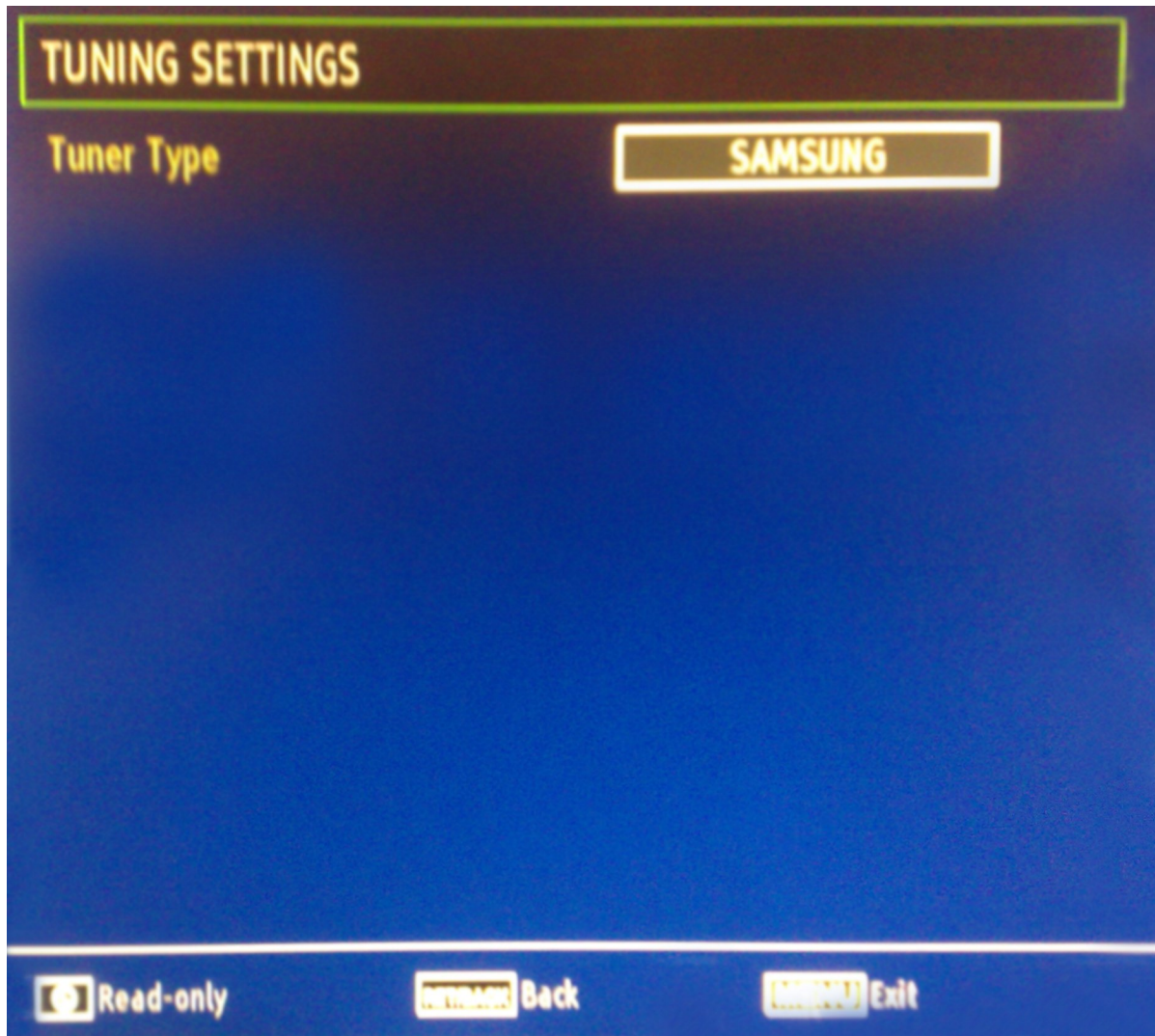

## 1.5. Source Settings

SOURCE SETTINGS	
SCART	Yes
SCART2	No
SCART2-S	No
SIDE AV	Yes
SCART-S	Yes
HDMI1	Yes
HDMI2	Yes
HDMI3	No
HDMI4	No
YPbPr	Yes
VGA/PC	Yes
BluRay	No



 Read-only       Back       Exit

Table2 Component signal format

No.	Resolution	H-frequecny (kHz)	V-frequecny (kHz)	Point clock pulse frequecny (MHz)	Note
1	72×480	15.734	60	13.5	480i (NTSC)
2	720×480	15.734	59.94	13.5	480i (NTSC)
3	720×576	15.625	50	13.5	576i (PAL)
4	720×480	31.469	60	27	480p (NTSC PROG)
5	720×480	31.469	59.94	27	480p (NTSC PROG)
6	720×576	31.25	50	27	576p (PAL PROG)
7	1280×720	45	59.94	74.18	720p (59p)
8	1280×720	45	60	74.25	720p (60p)
9	1280×720	37.5	50	74.25	720p (50p)
10	1920×1080	33.75	59.94	74.25	1080i (59i)
11	1920×1080	33.75	60	74.25	1080i (60i)
12	1920×1080	28.125	50	74.25	1080i (50i)
13	1920×1080	67.5	59.94	148.35	1080p (59p)
14	1920×1080	67.5	60	148.5	1080p (60p)
15	1920×1080	56.25	50	148.5	1080p (50p)
16	1920×1080	33.75	30	74.25	1080p (30p)
17	1920×1080	33.716	29.97	74.176	1080p (29.97p)
18	1920×1080	28.125	25	74.25	1080p (25p)
19	1920×1080	27	24	74.25	1080p (24p)
20	1920×1080	26.973	23.98	74.176	1080p (23.98p)

#### 5.4 D-SUB terminal

Input D-SUB signal (VG-848 signal generator), separately input the signals listed in table3 and check the display and sound. If the image is deflection of the Horizontal and vertical, select Picture->Screen->Auto Adjusting to perform auto-correct.

Table3 D-SUB signal format

No.	Resolution	H-frequecny (kHz)	V-frequecny (kHz)	Point clock pulse frequecny (MHz)	Note
1	640×480	31.469	59.94	25.175	IBM
2	720×400	31.469	70.086	28.322	IBM
3	640×480	37.861	72.809	31.5	VESA
4	640×480	37.5	75	31.5	VESA
5	800×600	35.156	56.25	36	VESA
6	800×600	37.879	60.317	40	VESA
7	800×600	48.077	72.188	50	VESA
8	800×600	46.875	75	49.5	VESA
9	1024×768	48.363	60.004	65	VESA
10	1024×768	56.476	70.069	75	VESA
11	1024×768	60.023	75.029	78.75	VESA
12	1152×864	67.5	75	108	VESA
13	1280×960	60	60	108	VESA
14	1280×1024	63.98	60.02	108	VESA
15	1280×1024	80	75	135	SXGA
16	1360×768	47.7	60	85.5	WXGA
17	1440×900	55.9	60	106.5	WXGA+
18	1400×1050	65.22	60	122.61	SXGA+
19	1680×1050	65.3	60	146.25	WSXGA+

### 5.5 HDMI terminal

Input HDMI signal (VG-849 signal generator), separately input the signals listed in table2 and table3

and check the display and sound (32KHz, 44.1KHz, 48KHz) at any situation (power on, channel

switch and format switch, etc.)

### 5.6 other functions check

a) Check the turn on/turn off timer, asleep timer, picture/sound mode, OSD, stereo and digital

sound port, etc.

b) Check the digital program, if Audio Only is normal.

c) Check logical channel number (LCN) for Australia.

d) Check OTA function for Australia special custom.

### 6. Presetting before ex-factory

Enter user menu LOCK page, select “Restore Factory Default” to preset the ex-factory.

a) Clear the program information

b) Clear VCHIP, parental control, etc.

c) Set the default data of user menu

8

d) Set Menu Language to English

e) Set Power on Mode to Off

## **SOFTWARE UPDATE**

In MB60 project there is only one software. From following steps software update procedure can be seen:

1. MB60\_en.bin, mboot.bin and usb\_auto\_update\_T4.txt documents should copy directly inside of a flash memory(not in a folder).
2. Put flash memory to the tv when tv is powered off.
3. Power on the and wait when the tv is opened.
4. If First Time Installtion screen comes, it means software update procedure is succesful.
  - **Checking Of The New Software**
  - 1. Turn off and on the TV.
  - 2. Enter the “Other Settings” submenu in the “Settings”.
  - 3. For controlling new software, check the “Software Upgrade” option.

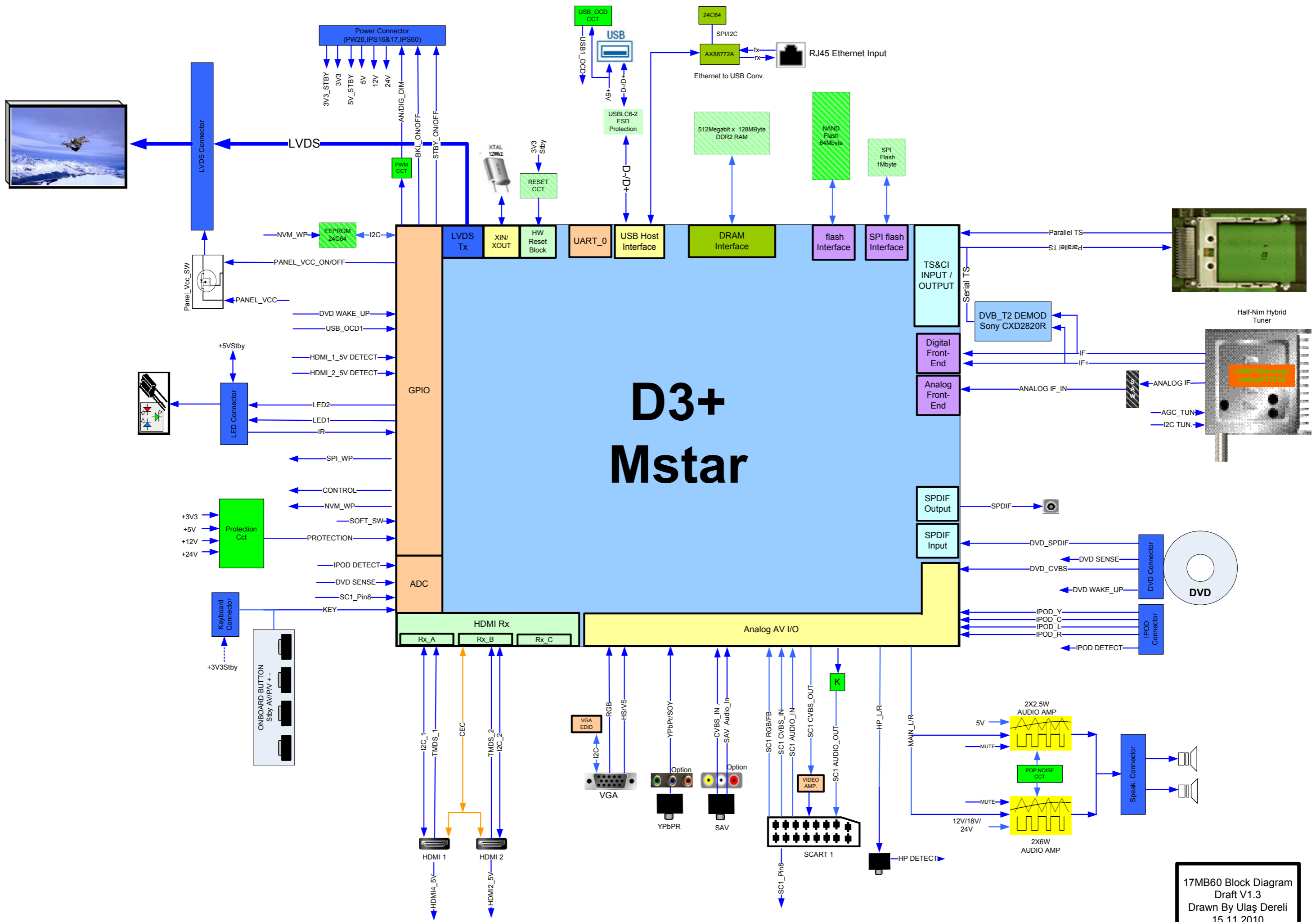

17MB60 Block Diagram  
 Draft V1.3  
 Drawn By Ulaş Dereli  
 15.11.2010



## 1.1. MSTAR Block Diagram

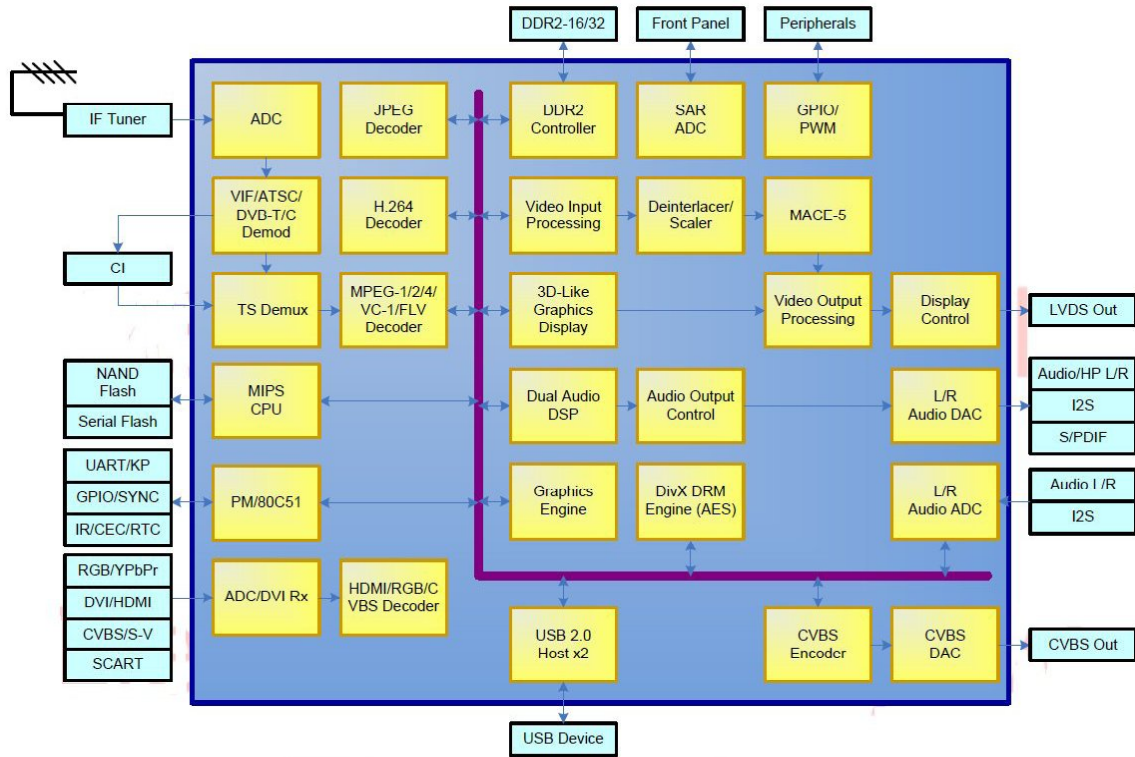

1.2. MB60 Placement of Blocks

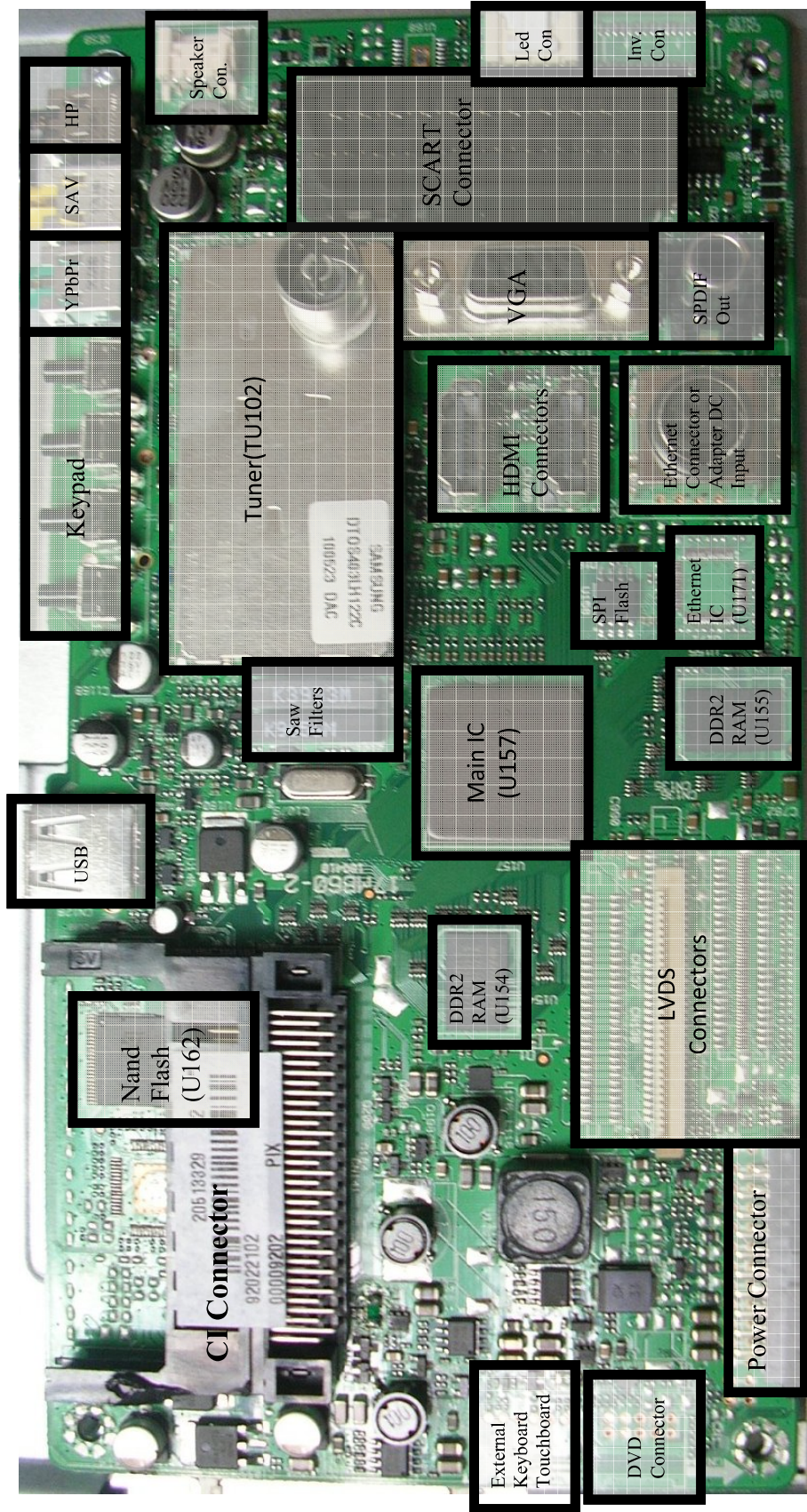

### 1.TUNER(TU102)

A horizontal mounted and Digital Half-Nim tuner is used in the product, which covers 3 Bands(From 48MHz to 862MHz for COFDM, from 45.25MHz to 863.25MHz for CCIR CH). The tuning is available through the digitally controlled I2C bus (PLL). Below you will find info about the tuner.

In active antenna option, the following circuit are used. ANT\_CTRL pin is controlled by microcontroller. If ANT\_CTRL is low, ANT\_PWR will be low. If ANT\_CTRL is high, ANT\_PWR will be high.

OVER\_CUR\_DETECT pin is a monitor for short circuit in antenna. OVER\_CUR\_DETECT is low, ANT\_CTRL will be low, so ANT\_PWR will be low. Finally, short circuit protection is done by circuits and microcontroller.

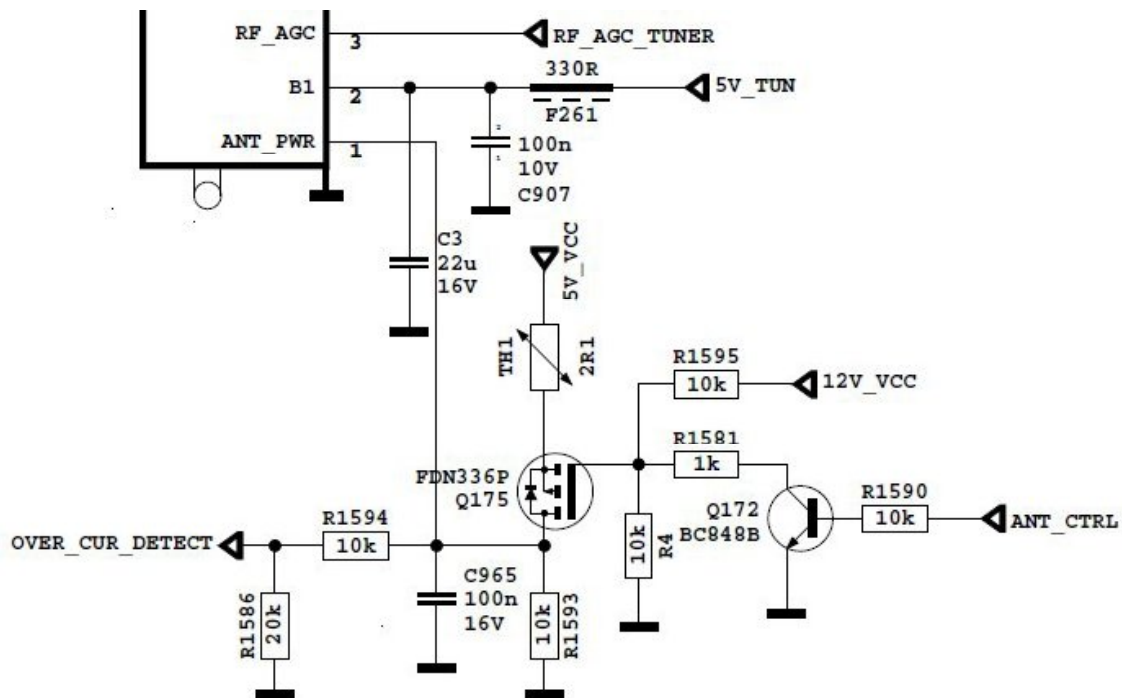

### 1.2. General description of Samsung DTOS403LH122X:

The Tuner covers 3 Bands(from 48MHz to 862MHz for COFDM, from 45.25MHz to 863.25MHz for CCIR CH). Band selection and Tuning are performed digitally via the I2C bus.

### 1.3. Features of DTOS403LH122X:

- Receiving System: This TUNER is designed to cover the air channels in VHF and UHF, compliant with DVB-T standard. and It covers all Analog channels from 48.25MHz to 863.25MHz
- Receiving Channel (Digital, Center frequency):

- VHF Low CH. E2 ~ S10 ( 50.5MHz ~ 170.5MHz )  
 VHF High CH. E5 ~ S41 ( 177.5MHz ~ 466 MHz )  
 UHF CH. E21 ~ E69 ( 474 MHz ~ 858 MHz )
- Receiving Channel (PAL, Picture carrier frequency):  
 VHF Low CH. E2 ~ S10 ( 48.25MHz ~ 168.25MHz )  
 VHF High CH. E5 ~ S41 ( 175.25MHz ~ 463.25MHz )  
 UHF CH. E21 ~ E70 ( 471.25MHz ~ 863.25MHz )
  - Intermediate Frequency:  
 Digital(center) DVB-T (36.167 MHz)  
 Digital(center) DVB-C (36.125 MHz)  
 Analog(picture) 38.9 MHz
  - Input Impedance: 75Ω, Unbalanced
  - Band Change-Over System  
 PLL Control System
  - Tuning System  
 Electronic Tuning System With PLL
  - Internal(or External) RF AGC function  
 Built in wideband AGC detector with 6 programmable take-over points

#### 1.4. Pinning:

Pin no.	Terminal Name	Pin Description
1	Ant Power	Active Antenna Power
2	B+	+5V, Supply Voltage (Preamplifier, DC/DC)
3	RF AGC	RF AGC (internal or external mode)
4	CL	I2C Serial Clock
5	DA	I2C Serial Clock
6	BP	+5V, Supply Voltage (RF Amp, PLL, IF Amp)
7	BT(T.P)	+33V, within DC/DC circuit
8	AS	I2C Address Selection of the PLL
9	IF AGC	Control voltage for the IF AGC
10	IF OUT +	Output 2 of the IF Amplifier
11	IF OUT -	Output 1 of the IF Amplifier
12	AIF Output	IF output of the Analog BroadBand

## 2. SAW FILTER – Audio – Epcos K9656M(Z101)

### 2.1. Standart

- B/G
- D/K
- I
- L/L'

## 2.2. Features

- TV IF audio filter with two channels
- Channel 1 (L') with one pass band for sound carriers at 40,40 MHz (L') and 39,75 MHz (L'- NICAM)
- Channel 2 (B/G,D/K,L,I) with one pass band for sound carriers between 32,35 MHz and 33,40 MHz

## 2.3. Pin configuration

- 1 Input
- 2 Switching input
- 3 Chip carrier - ground
- 4 Output
- 5 Output

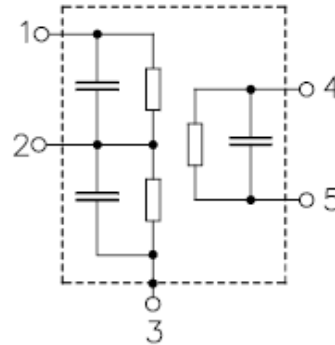

## 2.4. Frequency response

### Frequency response of channel 1

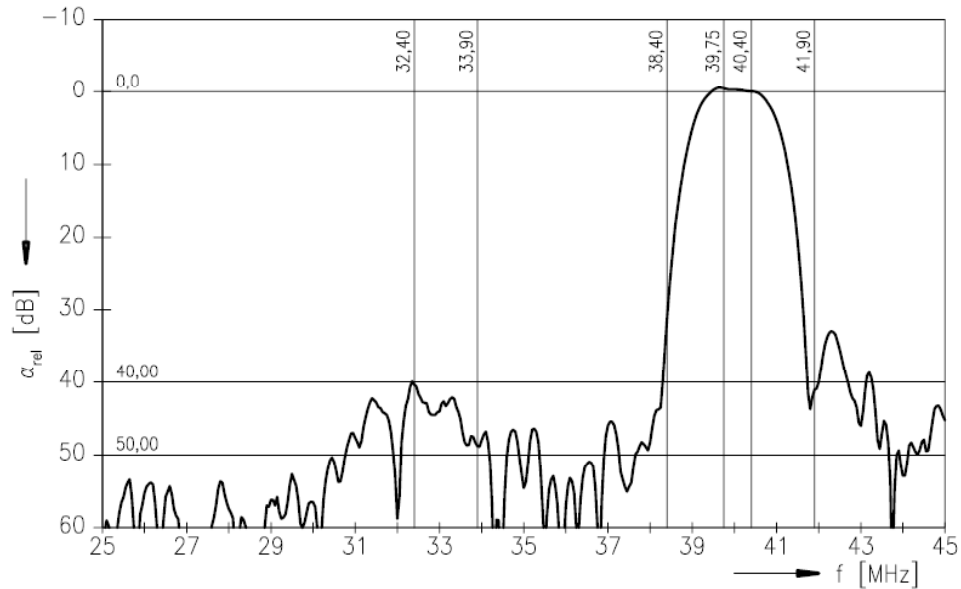

## Frequency response of channel 2

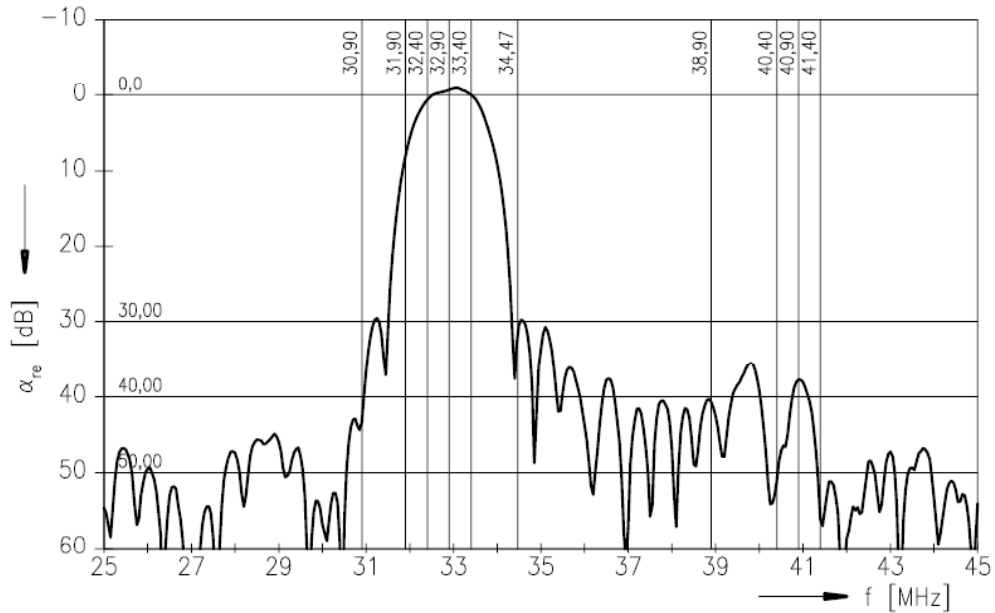

## 3. SAW FILTER – Video – Epcos K3958M(Z102)

### 3.1. Standart

- B/G
- D/K
- I
- L/L'

### 3.2. Features

- TV IF filter with Nyquist slopes at 33.90 MHz and 38.90 MHz
- Constant group delay

Pin configuration:

- 1 Input
- 2 Input - ground
- 3 Chip - carrier ground
- 4 Output
- 5 Output

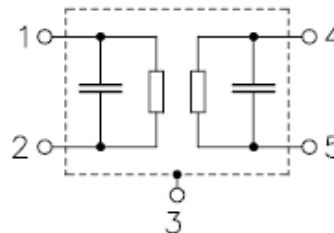

### 3.3. Frequency response

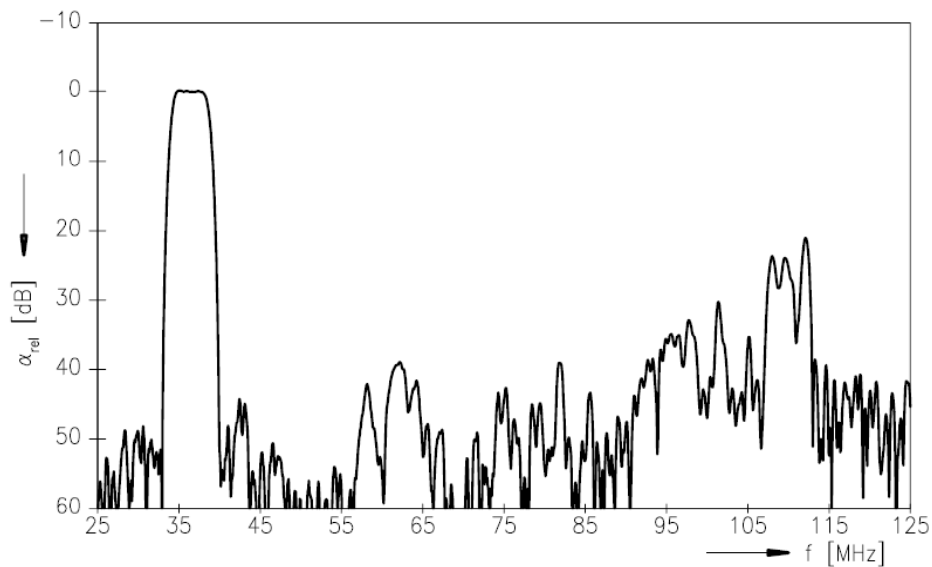
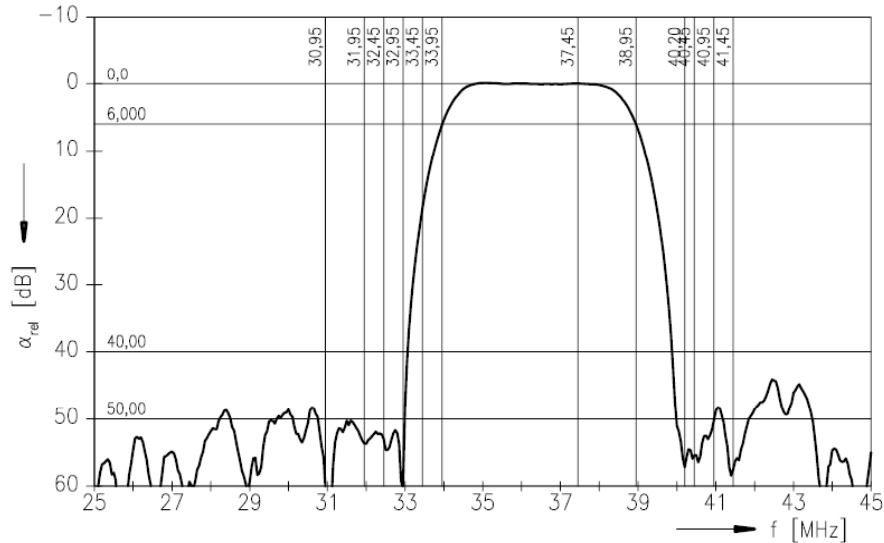

## 4. AUDIO AMPLIFIER STAGE WITH AZAD2102(U163, U164)

### 4.1. General Description

17MB60 uses two 2,5W Class D Mono Audio Amplifiers for from 16" to 24" TVs. AZAD2102B is a 2.9 Watts (max. can offer 3.0 Watts @ Load = 3 $\Omega$ , THD=10%, AVdd=DVdd=5.5Volt) with high efficiency filter-free class-D audio power amplifier in a 1613 mm x 1613 mm wafer chip scale package (WCSP). AZAD2102B uses Current-switch technology to achieve high performance class-d amplifier that features 0.03% THD, 85% efficiency, -70 dB PSRR, to improve RF-rectification immunity.

AZAD2102B provide a Vibration-Spectrum modulation clock for PWM Output. This vibration frequency is around 10KHZ shift (+/- 5KHZ of Fpwm).

The advantage of the small size package (WCSP) makes AZAD2102B very suitable for mobile phone and PDA device application. And the Class-D amplifier structure let AZAD2102B to have highly efficiency power consumption than Class-AB amplifier. AZAD2102B can shrink the application board, reduce system cost, and external components.

ESD level protection I/O embedded in AZAD2102B. For general applications, doesn't need to add extra ESD protection device (like Varistors) in application system for AZAD2102B's I/O.

#### **4.2. Features**

- CMOS Technology
- High Efficiency 85%
- High PSRR 70dB at 217Hz
- Differential OP-amp Input
- AZAD2102B provides Vibration-Spectrum Modulation clock for reduce EMI
- Provide Mute function(set Mute\_B to GND will go into Mute status)
- For the input stage AZAD2102B built-in a 10Kohm resistors (Gain setting=29.5dB)
- Maximum Battery Life and Minimum Heat
- Efficiency With an 8-Ω Speaker:
- 3.5 mA Quiescent Current
- Output Power at 10% THD
- 2.85Watts at AVdd=DVdd=5.0Volt, Rload=4Ω
- 1.45Watts at AVdd=DVdd=3.6Volt, Rload=4Ω
- 0.30Watts at AVdd=DVdd=3.0Volt, Rload=4Ω
- 1.75Watts at AVdd=DVdd=5.5Volt, Rload=8Ω
- 0.87Watts at AVdd=DVdd=3.6Volt, Rload=8Ω
- 0.41Watts at AVdd=DVdd=3.0Volt, Rload=8Ω
- Eliminate Power on and Power-off "Pop" noise
- A Fewer External Components
- Optimized PWM Output Stage Eliminates LC Output Filter
- Internally generate 290 kHz Switching Frequency to eliminate Capacitor and Resistor
- Improve PSRR (-70 dB) and Wide Supply Voltage (3.0 V to 5.5 V)
- Fully Differential Design Reduces RF Rectification
- This chip has been built-in a very strong ESD protection.
- System level ESD 4KV (IEC 61000-4-2 ESD Contact Level)
- Wafer Chip Scale Package (WCSP)
- TSSOP Package with Exposed Pad



## 4.3. Absolute Ratings

### 4.3.1. Electrical Characteristics

VDD=AVdd=DVdd , VSS=AVss=DVss=Ground

TA = 25°C, Filter Bandwidth = 20 ~20KHz

PARAMETER	Symbol	TEST CONDITIONS	MIN	TYP	MAX	UNIT
Operating Voltage	Vop	AVdd=DVdd to AVss=DVss	3.0	5	5.5	V
Output offset voltage	VOS	VDD = 5.5 V, VI = 0 V, AV = 6 V/V		4.5	6.5	mV
		VDD = 3.6 V, VI = 0 V, AV = 6 V/V		2.1	4.0	
		VDD = 3.0 V, VI = 0 V, AV = 6 V/V		1.2	3.0	
Power supply rejection ratio	PSRR	VDD = 3.0 V to 5.5 V, AV = 2 V/V input ac grounded with Ci=2.2uF,Vripple=200mVpp, RL=8Ω,f=217Hz		-68		dB
Common mode rejection ratio	CMRR	VDD = 3.0 V to 5.5 V , Vi c = VDD/2 to 0.5 V, Vi c = VDD/2 to 0.5 VDD -0.8 V,		-65		dB
High level Input current	IiHl	VDD= 5.5V, Vi=5.8V		25		uA
Low level Input current	IiLl	VDD= 5.5V, Vi=-0.3V		1		uA
Operation current	Iop	VDD = 5.5 V, no load		3.6	5.0	mA
		VDD = 3.6 V, no load		3.0	4.2	
		VDD = 3.0 V, no load		2.5	3.5	
Output switching frequency	Fpwm	VDD = 5.5 V, no load		290		KHz
		VDD = 3.6 V, no load		300		
		VDD = 3.0 V, no load		315		
Vibration-Spectrum Modulation clock Range	Fvs	VDD = 5.0 V, no load		+/-5	+/-10	KHz
Under Voltage Protection	UVP	Vin+ and Vin- connect to GND, no load		2.0	2.5	V
Mute_B pin Impedance	RMuB	Mute_B to Ground		270		KΩ
Gain	Gain	VDD=5.0V,Ri=5KΩ+10KΩ (Av=20V/V)	18	20	22	V/V

### 4.3.2. Operating Specifications

TA = 25°C, Gain = 20 V/V,

PARAMETER		TEST CONDITIONS		MIN	TYP	MAX	UNIT
Pw	Output power	THD + N = 10%, f = 1 kHz, RL = 4 Ω	VDD = 5.0 V	2.85			W
			VDD = 3.6 V	1.45			
			VDD = 3.0 V	0.77			
		THD + N = 1%, f = 1 kHz, RL = 4 Ω	VDD = 5.0 V	2.25			W
			VDD = 3.6 V	1.15			
			VDD = 3.0 V	0.60			
		THD + N = 10%, f = 1 kHz, RL = 8 Ω	VDD = 5.0 V	1.75			W
			VDD = 3.6 V	0.87			
			VDD = 3.0 V	0.47			
		THD + N = 1%, f = 1 kHz, RL = 8 Ω	VDD = 5.0 V	1.39			W
			VDD = 3.6 V	0.70			
			VDD = 3.0 V	0.36			
THD+N	Total harmonic distortion plus noise	VDD = 5.0 V, PO = 1 W, RL = 8 Ω, f = 1 kHz		0.15			%
		VDD = 3.6 V, PO = 0.5 W, RL = 8 Ω, f = 1 kHz		0.12			
		VDD = 3.0 V, PO = 200 mW, RL = 8 Ω, f = 1 kHz		0.09			
PSRR	Supply ripple rejection ratio	VDD = 3.6 V, Av=20V/V, Inputs connect to grounded with Ci = 1.0μF	F = 217 Hz, VRipple = 200 mVpp	-67			dB
SNR	Signal-to-noise ratio	VDD = 5 V, PO = 1 W, RL = 8 Ω		95			dB
Vnoise	Output noise level	VDD = 3.6 V, f = 20 Hz to 20 kHz, Inputs ac-grounded with Ci = 1.0μF		No weighting	45		μVRMS
				A weighting	40		
CMRR	Common mode rejection ratio	VDD = 3.6 V, Vin = 100mVpp		f = 217 Hz	-72		dB
ZI	Input impedance			8	10	12	kΩ
ZF	Feedback resistor			120	150	180	kΩ

#### 4.4. Pinning

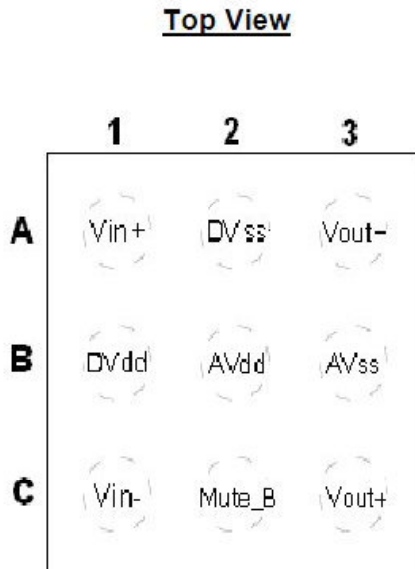

Pad Location	Pad Name	I/O	Function
A1	Vin+	I	Non-inverting Input
B1	DVdd		Supply Voltage for control circuit
C1	Vin-	I	Inverting Input
A2	DVss		Ground pad for control circuit
B2	AVdd		Supply Voltage for Power MOS
C2	Mute_B	I	Mute control pin
A3	Vout-	O	Negative Output
B3	AVss		Ground pad for Power MOS
C3	Vout+	O	Positive Output

## 5. AUDIO AMPLIFIER STAGE WITH TPA3113(U168)

### 5.1. General Description

17MB60 uses a 6W Class D Mono Audio Amplifiers for from 26" to 32" TVs. The TPA3113D2 is a 6-W (per channel) efficient, Class-D audio power amplifier for driving bridged-tied stereo speakers. Advanced EMI Suppression Technology enables the use of inexpensive ferrite bead filters at the outputs while meeting EMC requirements. SpeakerGuard™ speaker protection circuitry includes an adjustable power limiter and a DC detection circuit. The adjustable power limiter allows the user to set a "virtual" voltage rail lower than the chip supply to limit the amount of current through the speaker. The DC detect circuit measures the frequency and amplitude of the PWM signal and shuts off the output stage if the input capacitors are damaged or shorts exist on the inputs.

The TPA3113D2 can drive stereo speakers as low as 4 Ω. The high efficiency of the TPA3113D2, 87%, eliminates the need for an external heat sink when playing music.

The outputs are also fully protected against shorts to GND, VCC, and output-to-output. The short-circuit protection and thermal protection includes an auto-recovery feature.

## 5.2. Features

- 6-W/ch into an 8-Ω Loads at 10% THD+N From a 10-V Supply
- 12-W into a 4-Ω Mono Load at 10% THD+N From a 10-V Supply
- 87% Efficient Class-D Operation Eliminates Need for Heat Sinks
- Wide Supply Voltage Range Allows Operation from 8 V to 26 V
- Filter-Free Operation
- SpeakerGuard™ Speaker Protection Includes Adjustable Power Limiter plus DC Protection
- Flow Through Pin Out Facilitates Easy Board Layout
- Robust Pin-to-Pin Short Circuit Protection and Thermal Protection with Auto Recovery Option
- Excellent THD+N / Pop-Free Performance
- Four Selectable, Fixed Gain Settings
- Differential inputs

## 5.3. Absolute Ratings

### 5.3.1. Electrical Characteristics

#### DC CHARACTERISTICS

$T_A = 25^\circ\text{C}$ ,  $V_{CC} = 12\text{ V}$ ,  $R_L = 8\ \Omega$  (unless otherwise noted)

PARAMETER		TEST CONDITIONS	MIN	TYP	MAX	UNIT	
$ V_{OS} $	Class-D output offset voltage (measured differentially)	$V_I = 0\text{ V}$ , Gain = 36 dB		1.5	15	mV	
$I_{CC}$	Quiescent supply current	$\overline{SD} = 2\text{ V}$ , no load, $PV_{CC} = 12\text{V}$		20	35	mA	
$I_{CC(SD)}$	Quiescent supply current in shutdown mode	$\overline{SD} = 0.8\text{ V}$ , no load, $PV_{CC} = 12\text{V}$		200		$\mu\text{A}$	
$r_{DS(on)}$	Drain-source on-state resistance	$V_{CC} = 12\text{ V}$ , $I_O = 500\text{ mA}$ , $T_J = 25^\circ\text{C}$	High Side	400		m $\Omega$	
			Low side	400			
G	Gain	GAIN1 = 0.8 V	GAIN0 = 0.8 V	19	20	21	dB
			GAIN0 = 2 V	25	26	27	
		GAIN1 = 2 V	GAIN0 = 0.8 V	31	32	33	dB
			GAIN0 = 2 V	35	36	37	
$t_{ON}$	Turn-on time	$\overline{SD} = 2\text{ V}$		14		ms	
$t_{OFF}$	Turn-off time	$\overline{SD} = 0.8\text{ V}$		2		$\mu\text{s}$	
GVDD	Gate Drive Supply	$I_{GVDD} = 2\text{ mA}$	6.4	6.9	7.4	V	
$V_O$	Output Voltage maximum under PLIMIT control	$V_{(PLIMIT)} = 2\text{ V}$ ; $V_I = 1\text{ V rms}$	6.75	7.90	8.75	V	

## 5.3.2. Operating Specifications

### AC CHARACTERISTICS

$T_A = 25^\circ\text{C}$ ,  $V_{CC} = 12\text{ V}$ ,  $R_L = 8\ \Omega$  (unless otherwise noted)

PARAMETER		TEST CONDITIONS	MIN	TYP	MAX	UNIT
$K_{SVR}$	Supply ripple rejection	200 mV <sub>PP</sub> ripple from 20 Hz–1 kHz, Gain = 20 dB, Inputs ac-coupled to AGND		-70		dB
THD+N	Total harmonic distortion + noise	$R_L = 8\ \Omega$ , $f = 1\text{ kHz}$ , $P_O = 3\text{ W}$ (half-power)		0.06		%
$V_n$	Output integrated noise	20 Hz to 22 kHz, A-weighted filter, Gain = 20 dB		65		$\mu\text{V}$
				-80		dBV
	Crosstalk	$P_O = 1\text{ W}$ , Gain = 20 dB, $f = 1\text{ kHz}$		-100		dB
SNR	Signal-to-noise ratio	Maximum output at THD+N < 1%, $f = 1\text{ kHz}$ , Gain = 20 dB, A-weighted		102		dB
$f_{OSC}$	Oscillator frequency		250	310	350	kHz
	Thermal trip point			150		$^\circ\text{C}$
	Thermal hysteresis			15		$^\circ\text{C}$

## 5.4. Pinning

PIN		I/O/P	DESCRIPTION
NAME	Pin Number		
$\overline{SD}$	1	I	Shutdown logic input for audio amp (LOW = outputs Hi-Z, HIGH = outputs enabled). TTL logic levels with compliance to AVCC.
$\overline{FAULT}$	2	O	Open drain output used to display short circuit or dc detect fault status. Voltage compliant to AVCC. Short circuit faults can be set to auto-recovery by connecting $\overline{FAULT}$ pin to $\overline{SD}$ pin. Otherwise, both short circuit faults and dc detect faults must be reset by cycling PVCC.
LINP	3	I	Positive audio input for left channel. Biased at 3V.
LINN	4	I	Negative audio input for left channel. Biased at 3V.
GAIN0	5	I	Gain select least significant bit. TTL logic levels with compliance to AVCC.
GAIN1	6	I	Gain select most significant bit. TTL logic levels with compliance to AVCC.
AVCC	7	P	Analog supply
AGND	8		Analog signal ground. Connect to the thermal pad.
GVDD	9	O	High-side FET gate drive supply. Nominal voltage is 7V. Also should be used as supply for PLIMIT function
PLIMIT	10	I	Power limit level adjust. Connect a resistor divider from GVDD to GND to set power limit. Connect directly to GVDD for no power limit.
RINN	11	I	Negative audio input for right channel. Biased at 3V.
RINP	12	I	Positive audio input for right channel. Biased at 3V.
NC	13		Not connected
PBTL	14	I	Parallel BTL mode switch
PVCCR	15	P	Power supply for right channel H-bridge. Right channel and left channel power supply inputs are connect internally.
PVCCR	16	P	Power supply for right channel H-bridge. Right channel and left channel power supply inputs are connect internally.
BSPR	17	I	Bootstrap I/O for right channel, positive high-side FET.
OUTPR	18	O	Class-D H-bridge positive output for right channel.
PGND	19		Power ground for the H-bridges.
OUTNR	20	O	Class-D H-bridge negative output for right channel.
BSNR	21	I	Bootstrap I/O for right channel, negative high-side FET.
BSNL	22	I	Bootstrap I/O for left channel, negative high-side FET.
OUTNL	23	O	Class-D H-bridge negative output for left channel.
PGND	24		Power ground for the H-bridges.
OUTPL	25	O	Class-D H-bridge positive output for left channel.
BSPL	26	I	Bootstrap I/O for left channel, positive high-side FET.
PVCLL	27	P	Power supply for left channel H-bridge. Right channel and left channel power supply inputs are connect internally.
PVCLL	28	P	Power supply for left channel H-bridge. Right channel and left channel power supply inputs are connect internally.

## 6. POWER STAGE

The DC voltages required at various parts of the chassis and panel are provided by a main power supply unit. MB60 chassis can operate with IPS60, IPS16, IPS17, PW26, PW27 as main power supply and also with 12V adaptor.

CN706 is used for IPS60, IPS16 and IPS17 and CN1 is used for PW26 and PW27.

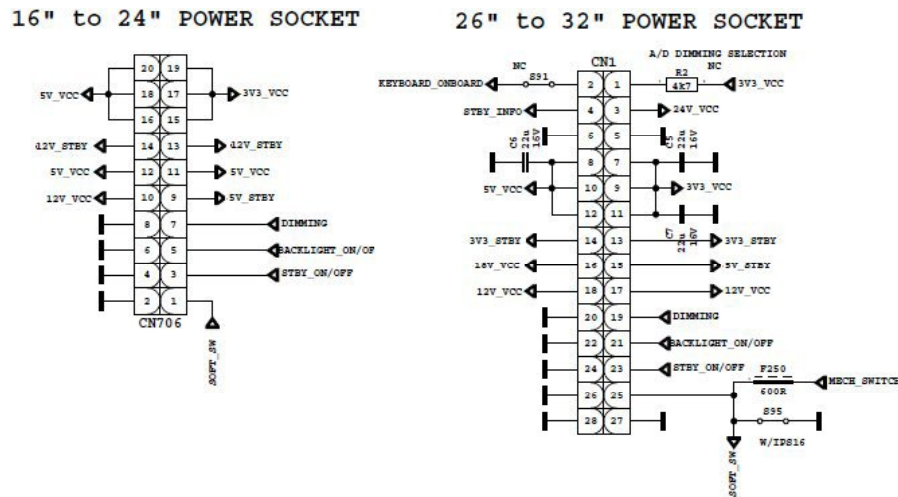

JK9 is used for the adapter option and also CN705 inverter socket or DB32 chassis with CN706 is used to supply backlight.

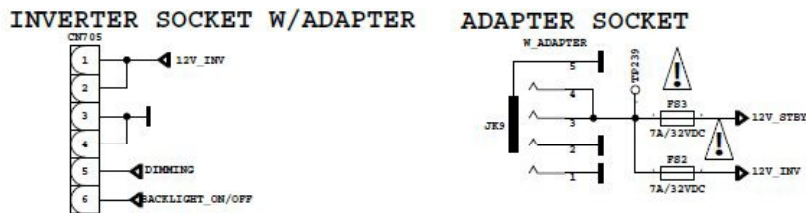

The power supplies generate 18V, 12V, 5V, 3,3V and 12V, 5V, stand by mode DC voltages. Power stage which is on-chassis generates 5V, 3V3 stand by voltage and 12V, 8V, 5V, 3V3, 2.5V, 1,8V and 1,2V supplies for other different parts of the chassis. Chassis block diagram is indicated below.

## POWER BLOCK DIAGRAM

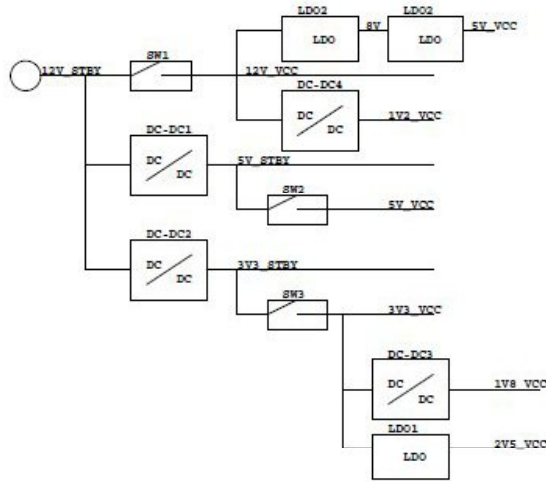

The blocks on power block diagram is using dependent to main supply. For PW26 and PW27 just common blocks are enough for proper operation.

## COMMON

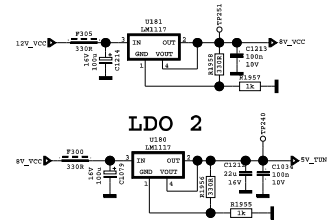
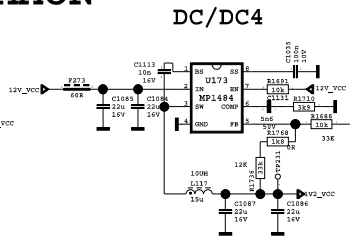
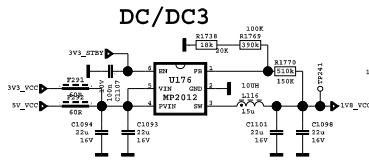
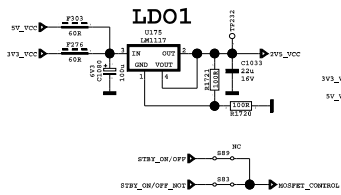

For IPS16, IPS17, IPS60 below blocks must work properly.

## W/ADAPTOR & W/IPS16&17&60

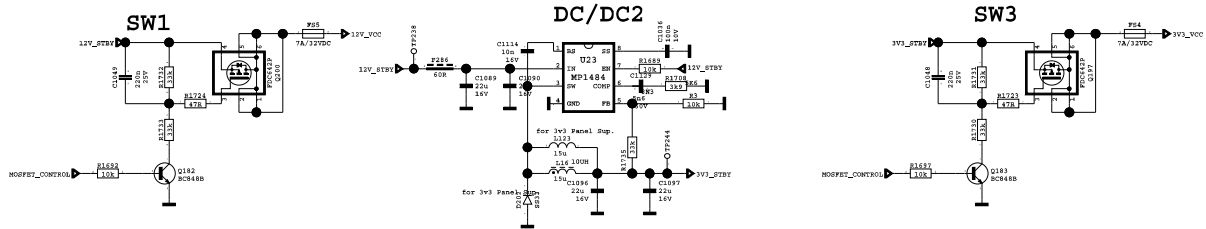

For adopter case also below blocks are necessary.

### ADAPTER SOCKET

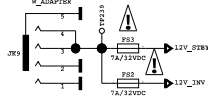

### INVERTER SOCKET W/ADAPTER

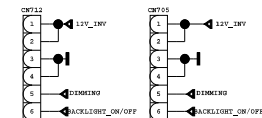

15. 6" LED SOCKET      OCFL INVERTER SOCKET

## W/ADAPTOR

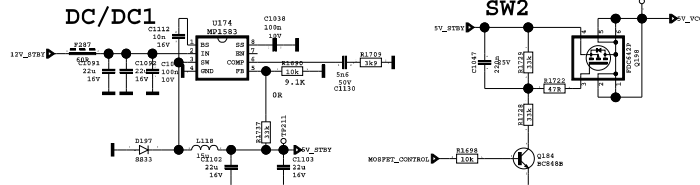

### SW2

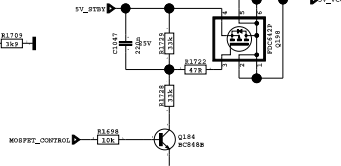

### POWER BLOCK DIAGRAM

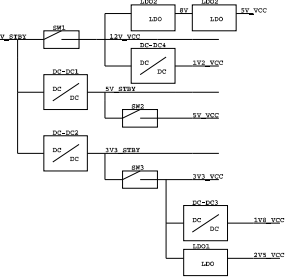

## Short CCT Protection Circuit

Short circuit protection is necessary for protecting chassis and main IC against damages when any Vcc supply shorts to ground. Protect pin should be logic high while normal operation. When there is a short circuit protect pin should be logic low. After any short detection, SW forces LEDs on LED card to blink.

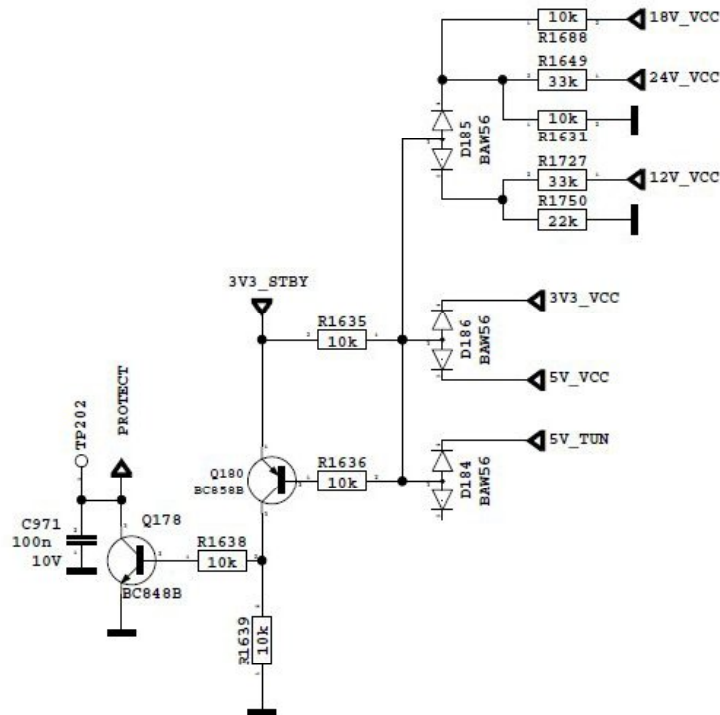



# 6.1 Power Management -- W/Adapter

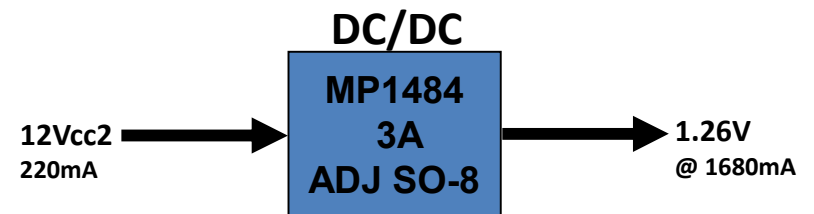
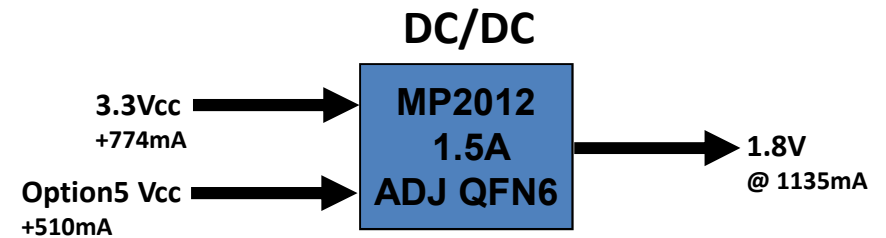
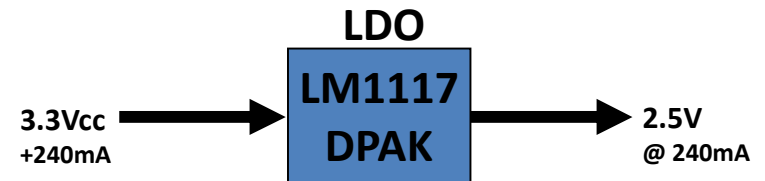
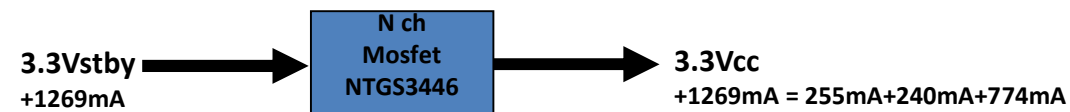
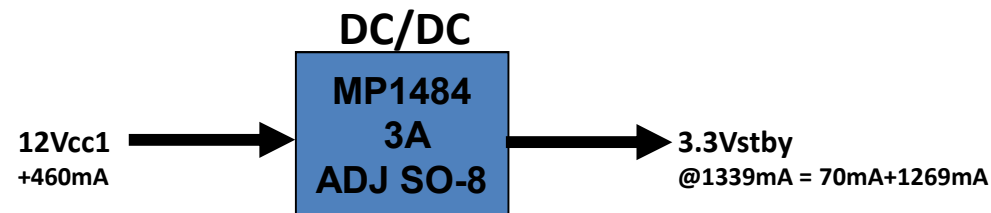
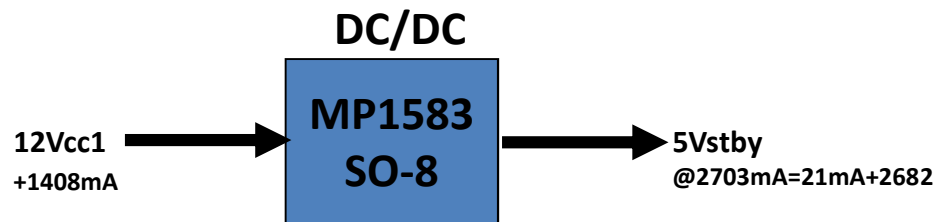
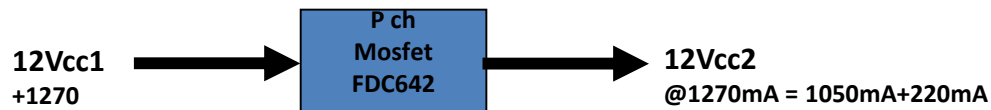
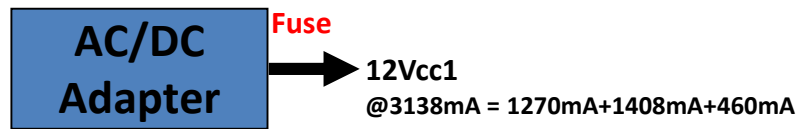

# MB60 Power Management W/PW26

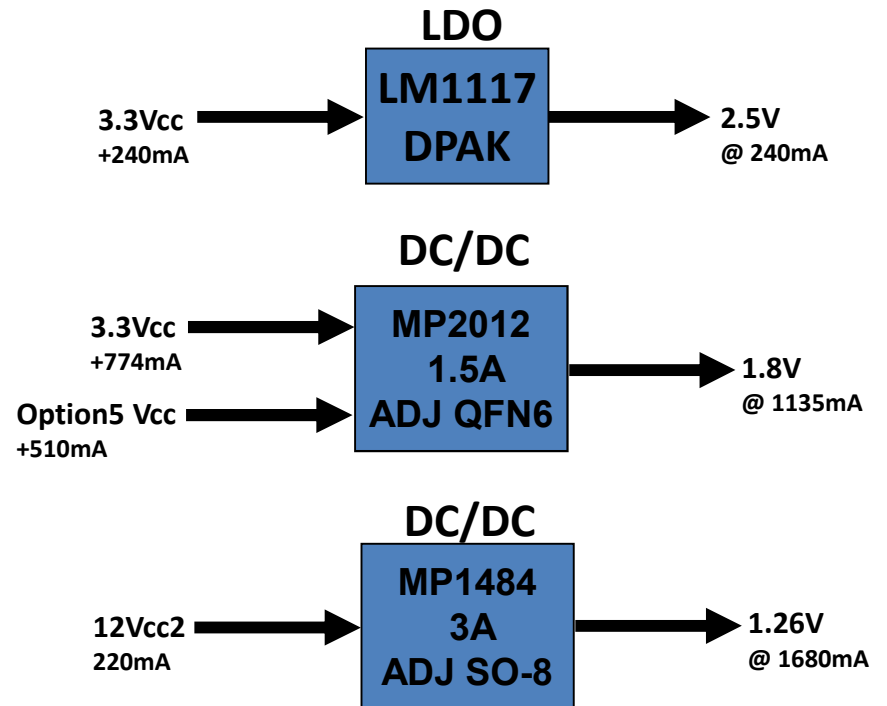
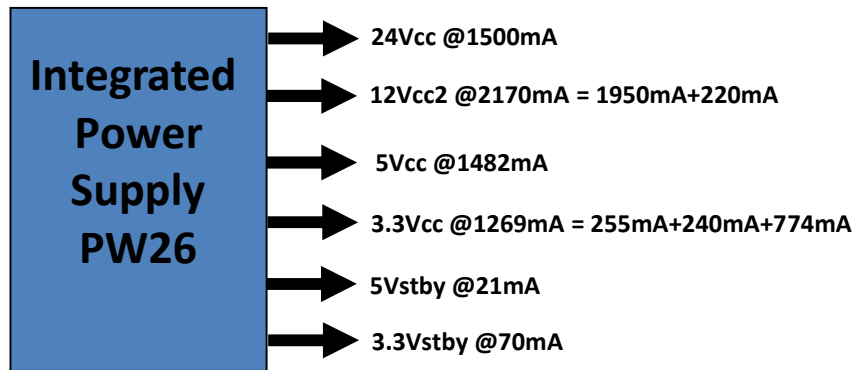

# MB60 Power Management W/PW27 & PW03 & PW04

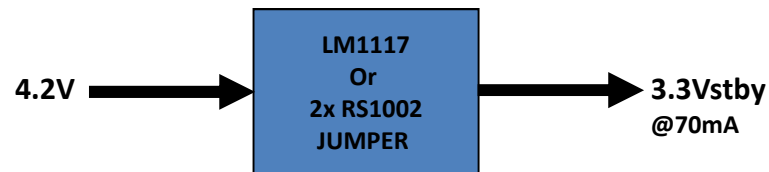
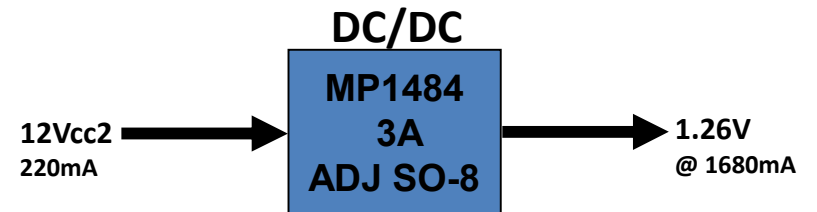
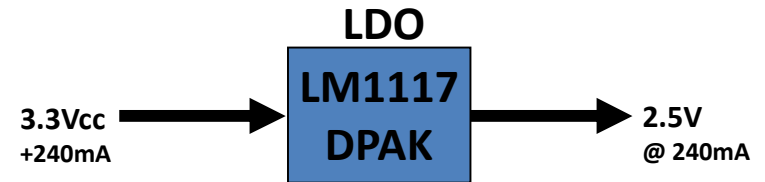
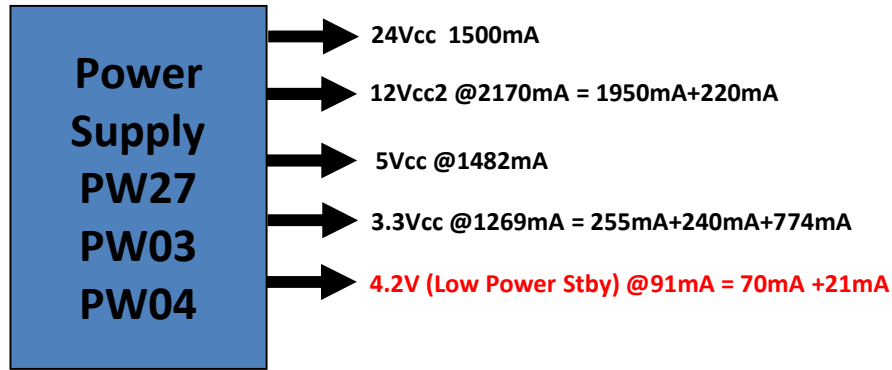

# MB60 Power Management W/IPS16 & IPS17 & IPS60

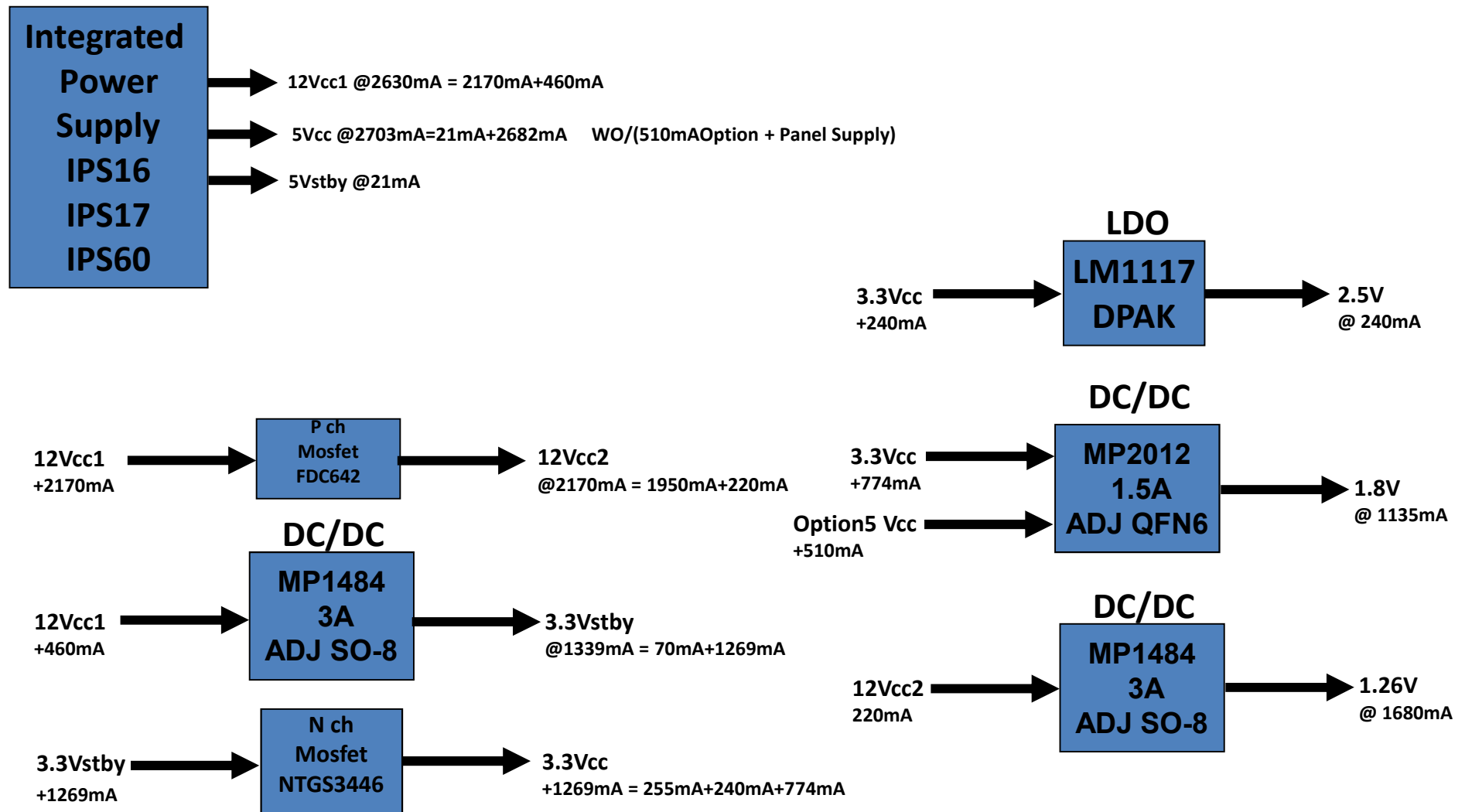

## 7. MICROCONTROLLER – MSTAR(U157)

### 7.1. General Description

The MSD9WB7PX-2 integrates DTV/multi-media all-purpose AV decoder, DVB-T demodulator, VIF demodulator, and Sound/Video processor into a single device. This allows the overall BOM to be reduced significantly making the MSD9WB7PX-2 a very competitive multi-media DTV solution. For ATV users, the MSD9WB7PX-2 provides multi-standard analog TV support with adaptive 3D video decoding and VBI data extraction. The build-in audio decoder is capable of decoding FM, AM, NICAM, A2, BTSC and EIA-J sound standards. The MSD9WB7PX-2 supplies all the necessary A/V inputs and outputs to complete a receiver design including a multi-port HDMI receiver and component video ADC. All input selection multiplexed for video and audio are integrated, including full SCART support with CVBS output. The equipped MStar MACE-5 color engine is the latest masterpiece from MStar famous color engine series providing excellent video and picture quality in Full-HD and large-scale displaying system. To meet the increasingly popular energy legislative requirements without the use of additional hardware, the MSD9WB7PX-2 has an ultra low power standby mode during which an embedded MCU can act upon standby events and wake up the system as required.

### 7.2. General Features

MSD9WB9PX-2, an SOC solution that supports channel decoding, MPEG decoding, and media-centre functionality enabled by a high performance AV CODEC and CPU Key features include,

- Digital and Analog DVB Front-End Demodulator
- A Multi-Standard A/V Format Decoder
- The MACE-5 Video Processor
- Home Theater Sound Processor
- Peripheral and Power Management

#### Transport Stream De-multiplexer

- Supports parallel and serial TS interface, with or without sync signal
- Supports TS input and output for external CI module
- Maximum TS data rate is 104 Mb/sec for serial or 16 MB/sec for parallel
- 32 general purpose PID filters and section filters for each transport stream de-multiplexer
- Supports additional audio/video/PCR filters
- Supports TS DMA channel for time-shift
- Supports 3DES/DES and AES encryption/decryption

#### MPEG-2 Video Decoder

- ISO/IEC 13818-2 MPEG-2 video MP@HL
- Automatic frame rate conversion
- Supports resolution up to HDTV (1080i, 720p) and SDTV

#### MPEG-4 Video Decoder

- ISO/IEC 14496-2 MPEG-4 ASP video decoding
- Supports resolutions up to HDTV (1080p@30fps)
- Supports DivX1 Home Theater & HD profiles Optional
- Supports VC-1 Optional, FLV video format decoding

#### H.264 Decoder

- ITU-T H.264, ISO/IEC 14496-10 (main and high profile up to level 4.1) video decoding

- Supports resolutions for all DVB, ATSC, HDTV, DVD and VCD
- Supports resolution up to 1080p@30fps
- Supports CABAC and CAVLC stream types
- Processing of ES and PES streams, extraction and provision of time stamps
- Up to 40 Mbits bitrate (Blu-ray spec.)

#### **Hardware JPEG**

- Supports sequential mode, single scan
- Supports both color and grayscale pictures
- Following the file header scan the hardware decoder fully handles the decode process
- Supports programmable Region of Interest (ROI)
- Supports formats: 422/411/420/444/422T
- Supports scaling down ratios: 1/2, 1/4, 1/8
- Supports picture rotation

#### **NTSC/PAL/SECAM Video Decoder**

- Supports NTSC-M, NTSC-J, NTSC-4.43, PAL (B, D, G, H, M, N, I, Nc), and SECAM standards
- Automatic standard detection
- Motion adaptive 3D comb filter
- Five configurable CVBS & Y/C S-video inputs
- Supports Teletext, Closed Caption (analog CC 608/ analog CC 708/digital CC 608/digital CC 708), V-chip and SCTE

#### **Multi-Standard TV Sound Processor**

- SIF audio decoding
- Supports BTSC/A2/EIA-J demodulation
- Supports NICAM/FM/AM demodulation
- Supports MTS Mode Mono/Stereo/SAP in BTSC/EIA-J mode
- Supports Mono/Stereo/Dual in A2/NICAM mode
- Built-in audio sampling rate conversion (SRC)
- Audio processing for loudspeaker channel, including volume, balance, mute, tone, EQ, virtual stereo/surround and treble/bass controls
- Advanced sound processing options available, for example: Dolby, SRS, BBE, QSound, Audyssey
- Supports digital audio format decoding:
- MPEG-1, MPEG-2 (Layer I/II), MP3, Dolby Digital (AC-3), AAC-LC
- Supports Optional Dolby Digital Plus, Dolby Pulse, and MS10 multistream decoder, including Dolby Digital Encoder for transcoding streams to Dolby Digital 5.1 (DDCO)
- Supports MPEG Audio, Dolby Digital, Dolby Digital Plus format AD (Audio Description)
- Supports PVR and time-shifting

#### **Audio Interface**

One SIF audio input interface with minimal external saw filters

- Four L/R audio line-inputs including Mic. input
- Two L/R outputs for main speakers and additional line-outputs
- Supports stereo headphone driver
- I2S digital audio input & output
- S/PDIF digital audio output
- HDMI audio channel processing
- Programmable delay for audio/video synchronization

#### **Analog RGB Compliant Input Port**

- Three analog ports support up to 1080P
- Supports PC RGB input up to SXGA@75Hz
- Supports HDTV RGB/YPbPr/YCbCr
- Supports Composite Sync and SOG Sync-on-Green
- Automatic color calibration
- AV-link support

#### **Analogue RGB Auto-Configuration & Detection**

- Auto input signal format and mode detection
- Auto-tuning function including phasing, positioning, offset, gain, and jitter detection
- Sync Detection for H/V Sync

#### **DVI/HDCP/HDMI Compliant Input Port**

- Three HDMI/DVI Input ports
- HDMI 1.3 Compliant
- HDCP 1.1 Compliant
- 225MHz @ 1080P 60Hz input with 12-bit Deep-color support
- CEC support
- Single link DVI 1.0 compliant
- Robust receiver with excellent long-cable support

#### **MStar Advanced Color Engine (MStarACE-5)**

- 10/12-bit internal data processing
- Fully programmable multi-function scaling engine
- Nonlinear video scaling supports various modes including Panorama
- Supports dynamic scaling for VC-1
- High-Quality DTV video processor
- 3D motion video deinterlacer with motion object stabilizer
- Edge-oriented deinterlacer with edge and artifact smoother
- Automatic 3:2/2:2/M:N pull-down detection and recovery
- 3D multi-purpose noise reduction for DTV or lousy air/cable input
- MPEG artifact removal including de-blocking and mosquito noise reduction
- Arbitrary frame rate conversion
- MStar Professional Picture Enhancement:
  - Dynamic brilliant and fresh color
  - Dynamic *Blue Stretch*
  - Intensified contrast and details
  - Dynamic *Vivid Skin*

- Dynamic sharpened Luma/Chroma edges
- Global and local dynamic depth of field perception
- Accurate and independent color control
- Supports sRGB and xvYCC color processing
- Supports HDMI 1.3 deep color format
- Programmable 12-bit RGB gamma CLUT

### **Output Interface**

- Single/dual link 8/10-bit LVDS output
- Supports panel resolution up to Full-HD (1920x1080) @ 60Hz
- Supports TH/TI format
- Supports dithering options to 6/8-bit output
- Spread spectrum output for EMI suppression

### **CVBS Video Encoder**

- Supports all NTSC/PAL TV Standard
- Stand-alone scaling engine
- Programmable Hue, Contrast, Brightness
- Supports TTX/CC/WSS output

### **CVBS Video Output**

- Allows CVBS output of all source inputs

### **2D Graphics Engine**

- Hardware Graphics Engine for responsive interactive applications
- Supports point draw, line draw, rectangle draw/fill, text draw and trapezoid draw
- BitBlit, stretch BitBlit, trapezoid BitBlit, mirror BitBlit and rotate BitBlit
- Raster Operation (ROP)
- Support Porter-Duff

### **VIF Demodulator**

- Compliant with NTSC M/N, PAL B, G/H, I, D/K, SECAM L/L' standards
- Audio/Video dual-path processor
- Stepped-gain PGA with 25 dB tuning range and 1 dB tuning resolution
- Maximum IF gain of 37 dB
- Programmable TOP to accommodate different tuner gain and SAW filter insertion loss to optimize noise and linearity performance
- Multi-standard processing with single SAW
- Supports silicon tuner low IF output architecture

### **DVB-T/DVB-C Demodulator**

- Digital carrier frequency offset correction:  $\pm 500\text{kHz}$
- Optimised for SFN channels with pre/post-cursive echoes inside/outside the guard
- Acquisition range  $\pm 857\text{kHz}$  includes up to 3x:  $\pm 1/6\text{ MHz}$  transmitter offset
- Meets Nordig Unified 1.0.3, D-Book 5.0, EICTA E-Book/C-Book test requirement
- ITU J.83 Annex A/C, DVB-C (EN 300 429) compliant
- Supports DVB-C 0.7-7M Baud symbol rate



- $\pm 400\text{kHz}$  internal carrier offset recovery range
- 6.8  $\mu\text{s}$  echo cancellation at 7 Msym/s
- Supports IF, low-IF, zero-IF inputs
- Ultra-fast automatic blind UHF/VHF channel scan (constellations and symbol rate)

### Connectivity

- Two USB 2.0 host ports
- USB architecture designed for efficient support of external storage devices in conjunction with off air broadcasting

### Miscellaneous

- DRAM interface supporting two 16-bit DDR2 @ 1066MHz
- Supports PVR
- Supports Common Interface for conditional access support
- Bootable SPI interface with serial flash support
- Parallel interface for external OneNAND and NAND flash support
- Power control module with ultra low power
- MCU available in standby mode
- 523-ball LFBGA package
- Operating Voltages: 1.26V (core), 1.8V (DDR2), 2.5V and 3.3V (I/O and analog)

### 7.3. Reset Circuit

Reset circuit using for initializing main Mstar IC. Reset condition is high and normal working condition is low for RESET pin.

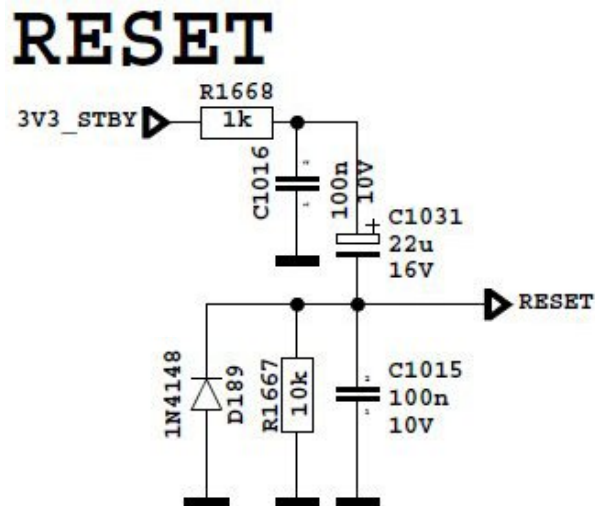

## 8. CI INTERFACE

### 7.1 Block Diagram

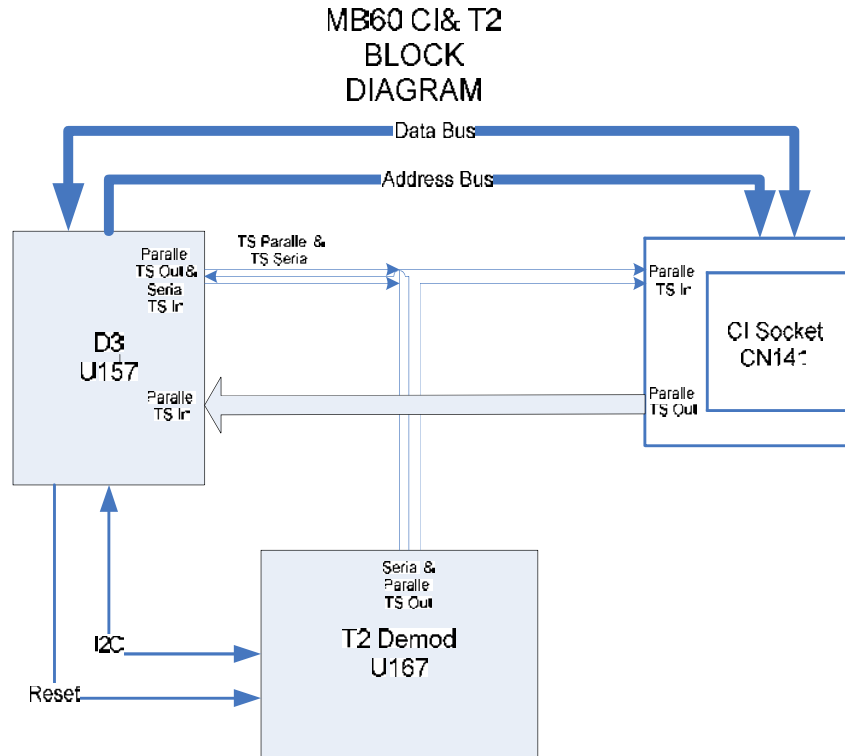

### 7.1 CI Interface Power Switch

It is used for CI module supply, when Module is inserted (it means CI detect is low) This circuit is opened or closed by CI\_POWER\_CTRL port of main uController

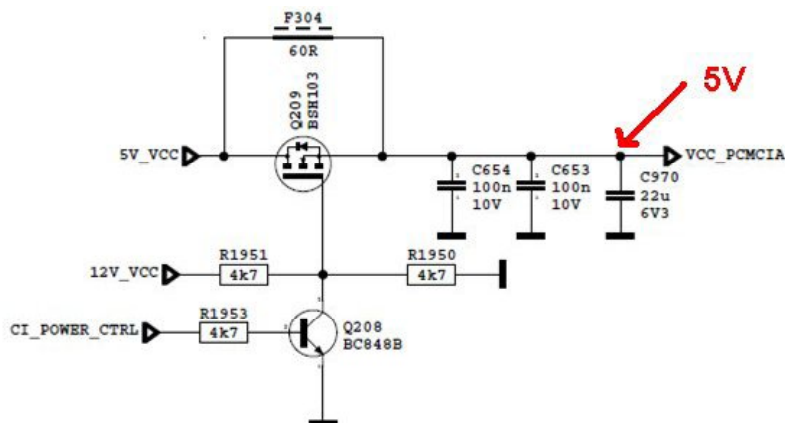

## 9. T2 Demodulator CXD2820R (U167)

### 9.1. General Description

This demodulator is optional for support T2 reception. The Sony CXD2820R is a combined DVB-T2, DVB-T and DVB-C demodulator that conforms to the ETSI EN 302-755 (second generation Terrestrial) ETSI EN 300-744 (Terrestrial) and ETSI EN 300-429 (Cable) standards.

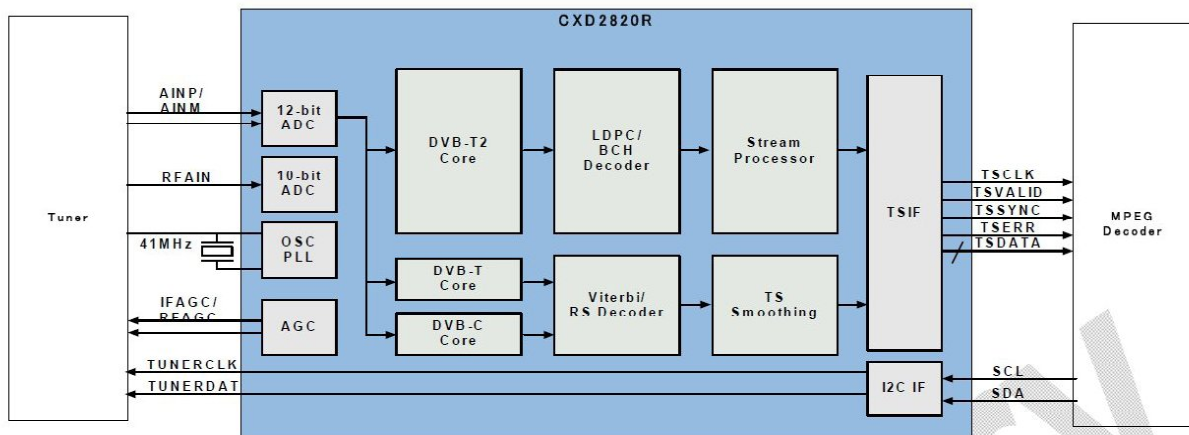

### 9.2. Features



- Single, 41MHz crystal (can be shared with CXD2813R analogue demod IC)
- High performance differential signal ADC
- RF power level monitor ADC
- Low IF and high IF (36MHz) mode input
- Fast 400kHz I2C compatible bus interface
- Quiet I2C interface for dedicated tuner control
- Automatic IF AGC and optional programmable
- RF AGC/GPIO functions
- Configurable parallel and serial MPEG-2 TS outputs with smoothing buffer
- 3.3V, 2.5V, 1.2V supplies
- Temperature range -20°C to +85°C
- Supplied with full reference design, including software driver, PCB schematic/layouts, GUI and documentation
- 3.3V for VDD and 2.5V for VDDQ power supply
- All inputs and outputs are compatible with SSTL\_2 interface
- JEDEC standard 400mil 66pin TSOP-II with 0.65mm pin pitch
- Fully differential clock inputs (CK, /CK) operation
- Double data rate interface
- Source synchronous - data transaction aligned to bidirectional data strobe (DQS)
- x16 device has 2 byte-wide data strobes (LDQS, UDQS) per each x8 I/O
- Data outputs on DQS edges when read (edged DQ) Data inputs on DQS centers when write (centered DQ)

- Data(DQ) and Write masks(DM) latched on the both rising and falling edges of the data strobe
- All addresses and control inputs except Data, Data strobes and Data masks latched on the rising edges of the clock
- Write mask byte controls by LDM and UDM
- Programmable /CAS latency 3 / 4 supported
- Programmable Burst Length 2 / 4 / 8 with both sequential and interleave mode
- Internal 4 bank operations with single pulsed /RAS
- tRAS Lock-Out function supported
- Auto refresh and self refresh supported
- 4096 refresh cycles / 32ms
- Full, Half and Matched Impedance(Weak) strength driver option controlled by EMRS

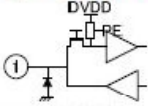
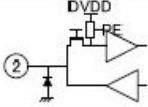
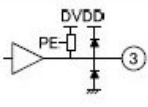
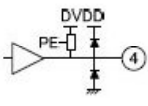
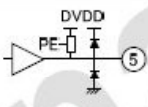
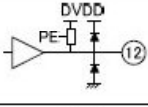
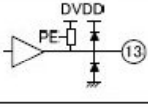
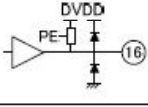
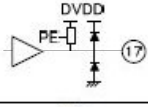
### 9.3. Pinning

Name	No.	I/O	Function	Equivalent Circuit	Note
GPIO0	1	I/O	General purpose I/O		5V tolerant Controllable pull-up
TSERR_GPIO2	2	O	TS error flag General purpose I/O		5V tolerant Controllable pull-up
TSSYNC	3	O	TS sync flag		Controllable pull-up Selectable output current
TSVALID	4	O	TS valid flag		Controllable pull-up Selectable output current
TSCLK	5	O	TS clock output		Controllable pull-up Selectable output current
VSS	6	—	Digital Ground	n/a	
CVDD	7	—	1.2V digital power supply	n/a	
MVDD	8	—	1.2V digital power supply	n/a	Supplies memory power
MVSS	9	—	Digital Ground	n/a	
VSS	10	—	Digital Ground	n/a	
DVDD	11	—	3.3V digital power supply	n/a	
TSDATA0	12	O	TS data output		Controllable pull-up Selectable output current
TSDATA1	13	O	TS data output		Controllable pull-up Selectable output current
CVDD	14	—	1.2V digital power supply	n/a	
VSS	15	—	Digital Ground	n/a	
TSDATA2	16	O	TS data output		Controllable pull-up Selectable output current
TSDATA3	17	O	TS data output		Controllable pull-up Selectable output current
MVSS	18	—	Digital Ground	n/a	
MVDD	19	—	1.2V digital power supply	n/a	Supplies memory power
CVDD	20	—	1.2V digital power supply	n/a	
VSS	21	—	Digital Ground	n/a	

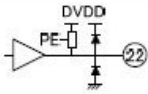
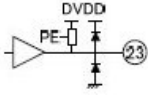
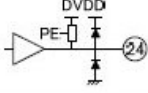
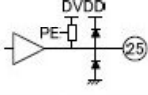
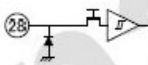
Name	No.	I/O	Function	Equivalent Circuit	Note
			supply		
MVSS	42	—	Digital Ground	n/a	
PVSS	43	—	Analog Ground	n/a	
PVDD	44	—	1.2V analog power supply	n/a	Supplies PLL power
XVDD	45	—	2.5V analog power supply	n/a	Supplies crystal oscillator power
XTALO	46	O	Crystal oscillator output		Leave open when external clock input to XTALI
XTALI	47	I	Crystal oscillator input		External clock input pin
XVSS	48	—	Analog Ground	n/a	
AINM	49	I	IF input (-)		
AINP	50	I	IF input (+)		
AVSS	51	—	Analog Ground	n/a	
AVDD	52	—	2.5V analog power supply	n/a	Supplies IF ADC power
RFAIN	53	I	RF level monitor		
RVDD	54	—	3.3V digital power supply (*1)	n/a	Supplies RF level monitor ADC power
VSS	55	—	Digital Ground	n/a	
CVDD	56	—	1.2V digital power supply	n/a	
TUNERDAT	57	I/O	Tuner I <sup>2</sup> C data		5V tolerant
TUNERCLK	58	O	Tuner I <sup>2</sup> C clock		5V tolerant
DVDD	59	—	3.3V digital power supply	n/a	
VSS	60	—	Digital Ground	n/a	
CVDD	61	—	1.2V digital power supply	n/a	
PLLBPN	62	I	PLL bypass		5V tolerant 1: Use PLL 0: Bypass PLL
RFAGC_GPIO1	63	I/O	RFAGC output General purpose I/O		PWM output 5V tolerant Controllable pull-up CAUTION: intermediate voltage input is prohibited.
IFAGC	64	O	IFAGC output		PWM output CAUTION: 5V input is prohibited.

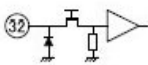
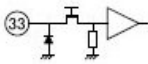
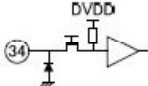
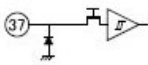
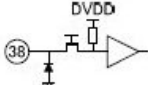
Name	No.	I/O	Function	Equivalent Circuit	Note
TSDATA4	22	O	TS data output		Controllable pull-up Selectable output current
TSDATA5	23	O	TS data output		Controllable pull-up Selectable output current
TSDATA6	24	O	TS data output		Controllable pull-up Selectable output current
TSDATA7	25	O	TS data output		Controllable pull-up Selectable output current
VSS	26	—	Digital Ground	n/a	
DVDD	27	—	3.3V digital power supply	n/a	
SCL	28	I	I <sup>2</sup> C clock		5V tolerant
SDA	29	I/O	I <sup>2</sup> C data		5V tolerant
CVDD	30	—	1.2V digital power supply	n/a	
VSS	31	—	Digital Ground	n/a	
TESTMODE	32	I	Test mode setting		5V tolerant 1: Test mode 0: Normal mode
A0	33	I	I <sup>2</sup> C slave address selection		5V tolerant
OSCENBN	34	I	Oscillator enable		5V tolerant 1: Stop 0: Run
VSS	35	—	Digital Ground	n/a	
CVDD	36	—	1.2V digital power supply	n/a	
RESETN	37	I	Hardware reset		5V tolerant
OSCMODE	38	I	3rd overtone crystal selection		5V tolerant 1: fundamental 0: 3rd overtone
MVSS	39	—	Digital Ground	n/a	
MVDD	40	—	1.2V digital power supply	n/a	Supplies memory power
MVDD	41	—	1.2V digital power	n/a	Supplies memory power

## 10. USB INTERFACE

Main Concept IC has integrated 2 USB 2.0 interface. One of them is used for ethernet function, the other one is used for USB connectivity for last user. Last user can play video, picture and audio files. Also digital channels can be record to external storage device by this interface. All SW files can be updated with interface.

USB circuit has 3 main parts

- Integrated USB 2.0 Host interface of D3 (U157)
- Protection IC (U145)
- Over Current Protection IC (U149)

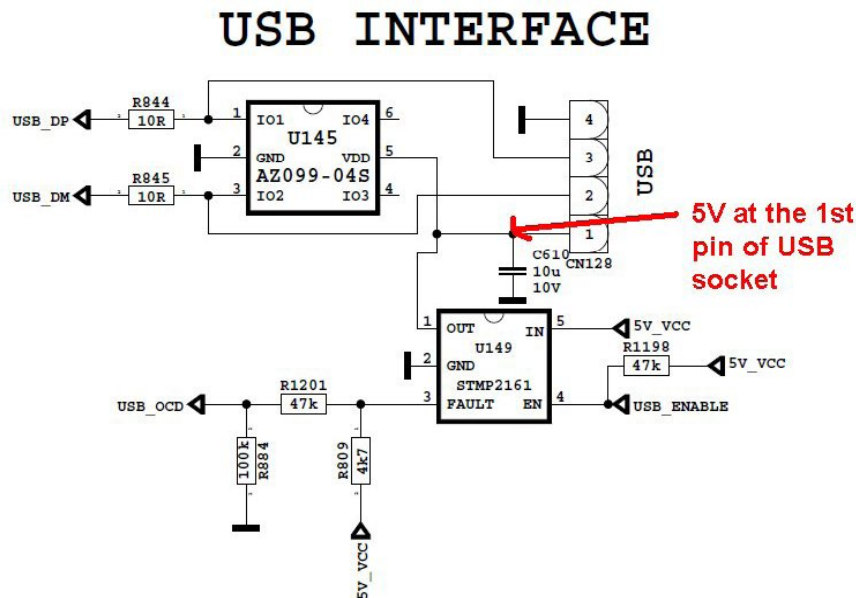

## 11. DDR2 SDRAM 8M × 4 BANKS × 16 BIT (W9751G6JB) (U154, U155)

### 11.1. General Description

The W9751G6JB is a 512M bits DDR2 SDRAM, organized as 8,388,608 words × 4 banks × 16 bits. This device achieves high speed transfer rates up to 1066Mb/sec/pin (DDR2-1066) for general applications. W9751G6JB is sorted into the following speed grades: -18, -25 and -3. The -18 is compliant to the DDR2-1066/CL7 specification. The -25 is compliant to the DDR2-800 (5-5-5) or DDR2-800 (6-6-6) specification. The -3 is compliant to the DDR2-667 (5-5-5) specification. All of the control and address inputs are synchronized with a pair of externally supplied differential clocks. Inputs are latched at the cross point of differential clocks (CLK rising and CLK falling). All I/Os are synchronized with a single ended DQS or differential DQS- DQS pair in a source synchronous fashion.



## 11.2. Features

- Power Supply: VDD, VDDQ = 1.8 V $\pm$  0.1 V
- Double Data Rate architecture: two data transfers per clock cycle
- CAS Latency: 3, 4, 5, 6 and 7
- Burst Length: 4 and 8
- Bi-directional, differential data strobes (DQS and DQS ) are transmitted / received with data
- Edge-aligned with Read data and center-aligned with Write data
- DLL aligns DQ and DQS transitions with clock
- Differential clock inputs (CLK and CLK )
- Data masks (DM) for write data
- Commands entered on each positive CLK edge, data and data mask are referenced to both edges of DQS
- Posted CAS programmable additive latency supported to make command and data bus efficiency
- Read Latency = Additive Latency plus CAS Latency (RL = AL + CL)
- Off-Chip-Driver impedance adjustment (OCD) and On-Die-Termination (ODT) for better signal quality
- Auto-precharge operation for read and write bursts
- Auto Refresh and Self Refresh modes
- Precharged Power Down and Active Power Down
- Write Data Mask
- Write Latency = Read Latency - 1 (WL = RL - 1)
- Interface: SSTL\_18

## 11.3. Electrical Characteristics

SYM.	PARAMETER	MIN.	TYP.	MAX.	UNIT	NOTES
VDD	Supply Voltage	1.7	1.8	1.9	V	1
VDDL	Supply Voltage for DLL	1.7	1.8	1.9	V	5
VDDQ	Supply Voltage for Output	1.7	1.8	1.9	V	1, 5
VREF	Input Reference Voltage	0.49 x VDDQ	0.5 x VDDQ	0.51 x VDDQ	V	2, 3
VTT	Termination Voltage (System)	VREF - 0.04	VREF	VREF + 0.04	V	4

## 11.4. Pinning

1	2	3	4	5	6	7	8	9
VDD	NC	VSS		A		VSSQ	$\overline{\text{UDQS}}$	VDDQ
DQ14	VSSQ	UDM		B		UDQS	VSSQ	DQ15
VDDQ	DQ9	VDDQ		C		VDDQ	DQ8	VDDQ
DQ12	VSSQ	DQ11		D		DQ10	VSSQ	DQ13
VDD	NC	VSS		E		VSSQ	$\overline{\text{LDQS}}$	VDDQ
DQ6	VSSQ	LDM		F		LDQS	VSSQ	DQ7
VDDQ	DQ1	VDDQ		G		VDDQ	DQ0	VDDQ
DQ4	VSSQ	DQ3		H		DQ2	VSSQ	DQ5
VDDL	VREF	VSS		J		VSSDL	CLK	VDD
	CKE	$\overline{\text{WE}}$		K		$\overline{\text{RAS}}$	$\overline{\text{CLK}}$	ODT
NC	BA0	BA1		L		$\overline{\text{CAS}}$	$\overline{\text{CS}}$	
	A10/AP	A1		M		A2	A0	VDD
VSS	A3	A5		N		A6	A4	
	A7	A9		P		A11	A8	VSS
VDD	A12	NC		R		NC	NC	

BALL NUMBER	SYMBOL	FUNCTION	DESCRIPTION
M8,M3,M7,N2,N8,N3,N7,P2,P8,P3,M2,P7,R2	A0–A12	Address	Provide the row address for active commands, and the column address and Auto-precharge bit for Read/Write commands to select one location out of the memory array in the respective bank. Row address: A0–A12. Column address: A0–A9. (A10 is used for Auto-precharge)
L2,L3	BA0–BA1	Bank Select	BA0–BA1 define to which bank an ACTIVE, READ, WRITE or PRECHARGE command is being applied.
G8,G2,H7,H3,H1,H9,F1,F9,C8,C2,D7,D3,D1,D9,B1,B9	DQ0–DQ15	Data Input / Output	Bi-directional data bus.
K9	ODT	On Die Termination Control	ODT (registered HIGH) enables termination resistance internal to the DDR2 SDRAM.
F7,E8	LDQS, LDQS	LOW Data Strobe	Data Strobe for Lower Byte: Output with read data, input with write data for source synchronous operation. Edge-aligned with read data, center-aligned with write data. LDQS corresponds to the data on DQ0–DQ7. LDQS is only used when differential data strobe mode is enabled via the control bit at EMR (1)[A10 EMRS command].
B7,A8	UDQS, UDQS	UP Data Strobe	Data Strobe for Upper Byte: Output with read data, input with write data for source synchronous operation. Edge-aligned with read data, center-aligned with write data. UDQS corresponds to the data on DQ8–DQ15. UDQS is only used when differential data strobe mode is enabled via the control bit at EMR (1)[A10 EMRS command].
L8	CS	Chip Select	All commands are masked when CS is registered HIGH. CS provides for external bank selection on systems with multiple ranks. CS is considered part of the command code.
K7,L7,K3	RAS, CAS, WE	Command Inputs	RAS, CAS and WE (along with CS) define the command being entered.
B3,F3	UDM LDM	Input Data Mask	DM is an input mask signal for write data. Input data is masked when DM is sampled high coincident with that input data during a Write access. DM is sampled on both edges of DQS. Although DM pins are input only, the DM loading matches the DQ and DQS loading.
J8,K8	CLK, CLK	Differential Clock Inputs	CLK and CLK are differential clock inputs. All address and control input signals are sampled on the crossing of the positive edge of CLK and negative edge of CLK. Output (read) data is referenced to the crossings of CLK and CLK (both directions of crossing).
K2	CKE	Clock Enable	CKE (registered HIGH) activates and CKE (registered LOW) deactivates clocking circuitry on the DDR2 SDRAM.
J2	VREF	Reference Voltage	VREF is reference voltage for inputs.
A1,E1,J9,M9,R1	VDD	Power Supply	Power Supply: 1.8V ± 0.1V.
A3,E3,J3,N1,P9	VSS	Ground	Ground.
A9,C1,C3,C7,C9,E9,G1,G3,G7,G9	VDDQ	DQ Power Supply	DQ Power Supply: 1.8V ± 0.1V.
A7,B2,B8,D2,D8,E7,F2,F8,H2,H8	VSSQ	DQ Ground	DQ Ground. Isolated on the device for improved noise immunity.
A2,E2,L1,R3,R7,R8	NC	No Connection	No connection.
J7	VSSDL	DLL Ground	DLL Ground.
J1	VDDL	DLL Power Supply	DLL Power Supply: 1.8V ± 0.1V.

## 12. SCALER AND LVDS SOCKETS

### 12.1. LVDS sockets Block Diagram

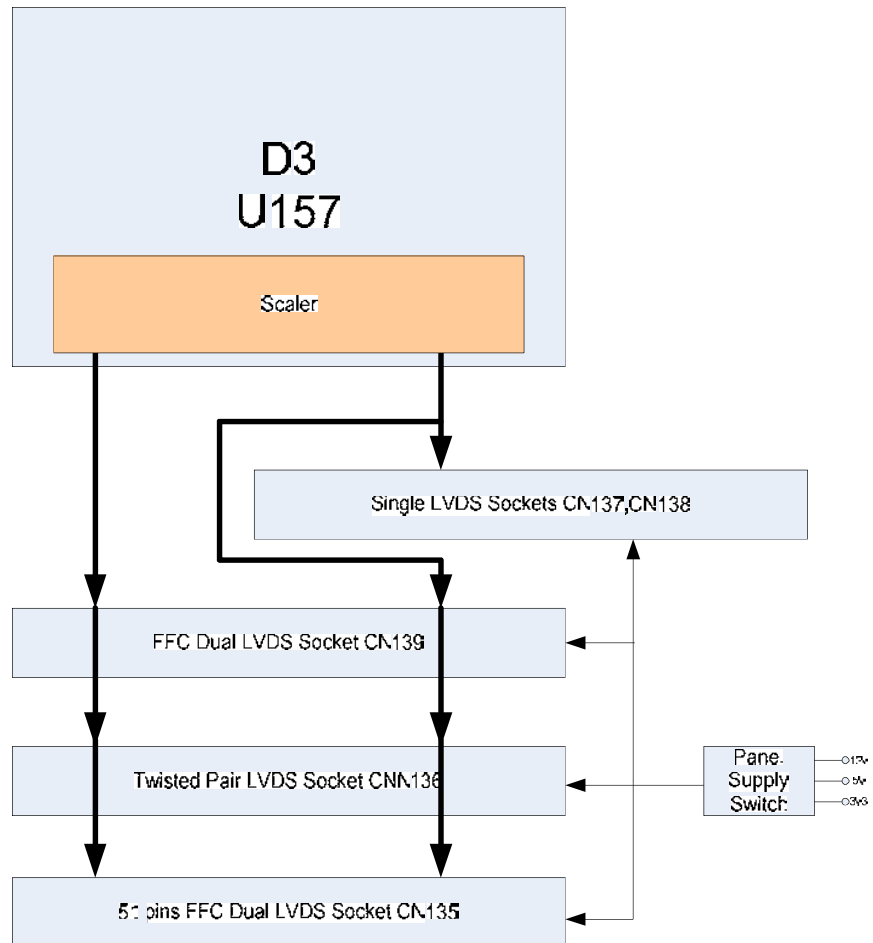

### 12.2. Panel Supply Switch Circuit

This switch is used to open and close panel supply of TCON. It is controlled by port of main ucontroller. Also with this circuit panel sequency could be adjusted correctly. 3 panel suplys are connected to this circuit. All of them are optional according to panels.

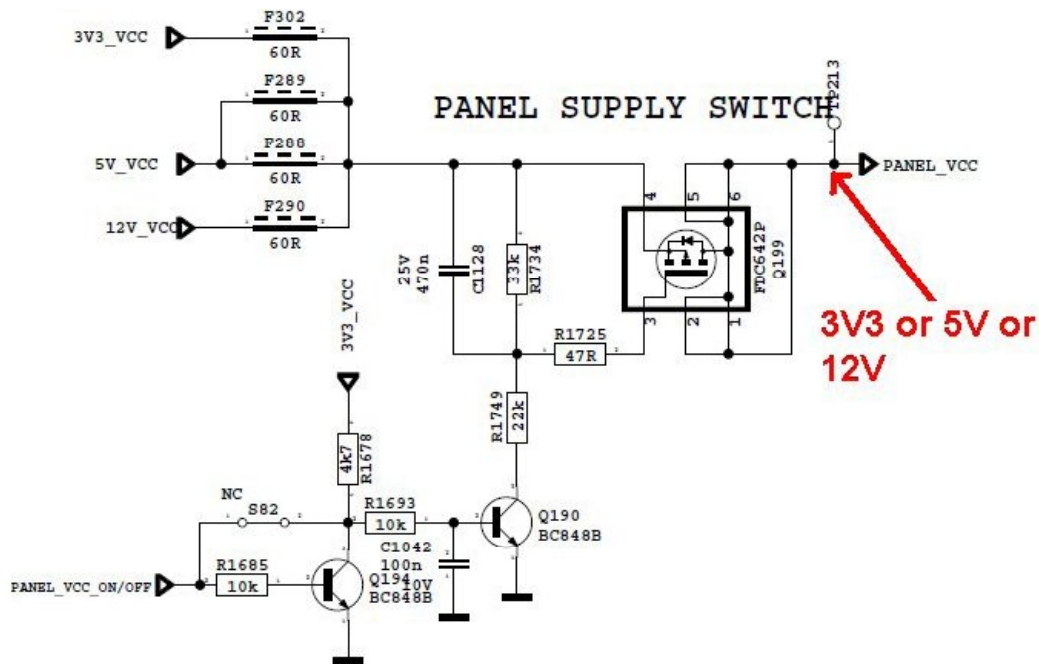

## 13. NAND FLASH MEMORY - MX25L1005 (U158)

### 13.1. General Description

MX25L1005 is a CMOS 1,048,576 bit serial Flash memory, which is configured as 131,072 x 8 internally. The MX25L1005 feature a serial peripheral interface and software protocol allowing operation on a simple 3-wire bus. The three bus signals are a clock input (SCLK), a serial data input (SI), and a serial data output (SO). SPI access to the device is enabled by CS# input. The MX25L1005 provide sequential read operation on whole chip. After program/erase command is issued, auto program/ erase algorithms which program/ erase and verify the specified page or sector/block locations will be executed. Program command is executed on page (256 bytes) basis, and erase command is executes on chip or sector(4K-bytes) or block(64K-bytes). To provide user with ease of interface, a status register is included to indicate the status of the chip. The status read command can be issued to detect completion status of a program or erase operation via WIP bit. When the device is not in operation and CS# is high, it is put in standby mode and draws less than 10uA DC current. The MX25L1005 utilize MXIC's proprietary memory cell, which reliably stores memory contents even after 100,000 program and erase cycles.

### 13.2. Features

- Serial Peripheral Interface (SPI) compatible -- Mode 0 and Mode 3
- 1,048,576 x 1 bit structure
- 32 Equal Sectors with 4K byte each, Any Sector can be erased individually
- 2 Equal Blocks with 64K byte each, Any Block can be erased individually
- Single Power Supply Operation

- 2.7 to 3.6 volt for read, erase, and program operations
- Latch-up protected to 100mA from -1V to Vcc +1V
- Low Vcc write inhibit is from 1.5V to 2.5V

### 13.3. Absolute Maximum Ratings

RATING	VALUE
Ambient Operating Temperature	0°C to 70°C
Storage Temperature	-55°C to 125°C
Applied Input Voltage	-0.5v to 4.6v
Applied Output Voltage	-0.5v to 4.6v
VCC to Ground Potential	-0.5v to 4.6v

### 13.4. Pinning

8-PIN SOP (150mil)

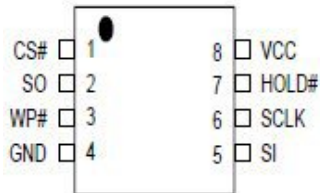

SYMBOL	DESCRIPTION
CS#	Chip select
SI	Serial Data Input
SO	Serial Data Output
SCLK	Clock Input
HOLD#	Hold, to pause the device without deselecting the device
VCC	+3.3v Power Supply
GND	Ground

## 14. NAND FLASH MEMORY – NAND512XXA2C (U162)

### 14.1. General Description

The NAND flash 528-byte/ 264-word page is a family of non-volatile flash memories that uses the single level cell (SLC) NAND technology. It is referred to as the small page family.

The NAND512R3A2C, NAND512R4A2C, and NAND512W3A2C have a density of 512 Mbits and operate with either a 1.8 V or 3 V voltage supply. The size of a page is either 528 bytes (512 + 16 spare) or 264 words (256 + 8 spare) depending on whether the device has a x8 or x16 bus width.

The address lines are multiplexed with the Data Input/Output signals on a multiplexed x8 or x16 input/output bus. This interface reduces the pin count and makes it possible to migrate to other densities without changing the footprint.

To extend the lifetime of NAND flash devices it is strongly recommended to implement an error correction code (ECC). The use of ECC correction allows to achieve up to 100,000 program/erase cycles for each block. A write protect pin is available to give a hardware protection against program and erase operations.

### 14.2. Features

- High density NAND flash memories
  - 512-Mbit memory array
  - Cost effective solutions for mass storage applications
- NAND interface
  - x8 or x16 bus width
  - Multiplexed address/ data
- Supply voltage: 1.8 V, 3 V
- Page size
  - x8 device: (512 + 16 spare) bytes
  - x16 device: (256 + 8 spare) words
- Block size
  - x8 device: (16K + 512 spare) bytes
  - x16 device: (8K + 256 spare) words
- Page read/program
  - Random access: 12  $\mu$ s (3 V)/15  $\mu$ s (1.8 V) (max)
  - Sequential access: 30 ns (3 V)/50 ns (1.8 V) (min)
  - Page program time: 200  $\mu$ s (typ)
- Copy back program mode
- Fast block erase: 2 ms (typ)

- Status register
- Electronic signature
- Chip Enable 'don't care'
- Security features
  - OTP area
- Serial number (unique ID) option
- Hardware data protection
  - Program/erase locked during power transitions
- Data integrity
  - 100,000 program/erase cycles (with ECC)
  - 10 years data retention
- RoHS compliant packages
- Development tools
  - Error correction code models
  - Bad blocks management and wear leveling algorithms

### 14.3. Pinning

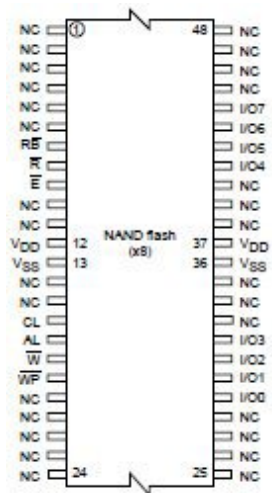



## **15. USB2.0 to Fast Ethernet – ASIX AX88X72A (U171)**

### **15.1. General Description**

The AX88772A/AX88172A Low-pin-count USB 2.0 to 10/100M Fast Ethernet controller is a high performance and highly integrated ASIC which enables low cost, small form factor, and simple plug-and-play Fast Ethernet network connection capability for desktops, notebook PC's, Ultra-Mobile PC's, docking stations, game consoles, digital-home appliances, and any embedded system using a standard USB port.

The AX88772A/AX88172A features a USB interface to communicate with a USB Host Controller and is compliant with USB specification V1.1 and V2.0. The AX88772A/AX88172A implements 10/100Mbps Ethernet LAN function based on IEEE802.3, and IEEE802.3u standards with 24KB of embedded SRAM for packet buffering. The AX88772A/AX88172A integrates an on-chip 10/100Mbps Ethernet PHY to simplify system design.

The AX88172A provides an optional External Media Interface (EMI) for external PHY or external MAC for different application purposes. The EMI can be a media-independent interface (MII) for implementing 10BASE-FX Ethernet or HomePNA functions. The EMI can also be a Reverse-MII or Reverse Reduced-MII (Reverse-RMII) for glueless MAC-to-MAC connections to any MCU with Ethernet MAC MII or RMII interface. In addition, the EMI can be configured to Dual-PHY mode allowing AX88172A to act as an Ethernet PHY or USB 2.0 PHY for external MAC device that needs Ethernet and USB interfaces in their system applications. The optional serial interface such as I2C, SPI, and UART are provided as a control channel from the USB Host Controller to communicate with the external MCU chip.

### **15.2. Features**

Single chip USB 2.0 to 10/100M Fast Ethernet controller – AX88772A

#### **USB Device Interface**

- Integrates on-chip USB 2.0 transceiver and SIE compliant to USB Spec 1.1 and 2.0
- Supports USB Full and High Speed modes with Bus-Power or Self-Power capability
- Supports 4 or 6 programmable endpoints on USB interface
- High performance packet transfer rate over USB bus using proprietary burst transfer mechanism
- Supports USB to Ethernet bridging or vice versa in hardware

#### **Fast Ethernet Controller**

- Integrates 10/100Mbps Fast Ethernet MAC/PHY
- IEEE 802.3 10BASE-T/100BASE-TX compatible
- Supports twisted pair crossover detection and auto-correction (HP Auto-MDIX)
- Embedded 16KB SRAM for RX packet buffering and 8KB SRAM for TX packet buffering
- Supports both Full-duplex with flow control and

- Half-duplex with backpressure operation
- Supports 2 VLAN ID filtering, received VLAN Tag (4 bytes) can be stripped off or preserved MAC/PHY loop-back diagnostic capability

#### **Support Wake-on-LAN Function**

- Supports Suspend Mode and Remote Wakeup via Link-up, Magic packet, MS wakeup frame and external pin
- Optional PHY power down during Suspend Mode

#### **Versatile External Media Interface**

- Optional MII interface in MAC mode allows AX88172A to work with external 100BASE-FX Ethernet PHY or HomePNA PHY
- Optional Reverse-MII or Reverse-RMII interface in PHY mode allows AX88172A to work with external HomePlug PHY or glueless MAC-to-MAC connections
- Optional Reverse-MII interface in Dual-PHY mode allows AX88172A to act as an Ethernet PHY or USB 2.0 PHY for external MAC device that needs Ethernet and USB in system application

- Supports 256/512 bytes (93c56/93c66) of serial EEPROM (for storing USB Descriptors)
- Supports automatic loading of Ethernet ID, USB Descriptors and Adapter Configuration from EEPROM after power-on initialization
- Provides optional serial interface, I2C, SPI and UART
- Integrates on-chip voltage regulator and only requires a single 3.3V power supply
- 12MHz and 25Mhz clock input from either crystal or oscillator source
- Integrates on-chip power-on reset circuit

### **15.3. Block Diagram**

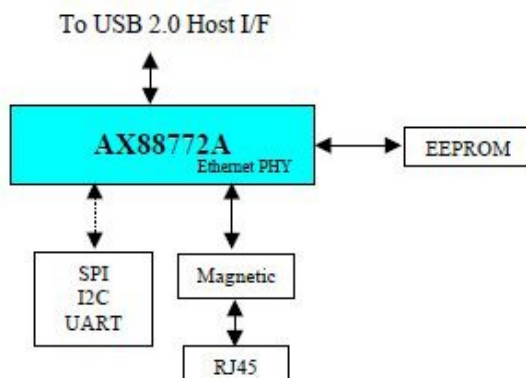

## 15.4. Pinning

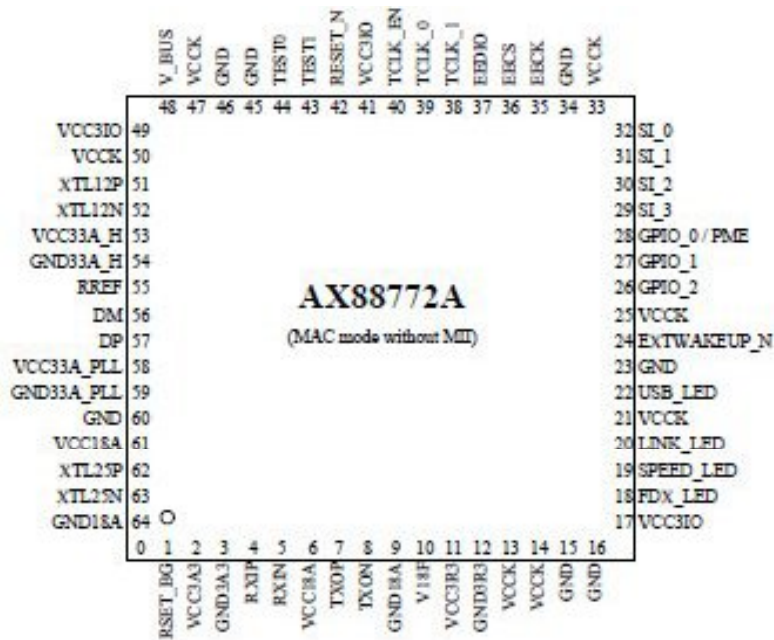

## 16. LM1117(U175, U180, U181)

### 16.1. General Description

The LM1117 is a series of low dropout voltage regulators with a dropout of 1.2V at 800mA of load current. It has the same pin-out as National Semiconductor's industry standard LM317. The LM1117 is available in an adjustable version, which can set the output voltage from 1.25V to 13.8V with only two external resistors. In addition, it is also available in five fixed voltages, 1.8V, 2.5V, 2.85V, 3.3V, and 5V. The LM1117 offers current limiting and thermal shutdown. Its circuit includes a zener trimmed bandgap reference to assure output voltage accuracy to within  $\pm 1\%$ . The LM1117 series is available in SOT-223, TO-220, and TO-252 D-PAK packages. A minimum of 10 $\mu$ F tantalum capacitor is required at the output to improve the transient response and stability.

### 16.2. Features

- Available in 1.8V, 2.5V, 2.85V, 3.3V, 5V, and Adjustable Versions
- Space Saving SOT-223 Package
- Current Limiting and Thermal Protection
- Output Current 800mA
- Line Regulation 0.2% (Max)
- Load Regulation 0.4% (Max)
- Temperature Range
- LM1117 0°C to 125°C
- LM1117I -40°C to 125°C

### 16.3. Applications

- 2.85V Model for SCSI-2 Active Termination
- Post Regulator for Switching DC/DC Converter
- High Efficiency Linear Regulators 15
- 32" TFT TV Service Manual 10/01/2005
- Battery Charger
- Battery Powered Instrumentation

### 16.4. Absolute Maximum Ratings

CHARACTERISTIC	SYMBOL	MIN.	MAX.	UNIT
DC Input Voltage	$V_{IN}$		7	V
Lead Temperature (Soldering, 5 Seconds)	$T_{SOL}$		260	°C
Storage Temperature Range	$T_{STG}$	-65	150	°C
Operating Junction Temperature Range	$T_{OPR}$	0	125	°C

### 16.5. Pinning

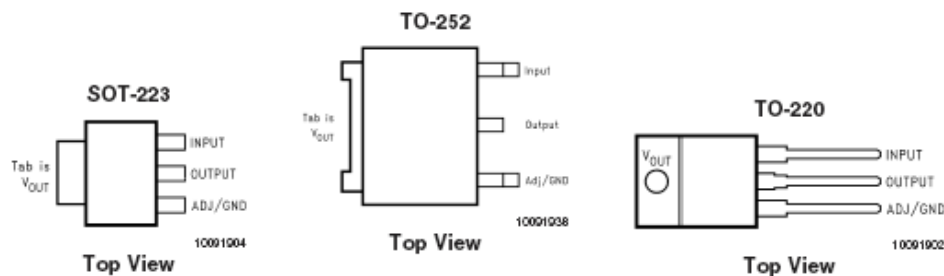

## 17. MP2012 (U176)

### 17.1. General Description

The MP2012 is a fully integrated, internally compensated 1.2MHz fixed frequency PWM step-down converter. It is ideal for powering portable equipment that runs from a single cell Lithium-Ion (Li+) Battery, with an input range from 2.7V to 6V. The MP2012 can provide up to 1.5A of load current with output voltage as low as 0.8V. It can also operate at 100% duty cycle for low dropout applications. With peak current mode control and internal compensation, the MP2012 is stable with ceramic capacitors and small inductors. Fault condition protection includes cycle-by-cycle current limiting and thermal shutdown.

### 17.2. Features

- 2.7-6V Input Operation Range
- Output Adjustable from 0.8V to  $V_{IN}$
- 1 $\mu$ A Max Shutdown Current.
- Up to 95% Efficiency

- 100% Duty Cycle for Low Dropout
- Applications
- 1.2MHz Fixed Switching Frequency
- Stable with Low ESR Output Ceramic
- Capacitors
- Thermal Shutdown
- Cycle-by-Cycle Over Current Protection
- Short Circuit Protection
- Available in 6-pin 3x3mm QFN

### 17.3. Pinning

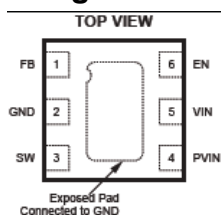

Pin #	Name	Description
1	FB	Feedback input. An external resistor divider from the output to GND, tapped to the FB pin sets the output voltage.
2	GND, Exposed Pad	Ground pin. Connect exposed pad to ground plane for proper thermal performance.
3	SW	Switch node to the inductor.
4	PVIN	Input supply pin for power FET.
5	VIN	Input Supply pin for controller. Put small decoupling ceramic near this pin.
6	EN	Enable input, "High" enables MP2012. EN is pulled to GND with 1Meg internal resistor.

## 18. RTA8283A (U23, U173)

### 18.1. General Description

The RT8283A is a high-efficiency, monolithic synchronous step-down DC/DC converter that can deliver up to 3A output current from a 4.5V to 23V input supply. The RT8283A's current mode architecture and external compensation allow the transient response to be optimized over a wide range of loads and output capacitors. Cycle-by-cycle current limit provides protection against shorted outputs and soft-start eliminates input current surge during start-up. The RT8283A also provides output under voltage protection and thermal shutdown protection. The low current (<math><3\mu\text{A}</math>) shutdown mode provides output disconnect, enabling easy power management in battery-powered systems. The RT8283A is available in a SOP-8 package.

## 18.2. Features

- $\pm 1.5\%$  High Accuracy Feedback Voltage
- Integrated N-MOSFET Switches
- Current Mode Control
- Fixed Frequency Operation : 340kHz
- Output Adjustable from 0.8V to 20V
- Up to 95% Efficiency
- Thermal Shutdown Protection

## 18.3. Pinning

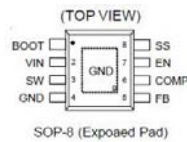

Pin No.	Pin Name	Description
1	BOOT	Bootstrap for high-side gate driver. Connect a 0.1 $\mu$ F or greater ceramic capacitor from BOOT to SW pins.
2	VIN	Input Supply 4.5V to 23V. Must bypass with a suitably large ceramic capacitor.
3	SW	Phase Node--Connect to external L-C filter..
4, 9 (Exposed Pad)	GND	Ground.
5	FB	Feedback Input pin is connected to the converter output. It is used to set the output of the converter to regulate to the desired value via an internal res divider. For an adjustable output, an external res divider is connected to this pin.
6	COMP	Compensation Node. COMP is used to compensate the regulation Control loop. Connect a series RC network from COMP to GND. In some cases, an additional capacitor from COMP to GND is required.
7	EN	Enable Input Pin. Logic high enables the converter; a logic low forces the RT8253A into shutdown mode. Attach this pin to VIN with a 100k $\Omega$ pull up resistor for automatic startup.
8	SS	Soft-Start Control Input. SS controls the soft-start period. Connect a capacitor from SS to GND to set the soft-start period. A 0.1 $\mu$ F capacitor sets the soft-start period to 13.5ms.

## 19. MP1583 (U174)

### 19.1. General Description

The MP1583 is a step-down regulator with a built-in internal Power MOSFET. It achieves 3A of continuous output current over a wide input supply range with excellent load and line regulation. Current mode operation provides fast transient response and eases loop

stabilization. Fault condition protection includes cycle-by-cycle current limiting and thermal shutdown. An adjustable soft-start reduces the stress on the input source at start-up. The MP1583 requires a minimum number of external components, providing a compact solution.

## 19.2. Features

- 3A Output Current
- Programmable Soft-Start
- 100mΩ Internal Power MOSFET Switch
- Stable with Low ESR Output Ceramic Capacitors
- Up to 95% Efficiency
- 20μA Shutdown Mode
- Fixed 385KHz Frequency
- Thermal Shutdown
- Cycle-by-Cycle Over Current Protection
- Wide 4.75V to 23V Operating Input Range
- Output Adjustable from 1.22V to 21V
- Under-Voltage Lockout

## 19.3. Pinning

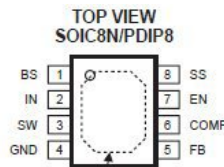

Pin No.	Pin Name	Description
1	BOOT	High-Side Gate Drive Bootstrap Input. BS supplies the drive for the high-side N-Channel MOSFET switch.
2	IN	Power Input. Drive IN with a 4.75V to 23V power source.
3	SW	Power Switching Out is the switching node that supplies power to the output
4	GND	Ground.
5	FB	Feedback Input. FB senses the output voltage and regulates it. Drive FB with a resistive voltage divider from the output voltage. FB threshold is 1.222V.
6	COMP	Compensation Node is used to compensate the regulation control loop.
7	EN	Enable/UVLO. A voltage greater than 2.71V enables operation. For complete low current shutdown the EN pin voltage needs to be at less than 900mV. When the voltage on EN exceeds 1.2V, the internal regulator will be enabled and the soft-start capacitor will begin to charge. The MP1583 will start switching after the EN pin voltage reaches 2.71V.
8	SS	Soft-Start Control Input. SS controls the soft-start period.

## 20. FDC642

### 20.1. General Description

This P-Channel 2.5V specified MOSFET is produced using Fairchild's advanced PowerTrench® process that has been especially tailored to minimize on-state resistance and yet maintain low gate charge for superior switching performance.

These devices have been designed to offer exceptional power dissipation in a very small footprint for applications where the larger packages are impractical.

### 20.2. Features

- Max  $r_{DS(on)}$  = 65 m $\Omega$  at  $V_{GS} = -4.5$  V,  $I_D = -4.0$  A
- Max  $r_{DS(on)}$  = 100 m $\Omega$  at  $V_{GS} = -2.5$  V,  $I_D = -3.2$  A
- Fast switching speed
- Low gate charge (11nC typical)
- High performance trench technology for extremely low  $r_{DS(on)}$
- SuperSOTTM-6 package: small footprint (72% smaller than standard SO-8); low profile (1 mm thick)
- Termination is Lead-free and RoHS Compliant

### 20.3. Pinning

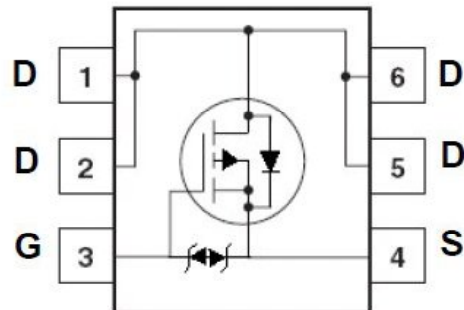
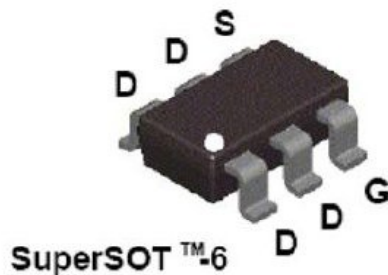

## 21. FDC604P

### 21.1. General Description

This P-Channel 1.8V specified MOSFET uses Fairchild's low voltage PowerTrench process. It has been optimized for battery power management applications.

### 21.2. Features

- -5.5 A, -20 V.  $R_{DS(ON)} = 33$  m $\Omega$  @  $V_{GS} = -4.5$  V
- $R_{DS(ON)} = 43$  m $\Omega$  @  $V_{GS} = -2.5$  V
- $R_{DS(ON)} = 60$  m $\Omega$  @  $V_{GS} = -1.8$  V
- Fast switching speed.
- High performance trench technology for extremely low  $R_{DS(ON)}(S)$



### 21.3. Pinning

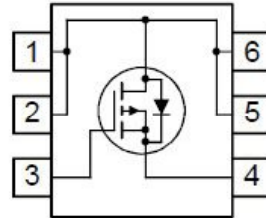
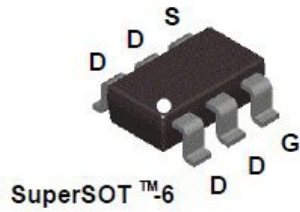

## 22. CONNECTORS

### 22.1. SCART (SC1)

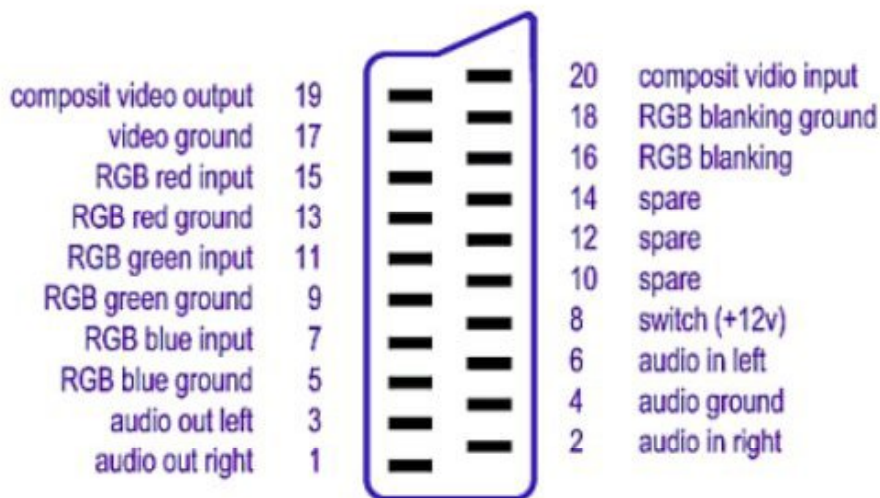

### 22.2. HDMI (CN707,CN708)

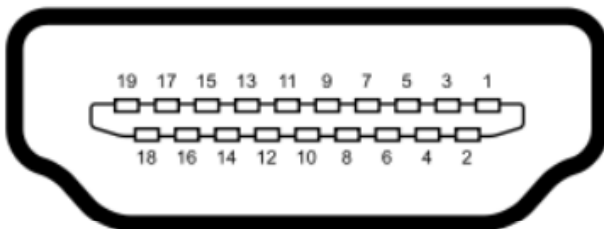

Pin Number	Signal Name	Pin Number	Signal Name
1	TMDS Data 2+	20	SHELL
2	TMDS Data 2 Shield	19	Hot Plug Detect
3	TMDS Data 2-	18	+5V Power
4	TMDS Data 1+	17	Ground
5	TMDS Data 1 Shield	16	DDC Data
6	TMDS Data 1-	15	DDC Clock
7	TMDS Data 0+	14	No Connect
8	TMDS Data 0 Shield	13	CEC
9	TMDS Data 0-	12	TMDS Clock-
10	TMDS Clock+	11	TMDS Clock Shield

### 22.3. VGA (CN132)

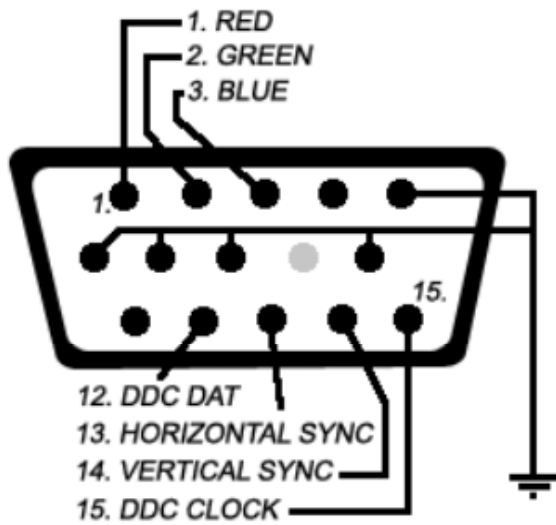

# MB60/IPS17 Interconnect

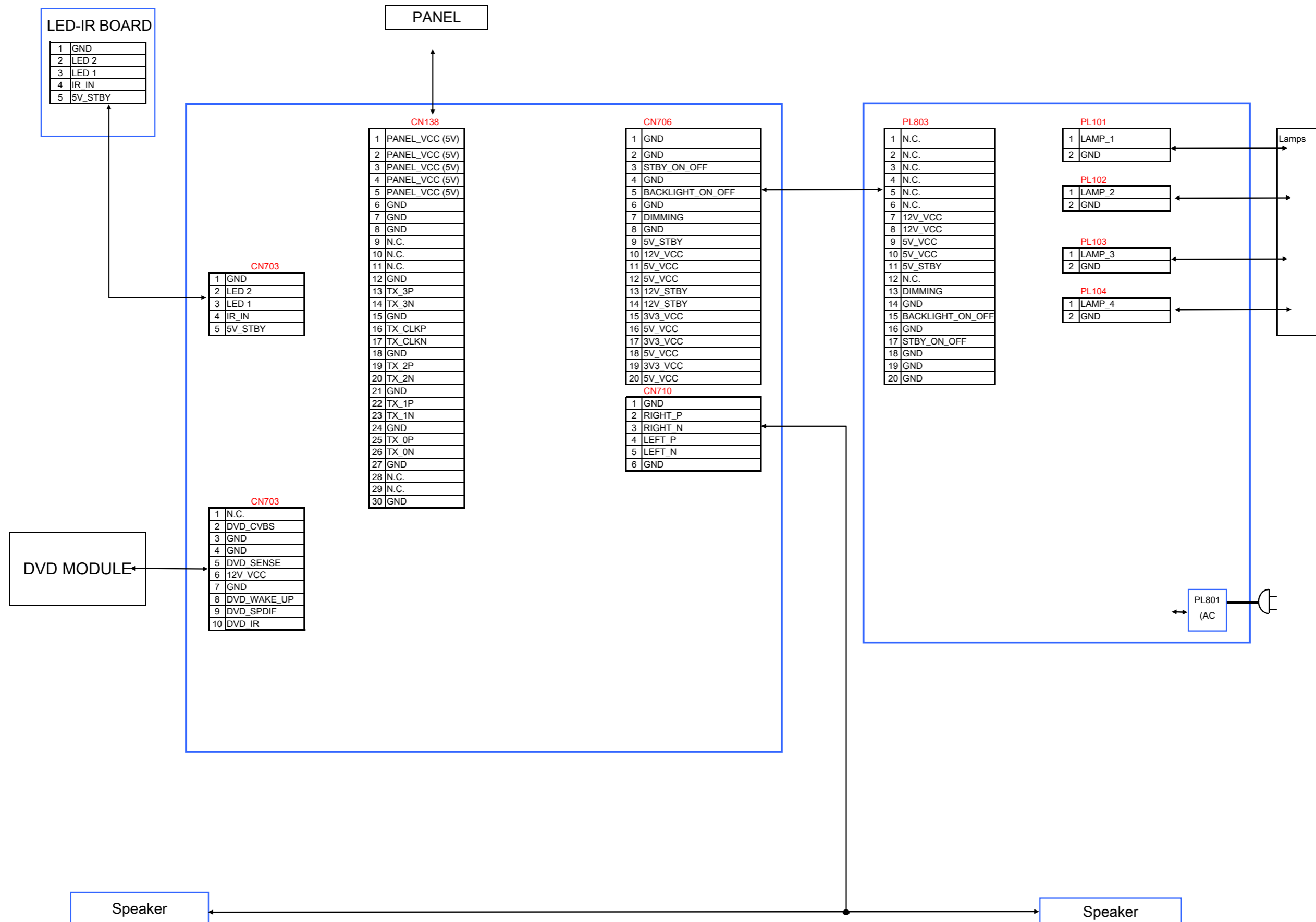

## 23. TROUBLESHOOTING

### 23.1. No Backlight Problem

Problem: If TV is working, led is normal and there is no picture and backlight on the panel.

Possible causes: Backlight pin, dimming pin, backlight supply, stby on/off pin

Backlight pin should be high in open position. If it is low, please check Q181 and panel cables.

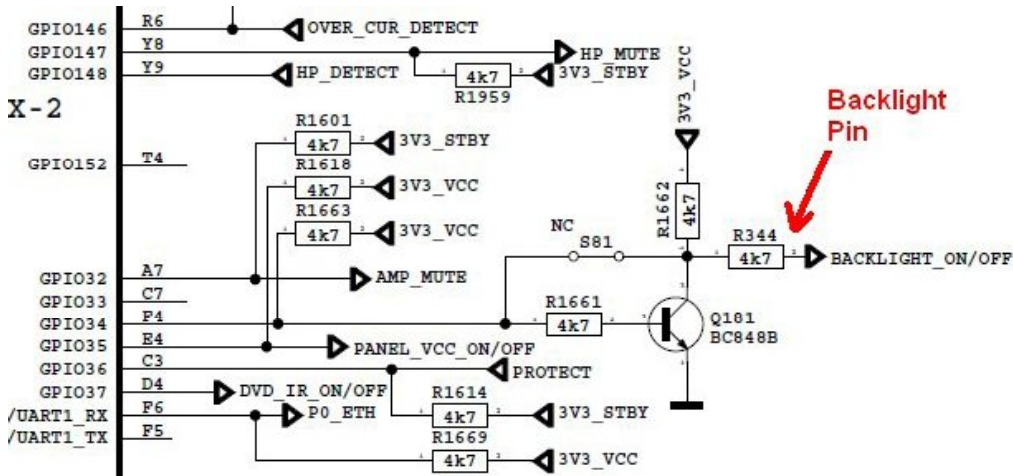

Dimming pin should be high or square wave in open position. If it is low, please check S16 for Mstar side and panel or power cables, connectors.

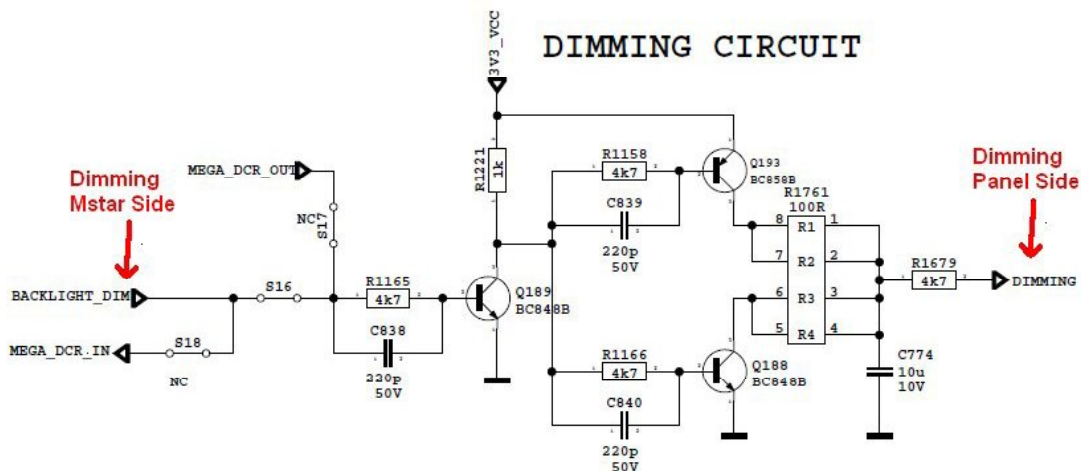

Backlight power supply should be in panel specs. Please check CN705 for MB60, related connectors for power supply cards.

## INVERTER SOCKET W/ADAPTER

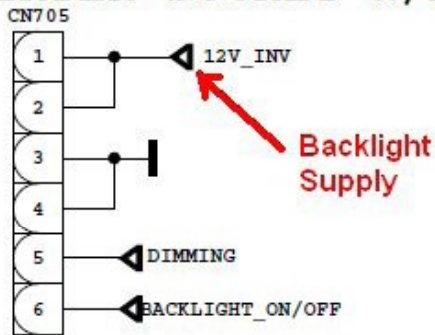

STBY\_ON/OFF should be low for standby on condition, please check R1677.

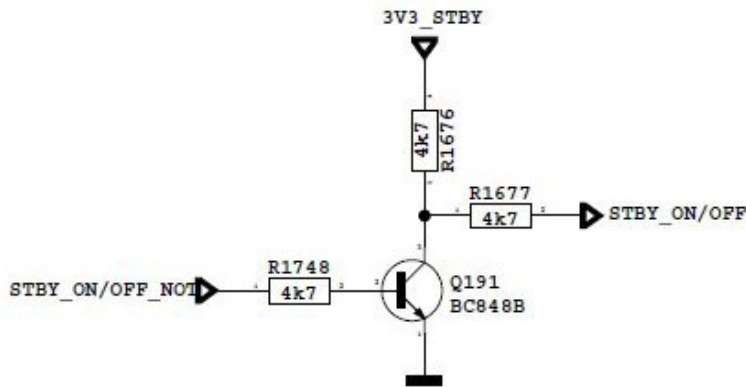

### 23.2. CI Module Problem

Problem: CI is not working when CI module inserted.

Possible causes: Supply, supply control pin, detect pins, mechanical positions of pins  
 CI supply should be 5V when CI module inserted. If it is not 5V please check  
 CI\_POWER\_CTRL, this pin should be low.

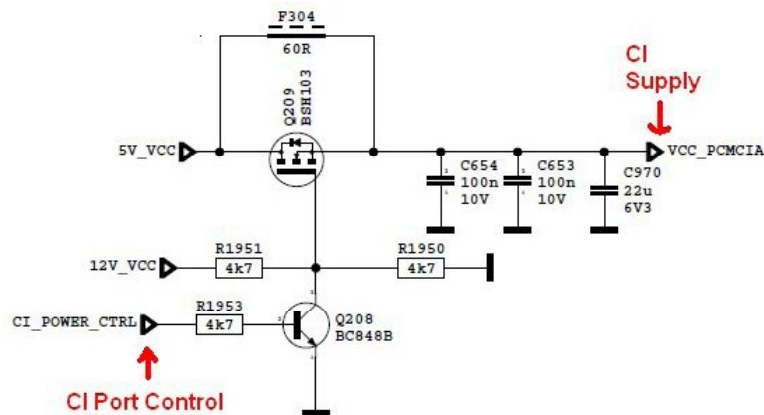

Please check mechanical positions of CI module.

Detect ports should be low. If it is not low please check CI connector pins, CI module pins and 3V3\_VCC on MB60.

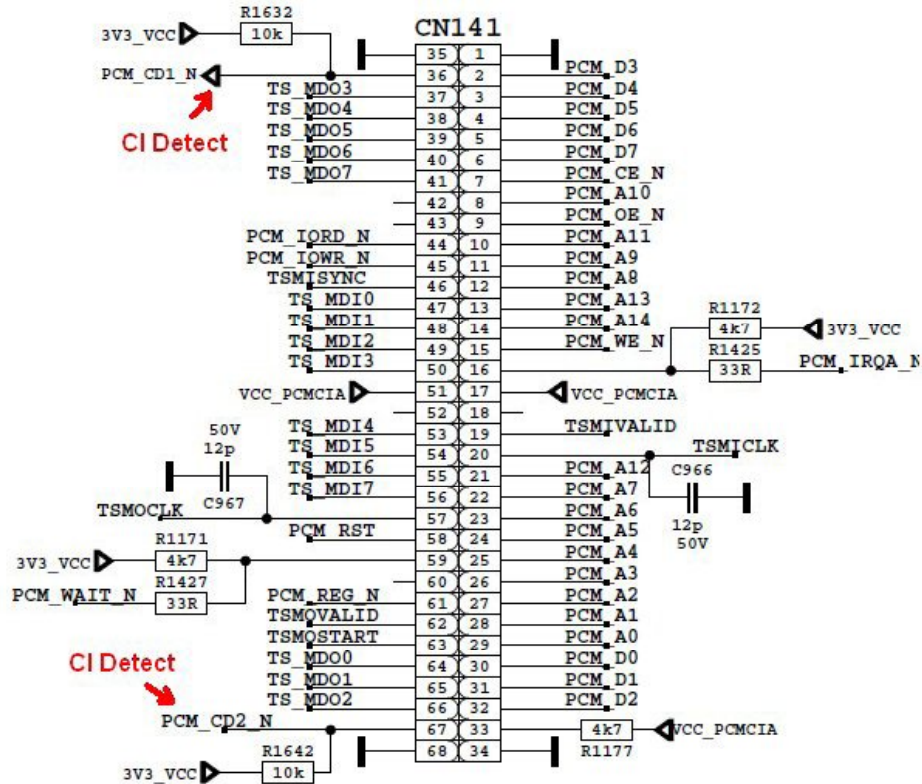

### 23.3. Led Blinking Problem

Problem: LED blinking, no other operation

This problem indicates a short on Vcc voltages. Protect pin should be logic high while normal operation. When there is a short circuit protect pin will be logic low. If you detect logic low on protect pin, unplug the TV set and control voltage points with a multimeter to find the shorted voltage to ground.

#### SHORT CCT PROTECTION

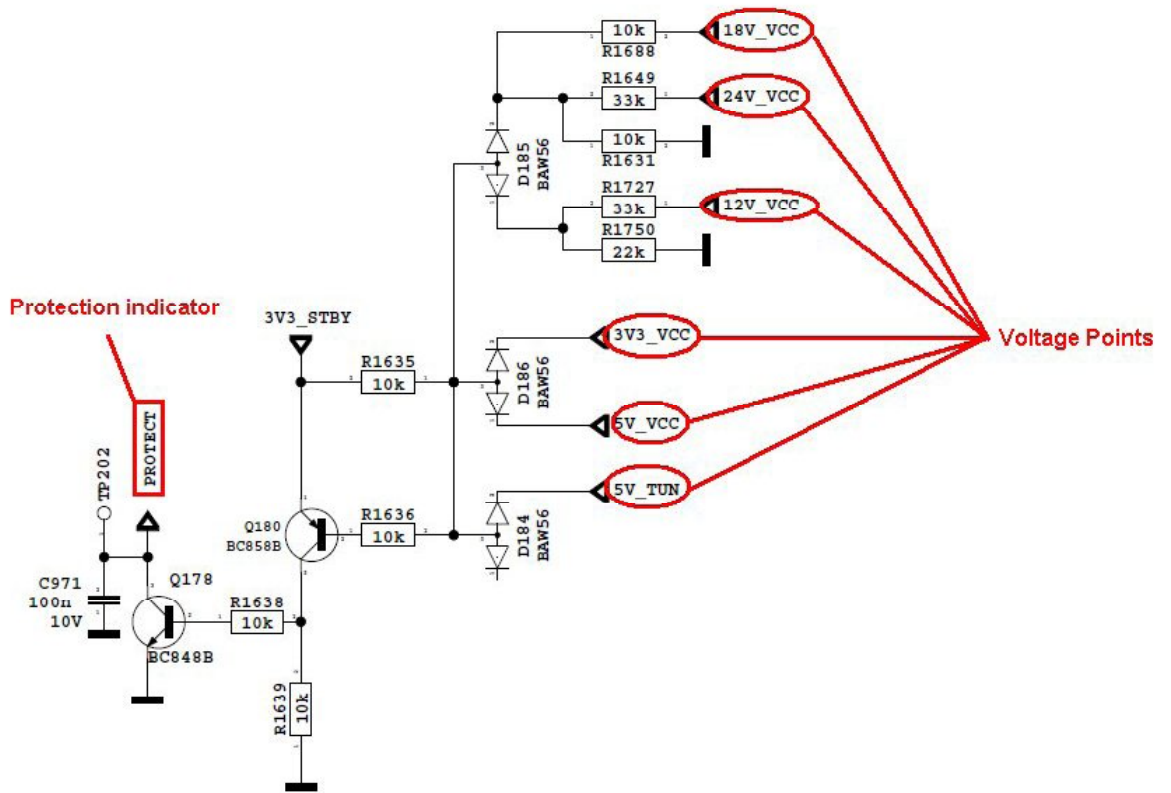

### 23.4. IR Problem

Problem: LED or IR not working  
Check LED card supply on MB60 chasis.

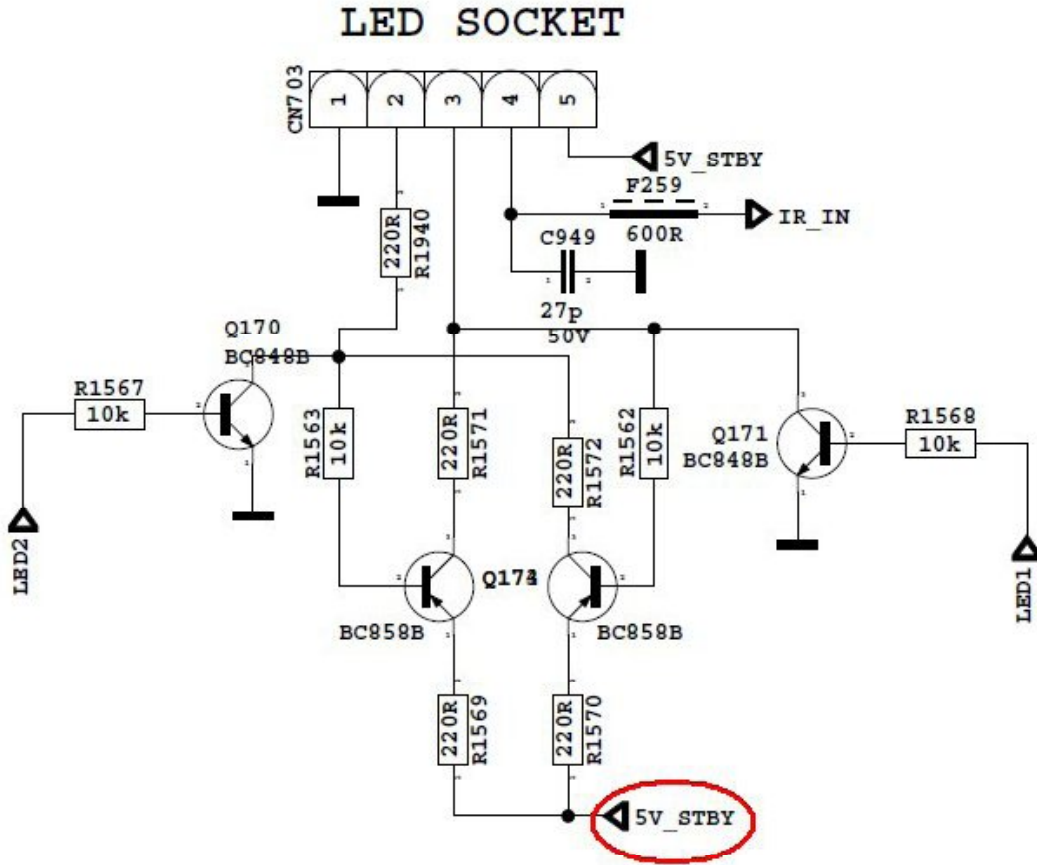

### 23.5. Keypad Touchpad Problems

Problem: Keypad or Touchpad is not working

Check keypad supply and KEYBOARD pin on MB60.



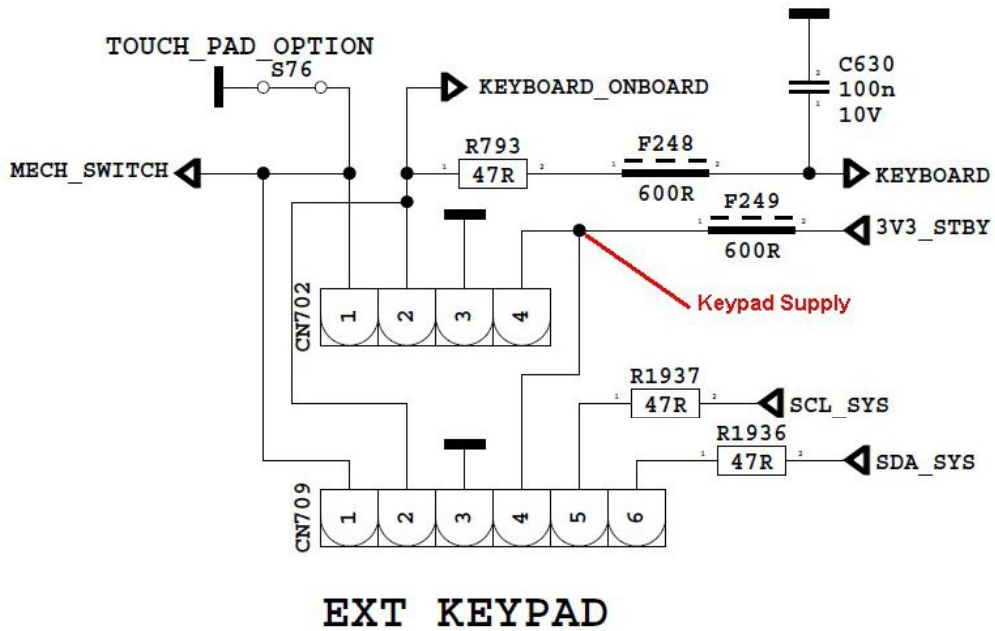

### 23.6. USB Problems

Problem: USB is not working or no USB Detection.

Check USB Supply, It should be nearly 5V. Also USB Enable should be logic high.

## USB INTERFACE

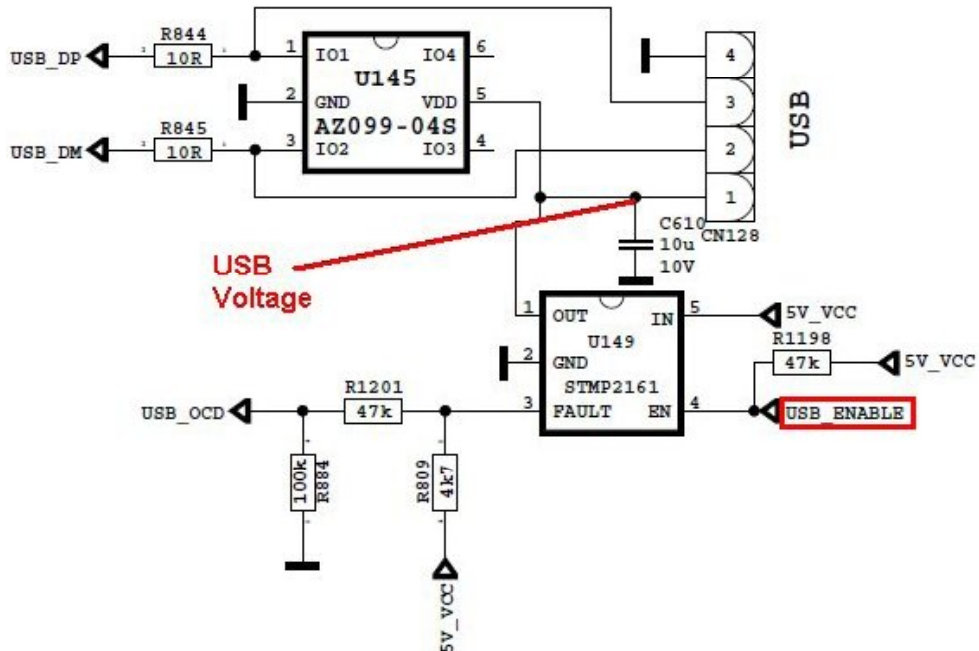

### 23.7. No Sound Problem

Problem: No audio at main TV speaker outputs.

Check supply voltages of VDD\_AUDIO, 5V\_VCC and 3V3\_VCC with a voltage-meter. There may be a problem in headphone connector or headphone detect circuit (when headphone is connected, speakers are automatically muted). Measure voltage at HP\_DETECT pin, it should be 3.3v.

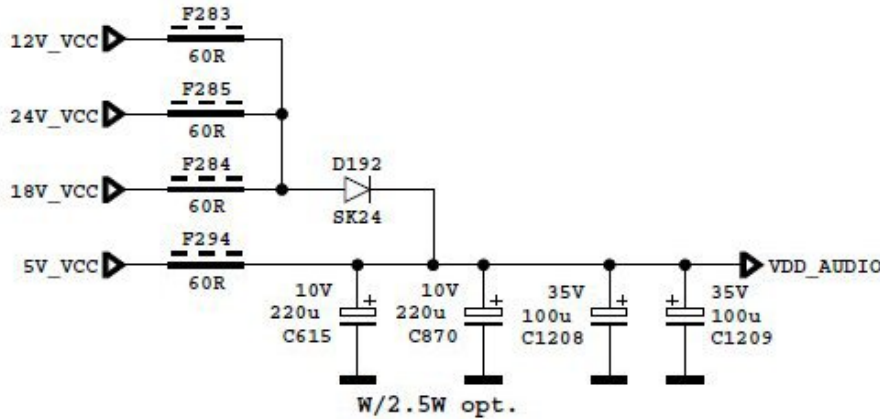

### 23.8. No Sound Problem at Headphone

Problem: No audio at headphone output.

Check HP detect pin, when headphone is. Check 5V\_VCC and 3V3\_VCC with a voltage-meter.

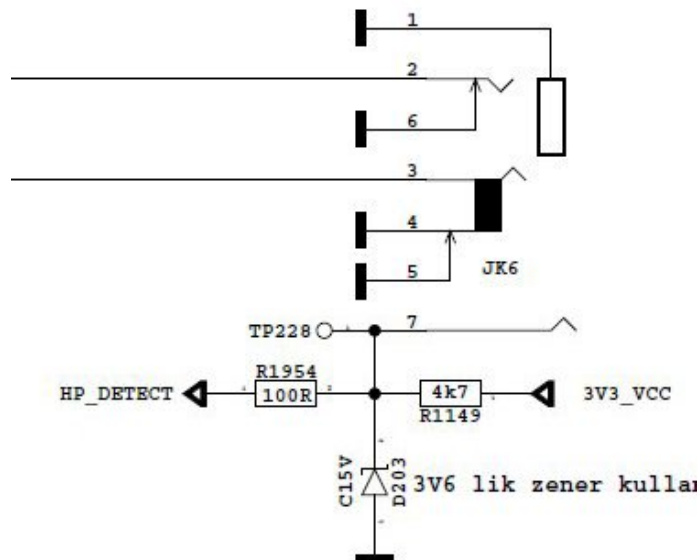

### 23.9. Standby On/Off Problem

Problem:

Device cannot boot, TV hangs in standby mode.

There may be a problem about power supply. Check 12V\_VCC, 5V\_VCC and 3V3\_VCC with a voltage-meter. Also there may be a problem about SW. Try to update TV with latest SW. Additionally it is good to check SW printouts via hyper-terminal (or Teraterm). These printouts may give a clue about the problem.

### DVD Problems

Problem: DVD is not working.

Check that DVD source is selected in Service menu. Check supply voltage of DVD namely 12V\_VCC.

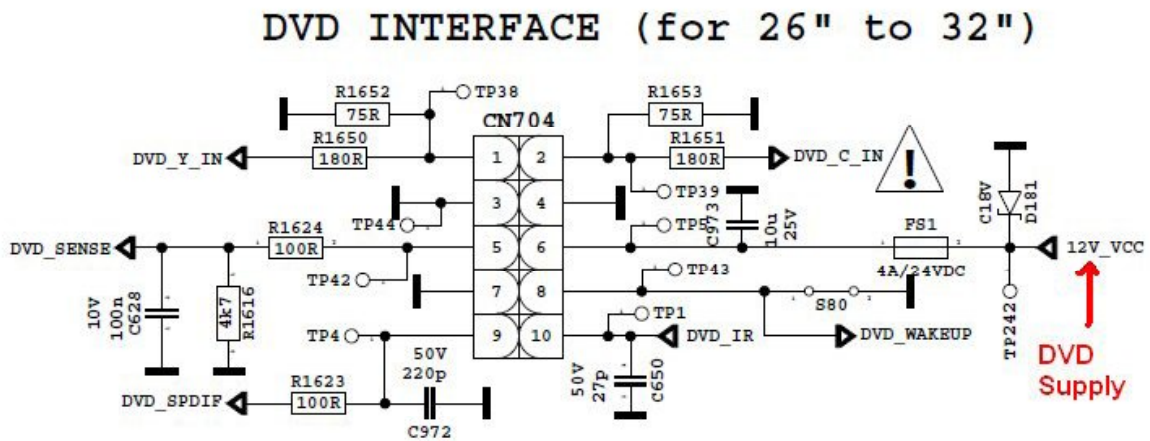

### 23.10. No Signal Problem

Problem: No signal in TV mode.

Check tuner supply voltage; 5V\_TUN. Check tuner options are correctly set in Service menu. Check AGC voltage at RF\_AGC pin of tuner.

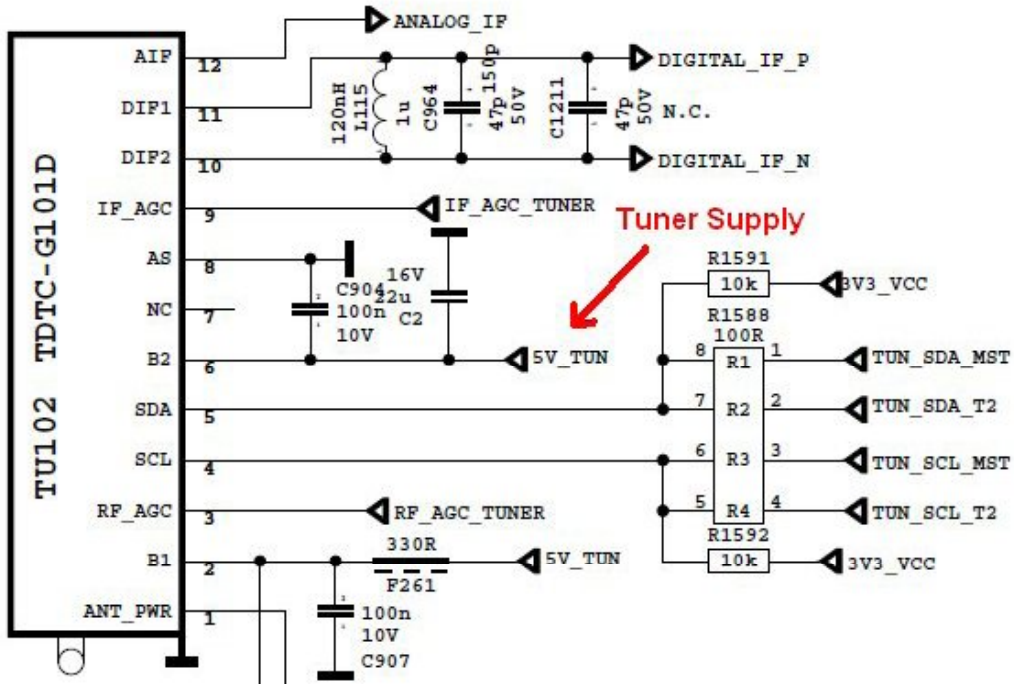

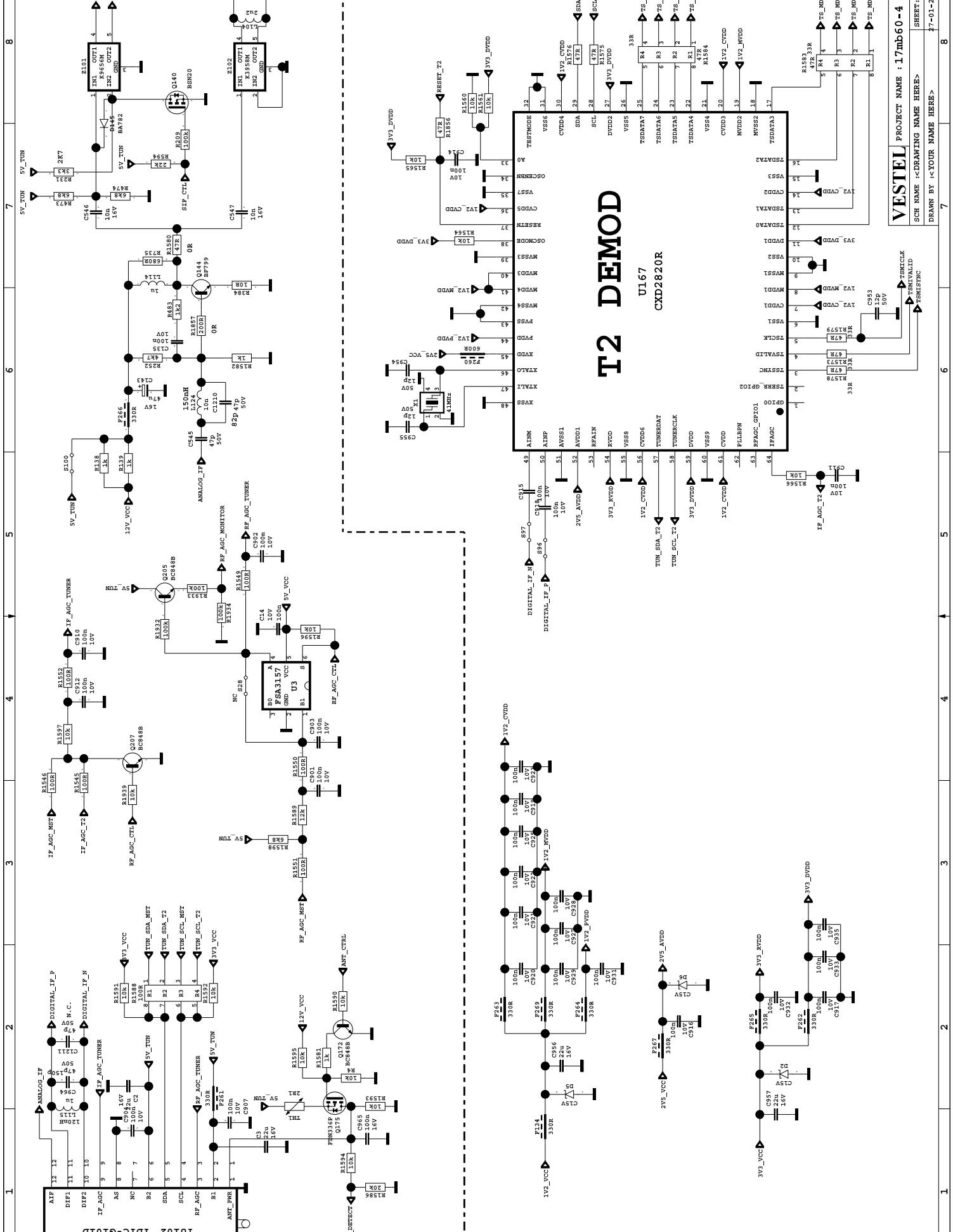

# T2 DEMOD

U167  
CXD2820R

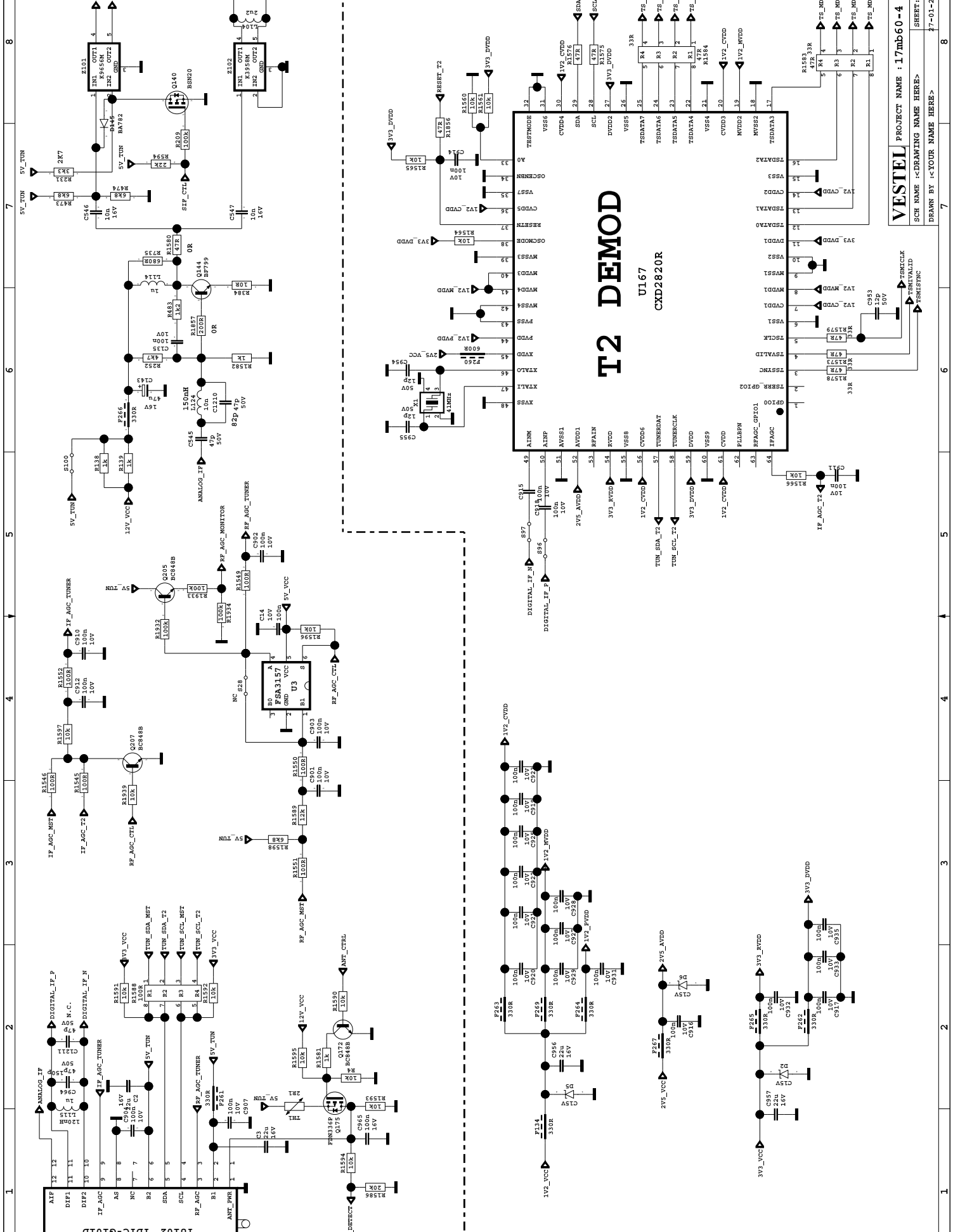

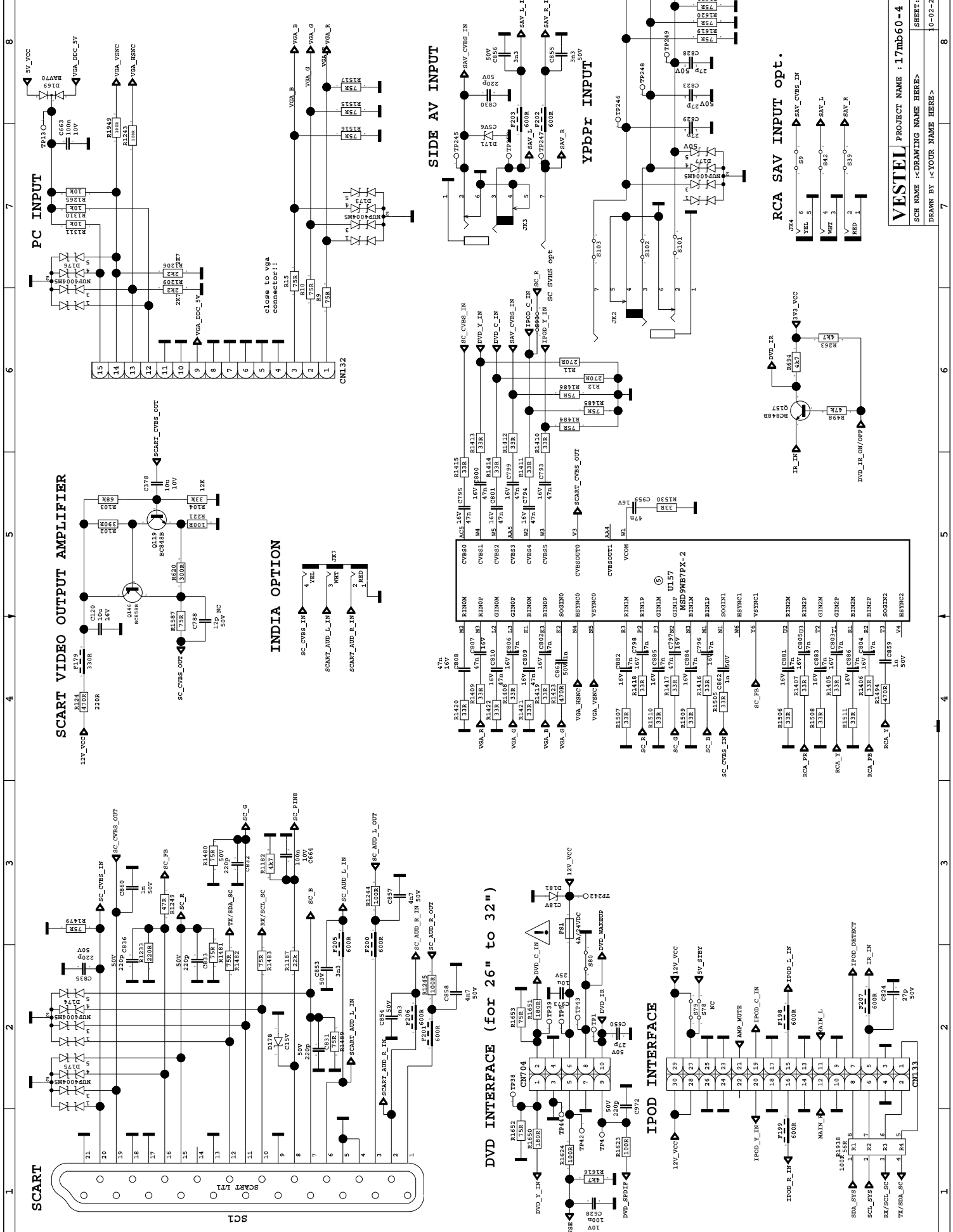

1 2 3 4 5 6 7 8

A B C D E F

SCART VIDEO OUTPUT AMPLIFIER

SCART AV INPUT

PC INPUT

INDIA OPTION

close to vga connector!!

SCART\_CVBS\_OUT

SCART\_AUD\_R\_IN

SCART\_AUD\_L\_IN

SCART\_AUD\_L\_OUT

SCART\_AUD\_R\_OUT

DVD INTERFACE (for 26" to 32")

IPOD INTERFACE

RCA SAV INPUT opt.

SCART\_CVBS\_IN

SCART\_AUD\_L\_IN

SCART\_AUD\_R\_IN

SCART\_AUD\_L\_OUT

SCART\_AUD\_R\_OUT

DVD\_CVBS\_IN

DVD\_CIN

DVD\_CIN

DVD\_CIN

DVD\_CIN

DVD\_CIN

DVD\_CIN

DVD\_CIN

DVD\_CIN

DVD\_CIN

DVD\_CIN

DVD\_CIN

DVD\_CIN

DVD\_CIN

DVD\_CIN

DVD\_CIN

DVD\_CIN

DVD\_CIN

DVD\_CIN

DVD\_CIN

DVD\_CIN

DVD\_CIN

DVD\_CIN

DVD\_CIN

DVD\_CIN

DVD\_CIN

### ONBOARD KEYBOARD

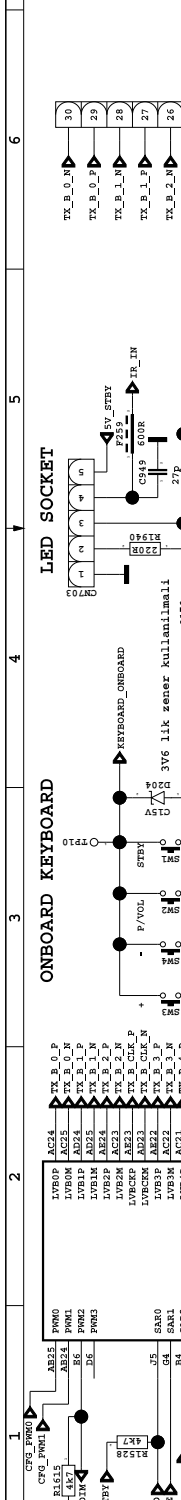

### LED SOCKET

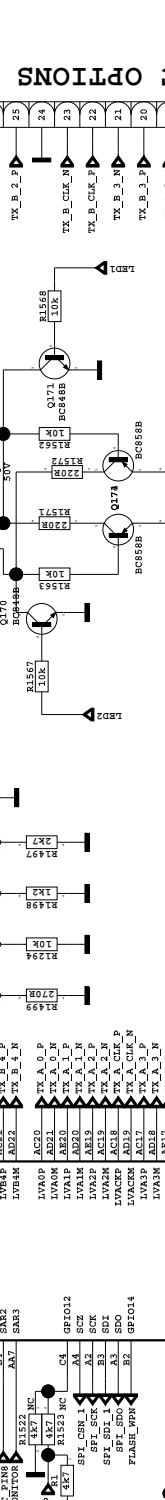

### TOUCH PAD OPTION



### EXT KEYPAD

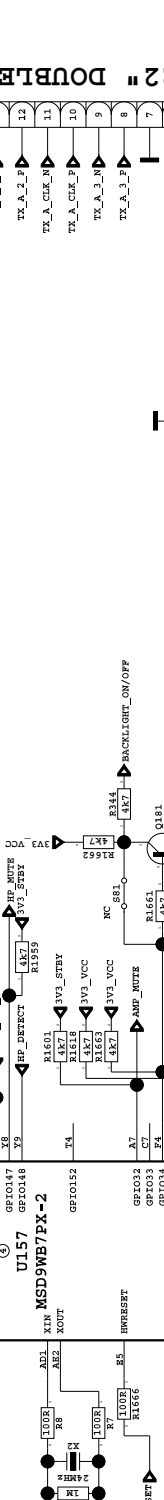

### RESET

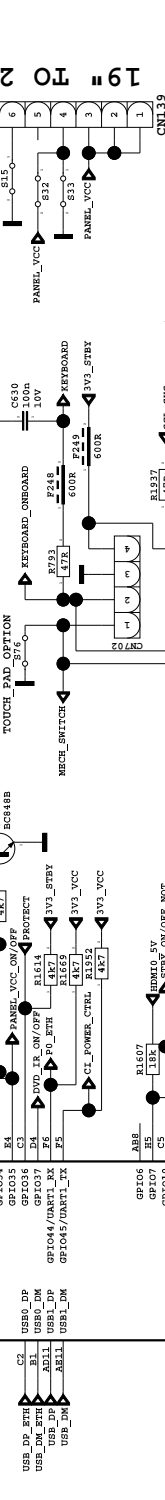

### USB INTERFACE



### DOUBLE LVDS FFC OPTIONS



### SINGLE LVDS FFC OPTIONS



### TWISTED PAIR LVDS OPTION

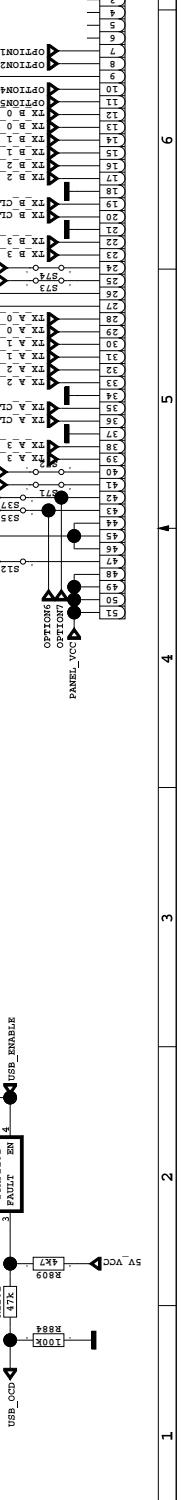

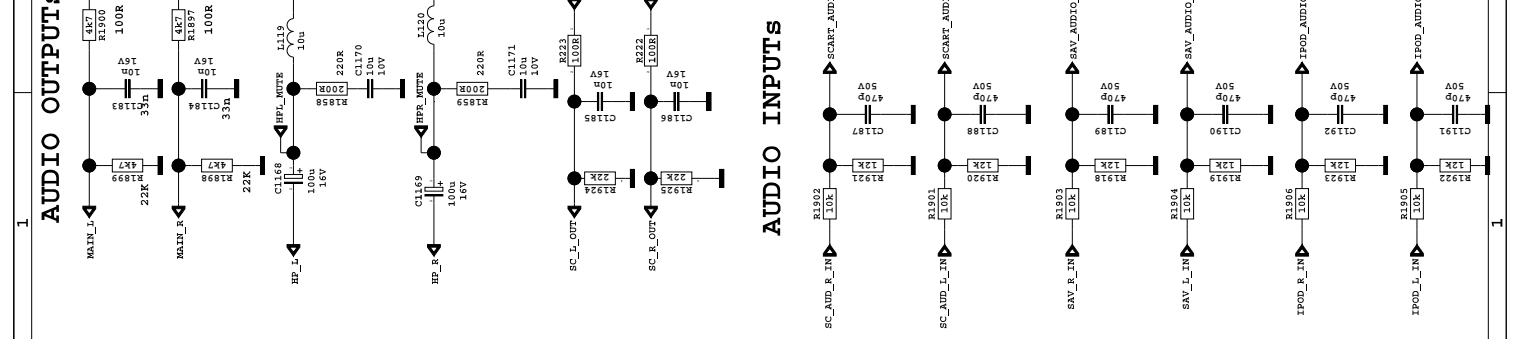
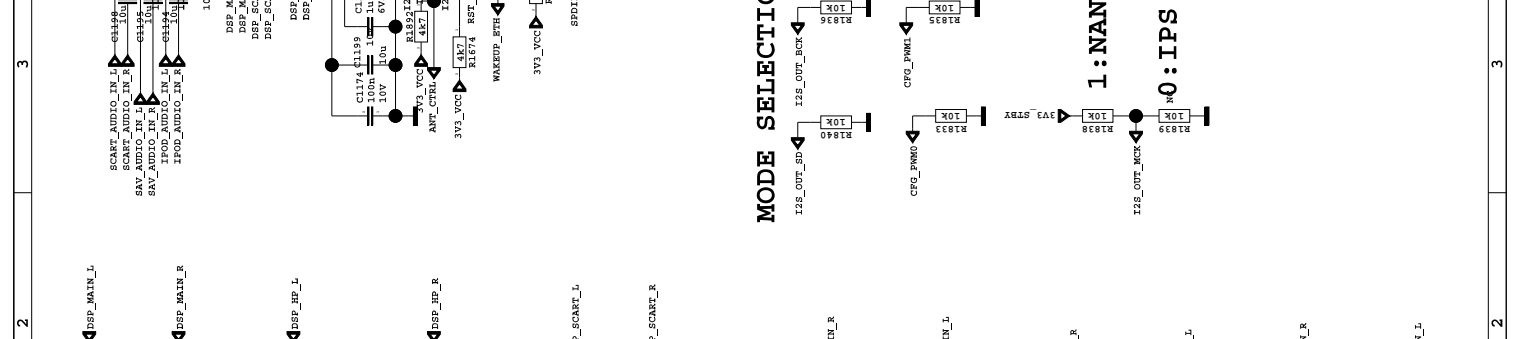
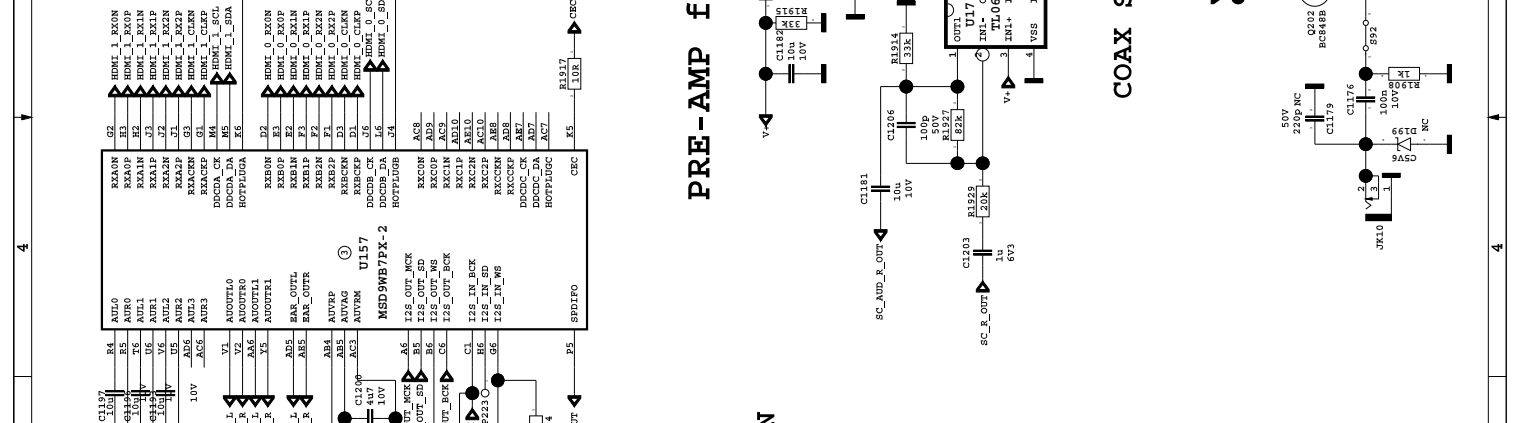
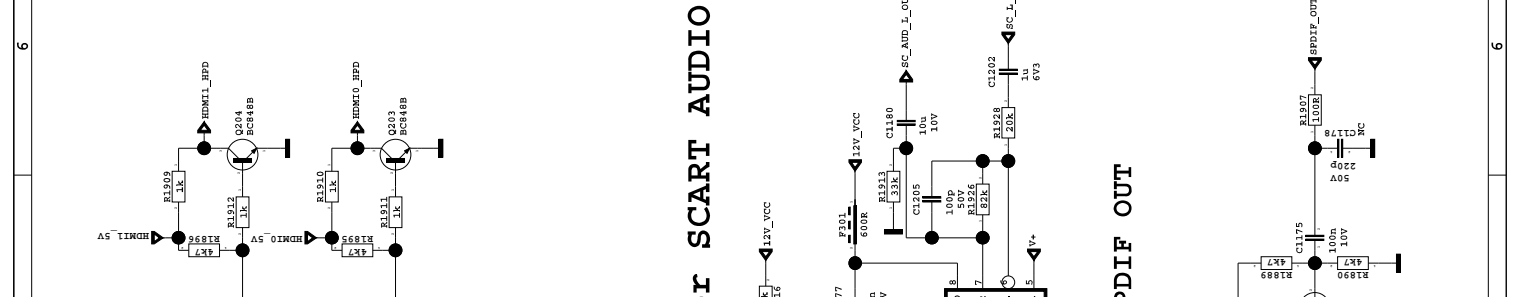
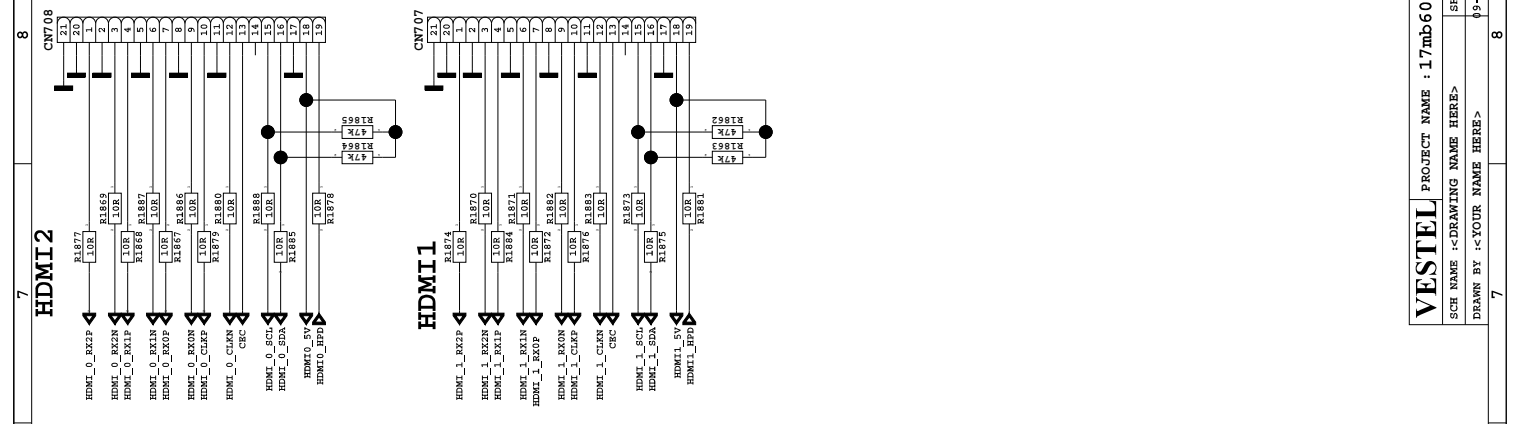

OPTIONAL

COMMON

1 2 3 4 5 6 7 8



# AUDIO AMP for 16" to 24"

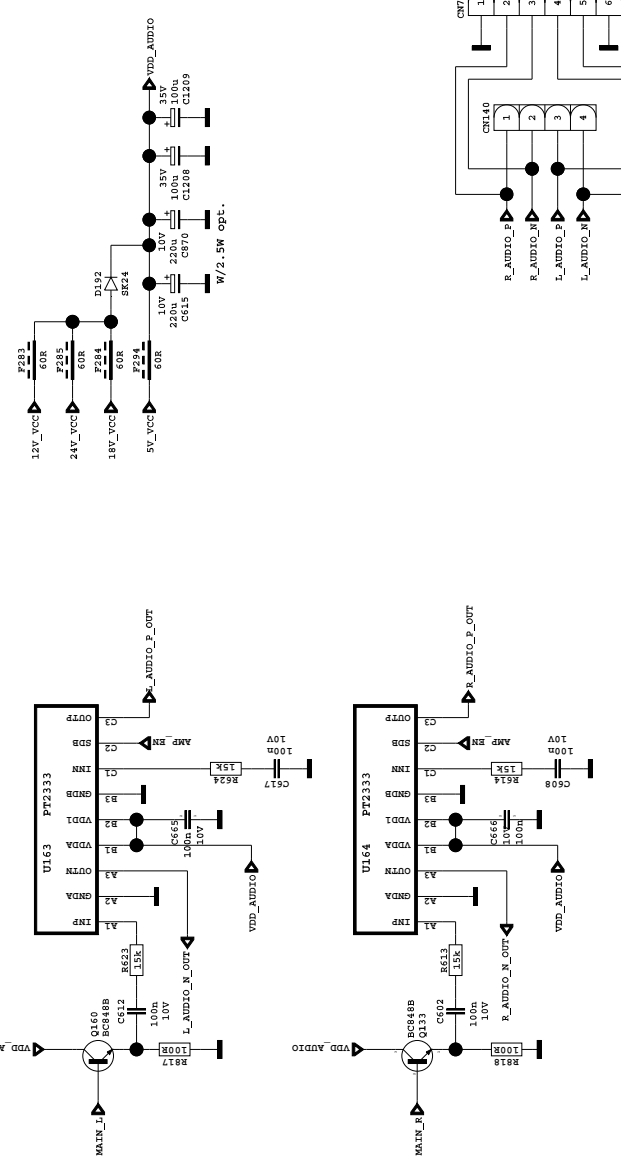

# HEADPHONE OUTPUT

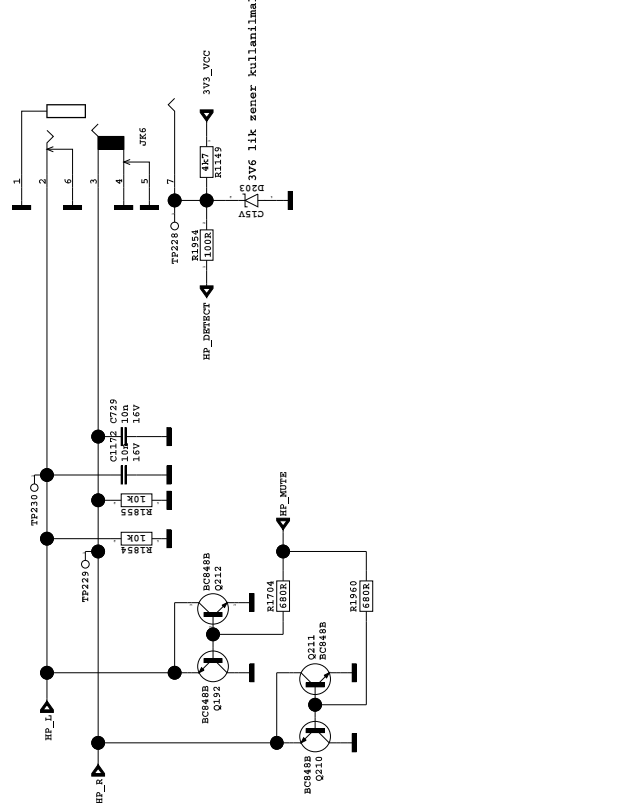

# AUDIO AMP for 26" to 32"

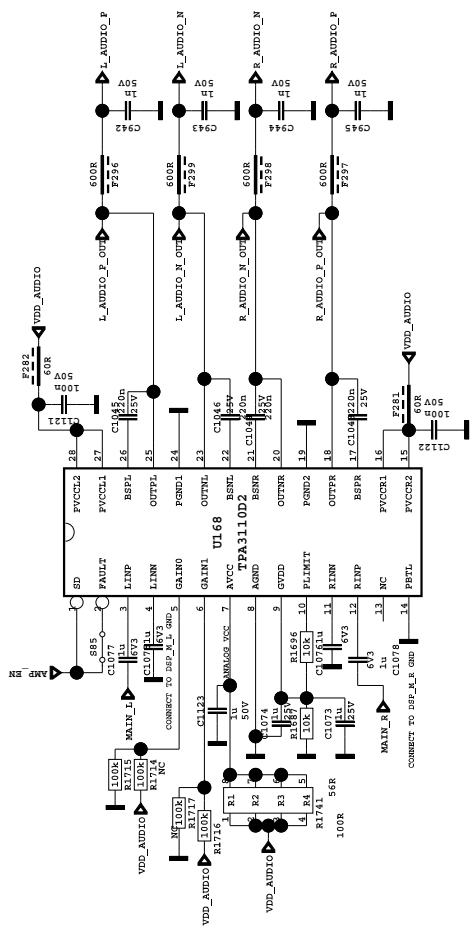

# POP NOISE CIRCUIT

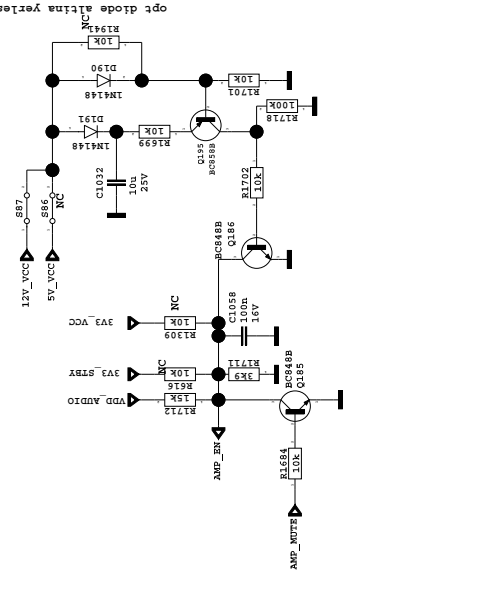

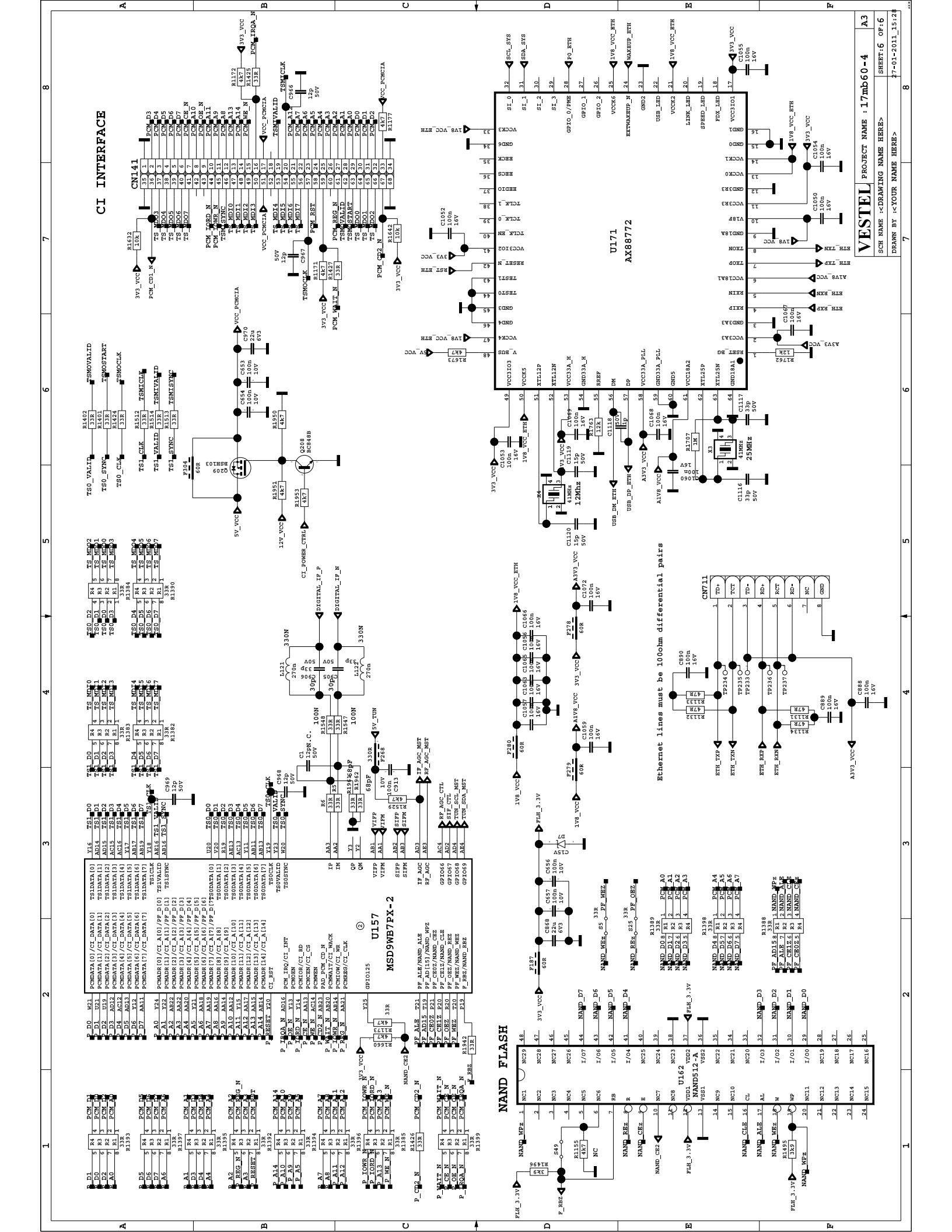

**CI INTERFACE**

PROJECT NAME : 17mb50-4  
SHEET: 6 OF: 6  
DRAWN BY : <DRAWING NAME HERE>  
27-01-2011\_15:28

**NAND FLASH**



**MSD9WB7PX-2**

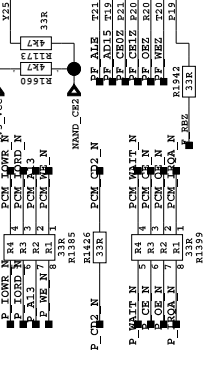

**Ethernet lines must be 100ohm differential pairs**

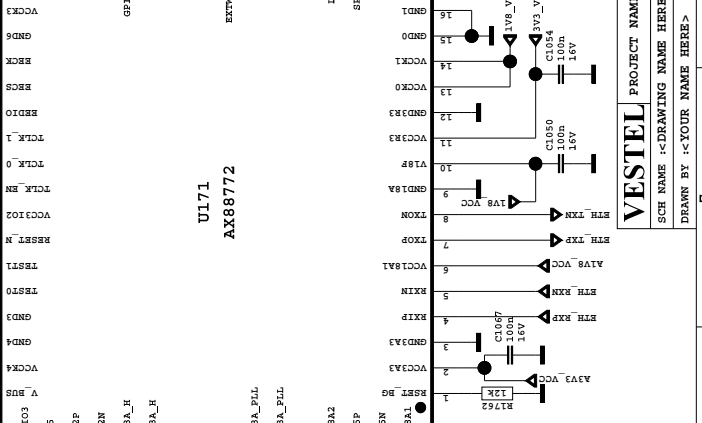
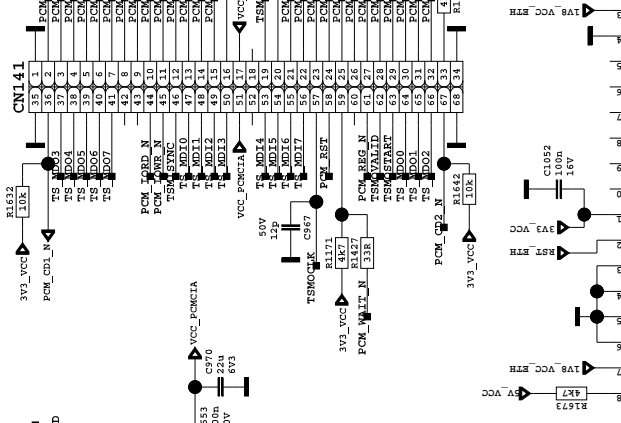
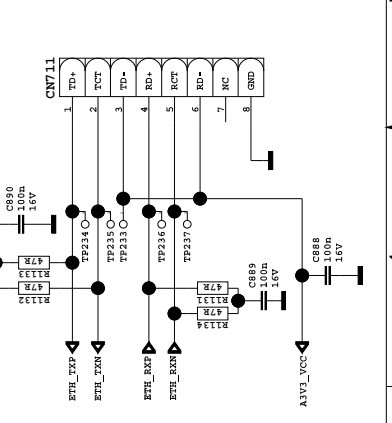

**U157**

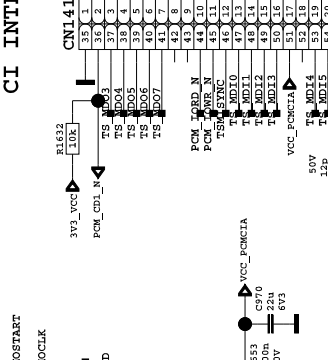

**U171**

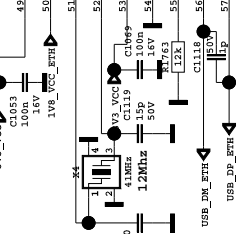
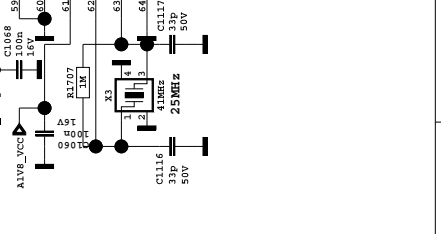
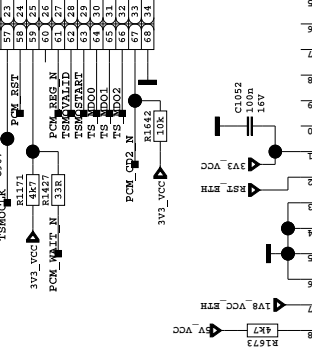

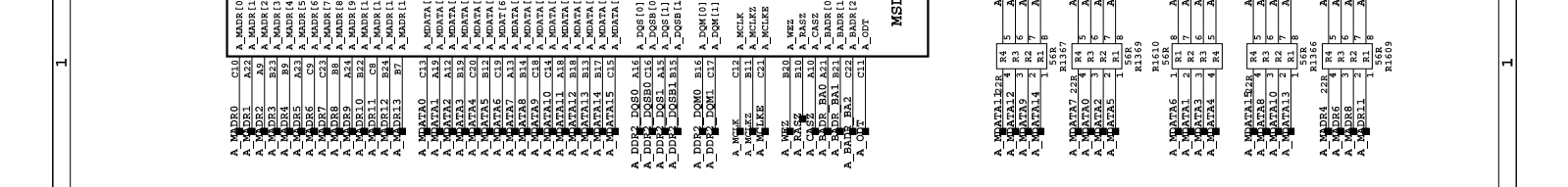
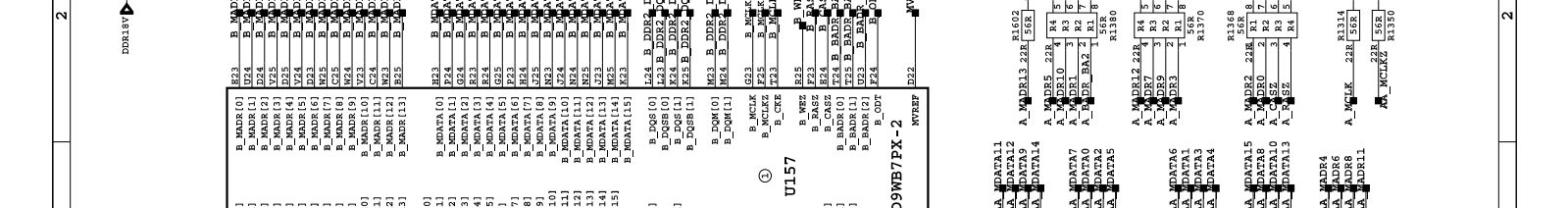
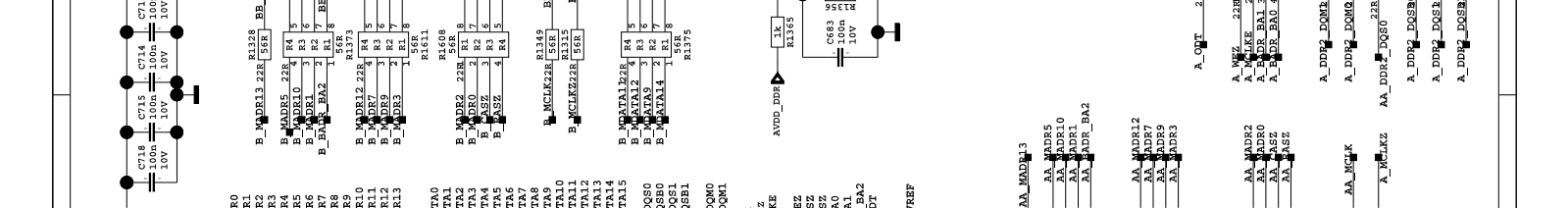
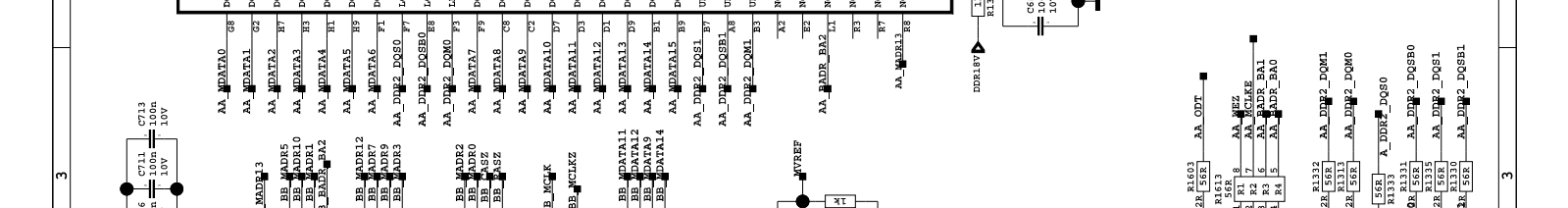
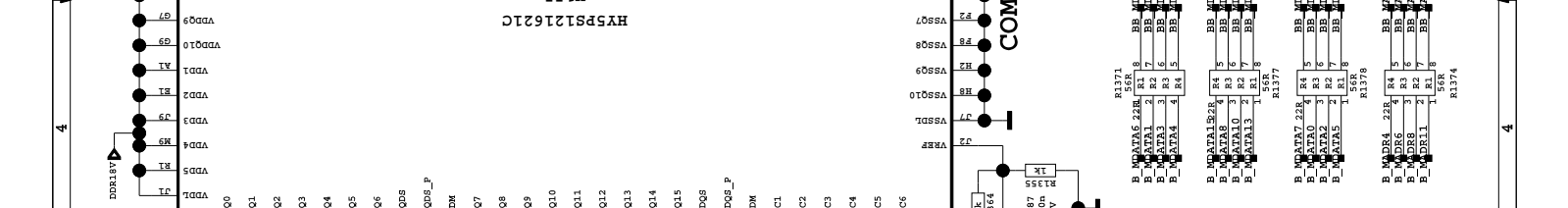
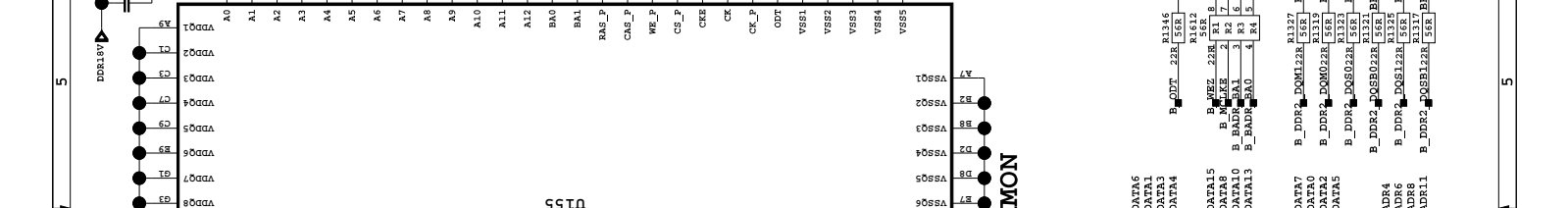
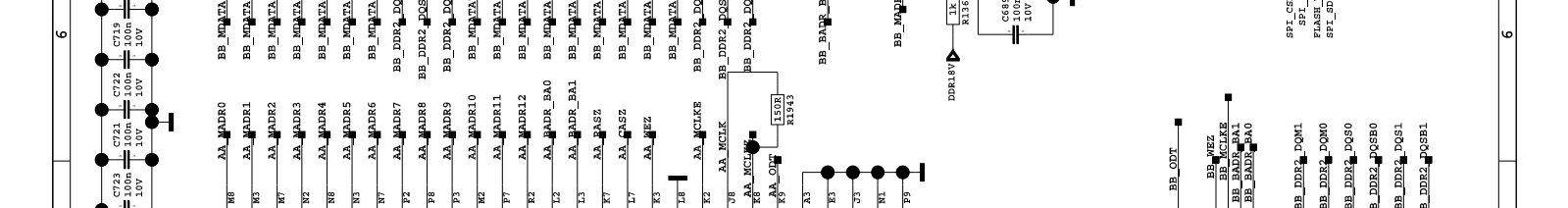
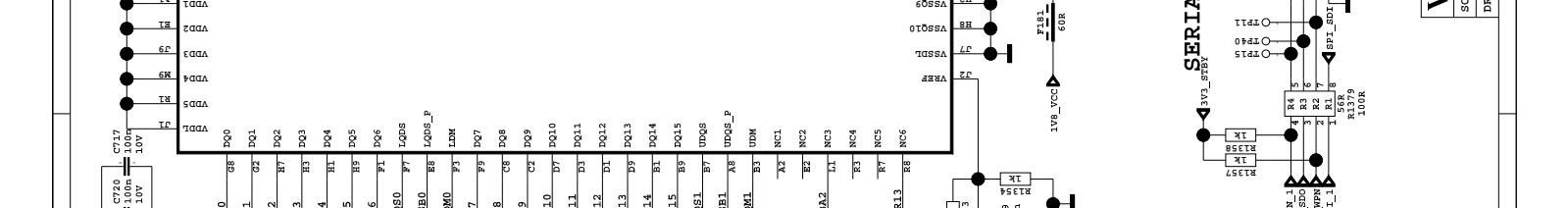
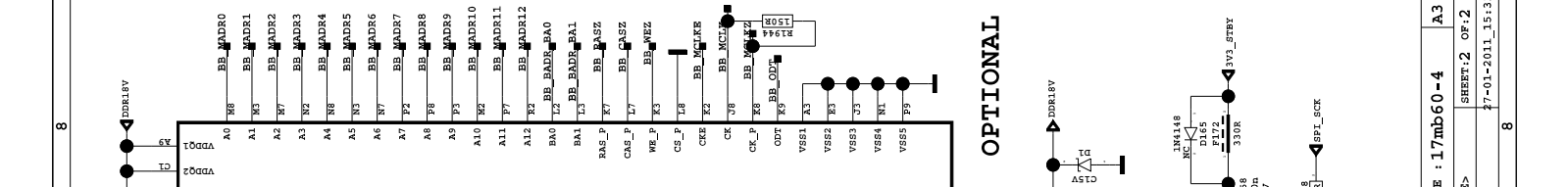
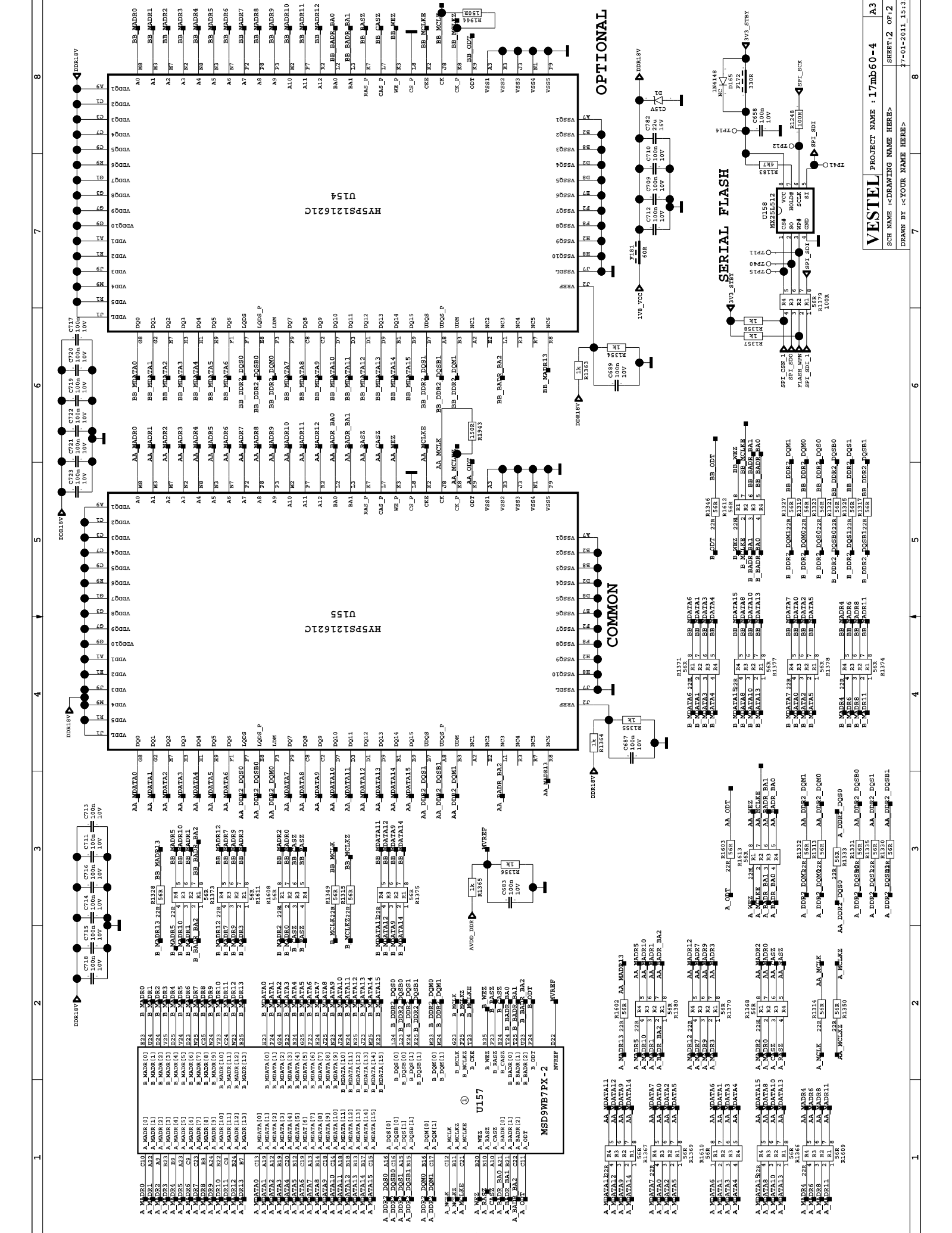

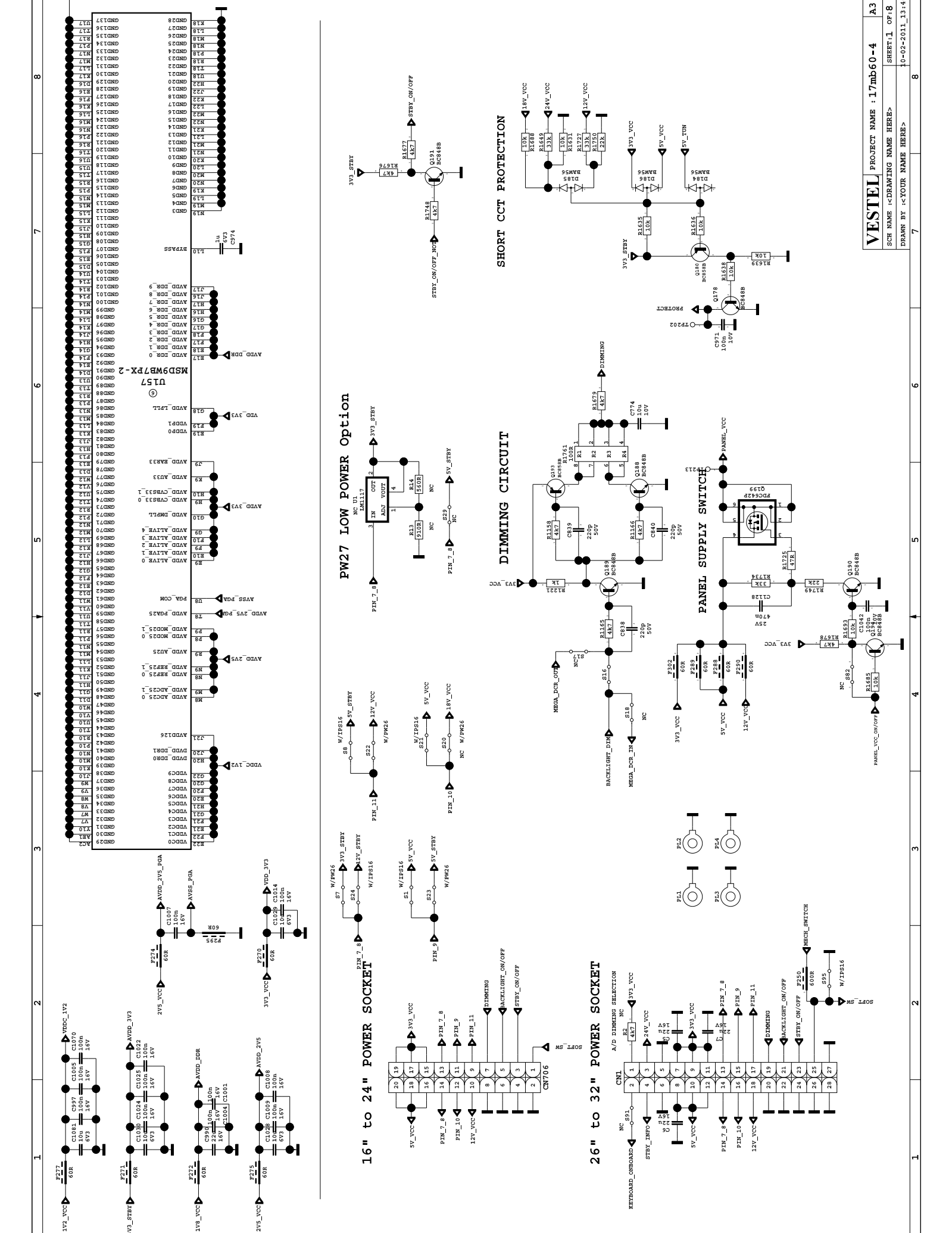

1 2 3 4 5 6 7 8

VESTEL  
 PROJECT NAME : 17mb60-4  
 A3  
 SHEET: 1 OF: 8  
 DRAWN BY : <YOUR NAME HERE>  
 10-02-2011\_13-46

A B C D E F

### ADAPTER SOCKET

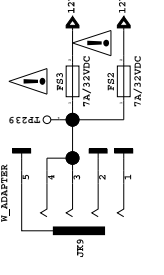

### W/ADAPTOR

### POWER BLOCK DIAGRAM

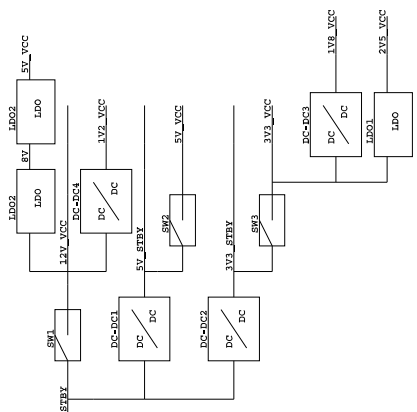

### INVERTER SOCKET W/ADAPTER

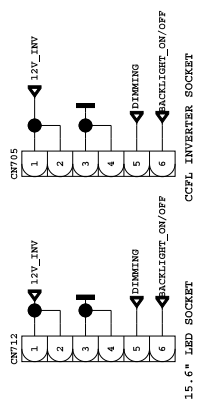

## W/ADAPTOR & W/IPS16&17&60

### SW1

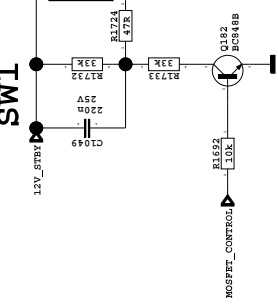

### DC/DC2

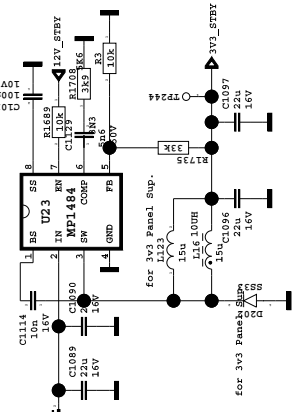

### SW3

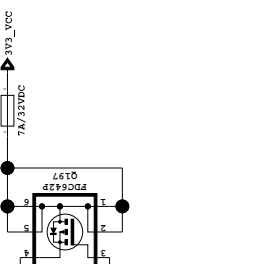

## COMMON

### LDO1

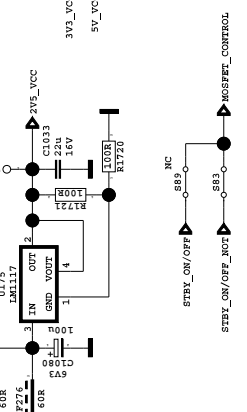

### DC/DC3

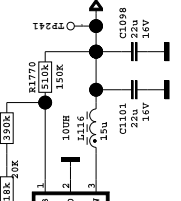

### DC/DC4

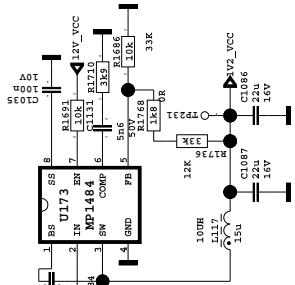

### LDO 2

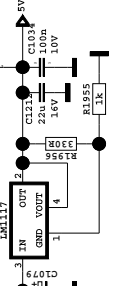

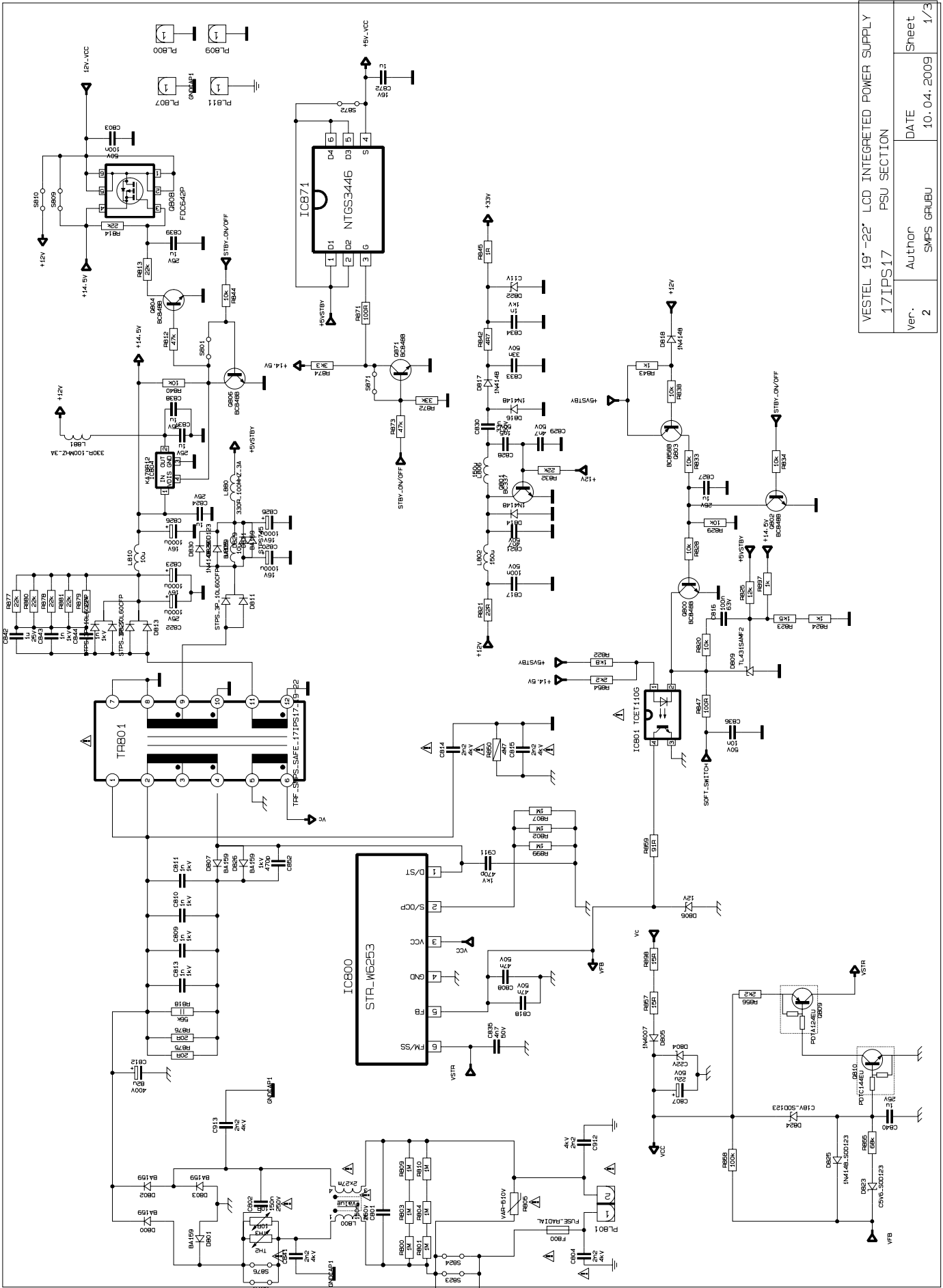

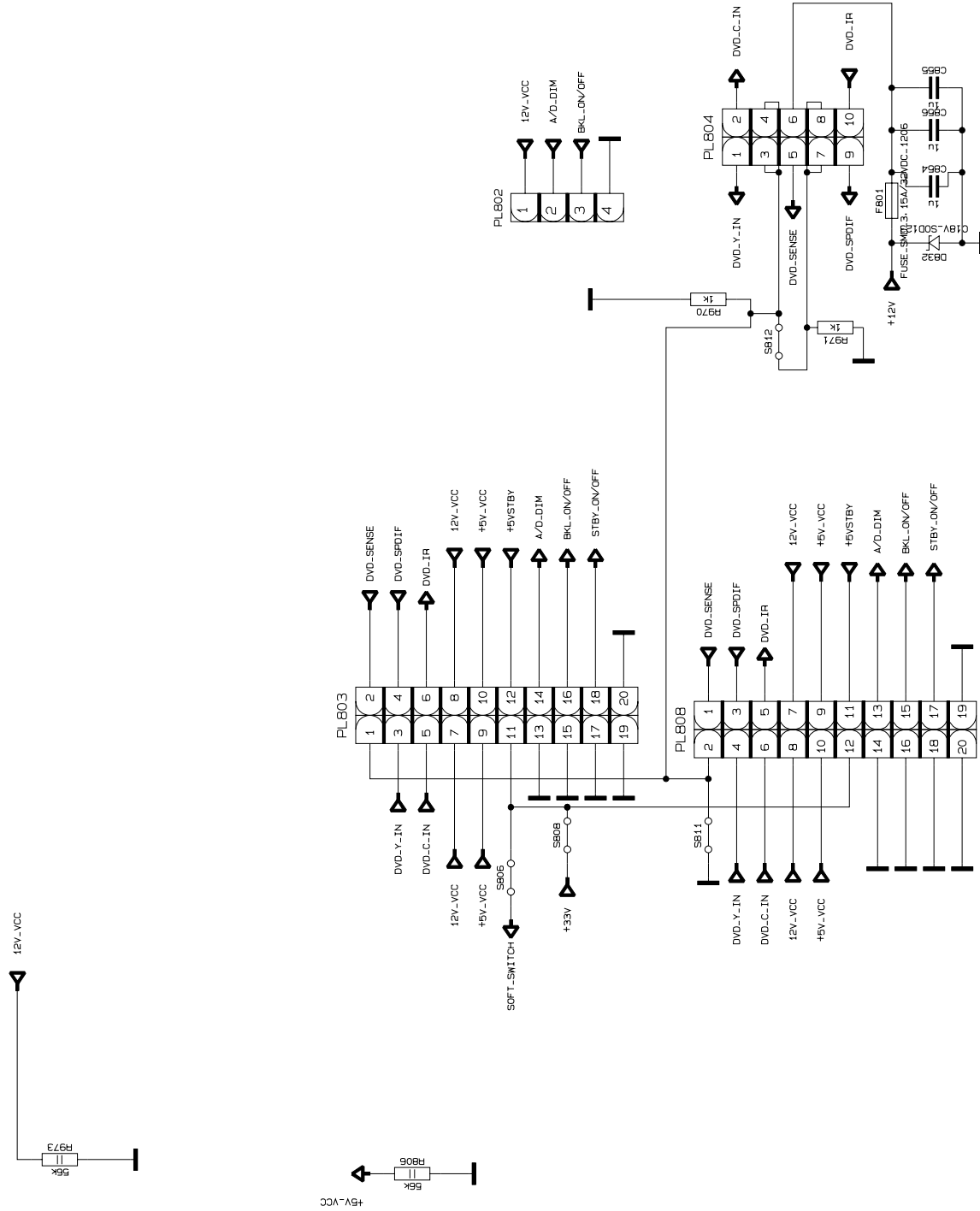

VESTEL 19" -22" LCD INTEGRATED POWER SUPPLY  
17IPS17 CONNECTOR SECTION

Ver.	Author	DATE	Sheet
00	SMPS GRUBU	10. 04. 2009	3/3

LCD 19008 MB 25 DVD		VESTEL KOD	
MATERIAL:	FILE: Makamlik V1 Vars (reembi..._adil.dwg)	SHEET:	1/1
DRAFT: HASAN SARAF	DATE: 12.07.2010	SCALE:	1/1
DESIGN: BASAR MUSTEAPLOGLU	UNIT		
CHECK: DENIZ CETINTUREK	mm		
APPR.: SEYIT KARAG.NEY			
<b>VESTEL</b> ELEKTRONİK SAN. VE TİC. A.Ş. MANİSA/T. PKIYE TEL: +90.236.2330131 FAX: +90.236.2333668 PAPER SIZE A0			

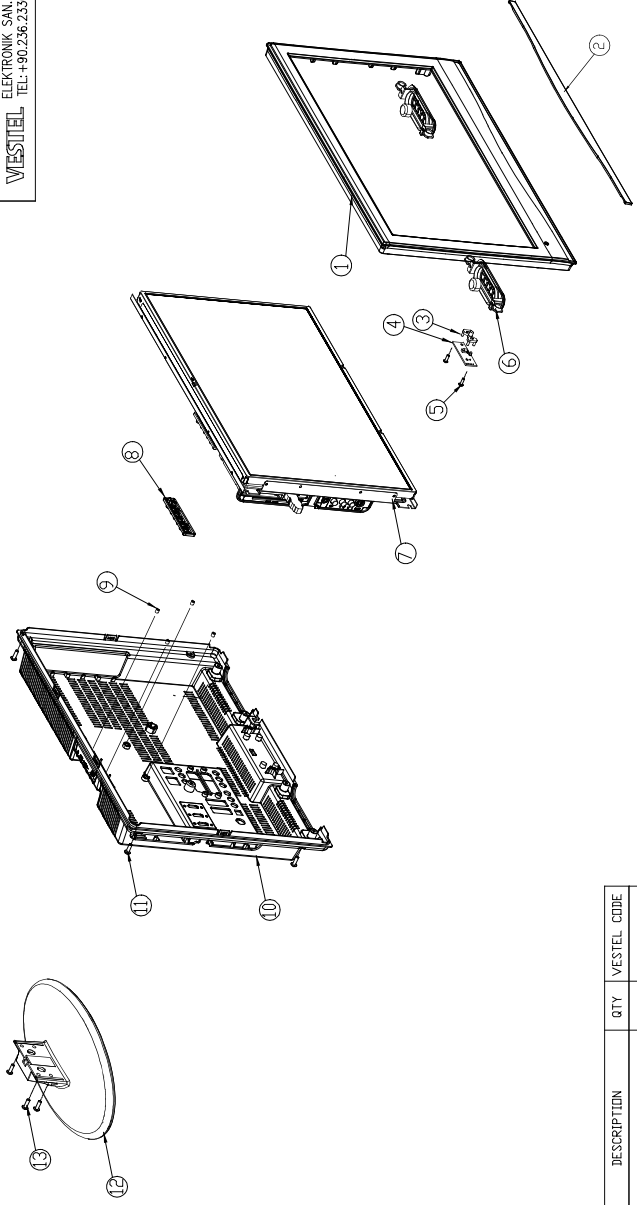

NO	DESCRIPTION	QTY	VESTEL CODE
1	FRONT COVER LCD 19008	1	
2	COSMETIC LENS 19008	1	
3	LENS IR x866	1	20400623
4	L7 LD 98	1	20403610
5	SCREW P C ZN YFMB 3 x 9.5	2	35006081
6	ASM SPEAKER	2	
7	19\"/>		



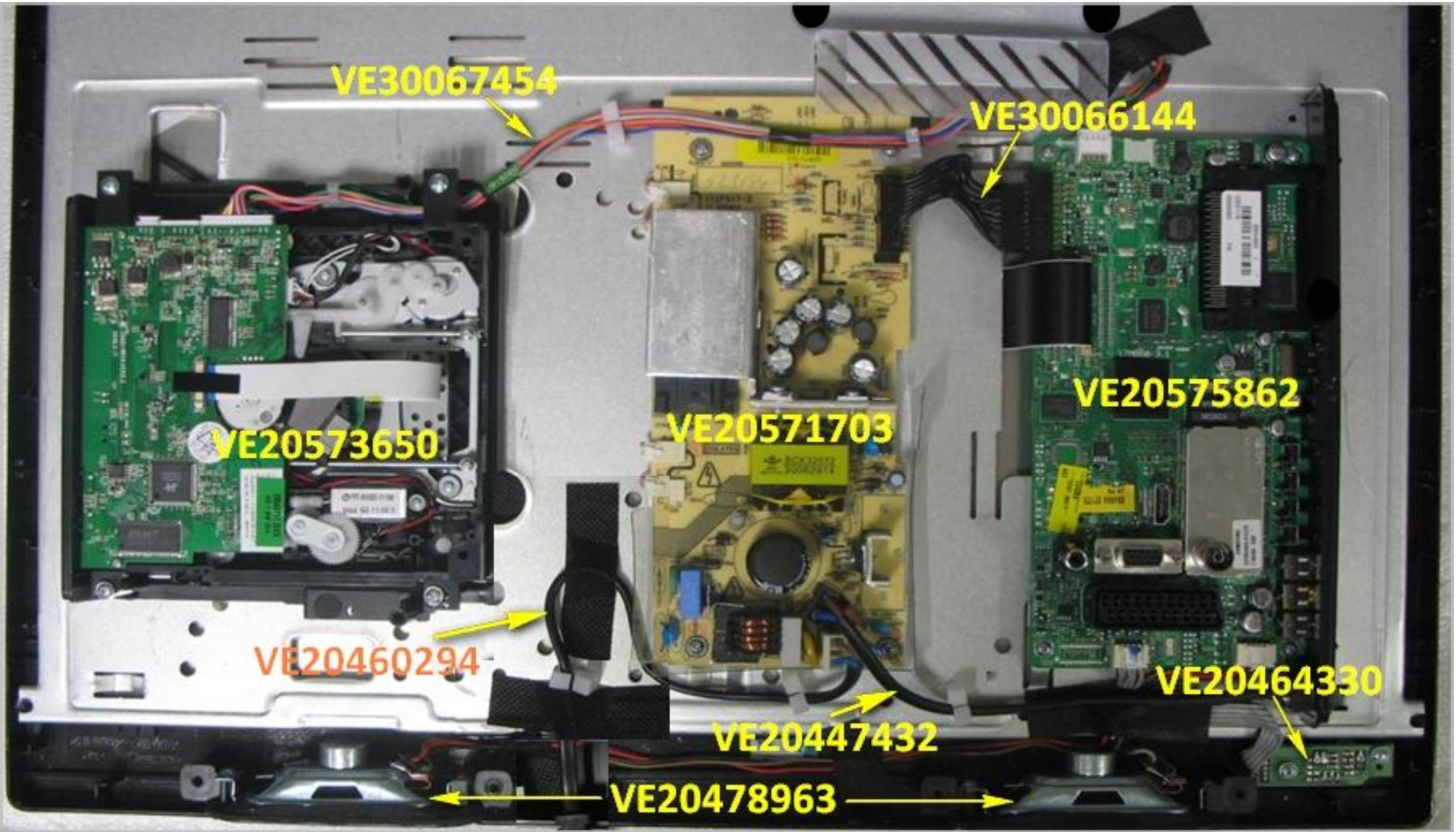

VE30067454

VE30066144

VE20573650

VE20571703

VE20575862

VE20460294

VE20464330

VE20447432

VE20478963

# PARTS EXPLANATION

PART NUMBER	DESCRIPTION	QUANTITY
VE20554540	BACK COVER 22855(16/9)DVD	1
VE20575862	CHS.ASSY.17MB60-C4K12315372221115B1	1
VE20570013	REMOTE CONTROLLER	1
VE20516175	FRONT CABINET 22908(16/9)	1
VE20478963	SPEAKERS	1
VE20571703	MD.ASY.17IPS17-22"(CAB(60(ROC(AVUSTRALYA	1
VE20460294	POWER CORD	1
VE30064829	TFT LCD 216W LG LC220WXE TBA1 RoHS	1
VE40044328	LENS COSM.LCD22908-SILVER BR.HST	1
VE40043424	LED IR LENS TFT XX856 (%3 MILKY) VER6.	1
VE20464330	MD.ASY.17LD98-7-19-22841 (MB25/45)	1
VE20447432	ROCKER SWITCH ASY.	1
VE20573650	HCN(LC) DL08 DVD G1-WO/USBMMC SW-REG4 YC	1
VE30067454	CNAS12P+10P/410 SHL W/DC+F UL2464#26ROHS	1
VE30066144	CNAS 20P/60 SIS W/DC UL1007 AWG24 RoHS	1
VE20464600	CN.A.FFC 30P/300 P=1MM LVDS(2287545LG	1
VE30067738	CNAS 2P/200 SIS UL3239 AWG22 W/LOCK ROHS	4

1. VE 20554540 BACK COVER 22908 W/DVD
2. VE20575862 MAIN BOARD (MB60 CHASSIS)
3. VE20570013 REMOTE CONTROLLER
4. VE20516175 FRONT CABINET 22908
5. VE20478963 SPEAKERS KIT
6. VE20571703 POWER SUPPLY BOARD (IPS17 BOARD)
7. VE20460294 POWER CORD & PLUG
8. VE40044328 COSMETICAL LENS // Apply it on to the front cabinet



9. VE30064829

21.6" TFT LCD DISPLAY (PANEL)

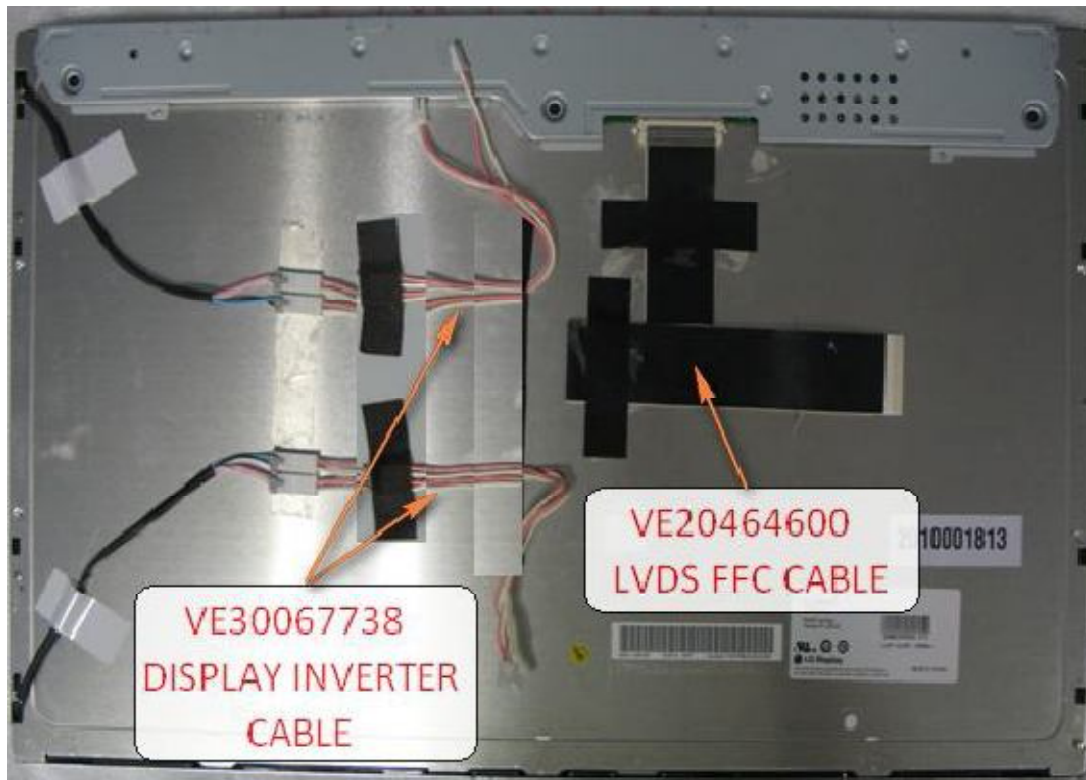

10. VE40043424

LED IR LENS



11. VE20464330

LED/IR BOARD // this code also includes the cable, which is between LED/IR board and main board. Fix it into CN703 position on the MB60 chassis.

12. VE20447432

ROCKER SWITCH CABLE // Fix it to PL815 position on the IPS17 board

13. VE20573650

DVD LOADER

14. VE30067454

DVD CABLE // It's the cable between main board and DVD loader. Fix it to CN704 position on the MB60 chassis.

15. VE30066144 DC CABLE (PW-MB CABLE) // It's the cable between main board and power board. Fix it to the socket of PL801 position on the IPS17 board and the socket of CN706 position on the MB60 chassis.
16. VE20464600 LVDS CABLE // It's the cable between panel and main board. Fix it to the t-con board of the panel and the socket of CN137 position on the MB60 chassis.
17. VE30067738 INVERTER CABLE // There are 4 inverter cable between panel and power board. Fix 2 cables, which come from top of the panel, to the sockets of PL101 + PL102 positions on the IPS17 board.  
Fix 2 cables, which come from bottom of the panel, to the sockets of PL103 + PL104 positions on the IPS17 board. (Please look the picture of item 8)



May/2011

SANYO Electric Co., Ltd.