



FILE NO.

## SERVICE MANUAL

## LCD-46XR11F(B)

PRODUCT CODE No.

1 682 351 67: PAL-B/G (Australia)

NTSC(AV)

## LCD TV

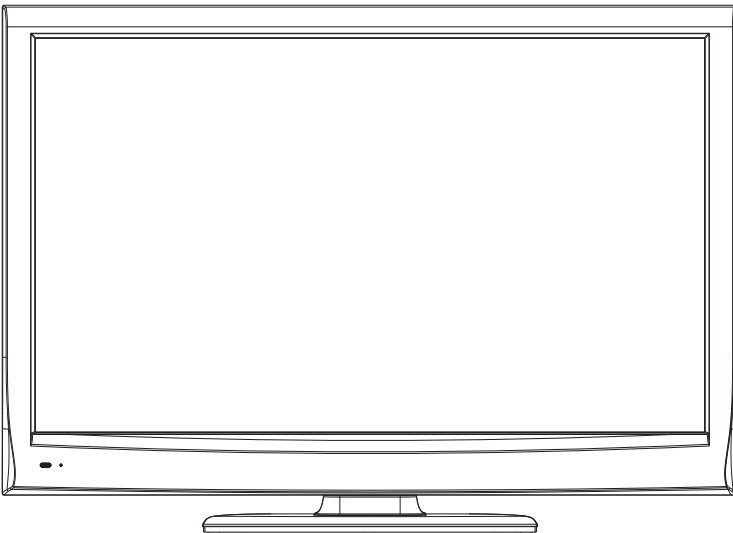

REFERENCE No.:SM0915211

## CONTENTS

Safety precautions.....	3
Alignment instructions .....	5
Software upgrade instructions .....	12
Working principle analysis.....	15
Block diagram.....	17
IC block diagram.....	18
Wiring diagram .....	21
Troubleshooting flow chart .....	22
Schematic diagram.....	25
APPENDIX-A: Assembly list	
APPENDIX-B: Exploded View	
Assembling the Stand	
WALL MOUNTING INSTRUCTIONS	

**Attention:** This service manual is only for service personnel to take reference with. Before servicing please read the following points carefully.

## **Safety precautions**

### **1. Instructions**

Be sure to switch off the power supply before replacing or welding any components or inserting/plugging in connection wire. Anti static measures must be taken (throughout the entire production process!):

- a) Do not touch here and there by hand at will;
- b) Be sure to use anti static electric iron;
- c) It's necessary for the welder to wear anti static gloves.

Please refer to the part list before replacing components that have special safety requirements. Do not replace with different components with different specs and type at will.

### **2. LCD servicing precautions**

2.1 Screens are different from one model to another and therefore not interchangeable. Be sure to use the screen of the original model for replacement.

2.2 The operation voltage of LCD screen is 700-825V. Be sure to take proper measures in protecting yourself and the machine when testing the system in the course of normal operation or right after the power is switched off. Please do not touch the circuit or the metal part of the module that is in operation mode. Relevant operation is possible only one minute after the power is switched off.

2.3 Do not use any adapter that is not identical with the TV set. Otherwise it will cause fire or damage to the set.

2.4 Never operate the set or do any installation work in bad environment such as wet bathroom, laundry, kitchen, or nearby fire source, heating equipment and devices or exposure to sunlight etc. Otherwise bad effect will result.

2.5 If any foreign substance such as water, liquid, metal slices or other matters happens to fall into the module, be sure to cut the power off immediately and do not move anything on the module lest it should cause fire or electric shock due to contact with the high voltage or short circuit.

2.6 Should there be smoke, abnormal smell or sound from the module, please shut the power off at once. Likewise, if the screen is not working after the power is on or in the course of operation, the power must be cut off immediately and no more operation is allowed under the same condition.

2.7 Do not pull out or plug in the connection wire when the module is in operation or just after the power is off because in this case relatively high voltage still remains in the capacitor of the driving circuit. Please wait at least one minute before the pulling out or plugging in the connection wire.

2.8 When operating or installing LCD please don't subject the LCD components to bending, twisting or extrusion, collision lest mishap should result.

2.9 As most of the circuitry in LCD TV set is composed of CMOS integrated circuits, it's necessary to pay attention to anti statics. Before servicing LCD TV make sure to take anti static measure and ensure full grounding for all the parts that have to be grounded.

2.10 There are lots of connection wires between parts behind the LCD screen. When servicing or moving the set please take care not to touch or scratch them. Once they are damaged the screen

would be unable to work and no way to get it repaired.

If the connection wires, connections or components fixed by the thermotropic glue need to disengage when service, please soak the thermotropic glue into the alcohol and then pull them out in case of damage.

2.11 Special care must be taken in transporting or handling it. Exquisite shock vibration may lead to breakage of screen glass or damage to driving circuit. Therefore it must be packed in a strong case before the transportation or handling.

2.12 For the storage make sure to put it in a place where the environment can be controlled so as to prevent the temperature and humidity from exceeding the limits as specified in the manual. For prolonged storage, it is necessary to house it in an anti-moisture bag and put them altogether in one place. The ambient conditions are tabulated as follows:

Temperature	Operation range	+5 ~ +35 °C
	Storage range	-20 ~ +60 °C
Humidity	Operation range	20% ~ 80%
	Storage range	10% ~ 90%

2.13 Display of a fixed picture for a long time may cause a permanent after-image on the screen, as commonly called “ghost shadow”. The degree of the after-image varies with the maker of LCD screen. This phenomenon doesn’t represent failure. This “ghost shadow” may remain in the picture for a period of time (several minutes). But when operating it please avoid displaying still picture in high brightness for a long time.

### **3. Installation precautions**

3.1 The front panel of LCD screen is made of glass. When installing it please make sure to put it in place.

3.2 For service or installation it’s necessary to use specified screw lest it should damage the screen.

3.3 Be sure to take anti dust measures. Any foreign substance that happens to fall down between the screen and the glass will affect the receiving and viewing effect

3.4 When dismantling or mounting the protective partition plate that is used for anti vibration and insulation please take care to keep it in intactness so as to avoid hidden trouble.

3.5 Be sure to protect the cabinet from damage or scratch during service, dismantling or mounting.

# Adjustment Instruction

## 1 Safety Instructions

- 1.1 Power supply must be cut off when replacing or welding any component or inserting / pulling out connective lines;
- 1.2 Anti-electrostatic measures must be carried out during the whole producing processes!
  - a) Do not touch IC by hands at will;
  - b) Use anti-electrostatic iron;
  - c) Welder must wear anti-electrostatic glove;
- 1.3 Replacing any component with special safety requirement must refer to component list without changing its specification and model at will.

## 2 Adjustment Equipments

Multimeter or oscilloscope

VG-849

CA-210

USB storage device

DVD ( HDMI 1.4 supported ) or equipments with the same functions

## 3 Adjustment Processes

### 3.1 Power voltage checking

According to the wiring diagram specified by “Product Specification”, connect power board assembly, data processing assembly, IR/Key board assembly, backlight board assembly correctly, supply with power, press button  to power on the TV set.

Make sure the voltages of socket X601 each pin on the main board are correct. Voltage value and range are listed as Table 1:

Table 1 Voltage of X601 each pin

X601	Pin1,2	3,4	5,6	7,8	9	10	11	12	13
Voltage	24V±5%	0	12 V±5%	0	≤5.2V	5 V±5%	5 V±5%	≤5.2 V	≤5.2 V
Function	AMP_PWR	GND	12V	GND	PWR_SW	Main 5V	+5V STB	BL_PWM	BL_ON

3.2 Adjustment flow as Fig. 1:

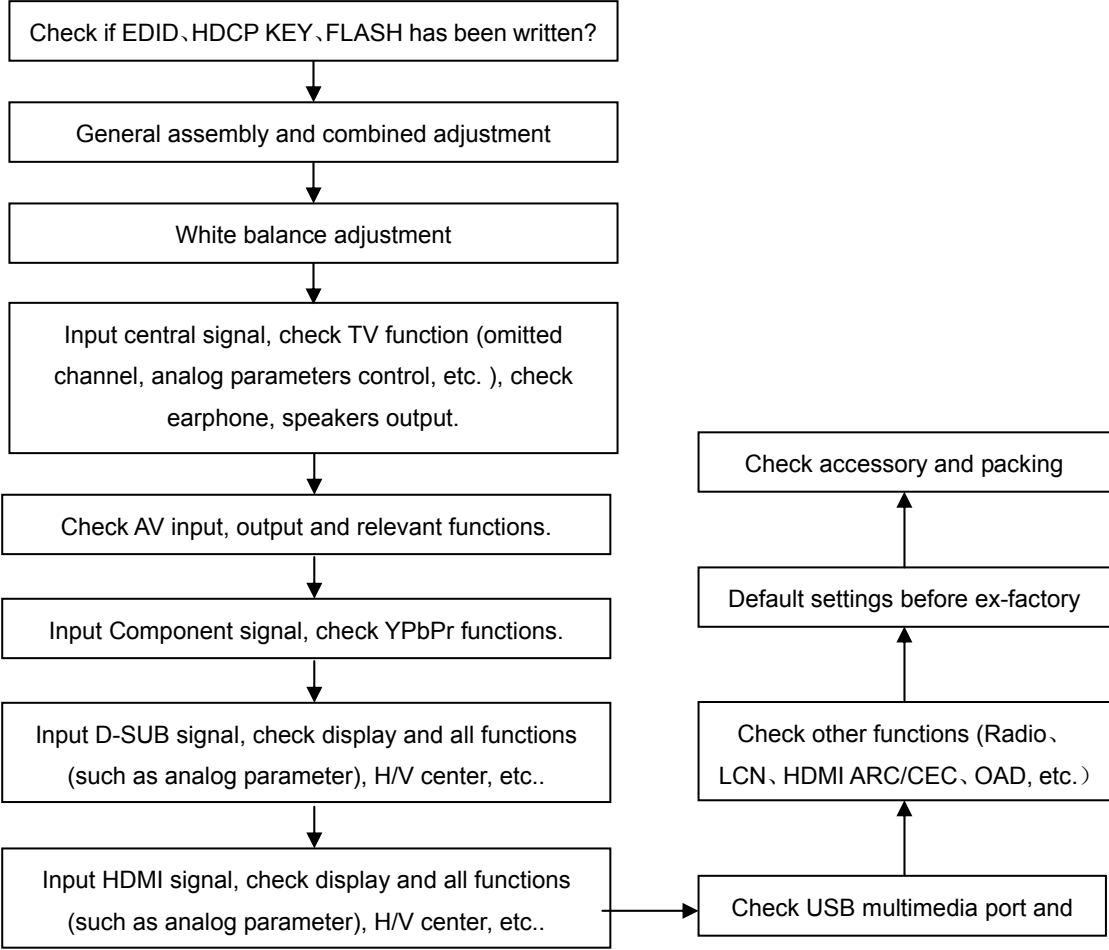

Fig. 1 Adjustment flow chart

## 4 Adjustment Instruction

### 4.1 The unit adjustment

4.1.1 According to the wiring diagram specified by "Product Specification", connect power/backlight board assembly, data processing assembly, IR/Key board assembly correctly, supply with power, turn on the TV set. Check display.

#### 4.1.2 Factory menu instruction

- a) Press key "**INPUT**", then press digital keys "**2、5、8、0**" in turn to enter into primary factory menu;
- b) Press keys "**▲**" and "**▼**" to move cursor to each page of primary factory menu, then press key "**OK**" to enter into submenu page;
- c) Press keys "**▲**" and "**▼**" to move cursor upward or downward within any one page;
- d) Press keys "**◀**" and "**▶**" to do adjustment when move cursor to one item;
- e) Press key "**MENU**" to exit submenu page to the superior factory menu;
- f) Press key "**EXIT**" to exit factory menu in any case;
- g) Press key "**OK**" to enter the inferior factory submenu;
- h) Factory menu item: **Aging Mode** to be used for aging the TV set; red, green blue and white full screen picture displays in turn; default setting is OFF;
- i) Factory menu item: **ADC ADJUST** to be used for ADC calibration for VGA and Component;
- j) Factory menu item: **Fac. Channel Preset** to be used for factory channel presetting; central signal digital frequency value for Australia program is set as CH28(529.5 MHz) and CH33(564.5 MHz); original digital program presetting could not change if central signal setting has any modification, so please search for digital program manually by perform item DTV of menu Channel;
- k) Factory menu item: **Color Temp.** to be used for white balance adjustment;
- l) Factory menu item: **Store Setting Init.**
- m) Factory menu item: **USB SW Update** to be used for software updating from USB port; when U disk containing updating software is inserted into USB port, choose the item to perform updating process;
- n) Factory menu item: **Other Settings** include settings of EEPROM Init, MEMC Update, Power mode, MST DEBUG, ISP MODE, Backlight, SSC, NONLINEAR, Video Quality, Audio Quality, Light Sensor, Overscan, etc.; no need any adjustment normally.
- o) Factory menu item: **Shipment** to be used for initializing user data; Success flag will display after initialization, then press KEY POWER only to power off the TV set.
- p) Please perform **EEPROM Init** before adjustment for the first time if software has been upgraded or data have been kept in EEPROM.

#### 4.1.3 ADC calibration for D-SUB channel

- a) Switch to D-SUB channel;
- b) Press key "**INPUT**", then press digital keys "**2、5、8、0**" in turn to enter into primary factory menu;
- c) Move cursor to item "**ADC ADJUST**" and press key "**OK**" to enter into the inferior submenu;
- d) Input D-SUB signal (**VG-849 Timing:856 (1024×768/60 Hz), Pattern:914 Chess Pattern**); move cursor to item "**MODE**", press keys "**▲**" and "**▼**" to choose item "**RGB**", then move cursor to item "**AUTO ADC**" and press key "**OK**" to perform auto adjustment until prompt "**success**" displays;

#### 4.1.4 ADC calibration for Component channel

- a) Switch to Component channel;
- b) Press key “**INPUT**”, then press digital keys “**2、5、8、0**” in turn to enter into primary factory menu;
- c) Move cursor to item “**ADC ADJUST**” and press key “**OK**” to enter into the inferior submenu;
- d) Input Component signal (**VG-849 Timing:972(1080i), Pattern:918 100% color bar**); move cursor to item “**MODE**”, press keys “**▲**” and “**▼**” to choose item “**YPbPr**”, then move cursor to item “**AUTO ADC**” and press key “**OK**” to perform auto adjustment until prompt “**success**” displays;

#### 4.2 White balance adjustment

Unless specified by customer, default settings of **COOL color temperature is 12000K and chromatic coordinates is (272、278)**; referenced settings of **Normal** color temperature is **9300K** and chromatic coordinates is (**285、293**); referenced settings of **Warm** color temperature is **6500K** and chromatic coordinates is (**313、329**);

Default setting is **Normal**.

#### 4.3 Adjustment procedures

The TV set should be working above 30 minutes to be in a stabler state before adjustment. Use CA-210 BBY channel to adjust white balance;

- a) Switch to HDMI channel;
- b) Press key “**INPUT**”, then press digital keys “**2、5、8、0**” in turn to enter into primary factory menu;
- c) Move cursor to item “**W/B ADJUST**” and press key “**OK**” to enter into the inferior submenu;
- d) Input HDMI signal (**VG-849 Timing:856(1024×768/60 Hz), Pattern:921 16 step Gray**); move cursor to item “**MODE**”, press keys “**▲**” and “**▼**” to choose item “**HDMI**”, then move cursor to item “**TEMPERTURE**” and press keys “**▲**” and “**▼**” to choose “**COOL**”;
- e) Fix “**G GAIN**”, adjust “**R GAIN, B GAIN**” to set 14<sup>th</sup> chromatic coordinates as (272、278);
- f) Fix “**G OFFSET**”, adjust “**R OFFSET、B OFFSET**” to set 4<sup>th</sup> chromatic coordinates as (272、278);
- g) To make sure chromatic coordinates of bright scale are (**X=272±10, Y=278±10**) and chromatic coordinates of dark scale are (**X=272±10, Y=278±10**) during adjusting;
- h) Move cursor to item “**COPY ALL**” to copy white balance data to other channels except **DTV** channel;
- i) Check if chromatic coordinates of **NORMAL** and **WARM** meet the requirements (permitted error of **NORMAL** bright scale: **x±10, y±10**, permitted error of **NORMAL** dark scale: **x±10, y±10**; permitted error of **WARM** bright scale and dark scale: **x±10, y±10**); if not, adjust “**R\_GAIN /B\_GAIN/R\_OFF/B\_OFF**” to be up to the requirements and then save the data;
- j) Perform “**Copy All**” for Normal/Warm adjustments except **DTV** channel;
- k) Check if chromatic coordinates of other channels meet the requirements, if not, do adjustment for nonstandard channel alone with the same procedures from b) to j) as HDMI channel’s and then save the data;
- l) Switch to HDMI channel, change to 16-grey-scale program from central signal source, adjust white balance with the same procedures from e) to g) as HDMI channel’s; but **pay attention not to perform “COPY ALL”!**
- m) Inspect all channels after completing adjustment to check if display is normal;
- n) Refer to the following rule for adjustment:



B Gain/Offset: adjust B Gain/Offset downward, coordinates of X and Y will increase, adjust B Gain/Offset upward, coordinates of X and Y will decrease;

R Gain/Offset: adjust R Gain/Offset will affect X value, but affect Lv value slightly, adjust R Gain/Offset upward, coordinates of X will increase, adjust R Gain/Offset downward, coordinates of X will decrease;

G Gain/Offset: adjust G Gain/Offset will affect Y value, and affect Lv value greatly, adjust G Gain/Offset upward, coordinates of Y will increase, adjust G Gain/Offset downward, coordinates of Y will decrease;

Note: Sanyo customer requires that default color temperature is Normal, adjust white balance of color temperature Normal and Cool in Dynamic picture mode; for other customers, please adjust white balance of color temperature Cool in Dynamic picture mode.

## 5 Function check

### 5.1 TV functions

Input central signal to RF port, enter into menu Channel first, then search for programs automatically and check if there is any omitted program; check the speakers output and the picture display;

### 5.2 AV port

Input AV signal with formats listed as Table 1 separately, check picture, sound and other functions;

Table 1 AV video signal formats

No.	Lines per frame	H.- Freq. (kHz)	V.- Freq. (Hz)	Note
1	525	15.734/15.75	59.94/60	NTSC, NTSC4.43, PAL60, PAL-M
2	625	15.625	50	PAL, PAL-N, SECAM

### 5.3 Component port

Input Component signal from VG-849 with formats listed as Table 2 separately, check picture and sound in the case of power-on, switching channel, changing mode, etc.;

Table 2 Component signal formats

No.	Definition	H.- Freq. (kHz)	V.- Freq. (Hz)	Dot pulse Freq. (MHz)	Note
1	720×480	15.734/15.75	59.94/60	13.5/13.514	480i (NTSC)
2	720×576	15.625	50	13.5	576i (PAL)
3	720×480	31.469/31.5	59.94/60	27/27.027	480p (NTSC PROG)
4	720×576	31.25	50	27	576p (PAL PROG)
5	1280×720	37.5	50	74.25	720p (50p)
6	1280×720	44.955/45	59.94/60	74.176/74.25	720p (59.94p/60p)
7	1920×1080	28.125	50	74.25	1080i (50i)
8	1920×1080	33.75	59.94/60	74.176/74.25	1080i (59.94p/60p)
9	1920×1080	26.973	23.976	74.176	1080p (23.97p)
10	1920×1080	27	24	74.25	1080p (24p)
11	1920×1080	28.125	25	74.25	1080p (25p)
12	1920×1080	33.716	29.97	74.176	1080p (29.97p)
13	1920×1080	33.75	30	74.25	1080p (30p)
14	1920×1080	56.25	50	148.5	1080p (50p)
15	1920×1080	67.432/67.5	59.94/60	148.35/148.5	1080p (59.94p/60p)

#### 5.4 D-SUB port

Input D-SUB signal from VG-849 with formats listed as Table 3 separately, check picture and sound; if H./V. of picture displays abnormally, enter into main menu Picture->Screen->Auto Adjust to perform auto calibration.

Table 3 D-SUB signal formats

No.	Definition	H.- Freq. (kHz)	V.- Freq. (Hz)	Dot pulse Freq. (MHz)	Note
1	640×480	31.469	59.94	25.175	IBM
2	720×400	31.469	70.086	28.322	IBM
3	640×480	37.861	72.809	31.5	VESA
4	640×480	37.5	75	31.5	VESA
5	800×600	35.156	56.25	36	VESA
6	800×600	37.879	60.317	40	VESA
7	800×600	48.077	72.188	50	VESA
8	800×600	46.875	75	49.5	VESA
9	1024×768	48.363	60.004	65	VESA
10	1024×768	56.476	70.069	75	VESA
11	1024×768	60.023	75.029	78.75	VESA
12	1152×864	67.5	75	108	VESA
13	1280×960	60	60	108	VESA
14	1280×1024	63.98	60.02	108	VESA
15	1280×1024	80	75	135	SXGA
16	1360×768	47.7	60	85.5	WXGA
17	1440×900	55.9	60	106.5	WXGA+ ( Panel National only)
18	1680×1050	65.3	60	146.25	WSXGA+ ( Panel National only)
19	1920×1080	67.5	60	148.5	

#### 5.5 HDMI port

HDMI port supports all signal formats supported by Component port (Table 2) and D-SUB port (Table 3), furthermore, it can also support signal with formats listed as Table 4 and Table 5 (video and audio combination). Check picture and sound in the case of power-on, switching channel, changing mode, etc.;

Table 4 Digital HDMI signal formats

No.	Definition	H.- Freq. (kHz)	V.- Freq. (Hz)	Dot pulse Freq. (MHz)	Note
1	720(1440)×480	15.734/15.75	59.94/60	27/27.027	720(1440)×480i@59.94/60 Hz, 4:3/16:9
2	720(1440)×576	15.625	50	27	720(1440)×576i@50 Hz,4:3/16:9

Table 5 Video & audio signal formats of digital HDMI

No.	Item	Unit	Parameter	Note
1	Video		Deep color: RGB 4:4:4 (24 bit/pixel, 30 bit/pixel, 36 bit/pixel) 、 YUV 4:4:4 (24 bit/pixel, 30 bit/pixel, 36 bit/pixel) 、 For "1080p, deep color", only support "30 bit/pixel" YUV 4:2:2(16 bit)、YUV 4:2:2(20 bit)、YUV 4:2:2(24 bit)	
2	Audio sample frequency	KHz	32、44.1、48	
3	Audio data width	Bit	16、20、24	

## 5.6 USB port

### 5.6.1 PVR function

Insert a formatted U disk in which recorded programs have been saved; press key "Record List" to choose and play one program, check picture, sound and other functions;

### 5.6.2 Media playing function

Insert a U disk kept files of picture, sound and video, check picture, sound and other functions;

Supported media formats as below:

Photo: JPEG, BMP, PNG

Video: H.264 , MPEG-1, MPEG-2, VC-1, FLV

Audio: WMA, MP3, M4A (AAC)

## 5.7 Music port (depending on different models whether contain the port or not)

Input audio signal to side music port (analog audio input) from audio output equipment, check audio output.

## 5.8 Other functions check

- a) Check timing on/off, sleeping time off, picture/sound mode, OSD, stereo, digital audio port, etc.;
- b) Check pure digital audio programs (RADIO) ;
- c) Check logical channel number (LCN);
- d) Check HDMI ARC;
- e) Check HDMI CEC;
- f) Check OAD for special customer;

## 6 User Menu Setting before shipment

Enter into Factory Menu and choose "Shipment" to perform presetting before shipment;

Main procedures are described as follow:

- a) Clear out all programs;
- b) Clear out information of VCHIP, parent control, etc.;
- c) Default user analog parameter setting;
- d) Recover default password;
- e) Set Menu Language as English;
- f) Set Power mode as Off.

# Software Upgrading Instruction

Software Upgrading Instruction as Table 6

Table 6 Software Upgrading Instruction

Location	Part No.	Part model	Software function	SMT before upgrading	Upgrading method
N103	5272532006	EN25Q32A-100HIP	FLASH	Yes	Upgrade with ALL100, etc., need write protection, refer to Note1;
N105	5272404005	CAT24C04WI-GT3	HDCP KEY	Yes	Upgrade with ALL100, etc.
NB03	5272402003	CAT24C02WI	VGA EDID	Yes	

**Note 1** Write protection setting method: enter into ALL-100 upgrading interface “AUTO”, tick off “Config”, press “config Setting”, set option “Protect” as “All Protect” and “SRWD” as “Enable”, then press “OK” to complete write protection setting;  
Please make sure option “Config” is ticked off during software upgrading and reset write protection after ALL-100 upgrading software is opened each time;

**Note 2** Upgrading method with ISP upgrading instrument:

- 1) Main board upgrading: connect 4-core line of ISP to Debug port (X603) on main board;  
The Unit upgrading: connect both VGA ports of ISP and main board, enter into factory menu and set “ISP Mode” as “ON”;
- 2) Use Mstar upgrading instrument (V4.4.2.0 or higher version), enter into menu “Device”, tick off “WP Pin pull to high during ISP” to make sure Flash hardware write protection is removed and erasing process is normal; please refer to Fig.2;

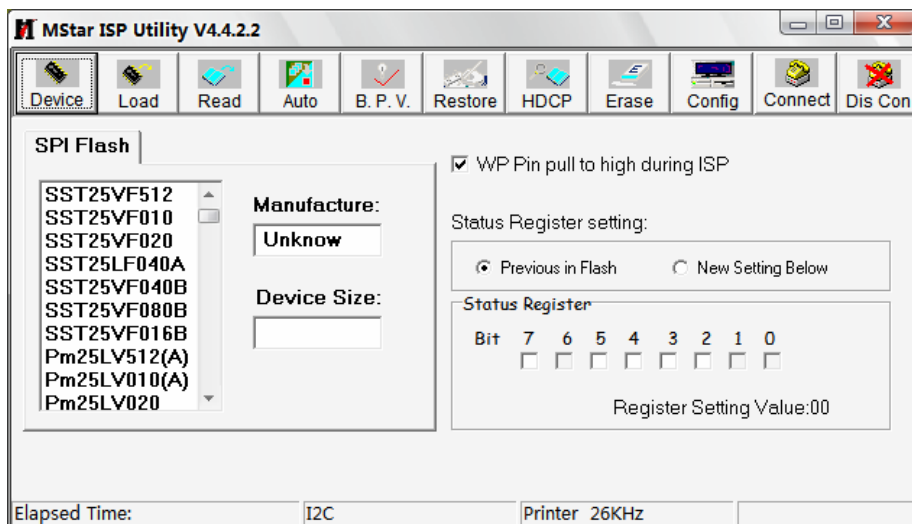

Fig. 2 Write protection setting

- 3) Press menu “Connect”, dialog box “Device Type is MX25L64” (device type depending on parts used on board actually) will display to show successful connection; please refer to Fig. 3;

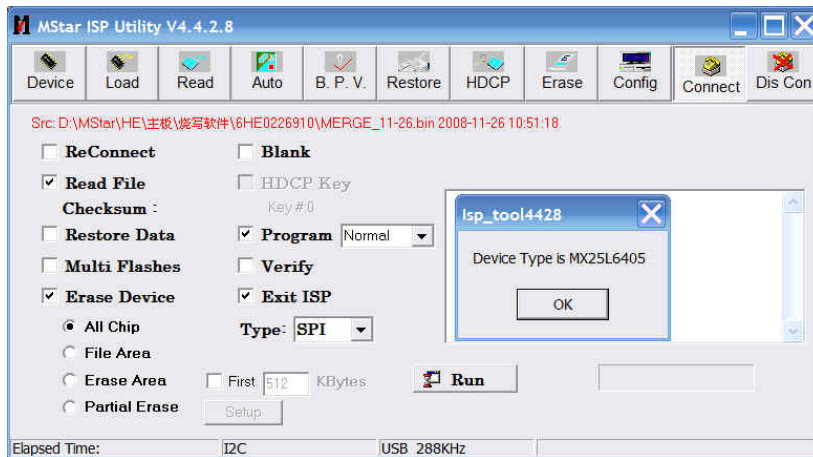

Fig. 3 Device MX25L64 successful connection

If connection is failed, press the first menu “Device” and choose “MX25L64” manually, then press “Connect”;

- 4) Press “Read”, choose upgrading file, such as “MERGE.bin”; please refer to Fig. 4;

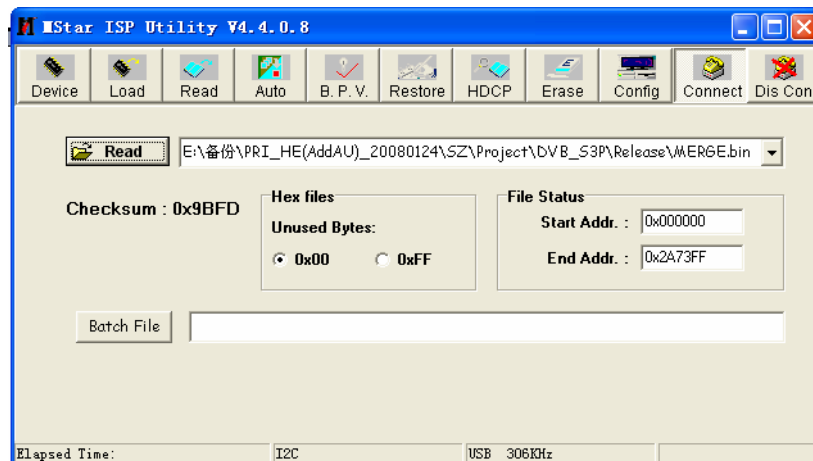

Fig. 4 Choosing upgrading file

- 5) Press “Auto”, tick off “All chip”, “program” and other necessary options; please refer to Fig. 5;

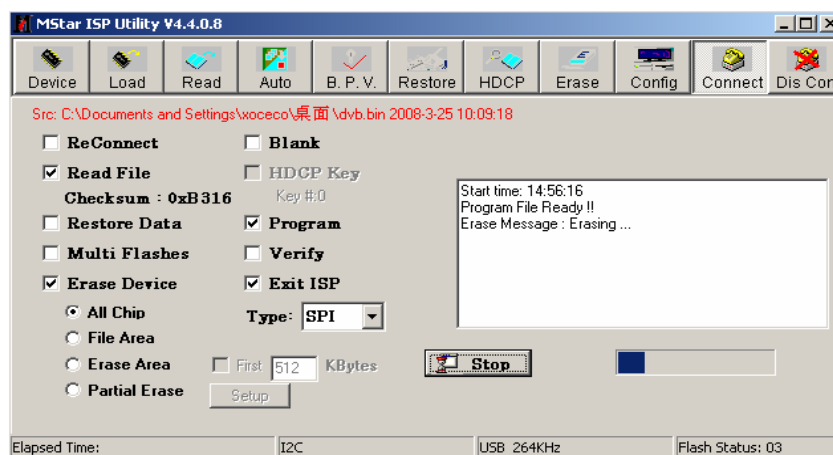

Fig. 5 Options

6) Press “Run” shown as Fig. 4 to perform upgrading in two steps, “Erase” and “Program”;

Normal upgrading process:

The first step “Erasing..., Flash Status: 03” will last for some time, or erasing is failed if the step passes over immediately; please confirm procedure 2) to perform upgrading again;

The second step is “Programming..., Flash Status:00”;

Then prompt “Pass” displays;

7) Prompt “Pass” will display by button “Run” when upgrading succeeds; please refer to Fig. 6;

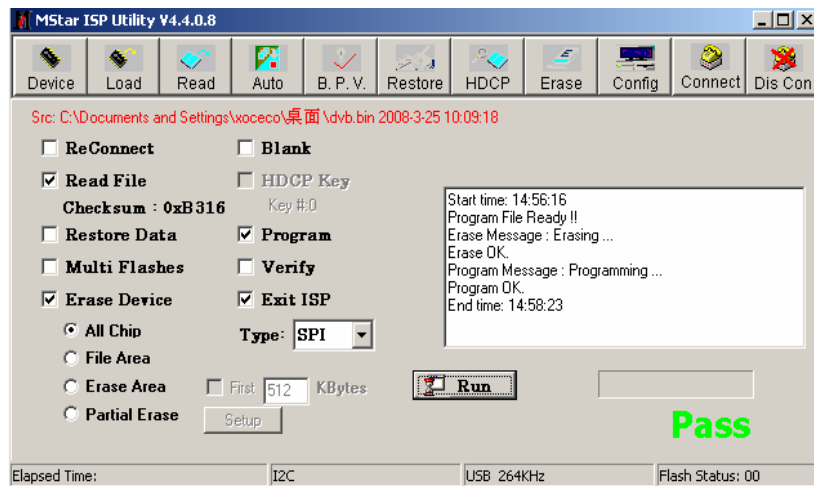

Fig. 6 Prompt “Pass” displayed by “Run” when upgrading succeeds

8) Need not exit ISP upgrading interface if there are other TV sets to be upgraded , only procedures 3) and 6) need repeat;

### Note 3 Upgrading with USB:

1) Make sure U disk is formatted as FAT32;

2) Copy software file named as “Merge. bin” to U disk;

3) Turn on the TV set, then insert U disk in USB port of the unit;

a) First press key “INPUT”, then press keys “2、5、8、0” in turn to enter into primary factory menu;

b) Choose “USB SW Update” to begin upgrading;

4) Upgrading processes:

A、 Read data from U disk while data indicator light of U disk is twinkling at the same time;

B、 Upgrading flash, then the unit will be in “standby” mode;

5) Cut off the power supply and then restart the TV set, enter into factory menu to verify version and time parameter, then perform “EEPROM Init” to complete the whole upgrading processes.

Note: The USB upgrading method can not be sure to be suitable for all kinds of U disk, so try another U disk if necessary.

## Working Principle of the Unit

### 1、ATV PAL signal flow

Receive RF PAL analog signal and send it to **XC5200C** (D/A silicon Tuner controlled by main chip **MSD309PX** through I<sup>2</sup>C bus) to be demodulated, then differential IF signal is send out to main chip **MSD309PX** analog demodulation to be demodulated to get analog CVBS video signal and SIF sound signal.

CVBS video signal is processed by back-end video decoder, anti-interlacing part, video processor and zoom controller, then LVDS signal is outputted to drive display panel.

SIF sound signal is processed by back-end demodulator to get analog sound signal, then processed by pre-amplifier, acoustic effect processor and volume controller to get two parts of signals: the analog part of signal is sent to earphone amplifier **MAX9820** to be amplified and then outputted to earphone jack; the digital part of signal I2S is sent to digital audio power amplifier **TAS5711** to be processed by D/A converter and power amplifier, then outputted to drive speakers.

### 2、DVB-T signal flow

Receive RF DVB-T digital signal and send it to **XC5200C** (D/A silicon Tuner controlled by main chip **MSD309PX** through I<sup>2</sup>C bus) to be processed by down-frequency-conversion, then differential IF signal is send out to main chip **MSD309PX** digital demodulation to be demodulated, then standard parallel transmission flow is outputted to back-end demultiplexer and decoder to be processed.

Video channel: demultiplexing digital video signal is processed by **MSD309PX** decoder and video processor, then LVDS signal is outputted to drive display panel;

Audio channel: demultiplexing digital audio signal is processed by **MSD309PX** decoder and audio processor, then double-sound-track analog audio signal (stereo) is outputted to **MSD309PX** to be processed by preamplifier, acoustic effect processor and volume controller to get two parts of signals: the analog part of signal is sent to earphone amplifier **MAX9820** to be amplified and then outputted to earphone jack; the digital part of signal I2S is sent to digital audio power amplifier **TAS5711** to be processed by D/A converter and power amplifier, then outputted to drive speakers.

### 3、AV input signal flow

AV video signal is inputted to main chip **MSD309PX** to be processed by video decoder, anti-interlacing part, video processor and zoom controller, then LVDS signal is outputted to drive display panel;

AV audio signal is processed by voltage divider, resistance matcher and AC coupler, then sent to main chip **MSD309PX** to be processed by acoustic effect processor and volume controller to get two parts of signals: the analog part of signal is sent to earphone power amplifier **MAX9820** to be amplified and then outputted to earphone jack; the digital part of signal I2S is sent to digital audio power amplifier **TAS5711** to be processed by D/A converter and power amplifier, then outputted to drive speakers.

### 4、D-SUB/YPbPr input signal flow

D-SUB、YPbPr video signal is inputted to main chip **MSD309PX** to be processed by A/D convertor, video decoder, anti-interlacing part, video processor and zoom controller, then LVDS signal is outputted to drive display panel;

D-SUB、YPbP audio signal is processed by voltage divider, resistance matcher and AC coupler, then

sent to main chip **MSD309PX** to be processed by acoustic effect processor and volume controller to get two parts of signals: the analog part of signal is sent to earphone power amplifier **MAX9820** to be amplified and then outputted to earphone jack; the digital part of signal I2S is sent to digital audio power amplifier **TAS5711** to be processed by D/A convertor and power amplifier, then outputted to drive speakers.

#### 5、 HDMI input signal flow

HDMI video signal is inputted to main chip **MSD309PX** to be processed by video decoder, video processor and zoom controller, then LVDS signal is outputted to drive display panel;

HDMI audio signal is sent to main chip **MSD309PX** to be processed by audio decoder, pre-amplifier, acoustic effect processor and volume controller to get two parts of signals: the analog part of signal is sent to earphone power amplifier **MAX9820** to be amplified and then outputted to earphone jack; the digital part of signal I2S is sent to digital audio power amplifier **TAS5711** to be processed by D/A convertor and power amplifier, then outputted to drive speakers.



# Block Diagram

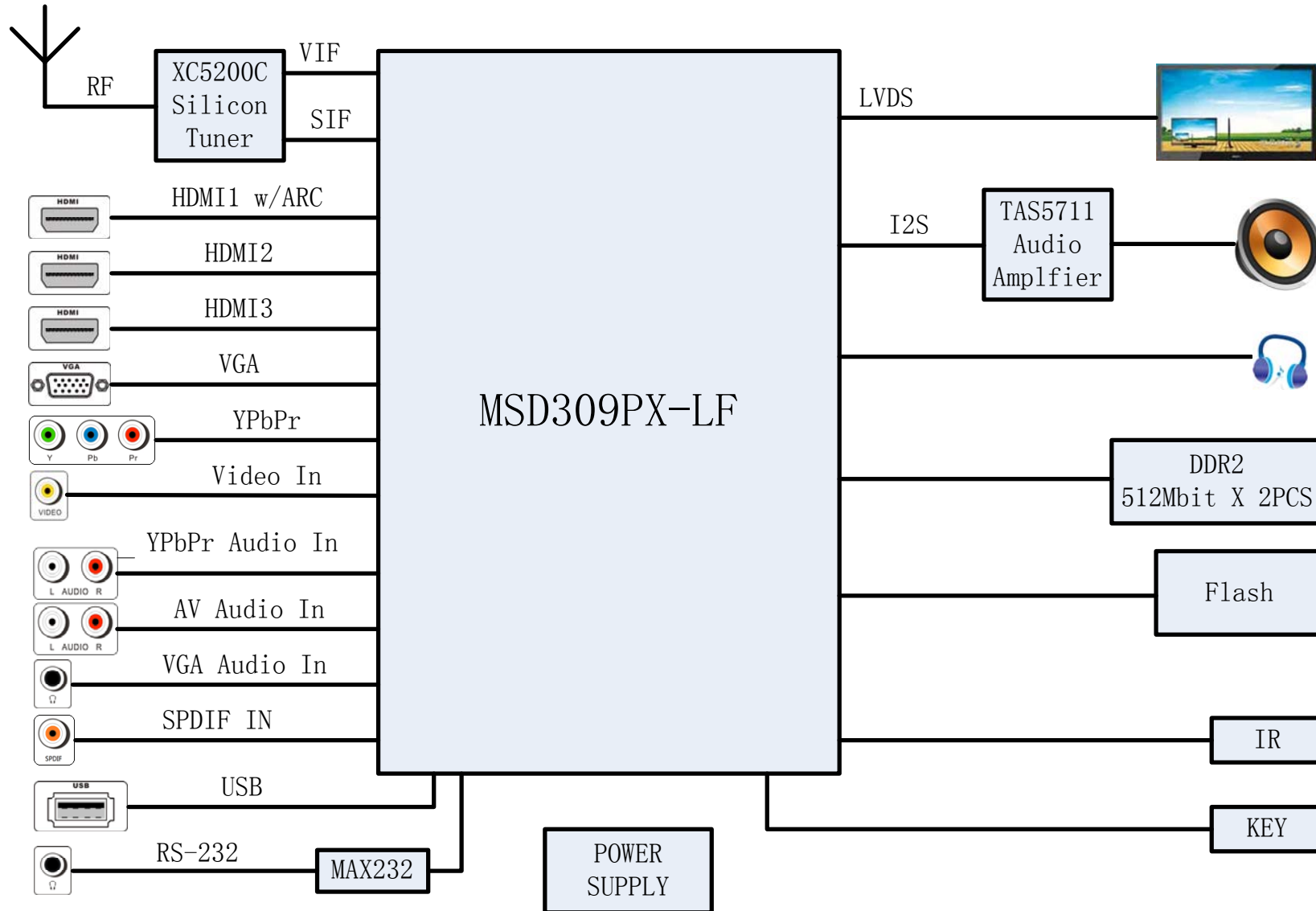

# IC Block Diagram

## 1、 TUNER IC XC5200C

The Single-Chip Multi-Standard Tuner XC5200C supports all analog TV formats transmitted worldwide in the 42-1000 MHz band on either cable or terrestrial broadcast channels. It implements on-chip tuning, and channel filtering without external (SAW) filters and has no manually tunable parts.

The broadband tuner converts the selected channel into an Intermediate Frequency (IF), which is then sampled by an internal high-resolution analog-to-digital converter (A/D) for further processing.

The IF signals are filtered using a standard-dependent high-rejection channel filter and converted to a user programmable output frequency. At the output of the D/A converter, the TV signal is low-pass filtered using a high-performance smoothing filter and input to a variable gain amplifier. The IF output amplifier gain can be controlled via an external analog signal on Vagc.

The XC5200C architecture is summarized in Figure 1. XC5200C Block Diagram.

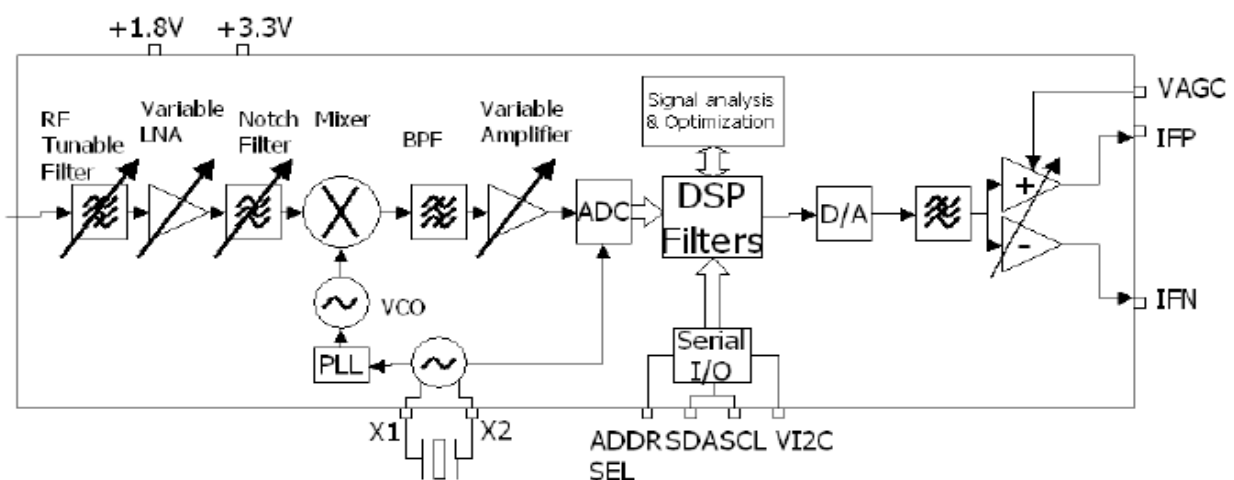
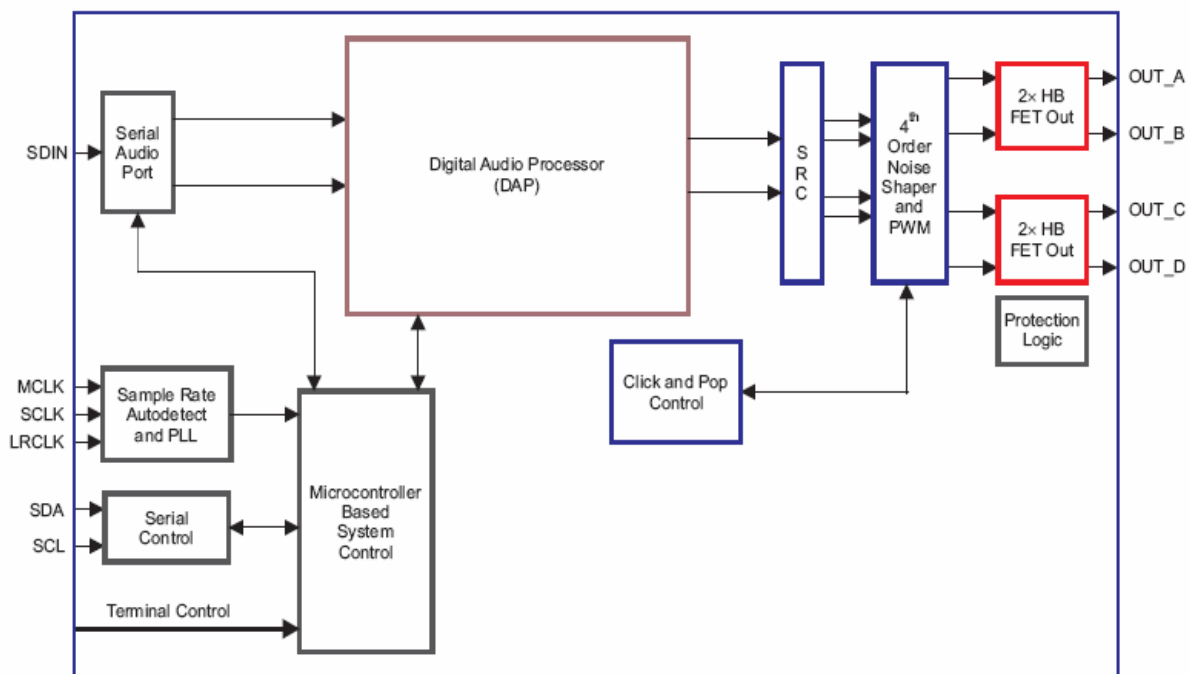

Figure 1. XC5200C Block Diagram

## 2、 AMP IC TAS5711

The TAS5711 is a 20-W, efficient, digital audio power amplifier for driving stereo bridge-tied speakers. One serial data input allows processing of up to two discrete audio channels and seamless integration to most digital audio processors and MPEG decoders. The device accepts a wide range of input data and data rates. A fully programmable data path routes these channels to the internal speaker drivers.

The TAS5711 is an I2S slave-only device receiving all clocks from external sources. The TAS5711 operates with a PWM carrier between 384-kHz switching rate and 352-KHz switching rate depending on the input sample rate. Over sampling combined with a fourth-order noise shaper provides a flat noise floor and excellent dynamic range from 20 Hz to 20 kHz.



### 3、 AUDIO IC MAX9820

The MAX9820 Windows Vista®-compliant stereo headphone amplifier is designed for portable Equipment where board space is at a premium. It features Maxim's DirectDrive® architecture to produce a ground-referenced output from a single supply, eliminating the large output-coupling capacitors required by conventional single-supply headphone amplifiers.

The MAX9820 features an undervoltage lockout that prevents over discharging of the battery During brownout conditions, click-and-pop suppression that eliminates audible transients on startup, a low-power shutdown mode, and thermal-overload and short-circuit protection. Additionally, the MAX9820 suppresses RF radiation received by input and supply traces acting as antennas and prevents the amplifier from demodulating the coupled noise.

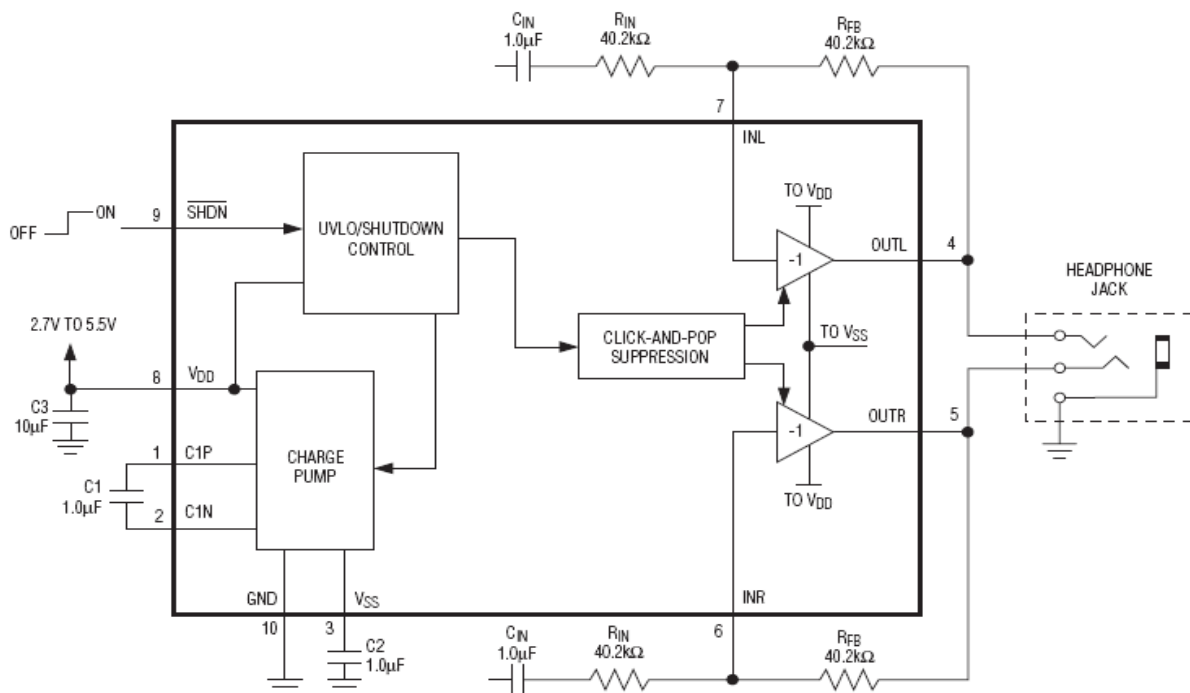

# Wiring Diagram

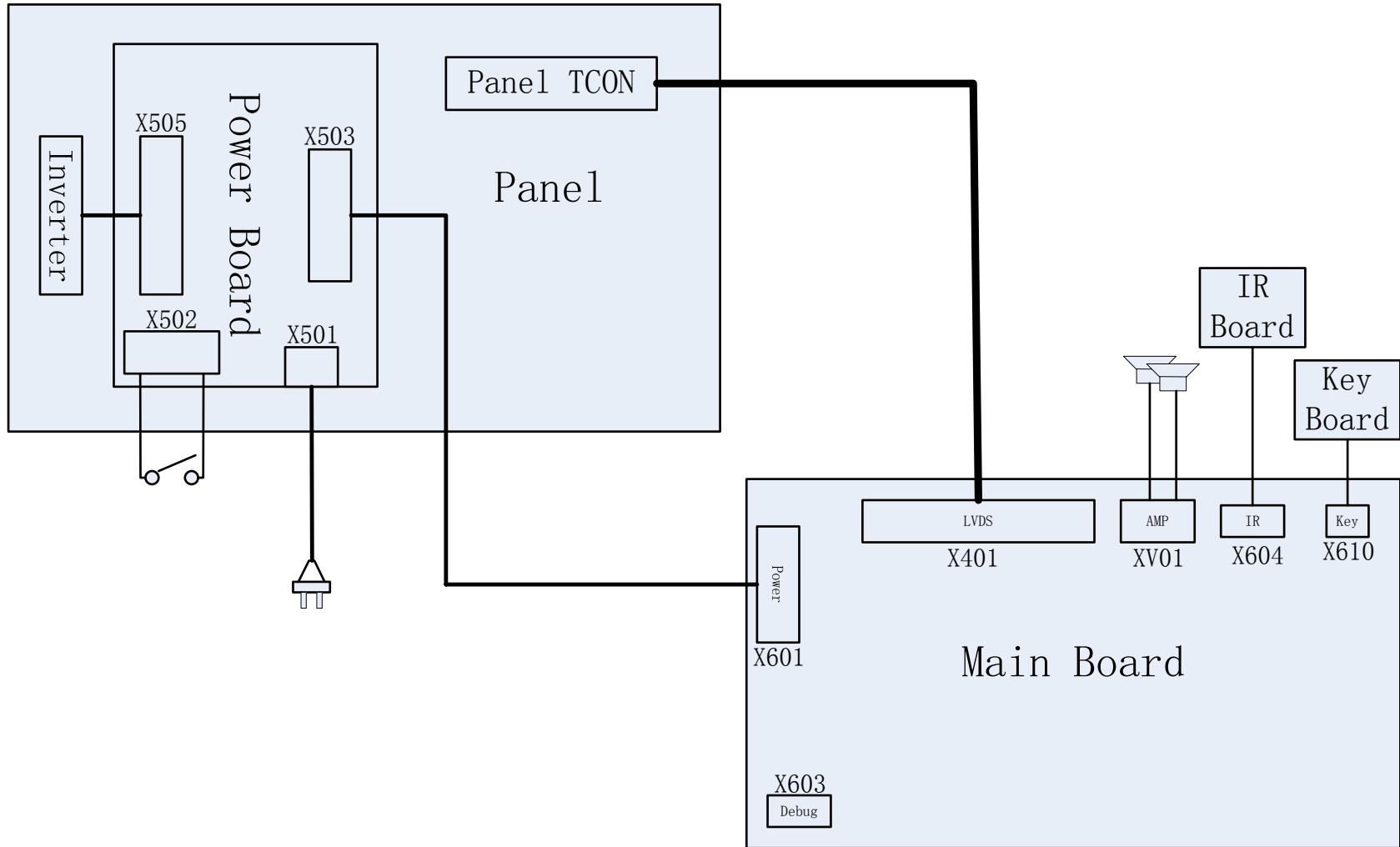

# Troubleshooting Block Diagram

1. Panel doesn't light up.

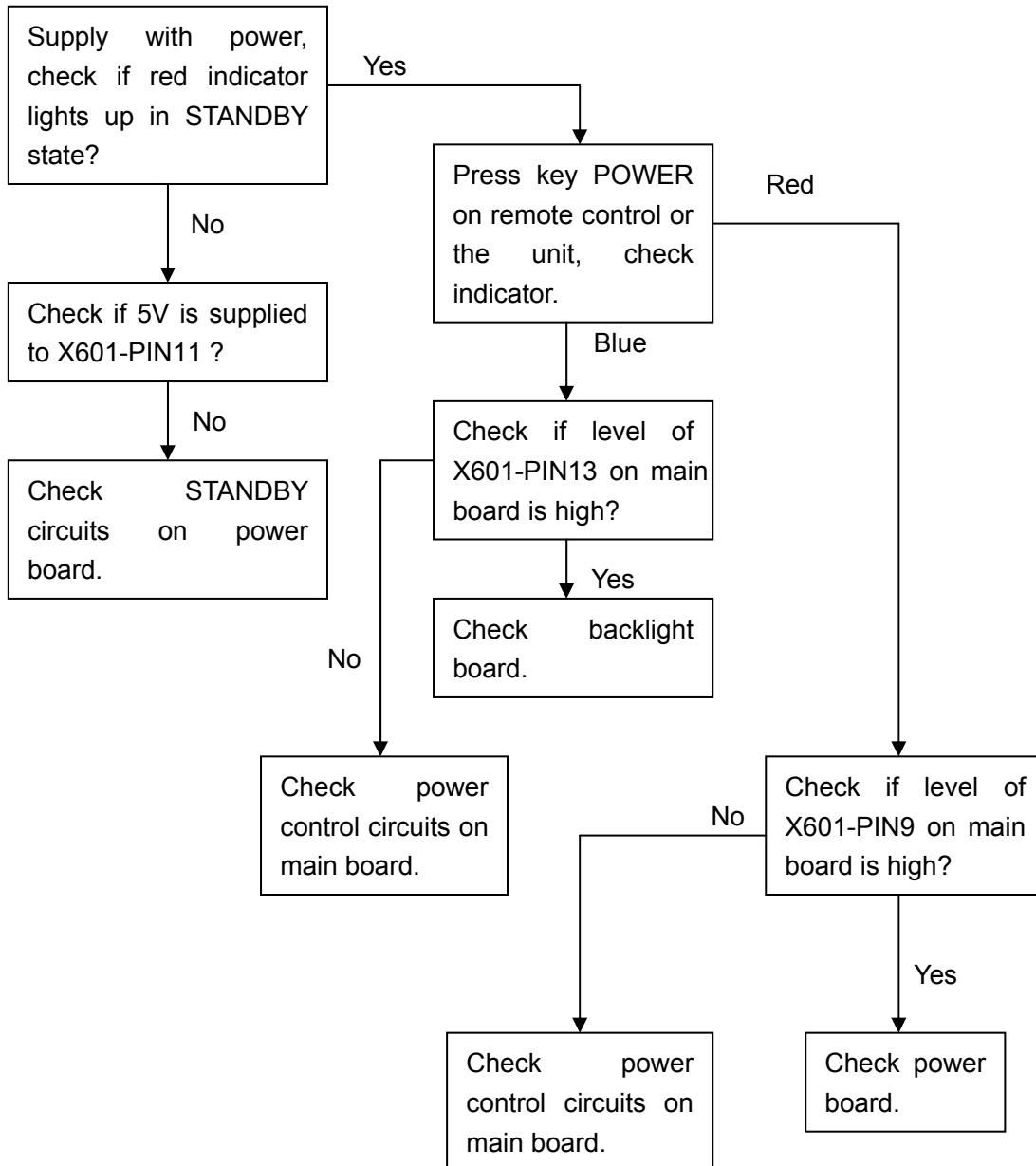

2. No picture, but backlight is normal:

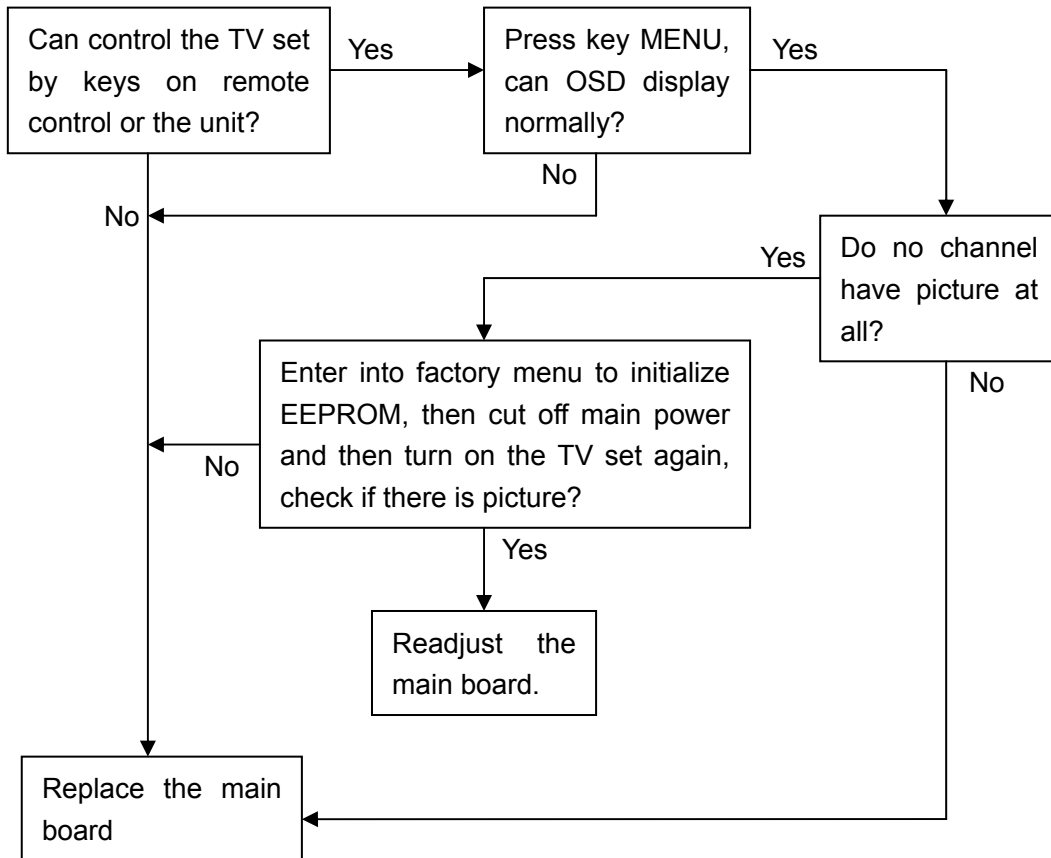

3. No sound, but picture is normal:

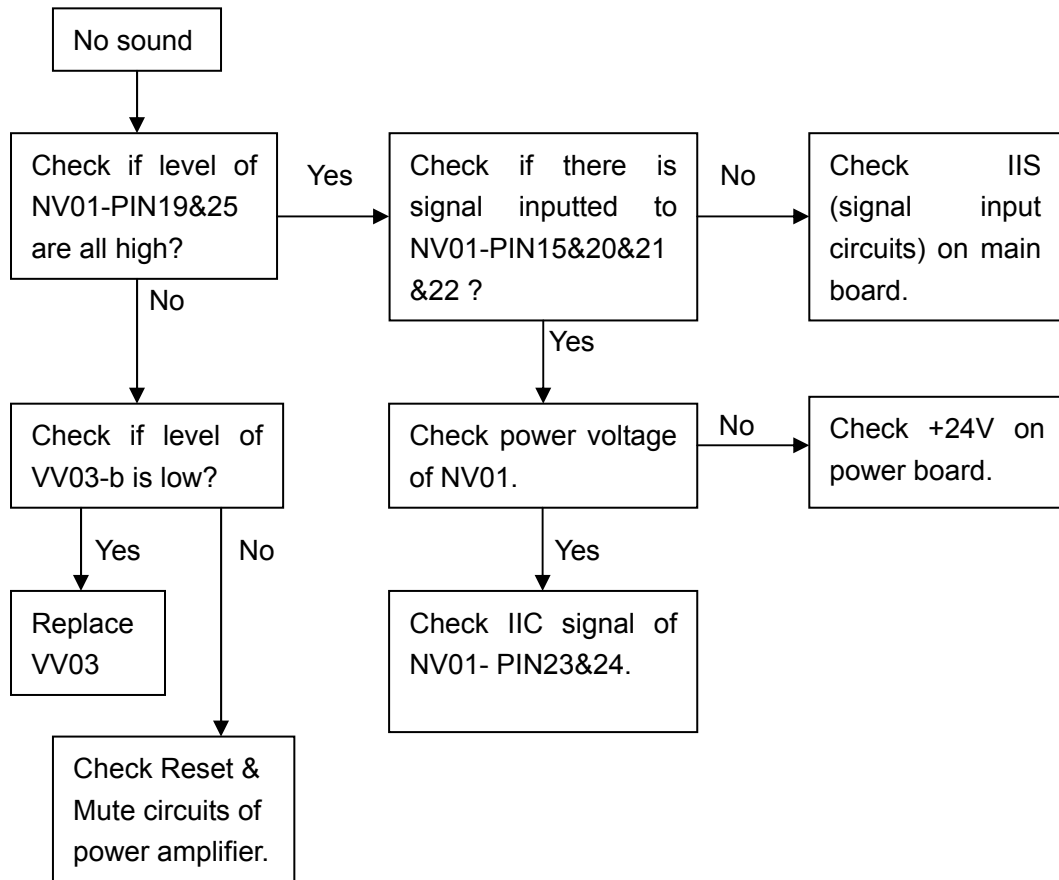



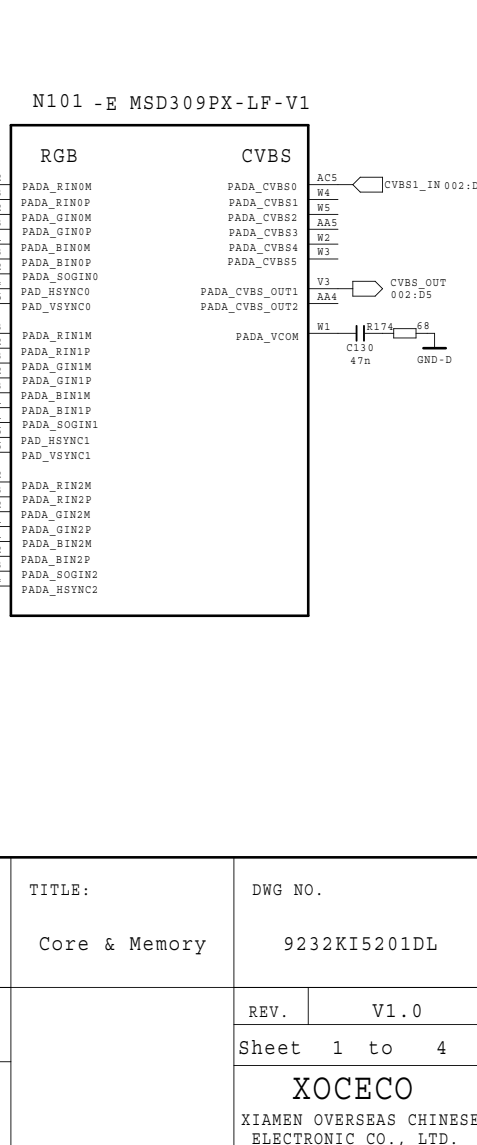
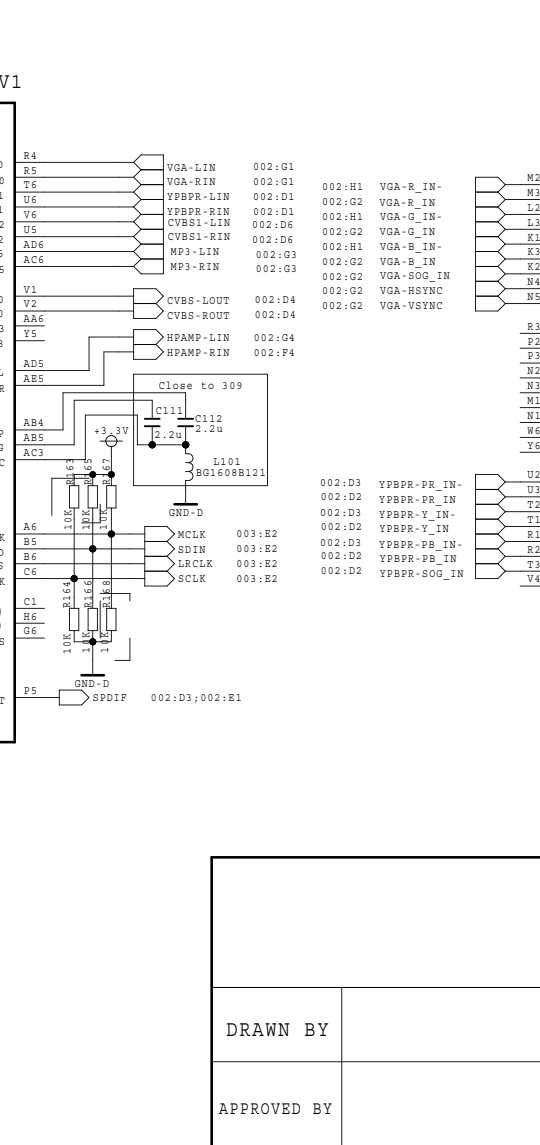
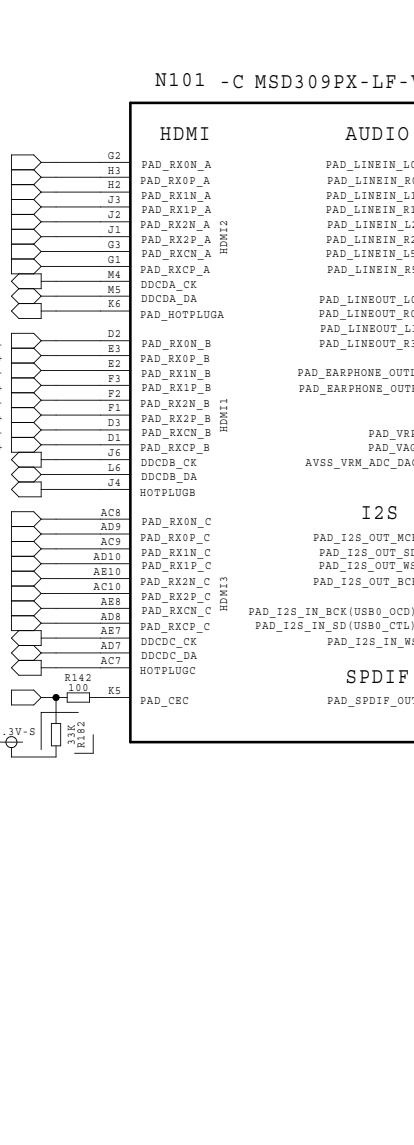
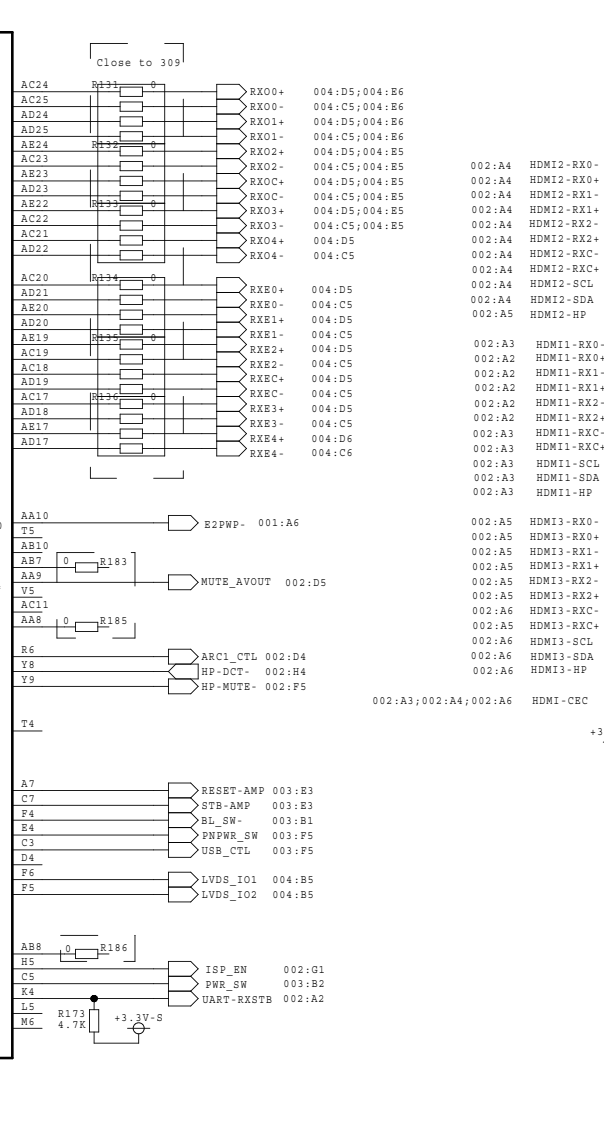
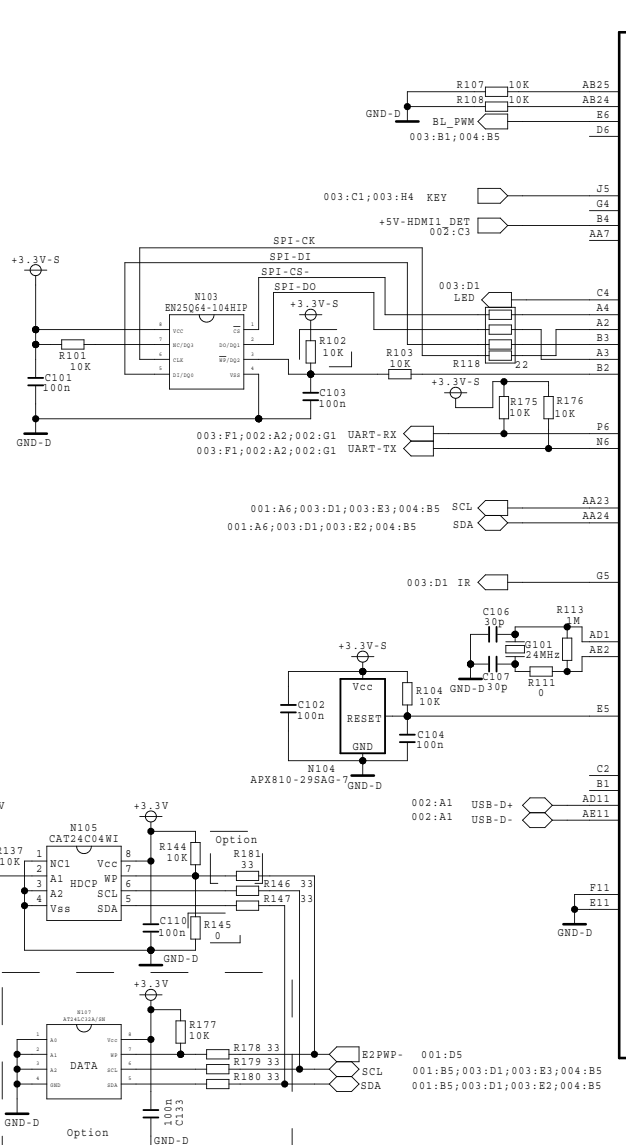
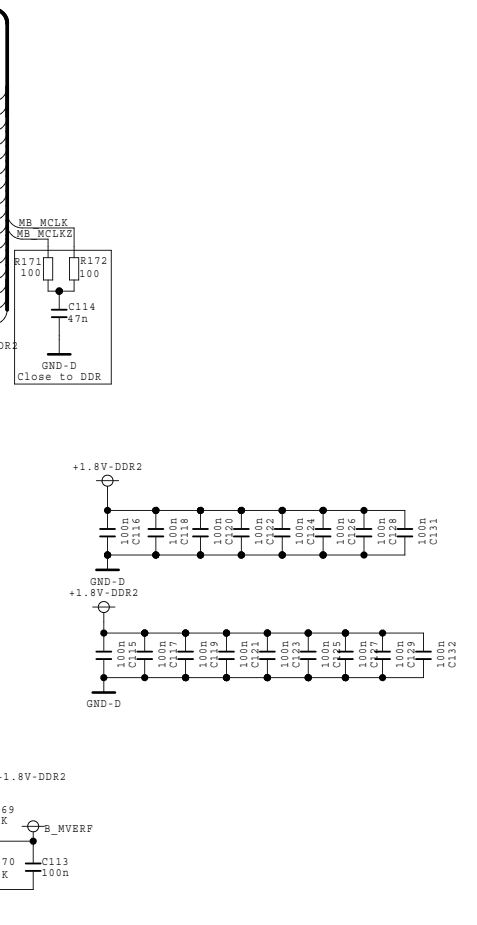
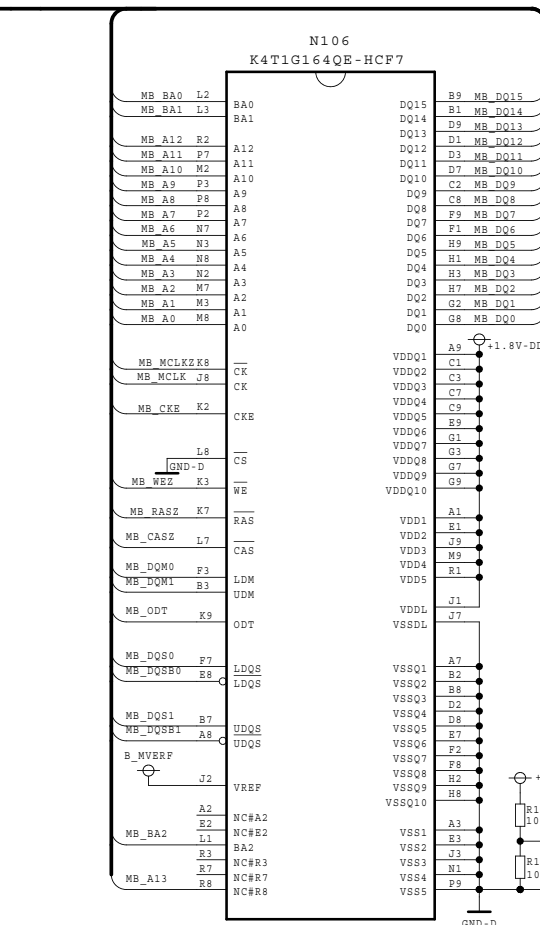
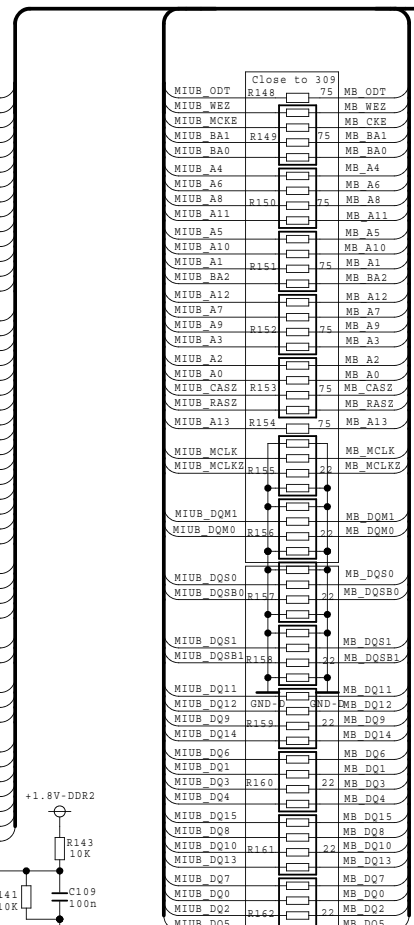
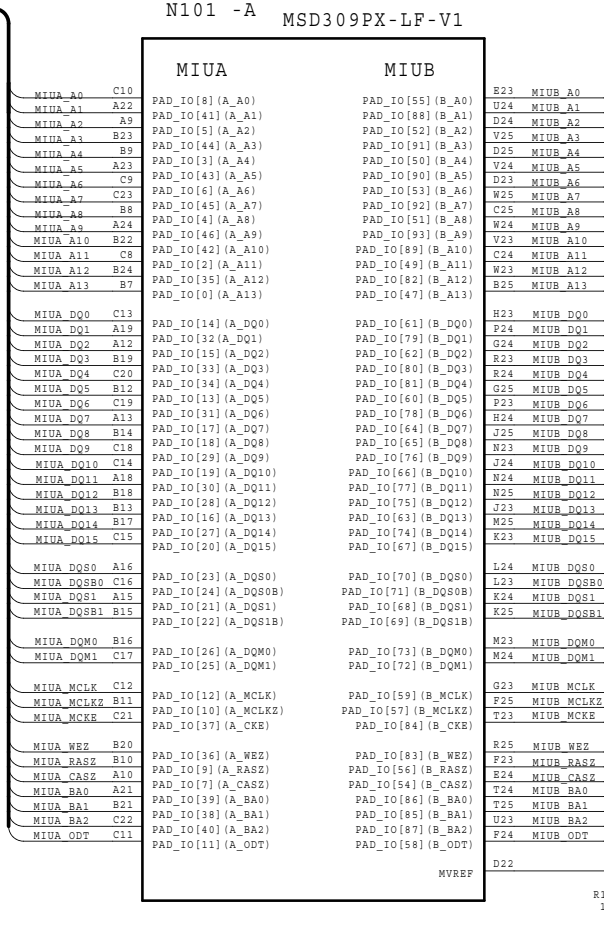
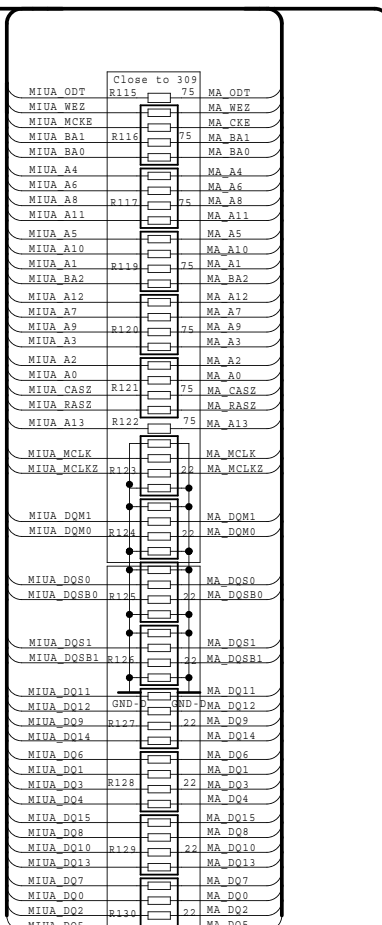
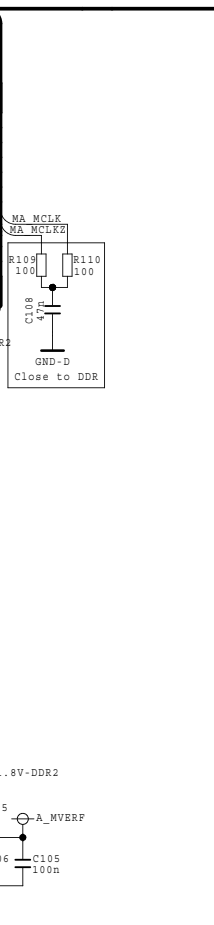
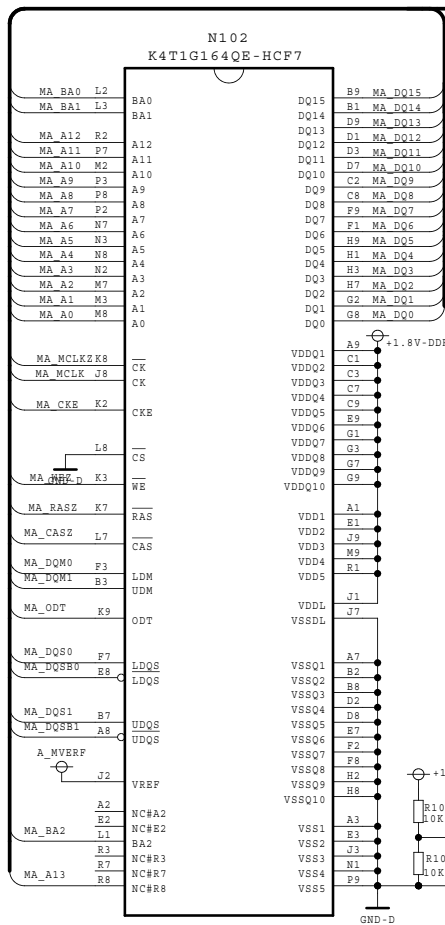

TITLE:		DWG NO.	
Core & Memory		9232KI5201DL	
REV.	V1.0		
Sheet 1 to 4			
<b>XOCECO</b>			
XIAMEN OVERSEAS CHINESE ELECTRONIC CO., LTD.			

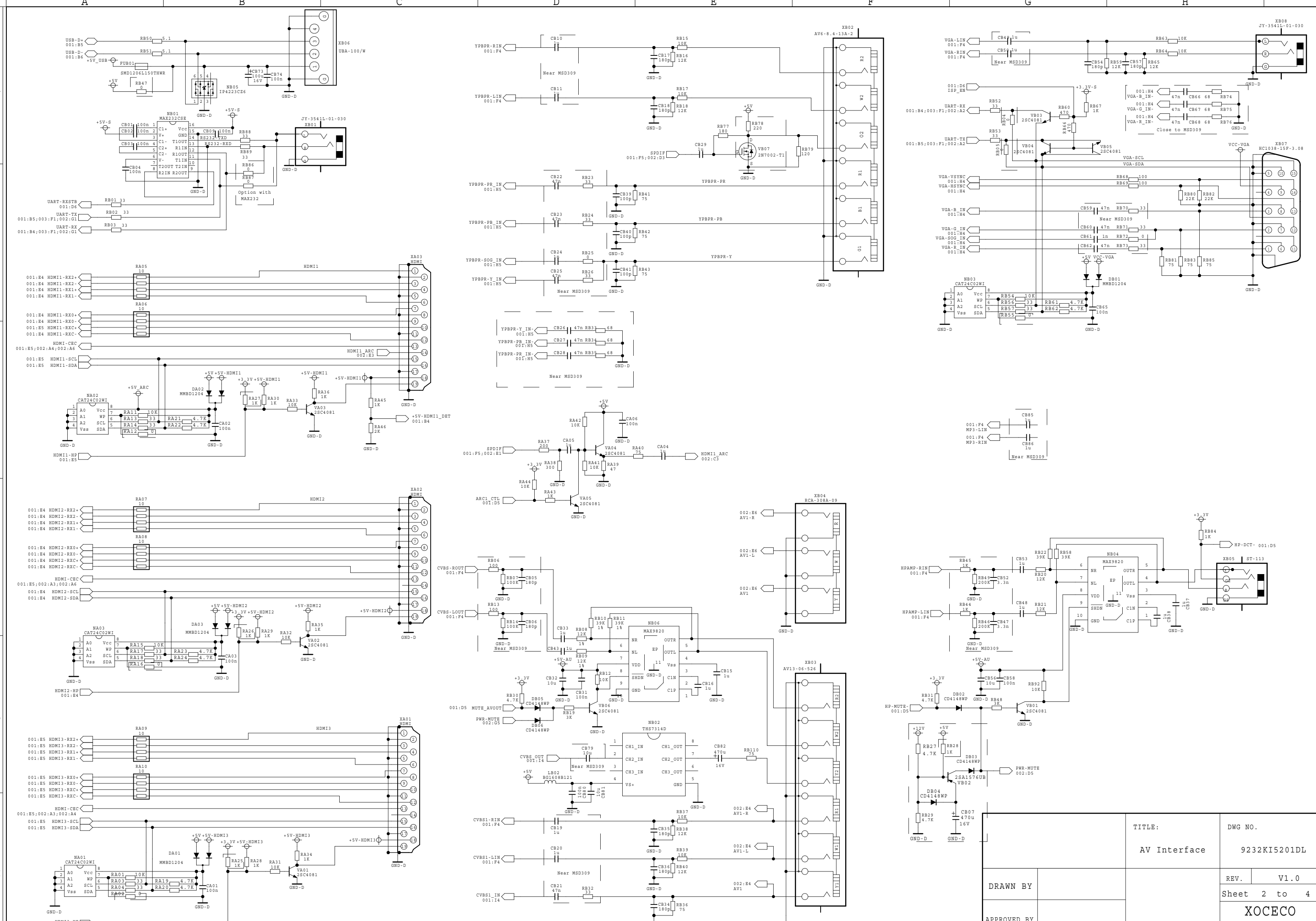

TITLE:		DWG NO.	
AV Interface		9232KI5201DL	
DRAWN BY		REV. V1.0	
APPROVED BY		Sheet 2 to 4	
<b>XOCECO</b> XIAMEN OVERSEAS CHINESE ELECTRONIC CO., LTD.			

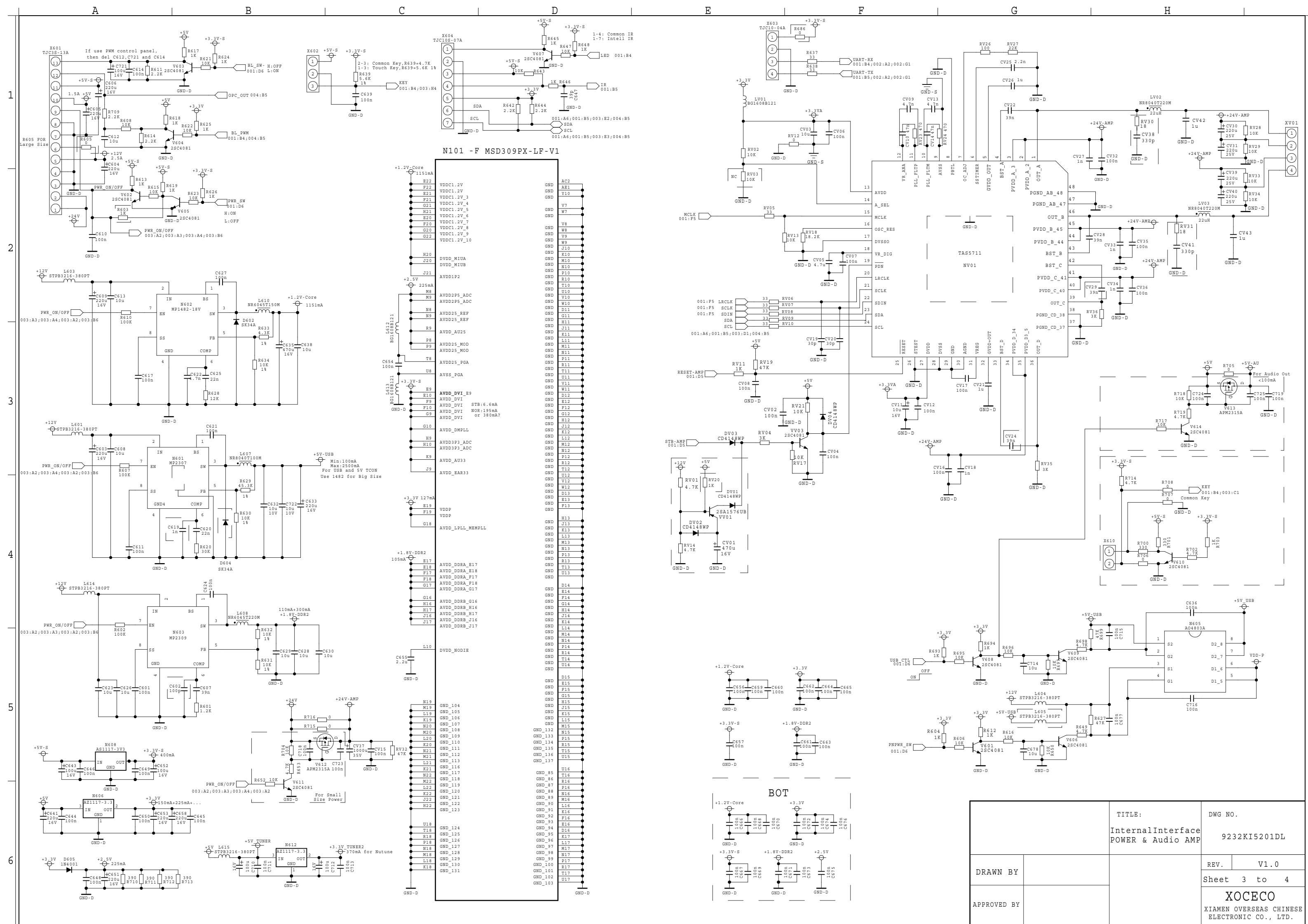

N101 -F MSD309PX-LF-V1

AC2	AVDD1_P2	AVDD2_P5_ADC	AVDD2_P5_REF	AVDD2_P5_MOD	AVDD2_P5_MOD	AVDD2_P5_PGA	AVDD_DVI_E9	AVDD_DVI	AVDD_DVI	AVDD_DVI	AVDD_DMPLL	AVDD3_P3_ADC	AVDD3_P3_ADC	AVDD_AU33	AVDD_EAR33	VDDP	VDDP	AVDD_LPPLL_MEMPLL	AVDD_DDRA_E17	AVDD_DDRA_E18	AVDD_DDRA_F17	AVDD_DDRA_F18	AVDD_DDRA_G17	AVDD_DDRB_O16	AVDD_DDRB_H16	AVDD_DDRB_H17	AVDD_DDRB_I16	AVDD_DDRB_I17	DVDD_NODDIE	GND_104	GND_105	GND_106	GND_107	GND_108	GND_109	GND_110	GND_111	GND_112	GND_113	GND_114	GND_115	GND_116	GND_117	GND_118	GND_119	GND_120	GND_121	GND_122	GND_123	GND_124	GND_125	GND_126	GND_127	GND_128	GND_129	GND_130	GND_131	GND_132	GND_133	GND_134	GND_135	GND_136	GND_137	GND_85	GND_86	GND_87	GND_88	GND_89	GND_90	GND_91	GND_92	GND_93	GND_94	GND_95	GND_96	GND_97	GND_98	GND_99	GND_100	GND_101	GND_102	GND_103											
AVDD1_2V	AVDD1_2V	AVDD1_2V_3	AVDD1_2V_4	AVDD1_2V_5	AVDD1_2V_6	AVDD1_2V_7	AVDD1_2V_8	AVDD1_2V_9	AVDD1_2V_10	DVDD_MI0A	DVDD_MI0B	AVDD1_P2	AVDD2_P5_ADC	AVDD2_P5_REF	AVDD2_P5_MOD	AVDD2_P5_MOD	AVDD2_P5_PGA	AVDD_DVI_E9	AVDD_DVI	AVDD_DVI	AVDD_DVI	AVDD_DMPLL	AVDD3_P3_ADC	AVDD3_P3_ADC	AVDD_AU33	AVDD_EAR33	VDDP	VDDP	AVDD_LPPLL_MEMPLL	AVDD_DDRA_E17	AVDD_DDRA_E18	AVDD_DDRA_F17	AVDD_DDRA_F18	AVDD_DDRA_G17	AVDD_DDRB_O16	AVDD_DDRB_H16	AVDD_DDRB_H17	AVDD_DDRB_I16	AVDD_DDRB_I17	DVDD_NODDIE	GND_104	GND_105	GND_106	GND_107	GND_108	GND_109	GND_110	GND_111	GND_112	GND_113	GND_114	GND_115	GND_116	GND_117	GND_118	GND_119	GND_120	GND_121	GND_122	GND_123	GND_124	GND_125	GND_126	GND_127	GND_128	GND_129	GND_130	GND_131	GND_132	GND_133	GND_134	GND_135	GND_136	GND_137	GND_85	GND_86	GND_87	GND_88	GND_89	GND_90	GND_91	GND_92	GND_93	GND_94	GND_95	GND_96	GND_97	GND_98	GND_99	GND_100	GND_101	GND_102	GND_103

TITLE:		DWG NO.	
InternalInterface		9232KI5201DL	
POWER & Audio AMP		REV.	V1.0
DRAWN BY		Sheet 3 to 4	
APPROVED BY		XOCECO XIAMEN OVERSEAS CHINESE ELECTRONIC CO., LTD.	

N101 -B MSD309PX-LF-V1

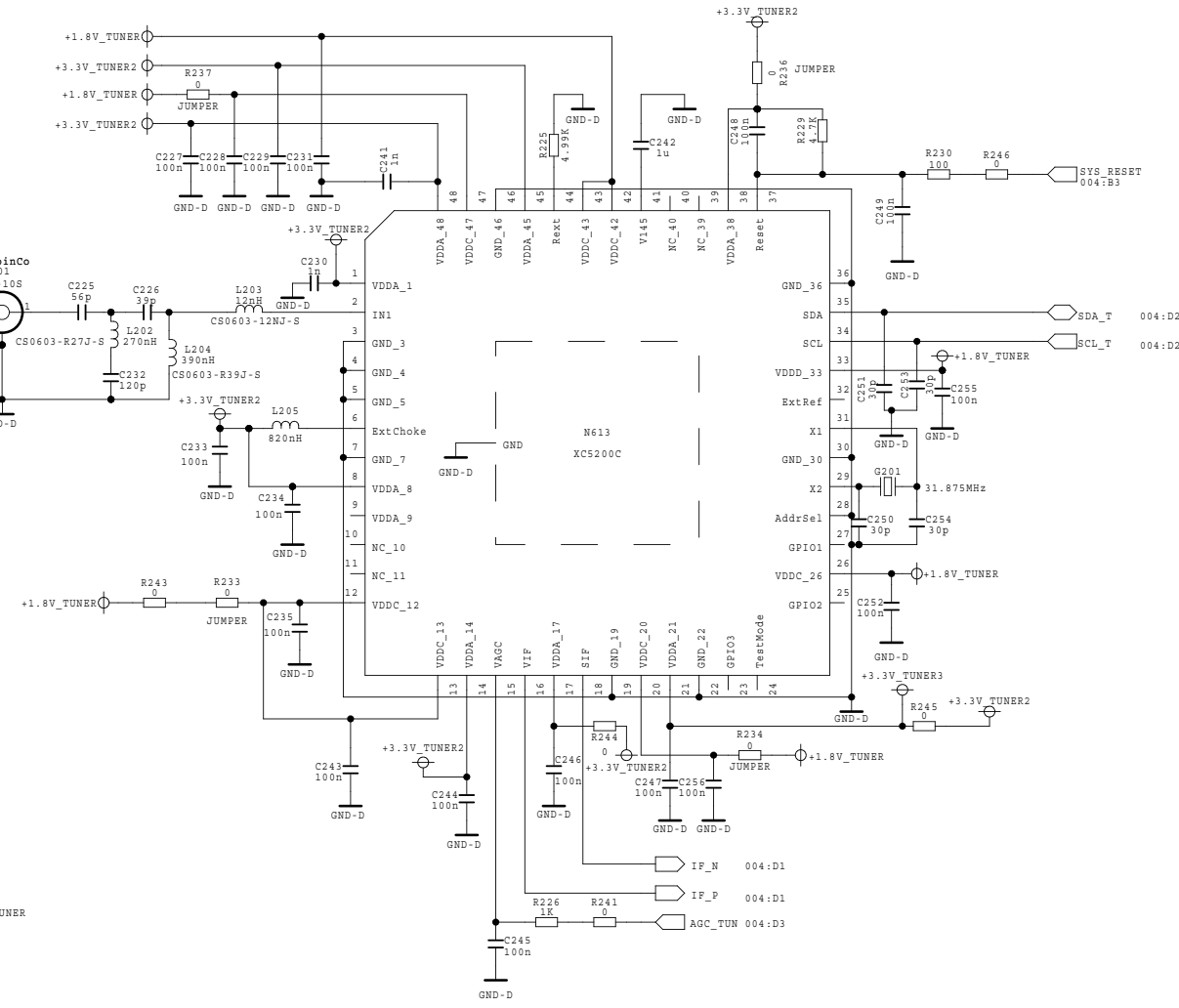
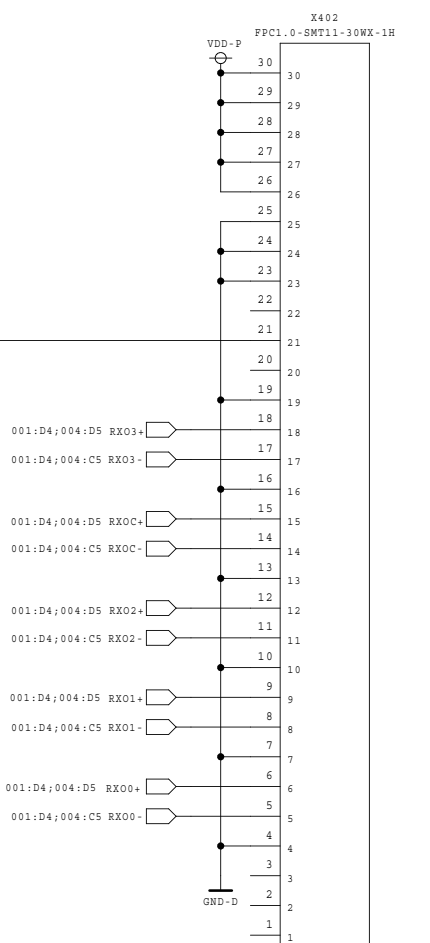
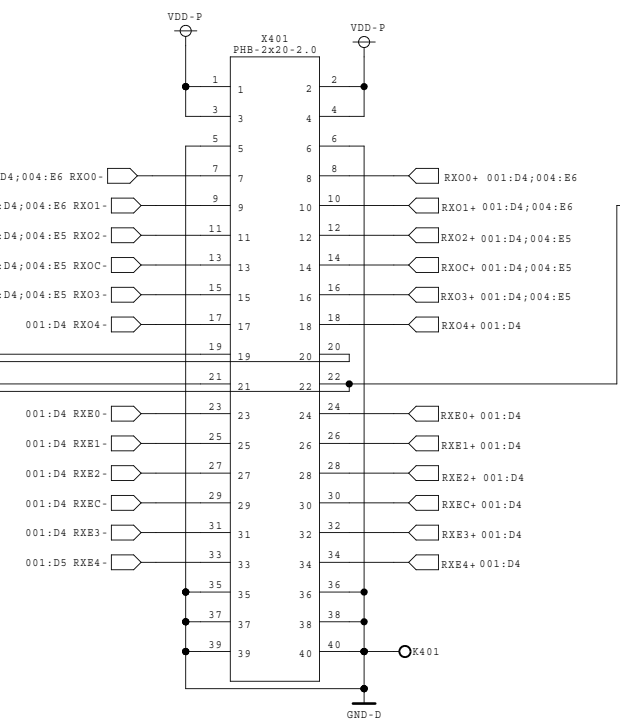
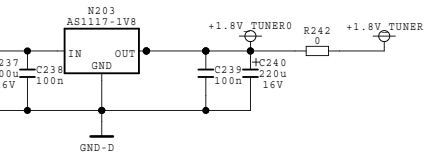
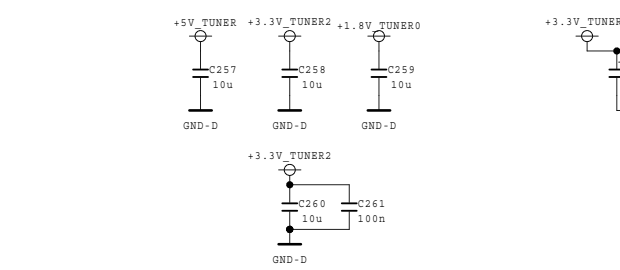
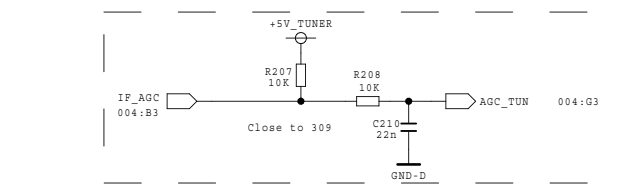
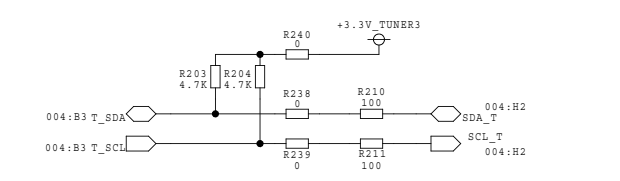
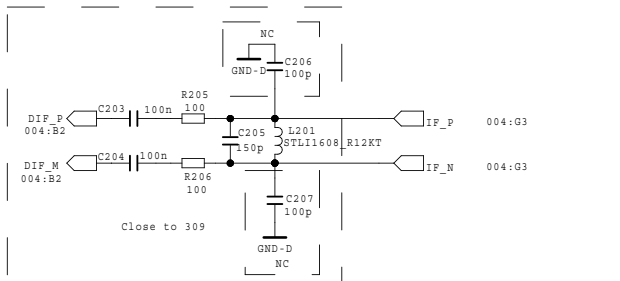
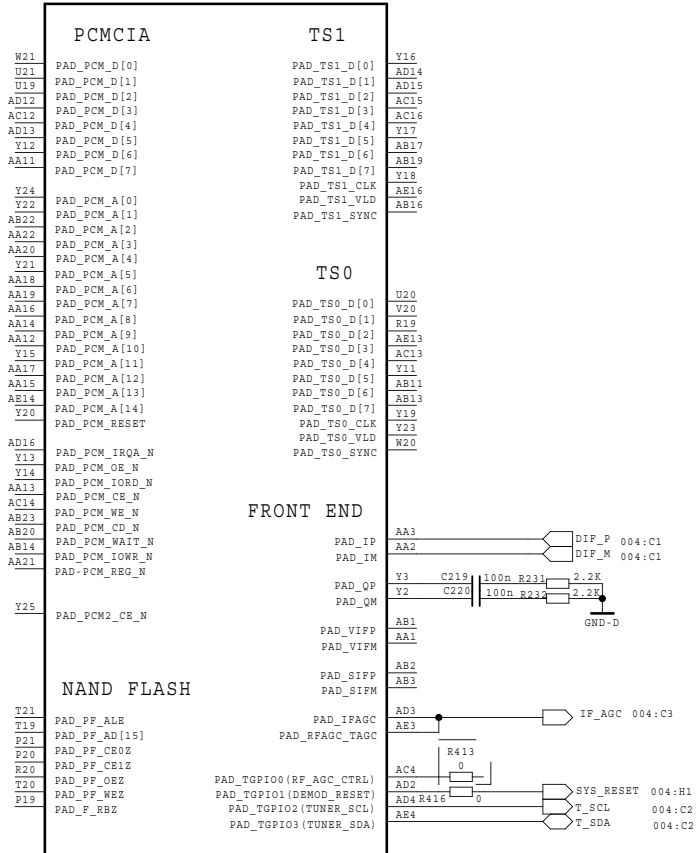

DRAWN BY		TITLE: Tuner & Demo		DWG NO. 9232KI5201DL	
APPROVED BY		REV. V1.0		Sheet 4 to 4	
		XOCECO		XIAMEN OVERSEAS CHINESE ELECTRONIC CO., LTD.	

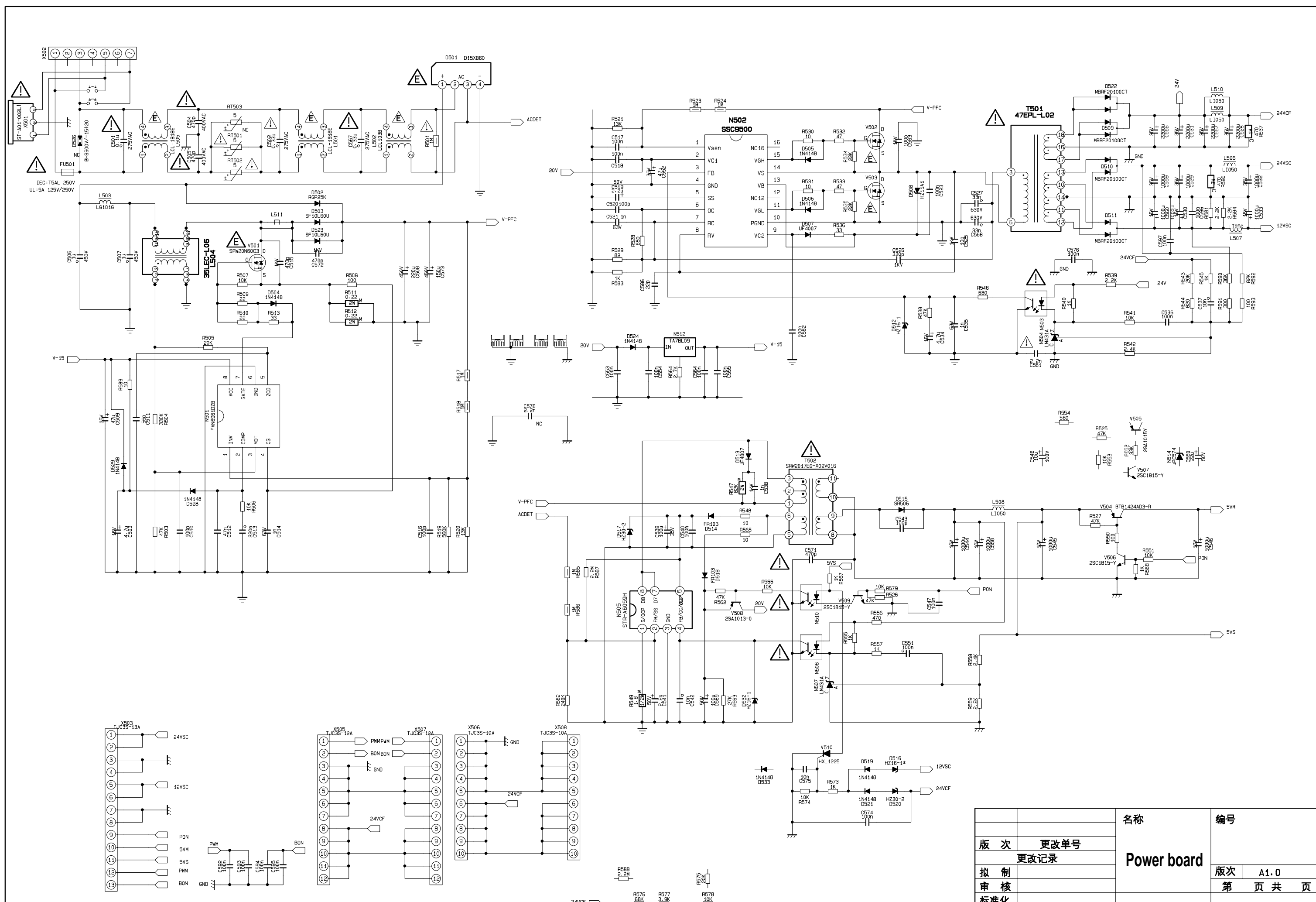

更改记录		名称	编号	
版次	更改单号		版次	编号
1.0		Power board	1.0	A1.0
			第 1 页	共 1 页
拟制		厦门华侨电子股份有限公司		
审核				
标准化				
工艺				
批准				

**APPENDIX-A: Main assembly 9246KI5213 LCD-46XR11F(B)**

<b>NAME</b>	<b>NO.</b>	<b>MAIN COMPONENT AND IT'S NO.</b>	
Main processing board	XI6KI0140110	N101 N102,N106 N613 NV01	MSD309PX-LF-SV (5270309003) NT5TU32M16DG_AC(5273216001) XC5200C (5275200002) TAS5711 ( 5275711001)
IR board	XI635KI01002		
Key board	XI635KS00401		
Power board	XI6MW0032010		
Remote control	XI6010900802	RC-908-0A (RC-S071)	
Panel	XI5203468305	T460HW08 V0	

# APPENDIX-B: Exploded view (LCD-46XR11F(B))

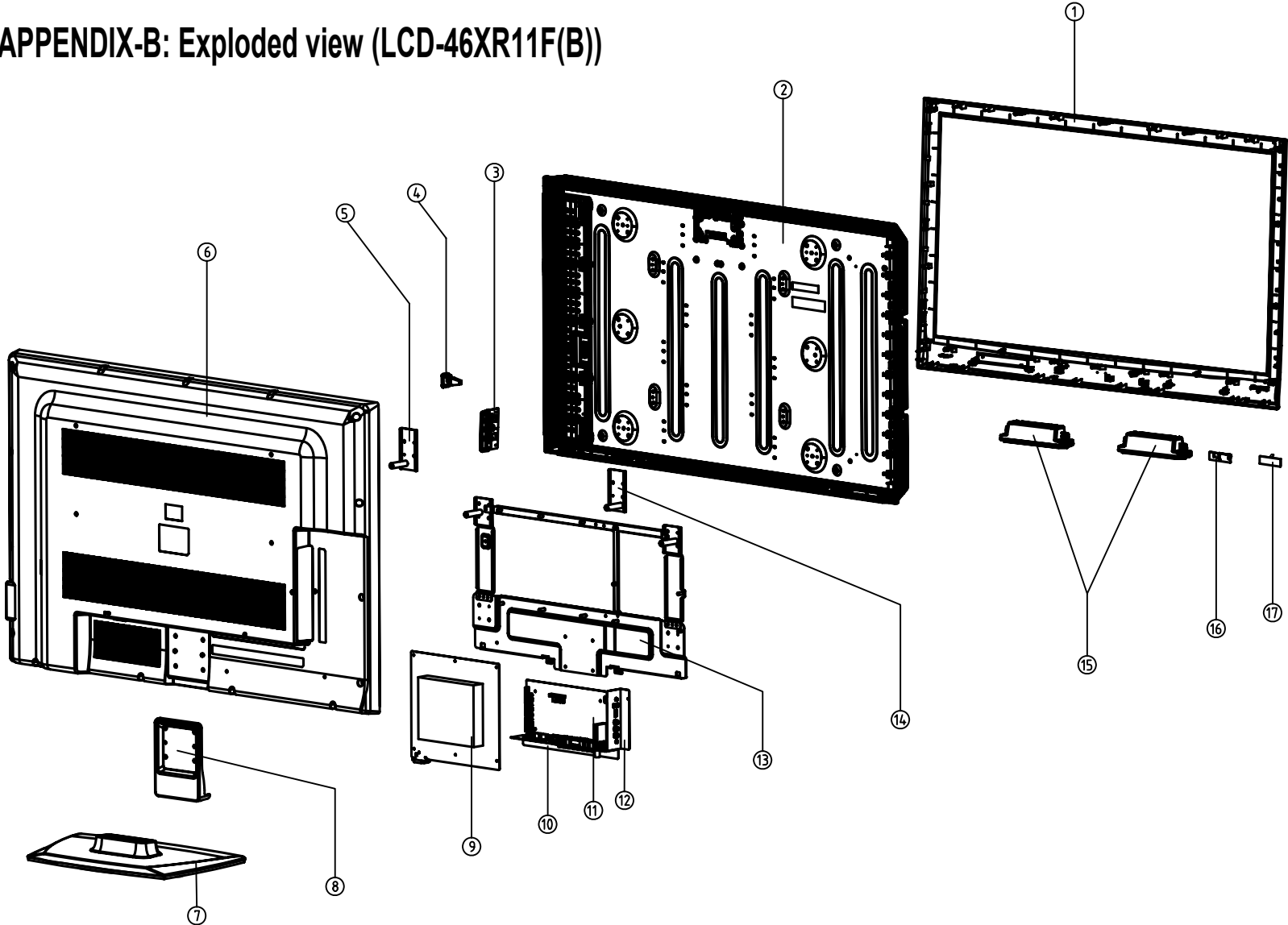

## PART LIST OF EXPLODED VIEW

REF.No.	DESCRIPTION
1	Front cabinet assembly
2	Display panel
3	Key board assembly
4	Power switch
5	Wall mounting bracket (left)
6	Back cover assembly
7	Pedestal assembly
8	Standing pole
9	Power board assembly
10	Interface baffle (down)
11	Main board assembly
12	Interface baffle (right)
13	Panel holder assembly
14	wall mounting bracket (right)
15	Speaker assembly
16	IR assembly
17	Light-guided pole

Note: Design and specification are subject to change without notice.



**PART LIST**

LCD-46XR11F(B) ver.1.0

REF.No.	PARTS No.	DESCRIPTION	Q'TY	REMARK
1	XI6646521140	Front cabinet assembly	1	
2	XI5203468305	Display panel	1	T460HW08 V0
3	XI635KS00401	Key board assembly	1	
4	XI5293000060	Power switch	1	
5	XI58A0084100	Wall mounting bracket (left)	1	
6	XI674652L110	Back cover assembly	1	
7	XI6151215000	Pedestal assembly	1	
8	XI58D0029510	Standing pole	1	
9	XI6MW0032010	Power board assembly	1	
10	XI5810V72200	Interface baffle (down)	1	
11	XI6KI0140110	Main board assembly	1	
12	XI5810P72110	Interface baffle (right)	1	
13	XI 6153363000	Panel holder assembly	1	
14	XI58A0084200	wall mounting bracket (right)	1	
15	XI6170835000	Speaker assembly	1	
16	XI635KI01002	IR assembly	1	
17	XI570031901D	Light-guided pole	1	
18	XI6010900802	Remote control	1	
19	XI5944039750	User manual	1	
20	XI60Z0000751	Backlight board	1	
21	XI60Z0000752	Logical board	1	

- Only the parts in above list are used for repairing.
- Other parts except the above parts can't be supplied.

## Appendix: Installing the Stand

If the stand is provided, please read these instructions thoroughly before attempting this installation.

You must install your TV into the stand in order for it to stand upright on a cabinet or other flat surface. If you intend to mount your TV on a wall or other vertical surface, you must remove the stand column.

### Cautions:

Make sure that you handle your TV very carefully when attempting assembly or removal of the stand. If you are not sure of your ability to do this, or of your ability to use the tools necessary to complete this job, refer to a professional installer or service personnel. The manufacturer is not responsible for any damages or injuries that occur due to mishandling or improper assembly.

When using a table or bench as an aid to assembly, make sure that you put down a soft cushion or covering to prevent accidental scratching or damage to your TV's finish.

The speaker is not intended to support the weight of your TV. Do not move or handle your TV by the speaker. This can cause damage to your TV that is not covered by the manufacturer's warranty.

Before attempting assembly or removal of the stand, unplug the AC power cord.

### Installing the stand

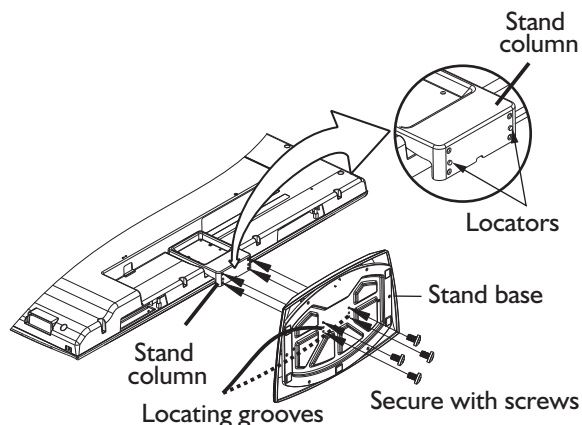

### To install the stand:

1. Remove the stand from the box and place it on a table or bench.

You must pay attention to the direction of the stand. The wide portion of the stand should go towards the front of the TV.

2. Lay your TV flat (screen down) on the edge of a table or bench. Make sure that you put down a soft cushion or cloth so that your TV is not scratched.
3. Align the stand base with the TV, move the stand base gently until the locators on the stand column align with the locating grooves on the stand. And align the holes in the stand with the holes in the stand column, then secure the stand to the column with provided screws.

To remove the stand from the TV, just detach the screws from the stand base.

### NOTE:

The appearance of this product in these illustrations may differ from your actual product, and is for comparative purposes only.

# WALL MOUNTING INSTRUCTIONS

## ⚠ Safety Precautions:

1. Be sure to ask an authorized service personnel to carry out setup.
2. Thoroughly read this instruction before setup and follow the steps below precisely.
3. The wall to be mounted should be made from solid materials. Only use accessories supplied by the manufacturer.
4. Very carefully handle the unit during setup. We are not liable for any damage or injury caused by mishandling or improper installation.
5. Be sure to place the unit on a stable and soft platform which is strong enough to support the unit.
6. Do not uplift the speaker when moving the display. The appearance of the unit may differ from the actual ones.
7. Design and specifications are subject to change without notice.
8. Retain these instructions for future reference.

**Note: All the wall mounting parts are optional and may be unavailable in your model.**

Below we will show you how to mount the Display on the wall using our company's wall mounting components.

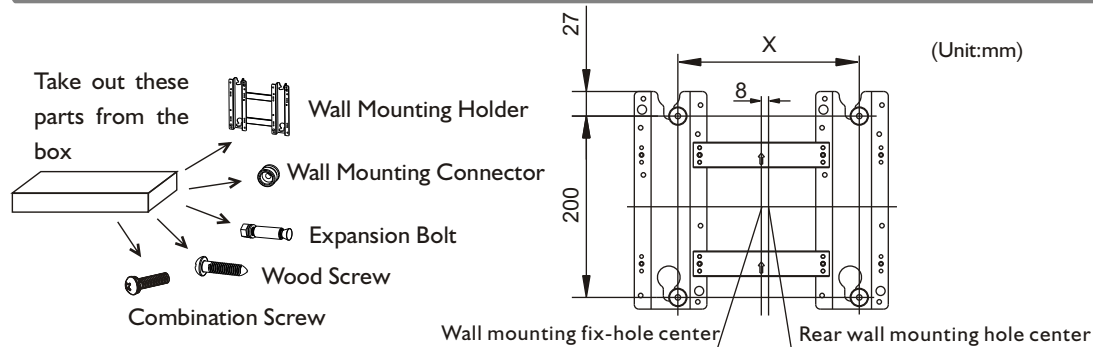

Fig. 1

1. There are three options of wall mounting holder with different specifications :200200,200400,200600. Please check your wall mounting holder for its specification.

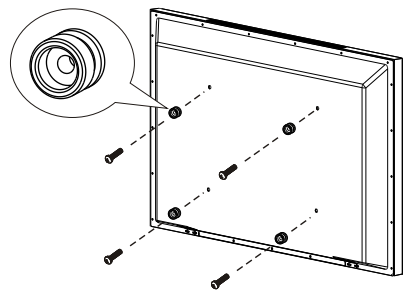

Fig. 4

4. Use the 4pcs combination screws to fix the wall mounting connector to the rear of the display unit.(Caution:the direction of the connectors should be strictly confirm to the diagram illustrated above).

2. Due to the wall mounting fix-groove leaning to the right side, the whole unit will lean to right side after installation, please carefully measure the position of the holes you want to drill, refer to the parameters on Fig.2 when drilling the holes.

Note: The "X" in Fig.2 represents a data. It may be 200mm or 400mm or 600mm.

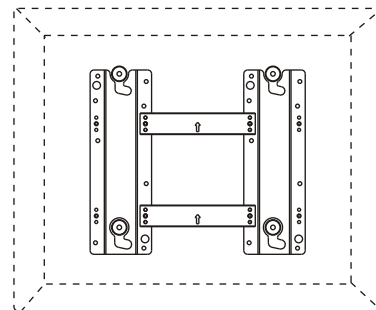

Fig. 5

5. Put the back of the display unit close to the wall mounting holder, insert the four wall mounting connectors into the four calabash-shaped holes on the wall mounting holder. (Fig.5)

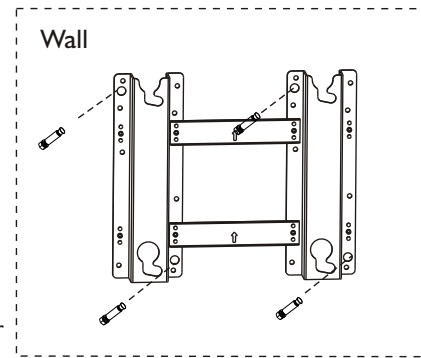

Fig.3a

- 3a. Screw 4pcs expansion bolts to fix the wall mounting holder on the wall.

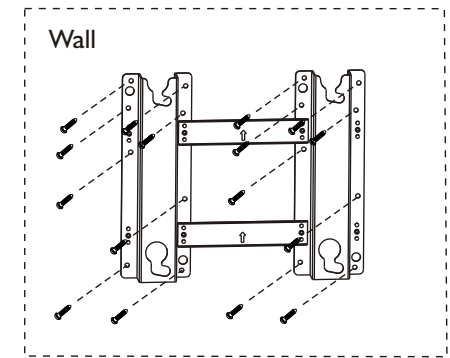

Fig.3b

- 3b. If your wall is a wooden structure, please fix the wall mounting holder on the wall with 6pcs wood screws.

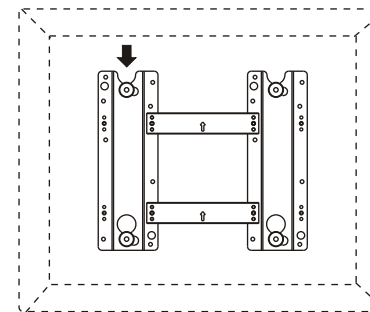

Fig. 6

6. Let the display unit slowly slide down to the end of the calabash-shaped hole. (Fig.6)

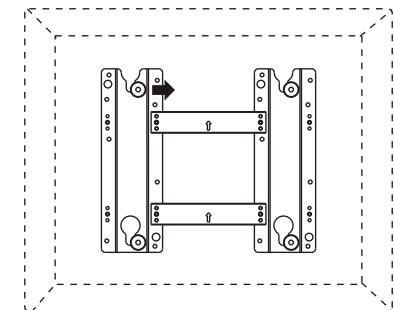

Fig. 7

7. Push rightwards carefully until the wall mounting connectors fully slide into the right fix-grooves and be sure the mounting is secure.

8. If you want to dismount the unit do the above steps in reverse order.



September 2011

SANYO Electric Co., Ltd.