



## 样品承认书

LCD-T0354001

**This module uses RoHS material**

CUSTOMER	
Project NUMBER	
CUSTOMER APPROVAL	
DATE	
Comment	

DEPARTMENT	NAME	SIGNATURE	DATE
DESIGN			
CHECK			
APPROVE			





## Specification of LCD-T0354001

### 1. General Description:

The **LCD-T0354001** model is a-si active matrix TFT display module without Touch panel. This module has 3.5inch diagonally measured active area with 320 Horizontal by 480 vertical pixel array and this module can display 262K color.

### 2. General Feature:

Item	Contents	Unit
LCD Type	TFT transmissive, Normally white	/
Viewing direction	6 O'clock	O'clock
Outline dimensions	54.66 (W) X82.94(H)X2.3(T)	mm
Active area	48.96(W) x 73.44(H)	mm
Number of Pixels	320(H) x (R.G.B.) x480(W)	Dot
Driver IC	ILL9488 s6d05a1	/
Colors	262K	K
Backlight type	LED	/
TP	NC	/
Interface Type	8080 system 8/16 bit parallel DEFAULT 16BIT	
Weight	T.B.D.	g



### 3. Block diagram

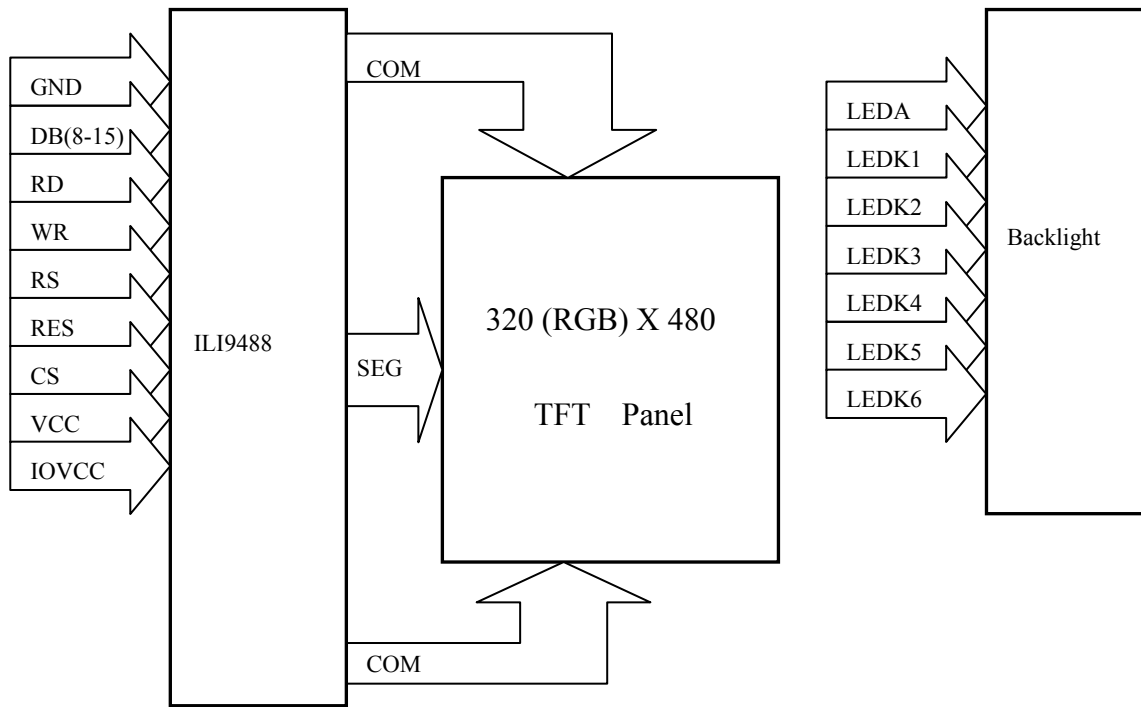

1	2	3	4	5	6	7	8
TITLE			???	SCALE 1 : 1		UNIT	mm
Part no			PAGE 1 / 1		EDITION		A0

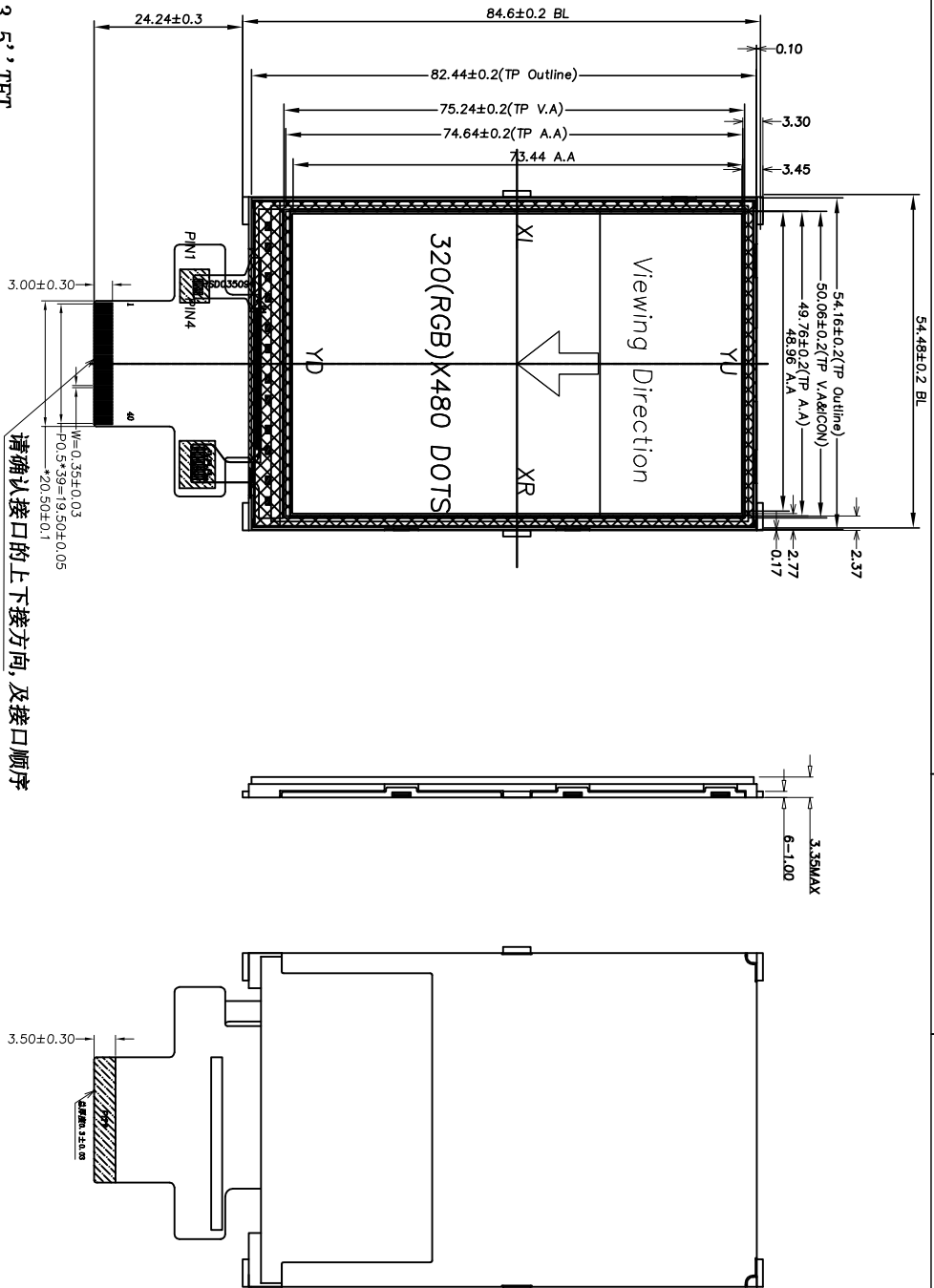

No.	Symbol	D
1	GND	
2	VCI	
3	LOWCC	
4	CSX	
5	D/CX	
6	WRX	
7	RD	
8	RESF1	
9	DB0	
10	DB1	
11	DB2	
12	DB3	
13	DB4	
14	DB5	
15	DB6	
16	DB7	
17	DB8	
18	DB9	
19	DB10	
20	DB11	
21	DB12	
22	DB13	
23	DB14	
24	DB15	
25	GND	
26	YU	
27	XI	
28	YD	
29	XR	
30	K1	
31	K2	
32	K3	
33	K4	
34	K5	
35	LEDA	
36	LEDA	
37	GND	
38	NC	
39	NC	
40	NC	

- 技术要求:
- 1) 液晶显示模式: 3.5" TFT
  - 2) 视角: 12 0' CLOCK
  - 3) 点阵: 320 (RGB) X 480 DOTS
  - 4) 驱动芯片型号: IL19488
  - 5) 背光: LED WHITE (X4), 并联
  - 6) 工作温度: -20° C-----70° C
  - 7) 未注尺寸公差: ±0.2mm
  - 8) 产品符合: ROHS标准

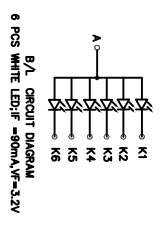

ANGLE	±1.0°
60.01 - 120.00	±0.3
30.01 - 60.00	±0.2
0.00 - 30.00	±0.15

FIELD	TOLERANCE	RE (备注)	DATE (日期)	DESCRIPTION (描述)

1	2	3	4	5	6	7	8
??/??	??/??	??/??	??/??	??/??	??/??	??/??	第三角

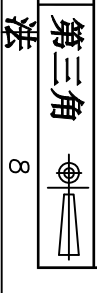



此液晶产品支持三种接口模式：mcu8位，mcu16位，四线spi

接线原理图如下：

FPC\_16BIT

GND	1	GND
VDD	2	VCI
VDD	3	VCI
CS	4	CS
RS	5	RS
WR	6	WR
RD	7	RD
RESET	8	RESET
DB0	9	DB0
DB1	10	DB1
DB2	11	DB2
DB3	12	DB3
DB4	13	DB4
DB5	14	DB5
DB6	15	DB6
DB7	16	DB7
DB8	17	DB8
DB9	18	DB9
DB10	19	DB10
DB11	20	DB11
DB12	21	DB12
DB13	22	DB13
DB14	23	DB14
DB15	24	DB15
GND	25	GND
Y-	26	YU
X-	27	XL
Y+	28	YD
X+	29	XR
LEDK	30	LEDK
LEDK	31	
LEDK	32	
LEDK	33	
LEDK	34	
LEDA	35	LEDKA
LEDA	36	LEDKA
GND	37	GND
NC	38	×
NC	39	×
NC	40	×

16BIT R4 R2

FPC\_8BIT

GND	1	GND
VDD	2	VCI
VDD	3	VCI
CS	4	CS
RS	5	RS
WR	6	WR
RD	7	RD
RESET	8	RESET
DB0	9	DB0
DB1	10	DB1
DB2	11	DB2
DB3	12	DB3
DB4	13	DB4
DB5	14	DB5
DB6	15	DB6
DB7	16	DB7
DB8	17	
DB9	18	
DB10	19	
DB11	20	
DB12	21	
DB13	22	
DB14	23	
DB15	24	
GND	25	GND
Y-	26	YU
X-	27	XL
Y+	28	YD
X+	29	XR
LEDK	30	LEDK
LEDK	31	
LEDK	32	
LEDK	33	
LEDK	34	
LEDA	35	LEDKA
LEDA	36	LEDKA
GND	37	GND
NC	38	×
NC	39	×
NC	40	×

8BIT R4 R1

FPC\_SPI

GND	1	GND
VDD	2	VCI
VDD	3	VCI
CS	4	CS
RS	5	RS
WR	6	SCL
RD	7	VCI
RESET	8	RESET
DB0	9	
DB1	10	
DB2	11	
DB3	12	
DB4	13	
DB5	14	
DB6	15	
DB7	16	
DB8	17	
DB9	18	
DB10	19	
DB11	20	
DB12	21	
DB13	22	
DB14	23	
DB15	24	
GND	25	GND
Y-	26	YU
X-	27	XL
Y+	28	YD
X+	29	XR
LEDK	30	LEDK
LEDK	31	
LEDK	32	
LEDK	33	
LEDK	34	
LEDA	35	LEDKA
LEDA	36	LEDKA
GND	37	GND
NC	38	×
NC	39	×
NC	40	×

SPI R3 R1

注：R\* 代表电阻编号，标注在液晶fpc背后，使用何种接口，请做实验时进行跳位，批量出货时，会根据客户需求调整测试好。



## 5. ELECTRICAL CHARACTERISTICS:

### DC CHARACTERISTICS

Parameter	Symbol	Min	TYP	Max	Unit
Supply voltage	VCC-VSS	2.7	2.8	2.9	V
Input Current	I <sub>dd</sub>		TBD	TBD	mA
Input voltage H level	V <sub>IH</sub>	0.8V <sub>cc</sub>	V <sub>cc</sub>	V <sub>cc</sub>	V
Input voltage L level	V <sub>IL</sub>	0	0	0.2V <sub>cc</sub>	V
Output voltage H level	V <sub>OH</sub>	0.8V <sub>cc</sub>	V <sub>cc</sub>	V <sub>cc</sub>	V
Output voltage L level	V <sub>OL</sub>	0	0	0.2V <sub>cc</sub>	V

### Backlight CHARACTERISTICS (IF = 45)

Parameter	Symbol	Min	TYP	Max	Unit
Forward voltage	V <sub>f</sub>	3.0	3.2	3.4	V
Luminance(white display)	L <sub>v</sub>	-	-	-	Cd/m <sup>2</sup>
Brightness uniformity(white display)	B <sub>u</sub>	80			%
Number of LED			5		piece
Connection mode			Parallel		

## 6. ABSOLUTE MAXIMUM RATINGS:

Parameter	Symbol	Min	Max	Unit
Supply voltage	VCC	-0.3	3.3	V
Input	V <sub>in</sub>	-0.3	V <sub>cc</sub> +0.3	V
Operating temperature	T <sub>op</sub>	-10	60	°C
Storage temperature	T <sub>st</sub>	-20	70	°C
Humidity	RH	-	90%(Max60°C)	Dot
Backlight Current	I <sub>BL</sub>	-	15	mA(each Led)





## 7. Timing Characteristics

### 7.1 80-system bus interface operation

Ta = -20 °C to +70 °C, VCC = 2.80V, GND=0V.

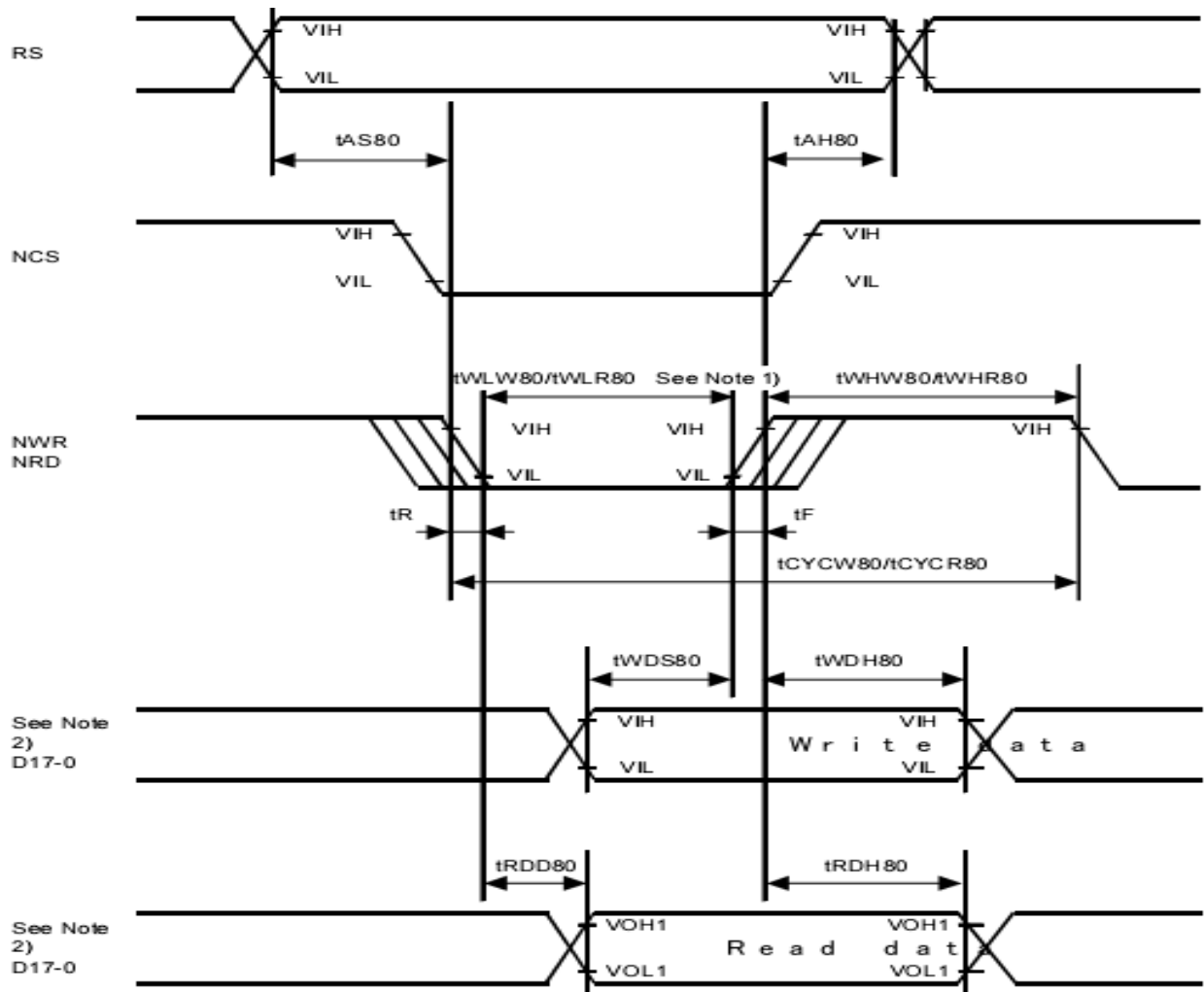

Note 1) PWLW and PWLR are defined by the overlap period when NCS is "Low" and NWR or NRD is "Low".

Note 2) Unused data input pins must be fixed at either "IOVCC" or "GND".

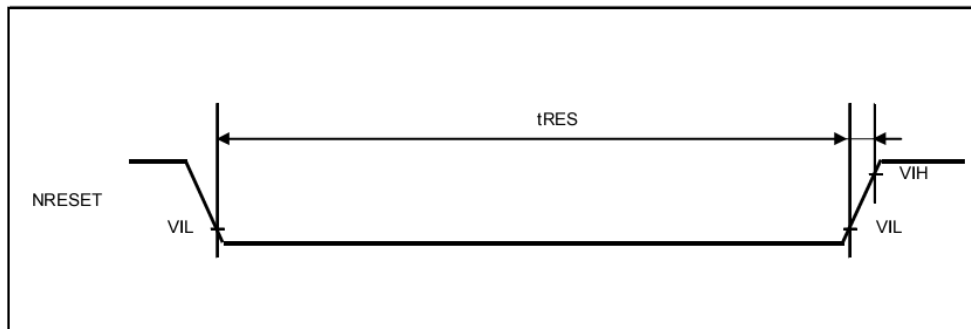

Figure 3: 80-system bus interface operation

Item		Symbol	Unit	Min	Typ	Max
Cycle time	Write	tCYCW80	ns	100 †	-	-
	Read	tCYCR80		500	-	-
Pulse width low	Write	tWLW80	ns	40	-	-
	Read "Low" level pulse width	tWLR80		250	-	-
Pulse width high	Write	tVHW80	ns	40	-	-
	Read "High" level pulse width	tVHR80		200	-	-
Pulse rise/fall time		tR, tF	ns	-	-	25
RW,RS and CSB setup time		tAS80	ns	10	-	-
RW,RS and CSB hold time		tAH80		0	-	-
			ns	2	-	-
Write data setup time		tWOS80	ns	60	-	-
Write data hold time		tWDH80	ns	15	-	-
Read data delay time		tRDD80	ns	-	-	200
Read data hold time		tRDH80	ns	5	-	-

Note \*1) If you set the horizontal dot's number "odd", the Min of tCYCW will be 200nS

## 7.2 Resetting



Item	Symbol	Unit	Min	Typ	Max
NRESET "Low" level width	tRES	μs	1	-	-
NRESET rise time	trRES	ns	-	-	10



## 8. Electro-Optical characteristics .

Optical characteristics are determined after the unit has been 'ON' and stable for approximately 30 minutes in a dark environment at 25°C. The values specified are at an approximate distance 50cm from the TFT-LCD surface at a viewing angle of  $\Phi$  and  $\theta$  equal to 0° .

Measurement condition: Refer to next pages (C-light source, Halogen Lamp)

(Ta=25 ±2°C,VDD=2.8V,IB=15mA)

Item	Symbol	Condition	Min	Typ	Max	Unit	
Contrast ratio (Center point)	C/R		450	500	-	-	
Response Time	Rising: Tr	Tr	-	2	4	msec	
	Falling: Tf	Tf	-	6	12		
Color Chromaticity (CIE 1931)	White	Wx	Note1 B/L On	0.283	0.303	0.323	-
		Wy		0.305	0.325	0.345	
	Red	Rx		0.606	0.626	0.646	
		Ry		0.314	0.334	0.354	
	Green	Gx		0.257	0.277	0.297	
		Gy		0.529	0.549	0.569	
	Blue	Bx		0.122	0.142	0.162	
		By		0.102	0.122	0.142	
Viewing angle	Hor	$\theta$ L1	C/R ≥ 10 B/L On	35	45	-	Deg.
		$\theta$ R1		35	45	-	
	Ver	$\phi$ U1		35	45	-	
		$\phi$ D1		10	20	-	

Notes : 1. Contrast Ratio(CR) is defined mathematically as :

$$\text{Contrast Ratio} = \frac{\text{Surface Luminance with all white pixels}}{\text{Surface Luminance with all black pixels}}$$

- Surface luminance is the center point across the TFT-LCD surface 500mm from the surface with all pixels displaying white. For more information see FIG 1.
- Response time is the time required for the display to transition from white to black(Rise Time, Tr) and from black to white(Falling Time, Tf). For additional information see FIG 3.
- Viewing angle is the angle at which the contrast ratio is greater than 10. The angles are determined for the horizontal or x axis and the vertical or y axis with respect to the z axis which is normal to the TFT-LCD surface. For more information see FIG 5.



FIG. 1 Optical Characteristic Measurement Equipment and Method

LCD-7000 System

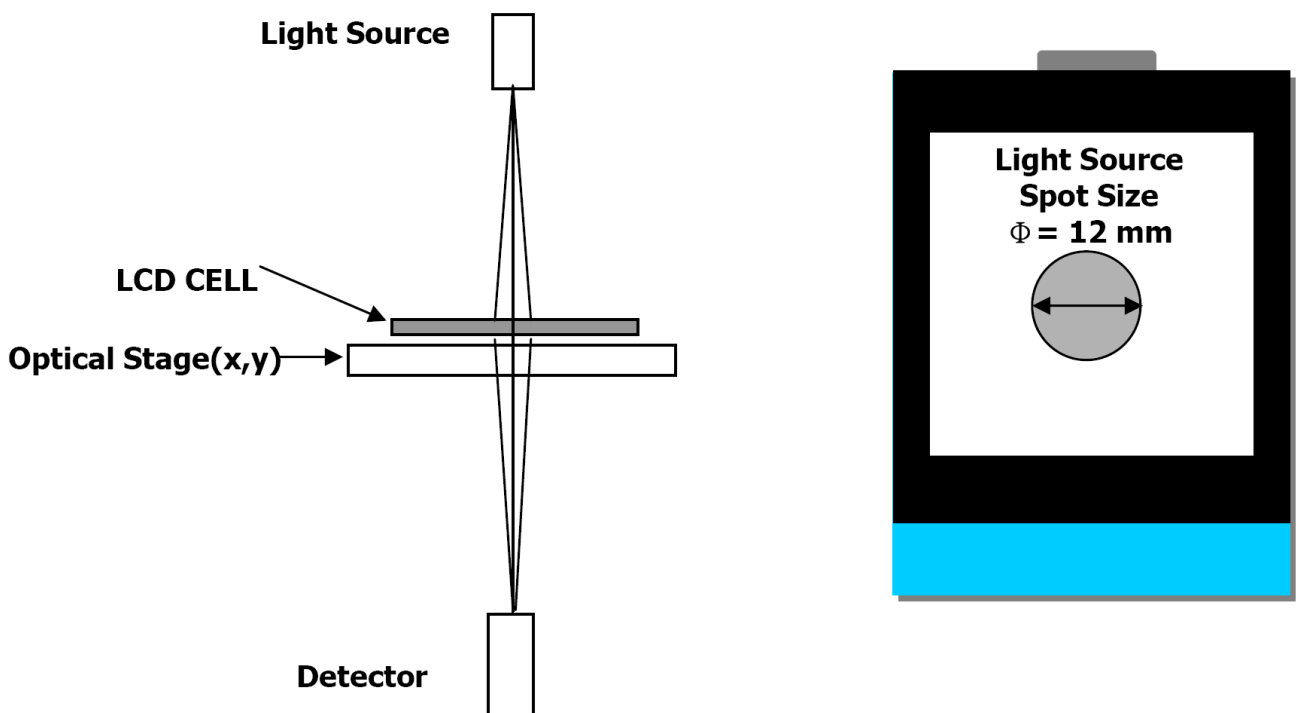
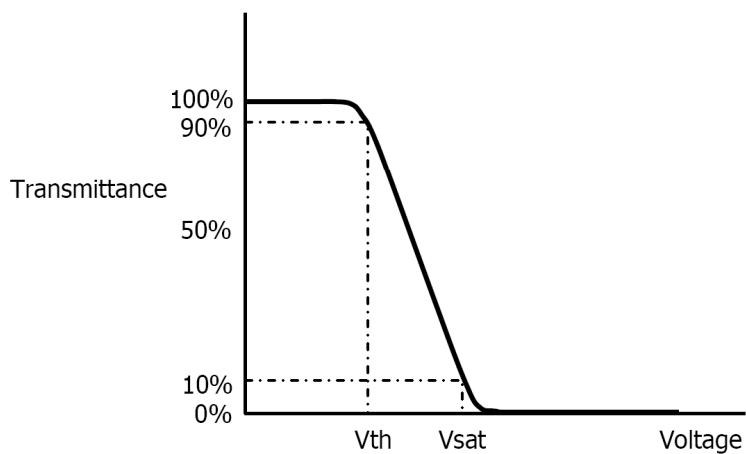

FIG. 2 The definition of  $V_{th}$  and  $V_{sat}$





**FIG. 3 The definition of Response Time**

The response time is defined as the following figure and shall be measured by switching the input signal for "black" and "white".

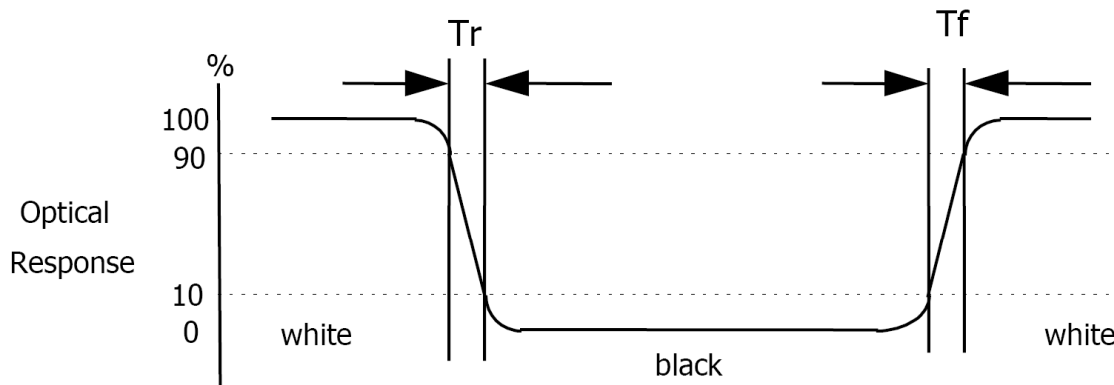

\* Voltage conditions for Response time  
 Vgate : 19V DC  
 Vdata : 0V~3.3V DC  
 Vcom : 0V (Ground)

**FIG. 4 The definition of viewing angle**  
 <dimension of viewing angle range>

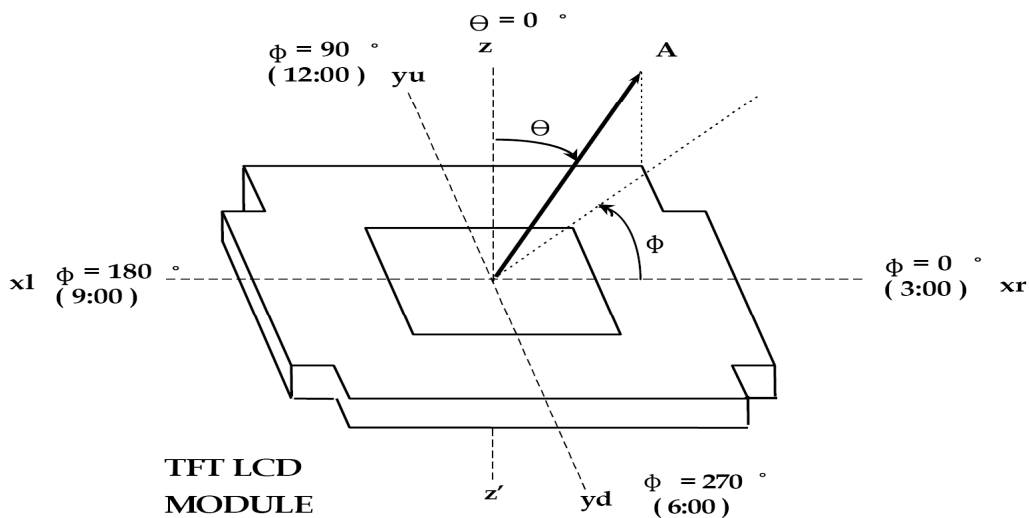

**9. APPLICATION CIRCUIT**

Please consult our technical department for detail information



## 10. INITIAL CODE

Pls consult our technical department for detail information

## 11. RELIABILITY TEST

### 11.1 Environment test

Test Item	Test Condition	Inspection after test
High Temperature Storage	70 °C 48hr	Inspection after 2~4hr storage at room temperature, the samples shall be free from defects: 1. Air bubble in the LCD 2. Sealleak. 3. Non-display 4. Glass crack 5. Missing segments; 6. Current Idd is twice higher than initial value. 7. Structure distortion
Low Temperature Storage	-20°C 48hr	
High Temperature Operating	60°C 48 hr	
Low Temperature Operating	-10°C 48hr	
Temperature Cycle	-20°C → 25°C → 80°C → 25°C (30min) (5min) (30min) (5min) 20 cycles	
Damp Proof Test	50°C 90%RH / 120hr	
Vibration Test	Frequency: 10Hz ~ 55Hz ~ 10Hz Amplitude: 1.5mm Z direction for total 3hr (Packing condition)	
Dropping Test	Drop to the ground from 1m height, one time , every side of carton (Packing condition)	
ESD Test	Voltage: ±6Kv / R:330 ohm /C:150pf /Air discharge,10time	

#### Remark:

1. The test samples is ok before test and should be applied to only one test item.
2. Sample qty for each test item is 3~5pcs.
3. For Damp Proof Test, pure water(resistance>10Mohm)should be used.
4. In case of malfunction defect caused by ESD damage, if it would be recovered to normal state after resetting, it would be judged as a good part. Using ionizer(an antistatic blower) is recommended at working area in order to reduce electro-static voltage. When removing protection film from LCM panel, peel off the tag slowly(recommended more than one second)while blowing with ionizer toward the peeling face to minimize ESD which may damage electrical circuit.
5. EL evaluation should be excepted from reliability test with humidity and temperature: Some defects such as black spot/blemish can happen by natural chemical reaction with humidity and fluorescence EL has.
6. Please use automatic switch menu or roll menu test mode when test operating mode.



## 11.2 Touch panel test

Test tool: pen tip R0.8mm & R8mm

Test Item	Test Condition	Judge standard
Hitting durability	300,000 times min at the same point Load: 150gf Hitting speed: 2times/sec Electric load: None	1) No glass break or glass crack after test 2) Resistance: X-axis: 200-900 ohm Y-axis: 200-900 ohm Insulation: >20M ohm
Pen sliding durability	50,000 times min Load:150gf Sliding speed 2 times/sec Electric load: None	
Globule striking	Globule fall off once from 30cm height Globule is a steel globe and its diameter is 9mm Electric load: None	

## 11.3 Ultraviolet radiation irradiation test

After ultraviolet irradiation, samples have no deterioration of display quality.

## 12. Quality Guaranty

### 12.1 Manufacture assurance

Item		100% test	Sampling	Reliability test
Raw material			○	○
LCM finished goods	Electrical function	○	○	○
	Appearance	○	○	○
	Physical characteristics		○	○
	Environmental condition		○	○

### 12.2 Inspection environment condition

12.2.1 Temperature and humidity : Room temperature(23±5℃)/ less than 70%RH.

12.2.2 Vision inspection distance : 30cm at the upright direction

12.2.3 Inspection method :

12.2.3.1 The appearance inspection should be performed under a daylight lamp (Power of 40W/ Distance of 1.5m will be a standard at any disputation)

12.3.2.2 During the electrical functional test and the screen defect inspection , the LCD should light electrically and the environment light should be avoided with a lens hood or the test is performed under a dark condition

12.3 Sample plan : GB/T2828-03(Ⅱ) AQL=1.0



## 12.4 Dimension measurement

11.4.1 Sample size : 5pcs per shipment lot

11.4.2 Criterion : Verify the important dimensions according to the appropriate drawing if needed and

should reject the dimensions that are out of the tolerance.

## 12.5 Appearance inspection

12.5.1 General Parts:

Item	Criterion	Remark
1.FPCA	The criterion for chip component solder point: IPC-A-610C CLASS 2 on general occasion .	Vision Inspection / Microscope
2.Back light	2.1 Defect of no light is unaccepted . 2.2 The brightness (test with BM-7 equipment) and power consume must meet SPEC	
3.Bezel	Any damage, distortion and other solder spark on the bezel surface is unaccepted .	
4.FPC	<p>4.1 Criterion for bending and crease As picture 22, "a" is the angle composed of the extended lines of the crease .This angle must be more than 90 degree.</p> <p>4.2 The area of crack, damage, foreign material and air bubble is not allowed to be more than 1/5 of that of the enhancing film ,</p> <p>4.3 Golden finger should not be scraped obviously; Any stain and foreign on the finger is unaccepted.</p>	Vision inspection / Microscope

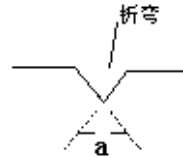

Picture 22





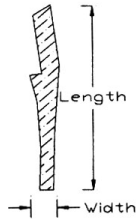
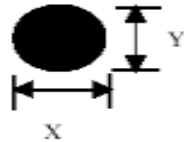

5.LCD screen	<p>5.1 A protect plaster should be stuck to the screen based on the SPEC.</p> <p>5.2 Any dust, finger mark, stain or other foreign material on the screen surface which can not be got rid of with soft cloth or air gun is unaccepted.</p> <p>5.3 Defect of no display is unaccepted.</p> <p>5.4 Defect of lack of line or cross-talk is unaccepted.</p> <p>5.5 Abnormal chroma, brightness and contrast (compared with golden Sample and SPEC parameter) are unaccepted</p> <p>5.6 Uneven back light (compared with golden Sample) or dark area is unaccepted.</p> <p>5.7 Response time of menu change must meet SPEC.</p> <p>5.8The LCD screen shift amount should not be more than 0.2mm based on the SPEC.</p> <p>5.9The criterion should be loosened in judging of the defect in the area out of V.A.</p>	Vision inspection
--------------	---	-------------------

12.5.2 Cosmetic defects of LCM(Include Touch Panel and TFT) out of acceptable criteria are listed in below table

Inspection item	Criterion	Remark															
Liner matter	<table border="1" style="width: 100%;"> <thead> <tr> <th style="width: 33%;">Width (mm)</th> <th style="width: 33%;">Length (mm)</th> <th style="width: 34%;">Q'ty</th> </tr> </thead> <tbody> <tr> <td style="text-align: center;"><math>W \leq 0.1</math></td> <td style="text-align: center;">/</td> <td style="text-align: center;">Ignore</td> </tr> <tr> <td style="text-align: center;"><math>0.1 &lt; W \leq 0.2</math></td> <td style="text-align: center;"><math>L \leq 5</math></td> <td style="text-align: center;">3</td> </tr> <tr> <td style="text-align: center;"><math>W &gt; 0.2</math></td> <td style="text-align: center;">/</td> <td style="text-align: center;">0</td> </tr> </tbody> </table>	Width (mm)	Length (mm)	Q'ty	$W \leq 0.1$	/	Ignore	$0.1 < W \leq 0.2$	$L \leq 5$	3	$W > 0.2$	/	0				
Width (mm)	Length (mm)	Q'ty															
$W \leq 0.1$	/	Ignore															
$0.1 < W \leq 0.2$	$L \leq 5$	3															
$W > 0.2$	/	0															
Scratch	<table border="1" style="width: 100%;"> <thead> <tr> <th style="width: 33%;">Width (mm)</th> <th style="width: 33%;">Length (mm)</th> <th style="width: 34%;">Q'ty</th> </tr> </thead> <tbody> <tr> <td style="text-align: center;"><math>W \leq 0.03</math></td> <td style="text-align: center;">/</td> <td style="text-align: center;">Ignore</td> </tr> <tr> <td style="text-align: center;"><math>0.03 &lt; W \leq 0.05</math></td> <td style="text-align: center;"><math>L \leq 5</math></td> <td style="text-align: center;">2</td> </tr> <tr> <td style="text-align: center;"><math>0.05 &lt; W \leq 0.1</math></td> <td style="text-align: center;"><math>L \leq 2</math></td> <td style="text-align: center;">2</td> </tr> <tr> <td colspan="2" style="text-align: center;"><math>W &gt; 0.1 \text{ mm or } L &gt; 2 \text{ mm}</math></td> <td style="text-align: center;">0</td> </tr> </tbody> </table>	Width (mm)	Length (mm)	Q'ty	$W \leq 0.03$	/	Ignore	$0.03 < W \leq 0.05$	$L \leq 5$	2	$0.05 < W \leq 0.1$	$L \leq 2$	2	$W > 0.1 \text{ mm or } L > 2 \text{ mm}$		0	As liner
Width (mm)	Length (mm)	Q'ty															
$W \leq 0.03$	/	Ignore															
$0.03 < W \leq 0.05$	$L \leq 5$	2															
$0.05 < W \leq 0.1$	$L \leq 2$	2															
$W > 0.1 \text{ mm or } L > 2 \text{ mm}$		0															
Fish eye on film/ Dent on film and Air bubble	<table border="1" style="width: 100%;"> <thead> <tr> <th style="width: 50%;">Size (mm)</th> <th style="width: 50%;">Q'ty</th> </tr> </thead> <tbody> <tr> <td style="text-align: center;"><math>D \leq 0.5</math></td> <td style="text-align: center;">Ignore</td> </tr> <tr> <td style="text-align: center;"><math>0.5 &lt; D &lt; 1.0</math></td> <td style="text-align: center;">2</td> </tr> <tr> <td style="text-align: center;"><math>D &gt; 1.0</math></td> <td style="text-align: center;">0</td> </tr> </tbody> </table>	Size (mm)	Q'ty	$D \leq 0.5$	Ignore	$0.5 < D < 1.0$	2	$D > 1.0$	0	<p>Size : <math>D = (X+Y)/2</math></p> 							
Size (mm)	Q'ty																
$D \leq 0.5$	Ignore																
$0.5 < D < 1.0$	2																
$D > 1.0$	0																

Dot	Size (mm)	Q'ty	As fish eye
	$D \leq 0.15$	Ignore	
	$0.15 < D \leq 0.25$	2	
	$0.25 < D \leq 0.35$	1	
	$D > 0.35$	0	
Newton's ring	<p>Rules  1. 周期性</p> <p>irregular  2. 非周期性</p> <p><math>\leq 1/3</math> TP area</p> <p>Function OK</p>	As fish eye	

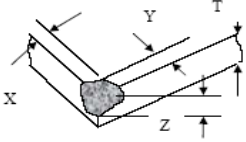
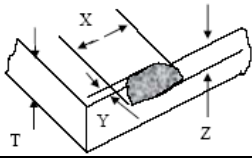
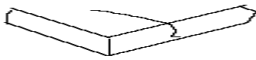
Chip and crack	<p>Corner chip</p> 	$X \leq 3\text{mm}$ $Y \leq 3\text{mm}$ $Z \leq T$
	<p>General chip</p> 	$X \leq 3\text{mm}$ $Y \leq 3\text{mm}$ $Z \leq T$ Or $X \leq 5\text{mm}$ $Y \leq 1\text{mm}$ $Z \leq T$
	<p>Crack</p> 	0

### 12.5.3 TFT Pixel Inspection

1) Pixel

b-pixels ( R+G+B )



2) DOT

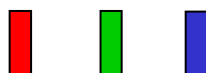

1 sub-pixel (R or G or B / or or )

### 3) Bright/Dark Dot

A sub-pixel (R,G, B dot) stuck off/on (electrical)

Bright dots shall be counted on a black pattern and black dots on a pure R,G, B and white pattern.

### 4) Adjacent Dot

2 or 3 dots connected with neighboring dot. (R,G or G,B or B,R or R,G,B )

## 12.5.4 TFT Pixel Dot Defect Criteria

Defect Mode	Acceptable Judgment Criteria	
	Dot Type	Quantity (ea)
Bright Dot	Random (Red, Blue, Green)	1
	2 or more adjacent dot defects	0
Dark Dot	Dark dot	3
	2 adjacent dots	1
	3 or more adjacent dots	0

## 12.6 Function test

12.6.1 To set the voltage and current based on the specification requirement of the product make the LCD electrically light, then test LCD, the product will be accepted if its LCD can display normally.

12.6.2 The product should be judged as fail if there is any test item fails in passing the test.

12.6.3 If the product fails in test, it should be tested serially two times again, if it pass the testing in the last two times, then it should be accepted.

**12.7 Accepted criterion :** For a out going lot, We inspect it based on above sampling plan and the corresponding acceptable criterion, if all inspection items meet the SPEC , this lot should be accepted and rejected otherwise.

## 12.9 Package and storage

### 12.9.1 Placement

To handle lightly; to store in clear environment; to avoid direct daylight.

### 12.9.2 Cleaning method

Only soft cloth or equal material can be used to clean the screen gently. It is prohibited to use any stiff or other unproposed liquid to clean the screen. Especially below material is absolutely prohibited:

- Water
- Ketone
- Aromaticity compound

### 12.9.3 Package and storage method

- 1) Please place the product according to the method showed on the packing box.
- 2) All products should be handled and placed lightly avoiding any bump and knock, especially throw onto the earth.
- 3) Once the pack is opened, extreme temperature & humidity and dust should be avoided.
- 4) There must be Anti-ESD measure to protect the product during usage (the product include CMOS component)
- 5) All returned defective products should be rightly packaged with their original packing material and method.
- 6) To prevent modules from degradation, Do not operate or store them exposed direct to sunshine or high temperature/humidity

### 12.9.4 In case of storing for long period of time, the following ways are recommended:

- 1) Storage in polyethylene bag with opening sealed so fresh air outside can not enter in, and with no desiccant.
- 2) Placing in a dark place where neither exposure to direct sunlight nor light is keeping the storage temperature range.
- 3) Storing with no load on package surface by anything else.

## 13.0 General Precautions for touch panel

In order to prevent accidental use and performance deterioration, please keep the following precautions and inhibited points.

- 13.1. Transparency is an important factor for the product. So, please wear clean finger sacks, handling gloves and mask to protect the products from fingerprint or stain attach, and also hold the portion outside the view area when handling the panel.
- 13.2. Do not put a heavy, hard or sharp object on the product.
- 13.3. Wipe off the stain on the product by using soft cloth moistened with ethanol. Take care not to allow ethanol to soak into the joint of upper Film and bottom glass. Do not use any organic solvent or detergent other than ethanol.
- 13.4. Do not clean with a thing other than the finger such as hard or sharp edges like a finger nail etc. on the cloth, because it cause transparent conductive film cracks. Please advise this inhibition to your last customers

13.5. Operate it with a polyacetal pen (tip R0.8 or over) or a belly of a finger without applying operation excessive load. Do not operate by other than polyacetal pen (tip R0.8 or over) and/or a belly of a finger like a hard or a sharp edges such as a ball point pen, sharp pencil, sharp tiptoe, etc. Operation at the out of Active Area is out of our guarantee. Because, it causes a serious damage of a transparent electrode. Do not operate at the out of Active Area.

13.6. Design guide -----important message, please read it carefully.

**(1) Electrical aspect**

1. Keep the voltage under DC 7V operating the T/P.
2. The Touch Panel cannot work correctly while touch two separate points at the same time.
3. The contact resistance need to be stabilized before read the position figure.
4. Please design the capacitor value of the touch panel in your sensing circuit and low-pass filters as it acts in an equivalent circuit.

**(2) Software**

It should be have the location calibration function in customer's software.

Please include "User calibration" in your software programming for long term using.

**(3) Mechanical Design**

**Active Area**

The linearity, durability, and the operating force is guaranteed inside this area.

1. Please design your function area inside the "Active Area", which is 1mm~1.5mm inside of the transparent insulation area.
2. Usually, the "Active Area" is equal or more than customer's display "Active Area".
3. Due to the construction and the material character, the durability of the input area at the edge is less than the center area; suggest not placing the key function at the edge area.

**Unbearable Area**

1. It still can be activated at this area, only the resistance is not stately, the linearity could not be guaranteed.
2. While in design, to prevent the potential problem is to avoid the housing of the unit to have any contact from the touch panel, or possible pressing on it while holding it. The contact causes the malfunction.
3. Normally, the durability is not guaranteed. The sliding in this area may cause the damage of the touch panel.

- Usually the width of unbearable area is 1~1.5mm from “Active Area”, please check our specific drawing for each size, or discuss with our engineer.

### Transparent Insulation-area

- The Insulation area is located outside the “Active Area” with a distance of 1~1.5mm. Please see the attached drawing of cross-section construction. It is to prevent the malfunction of the housing edge contacting the touch panel.
- We suggest your housing design at least keep. 1.0mm outside the inner edge of Transparent Area. Please see the attached drawing of cross-section construction.

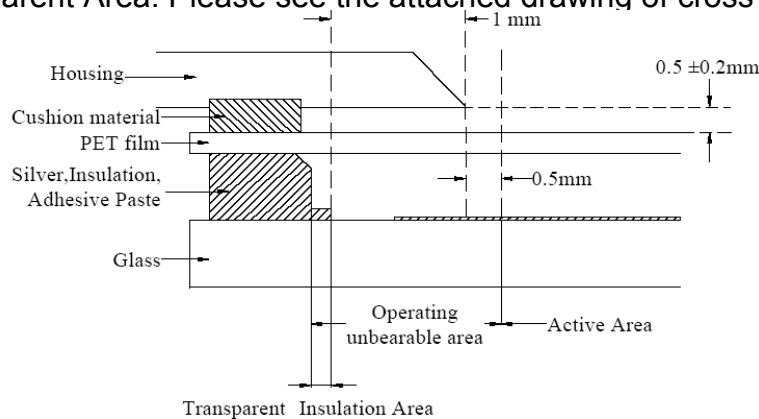

## 14.0 Other agree

### 14.1 Criterion ap

#### 14.1.1 Criterion confirmation

Before lot delivery, the inspection criterion and method proposed by WaveTop must be confirmed by customer and WaveTop respectively. The confirmed criterion and method will be taken as quality criterion for WaveTop outgoing inspection and customer incoming inspection.

- If there is unclear item in this criterion , the agreement can be achieved by making a reference sample after being discussed by two parties.

- Any defect which is not defined or mentioned in this criterion must be confirmed and discussed by the two parties to determine whether it is acceptable.

#### 14.2 Production guaranty period

The Lot production guaranty period is 12 months from the date when customer receives the product (the product should be used under the condition recommended by WaveTop). WaveTop should respond for the expense caused by repairing or changing the defective product , and WaveTop should assist the customer to resolve the problem fed back by customer. The inspection method that will be performed by customer and WaveTop. The confirmed criterion and method will be the quality criterion in WaveTop out going inspection and customer incoming inspection.

### 14.3 Disposal of defective product

Within the guaranty period, WaveTop product defect found in the incoming inspection process, Test and finished goods inspection should be dealt with based on below principles.

#### 14.3.1 Analysis and improvement for defective product.

- 1) On occasion when serious defect occurs or there is special requirement from customer, WaveTop should analyze the defect root cause and take corresponding corrective actions.
- 2) Customer should provide WaveTop with the defective sample or its picture and the production lot number and other necessary information for analysis.
- 3) The analysis report and the corrective action report should be provided by WaveTop in 10 days after the analysis result is worked out.

#### 14.3.2 Disposal on site

If it is necessary for WaveTop analyst to do on-site defect analyze, WaveTop analyst or related people should arrive at the appointed factory in time according to the customer requirement (limited in china main land). The customer should open the production line and provide necessary area and equipment or other condition for WaveTop to analyze.

#### 14.3.3 Disposal of returned defective product

Under the condition of that customer line can keep producing, customer return the defective products back to WaveTop exactly the amount then WaveTop should repair the defective product rapidly and delivery them back to customer. Customer should supply statistic information of defect happening in process and field periodically or by quantity and to WaveTop. After receiving the report, WaveTop should come to the spot to confirm the defect with customer and exchange the defective products, which caused by themselves with equal quantity good products. For those defective products caused by customer incorrect usage, WaveTop has the duty to help customer repair them, and the repairing expense should be determined based on the discussion between customer and.

14.4 The criterion should be advisably loosen (waive) if the defect do not influence the mobile function and appearance, if necessarily, the problem should be resolved through by discussing between customer and WaveTop.

#### 14.5 Recommended usage condition

Operation temperature : 15°C~30°C.

Operation humidity : 45~85%RH

The product should be stored under the recommended condition to keep its normal Characteristics.

14.6 In order to protect the LCD, glove should be used to avoid the stain and finger mark during the assembling or any operation in which the operator may directly touch the LCD.

14.7 A good communication should be established between customer and Wavetop, in order to resolve the problem, special personnel should be appointed for convenient communication.

END