



SPECIFICATION FOR TFT LCD MODULE

MODEL NO: LC DT177102-2001

Customer Approval:

- Approve Specification Only
- Approve Specification and Sample

APPROVED BY
DATE:

ISSUED DATE: 2010/1/10

PREPARED BY	CHECKED BY	APPROVED BY



Contents

1	Introduction-----	4
2	General specification-----	5
3	Mechanical drawing-----	6
4	Absolute maximum ratings-----	7
5	Electrical characteristics-----	7
6	Optical characteristics -----	8
7	Pin Assignment -----	11
8	Block diagram -----	13
9	Caution -----	13
10	LCM quality criteria-----	14



1. Introduction

1.1 Scope of application

This specification applies to the Negative type TFT transmissive dot matrix LCD module that is supplied by SHENZHEN RISHI TLECTRON CO. LTD. This LCD module should be designed for mobile phone use.

LCD specification: Duty 1/160, Dots 128xRGBx160

As to basic specification of the driver IC, refer to the IC (ILI9163C) specification and data book.

All material & processing of the LCD module should be Lead Free.

Structure:

Single display structure:

TFT PANEL+BL+FRAME ;

FULL 65k/262K Color 1.77 inch TFT LCD;

One bare chip with gold bump (COG) TECH;

8bit 8080 MPU input interface;

1.3 TFT features:

Structure: TFT PANNEL+IC+FPC;

Transmissive Type LCD

128 dot-segment and 160 dot-common outputs;

65k or 262k Color can be selected by software;

White LED back light;

1.4 Applications:

Mobile phone

PDA

GAME PLAYER

GPS

ETC...



2. General specification

ITEM	Standard value	UNIT
LCD SIZE	1.77	INCH
LCD Type	TFT Negative Transmissive	---
Driver Element	a-Si TFT Active matrix	---
Number of Dots	128*(RGB)*160	Dots
Pixel Arrangement	RGB Vertical Stripe	---
Pixel Pitch (W*H)	/	mm
Active Area	28.03*35.04	mm
Viewing Area (W*H)	/	mm
Glass Area (W*H)	/	mm
LCD Duty	1/160	---
Viewing Direction	12 O' clock	---
Control IC	lli9163c	---
Module Size(W*H*T)	34.0(W)*46.00(L)*3(H)	mm
Approx. Weight	TBD	g
Back Light	White LED	



2. Mechanical drawing

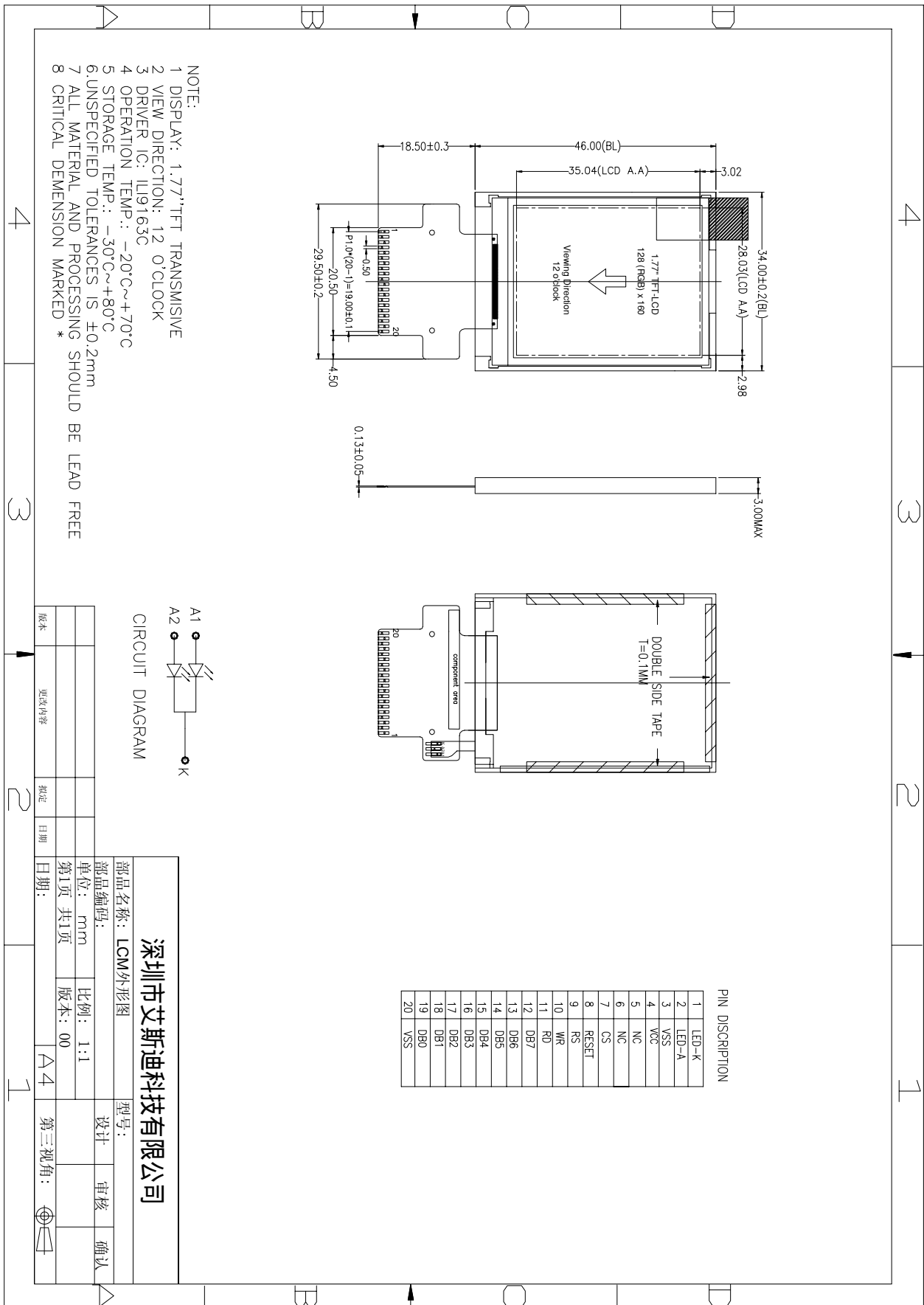



4. Absolute Maximum Ratings

Parameter	Symbol	Min	Max	Unit
Supply voltage for logic	VDDEXT	-0.3	3.6	V
Supply voltage for I/O INTERFACE	VDDIO	-0.3	3.6	V
Input voltage for logic	VCI	-0.3	3.6	V
Supply current(LED)	ILED	--	70	mA
Operating temperature	Top	-10	+60	°C
Storage temperature	Tst	-20	+70	°C

5. Electrical Characteristics

Item	Symbol	Min	Typ	Max	Unit	Applicable terminal
Supply voltage for logic	VDDEXT	2.5	-	3.6	V	-
Power Supply For IO	VDDIO	1.4	-	3.6	V	-
Input voltage for logic	VCI	2.5		3.6	v	VCI
Supply backlight voltage	V _{LED}	3.0	3.2	3.4	V	--
Input backlight current	I _{LED}	-	30	-	mA	-



6. Optical Characteristics

ITEM		SYMBOL	CONDITIONS	SPECIFICATIONS			UNIT	NOTE
				MIN.	TYP.	MAX		
Luminance		L	Viewing normal angle	150	180	--	cd/m ²	All left side data are based on RISHI' s product reference only
Contrast Ratio		CR		--	300	--	--	
Response Time		Tr+Tf		--	25	--	Ms	
CIE Color coordinate	Red	X _R		0.631	0.651	0.671		
		Y _R		0.311	0.331	0.351		
	Green	X _G		0.281	0.301	0.321		
		Y _G		0.565	0.585	0.605		
	Blue	X _B		0.113	0.133	0.153		
		Y _B		0.116	0.136	1.156		
White	X _w	0.289		0.309	0.329			
	Y _w	0.324	0.344	0.364				
Viewing Angle	Hor.	θ_{x+}	Center CR>=5	--	60	--	Deg.	
		θ_{x-}		--	60	--		
	Ver.	θ_{y+}		--	70	--		
		θ_{y-}			65			
Uniformity	Un			80	85		%	
NTSC RATIO					61.5		%	

Note 1 : Definition of Viewing Angle θ_x and θ_y :

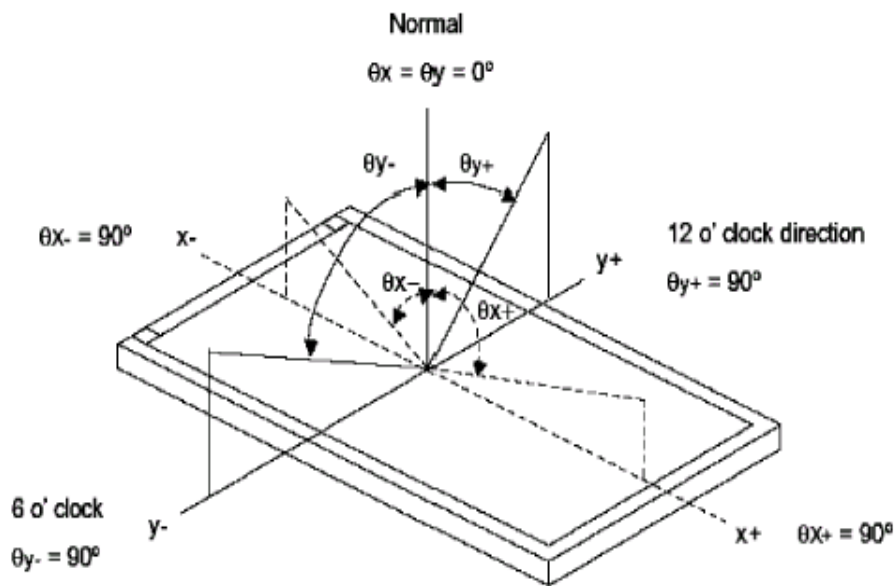

Note 2: Definition of contrast ratio CR:

$$CR = \frac{\text{Brightness of non-selected dots (white)}}{\text{Brightness of selected dots (black)}}$$

Note 3: Definition of response time (T_R , T_F)

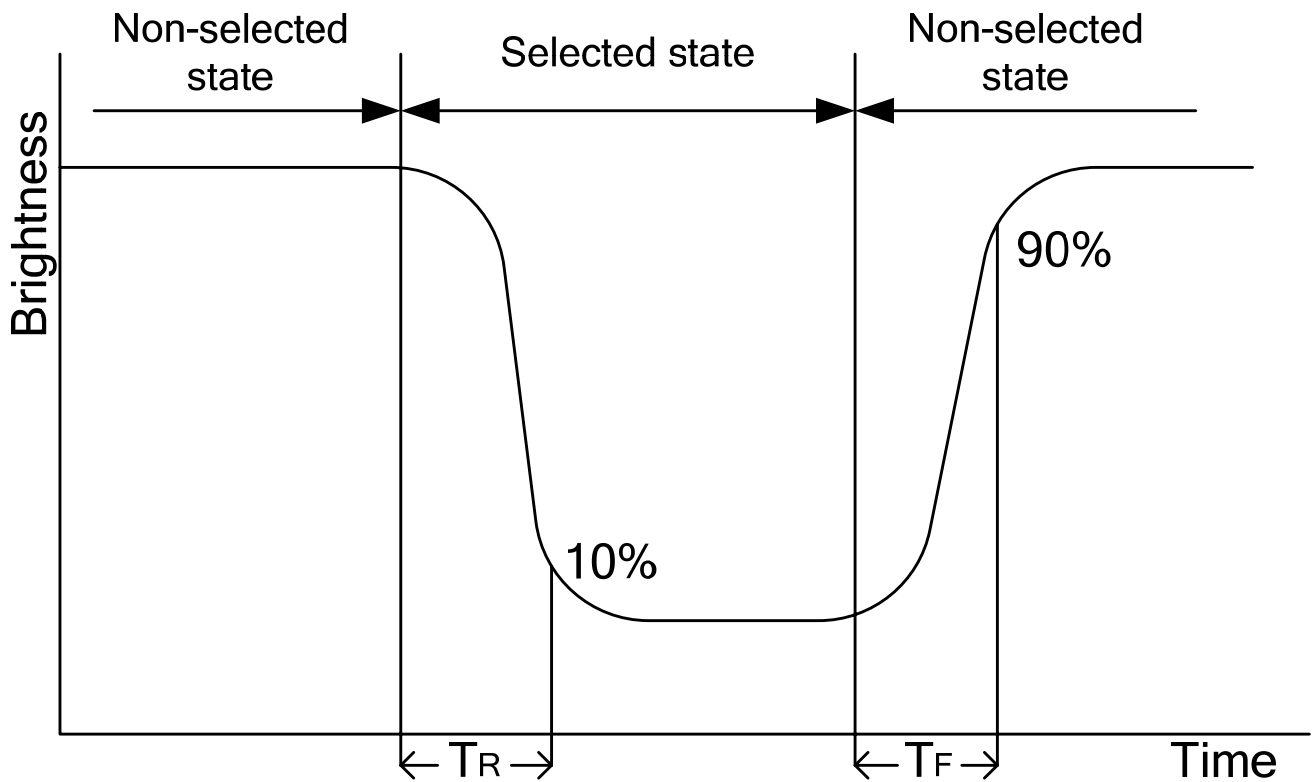



The brightness test equipment setup

20mA Field=2° (As measuring "black" image, field=2° is the best testing condition)

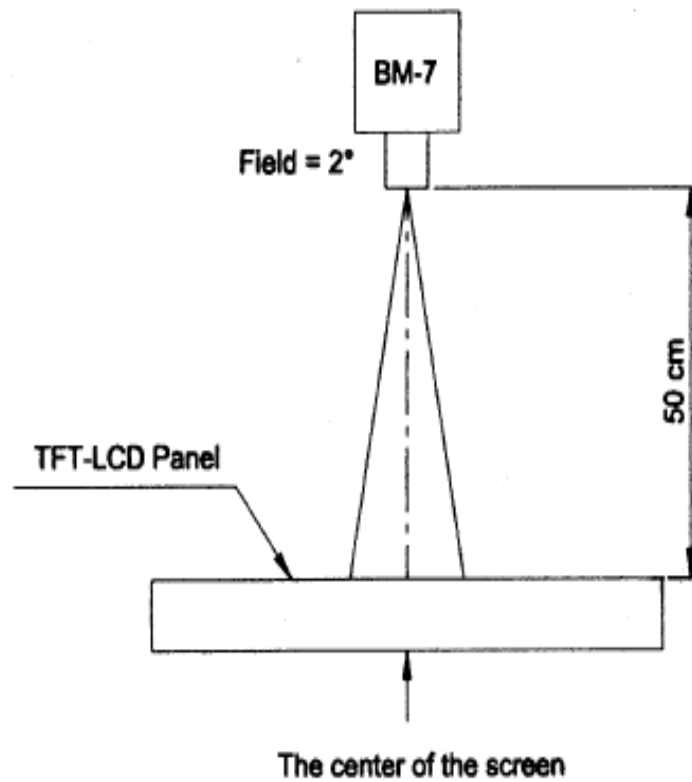

Note 4 :

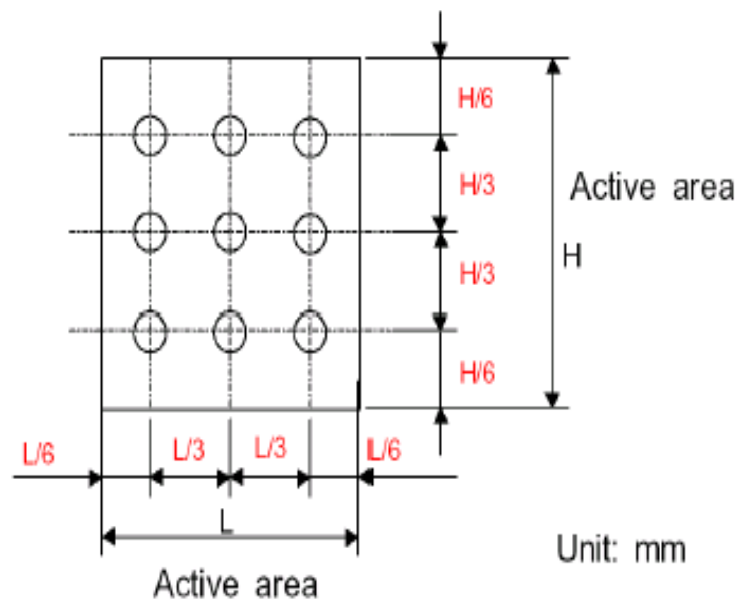



7. MCU Interface Pin Function

NO.	SYMBOL	Description	I/O
1	LEDK	LED Cathode	Power Supply
2	LEDA	LED Anode (3.2V)	Power Supply
3	GND	Ground	Power Supply
4	VCC	Power Supply for Logic(3.3V)	Power Supply
5	NC	No connected	I
6	NC	No connected	I
7	CS	Chip selection	I
8	RESET	Reset	I
9	RS	Command/Data select "H" : Data;" L" :Command	I
10	RW	Write signal	I
11	RD	Read signal	I
12	DB7	8 bit 8080 MCU data port.	I
13	DB6		I
14	DB5		I
15	DB4		I
16	DB3		I
17	DB2		I
18	DB1		I
19	DB0		I
20	GND	Ground	Power Supply



8. Block Diagram

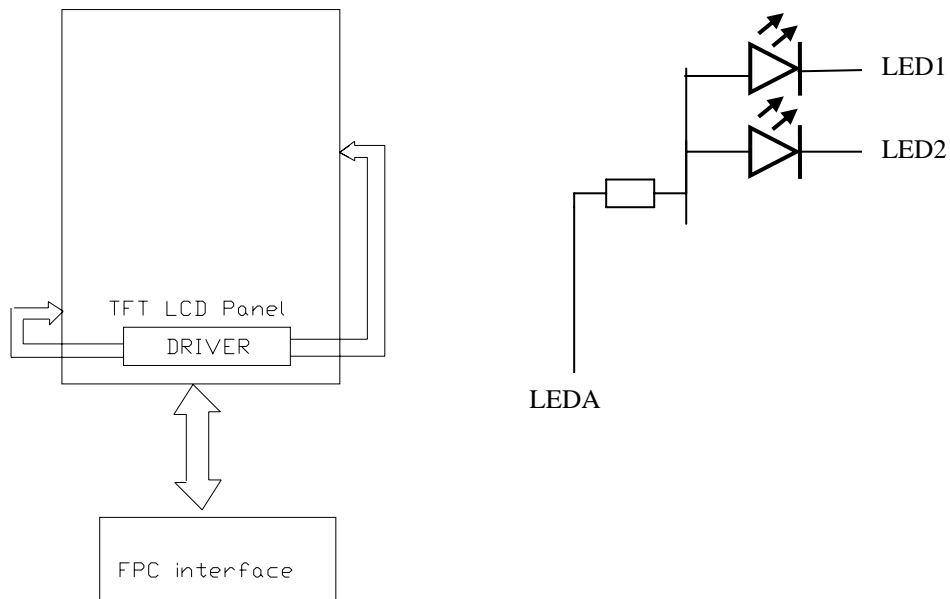

9. Caution

9.1 Handling of LCM

- . Be sure to ground the body when handling the LCM.
- . Don't give external shock
- . Don't apply excessive force on the surface.
- . Liquid in LCD is hazardous substance. Must not lick and swallow.
When the liquid is attach to your hand, skin, cloth etc. Wash it out thoroughly and immediately.
- . Don't operate it above the absolute maximum rating.
- . Don't disassemble the LCM

9.2 Storage

- . Store in an ambient temperature of 5°C to 45°C, and in a relative humidity of 40% to 60%. Don't expose to sunlight or intensive ultraviolet rays
- . Storage in a clean environment, free from dust, active gas, and solvent.
- . Store in anti-static electricity container.
- . Store without any physical load.

9.3 Safety instructions:

- 10.3.1 If the LCD panel breaks, be careful not to get the liquid crystal to touch you skin.
- 10.3.2 If the liquid crystal touches your skin or clothes, please wash it off immediately by using soap and water.

9.4 Handling

- 10.4.1 Avoid static electricity which can damage the LSI.
- 10.4.2 Do not remove the panel or frame from the module.
- 10.4.3 The polarizing plate of the display is very fragile. So, please handle it very carefully.
- 10.4.4 Do not wipe the polarizing plate with a dry cloth, as it may easily scratch the surface the plate.
- 10.4.5 Do not use ketonic solvent & aromatic solvent. Use a soft cloth soaked with a cleaning naphtha solvent.
- 10.4.6 The color tone of display and background on LCD has the possibility to be changed in the storage temperature range.
- 10.4.7 Pay attention to the working environment, as the element may be destroyed by static electricity.
 - Be sure to ground human body and electric appliance during work.
 - Avoid working in a dry environment to minimize the generations of static electricity.
 - Static electricity may be generated when the protective film is fast peeled off.

9.5 Operation instructions:

It is recommended to drive the LCD within the specified voltage limits, try to adjust the operating voltage for the optimal contrast, the color and contrast of LCD panel will varies at different temperature, adjust the operating voltage for the optimal contrast.

The response time of the LC fluid is considerably longer response at low temperatures than that in the normal operating temperature range.

Do not operate the LCD at the environments over the specified conditions, this may cause damage on the LCD and shorten the lifetime.

9.6 Storage instructions:

10.6.1 Keep the LCD panel at a temperature of 15°C~35°C and at a relative humidity of 65% or less for long-term storage.

10.6.2 Keep the LCD panel away from high temperature (>40°C) and high humidity (>80%) environment for long-term storage.

10.6.3 Store away from direct sunlight and fluorescent light for long term storage, store the LCD panel in a dark place or cover it with black clothes, avoid to cover something or make marks on part of the LCD panel when exposing to light for long time.

10.6.4 Do not store the LCD panels in the environments over the specified storage conditions.



10. RISHI LCM Quality Criteria

This specification is made to be used as the standard acceptance/rejection criteria for mobile phone LCM.

1.0 VISUAL & FUNCTION INSPECTION STANDARD

1.1 Inspection conditions

Inspection performed under the following conditions is recommended.

Temperature : $25 \pm 5^\circ\text{C}$

Humidity : $65\% \pm 10\% \text{RH}$

Viewing Angle : Normal viewing Angle.

Illumination: Single fluorescent lamp (300 to 700Lux)

Viewing distance:30-50cm

1.2 Definition

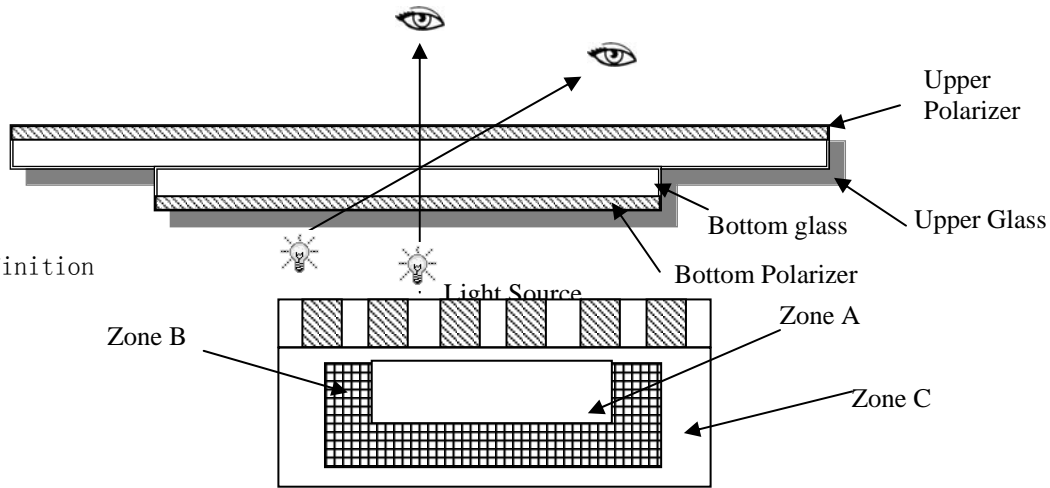

Zone A : Effective Viewing Area(Character or Digit can be seen)

Zone B : Viewing Area except Zone A

Zone C : Outside (Zone A+Zone B) which can not be seen after assembly by customer .)

Note:

As a general rule ,visual defects in Zone C can be ignored when it doesn't effect product function or appearance after assembly by customer.

1.3 Sampling Plan

According to GB/T 2828-2003 ; , normal inspection, Class II

AQL:

Major defect	Minor defect
0.65	1.5

LCD: Liquid Crystal Display , TP: Touch Panel , LCM: Liquid Crystal Module

No	Items to be inspected	Criteria	Classification of defects
1	Functional defects	1) No display, Open or miss line 2) Display abnormally, Short 3) Backlight no lighting, abnormal lighting. 4) TP no function	Major
2	Missing	Missing component	
3	Outline dimension	Overall outline dimension beyond the drawing is not allowed	
4	Color tone	Color unevenness, refer to limited sample	Minor
5	Soldering appearance	Good soldering , Peeling off is not allowed.	
6	LCD/Polarizer/TP	Black/White spot/line, scratch, crack, etc.	

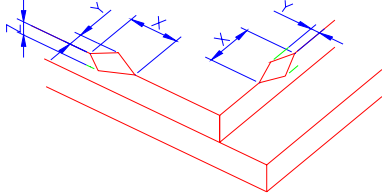
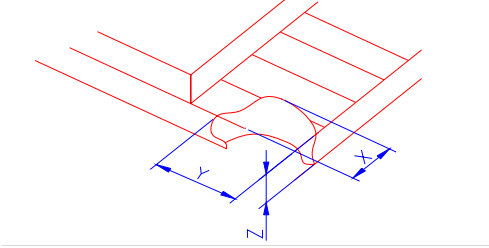
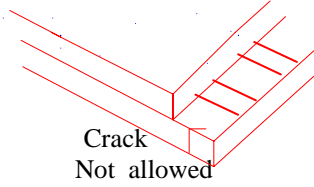

1.4 Criteria (Visual)

Number	Items	Criteria(mm)						
1.0 LCD Crack/Broken NOTE: X: Length Y: Width Z: Height L: Length of ITO, T: Height of LCD	(1) The edge of LCD broken	 <table border="1" data-bbox="804 748 1348 904"> <thead> <tr> <th>X</th> <th>Y</th> <th>Z</th> </tr> </thead> <tbody> <tr> <td>≤3.0mm</td> <td><Inner border line of the seal</td> <td>≤T</td> </tr> </tbody> </table>	X	Y	Z	≤3.0mm	<Inner border line of the seal	≤T
X	Y	Z						
≤3.0mm	<Inner border line of the seal	≤T						
	(2)LCD corner broken	 <table border="1" data-bbox="863 1189 1286 1256"> <thead> <tr> <th>X</th> <th>Y</th> <th>Z</th> </tr> </thead> <tbody> <tr> <td>≤3.0mm</td> <td>≤L</td> <td>≤T</td> </tr> </tbody> </table>	X	Y	Z	≤3.0mm	≤L	≤T
X	Y	Z						
≤3.0mm	≤L	≤T						
	(3) LCD crack	 <p>Crack Not allowed</p>						



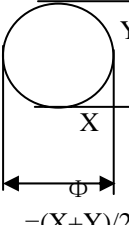

Number	Items	Criteria (mm)																							
2.0	Spot defect 	① light dot (LCD/TP/Polarizer black/white spot, light dot, pinhole, dent, stain)																							
		<table border="1"> <thead> <tr> <th rowspan="2">Zone Size (mm)</th> <th colspan="3">Acceptable Qty</th> </tr> <tr> <th>A</th> <th>B</th> <th>C</th> </tr> </thead> <tbody> <tr> <td>$\Phi \leq 0.10$</td> <td colspan="3">Ignore</td> </tr> <tr> <td>$0.10 < \Phi \leq 0.15$</td> <td colspan="3">3(distance $\geq 10\text{mm}$)</td> </tr> <tr> <td>$0.15 < \Phi \leq 0.2$</td> <td colspan="3">1</td> </tr> <tr> <td>$0.2 < \Phi$</td> <td colspan="3">0</td> </tr> </tbody> </table>	Zone Size (mm)	Acceptable Qty			A	B	C	$\Phi \leq 0.10$	Ignore			$0.10 < \Phi \leq 0.15$	3(distance $\geq 10\text{mm}$)			$0.15 < \Phi \leq 0.2$	1			$0.2 < \Phi$	0		
		Zone Size (mm)		Acceptable Qty																					
			A	B	C																				
		$\Phi \leq 0.10$	Ignore																						
		$0.10 < \Phi \leq 0.15$	3(distance $\geq 10\text{mm}$)																						
		$0.15 < \Phi \leq 0.2$	1																						
		$0.2 < \Phi$	0																						
		② Dim spot (LCD/TP/Polarizer dim dot, light leakage, dark spot)																							
		<table border="1"> <thead> <tr> <th rowspan="2">Zone Size (mm)</th> <th colspan="3">Acceptable Qty</th> </tr> <tr> <th>A</th> <th>B</th> <th>C</th> </tr> </thead> <tbody> <tr> <td>$\Phi \leq 0.1$</td> <td colspan="3">Ignore</td> </tr> <tr> <td>$0.1 < \Phi \leq 0.2$</td> <td colspan="3">2(distance $\geq 10\text{mm}$)</td> </tr> <tr> <td>$0.2 < \Phi \leq 0.3$</td> <td colspan="3">1</td> </tr> <tr> <td>$\Phi > 0.3$</td> <td colspan="3">0</td> </tr> </tbody> </table>	Zone Size (mm)	Acceptable Qty			A	B	C	$\Phi \leq 0.1$	Ignore			$0.1 < \Phi \leq 0.2$	2(distance $\geq 10\text{mm}$)			$0.2 < \Phi \leq 0.3$	1			$\Phi > 0.3$	0		
		Zone Size (mm)		Acceptable Qty																					
			A	B	C																				
		$\Phi \leq 0.1$	Ignore																						
		$0.1 < \Phi \leq 0.2$	2(distance $\geq 10\text{mm}$)																						
		$0.2 < \Phi \leq 0.3$	1																						
$\Phi > 0.3$	0																								
③ Polarizer accidented spot																									
<table border="1"> <thead> <tr> <th rowspan="2">Zone Size (mm)</th> <th colspan="3">Acceptable Qty</th> </tr> <tr> <th>A</th> <th>B</th> <th>C</th> </tr> </thead> <tbody> <tr> <td>$\Phi \leq 0.2$</td> <td colspan="3">Ignore</td> </tr> <tr> <td>$0.2 < \Phi \leq 0.5$</td> <td colspan="3">2(distance $\geq 10\text{mm}$)</td> </tr> <tr> <td>$\Phi > 0.5$</td> <td colspan="3">0</td> </tr> </tbody> </table>	Zone Size (mm)	Acceptable Qty			A	B	C	$\Phi \leq 0.2$	Ignore			$0.2 < \Phi \leq 0.5$	2(distance $\geq 10\text{mm}$)			$\Phi > 0.5$	0								
Zone Size (mm)		Acceptable Qty																							
	A	B	C																						
$\Phi \leq 0.2$	Ignore																								
$0.2 < \Phi \leq 0.5$	2(distance $\geq 10\text{mm}$)																								
$\Phi > 0.5$	0																								



	Line defect (LCD/TP /Polarizer black/white line, scratch, stain)	<table border="1"> <thead> <tr> <th rowspan="2">Width(mm)</th> <th rowspan="2">Length(mm)</th> <th colspan="3">Acceptable Qty</th> </tr> <tr> <th>A</th> <th>B</th> <th>C</th> </tr> </thead> <tbody> <tr> <td>$\Phi \leq 0.03$</td> <td>Ignore</td> <td colspan="2">Ignore</td> <td rowspan="3">Ignore</td> </tr> <tr> <td>$0.03 < W \leq 0.05$</td> <td>$L \leq 3.0$</td> <td colspan="2">$N \leq 2$</td> </tr> <tr> <td>$0.05 < W \leq 0.08$</td> <td>$L \leq 2.0$</td> <td colspan="2">$N \leq 2$</td> </tr> <tr> <td>$0.08 < W$</td> <td colspan="4">Define as spot defect</td> </tr> </tbody> </table>	Width(mm)	Length(mm)	Acceptable Qty			A	B	C	$\Phi \leq 0.03$	Ignore	Ignore		Ignore	$0.03 < W \leq 0.05$	$L \leq 3.0$	$N \leq 2$		$0.05 < W \leq 0.08$	$L \leq 2.0$	$N \leq 2$		$0.08 < W$	Define as spot defect							
Width(mm)	Length(mm)	Acceptable Qty																														
		A	B	C																												
$\Phi \leq 0.03$	Ignore	Ignore		Ignore																												
$0.03 < W \leq 0.05$	$L \leq 3.0$	$N \leq 2$																														
$0.05 < W \leq 0.08$	$L \leq 2.0$	$N \leq 2$																														
$0.08 < W$	Define as spot defect																															
3.0	Polariz Bubbl	<table border="1"> <thead> <tr> <th rowspan="2"></th> <th colspan="3">Acceptable Qty</th> </tr> <tr> <th>A</th> <th>B</th> <th>C</th> </tr> </thead> <tbody> <tr> <td>$0.2 < \Phi \leq 0.4$</td> <td colspan="2">Ignore</td> <td rowspan="4">Ignore</td> </tr> <tr> <td>$0.4 < \Phi \leq 0.6$</td> <td colspan="2">2 (distance $\geq 10\text{mm}$)</td> </tr> <tr> <td>$0.6 < \Phi$</td> <td colspan="2">1</td> </tr> <tr> <td></td> <td colspan="2">0</td> </tr> </tbody> </table>		Acceptable Qty			A	B	C	$0.2 < \Phi \leq 0.4$	Ignore		Ignore	$0.4 < \Phi \leq 0.6$	2 (distance $\geq 10\text{mm}$)		$0.6 < \Phi$	1			0											
	Acceptable Qty																															
	A	B	C																													
$0.2 < \Phi \leq 0.4$	Ignore		Ignore																													
$0.4 < \Phi \leq 0.6$	2 (distance $\geq 10\text{mm}$)																															
$0.6 < \Phi$	1																															
	0																															
4.0	SMT	According to IPC-A-610C class II standard . Function defect and missing part are major defect ,the others are minor defect.																														
5.0	TP	<table border="1"> <tr> <td data-bbox="379 1111 571 1402" rowspan="5">TP bubble/ accidented spot</td> <td data-bbox="571 1111 1418 1402"> <table border="1"> <thead> <tr> <th rowspan="2">Size Φ (mm)</th> <th colspan="3">Acceptable Qty</th> </tr> <tr> <th>A</th> <th>B</th> <th>C</th> </tr> </thead> <tbody> <tr> <td>$\Phi \leq 0.1$</td> <td colspan="3">Ignore</td> </tr> <tr> <td>$0.1 < \Phi \leq 0.2$</td> <td colspan="3">2 (distance $\geq 10\text{mm}$)</td> </tr> <tr> <td>$0.2 < \Phi \leq 0.3$</td> <td colspan="3">1</td> </tr> <tr> <td>$0.3 < \Phi$</td> <td colspan="3">0</td> </tr> </tbody> </table> </td> </tr> <tr> <td data-bbox="379 1402 571 1505">Assembly deflection</td> <td colspan="4" data-bbox="571 1402 1418 1505">beyond the edge of backlight $\leq 0.15\text{mm}$</td> </tr> </table>	TP bubble/ accidented spot	<table border="1"> <thead> <tr> <th rowspan="2">Size Φ (mm)</th> <th colspan="3">Acceptable Qty</th> </tr> <tr> <th>A</th> <th>B</th> <th>C</th> </tr> </thead> <tbody> <tr> <td>$\Phi \leq 0.1$</td> <td colspan="3">Ignore</td> </tr> <tr> <td>$0.1 < \Phi \leq 0.2$</td> <td colspan="3">2 (distance $\geq 10\text{mm}$)</td> </tr> <tr> <td>$0.2 < \Phi \leq 0.3$</td> <td colspan="3">1</td> </tr> <tr> <td>$0.3 < \Phi$</td> <td colspan="3">0</td> </tr> </tbody> </table>	Size Φ (mm)	Acceptable Qty			A	B	C	$\Phi \leq 0.1$	Ignore			$0.1 < \Phi \leq 0.2$	2 (distance $\geq 10\text{mm}$)			$0.2 < \Phi \leq 0.3$	1			$0.3 < \Phi$	0			Assembly deflection	beyond the edge of backlight $\leq 0.15\text{mm}$			
TP bubble/ accidented spot	<table border="1"> <thead> <tr> <th rowspan="2">Size Φ (mm)</th> <th colspan="3">Acceptable Qty</th> </tr> <tr> <th>A</th> <th>B</th> <th>C</th> </tr> </thead> <tbody> <tr> <td>$\Phi \leq 0.1$</td> <td colspan="3">Ignore</td> </tr> <tr> <td>$0.1 < \Phi \leq 0.2$</td> <td colspan="3">2 (distance $\geq 10\text{mm}$)</td> </tr> <tr> <td>$0.2 < \Phi \leq 0.3$</td> <td colspan="3">1</td> </tr> <tr> <td>$0.3 < \Phi$</td> <td colspan="3">0</td> </tr> </tbody> </table>	Size Φ (mm)		Acceptable Qty			A	B	C	$\Phi \leq 0.1$	Ignore			$0.1 < \Phi \leq 0.2$	2 (distance $\geq 10\text{mm}$)			$0.2 < \Phi \leq 0.3$	1			$0.3 < \Phi$	0									
	Size Φ (mm)			Acceptable Qty																												
		A		B	C																											
	$\Phi \leq 0.1$	Ignore																														
	$0.1 < \Phi \leq 0.2$	2 (distance $\geq 10\text{mm}$)																														
$0.2 < \Phi \leq 0.3$	1																															
$0.3 < \Phi$	0																															
Assembly deflection	beyond the edge of backlight $\leq 0.15\text{mm}$																															

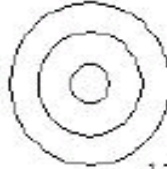
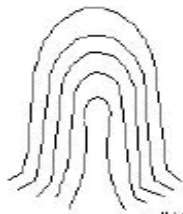

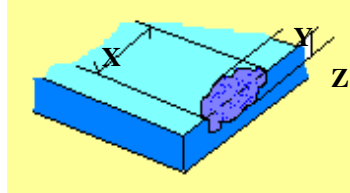
	Newton Ring		 <p>1 规律性</p>  <p>2 非规律性</p>  <p>似牛顿环</p>						
		<p>Newton Ring area > 1/3 TP area NG</p> <p>Newton Ring area ≤ 1/3 TP area OK</p>							
	Z: height	*Circuitry broken is not allowed.							
	TP edge broken X: length Y: width Z: height	<table border="1"> <thead> <tr> <th>X</th> <th>Y</th> <th>Z</th> </tr> </thead> <tbody> <tr> <td>X ≤ 6.0mm</td> <td>Y ≤ 2.0mm</td> <td>Z < LCD thickness</td> </tr> </tbody> </table> <p>* Circuitry broken is not allowed.</p>	X	Y	Z	X ≤ 6.0mm	Y ≤ 2.0mm	Z < LCD thickness	
X	Y	Z							
X ≤ 6.0mm	Y ≤ 2.0mm	Z < LCD thickness							

Criteria (functional items)

Number	Items	Criteria (mm)
1	No display	Not allowed
2	Missing segment	Not allowed
3	Short	Not allowed
4	Backlight no lighting	Not allowed
5	TP no function	Not allowed

2.0 RELIABILITY TEST

NO	ITEM	CONDITION	STANDARD
1	High Temp. Storage	70°C, 12 hours	1. Functional test is OK. Missing Segment, short, unclear segment, non-display, display abnormally and liquid crystal leak are un-allowed. 2. No low temperature
2	Low Temp. Storage	-20°C, 12 hours	
3	High Temp. Operation	60°C, 12 hours	
4	Low Temp. Operation	-20°C, 12 hours	



5	High temperature and high Humidity storage	40°C, 90%RH , 12 hours	
6	Thermal and cold shock	Static state, -20°C (30 Min) ~70°C (30 Min) ~ -20°C (30Min) , packaging, 10 cycles	
7	Vibration test	Packaging, Frequency : 10-55Hz Amplitude : 1.0mm, Each direction on X,Y axe 0.5 hours, circle 2 hours	1. Function test is OK. 2. No glass crack, chipped glass, end seal loose and fall, epoxy frame crack and so on. 3. No structure loose and fall.
8	Dropping test	Pack products into the carton box. Drop it from 80cm height to ground. Once for each side of the carton	

NOTE:

- 2.1 The reliability items will be fully performed in new sample qualification,
- 2.2 The reliability status will be tested as monitor during mass production. Individual reliability test shall be performed by lot , Moreover, the individual reliability item shall be decided according to reliability plan.
- 2.3 All samples are inspected after keeping in the room with normal temperature and humidity for 2 hours or above.
- 2.4 Vibration test: It is not necessary to test for those products without assembly frame , back light ,PCB and so on.
- 2.5 Dropping test : It is necessary for affirming new package.
- 2.6 For the high temperature and high humidity test, pure water of over 10 M Ω .cm should be used.
- 2.7 Each test item applies for test LCM only once .Then tested LCM cannot be used again in any other test item.
- 2.8 The quantity of LCM examination for each test item is 5pcs to 10pcs.

3.0 Safety instructions

- 3.1 If the LCD panel breaks, be careful not to get any liquid crystal substance in your mouth.
- 3.2 If the liquid crystal substance touches your skin or clothes, please wash it off immediately by using soap and water.

4.0 Handling Precautions

- 4.1 Avoid static electricity damaging the LSI.
- 4.2 Do not remove the panel or frame from the module .
- 4.3 The polarizing plate of the display is very fragile . So, please handle it very carefully.
- 4.4 Do not wipe the polarizing plate with a dry cloth, as it may easily scratch the surface of the plate.
- 4.5 The color tone of display and background of LCM has the possibility to be changed in the storage temperature range.
- 4.6 Pay attention to the working environment, as the element may be destroyed by static electricity.
 - Be sure to ground human body and electric appliance during work.
 - Avoid working in a dry environment to minimize the generations of static electricity.
 - Static electricity may be generated when the protective film is fast peeled off.
- 4.7 When soldering the terminal of LCM, make certain the AC power source of soldering iron does not leak.
- 4.8 If the display surface becomes contaminated ,breathe on the surface and gently wipe it with a soft-dry- clean cloth .If it is heavily contaminated ,moisten cloth with the following solvent(ex:Ethyl alcohol).Solvents other than those above-mentioned may damage the polarizer(Especially ,do not use them .ex: Water / Ketone)

5.0 Operation instructions

- 5.1 It is recommended to drive the LCD within the specified voltage limits, try to adjust the operating voltage for the optimal contrast, the color and contrast of LCD panel will varies at different temperature.
- 5.2 Response time is greatly delayed at low operating temperature range. However, this does not mean the LCD will be out of the order, It will recover when it returns to the specified temperature range.
- 5.3 If the display area is pushed hard during operation, the display will become abnormal.
- 5.4 Do not operate the LCD at the environments over the specified conditions, this may cause damage on the LCD and shorten the lifetime.

6.0 Storage instructions:

- 6.1 Store LCDs in a sealed polyethylene bag.
- 6.2 Store LCDs in a dark place, Do not expose to sunlight or fluorescent light. Keep the temperature between 0°C and 35°C.



6.3 Avoid the polarizer touch any other object, (It is recommended to store them in the container in which they were shipped.)

7.0 Limited Warranty

- 7.1 RISHI will replace or repair any of its LCD modules, which are found to be defective, when inspected in accordance with LEAD LCM acceptance standards (copies available upon request) for a period of 12 months from ink- print date on product
- 7.2 Any defects must be returned to RISHI within 60 days since ship-out. Confirmation of such date shall be based on freight documents. The warranty liability of RISHI limited to repair and/or replacement on defects above (7.1,7.2)
- 7.3 No warranty can be granted if the precautions stated above have been disregarded. The typical samples are as below:
- LCD glass crack/break
 - PCB outlet is damaged or modified.
 - PCB conductors damaged.
 - Circuit modified with by grinding, engraving or painting varnish.
 - FPC crack
- 7.4 Modules must be returned with sufficient description of the failures of defects. Any connectors or cable installed by the customer must be removed completely without damaging the PCB outlet, conductors and terminals.
- Modules must be packed with the container in which they were shipped.