



## APPROVAL SHEET

### 承认书

记录编号:

版本: v0.3

Customer 客户名称	
Part NO. 产品型号	LCDT283701
Product type 产品内容	Mode: Transmissive type .Normally white. TFT LCD Module LCD Module: Graphic 240RGB*320Dot-matrix
Remarks 备注栏	<input type="checkbox"/> APPROVAL FOR SEPCIFICATIONS ONLY <input checked="" type="checkbox"/> APPROVAL FOR SEPCIFICATIONS AND SAMPLE
Signature by Customer: 客户确认签章	

核准	审核	定制

### 客户确认

核准	审核	审核



## TABLE OF Contents

1. General Description.....	3
2. Features.....	3
3. Mechanical Specification.....	3
4. Mechanical Dimension.....	4
5. Maximum Ratings.....	5
6. Electrical Characteristics.....	5
7. Backlight Characteristic.....	5
8. Module Function Description.....	7
9. Electro-optical Characteristics.....	12
10. Reliability.....	16
11. Inspection Standards.....	17
12. Precautions For Using LCD Modules.....	21
13. Revision History.....	22



## 1. General Description

LCDT283701 is a 240RGB\*320 dots matrix TFT LCD module. It has a TFT panel composed of 720 sources and 320 gates. The LCM can be easily accessed by micro-controller.

## 2. Features

Display Mode	Transmissive
	a-TFT
Display Format	Graphic 240RGB*320 Dot-matrix
Input Data	8 /16bits parallel interface
Viewing Direction	12 o'clock
Drive	ILI9341/ST7789

## 3. Mechanical Specification

Item	Specifications	Unit
Dimensional outline	50.00(W)*69.20(H)*3.55+/-0.1(T) (FPC not include)	mm
Resolution	240RGB*320	dots
LCD Active area	43.20(W)*57.60(H)	mm
Pixel size	0.180(W)*0.180(H)	mm

## 4. Mechanical Dimension



# 深圳市艾斯迪科技有限公司

SHENZHEN LCD TECHNOLOGY COMPANY LIMITED

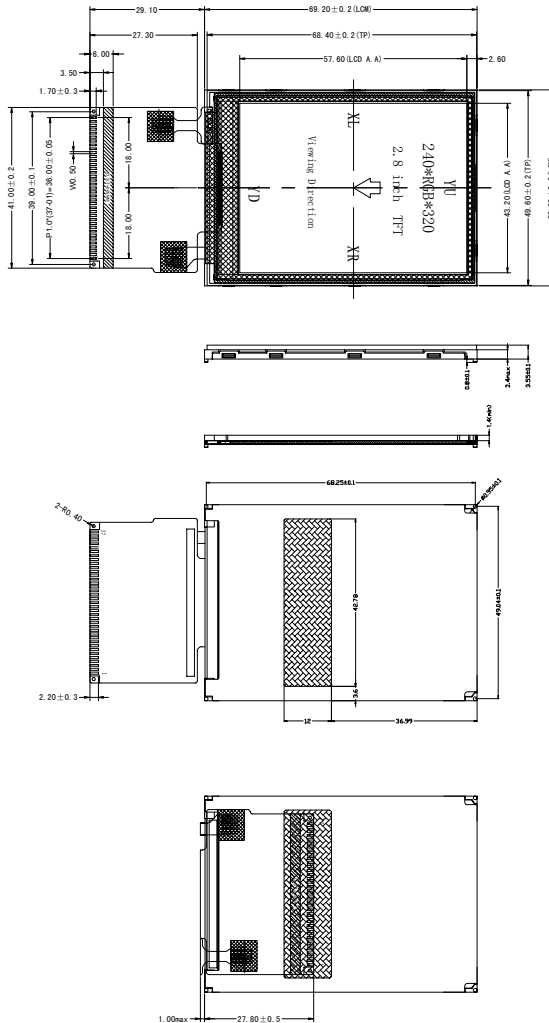

Pin	Pin Name
1	DB0
2	DB1
3	DB2
4	DB3
5	GND
6	VDD1
7	/CS
8	RS
9	/MR
10	/RD
11	NC
12	X+(XR)
13	Y+(YD)
14	X-(XL)
15	Y-(YU)
16	LED-A
17	LED-K1
18	LED-K2
19	LED-K3
20	LED-K4
21	FWARK
22	DS4
23	DS8
24	DS9
25	DS10
26	DS11
27	DS12
28	DS13
29	DS14
30	DS15
31	/RESET
32	VDD
33	VDD1
34	GND
35	DS5
36	DS6
37	DS7

### 技术要求:

- 1) 液晶显示模式: 2.8" TFT Transmissive
- 2) 显示颜色: 262K
- 3) 视角: 12 °/CLOCK
- 4) 点阵: 240 (RGB) X 320 DOTS
- 5) PIXEL PITCH: 0.18 X 0.18 mm
- 6) 驱动芯片型号: IL19341 ST7789
- 7) 背光: LED WHITE(X3), 并驱
- 8) 工作温度: -20° C ~ +70° C  
储存温度: -30° C ~ +80° C
- 9) 产品符合: ROHS标准

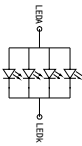

BL CIRCUIT DIAGRAM

产品型号:	LCM外形图		确认:
部品型号:	v0.3	单位: MM	审核:
日期:	2014.01.17	比例: 1:1	设计:
UNMARKED TOLERANCE:	± 0.20 mm		页码: 1 OF 1



## 5. Maximum Ratings

Item	Symbol	Min	Max	Unit	Note
Supply voltage	V	-0.3	4.6	V	
Operating temperature	V <sub>T</sub>	-0.3	V <sub>CC</sub> +0.3	V	
Storage temperature	T <sub>OPR</sub>	-20	70	°C	
Storage temperature	T <sub>STR</sub>	-30	80	°C	

## 6. Electrical Characteristics

Item		Symbol	Condition	Min.	Typ.	Max.	Unit
Supply voltage	Logic	V <sub>CC</sub>		2.7	2.8	3.3	V
Input Voltage	H level	T <sub>IH</sub>		0.8*IOVCC		IOVCC	V
	L level	T <sub>IL</sub>		-0.3		0.2* IOVCC	
Storage temperature		I <sub>DD</sub>	With internal voltage generation V <sub>CC</sub> =2.8V; T <sub>emp</sub> =25°C			TBD	mA

## 7. Backlight Characteristic

Item	Symbol	Min	Typical	Max	Unit
LED module Forward voltage	V <sub>LED</sub>	3.0	3.2	3.4	V
LED module current	V <sub>LED</sub>		90		mA
L/G Surface Luminance ★1	L <sub>S</sub>	3200			Cd/m <sup>3</sup>
LCM Surface brightness uniform ★2	L <sub>D</sub>	80			%

★ 1Test condition is:

- (a) Center point on active area.
- (b)Best Contrast.

★2Uniform measure condition:

- (1)Measure 9 point. Measure location show below;
- (2)Uniform=(Min. brightness /Max. brightness)\*100%



(3) Best Contrast.

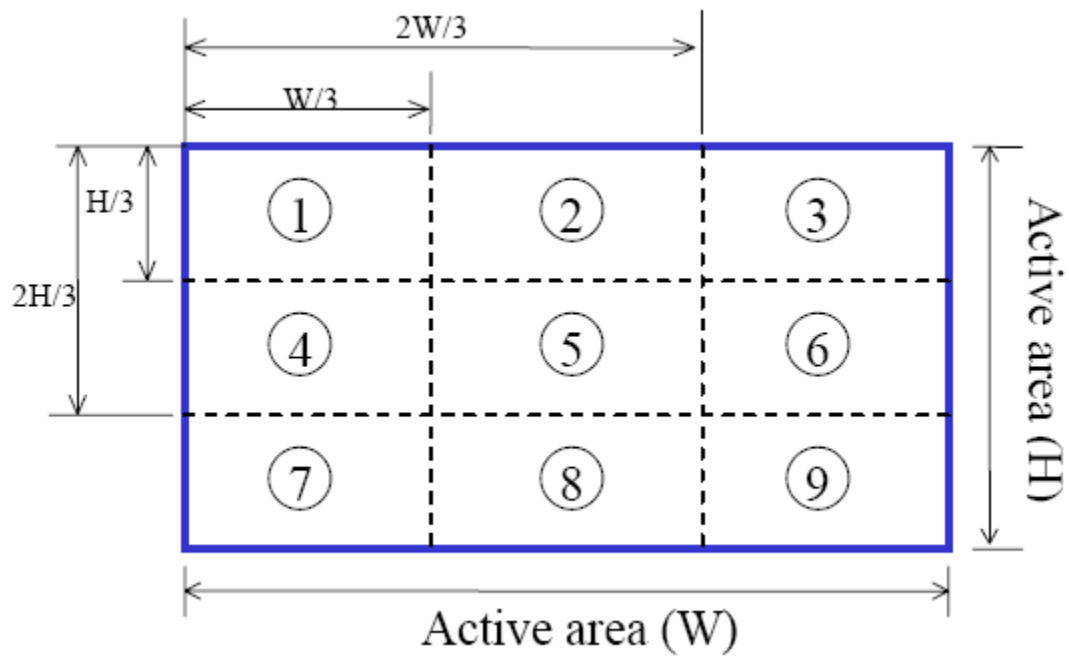



## 8. Module Function Description

### 8.1 Pin Descriptions

PIN No.	Symbol	Description
1-4	DB0-DB3	Data bus <i>Fix to GND level when not in use</i> (数据线, 不用时接地)
5	GND	Ground (接地脚)
6	IOVCC	Power supply for LCM (2.8V-3.3V) (屏供电脚)
7	/CS	Chip select pin ("Low" enable) (屏驱动芯片片选脚, 低电平有效)
8	RS	This pin is used to select "Data or Command" in the parallel interface (用于并口的数据或者寄存器选择) When RS= '1', data is selected.(选择数据) When RS= '0', command is selected.(选择寄存器)
9	/WR	Serves as a write signal and <i>Fix to IOVCC level when not in use.</i> (并口的写控制脚, 不用时接 IOVCC)
10	/RD	Serves as a read signal and MCU read data at the rising edge. <i>Fix to IOVCC level when not in use.</i> (并口的读控制脚, 不用时接IOVCC)
11	NC	No connection (悬空)
12	XR	Touch panel control pin (触摸屏控制脚)
13	YD	Touch panel control pin (触摸屏控制脚)
14	XL	Touch panel control pin (触摸屏控制脚)
15	YU	Touch panel control pin (触摸屏控制脚)



## 深圳市艾斯迪科技有限公司

SHENZHEN LCD TECHNOLOGY COMPANY LIMITED

16	LED-A	Anode of Backlight (3.0V-3.4V Typical:3.2V) (背光正极供电脚, 电压范围:3.0-3.4V, 典型值:3.2V)
17	LED-K1	Cathode of Backlight (背光负极供电脚)
18	LED-K2	Cathode of Backlight (背光负极供电脚)
19	LED-K3	Cathode of Backlight (背光负极供电脚)
20	LED-K4	Cathode of Backlight (背光负极供电脚)
21	FMARK	Tearing effect output pin to synchronize MPU to frame writing, activated by S/W command. When this pin is not activated, this pin is low. If not used, open this pin. (帧同信号, 不用时悬空)
22	DB4	Data bus <i>Fix to GND level when not in use</i> (数据线, 不用时接地)
23-30	DB8-DB15	Data bus <i>Fix to GND level when not in use</i> (数据线, 不用时接地)
31	/RESET	LCM Reset pin Signal is active low. (屏复位脚, 低电平复位)
32	VCC	Power supply for LCM (2.8V-3.3V) (屏供电脚)
33	I0VCC	Power supply for LCM (2.8V-3.3V) (屏供电脚)
34	GMD	Ground (接地脚)
35-37	DB5-DB7	Data bus <i>Fix to GND level when not in use</i> (数据线, 不用时接地)





关于供电说明：

**IOVCC 和 VCC 连一起，用 2.8V-3.3V 供电；背光 LED 可以单独供电 (3.0-3.4 V)，也可以和 VCC 共用一组电压 (A 为正接 VCC，K 连一起作为负接地)。**

## **8.2Timing characteristics.**



**深圳市艾斯迪科技有限公司**  
SHENZHEN LCD TECHNOLOGY COMPANY LIMITED

**18.3.2 Display Parallel 18/16/9/8-bit Interface Timing Characteristics(8080- II system)**

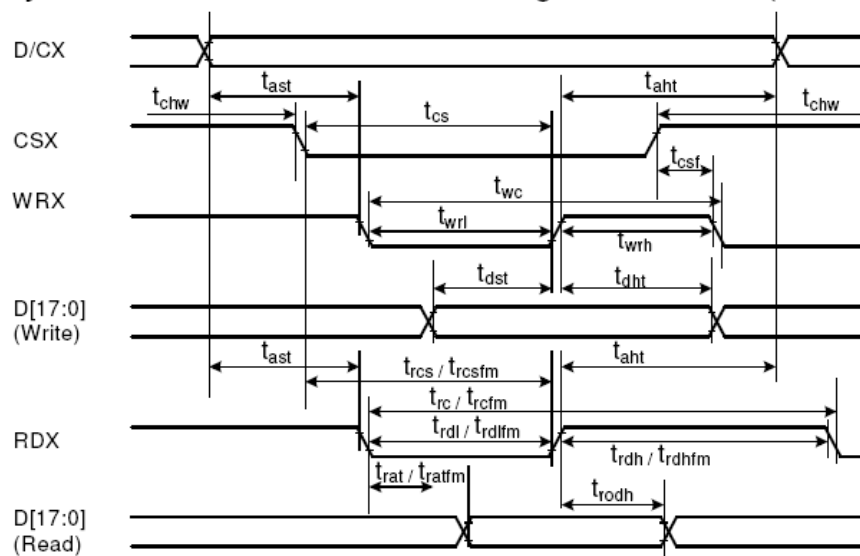

Signal	Symbol	Parameter	min	max	Unit	Description
DCX	tast	Address setup time	0	-	ns	
	taht	Address hold time (Write/Read)	0	-	ns	
CSX	tchw	CSX "H" pulse width	0	-	ns	
	tcs	Chip Select setup time (Write)	15	-	ns	
	trcs	Chip Select setup time (Read ID)	45	-	ns	
	trcsfm	Chip Select setup time (Read FM)	355	-	ns	
	tcsf	Chip Select Wait time (Write/Read)	10	-	ns	
WRX	twc	Write cycle	66	-	ns	
	twrh	Write Control pulse H duration	15	-	ns	
	twrl	Write Control pulse L duration	15	-	ns	
RDX (FM)	trcfm	Read Cycle (FM)	450	-	ns	
	trdhfm	Read Control H duration (FM)	90	-	ns	
	trdlfm	Read Control L duration (FM)	355	-	ns	
RDX (ID)	trc	Read cycle (ID)	160	-	ns	
	trdh	Read Control pulse H duration	90	-	ns	
	trdl	Read Control pulse L duration	45	-	ns	
D[17:0], D[17:10]&D[8:1], D[17:10], D[17:9]	tdst	Write data setup time	10	-	ns	For maximum CL=30pF For minimum CL=8pF
	tdht	Write data hold time	10	-	ns	
	trat	Read access time	-	40	ns	
	tratfm	Read access time	-	340	ns	
	trodh	Read output disable time	20	80	ns	

Note:  $T_a = -30$  to  $70$  °C,  $V_{DDI}=1.65V$  to  $3.3V$ ,  $V_{CI}=2.5V$  to  $3.3V$ ,  $V_{SS}=0V$ .

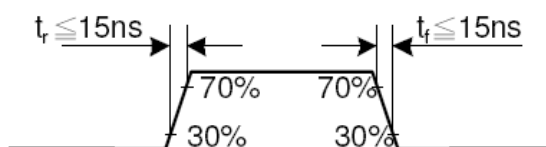



**深圳市艾斯迪科技有限公司**  
SHENZHEN LCD TECHNOLOGY COMPANY LIMITED

CSX timings :

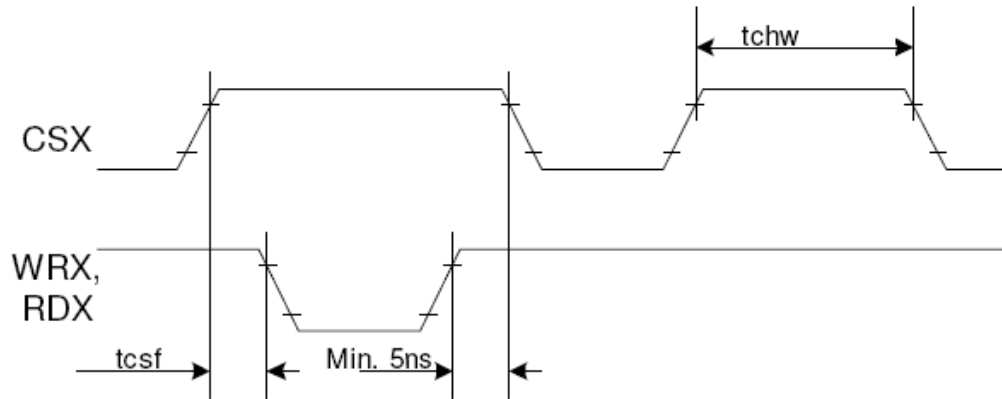

*Note: Logic high and low levels are specified as 30% and 70% of VDDI for Input signals.*

Write to read or read to write timings:

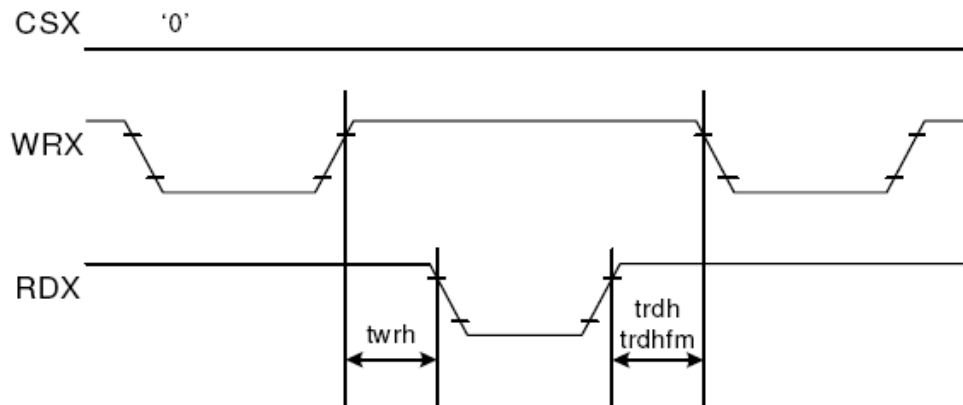

*Note: Logic high and low levels are specified as 30% and 70% of VDDI for Input signals.*



## 9. Electro-optical Characteristics

Item	Symbol	Conditions	Temp	Min.	Typ.	Max.	Unit	Note
Response Time	$T_R$	$\theta = \phi = 0$	25°C		TBD	TBD	msec	NOTE2
	$T_F$				TBD	TBD		
Viewing Angle Range	$\phi = 0^\circ (6'' )$	$\phi = 90^\circ (3'' )$		$\phi = 180^\circ (12'' )$		$\phi = 270^\circ (9'' )$		NOTE3
$\theta (25^\circ\text{C}) CR \geq 10$	TBD	TBD		TBD		TBD		NOTE3

The above “viewing angle” is the measuring position with the largest contrast ratio. Not for good image quality. Viewing direction for good image quality is 12 O’clock.

- For panel only
- Electro-Optical Characteristics Test Method

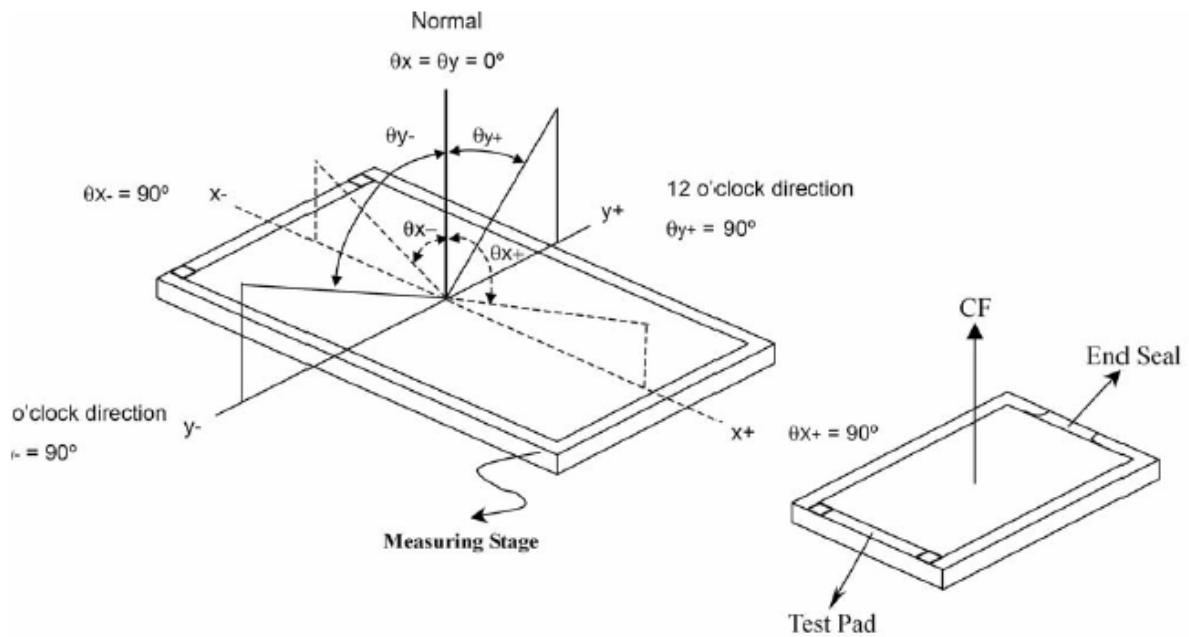



$$V_{op} = (V_{10, ON} + V_{90, OFF})/2$$

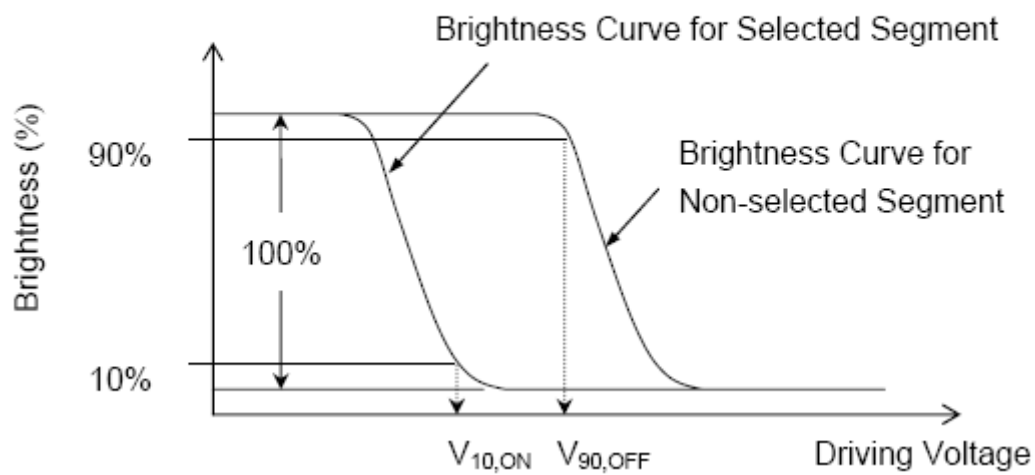

**.Note2.Definition of Optical Response Time:**

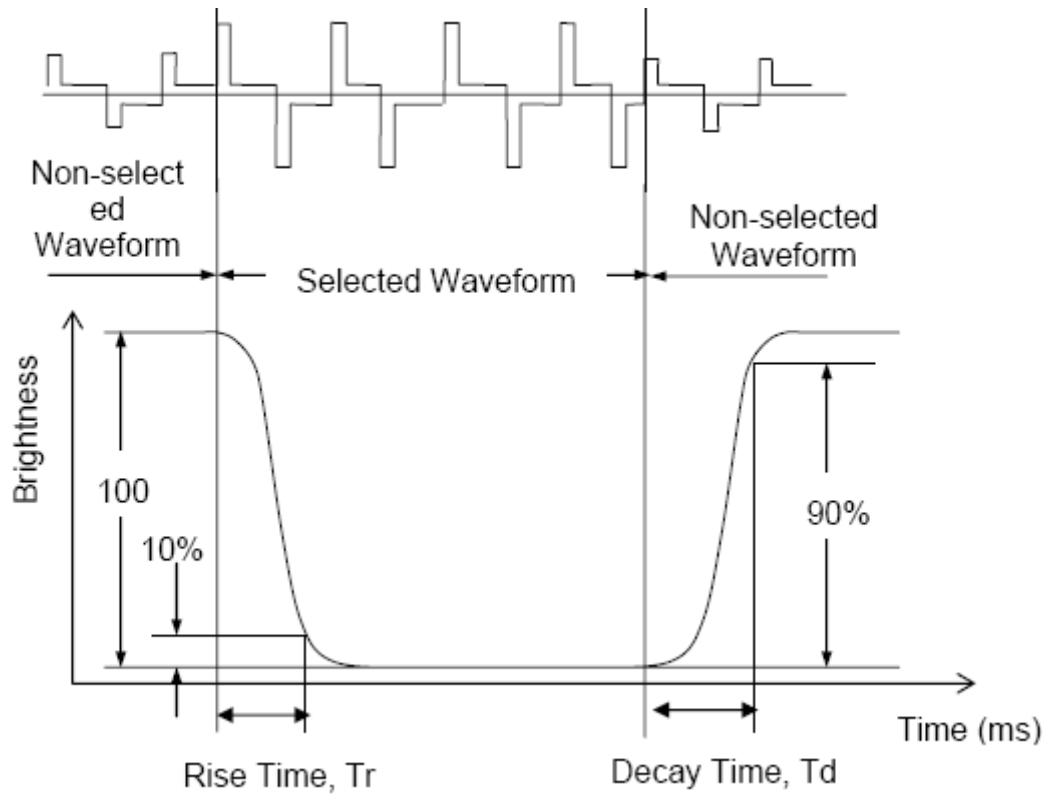

**.Note3.Definition of Viewing Angle  $\theta$  and  $\phi$  :**

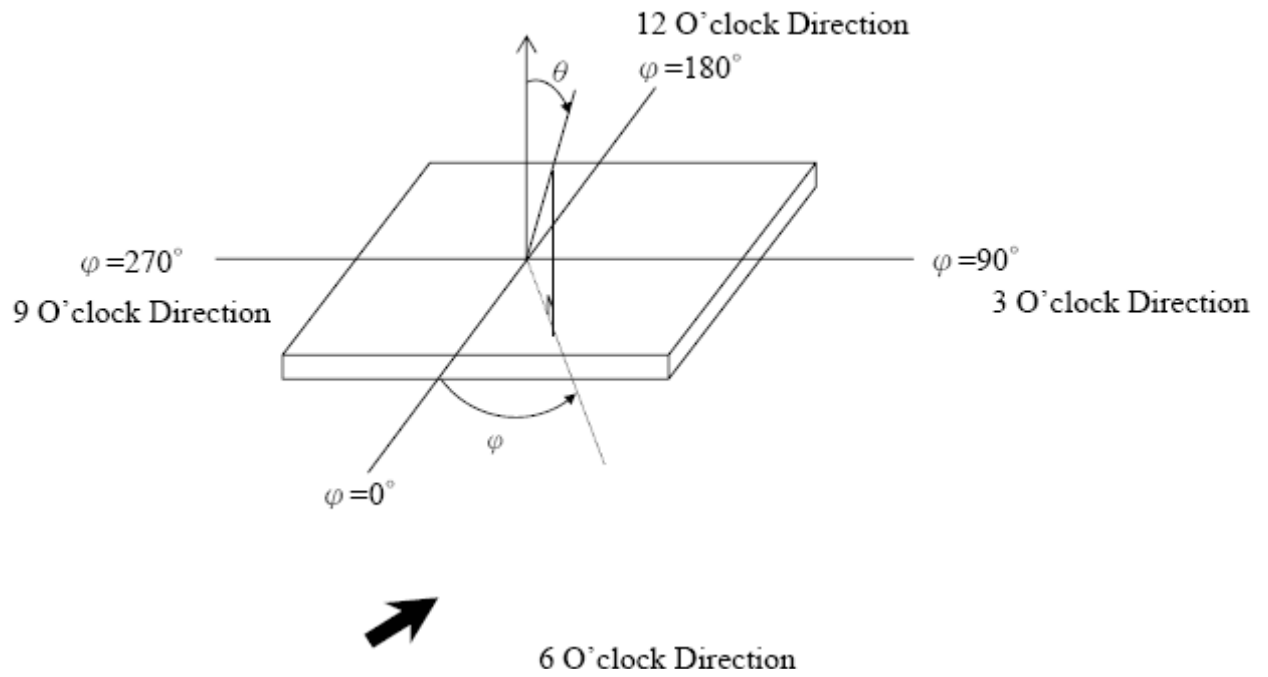

**Note4. Definition of Contrast ratio (CR):**



$$CR = \frac{\text{Brightness of Non-selected Segment (B2)}}{\text{Brightness of Selected Segment (B1)}}$$

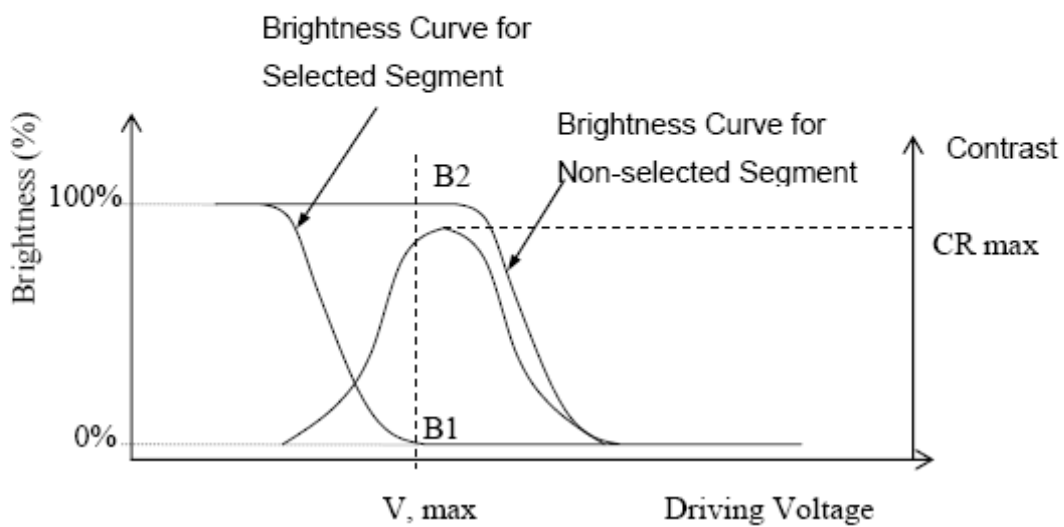

## 10. Reliability

### 10.1Mtbf

The LCD module shall be designed to meet a minimum MTBF value of 50000 hours with normal

### 10.2Test condition

NO.	ITEM	CONDITION	CRITERION
1	High Temperature Non-Operating Test	80°C*240Hrs	<ul style="list-style-type: none"> <li>◦ No Defect Of Operational Function In Room Temperature Are Allowable</li> <li>◦ IDD of LCM in Pre-and Post-Test Should Follow Specification</li> </ul>
2	Low Temperature Non-Operating Test	-30°C*240Hrs	
3	High Temperature/Humidity Non Operating Test	60°C*90%RH*240Hrs	
4	High Temperature Operating Test	70°C*240Hrs	
5	Low Temperature Operating Test	-20°C*240Hrs	
6	Thermal Shock Test	-20°C (30Min) ↔70°C (30Min) *10CYCLES	

Notes:

1. Judgments should be made after exposure in room temperature for two hours.
2. The distill water is used for the high temperature/humidity test.
3. The sample above is individually for every reliability tests condition.





## 11. Inspection standards

1. AQL (Acceptable Quality Level)

AQL of major and minor defect.

	MAJOR DEFECT	MINOR DEFECT
AQL	0.65	1.5

### 2. Basic conditions for inspection

The LCM face to us, in normal environment, the lux is  $1000 \pm 200$ . (Darkroom's lux:  $100 \pm 50$ ), About an angle of incidence  $30^\circ$ , a distance of 30 cm with an angle of  $45 \pm 10^\circ$  to check the products without uncovering the film!

(As shown below)

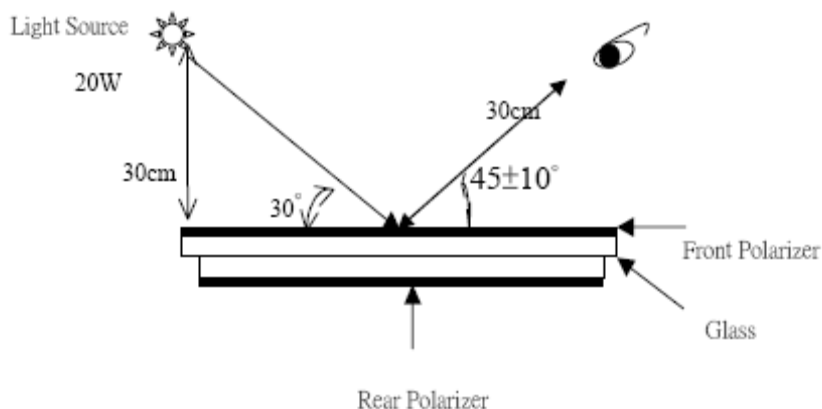

### 3. Inspection item and criteria

#### 3.1 Visual inspection criterion in immobility

##### 3.1.1 Glass defect

NO	Defect item	Criteria	Remark
1	Dimension Unconformity (Major defect)	By Engineering Drawing	
2	Cracks (Major defect)	1. Linear cracks panel 2. Nonlinear crack contrast by limited sample <b>【Reject】</b>	
3	Glass extrude the conductive area (minor defect)	a: disregards and no influence assemblage. 1) $b \leq 1/3 \text{ Pin width (non bonding)}$	A: Length, b: Width

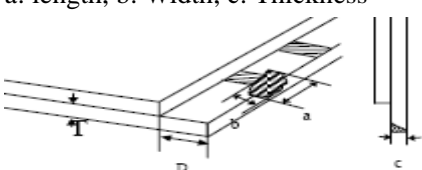
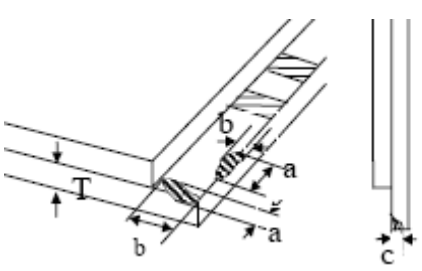
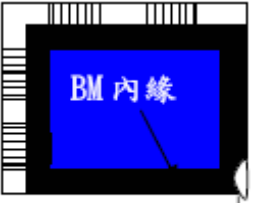
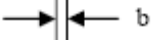

**深圳市艾斯迪科技有限公司**  
SHENZHEN LCD TECHNOLOGY COMPANY LIMITED

		area) 【Accept】 2)bonding area $\leq 0.5$ mm 【Accept】	
4	Pin-side ,conductive area damaged (minor defect)	(a c: disregards) $b \leq 1/3$ of effective length for bonding electrode 【Accept】	a: length, b: Width, c: Thickness 
5	Pin-side,non-conductive area damaged (minor defect)	1)Damage area don't touch the ITO (Including contraposition mark, except scribing mark) 【Accept】 2) $C < T$ $b \leq BM/3$ of width 【Accept】 3) $c = T$ b not touch the seal glue 【Accept】 4)a disregards	a: Length, b: Width c: Thickness 
6	Non-pin-side damage (minor defect)	$c < T$ 1)b exceeds $1/3BM$ 【Reject】 $c = T$ b not touch the seal glue 【Reject】	c: Thickness b: width of  damage 

3.1.2LCD appearance defect(View area)

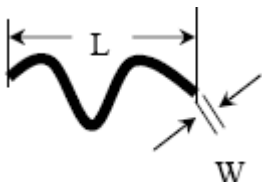
NO	Defect item	Criteria		Remark
		Specification	Allowable	
1	Fiber、 glass cratch、 polarizer scratch/folded (minor defect)	$W \leq 0.03$ mm	disregard	note1:L: Length, W: Width note2: disregard if out of AA 
		$0.03\text{mm} < W \leq 0.05\text{mm};$ $L \leq 3.0$ mm	2	
		$0.05\text{mm} < W \leq 0.1\text{mm};$ $L \leq 3.0$ mm	1	
		$W > 0.1\text{mm}; L > 3.0\text{mm}$	0	

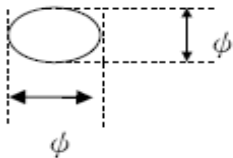

2	Polarizer bubble、 concave and convex (minor defect)	$\phi \leq 0.2\text{mm}$	disregard	note1: $\phi = (L+W)/2$ , L:Length, W :Width note2:disregard if out of AA
		$0.2\text{mm} < \phi \leq 0.3\text{mm}$	2	
		$0.3\text{mm} < \phi \leq 0.5\text{mm}$	1	
		$0.5\text{mm} < \phi$	0	
3	Black dots、dirty dots、 impurities、eye winker (minor defect)	$\phi \leq 0.15\text{mm}$	disregard	note2:disregard if out of AA 
		$0.15\text{mm} < \phi \leq 0.25\text{mm}$	2	
		$0.25\text{mm} < \phi \leq 0.3\text{mm}$	1	
		$0.3\text{mm} < \phi$	0	
4	Polarizer prick (minor defect)	$\phi \leq 0.1\text{mm}$	disregard	note1: $\phi = (L+W)/2$ , L=Length, W=Width note2:the distance between two dots>5mm
		$0.1\text{mm} < \phi \leq 0.25\text{mm}$	3	
		$\phi > 0.25\text{mm}$	0	

### 3.1.3FPC

NO	Defect item	Criteria		Remark
1	Copper screen peel (minor defect)	Copper screen peel 【Reject】		
2	No release tape or peel	No release tape or peel 【Reject】		
3	Dirty dot and impurity of FPC for customer using side (minor defect)	Specification	Allowable	Note1: Cannot have stride ITO impurities
		$\phi \leq 0.25\text{mm}$	2	
		$\phi > 0.25$	0	

### 3.1.4Black tape & Mara tape

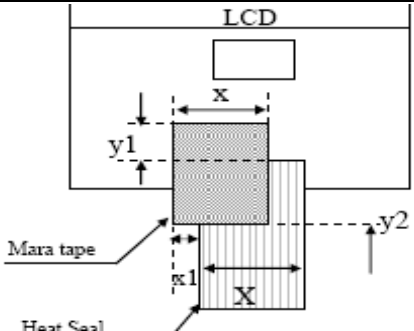
NO	Defect item	Criteria	Remark
1	FPC or H/S black tape (minor defect)	1. shift spec: 1) glue to the polarize 【Reject】 2) IC bare 【Reject】 2. left-and-right spec: 1) exceed of FPC edge or H-S edge 【Reject】 2) IC bare 【Reject】	



**深圳市艾斯迪科技有限公司**  
SHENZHEN LCD TECHNOLOGY COMPANY LIMITED

2	No black tape (major defect)	No black tape <b>【Reject】</b>	
3	Tape position mistake (minor defect)	Not by engineering drawing	
4	Mara tape defect (minor defect)	Peel before pulling the protecting film <b>【Reject】</b>	

### 3.1.5 Silicon and Taffy glue

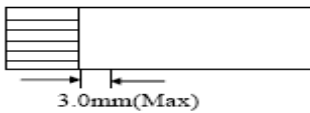
NO	Defect item	Criteria	Remark
1	Quantity of silicon (major defect)	Uncover the ITO and circuit area <b>【Reject】</b>	note: compared by engineering
2	Taffy glue (major defect)	1.Uncover the reveal copper area <b>【Reject】</b> 2.Cover layer 0.3mm(Min)~3.0mm(Max) <b>【Reject】</b>	note: if customer has special requirement, refer to the technical document 
3	Depth of glue covering (major defect)	Depth of glue covering overtop front Polarizer <b>【Reject】</b>	Except of the special requirement

### 3.2Electrical criteria

NO	Defect item	Criteria	Remark
1	No display (major defect)	No display <b>【Reject】</b>	
2	Missing line (major defect)	Missing line <b>【Reject】</b>	
3	Seg-com light and dark (major defect)	Seg-com light and dark <b>【Reject】</b>	ND filter 2% test
4	No display in immobility (major defect)	No display in immobility <b>【Reject】</b>	
5	Flicker of Pattern (major defect)	Flicker of Pattern <b>【Reject】</b>	
6	Mura (major defect)	ND filter 2% test	
7	Over current	Over current	

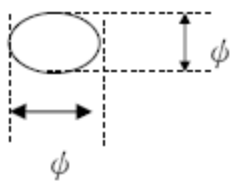
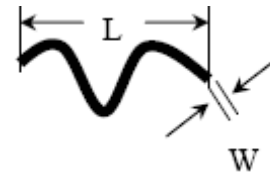

	(major defect)	<b>【Reject】</b>		
8	Voltage out of specification (major defect)	Voltage out of specification <b>【Reject】</b>		
9	Pattern blur, error code (major defect)	Pattern blur, error code <b>【Reject】</b>		
10	Dark light, Flicker (major defect)	Dark light, Flicker <b>【Reject】</b>		
11	Black/white dots 、 Dirty dots、 eye winker (major defect)	Specification	Allowable	Note1:disregard if out of AA 
		$\phi \leq 0.15\text{mm}$	disregard	
		$0.15\text{mm} < \phi \leq 0.25\text{mm}$	2	
		$0.25\text{mm} < \phi \leq 0.3\text{mm}$	1	
		$0.3\text{mm} < \phi$	0	
12	Fiber、glass crutch、Polarizer scratch/folded (major defect)	$W \leq 0.03\text{mm}$	disregard	Note1:L: Length, W: Width Note2: disregard if out of AA 
		$0.03\text{mm} < W \leq 0.05\text{mm}$ $L \leq 3.0\text{mm}$	2	
		$0.05\text{mm} < W \leq 0.1\text{mm}$ $L \leq 3.0\text{mm}$	1	
		$W > 0.1\text{mm}; L > 3.0\text{mm}$	0	

## 12.Precautions for using LCD modules.

### 12.1 Safety

- (1)Do not swallow any liquid crystal ,even if there is no proof that liquid crystal is poisonous.
- (2)If the LCD panel breaks, be careful not to get liquid crystal to touch your skin.
- (3)If skin is exposed to liquid crystal, wash the area thoroughly with alcohol or soap.

### 12.2Storage Conditions

- (4)Store the panel or module in a dark place where the temperature is  $23 \pm 5^{\circ}\text{C}$  and the humidity is below  $45 \pm 20\% \text{RH}$ .
- (5)Store in anti-static electricity container.
- (6)Store in clean environment, free from dust, active gas, and solvent.



- (7) Do not place the module near organics solvents or corrosive gases.
- (8) Do not crush, shake, or jolt the module.

### 12.3 Handling Precautions

- (9) Avoid static electricity, which can damage the CMOS LSI.
- (10) The polarizing plate of the display is very fragile, please handle it very carefully.
- (11) Do not give external shock.
- (12) Do not apply excessive force on the surface.
- (13) Do not wipe the polarizing plate with a dry cloth, as it may easily scratch the surface of the plate.
- (14) Do not use ketonic solvent & Aromatic solvent, use with a soft cloth soaked with a cleaning naphtha solvent.
- (15) Do not operate it above the absolute maximum rating.
- (16) Do not remove the panel or frame from the module.

### 12.4 Warranty

The period is within twelve months since the date of shipping out under normal using and storage conditions.

### 13. Revision history

Version	Revise record	Date
v0.0	Original version	2012-02-18
v0.1	Changed backlight	2012-05-15
v0.2	Changed touch panel	2013-06-02
v0.3	Changed backlight and touch panel	2014-09-05