

ELECTRICAL CHARACTERISTICS

ITEM	SYMBOL	CONDITION	MIN	TYP	MAX	UNIT
POWER SUPPLY VOLTAGE FOR LOGIC	VDD	Ta=25°C	4.5	5.0	5.5	V
POWER SUPPLY CURRENT FOR LOGIC	IDD	VDD-VSS=5V	-	16.0	25.0	mA
INPUT VOLTAGE	VIH	HIGH LEVEL	2.2	-	VDD	V
INPUT VOLTAGE	VIL	LOW LEVEL	-	-	0.6	V
OUTPUT VOLTAGE	VOH	HIGH LEVEL	2.4	-	-	V
OUTPUT VOLTAGE	VOL	LOW LEVEL	-	-	0.4	V
POWER SUPPLY VOLTAGE FOR LCD DRIVE (0°C TO 50°C)	VDD-Vo	VDD=5V Ta=25°C	12.2	13.6	14.5	V
POWER SUPPLY VOLTAGE FOR LCD DRIVE (-20°C TO +70°C)	VDD-Vo	VDD=5V Ta=25°C	12.6	14.1	14.9	V
LED BACKLIGHT VOLTAGE	Vf	If= 690	-	4.2	4.6	V
LED BACKLIGHT INTENSITY	Iv	If= 690	120	180	-	cd/m ²
LED POWER DISSIPATION	PAD	If= 990	-	-	5	W
CCFL DRIVING VOLTAGE	VCFL	Ta=25°C	-	300	-	V
CCFL FREQUENCY	fCFL	-	-	70	85	KHZ
CCFL CURRENT	ICFL	Ta=25°C	4	5	6	mA
CCFL STARTING DISCHARGE	VDCFL	Ta=5°C	(1000)	-	-	V

ELECTRIC MAXIMUM RATING

ITEM	SYMBOL	MIN	TYP	MAX	UNIT
POWER SUPPLY FOR LCD DRIVE	VDD-Vo	0	-	22.0	V
POWER SUPPLY FOR LOGIC	VDD-VSS	0	-	7.0	V
INPUT VOLTAGE	VI	VSS	-	VDD	V

TIMING CHARACTERISTICS

PARAMETER	SYMBOL	MIN	MAX	UNIT
C/D SETUP TIME	tCDS	100	-	ns
C/D HOLD TIME	tCDH	10	-	ns
CE, RD, WR PULSE WIDTH	tCE, tRD, tWR	80	-	ns
DATA SETUP TIME	tDS	80	-	ns
DATA HOLD TIME	tDH	40	-	ns
ACCESS TIME	tACC	-	150	ns
OUTPUT HOLD TIME	tOH	10	50	ns

BUS TIMING

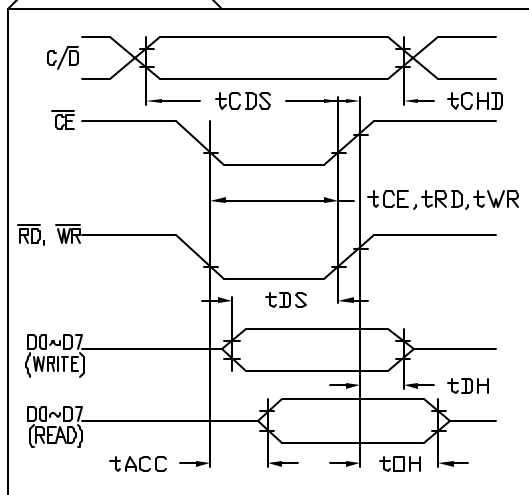

PIN CONFIGURATION

PIN #	SYMBOL	LEVEL	FUNCTION
1	FGND	-	FRAME GROUND (CONNECTED TO METAL BEZEL)
2	GND	0V	SIGNAL GROUND
3	VDD	+5V	POWER SUPPLY
4	Vo	-	CONTRAST ADJUSTMENT VOLTAGE
5	WR	L	DATA WRITE
6	RD	L	DATA READ
7	CE	L	CHIP ENABLE
8	C/D	H/L	WR="L", C/D="H": COMMAND WRITE C/D="L": DATA WRITE RD="L", C/D="H": COMMAND READ C/D="L": DATA READ
9	VEE	-15V	OUTPUT VOLTAGE FOR LCD DRIVING
10	RESET	L	CONTROL RESET (MODULE RESET)
11~18	DO~D7	H/L	DATA BUS
19	FS	H/L	FONT SELECT "H": 6 x 8 PIXEL/FONT "L": 8 x 8 PIXEL/FONT
20	N/C	-	NO CONNECTION

BLOCK DIAGRAM

