

LCM1210R2 Molded Chip Inductor

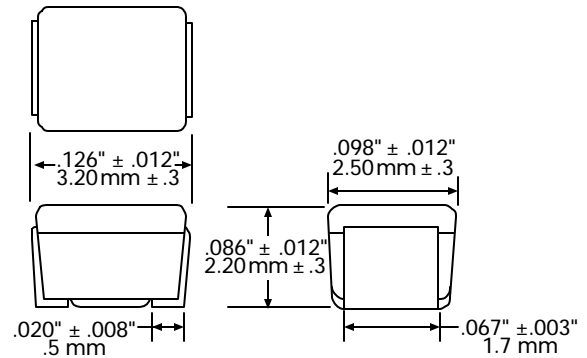
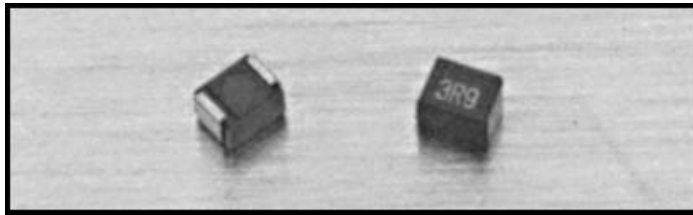
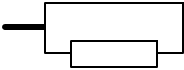

FEATURES

- Small molded chip inductor
- Special ferrite core ensures stable inductance against temperature humidity
- Broad inductance range
- High Q
- Highly reliable
- Excellent for flow, re-flow soldering, and soldering iron

APPLICATIONS

- TV's, VCR's, and audio equipment
- Disk drives and other computer peripherals
- Personal computers
- Electronic control boards for automobiles
- Telecommunication devices

CHARACTERISTICS

INDUCTANCE RANGE .01 μ H to 330 μ H

TOLERANCE 10% over entire range. 5% available upon request

CURRENT RATING Based on current flow and temperature rise of 20°C maximum at 80°C ambient temperature.

TESTING PROCEDURE Inductance, Q, and SRF measured by HP4191A Impedance Analyzer with 16092A Test Clip at specified frequency. DCR measured with digital milliohms meter.

DIELECTRIC STRENGTH 1000 volts DC between both terminals and package of coil for 5 seconds.

SOLDERABILITY 95% of the terminal is covered with solder. Please refer to page 2 for soldering recommendations.

SOLDERING HEAT: RESISTANCE 260°C for 10 seconds after 120°C preheat cycle for 5 minutes.

TEMPERATURE CHARACTERISTIC -25°C to 85°C where inductance and Q shall not change more than 20%.

STORAGE TEMPERATURE Store at normal temperature (-5°C to + 35°C) and normal humidity (85% RH max) in original package. Do not expose to direct sunlight or harmful gas. This inductor can maintain its characteristics in a storage temperature from -40°C to + 125°C for a period of 90 days.

HUMIDITY CHARACTERISTICS There is no change in performance at a humidity condition of 90-95% RH in 500 hours. Measurement shall be made after 1 hour stabilization at room temperature.

HEAT RESISTANCE Subjected to 100°C for 1000 hours without change in appearance, deformation, or performance. Measurement shall be made after 1 hour stabilization at room temperature.

THERMAL SHOCK Subjected to 100 cycles at the following temperature range without a change in performance: -25°C for 1 hour + 100°C for 1 hour. Measurement shall be made after 1 hour stabilization at room temperature.

TERMINAL STRENGTH Meets 3 lbs. pull test

RESISTANCE TO SOLVENT No change in appearance when dipped into alcohol or freon for 3 minutes.

MARKING Part is marked with inductance value in EIA code.

PACKAGING Tape and Reel only.