

LCM SPECIFICATIONS

(using)

LCM MODE: CHARACTER

PRODUCTION CODE: LCM1602A

REVISION: ver1.1

DATE: 2004/9/6

■ PHYSICAL DATA

Item	Contents	Unit
LCD type	STN	---
LCD duty	1/16	---
LCD bias	1/5	---
Viewing direction	6	---
Module size (W×H×T)	84.0 × 44.0 × 10.0/14.0 (with LED) MAX	mm
Viewing area (W×H)	61.0 × 17.0	mm
Character format	5 × 7 Dots with Cursor	dots
Character size	2.95 × 5.55	mm
Character pitch	3.55 × 5.95	mm
Dot size (W×H)	0.55 × 0.65	mm
Dot pitch (W×H)	0.6 × 0.7	mm

■ EXTERNAL DIMENSIONS

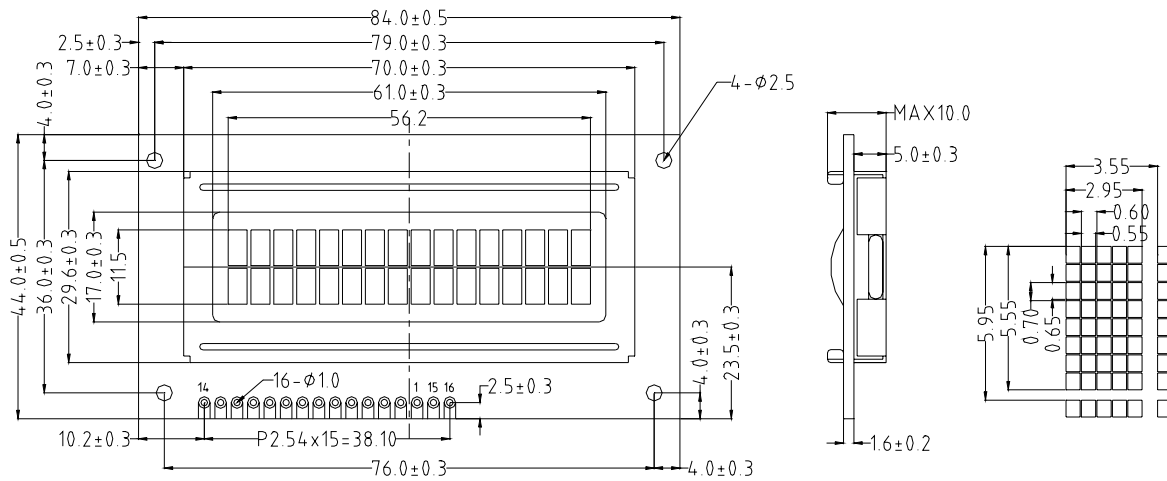

■ BLOCK DIAGRAM

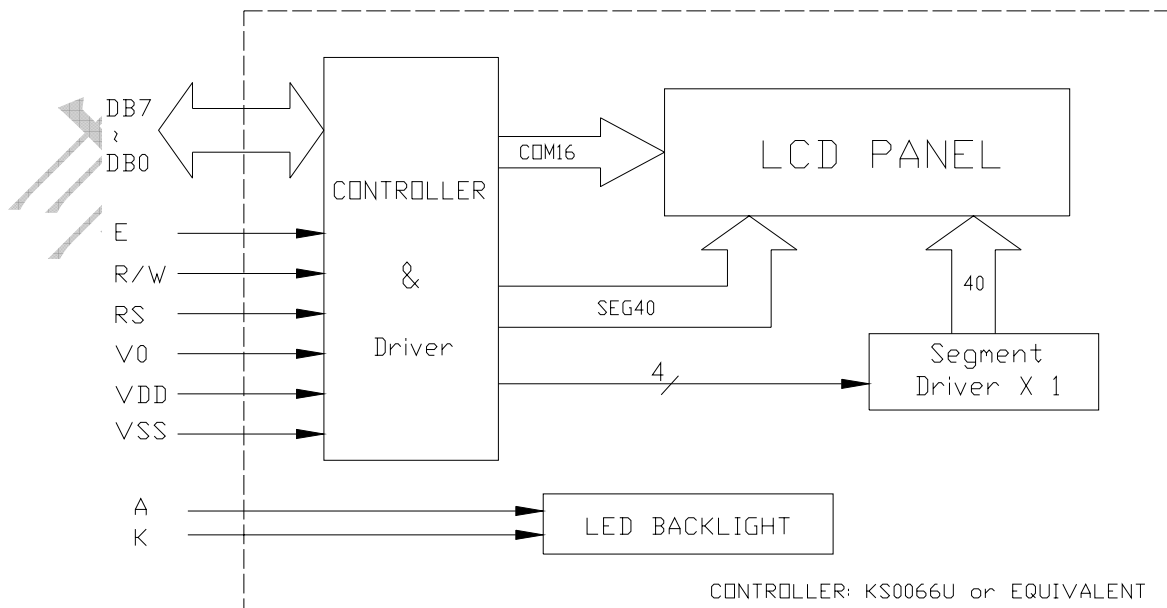

■ INTERFACE PIN CONNECTIONS

PIN	SYMBOL	SIGNAL DESCRIPTION
1	VSS	Ground(0V)
2	VDD	Logic voltage supply (+5.0V)
3	VO	LCD driver voltage input
4	RS	Data/Instruction register select
5	R/W	Read/Write select
6	E	Enable signal
7~14	DB0~DB7	Data bus line
15	A	LED backlight anode
16	K	LED backlight cathode

■ ABSOLUTE MAXIMUM RATINGS (Ta = 25° C)

PARAMETER	SYMBOL	MIN	MAX	Unit
Supply voltage for logic	VDD	-0.3	7.0	V
Supply voltage for LCD	VDD - VO	-0.3	13.5	V
Input voltage	VI	-0.3	VDD+0.3	V
Operating temperature	TOP	-20	70	°C
Storage temperature	TST	-30	80	°C

■ ELECTRICAL CHARACTERISTICS (VDD = +5V±10% , VSS = 0V, Ta = 25° C)

1. Electro-Optic Characteristics(module unit):

ITEM	SYMBOL	MIN	TYP	MAX	Unit	CONDITION
Input high voltage	V _{IH}	2.2	-	VDD	V	
Input low voltage	V _{IL}	-0.3	-	0.6	V	
Output high voltage	V _{OH}	2.4	-	VDD	V	
Output low voltage	V _{OL}	-	-	0.4	V	
Frame frequency	F _f	-	84.33	-	H _z	F _{osc} =270 KHz
Oscillation frequency	F _{osc}	-	270	-	KHz	VDD=5V Rf=91kΩ ±2%

Condition:TEMP=(23±3)°C

No.	ITEM	SYMBOL	MIN	TYP	MAX	Unit	CONDITION
1	Supply voltage(Logic)	VDD-VSS	4.5	5.0	5.5	V	
2	Supply current (Logic)	IDD		1.25		mA	VDD=5V
3	LCD operating voltage	VDD-VO		4.9		V	0°C
			4.5	4.7	5.0	V	25°C
				4.5		V	50°C
4	Response time	Ton		176		ms	
		Toff		77		ms	
5	Contrast	CR	3				
6	Viewing angel	12H	θ 1		54	Deg.	(CR≥3.0)
		6H	θ 2		43		
		3H	θ 3		60		
		9H	θ 4		60		

2. Electrical-optical Characteristics(LED unit):

ITEM	SYMBOL	MIN	TYP	MAX	Unit	CONDITION
Forward Voltage	VF		4.2		V	IF=100mA
Forward Current	IF		100		mA	
Reverse Voltage	VR		10		V	
Reverse Current	IR		0.1		mA	
Power Dissipation	PD		0.42		W	IF=100 mA
Luminous Intensity	LV		160		cd/m ²	IF=100 mA
Emission Wavelength	λ P	569	571	572	nm	IF=10 mA
Spectral Range	Δ λ		30		nm	Ta=25°C

■ RELIABILITY TEST

No.	ITEM	TEST CONDITION	EQUIPMENT	TEST RESULT
1	High Temp Storage	Temp:70±2°C Time:96h Restore:24h	Tenny	Passed
2	Low Temp Storage	Temp:-20±3°C ime:96h Restore:24h	Tenny	Passed
3	High Temp Static drive	Temp:50±2°C Vop:5V Time:24h Restore:24h	Tenny	Passed
4	Low Temp Static drive	Temp:0±3°C Vop:5V Time:24h Restore:24h	Tenny	Passed
5	High Temp High Hum Storage	Temp:40±2°C Hum:95%Rh Time:96h Restore:24h	Tenny	Passed
6	Thermal Shock	Temp:(°C) 70 25 -20 30 5 30 5 5 Cycles Restore:24h	Tenny	Passed

■ TIMING CHARACTERISTICS(VDD=4.5 to 5.5V)

Write operation and Read operation

ITEM	SYMBOL	MIN	TYP	MAX	Unit
Enable Cycle Time	T_{CYCLE}	400	--	--	nS
Enable Pulse Width	P_{WEH}	150	--	--	nS
Enable Rise & Fall Time	T_{ER}, T_{EF}	--	--	25	nS
Address Set-Up Time	T_{AS}	30	--	--	nS
Address Hold Time	T_{AH}	10	--	--	nS
Data Set-Up Time	T_{DSW}	40	--	--	nS
Data Hold Time	T_H	10	--	--	nS

ITEM	SYMBOL	MIN	TYP	MAX	Unit
Enable Cycle Time	T_{CYCLE}	400	--	--	nS
Enable Pulse Width	P_{WEH}	150	--	--	nS
Enable Rise & Fall Time	T_{ER}, T_{EF}	-	--	25	nS
Address Set-Up Time	T_{AS}	30	--	--	nS
Address Hold Time	T_{AH}	10	--	--	nS
Data Output Delay Time	T_{DSW}	-	--	100	nS
Data Hold Time	T_H	20	--	--	nS

Write Operation:

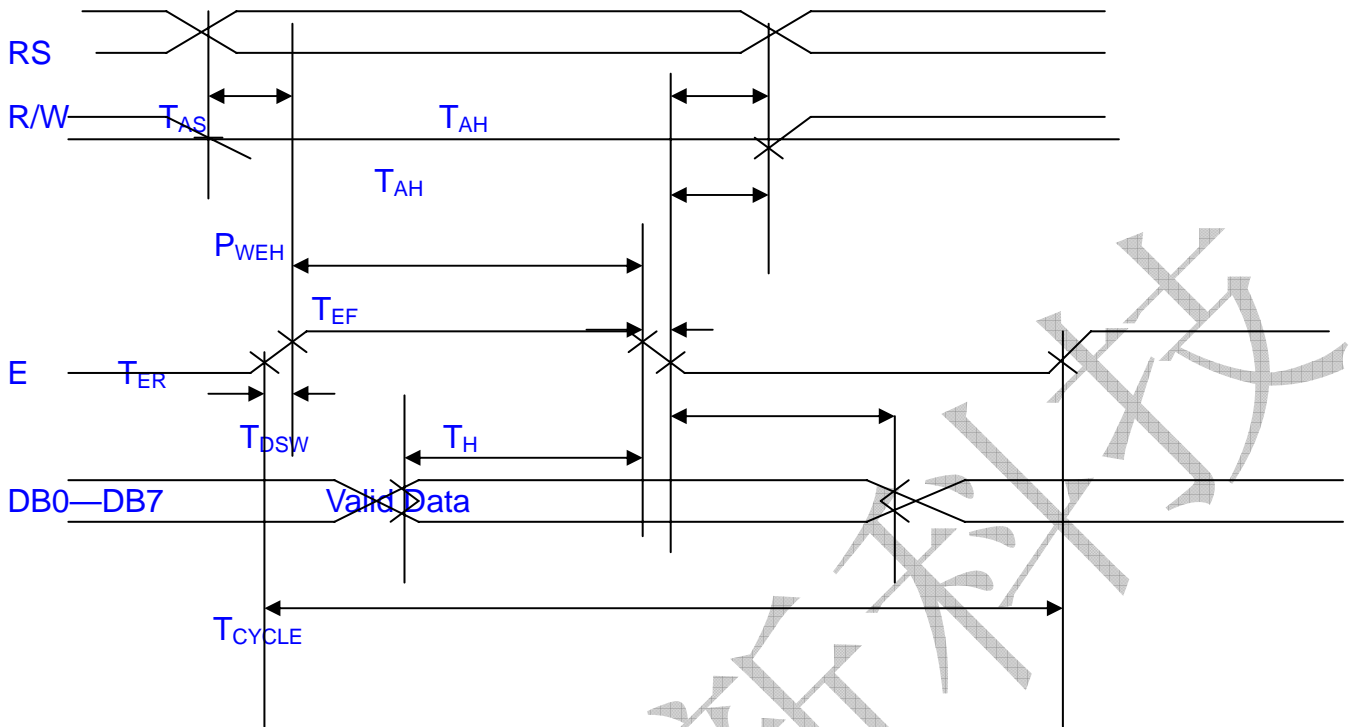

Read Operation

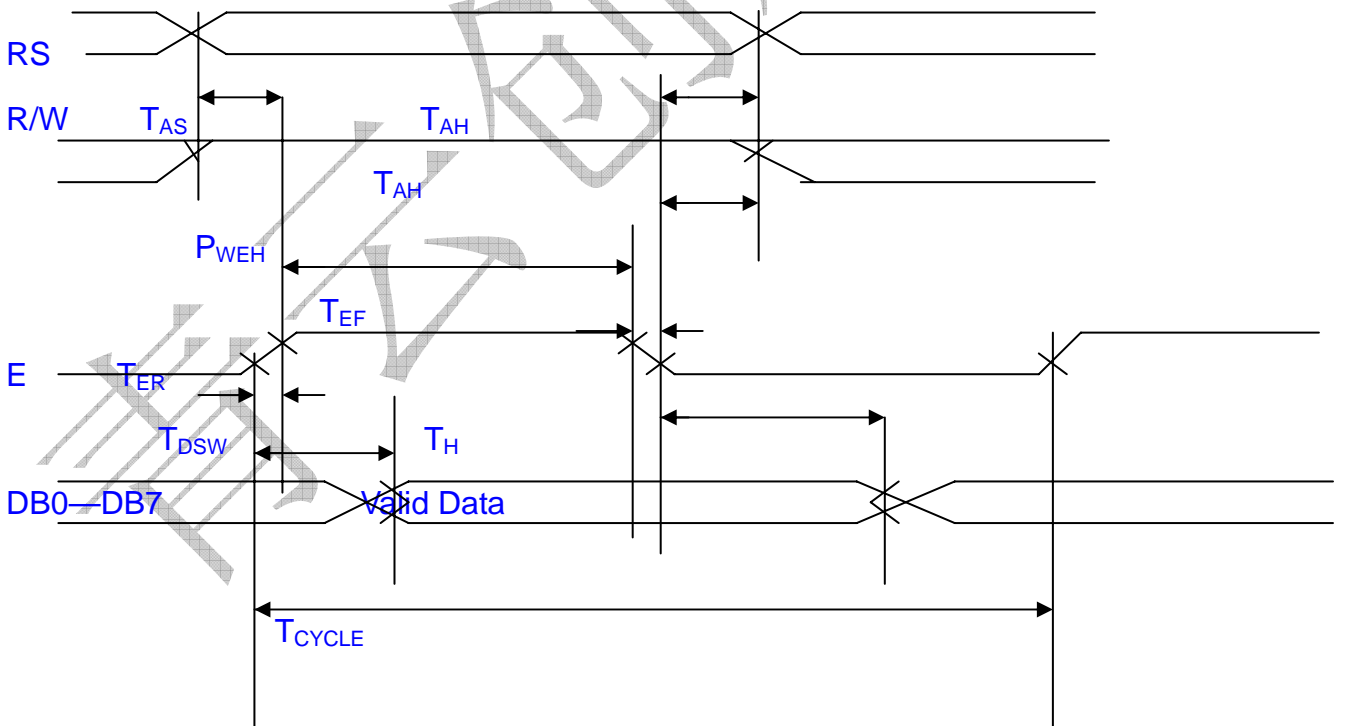

■ INSTRUCTION SETS

1. Instruction Table

Instruction	Instruction Code										Description	Execution time($f_{osc}=270kHz$)
	RS	RW	DB7	DB6	DB5	DB4	DB3	DB2	DB1	DB0		
Clear Display	0	0	0	0	0	0	0	0	0	1	Write "20H" to DDRM and set DDRAM address to "00H" from AC	1.52mS
Return Home	0	0	0	0	0	0	0	0	1	-	Set DDRAM address to "00H" from AC and return cursor to its original position if shifted. The contents of DDRAM are not changed.	1.52mS
Entry Mode Set	0	0	0	0	0	0	0	1	I/D	S	Assign cursor moving direction and enable the shift of entire display	38uS
Display ON/OFF Control	0	0	0	0	0	0	1	D	C	B	Set display(D), cursor (C), and blinking of cursor(B) on/off control bit.	38uS
Cursor or Display Shift	0	0	0	0	0	1	S/C	R/L	-	-	Set cursor moving and display shift control bit, and the direction, without changing of DDRAM data.	38uS
Function Set	0	0	0	0	1	DL	N	F	-	-	Set interface data length(DL:8-bit/4bit), numbers of display line (N:2-line/1line) and, display font type (F:5*10dots/5*8dot)	38uS
Set CGRAM Address	0	0	0	1	AC5	AC4	AC3	AC2	AC1	AC0	Set CGRAM address in address counter	38uS
Set DDRAM Address	0	0	1	AC6	AC5	AC4	AC3	AC2	AC1	AC0	Set DDRAM address in counter	38uS
Read Busy Flag and Address Counter	0	1	BF	AC6	AC5	AC4	AC3	AC2	AC1	AC0	Whether during internal operation or not can be known by reading BF. The contents of address counter can also be read.	
Write Data to RAM	1	0	D7	D6	D5	D4	D3	D2	D1	D0	Write data into internal RAM (DDRM/CGRAM).	38uS
Read Data from RAM	1	1	D7	D6	D5	D4	D3	D2	D1	D0	Read data from internal RAM (DDRAM/CGRAM).	38uS

8-bit Interface Mode (Condition: $f_{OSC} = 270 \text{ kHz}$)

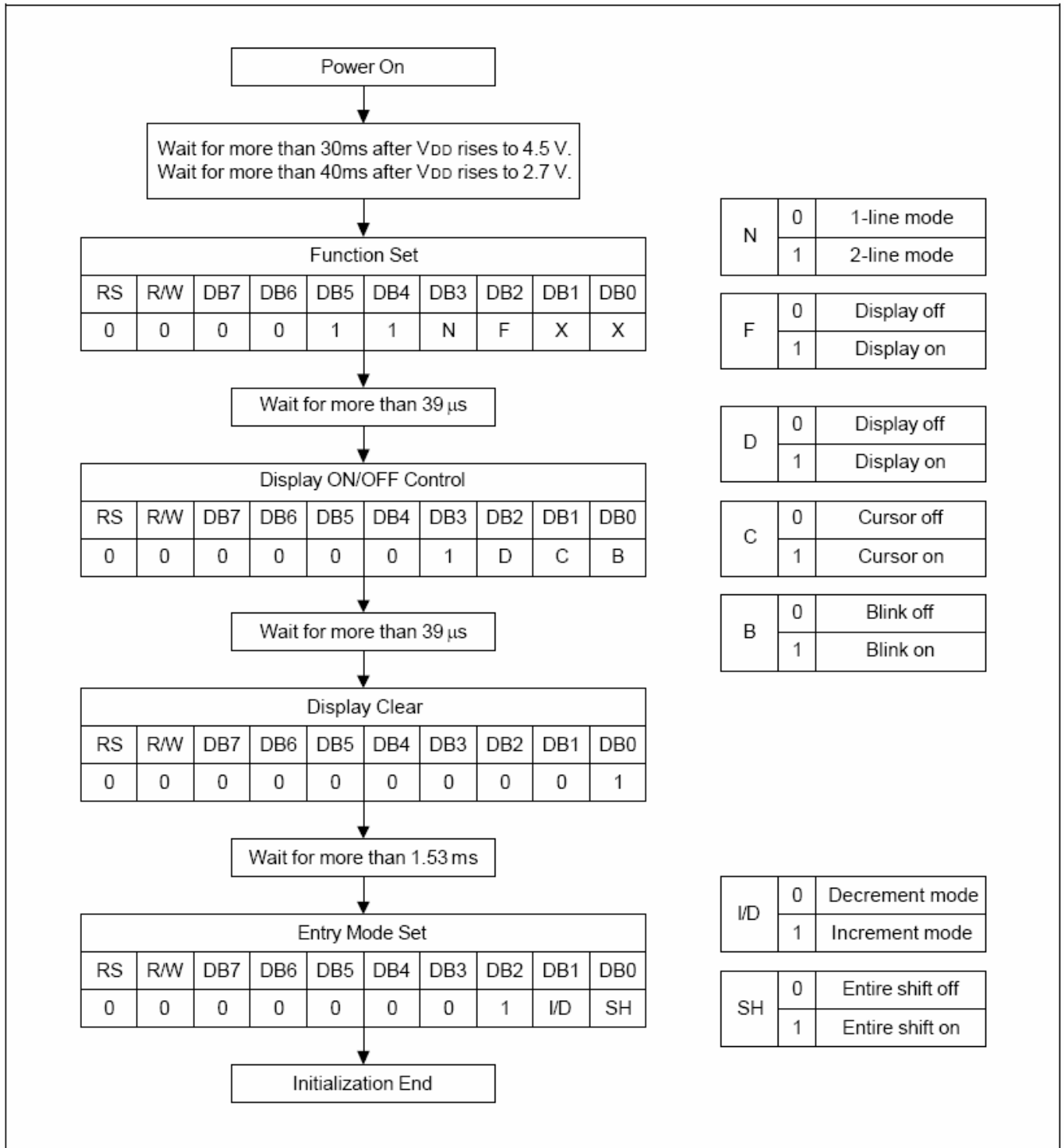

4-bit Interface Mode (Condition: $f_{OSC} = 270 \text{ kHz}$)

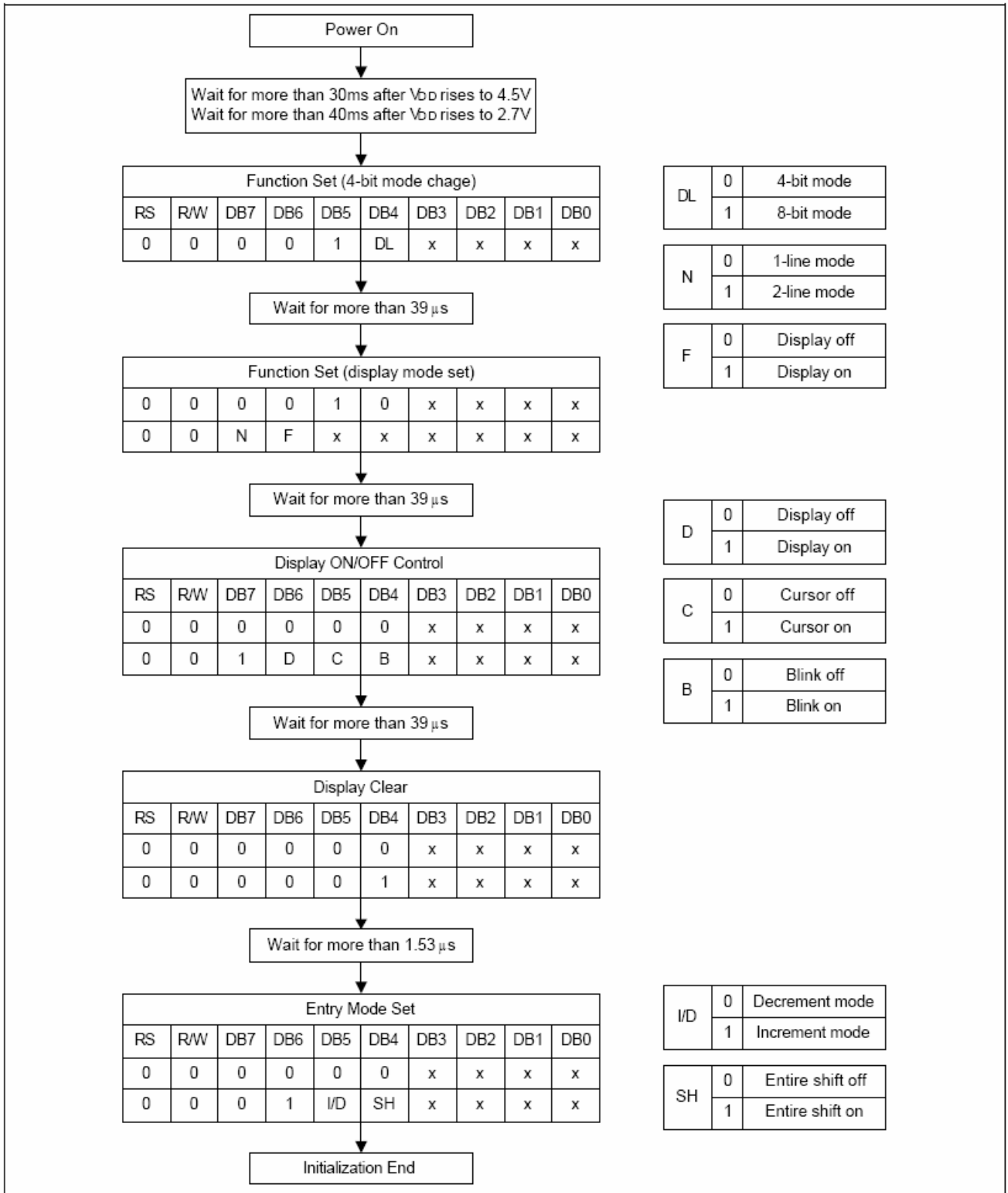

EXAMPLE OF PROGRAME:

COM EQU 20H ;指令寄存器
DAT EQU 21H; 数据寄存器
RS EQU P3.0;寄存器选择信号
RW EQU P3.4;读写选择信号
E EQU P3.6;使能信号
;初始化
NT1:

ORG 0000H
LJMP START

ORG 100H
START:

MOV COM,#38H;设置工作方式
LCALL PR1
MOV COM,#01H;清屏
LCALL PR1
MOV COM,#06H;设置输入方式
LCALL PR1
MOV COM,#0CH;设置显示方式
LCALL PR1

INT:

MOV R2,#50H ;显示80位
MOV COM,#80H ;设置DDRAM地址
LCALL PR1

AA: MOV DAT,0FFH;输入显示数据]

LCALL PR2
NOP
NOP
NOP
NOP
NOP
NOP
DJNZ R2,AA
LCALL DELAY
LCALL DELAY

MOV COM,#01H;清屏
LCALL PR1
MOV R2,#50H
MOV COM,#80H;设置DDRAM地址
LCALL PR1

BB: MOV DAT,#2AH;输入显示数据

```
LCALL PR2
NOP
NOP
NOP
NOP
NOP
NOP
NOP
DJNZ R2,BB
LCALL DELAY
LCALL DELAY
```

MOV COM,#01H;清屏

```
LCALL PR1
MOV R2,#50H
MOV COM,#80H;设置DDRAM地址
LCALL PR1
```

CC: MOV DAT,#58H;输入数据

```
LCALL PR2
NOP
NOP
NOP
NOP
NOP
NOP
DJNZ R2,CC
LCALL DELAY
LCALL DELAY
```

MOV COM,#01H;清屏

```
LCALL PR1
MOV COM,#80H;设置DDRAM地址
LCALL PR1
MOV DPTR,#TABCR
MOV R2,#80
MOV R3,#00H
```

CR_1: MOV A,R3

```
MOVC A,@A+DPTR
MOV DAT,A
LCALL PR2 ;写数据
INC R3
DJNZ R2,CR_1
LCALL DELAY ;演示用延时
```

LCALL DELAY ;演示用延时

```
MOV R4,#0FH
ROLL1:MOV COM,#18H ;画面向左滚动
```

```
LCALL PR1
LCALL DELAY
DJNZ R4,ROLL1
lcall delay
MOV COM,#01H;清屏
LCALL PR1
MOV COM,#84H;显示字符的地址
LCALL PR1
MOV DAT,#0ffH;显示字符代码
LCALL PR2
MOV DAT,#5FH;显示字符代码
LCALL PR2
```

```
MOV COM,#8eH;显示字符的首地址
LCALL PR1
MOV DAT,#0dbH
LCALL PR2
MOV DAT,#5FH
LCALL PR2
```

```
MOV COM,#0c4H
LCALL PR1
MOV DAT,#0ffH
LCALL PR2
MOV DAT,#5FH
LCALL PR2
MOV COM,#0ceH
LCALL PR1
MOV DAT,#0dbH
LCALL PR2
MOV DAT,#5FH
LCALL PR2
MOV R4,#08H
ROLL: MOV COM,#18H
LCALL PR1
LCALL DELAY
DJNZ R4,ROLL
lcall delay
JMP NT1
```

```
TABCR:DB 'BEIJING QINGYUN CHUANGXIN KEJI FAZHAN YOCHARACTER MATRIX LCD
MODULE IS PERFECT'
```

```
PR1:
PUSH ACC
CLR RS
SETB RW
PR11:
```

```
MOV P1,#0FFH ;P1置位, 准备读
SETB E
MOV A,P1 ;读BF和AC6-0值
CLR E
JB ACC.7,PR11 ;判别BF=1? 是转
CLR RW
MOV P1,COM ;写入指令代码
SETB E
NOP
NOP
NOP
CLR E
NOP
NOP
NOP
POP ACC
RET
```

PR2:

```
PUSH ACC
CLR RS
SETB RW
```

PR21:

```
MOV P1,#0FFH
SETB E
MOV A,P1 ;读BF和AC6-0值
CLR E
JB ACC.7,PR21
SETB RS
CLR RW
MOV P1,DAT
SETB E
NOP
NOP
NOP
CLR E
NOP
NOP
NOP
POP ACC
RET
```

delay: ;延时子程序

```
mov r1,#40
```

del0:

```
mov r2,#50
```

del1:

```
mov r3,#70
```

```
djnz r3,$
```

```
djnz r2,del1
```

```
djnz r1,del0  
ret ;延时子程序结束，返回到调用处的下一句  
end  
→
```

北京青云创新科技