



LITEMAX LD1041

Sunlight Readable 10.4" LCD Display

(1st Edition 3/26/2004)

All information is subject to change without notice.

LITEMAX Electronics Inc.

4F, No.131-3, Lane235, Bau-chiau Rd.,

Shin-dian City, Taipei County, Taiwan R.O.C.

Tel : 886-2-8919-1858

Fax: 886-2-8919-1300

Homepage: <http://www.litemax.com.tw>

Contents:

Introduction and overview..... P3

A. Physical specifications..... P4

B. Electrical specifications..... P5

 1. Pin assignment..... P5

 2. Absolute maximum ratings..... P6

 3. Electrical characteristics..... P7

 a. Typical operating conditions..... P7

 b. Display color v.s. input data signals..... P8

 c. Input signal timing..... P9

 d. Display position..... P10

 e. Backlight driving conditions..... P11

C. Optical specifications..... P12

D. Reliability test items..... P14

E. Display quality..... P15

F. Handling precaution P15

Appendix:

Fig.1 LCM outline dimensions..... P16

Fig.2 Timing chart..... P17

Li2701 Inverter P18

2020 A/D Board..... P24

INTRODUCTION AND OVERVIEW

This is a product specification that specifies form, fit, and function of the 10.4" TFT LCD monitor and its options. The LD1041 products are a family of high bright LCD monitors intended for use in a variety of industrial and commercial applications. Some of these applications include Car TV, Kiosk, Control Panel, Fish Finder, Marine, POI, Teketing, Aviation, Advertising, Gas Pumps, Signage... The LCD panel for LD1041 has a particularly fast response time of 35ms and consequently very well suited for video applications. The LD1041 is a 10.4" active matrix TFT LCD with a native resolution of 800X600 (SVGA). It has a typical luminance of 1500 nits with a +12VDC input. The video interface is through a standard 15 pin analog input with an integrated On-Screen Display (OSD).

OUTLINE

STRUCTURE AND PRINCIPLE

LD1041 module is composed of the driver LSIs for driving the TFT (Thin Film Transistor) array with an amorphous silicon thin film transistor liquid crystal display (a-Si TFT LCD) panel structure and a backlight. The a-Si TFT LCD panel structure is injected liquid crystal material into the narrow gap between a TFT array glass substrate and a color filter glass substrate.

RGB (Red, Green, and Blue) data signals from a source system are modulated into a form suitable for active matrix addressing by the onboard signal processor and sent to the driver LSIs which in turn address the individual TFT cells.

Working as an electro-optical switch, each TFT cell regulates transmitted light from the backlight assembly when worked by the data source. Color images are created by regulating the amount of transmitted light through the array of red, green and blue dots.

APPLICATIONS

Car TV, Kiosk, Control Panel, Fish Finder, Marine, POI, Teketing, Aviation, Advertising, Gas Pumps, Signage...

FEATURES

- www.DataSheet4U.com wide viewing angle
- . Fast response time
- . High Contrast Ratio
- . LVDS
- . Wide color gamut
- . Very hight brightness
- . Sunlight Readable

A. Physical specifications

NO.	Item	Specification	Remark
1	Display resolution (pixel)	800(H)×600(V)	
2	Active area (mm)	211.2(H)×158.4(V)	
3	Screen size (inch)	10.4(Diagonal)	
4	Pixel pitch (mm)	0.264(H)×0.264(V)	
5	Color configuration	R. G. B. Vertical stripe	
6	Overall dimension (mm)	340(W)×228(H)×54.2(D) (typ.)	Note 1
7	Weight (kg)	3.15 ±10	

Note 1: Refer to Fig. 1. & 2.

B. Electrical specifications

1. Pin assignment

(1) Input signal interface

	Symbol	Function	Etc.
1	V _{CC}	+3.3 V power supply	
2	V _{CC}	+3.3 V power supply	
3	GND	Ground	
4	GND	Ground	
5	RxIN0-	LVDS receiver signal channel 0	
6	RxIN0+		
7	GND	Ground	
8	RxIN1-	LVDS receiver signal channel 1	
9	RxIN1+		
10	GND	Ground	
11	RxIN2-	LVDS receiver signal channel 2	
12	RxIN2+		
13	GND	Ground	
14	CKIN-	LVDS receiver signal clock	
15	CKIN+		
16	GND	Ground	
17	NC	No Connection	
18	NC	No Connection	
19	GND	Ground	
20	GND	Ground	

CN1 (20P) connector: HRS DF 19K-20P-1H or compatible

(2) LVDS transmitter/receiver signal mapping

	Symbol	Function	
TxIN0	R0	Red data (LSB)	6 bit red display data
TxIN1	R1	Red data	
TxIN2	R2	Red data	
TxIN3	R3	Red data	
TxIN4	R4	Red data	
TxIN5	R5	Red data (MSB)	
TxIN6	G0	Green data (LSB)	6 bit green display data
TxIN7	G1	Green data	
TxIN8	G2	Green data	
TxIN9	G3	Green data	
TxIN10	G4	Green data	
TxIN11	G5	Green data (MSB)	
TxIN12	B0	Blue data (LSB)	6 bits blue display data
TxIN13	B1	Blue data	
TxIN14	B2	Blue data	
TxIN15	B3	Blue data	
TxIN16	B4	Blue data	
TxIN17	B5	Blue data (MSB)	
TxIN18	Hs	Horizontal sync.	
TxIN19	Vs	Vertical sync.	
TxIN20	DE	Data enable	
TxCLKIN	CLK	Clock	Dot clock

www.DataSheet4U.com
2. Absolute maximum ratings
(GND = 0 V)

Parameter	Symbol	Values		Unit	Remark
		Min.	Max.		
Power voltage	V_{CC}	-0.3	4	V_{DC}	At 25°C
Input signal voltage	V_{LH}	-0.3	$V_{CC}+0.3$	V_{DC}	At 25°C
Operating temperature	T_{OP}	0	+50	°C	Note 1
Storage temperature	T_{ST}	-20	+60	°C	Note 1

Note 1: The relative humidity must not exceed 90% non-condensing at temperatures of 40°C or less. At temperatures greater than 40°C, the wet bulb temperature must not exceed 39°C. When operate at low temperatures, the brightness of CCFL will drop and the lifetime of CCFL will be reduced.

Note 2: The unit should not be exposed to corrosive chemicals.

3. Electrical characteristics

a. Typical operating conditions

	Item	Symbol	Min.	Typ.	Max.	Unit	Remark
Power supply voltage	Input voltage	V_{CC}	3.0	3.3	3.6	V	
	Current consumption	I_A	243.7	242	245.2	mArms	Note 1
		I_B	255.4	252.1	253.5	mArms	
	Inrush current	I_{RUSH}	-	-	1500	mApeak	Note 2
Internal logic	Low voltage	V_{IL}	0	-	$0.3 V_{CC}$		
	High voltage	V_{IH}	$0.7 V_{CC}$	-	V_{CC}		
	Power ripple voltage	V_{RP}	-	-	100	mVp-p	

Note 1: Effective value (mArms) at $V_{CC} = 3.3 V/25^{\circ}C$.

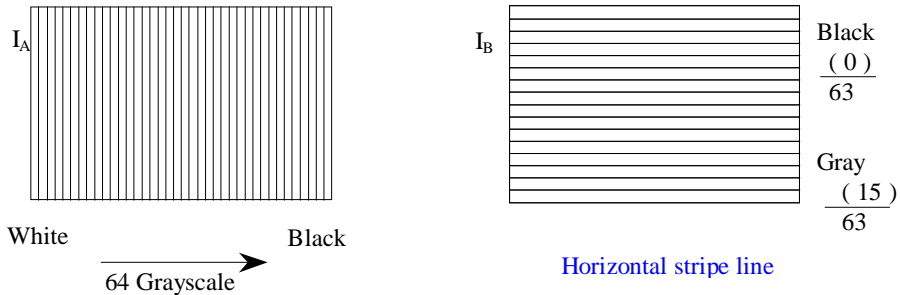

Note 2: Refer to the following power-on condition.

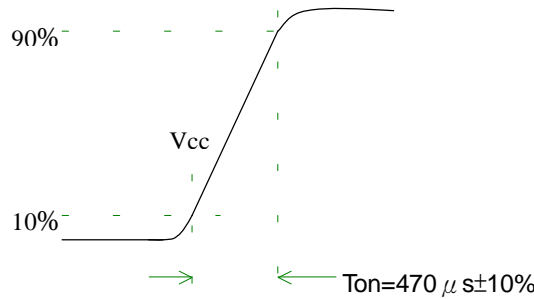

www.DataSheet4U.com

Sequence of Power-on/off and signal-on/off

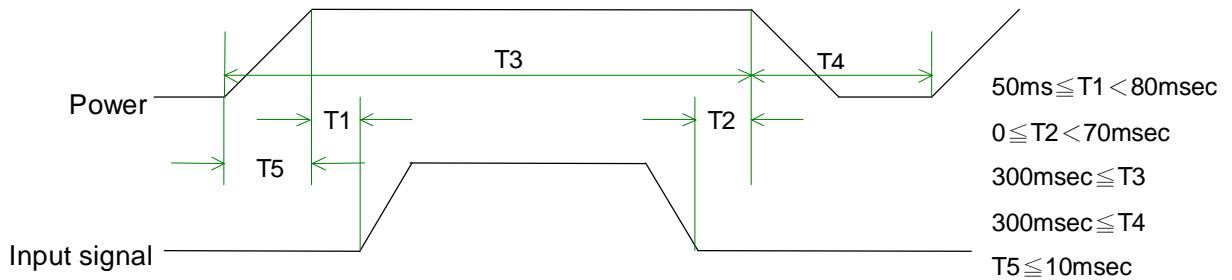

Apply the lamp voltage within the LCD operating range. When the backlight turns on before the LCD operation or the LCD turns off before the backlight turns off, the display may momentarily become abnormal.

Caution

The above on/off sequence should be applied to avoid abnormal function in the display.
 In case of handling:
 Make sure to turn off the power when you plug the cable into the input connector or pull the cable out of the connector.

b. Display color v.s. input data signals

Display colors		Data signal (0: Low level, 1: High level)																	
		R5	R4	R3	R2	R1	R0	G5	G4	G3	G2	G1	G0	B5	B4	B3	B2	B1	B0
Basic colors	Black	0	0	0	0	0	0	0	0	0	0	0	0	0	0	0	0	0	0
	Blue	0	0	0	0	0	0	0	0	0	0	0	0	1	1	1	1	1	1
	Red	1	1	1	1	1	1	0	0	0	0	0	0	0	0	0	0	0	0
	Magenta	1	1	1	1	1	1	0	0	0	0	0	0	1	1	1	1	1	1
	Green	0	0	0	0	0	0	1	1	1	1	1	1	0	0	0	0	0	0
	Cyan	0	0	0	0	0	0	1	1	1	1	1	1	1	1	1	1	1	1
	Yellow	1	1	1	1	1	1	1	1	1	1	1	1	0	0	0	0	0	0
	White	1	1	1	1	1	1	1	1	1	1	1	1	1	1	1	1	1	1
Red grayscale	Black	0	0	0	0	0	0	0	0	0	0	0	0	0	0	0	0	0	0
	Dark	0	0	0	0	0	1	0	0	0	0	0	0	0	0	0	0	0	0
	↑																		
	↓																		
	bright	1	1	1	1	0	1	0	0	0	0	0	0	0	0	0	0	0	0
	Red	1	1	1	1	1	0	0	0	0	0	0	0	0	0	0	0	0	0
Green grayscale	Black	0	0	0	0	0	0	0	0	0	0	0	0	0	0	0	0	0	0
	Dark	0	0	0	0	0	0	0	0	0	1	0	0	0	0	0	0	0	0
	↑																		
	↓																		
	bright	0	0	0	0	0	0	1	1	1	1	0	1	0	0	0	0	0	0
	Green	0	0	0	0	0	0	1	1	1	1	1	1	0	0	0	0	0	0
Blue grayscale	Black	0	0	0	0	0	0	0	0	0	0	0	0	0	0	0	0	0	0
	Dark	0	0	0	0	0	0	0	0	0	0	0	0	0	0	0	0	1	0
	↑																		
	↓																		
	bright	0	0	0	0	0	0	0	0	0	0	0	0	1	1	1	1	0	1
	Blue	0	0	0	0	0	0	0	0	0	0	0	0	1	1	1	1	1	0

Note: Each basic color can be displayed in 64 gray scales using the 6 bit data signals. By combining the 18-bit data signals(R, G, B), the 262,144 colors can be achieved on the display.

c. Input signal timing

Timing diagrams of input signal are shown in Fig 2.

(1) Timing characteristics of input signals

(a) DE mode

Item	Symbol	Min.	Typ.	Max.	Unit	Remark
Clock frequency	Fck	38	40	48	MHz	
Horizontal blanking	Thb1	50	256	500	Clk	
Vertical blanking	Tvb1	10	28	150	Th	

(b) HV mode

Item	Symbol	Min.	Typ.	Max.	Unit	Remark
Clock frequency	Fck	38	40	48	MHz	
Hsync period	Th	850	1056	1300	Clk	
Hsync pulse width	Thw	10	128	-	Clk	
Hsync front porch	Thf	15	40	-	Clk	
Hsync back porch	Thb	10	88	-	Clk	
Hsync blanking	Thb1	50	256	500	Clk	
Vsync period	Tv	610	628	750	Th	
Vsync pulse width	Tvw	1	4	-	Th	
Vsync front porch	Tvf	0	1	-	Th	
Vsync blanking	Tvb1	10	28	150	Th	
Hsync/Vsync phase shift	Tvpd	2	320	-	Clk	

Item	Symbol	Value	Unit	Description
Horizontal display start	The	218	Clk	After falling edge of Hsync, counting 218clk, then getting valid data from 219th clk's data.
Vertical display start	Tve	25	Th	After falling edge of Vsync, counting 25th, then getting 26th Th's data.

(2) The timing condition of LVDS

Item	Symbol	Min.	Typ.	Max.	Unit
The differential level	VID	0.1	-	0.6	V
The common mode input voltage	VIC	$\frac{ VID }{2}$	-	$2.4 - \frac{ VID }{2}$	V
The input setup time	tsu1	500	-	-	ps
The input hold time	th1	500	-	-	ps

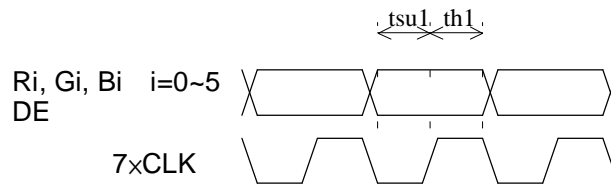
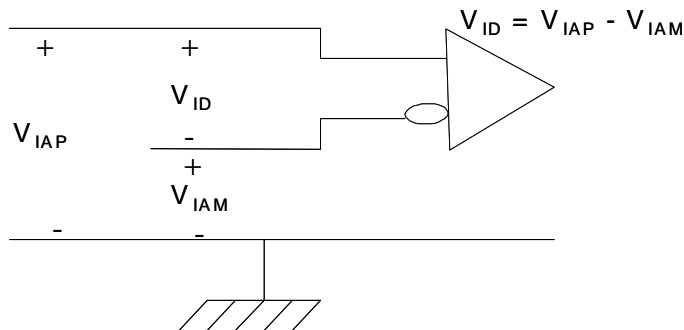

d. Display position

D(1,1)	D(2,1)	D(X,1)	D(799,1)	D(800,1)
D(1,2)	D(2,2)	D(X,2)	D(799,2)	D(800,2)
⋮		⋮	⋮	⋮
D(1,Y)	D(2,Y)	D(X,Y)	D(799,Y)	D(800,Y)
⋮		⋮	⋮	⋮
D(1,599)	D(2,599)	D(X,599)	D(799,599)	D(800,599)
D(1,600)	D(2,600)	D(X,600)	D(799,600)	D(800,600)

e. Backlight driving conditions

Parameter	Symbol	Min.	Typ.	Max.	Unit	Remark
Lamp voltage	V_L	-	420	-	Vrms	Note 1
Lamp current	I_L	33	36	39	mArms	Note 1
Power consumption	P_L	-	30.0	-	W	Note 2
Lamp starting voltage	V_S	-	-	-	Vrms	T=0°C
		-	1700	-		T=25°C
Frequency	F_L	50	55	60	KHz	Note 3
Lamp life time	L_L	-	50,000	-	Hr	Note 1, 4

Note 1: T= 25°C, I_L = 6mA/Lamp (Total 6 lamps)

Note 2: Inverter should be designed with the characteristic of lamp. When you are designing the inverter, the output voltage of the inverter should comply with the following conditions.

- (1) The area under the positive and negative cycles of the waveform of the lamp current and lamp voltage should be area symmetric (the symmetric ratio should be larger than 90%).
- (2) There should not be any spikes in the waveform.
- (3) The waveform should be sine wave as possible.
- (4) Lamp current should not exceed the maximum value within the operating Temperature (It is prohibited to over the maximum lamp current even if operated in The non-guaranteed temperature). When lamp current over the maximum value for a long time, it may cause fire. Therefore, it is recommend that the inverter should have the current limited circuit.

Note 3: Lamp frequency may produce interference with horizontal synchronous frequency and this may cause line flow on the display. Therefore lamp frequency shall be detached from the horizontal synchronous frequency and its harmonics as far as possible in order to avoid interference.

www.DataSheet4U.com

Note 4: Brightness ($I_L=6mA/Lamp$) to be decrease to the 50% of the initial value.

Note 5:

CN2~4 connector (backlight): JST BHR-03VS-1

Pin no.	Symbol	Function	Remark
1	H	CCFL power supply (H.V.)	Cable color: Pink
2	H	CCFL power supply (H.V.)	Cable color: Pink

Mating connector: JST SM03(4.0)B-BHS-1-TB

CN5 connector (backlight): JST BHSR-02VS-1

Pin no.	Symbol	Function	Remark
1	L	CCFL power supply (GND)	Cable color: White
2	L	CCFL power supply (GND)	Cable color: Pink

Mating connector: JST SM02B-BHSS-1-TB

C. Optical specifications (Note 1, Note 2)

Item	Symbol	Condition	Specification			Unit	Remark
			Min.	Typ.	Max.		
Response time Rising time Falling time	Tr Tf	$\theta = 0^\circ$	- -	10 25	20 30	ms	Note 4
Contrast ratio	CR	$\theta = 0^\circ$	400	500	-		Note 3,5
Viewing angle Top Bottom Left Right		$CR \geq 10$	- - - -	40 60 60 60	- - - -	deg.	Note 3,6
Brightness	Y_L	$\theta = 0^\circ$	1200	1500	-	nit	Note 3,7,8,9
Color chromaticity(CIE)	W_x	$\theta = 0^\circ$	0.290	0.320	0.350		Note 3,8,9
	W_y		0.300	0.330	0.360		
	R_x		TBD	TBD	TBD		
	R_y		TBD	TBD	TBD		
	G_x		TBD	TBD	TBD		
	G_y		TBD	TBD	TBD		
	B_x		TBD	TBD	TBD		
	B_y		TBD	TBD	TBD		
White uniformity	δ_w		-	-	1.3		Note 3,9,10

Note 1: Ambient temperature = 25°C.

Note 2: To be measured in dark room after backlight warm up 30 minutes.

Note 3: To be measured with a viewing cone of 1° by Topcon luminance meter BM-5A.

Note 4: Definition of response time:

www.DataSheet4U.com

The output signals of BM-7 are measured when the input signals are changed from “Black” to “White” (falling time) and from “White” to “Black” (rising time), respectively. The response time means the interval between the 10% and 90% of amplitudes. Refer to figure as below.

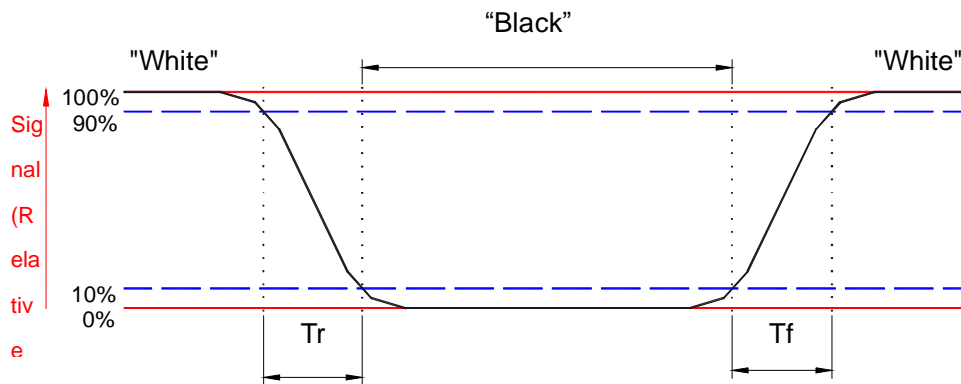

Note 5. Definition of contrast ratio:

Contrast ratio is calculated with the following formula.

$$\text{Contrast ratio (CR)} = \frac{\text{Luminance on the white raster}}{\text{Luminance on the black raster}}$$

Note 6: Definition of viewing angle:

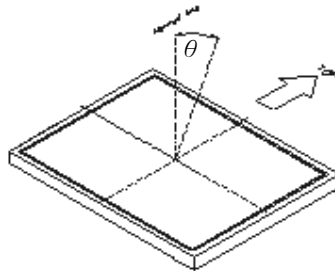

Note 7: Definition of the 5 points (from A to E) on panel, refer to figure as below

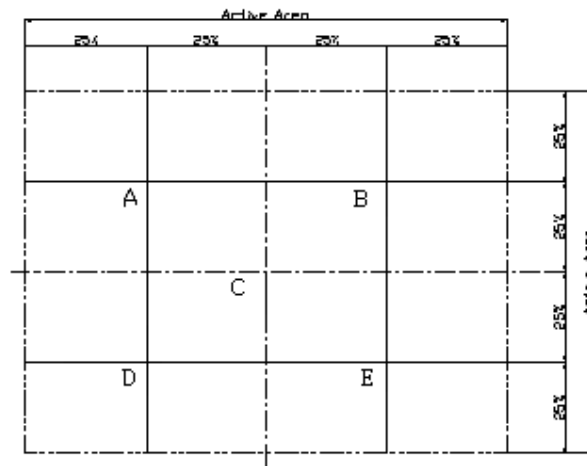

www.DataSheet4U.com

Note 8: Definition of brightness: To measure at center point of the screen (C)
(After light up 20 minutes)

Note 9: Driving conditions for CCFL: $I_L=6$ mA, 55KHz Frequency

Note 10: Definition of white uniformity:

$$\delta w = \frac{\text{Maximum Luminance of five points (brightness)}}{\text{Minimum Luminance of five points (brightness)}}$$

D. Reliability test items (Tentative)

Test tem	Test Condition	Remark
High temperature storage	60°C, 240Hrs	Note 1, 2, 3
Low temperature storage	-20°C, 240Hrs	Note 1, 2, 3
High temperature & high humidity operation	40°C, 90%RH, 240Hrs (No condensation)	Note 1, 2, 3
High temperature operation	50°C, 240Hrs	Note 1, 2, 3
Low temperature operation	0°C, 240Hrs	Note 1, 2, 3
Electrostatic discharge (non-operation)	150 pF, 150 Ω, 10kV, 1 second, 9 position on the panel, 10 times each place	Note 3
Vibration (non-operation)	1.5G, 10Hz ~ 200Hz ~ 10Hz 30 minutes for each Axis (X, Y, Z)	Note 1, 2, 3
Mechanical shock (non-operation)	50G/20ms, ±X, ±Y, ±Z half-Sin, one time	Note 1, 2, 3
Thermal shock (non-operation)	1. -20°C ± 3°C ... 30 minutes 60°C ± 3°C ... 30 minutes 2. 100 cycles 3. Temperature transition time within 5 minutes	Note 1, 2, 3

Note 1: Evaluation should be tested after storage at room temperature for one hour.

Note 2: There should be no change which might affect the practical display function when the display quality test is conducted under normal operating condition.

Note 3: Judgement: 1. Function OK

2. No serious image quality degradation

E. Display quality

The display quality of the color TFT-LCD module should be in compliance with the Litemax's OQC inspection standard.

F. Handling precaution

The Handling of the TFT-LCD should be in compliance with the Litemax's handling principle standard.

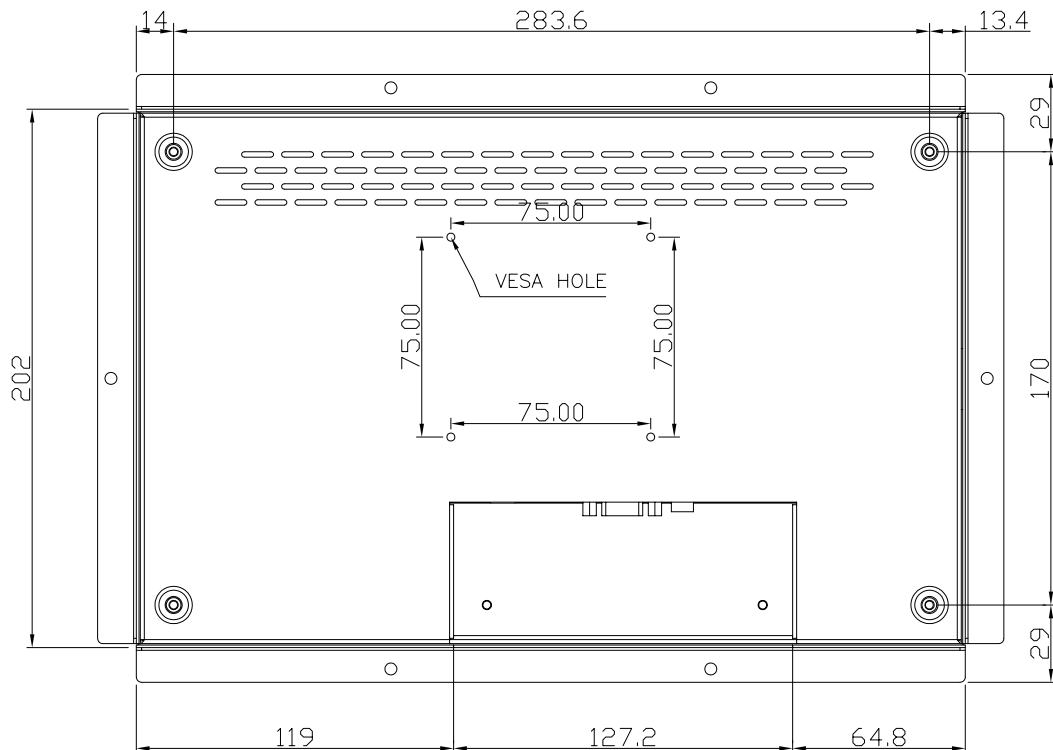
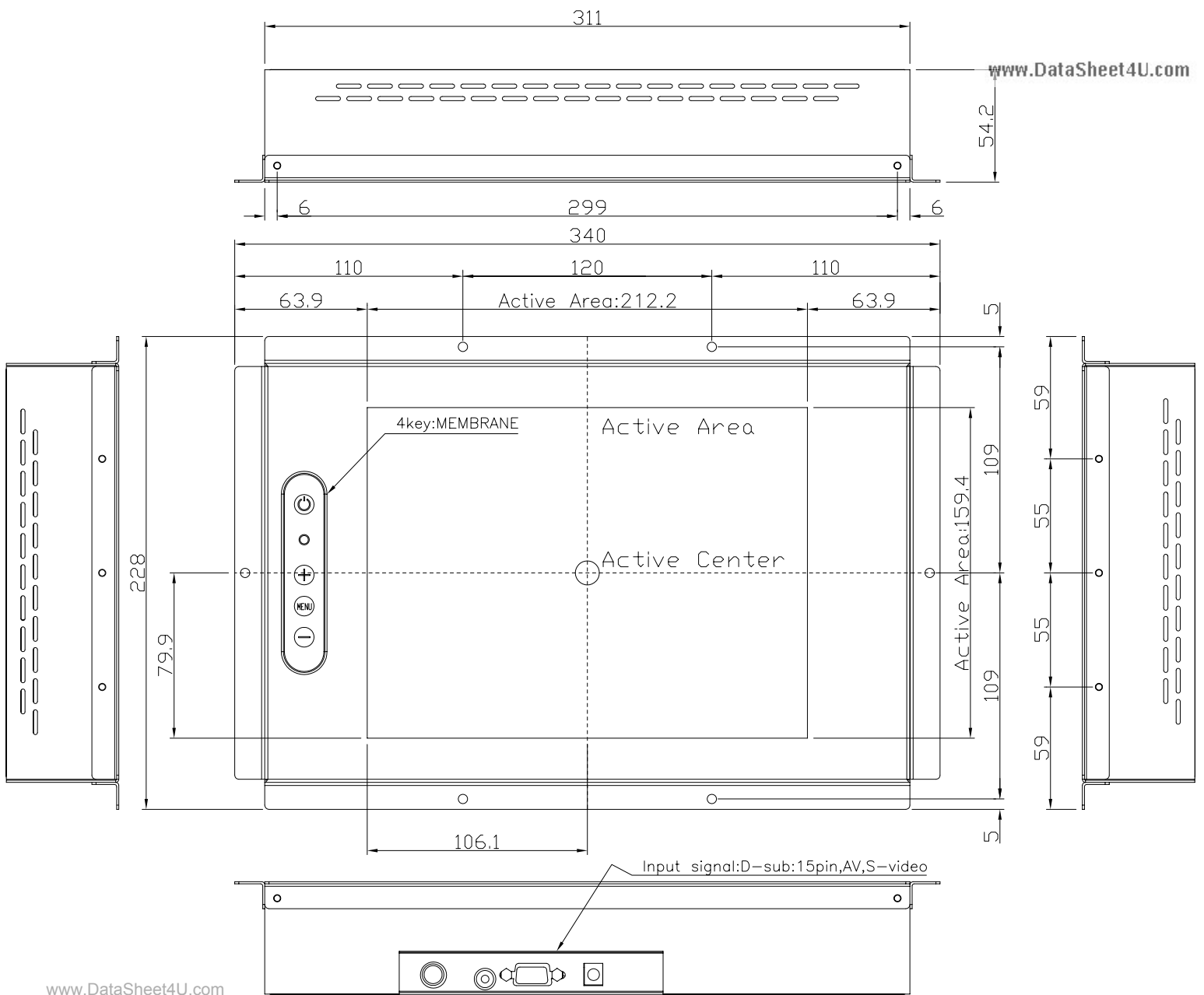

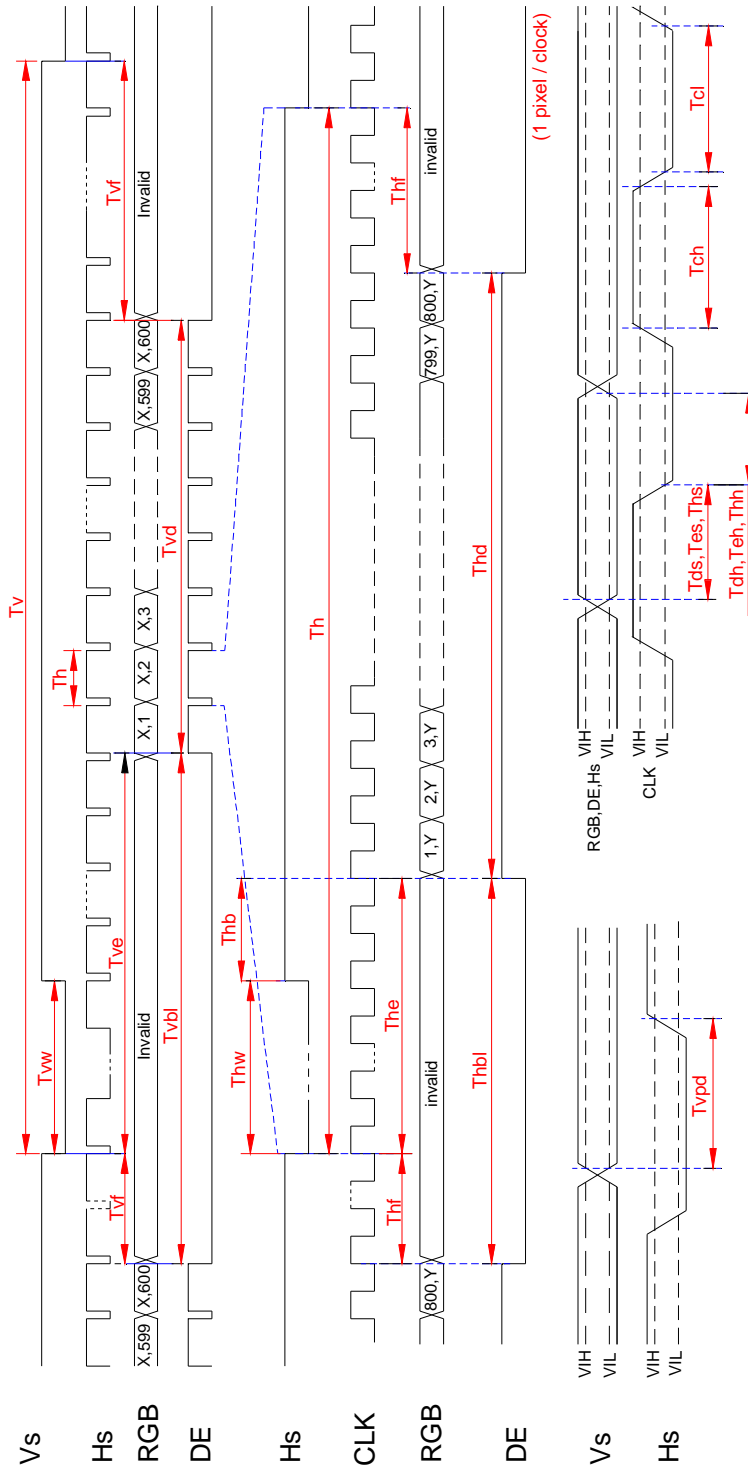

Fig.2 Timing chart



1. ENVIRONMENT CHARACTERISTICS:

- 1-1. All Conditions are at 25 Ambient unless otherwise specified
- 1-2. Operating Temperature 0 ~~~~+55
- 1-3. Storage Temperature -25 ~~~~~+70
- 1-4. Humidity Operating 95 %
- 1-5. Humidity Storage 95 %

2. CONNECTOR PIN ASSIGNMENT:

Input : CN4

Model : 2001J-06-RT(90 °)

Supplier : ORICH

Pin	Symbol
1	Vin
2	Vin
3	ON/OFF
4	Brt ADJ(0.0V~5.0V)
5	GND
6	GND

Output : CN1,CN2,CN3

Model : SM02(8.0)B-BHS-1-TB

Supplier : JST

Pin	Symbol
1	HV
2	HV

Output : CN5

Model : SM02B-BHSS-1-TB

Supplier : JST

1	RETURN
2	RETURN

www.DataSheet4U.com

TEST INSTRUMENT:

1. OSCILLOSCOPE : TDS380 DIGITAL REAL-TIME OSCILLOSCOPE
2. HIGH VOLTAGE PROBE : TEKTRONIX P5100 (1:100)
3. CURRENT PROBE AMPLIFIER : TEKTRONIX AM503B
4. CURRENT PROBE : TEKTRONIX A6302
5. DC POWER SUPPLY : GW GPC-3060D
6. MULTIMETER : FLUKE 45 DUAL DISPLAY



3. SCOPE

3-1 This document defines the requirements for the CCFL inverter of the TFT-LCD panel.
This product is compatible with **10" Six Lamp Panel**.

4. ELECTRICAL CHARACTERISTICS

4-1 INPUT Brt. ADJ=0.0V.

PARAMETER	SYMBOL	MIN.	NOM.	MAX.	UNIT	REMARK
INPUT VOLTAGE	V _{in}	10.8	12.0	13.2	V	
INPUT CURRENT	I _{in}	1450	1770	2010	mA	RL=70K *6 V_{in} = 12V
LAMP FREQUENCY	FL(1,2,3)	46	51	56	KHz	V_{rmt}=0.0V
	FL(4,5,6)	46	51	56		
OUTPUT CURRENT	I _{out} (1,2,3)	6.0	6.5	7.0	mA	V_{rmt}=0.0V
	I _{out} (4,5,6)	6.0	6.5	7.0		
OPEN OUTPUT VOLTAGE	V _s (1,2,3)	----	1500	----	V _{rms}	V_{in}=12V
	V _s (4,5,6)	----	1500	----		
LAMP VOLTAGE	V _{out} 1,2,3	----	460	----	V _{rms}	V_{rmt}=0.0V
	V _{out} 4,5,6	----	460	----		

4-2 INPUT Brt. ADJ=5.0V.

PARAMETER	SYMBOL	MIN.	NOM.	MAX.	UNIT	REMARK
INPUT VOLTAGE	V _{in}	10.8	12.0	13.2	V	
INPUT CURRENT	I _{in}	640	830	1050	mA	RL=70K *6 V_{in} = 12V
LAMP FREQUENCY	FL(1,2,3)	46	51	56	KHz	V_{rmt}=5.0V
	FL(4,5,6)	46	51	56		
OUTPUT CURRENT	I _{out} (1,2,3)	4.0	4.5	5.0	mA	V_{rmt}=5.0V
	I _{out} (4,5,6)	4.0	4.5	5.0		
LAMP VOLTAGE	V _{out} 1,2,3	----	310	----	V _{rms}	V_{rmt}=5.0V
	V _{out} 4,5,6	----	310	----		

NOTE: All Conditions are at 25 Ambient unless otherwise specified

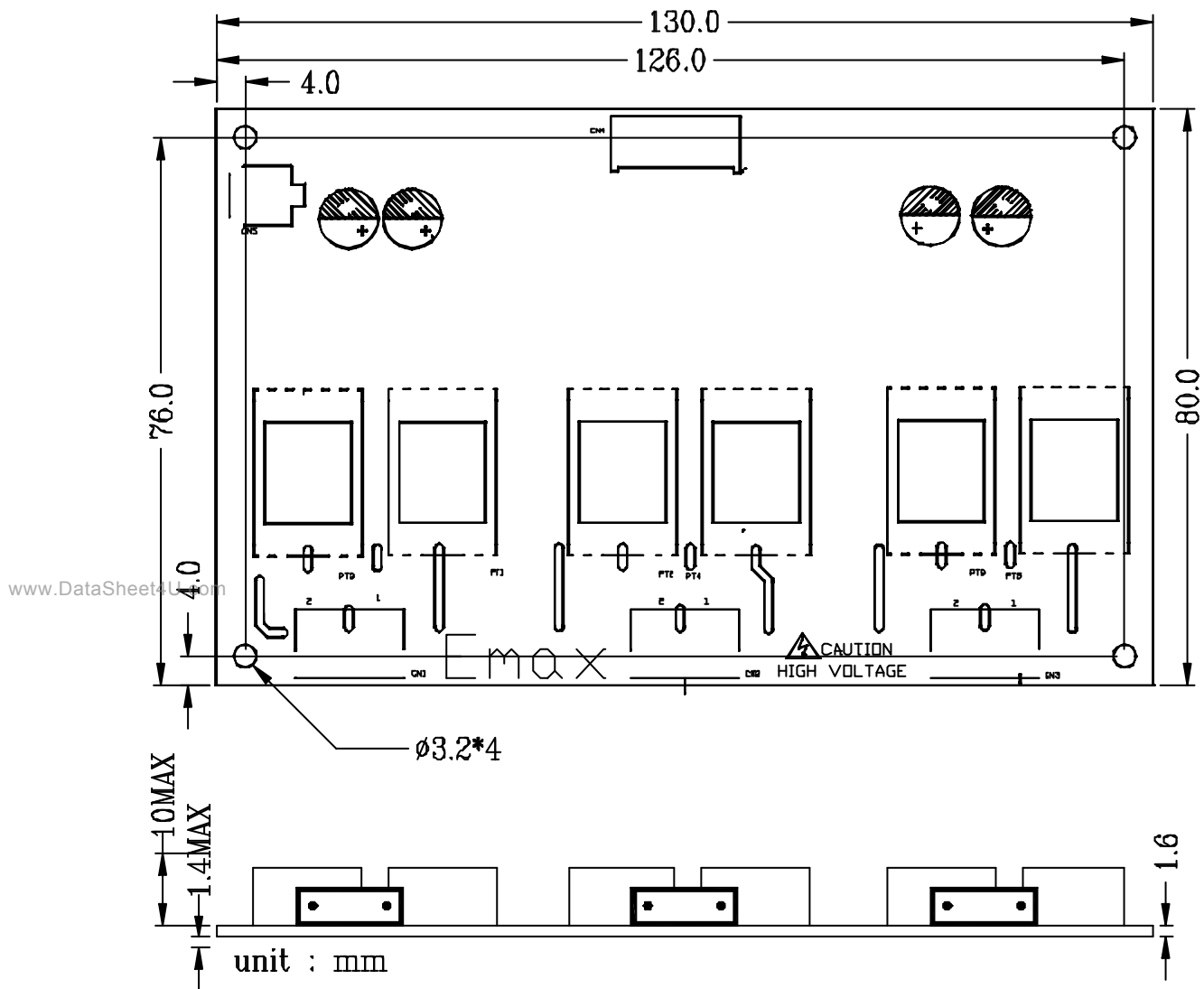

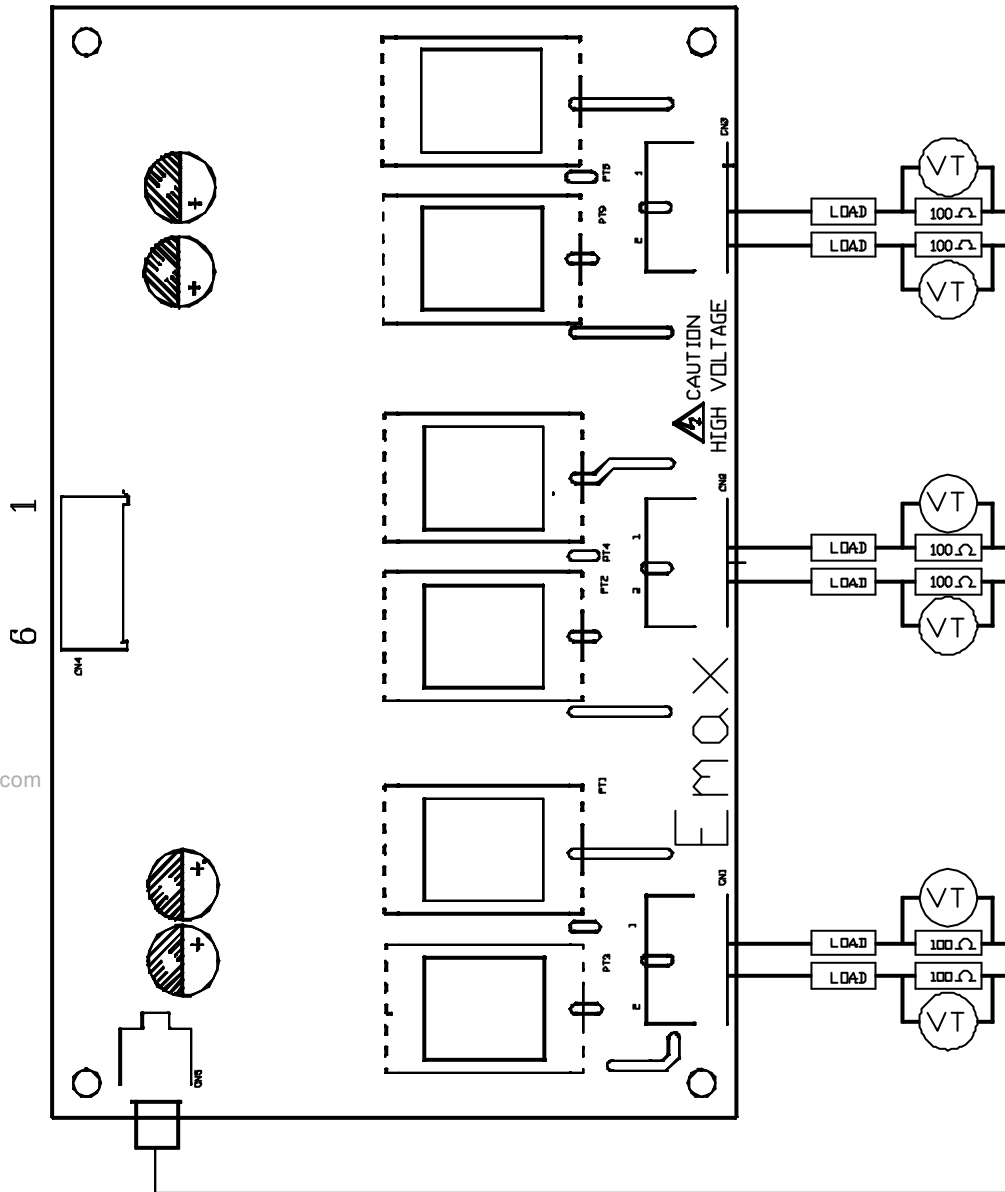

www.DataSheet4U.com

STANDARD 2020 A/D BOARD SPECIFICATION

General Descriptions

The Realtek RTD2020 is a highly-integrated single chip IC controller solution for producing real time, top quality digital video and computer graphic images on LCD monitor/flat panel displays, such as XGA LCD monitors. LCD monitors and flat panel displays provide a sharp, flicker free display while saving space and energy for desktop PC applications. The RTD2020 provides an ideal interface between industry standard digital graphics controllers and a wide variety of LCD panel devices. Flat panel devices using the RTD2020 can support all incoming VESA modes and interface to any TFT LCD device, up to SXGA (1280x1024) resolution

Features

- Supports 24-bit pixel digital input up to 160Mhz
- Built-in YUV to RGB color space converter & de-interlace
- Compatibility with standard VESA mode and VGA,SVGA,XGA,SXGA TFT LCD panel
- Smart engine for Phase and Image position calibration
- Independent horizontal/vertical scaling and support VESA standard Timing
- Embedded OSD of 12*18 dot font per character
- 4 channel 8-bits PWM output for high quality voice
- Auto detection VGA separate and composite synchronizes signal
- Support VGA analog 15-pin D-Sub standard input and option AV/S video input and TV decoder

STANDARD 2020 A/D BOARD SPECIFICATION

Block Diagram

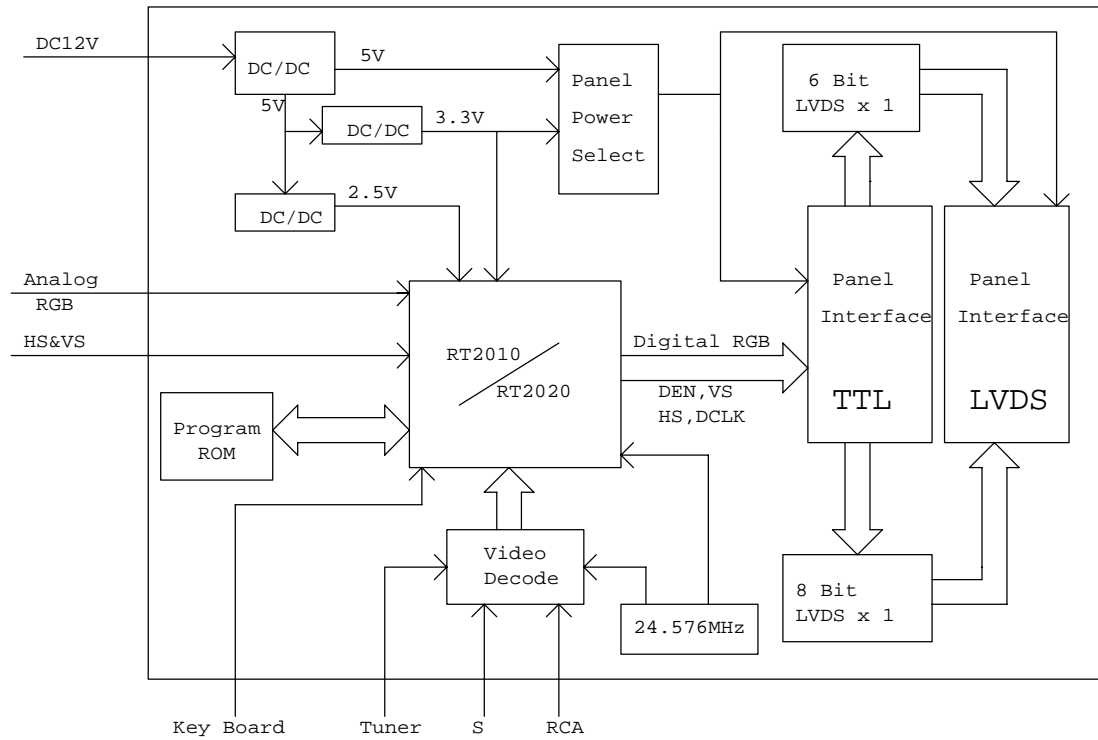

STANDARD 2020 A/D BOARD SPECIFICATION

Connector Description

Connector Indicate List

Indicate	Function	Note
JR1	S-VIDEO INPUT	MINI DIN 6PIN (OPTION)
J24	RCA-VIDEO INPUT	RCA JACKET (OPTION)
CN1	VGA INPUT	D-SUB 15PIN FEMALE
CN2	POWER CONNECTOR	φ 2.5
CN3	AUDIO IN CONNECTOR	φ 3.0
J22,23	SPEAKER CONNECTOR	PH:2.0mm,2PIN,180
J2	INVERTER CONNECTOR	PH:2.0mm,4PIN,90 °
J1	KEY BOARD CONNECTOR	PH:2.0mm,10PIN,90 °
J26	LCD FOR LVDS(PIN HEAD)	PH:2.0mm,2*15PIN,180°
JV3	TV BOARD CONNECTOR	PH:2.0mm,8PIN,180°, (OPTION)
J5,J6	TTL OUTPUT FPC CONNECTOR	PH:0.5mm,45/30PIN,90°(OPTION)

J22,J23:Speaker Connector

PIN	Function	Note
1	SIGNAL	
2	GND	

J2:Inverter Connector

PIN	Function	Note
1	12V VCC	
2	GND	
3	BACKLIGHT POWER ON/OFF	
4	BRIGHTNESS CONTROL	

J1:Key Board Connector

PIN	Function	Note
1	5V DVCC	
2	IR INPUT	
3	MENU(AUTO) KEY	
4	ENTER KEY	
5	SEL(RIGHT) KEY	
6	SEL(LEFT) KEY	
7	ACTIVE (GREEN) LED	
8	STANDBY(RED) LED	
9	POWER KEY	
10	GND	

STANDARD 2020 A/D BOARD SPECIFICATION

J26:LCD For LVDS Connector

PIN	Function	Note
1	PANEL VCC	
2	PANEL VCC	
3	PANEL VCC	
4	DGND	
5	DGND	
6	DGND	
7	DGND	
8	DGND	
9	DGND	
10	RXOIN3+	
11	RXOIN-	
12	RXOCKIN+	
13	RXOCKIN-	
14	RXOIN2+	
15	RXOIN2-	
16	RXOIN1+	
17	RXOIN1-	
18	RXOIN0+	
19	RXOIN0-	
20	RXEIN3+	
21	RXEIN3-	
22	RXECKIN+	
23	RXECKIN-	
24	RXEIN2+	
25	RXEIN2-	
26	RXEIN1+	
27	RXEIN1-	
28	RXEIN0+	
29	RXEIN0-	
30	DGND	

STANDARD 2020 A/D BOARD SPECIFICATION

JV3:TV Board Connector

PIN	Function	Note
1	5V DVCC	
2	12V VCC	
3	11CSCL	
4	11CSDA	
5	IF VIDEO	
6	GND	
7	IF AUDIO	
8	IF AUDIO1	

JR1,J24:RCA/S-Video Input

PIN	Function	Note
1	YIN	JR1
2	CIN	JR1
3	VGND	JR1
4	VIN	J24
5	GND	J24

CN1:VGA Input

PIN	Function	Note
1	R	
2	G	
3	B	
4	NC	
5	DGND	
6	RAGND	
7	GAGND	
8	BAGND	
9	NC	
10	DGND	
11	NC	
12	DDCSDA	
13	HSIN	
14	VSIN	
15	DDCSCL	

STANDARD 2020 A/D BOARD SPECIFICATION

CN2:Power Connector

PIN	Function	Note
1	12V GND	JR1
2	12V GND	JR1
3	12VCC	

CN3:Audio In Connector

PIN	Function	Note
1	IF_AUDIO,INR	SPEAKER,TDA7496L
2	GND	
3	GND	
4	IF_AUDIO,INL	SPEAKER,TDA7496L
5	GND	

J5:TTL Output FPC Connector

PIN	Function	Note
1	NO FUNCTION	
2	NO FUNCTION	
3	NC FUNCTION	
4	PANEL VCC	
5	PANEL VCC	
6	DARED0	
7	DARED1	
8	DARED2	
9	DARED3	
10	GND	
11	DARED4	
12	DARED5	
13	DARED6	
14	DARED7	
15	GND	
16	DAGRNO	
17	DAGRNO	
18	DAGRNO	
19	DAGRNO	
20	GND	
21	DAGRNO	
22	DAGRNO	
23	DAGRNO	
24	DAGRNO	
25	GND	

26	DABLU0	
27	DABLU1	
28	DABLU2	
29	DABLU3	
30	GND	
31	DABLU4	
32	DABLU5	
33	DABLU6	
34	DABLU7	
35	GND	
36	NO FUNCTION	
37	GND	
38	DHS	
39	GND	
40	DVS	
41	GND	
42	DEN	
43	GND	
44	DCLK	
45	GND	

J6:TTL Output FPC Connector

PIN	Function	Note
1	DBRED0	
2	DBRED1	
3	DBRED2	
4	DBRED3	
5	GND	
6	DBRED4	
7	DBRED5	
8	DBRED6	
9	DBRED7	
10	GND	
11	DBGRN0	
12	DBGRN1	
13	DBGRN2	
14	DBGRN3	
15	GND	
16	DBGRN4	
17	DBGRN5	
18	DBGRN6	
19	DBGRN7	
20	GND	
21	DBBLU0	
22	DBBLU1	

www.DataSheet4U.com

23	DBBLU2	
24	DBBLU3	
25	GND	
26	DBBLU4	
27	DBBLU5	
28	DBBLU6	
29	DBBLU7	
30	GND	

Dimension Of Board

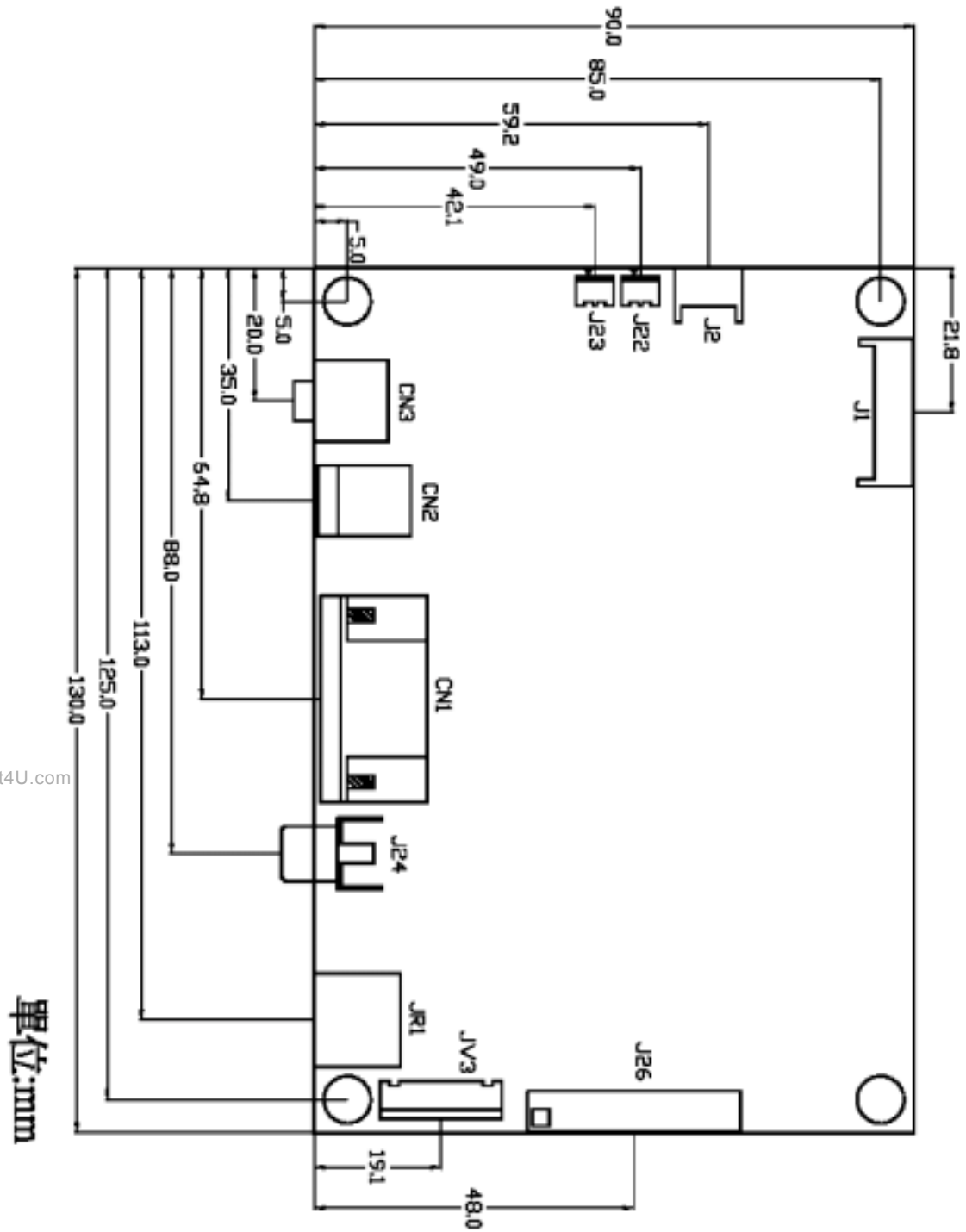

www.DataSheet4U.com

單位:mm