

GENERAL DESCRIPTION

The LD1083 is a low dropout three terminal regulator with 7.5A output current capability. The output voltage is adjustable with the use of a resistor divider or fixed 1.5V/1.8V/2.5V/3.3V/5V. Dropout voltage is guaranteed to be at maximum of 1.5V with the maximum output current. Its low dropout voltage and fast transient response make it ideal for low voltage microprocessor applications. Current limit and thermal protection provide protection against any overload condition that would create excessive junction temperatures.

FEATURES

- ◆ 1.5V Max. Dropout Voltage at 7.5A Output Current.
- ◆ Fast Transient Response.
- ◆ Extremely Tight Line and Load Regulation.
- ◆ Current Limiting and Thermal Protection.
- ◆ Adjustable Output Voltage or Fixed 1.5V, 1.8V,2.5V,3.3V,5.0V.

APPLICATIONS

- Mother Board I/O Power Supplies
- Microprocessor Power Supplies.
- High Current Regulator
- Post Regulator for Switching Supply.
- Notebook Computers

BLOCK DIAGRAM

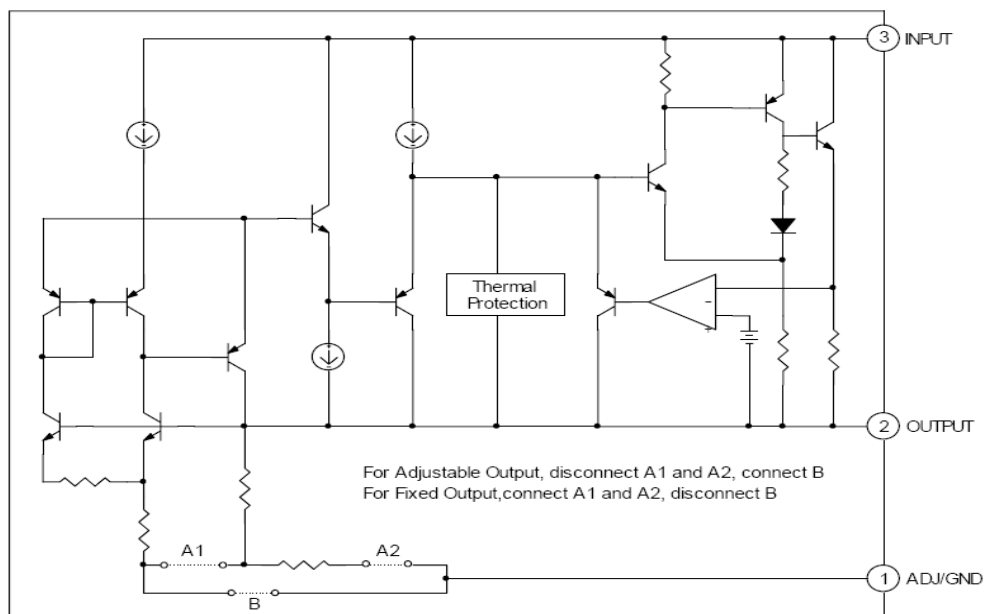

PIN DESCRIPTIONS

ADJ PIN - Providing $V_{REF}=1.25V$ (typ.) for adjustable V_{OUT} . $V_{REF}=V_{OUT}-V_{ADJ}$ and $I_{ADJ}=60\mu A$ (typ.)
 /GND PIN- Power ground.
 VOUT PIN - Adjustable output voltage.
 VIN PIN - Power Input.

TYPICAL APPLICATION CIRCUIT

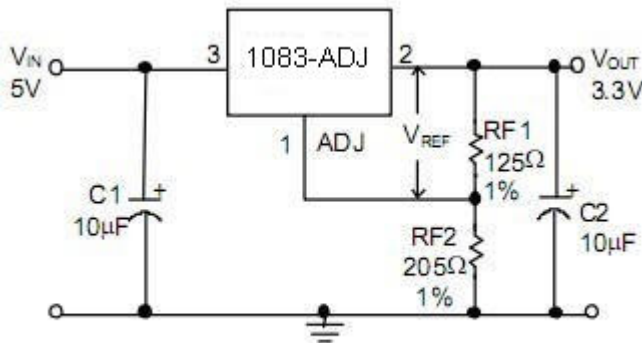

Adjustable Voltage Regulator

$$V_{REF}=V_{OUT} - V_{ADJ}=1.25V \text{ (typ.)}$$

$$V_{OUT}=V_{REF} \times (1+RF2/RF1)+ I_{ADJ} \times RF2$$

$$I_{ADJ}=60\mu A \text{ (typ.)}$$

- (1) capacitors.
- (2) C2 required for stability.

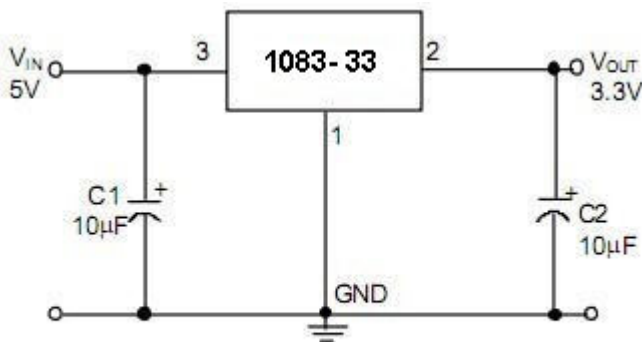

Fixed Voltage Regulator

ORDERING INFORMATION

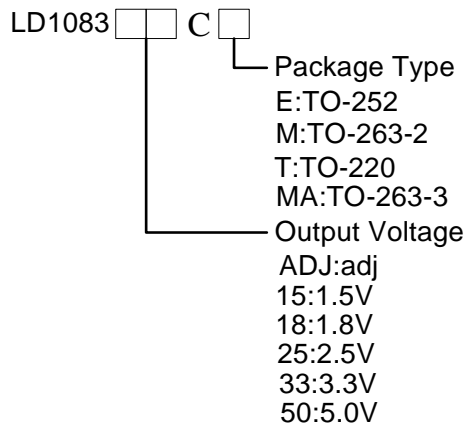

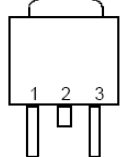
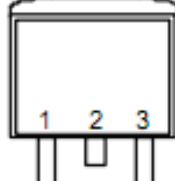
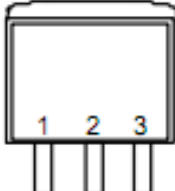
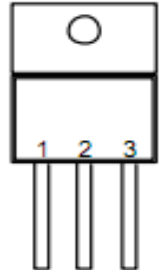
ORDER NUMBER	PIN CONFIGURATION
LD1083CE (TO-252)	FRONT VIEW 1: ADJ (GND) 2: VOUT (TAB) 3: VIN 
LD1083CM (TO-263-2)	FRONT VIEW 1: ADJ (GND) 2: VOUT (TAB) 3: VIN 
LD1083CMA (TO-263-3)	FRONT VIEW 1: ADJ (GND) 2: VOUT (TAB) 3: VIN 
LD1083CT (TO-220)	FRONT VIEW 1: ADJ (GND) 2: VOUT (TAB) 3: VIN 

ABSOLUTE MAXIMUM RATINGS

Input Voltage(Note 1).....	30V
Operating Junction Temperature Range	-20°C~ 125°C
Storage Temperature Range	- 65°C ~ 150°C
Thermal Resistance Junction to Case TO-252	15°C/W
TO-263-3, TO263-2, TO-220.....	6°C /W
Thermal Resistance Junction to Ambient TO-252	100°C/W
(Assume no ambient airflow, no heatsink) TO-263-2 ...	60°C /W
TO-263-3	60°C /W
TO-220	50°C /W
Lead Temperature (Soldering) 10 sec.	260°C

Note 1: Although the devices maximum operating voltage is limited, The devices are guaranteed to withstand transient input voltages up to 30V. For input voltages greater than the maximum operating input voltage some degradation of specifications will occur. For input/output voltage differentials greater than 12V, a minimum external load of 5mA is required to maintain regulation.

ELECTRICAL CHARACTERISTICS (VIN≤10V, TJ=25°C, IO=10mA, Unless otherwise specified)

PARAMETER	TEST CONDITIONS	MIN.	TYP.	MAX.	UNIT
Reference Voltage	LD1083 (ADJ) $1.5V \leq V_{IN} - V_{OUT} \leq 8V$	1.225	1.25	1.275	V
Output Voltage	LD1083-15 LD1083-18 LD1083-25 LD1083-33 LD1083-50	1.470 1.764 2.450 3.235 4.90	1.50 1.80 2.50 3.30 5.00	1.530 1.836 2.550 3.365 5.10	V
Line Regulation	$1.5V \leq V_{IN} - V_{OUT} \leq 10V$		0.02	0.5	%
Load Regulation	$10mA < I_O < 7.5A$			1	%
Dropout Voltage	$I_{OUT}=7.5A, \Delta V_{OUT}=1\% V_{OUT}$		1.3	1.5	V
Current Limit	$V_{IN} - V_{OUT} = 3V$	5.1			A
Adjusted Pin Current	$I_O = 10mA \sim 7.5A$ $1.5V \leq V_{IN} - V_{OUT} \leq 10V$		60	120	uA
Adjusted Pin Current Change(ΔI_{ADJ})	$I_O = 10mA \sim 7.5A$ $1.5V \leq V_{IN} - V_{OUT} \leq 10V$		0.2	5	uA
Temperature Stability	$I_O = 10mA$		0.5		%
Minimum Load Current	$1.5V \leq V_{IN} - V_{OUT} \leq 10V$		5	10	mA
RMS Output Noise (% of V_{OUT})	$10Hz \leq f \leq 10KHz$		0.003		%
Ripple Rejection Ratio	120Hz input ripple $C_{OUT} = 25\mu F$ $(V_{IN} - V_{OUT}) = 3V$		60	72	dB

TYPICAL PERFORMANCE CHARACTERISTICS

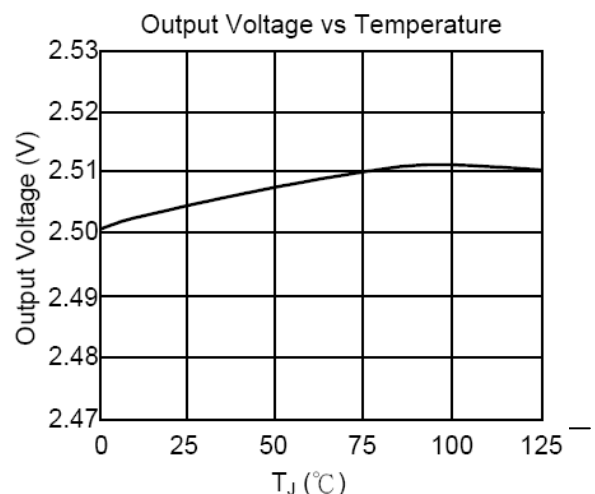
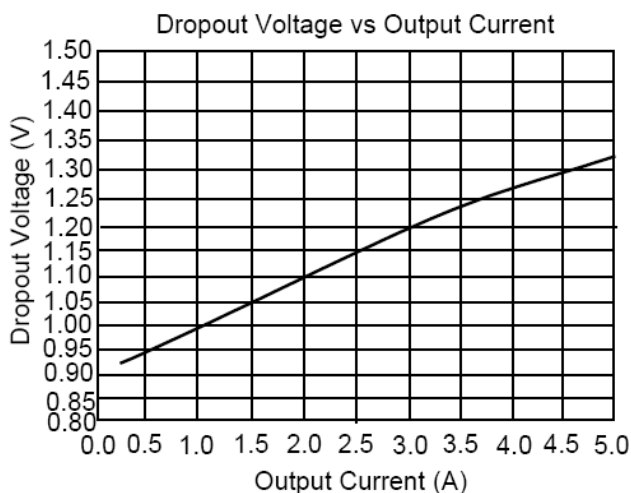

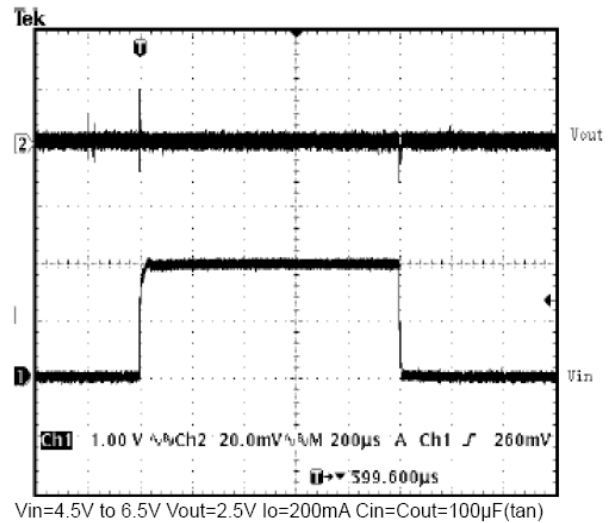
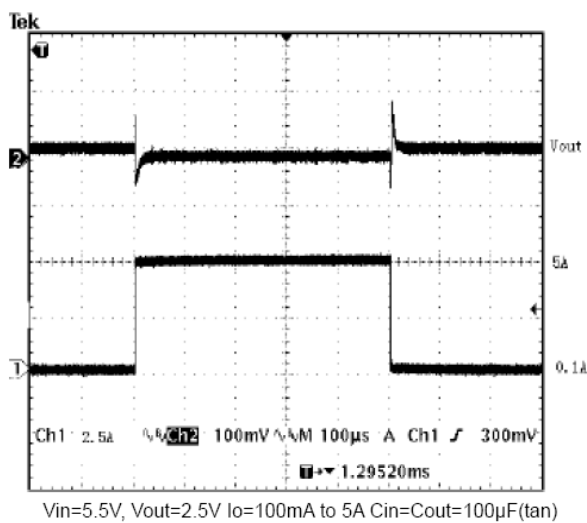
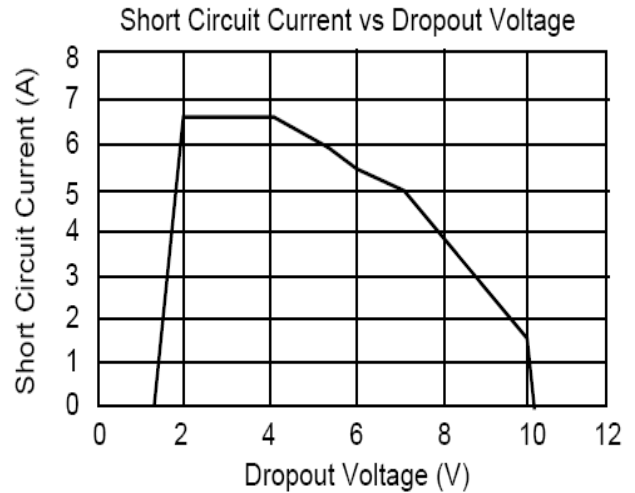
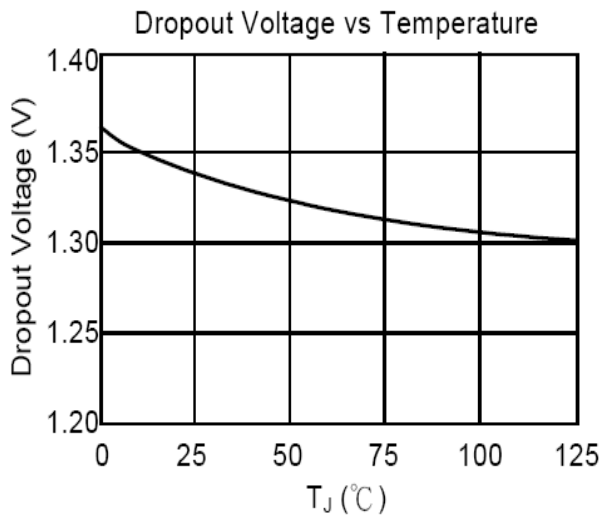
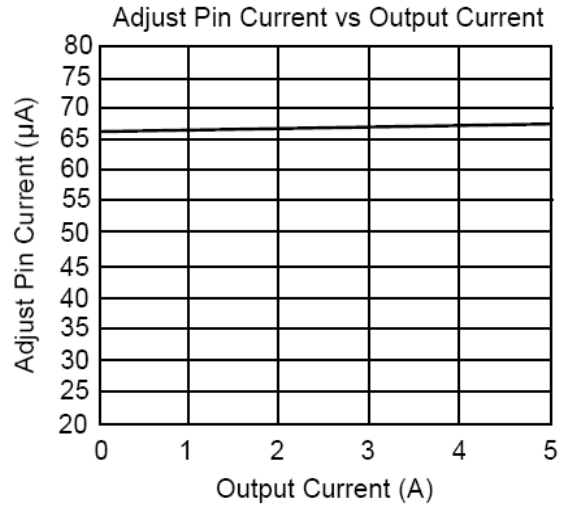
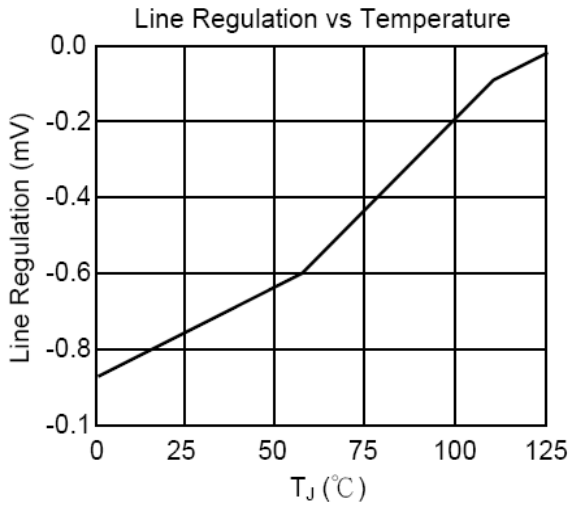

Load Transient Response

Line Transient Response

PACKAGE INFORMATION

TO-263-2

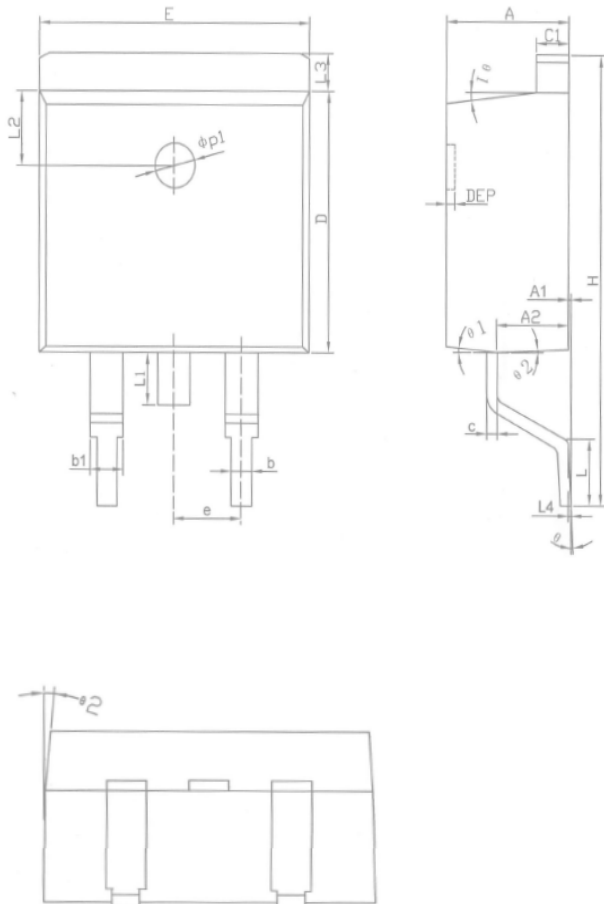

COMMON DIMENSIONS

SYMBOL	MILLIMETER			INCHES		
	MIN	NOM	MAX	MIN	NOM	MAX
A	4.40	4.57	4.70	0.173	0.180	0.185
A1	0	0.10	0.25	0	0.004	0.010
A2	2.59	2.69	2.79	0.102	0.106	0.110
b	0.77	-	0.90	0.030	-	0.035
b1	1.23	-	1.36	0.048	-	0.054
c	0.34	-	0.47	0.013	-	0.019
C1	1.22	-	1.32	0.048	-	0.052
D	8.60	8.70	8.80	0.338	0.343	0.346
E	10.06	10.16	10.26	0.396	0.4	0.404
e	2.54BSC			0.1BSC		
H	14.70	15.10	15.50	0.579	0.594	0.610
L	2.00	2.30	2.60	0.079	0.090	0.102
L3	1.17	1.27	1.40	0.046	0.050	0.055
L1	-	-	1.70	-	-	0.067
L4	0.25BSC			0.01BSC		
L2	2.50REF			0.098REF		
θ	0°	-	8°	0°	-	8°
θ1	5°	7°	9°	5°	7°	9°
θ2	1°	3°	5°	1°	3°	5°
DEP	0.05	0.10	0.20	0.002	0.004	0.008
φp1	1.40	1.50	1.60	0.055	0.059	0.063

NOTES:

1. ALL DIMENSIONS REFER TO JEDEC STANDARD
TO263-2L DO NOT INCLUDE MOLD FLASH
OR PROTRUSIONS

TO-263-3

COMMON DIMENSIONS

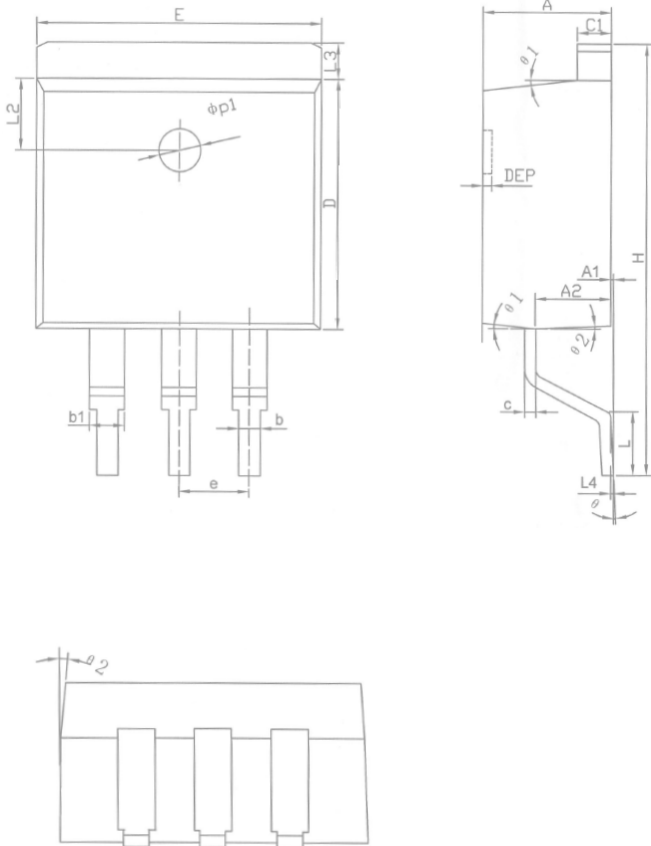

SYMBOL	MILLIMETER			INCHES		
	MIN	NOM	MAX	MIN	NOM	MAX
A	4.40	4.57	4.70	0.173	0.180	0.185
A1	0	0.10	0.25	0	0.004	0.010
A2	2.59	2.69	2.79	0.102	0.106	0.110
b	0.77	-	0.90	0.030	-	0.035
b1	1.23	-	1.36	0.048	-	0.054
c	0.34	-	0.47	0.013	-	0.019
c1	1.22	-	1.32	0.048	-	0.052
D	8.60	8.70	8.80	0.338	0.343	0.346
E	10.06	10.16	10.26	0.396	0.4	0.404
e	2.54BSC			0.1BSC		
H	14.70	15.10	15.50	0.579	0.594	0.610
L	2.00	2.30	2.60	0.079	0.090	0.102
L3	1.17	1.27	1.40	0.046	0.050	0.055
L4	0.25BSC			0.01BSC		
L2	2.50REF			0.098REF		
θ	0°	-	8°	0°	-	8°
θ1	5°	7°	9°	5°	7°	9°
θ2	1°	3°	5°	1°	3°	5°
DEP	0.05	0.10	0.20	0.002	0.004	0.008
φp1	1.40	1.50	1.60	0.055	0.059	0.063

NOTES:

1. ALL DIMENSIONS REFER TO JEDEC STANDARD
TO263-3L DO NOT INCLUDE MOLD FLASH
OR PROTRUSIONS

TO-220

COMMON DIMENSIONS

SYMBOL	MILLIMETER			INCHES		
	MIN	NDM	MAX	MIN	NDM	MAX
A	4.40	4.57	4.70	0.173	0.180	0.185
A1	1.22	-	1.32	0.048	-	0.052
A2	2.59	2.69	2.79	0.102	0.106	0.110
b	0.77	-	0.90	0.030	-	0.035
b2	1.23	-	1.36	0.048	-	0.054
c	0.34	-	0.47	0.013	-	0.019
D	14.70	15.00	15.30	0.579	0.591	0.602
D1	8.60	8.70	8.80	0.338	0.343	0.346
E	10.06	10.16	10.26	0.396	0.400	0.404
e	2.54BSC			0.18BSC		
e1	5.08BSC			0.28BSC		
H1	6.10	6.30	6.50	0.240	0.248	0.256
L	13.15	-	13.57	0.518	-	0.534
L1	-	-	4.35	-	-	0.171
L2	2.50REF			0.098REF		
ϕp	3.80	3.84	3.88	0.149	0.151	0.153
Q	2.60	-	2.90	0.102	-	0.114
$\theta 1$	5°	7°	9°	5°	7°	9°
$\theta 2$	1°	3°	5°	1°	3°	5°
DEP	0.05	0.1	0.2	0.002	0.004	0.008
$\phi p1$	1.4	1.5	1.6	0.055	0.059	0.063

NOTES:

1. ALL DIMENSIONS REFER TO JEDEC STANDARD TO-220AB DO NOT INCLUDE MOLD FLASH OR PROTRUSIONS

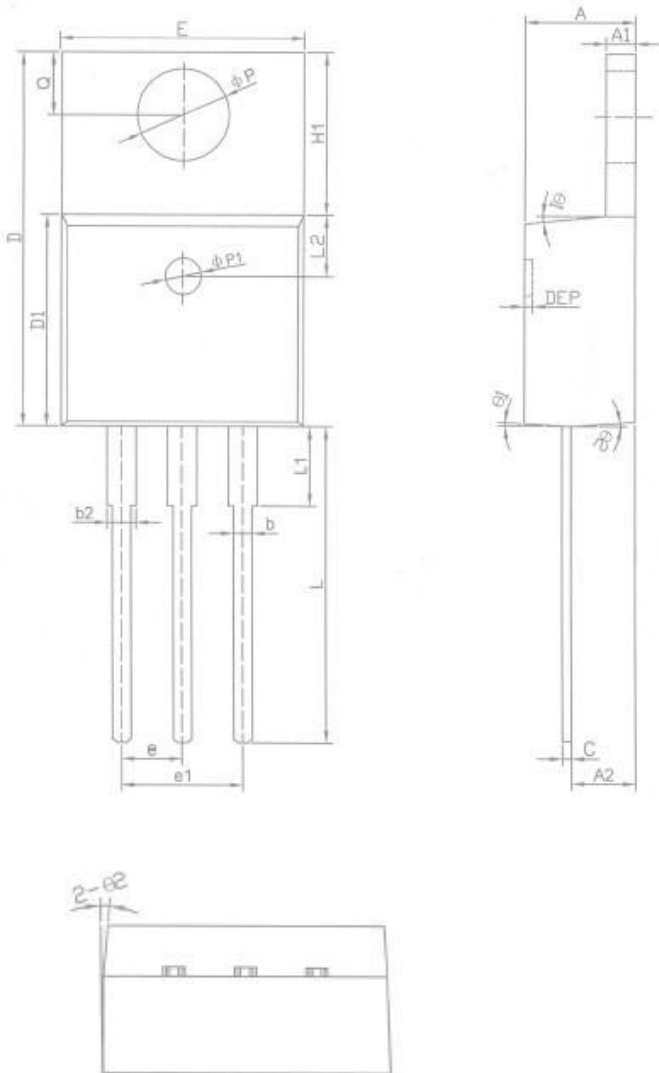

TO-252

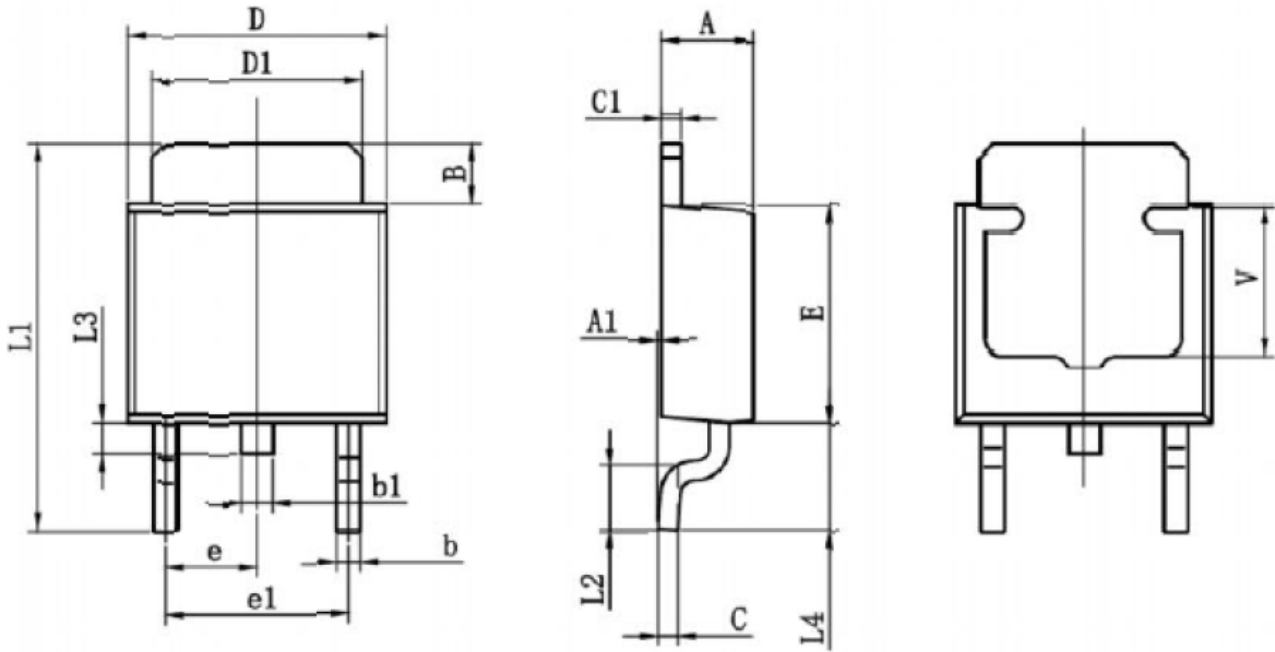

Symbol	Dimensions In Millimeters		Dimensions In Inches	
	Min	Max	Min	Max
A	2.200	2.400	0.087	0.094
A1	0.000	0.127	0.000	0.005
B	1.350	1.650	0.053	0.065
b	0.500	0.700	0.020	0.028
b1	0.700	0.900	0.028	0.035
c	0.430	0.580	0.017	0.023
c1	0.430	0.580	0.014	0.023
D	6.350	6.650	0.250	0.262
D1	5.200	5.400	0.205	0.213
E	5.400	5.700	0.213	0.224
e	2.300TYP		0.0901TYP	
e1	4.500	4.700	0.177	0.185
L1	9.500	9.900	0.374	0.390
L2	1.400	1.780	0.055	0.070
L3	0.650	0.950	0.026	0.037
L4	2.550	2.900	0.100	0.114
V	3.80REF		0.150REF	

Copyright © 2008 by HOTCHIP TECHNOLOGY CO., LTD.

The information appearing in this Data Sheet is believed to be accurate at the time of publication. However, HOTCHIP assumes no responsibility arising from the use of the specifications described. The applications mentioned herein are used solely for the purpose of illustration and HOTCHIP makes no warranty or representation that such applications will be suitable without further modification, nor recommends the use of its products for application that may present a risk to human life due to malfunction or otherwise. HOTCHIP's products are not authorized for use as critical components in life support devices or systems. HOTCHIP reserves the right to alter its products without prior notification. For the most up-to-date information, please visit our web site at <http://www.hotchip.net.cn>.