

SPECIFICATION FOR APPROVAL

Preliminary Specification

Final Specification

Title	42.0" WUXGA TFT LCD
-------	---------------------

BUYER	General
MODEL	

SUPPLIER	LG Display Co., Ltd.
*MODEL	LD420EUN
SUFFIX	UHA1 (RoHS Verified)

APPROVED BY	SIGNATURE DATE
/	
/	
/	

Please return 1 copy for your confirmation with your signature and comments.

APPROVED BY	SIGNATURE DATE
H. J. Song / Team Leader	
REVIEWED BY J.K.Kim / Project Leader	
PREPARED BY D.U.Lee / Engineer	

PD Product Design Dept.
LG Display Co., Ltd

Product Specification

CONTENTS

Number	ITEM	Page
	COVER	0
	CONTENTS	1
	RECORD OF REVISIONS	2
1	GENERAL DESCRIPTION	3
2	ABSOLUTE MAXIMUM RATINGS	4
3	ELECTRICAL SPECIFICATIONS	5
3-1	ELECTRICAL CHARACTERISTICS	5
3-2	INTERFACE CONNECTIONS	7
3-3	SIGNAL TIMING SPECIFICATIONS	9
3-4	SIGNAL TIMING WAVEFORMS	12
3-5	COLOR DATA REFERENCE	15
3-6	POWER SEQUENCE	16
4	OPTICAL SPECIFICATIONS	18
5	MECHANICAL CHARACTERISTICS	22
6	RELIABILITY	25
7	INTERNATIONAL STANDARDS	26
7-1	SAFETY	26
7-2	EMC	26
7-3	ENVIRONMENT	26
8	PACKING	27
8-1	Information of LCM Label	27
8-2	PACKING FORM	27
9	PRECAUTIONS	28
9-1	MOUNTING PRECAUTIONS	28
9-2	OPERATING PRECAUTIONS	28
9-3	ELECTROSTATIC DISCHARGE CONTROL	29
9-4	PRECAUTIONS FOR STRONG LIGHT EXPOSURE	29
9-5	STORAGE	29
9-6	HANDLING PRECAUTIONS FOR PROTECTION FILM	29
9-7	APPROPRATE CONDITION FOR PUBLIC DISPLAY	29

Product Specification

1. General Description

The LD420EUN is a Color Active Matrix Liquid Crystal Display with an integral Light Emitting Diode (LED) backlight system. The matrix employs a-Si Thin Film Transistor as the active element.

It is a transmissive display type which is operating in the normally black mode. It has a 41.92 inch diagonally measured active display area with WUXGA resolution (1080 vertical by 1920 horizontal pixel array). Each pixel is divided into Red, Green and Blue sub-pixels or dots which are arrayed in vertical stripes. Gray scale or the luminance of the sub-pixel color is determined with a 10-bit gray scale signal for each dot. Therefore, it can present a palette of more than 1.07Billion colors.

It has been designed to apply the 10-bit 2-port LVDS interface.

It is intended to support Public Display where high brightness, super wide viewing angle, high color gamut, high color depth and fast response time are important.

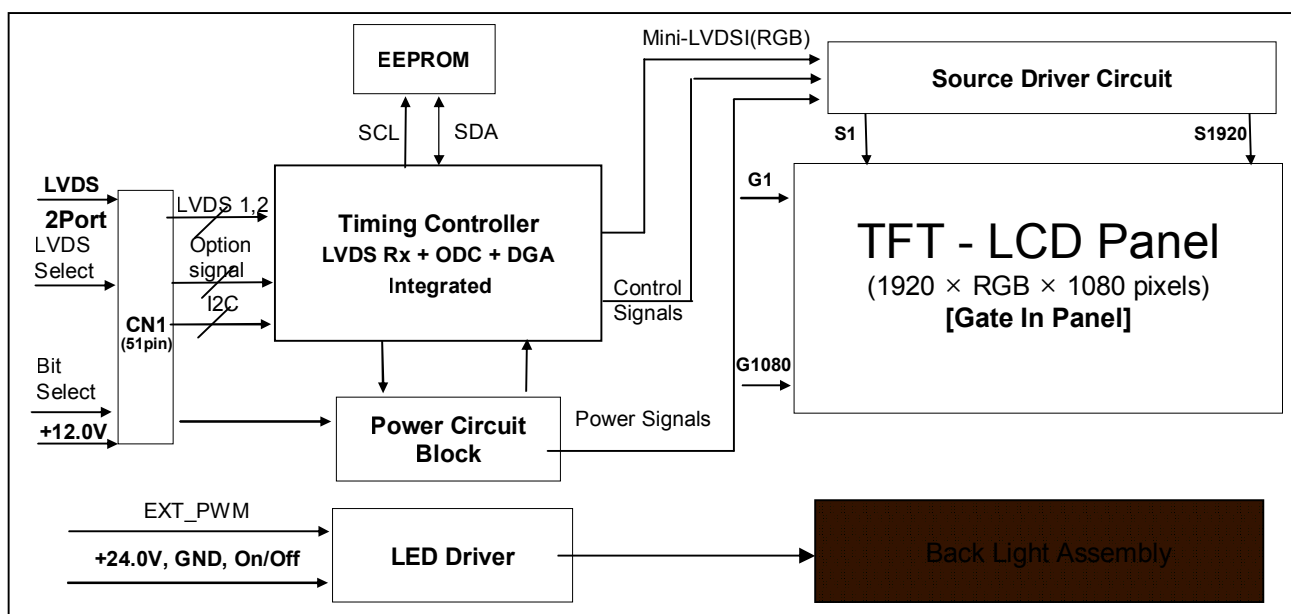

General Features

Active Screen Size	41.92 inches(1064.67mm) diagonal
Outline Dimension	945.74(H) X 539.76(V) X 12.7(B) / 31.2(V) mm (Typ.)
Pixel Pitch	0.4833 mm x 0.4833 mm
Pixel Format	1920 horiz. by 1080 vert. Pixels, RGB stripe arrangement
Color Depth	10bit(D), 1.07 Billion colors
Luminance, White	700 cd/m ² (Center 1point , Typ.)
Viewing Angle (CR>10)	Viewing angle free (R/L 178 (Min.), U/D 178 (Min.))
Power Consumption	Total 81.06W (Typ.) [Logic= 6.72W, LED Driver=74.34W(ExtVbr_B=100%)]
Weight	9.8Kg (Typ.), 10.3Kg(Max.)
Display Mode	Transmissive mode, Normally black
Surface Treatment	Hard coating(3H), Anti-glare treatment of the front polarizer (Haze 10%)
Possible Display Type	Landscape and Portrait Enabled

Product Specification

2. Absolute Maximum Ratings

The following items are maximum values which, if exceeded, may cause faulty operation or permanent damage to the LCD module.

Table 1. ABSOLUTE MAXIMUM RATINGS

Parameter		Symbol	Value		Unit	Notes	
			Min	Max			
Power Input Voltage	LCD Circuit	V _{LCD}	-0.3	+14.0	V _{DC}	1	
	Driver	V _{BL}	-0.3	+ 27.0	V _{DC}		
Driver Control Voltage	ON/OFF	V _{OFF} / V _{ON}	-0.3	+3.9	V _{DC}		
	Brightness	EXTV _{BR-B}	-0.3	+5.5	V _{DC}		
	Status	Status	-0.3	+3.9			
T-Con Option Selection Voltage		V _{LOGIC}	-0.3	+4.0	V _{DC}		
Operating Temperature		T _{OP}	0	+50	°C		2,3
Storage Temperature		T _{ST}	-20	+60	°C		
Panel Front Temperature		T _{SUR}	-	+68	°C		4
Operating Ambient Humidity		H _{OP}	10	90	%RH		2,3
Storage Humidity		H _{ST}	5	90	%RH		

- Notes
1. Ambient temperature condition ($T_a = 25 \pm 2 \text{ }^\circ\text{C}$)
 2. Temperature and relative humidity range are shown in the figure below.
Wet bulb temperature should be Max 39°C, and no condensation of water.
 3. Gravity mura can be guaranteed below 40°C condition.
 4. The maximum operating temperatures is based on the test condition that the surface temperature of display area is less than or equal to 68°C with LCD module alone in a temperature controlled chamber. Thermal management should be considered in final product design to prevent the surface temperature of display area from being over 68°C. The range of operating temperature may be degraded in case of improper thermal management in final product design.

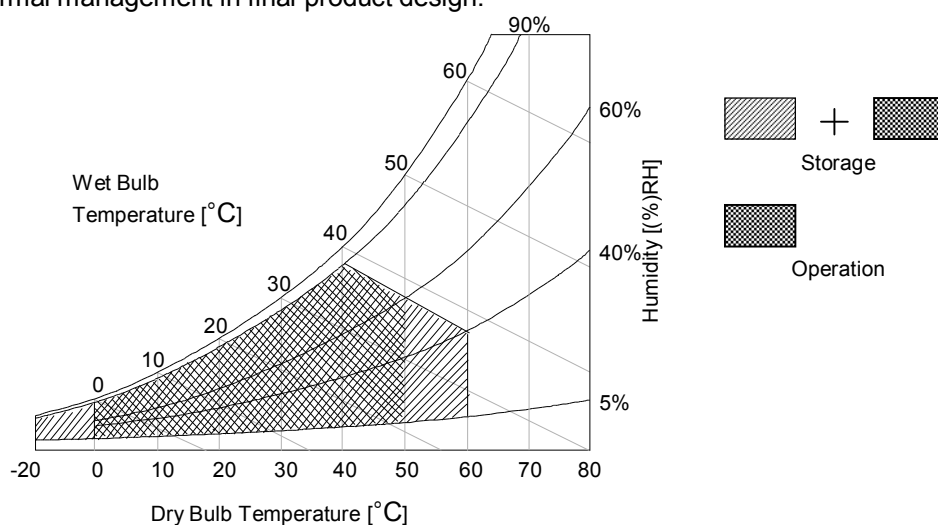

Product Specification

3. Electrical Specifications

3-1. Electrical Characteristics

It requires two power inputs. One is employed to power for the LCD circuit. The other is used for the LED backlight and LED Driver circuit.

Table 2. ELECTRICAL CHARACTERISTICS

Parameter	Symbol	Value			Unit	Note
		Min	Typ	Max		
Circuit :						
Power Input Voltage	V _{LCD}	10.8	12.0	13.2	V _{DC}	5
Power Input Current	I _{LCD}	-	560	728	mA	1
		-	750	975	mA	2
Power Consumption	P _{LCD}	-	6.72	8.74	Watt	1
Rush current	I _{RUSH}	-	-	8.0	A	3

Notes

1. The specified current and power consumption are under the $V_{LCD}=12.0V$, $T_a=25 \pm 2^\circ C$, $f_v=60Hz$ condition, and mosaic pattern(8 x 6) is displayed and f_v is the frame frequency.
2. The current is specified at the maximum current pattern.
3. The duration of rush current is about 2ms and rising time of power input is 0.5ms (min.).
4. Ripple voltage level is recommended under $\pm 5\%$ of typical voltage
5. Maximum of Power Input Voltage is included with ripple.

White : 1023 Gray

Black : 0 Gray

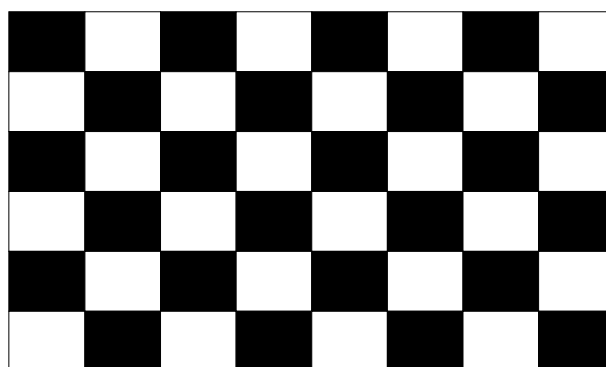

Mosaic Pattern(8 x 6)

Product Specification

Table 3. ELECTRICAL CHARACTERISTICS (Continue)

Parameter		Symbol	Values			Unit	notes	
			Min	Typ	Max			
LED Driver :								
Power Supply Input Voltage		VBL	21.6	24.0	26.4	Vdc	1	
Power Supply Input Current		IBL	-	3.1	3.41	A	1	
Power Supply Input Current (In-Rush)		In-rush	-	-	3.91	A	$V_{BL} = 21.6V$ $ExtV_{BR-B} = 100\%$ 4	
Power Consumption		PBL	-	74.34	81.9	W	1	
Input Voltage for Control System Signals	On/Off	On	V on	2.5	-	3.6	Vdc	On Duty 6
		Off	V off	-0.3	0.0	0.7	Vdc	
	Brightness Adjust	ExtV _{BR-B}	5	-	100	%		
			1	-	100	%		
	ExtV _{BR-B} Frequency	PAL		100		Hz	3	
		NTSC		120		Hz	3	
	Pulse Duty Level (PWM)	High Level	2.5	-	3.6	Vdc	HIGH : on duty LOW : off duty	
Low Level		0.0	-	0.7	Vdc			
LED :								
Life Time			50,000	60,000	-	Hrs	2	

notes :

- Electrical characteristics are determined after the unit has been 'ON' and stable for approximately 60 minutes at $25 \pm 2^\circ C$. The specified current and power consumption are under the typical supply Input voltage 24V and V_{BR} ($ExtV_{BR-B} : 100\%$), it is total power consumption.
- The life time (MTTF) is determined as the time which luminance of the LED is 50% compared to that of initial value at the typical LED current ($ExtV_{BR-B} : 100\%$) on condition of continuous operating in LCM state at $25 \pm 2^\circ C$.
- LGD recommend that the PWM freq. is synchronized with Two time harmonic of V_{sync} signal of system. Though PWM frequency is over 120Hz (max 252Hz), function of LED Driver is not affected.
- The duration of rush current is about 200ms. This duration is applied to LED on time.
- Even though inrush current is over the specified value, there is no problem if I^2T spec of fuse is satisfied.
- $ExtV_{BR-B}$ signal have to input available duty range and sequence.
After Driver ON signal is applied, $ExtV_{BR-B}$ should be sustained from 5% to 100% more than 500ms.
After that, $ExtV_{BR-B}$ 1% and 100% is possible
For more information, please see 3-6-2. Sequence for LED Driver.

Product Specification

3-2. Interface Connections

This LCD module employs two kinds of interface connection, 51-pin connector is used for the module electronics.

3-2-1. LCD Module

- LCD Connector(CN1): FI-RE51S-HF(manufactured by JAE) or GT05P-51S-H38(manufactured by LSM) or IS050-C51B-C39(manufactured by UJU)
- Mating Connector : FI-R51HL(JAE) or compatible

Table 4. MODULE CONNECTOR(CN1) PIN CONFIGURATION

No	Symbol	Description	No	Symbol	Description
1	NC	Note 4	27	Bit Select	'H' = 10bit(D) , 'L' or NC = 8bit
2	NC	Note 4	28	R2AN	SECOND LVDS Receiver Signal (A-)
3	NC	Note 4	29	R2AP	SECOND LVDS Receiver Signal (A+)
4	NC	Note 4	30	R2BN	SECOND LVDS Receiver Signal (B-)
5	NC	Note 4	31	R2BP	SECOND LVDS Receiver Signal (B+)
6	NC	Note 4	32	R2CN	SECOND LVDS Receiver Signal (C-)
7	LVDS Select	'H' =JEIDA , 'L' or NC = VESA	33	R2CP	SECOND LVDS Receiver Signal (C+)
8	NC	Note 4	34	GND	Ground
9	NC	Note 4	35	R2CLKN	SECOND LVDS Receiver Clock Signal(-)
10	NC	Note 4	36	R2CLKP	SECOND LVDS Receiver Clock Signal(+)
11	GND	Ground	37	GND	Ground
12	R1AN	FIRST LVDS Receiver Signal (A-)	38	R2DN	SECOND LVDS Receiver Signal (D-)
13	R1AP	FIRST LVDS Receiver Signal (A+)	39	R2DP	SECOND LVDS Receiver Signal (D+)
14	R1BN	FIRST LVDS Receiver Signal (B-)	40	R2EN	SECOND LVDS Receiver Signal (E-)
15	R1BP	FIRST LVDS Receiver Signal (B+)	41	R2EP	SECOND LVDS Receiver Signal (E+)
16	R1CN	FIRST LVDS Receiver Signal (C-)	42	NC or GND	No Connection or Ground
17	R1CP	FIRST LVDS Receiver Signal (C+)	43	NC or GND	No Connection or Ground
18	GND	Ground	44	GND	Ground
19	R1CLKN	FIRST LVDS Receiver Clock Signal(-)	45	GND	Ground
20	R1CLKP	FIRST LVDS Receiver Clock Signal(+)	46	GND	Ground
21	GND	Ground	47	NC	No connection
22	R1DN	FIRST LVDS Receiver Signal (D-)	48	VLCD	Power Supply +12.0V
23	R1DP	FIRST LVDS Receiver Signal (D+)	49	VLCD	Power Supply +12.0V
24	R1EN	FIRST LVDS Receiver Signal (E-)	50	VLCD	Power Supply +12.0V
25	R1EP	FIRST LVDS Receiver Signal (E+)	51	VLCD	Power Supply +12.0V
26	NC or GND	NC or Ground	-	-	-

notes

1. All GND (ground) pins should be connected together to the LCD module's metal frame.
2. All V_{LCD} (power input) pins should be connected together.
3. All Input levels of LVDS signals are based on the **EIA 644** Standard.
4. **#1~#6 & #8~#9** NC (No Connection): These pins are used only for LGD (Do not connect)
5. LVDS pin (pin No. **#24,25,40,41**) are used for 10Bit(D) of the LCD module.
If used for 8Bit(R), these pins are no connection.
6. Specific pin No. **#44** is used for "No signal detection" of system signal interface.
It should be GND for NSB (No Signal Black) while the system interface signal is not.
If this pin is "H", LCD Module displays AGP (Auto Generation Pattern).

Product Specification

3-2-2. Backlight Module

Master

-LED Driver Connector

: 2002WR - H14B2(Yeonho) or Compatible

- Mating Connector

: 2002HS - 14B2 (Yeonho) or Compatible

Table 5-1. LED DRIVER CONNECTOR PIN CONFIGURATION

Pin No	Symbol	Description	Note
1	VBL	Power Supply +24.0V	
2	VBL	Power Supply +24.0V	
3	VBL	Power Supply +24.0V	
4	VBL	Power Supply +24.0V	
5	VBL	Power Supply +24.0V	
6	GND	Backlight Ground	1
7	GND	Backlight Ground	
8	GND	Backlight Ground	
9	GND	Backlight Ground	
10	GND	Backlight Ground	
11	Status	Back Light Status	2
12	VON/OFF	Backlight ON/OFF control	4
13	NC	Don't care	
14	EXTVBR-B	External PWM	3

Notes :1. GND should be connected to the LCD module's metal frame.

2. Normal : Low (under 0.7V) / Abnormal : Open

3. High : on duty / Low : off duty, Pin#14 can be opened. (if Pin #14 is open , EXTVBR-B is 100%)

4. Each impedance of pin #12 and 14 is over 50 [KΩ] .

◆ Rear view of LCM

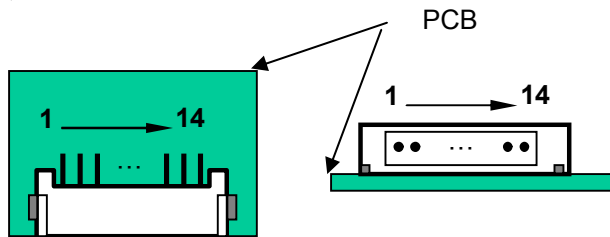

<Master>

◆ Status

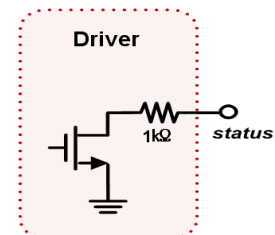

Product Specification

3-3. Signal Timing Specifications

Table 6 shows the signal timing required at the input of the LVDS transmitter. All of the interface signal timings should be satisfied with the following specification for normal operation.

Table 6. TIMING TABLE (DE Only Mode)

ITEM		Symbol	Min	Typ	Max	Unit	notes
Horizontal	Display Period	t _{HV}	960	960	960	tCLK	1920 / 2
	Blank	t _{HB}	100	140	240	tCLK	1
	Total	t _{HP}	1060	1100	1200	tCLK	
Vertical	Display Period	t _{VV}	1080	1080	1080	Lines	
	Blank	t _{VB}	20	45	300	Lines	1
	Total	t _{VP}	1100	1125	1380	Lines	

ITEM		Symbol	Min	Typ	Max	Unit	notes
Frequency	DCLK	f _{CLK}	60.00	74.25	78.00	MHz	
	Horizontal	f _H	57.3	67.5	70	KHz	2
	Vertical	f _V	47	60	63	Hz	2

Note: 1. The input of HSYNC & VSYNC signal does not have an effect on normal operation (DE Only Mode).
If you use spread spectrum of EMI, add some additional clock to minimum value for clock margin.

2. The performance of the electro-optical characteristics may be influenced by variance of the vertical refresh rate and the horizontal frequency

3. Spread Spectrum Rate (SSR) for 50KHz ~ 100kHz Modulation Frequency(FMOD) is calculated by $(7 - 0.06 \cdot F_{mod})$, where Modulation Frequency (F_{MOD}) unit is KHz.
LVDS Receiver Spread spectrum Clock is defined as below figure

※ Timing should be set based on clock frequency.

Product Specification

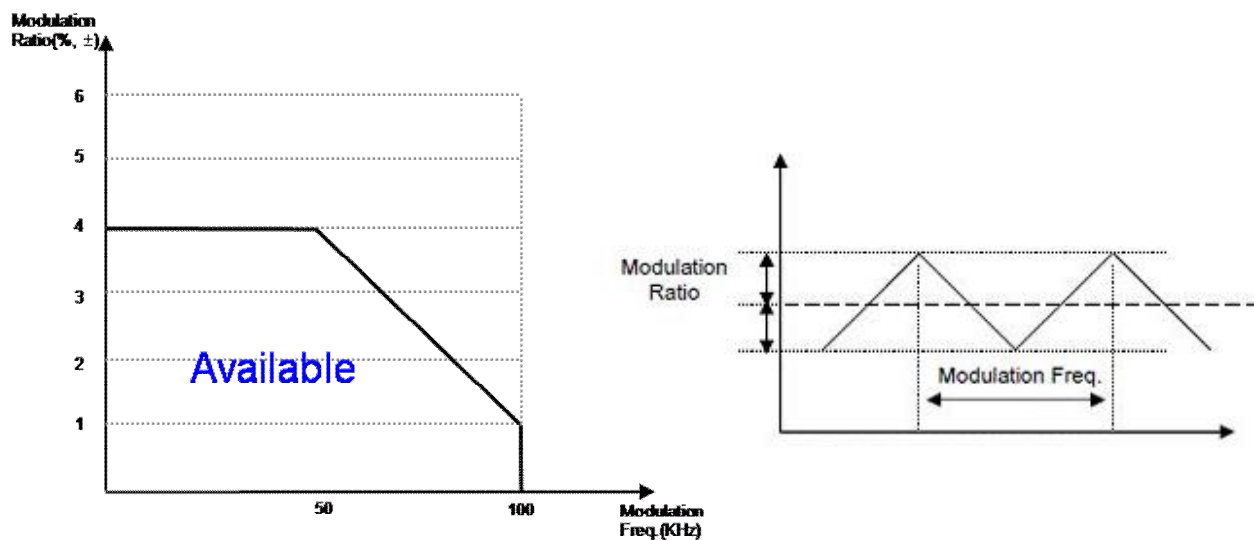

※ Please pay attention to the followings when you set Spread Spectrum Rate(SSR) and Modulation Frequency(FMOD)

1. Please set proper Spread Spectrum Rate(SSR) and Modulation Frequency (FMOD) of TV system LVDS output.
2. Please check FOS after you set Spread Spectrum Rate(SSR) and Modulation Frequency(FMOD) to avoid abnormal display. Especially, harmonic noise can appear when you use Spread Spectrum under FMOD 30 KHz.

Product Specification

3-4. LVDS Signal Specification

3-4-1. LVDS Input Signal Timing Diagram

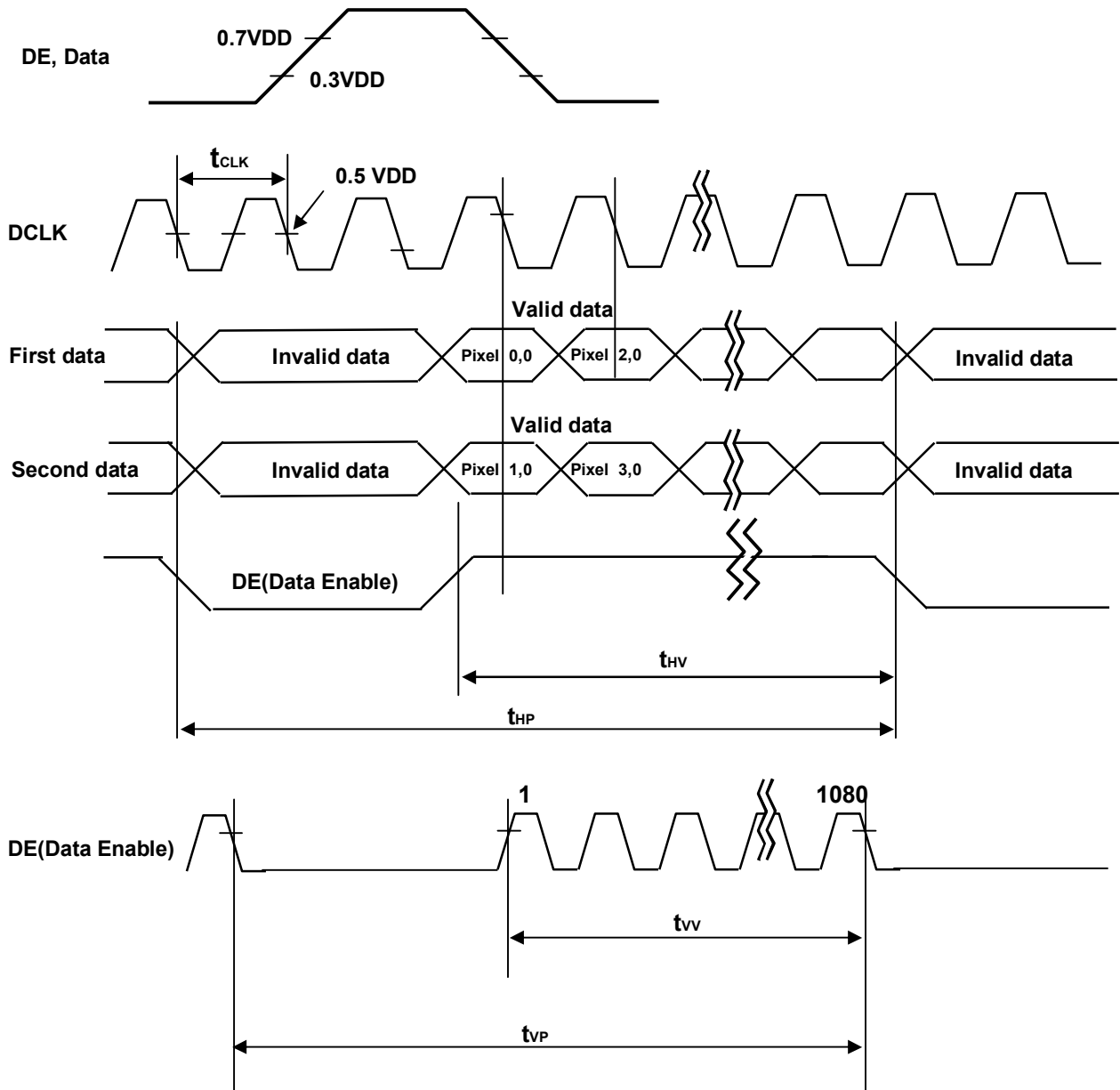

Product Specification

3-4-2. LVDS Input Signal Characteristics

1) DC Specification

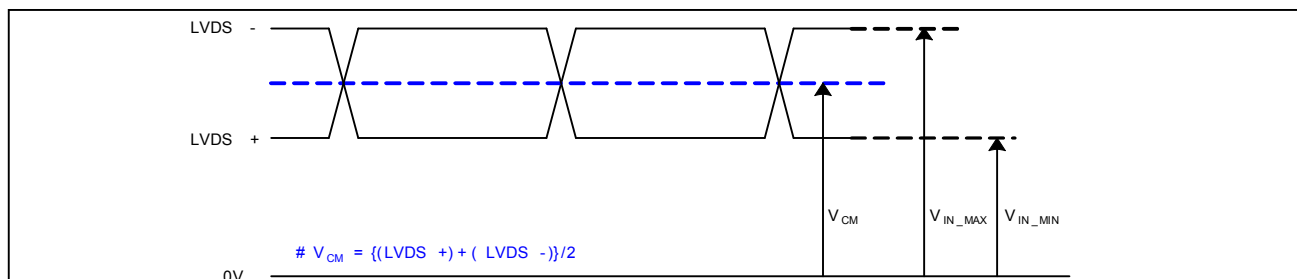

Description	Symbol	Min	Max	Unit	notes
LVDS Common mode Voltage	V_{CM}	1.0	1.5	V	-
LVDS Input Voltage Range	V_{IN}	0.7	1.8	V	-
Change in common mode Voltage	ΔV_{CM}	-	250	mV	-

2) AC Specification

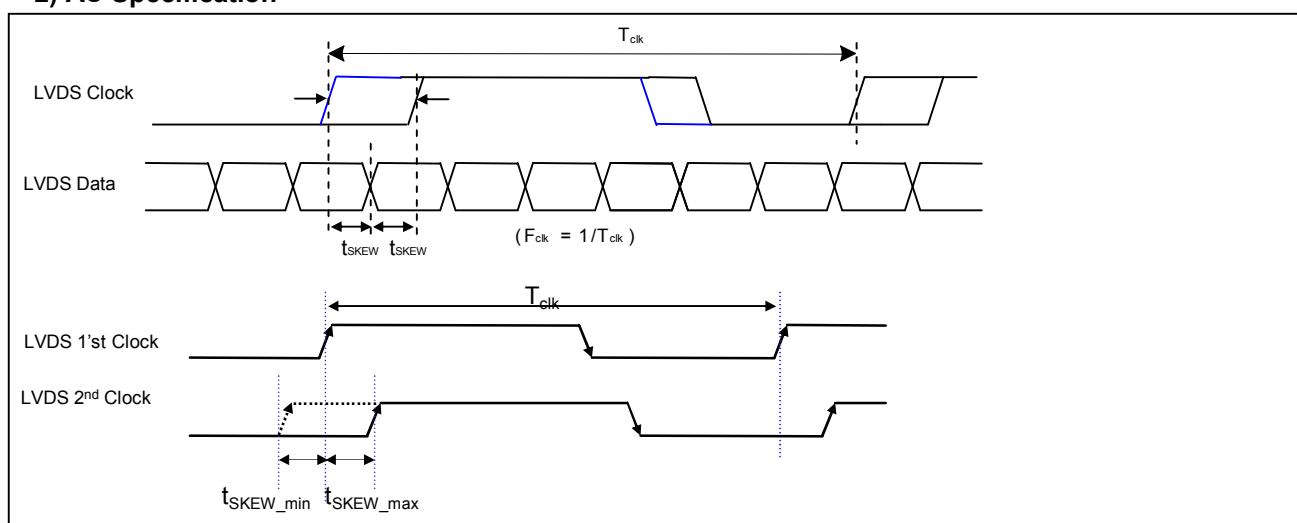

Description	Symbol	Min	Max	Unit	notes
LVDS Differential Voltage	V_{TH}	100	600	mV	Tested with Differential Probe 2
	V_{TL}	-600	-100	mV	
LVDS Clock to Data Skew	t_{SKEW}	-	$ (0.25 \cdot T_{clk})/7 $	ps	-
Effective time of LVDS	t_{eff}	$ \pm 360 $	-	ps	-
LVDS Clock to Clock Skew (Even to Odd)	t_{SKEW_EO}	-	$ 1/7 \cdot T_{clk} $	ps	-

notes 1. All Input levels of LVDS signals are based on the EIA 644 Standard.

2. LVDS Differential Voltage is defined within t_{eff}

Product Specification

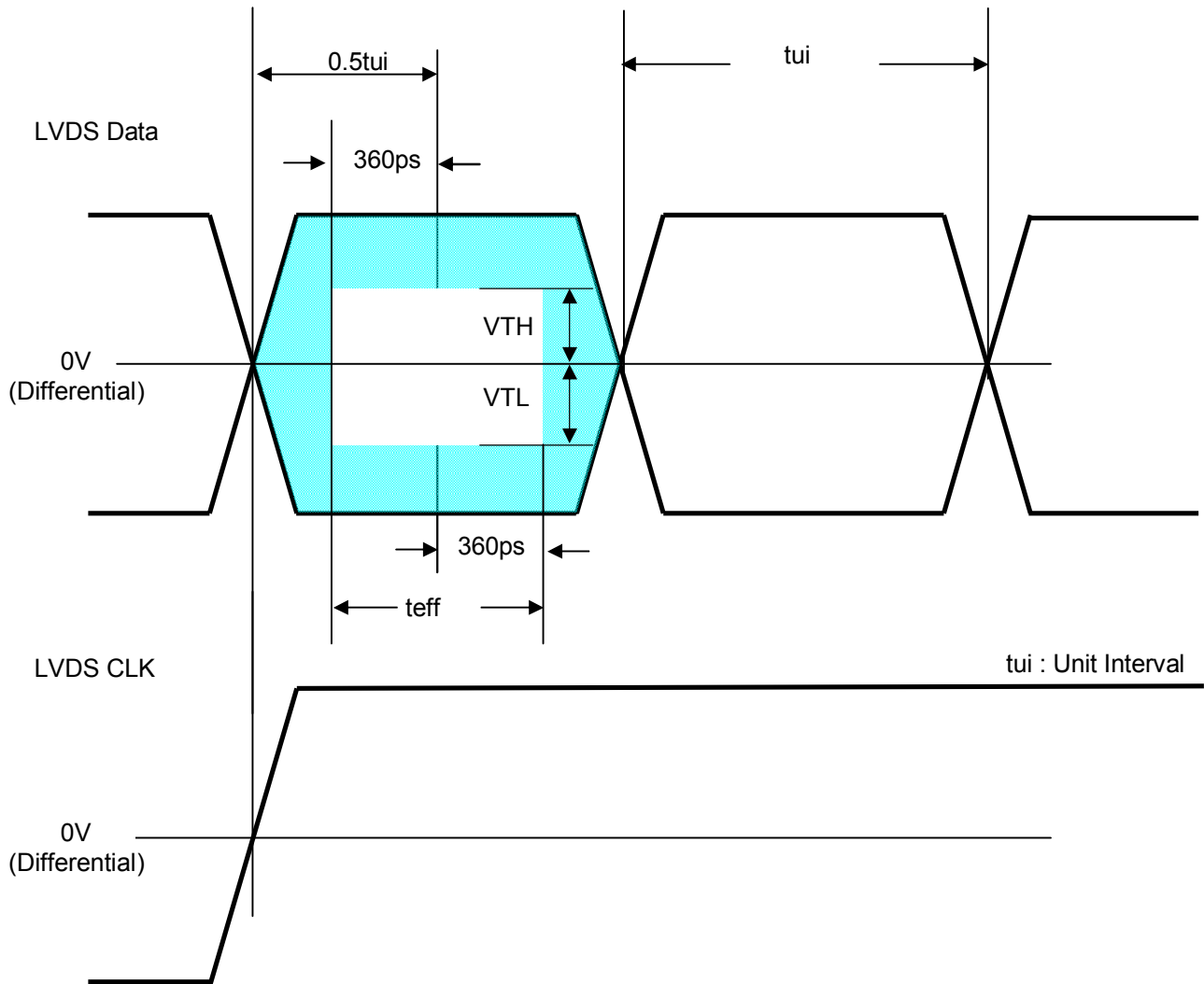

* This accumulated waveform is tested with differential probe

Product Specification

3-6. Power Sequence

3-6-1. LCD Driving circuit

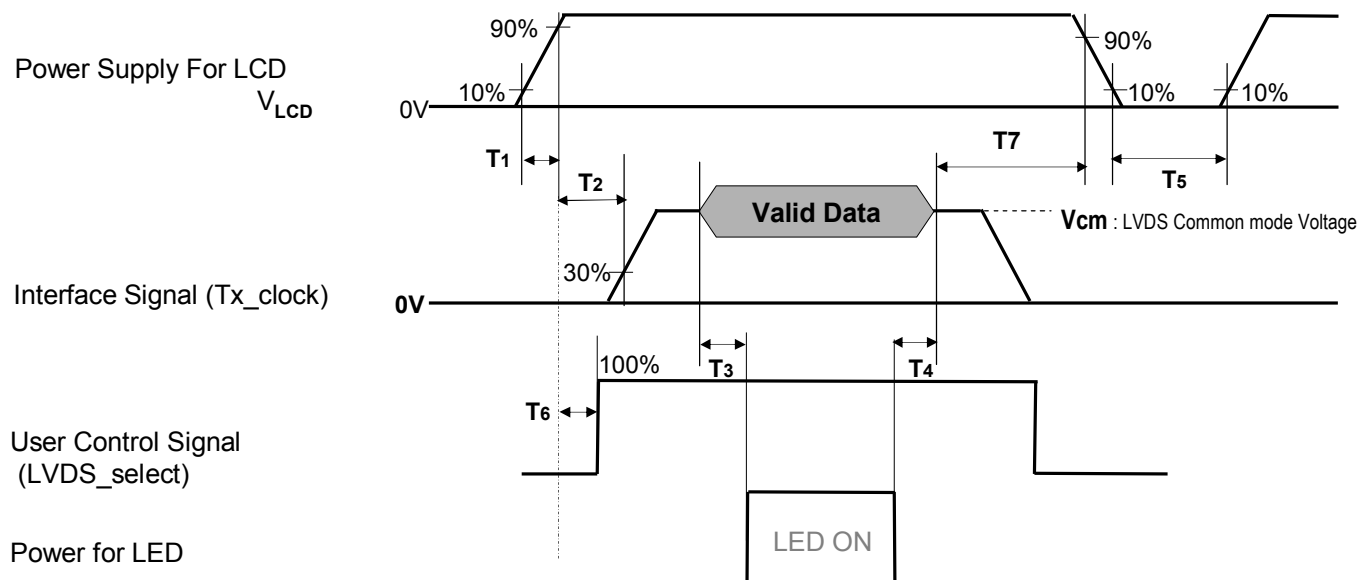

Table 8. POWER SEQUENCE

Parameter	Value			Unit	Notes
	Min	Typ	Max		
T1	0.5	-	20	ms	1
T2	0	-	-	ms	2
T3	400	-	-	ms	3
T4	100	-	-	ms	3
T5	1.0	-	-	s	4
T6	0	-	T2	ms	5
T7	0	-	-	ms	6

- Note :
1. Even though T1 is over the specified value, there is no problem if I2T spec of fuse is satisfied.
 2. If T2 is satisfied with specification after removing LVDS Cable, there is no problem.
 3. The T3 / T4 is recommended value, the case when failed to meet a minimum specification, abnormal display would be shown. There is no reliability problem.
 4. T5 should be measured after the Module has been fully discharged between power off and on period.
 5. If the on time of signals (Interface signal and user control signals) precedes the on time of Power (V_{LCD}), it will be happened abnormal display. When T6 is NC status, T6 doesn't need to be measured.
 6. It is recommendation specification that T7 has to be 0ms as a minimum value.
 - ※ Please avoid floating state of interface signal at invalid period.
 - ※ When the power supply for LCD (V_{LCD}) is off, be sure to pull down the valid and invalid data to 0V.

Product Specification

3-6-2. Sequence for LED Driver

Power Supply For LED Driver

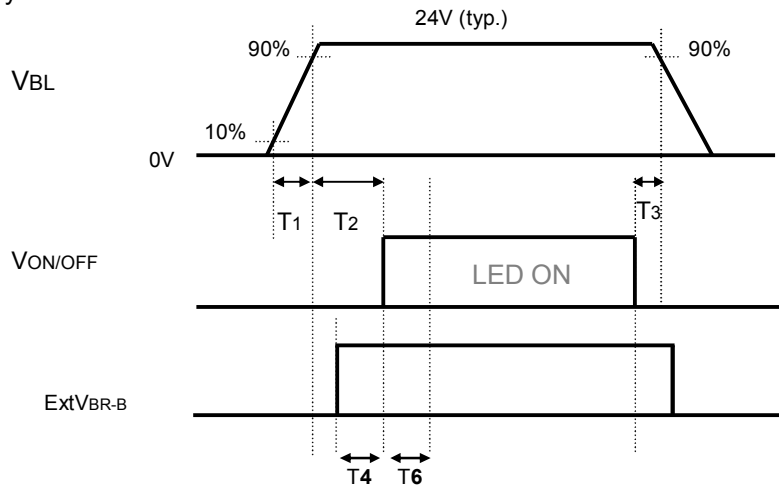

3-6-3. Dip condition for LED Driver

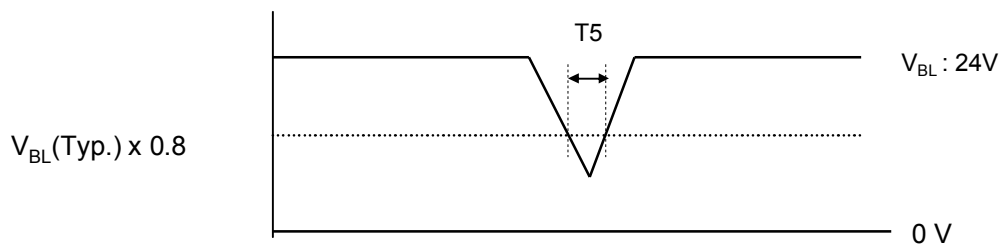

Table 9. Power Sequence for LED Driver

Parameter	Values			Units	Remarks
	Min	Typ	Max		
T1	20	-	-	ms	1
T2	500	-	-	ms	
T3	10	-	-	ms	
T4	0	-	-	ms	
T5	-	-	10	ms	$V_{BL}(Typ) \times 0.8$
T6	500	-	-	ms	2

- Notes : 1. T1 describes rising time of 0V to 24V and this parameter does not applied at restarting time.
 Even though T1 is over the specified value, there is no problem if I²T spec of fuse is satisfied.
 2. In T6 section, ExtVBR-B should be sustained from 5% to 100% .

Product Specification

4. Optical Specification

Optical characteristics are determined after the unit has been 'ON' and stable in a dark environment at $25\pm 2^{\circ}\text{C}$. The values are specified at 50cm from the LCD surface at a viewing angle of Φ and θ equal to 0° . FIG. 1 shows additional information concerning the measurement equipment and method.

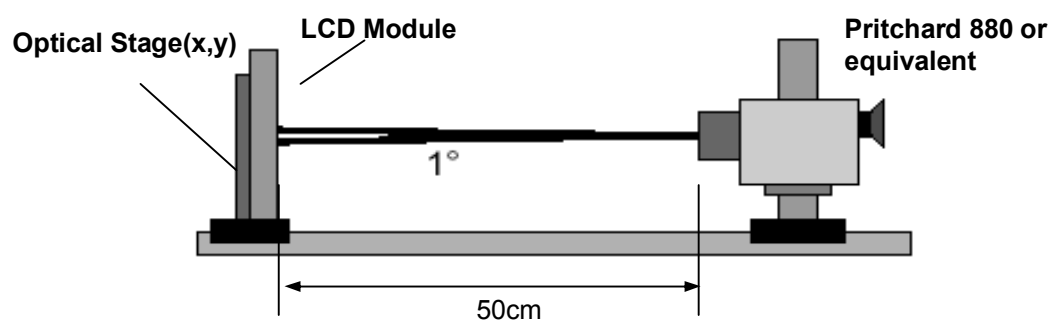

FIG. 1 Optical Characteristic Measurement Equipment and Method

Table 10. OPTICAL CHARACTERISTICS

$T_a = 25\pm 2^{\circ}\text{C}$, $V_{\text{LCD}} = 12.0\text{V}$, $f_v = 60\text{Hz}$, $D_{\text{clk}} = 74.25\text{MHz}$,
EXTV_{BR-B} = 100%

Parameter	Symbol	Value			Unit	notes	
		Min	Typ	Max			
Contrast Ratio	CR	900	1300	-		1	
Surface Luminance, white	L_{WH}	560	700	-	cd/m^2	2	
Luminance Variation	δ_{WHITE} 9P	65		-	%	3	
Response Time	Gray-to-Gray	G ot G	8	12	ms	4	
	Uniformity	$\delta_{\text{G TO G}}$	-	1		5	
Color Coordinates [CIE1931]	RED	Rx	0.651	Typ +0.03			
		Ry	0.334				
	GREEN	Gx	0.309				
		Gy	0.601				
	BLUE	Bx	0.151				
		By	0.058				
	WHITE	Wx	0.279				
Wy	0.292						
Color Temperature			10,000		K		
Color Gamut			72		%		
Viewing Angle (CR>10)							
	x axis, right ($\phi=0^{\circ}$)	θ_r	89	-	-	degree	6
	x axis, left ($\phi=180^{\circ}$)	θ_l	89	-	-		
	y axis, up ($\phi=90^{\circ}$)	θ_u	89	-	-		
	y axis, down ($\phi=270^{\circ}$)	θ_d	89	-	-		
Gray Scale			-	-	-		7

Product Specification

Note : 1. Contrast Ratio(CR) is defined mathematically as :

$$CRn = \frac{\text{Surface Luminance with all white pixels}}{\text{Surface Luminance with all black pixels}}$$

It is measured at center 1-point.

2. Surface luminance are determined after the unit has been 'ON' and 1 Hour after lighting the backlight in a dark environment at $25 \pm 2^\circ\text{C}$. Surface luminance is the luminance value at center 1-point across the LCD surface 50cm from the surface with all pixels displaying white. For more information see the FIG. 2.
3. The variation in surface luminance, δ WHITE is defined as :
 δ WHITE(9P) = Minimum ($L_{on1}, L_{on2} \sim L_{on8}, L_{on9}$) / Maximum ($L_{on1}, L_{on2} \sim L_{on8}, L_{on9}$)*100
 Where L_{on1} to L_{on9} are the luminance with all pixels displaying white at 9 locations .
 For more information, see the FIG. 2.
4. Response time is the time required for the display to transit from G(N) to G(M) (Rise Time, Tr_R) and from G(M) to G(N) (Decay Time, Tr_D). For additional information see the FIG. 3.($N < M$)
 ※ G to G Spec stands for average value of all measured points.
 Photo Detector : RD-80S / Field : 2°
5. Viewing angle is the angle at which the contrast ratio is greater than 10. The angles are determined for the horizontal or x axis and the vertical or y axis with respect to the z axis which is normal to the LCD module surface. For more information, see the FIG. 4.
6. Gray scale specification
 Gamma Value is approximately 2.2. For more information, see the Table 11.

Table 11. Gray scale specification

	계조	상대휘도(%) OPC OFF 상대휘도(%)			비고
		최소	정격	최대	
0	L0	-	0.07	0.29	
1	L63	0.11	0.27	1.15	
2	L127	0.32	1.04	2.26	
3	L191	0.83	2.49	4.45	
4	L255	1.90	4.68	7.98	
5	L319	3.97	7.66	11.96	
6	L383	6.26	11.5	16.96	
7	L447	9.41	16.1	23.11	
8	L511	13.0	21.6	30.53	
9	L575	18.5	28.1	38.81	
10	L639	24.2	35.4	47.78	
11	L703	30.7	43.7	56.99	
12	L767	38.9	53.0	67.14	
13	L831	49.2	63.2	77.38	
14	L895	60.5	74.5	87.50	
15	L959	77.3	86.7	95.34	
16	L1023	100	100	100	

Product Specification

Measuring point for surface luminance & measuring point for luminance variation.

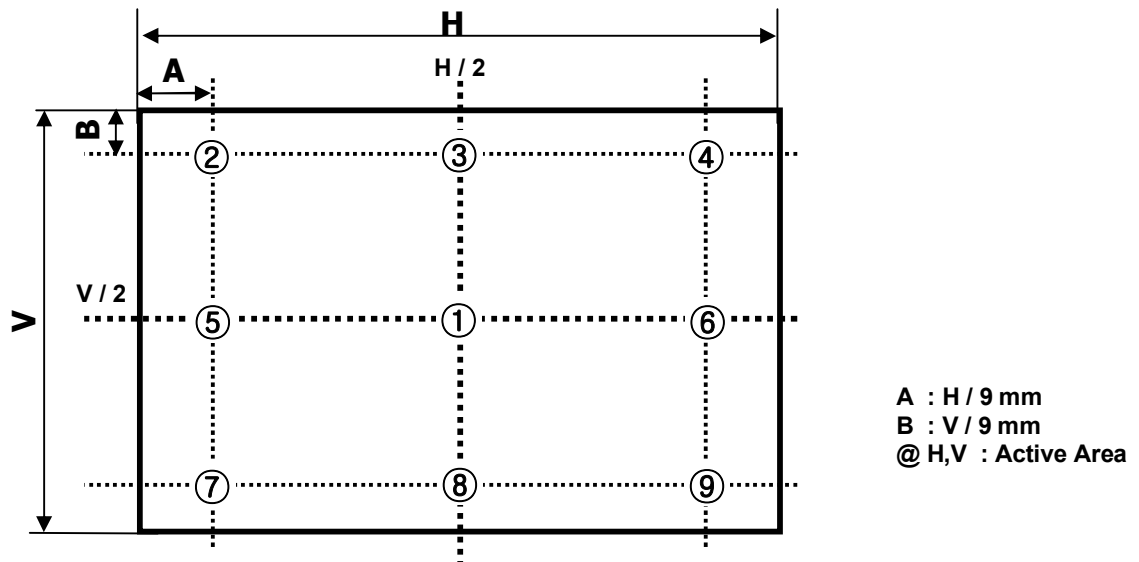

FIG. 2 9 Points for Luminance Measure

Response time is defined as the following figure and shall be measured by switching the input signal for "Gray(N)" and "Gray(M)".

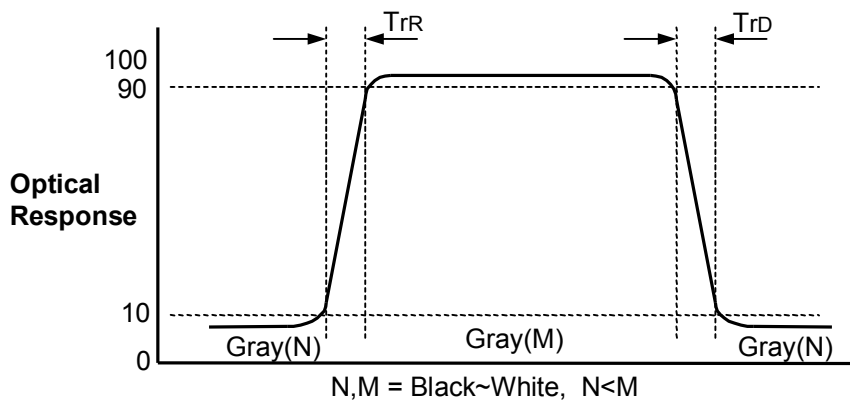

FIG. 3 Response Time

Dimension of viewing angle range

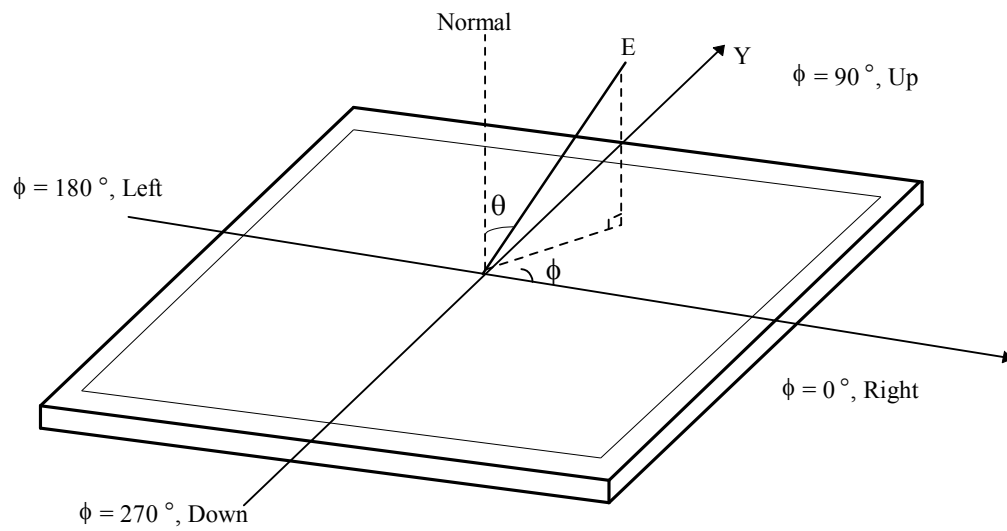

FIG. 4 Viewing Angle

5. Mechanical Characteristics

Table 12 provides general mechanical characteristics.

Table 12. MECHANICAL CHARACTERISTICS

Item	Value	
Outline Dimension	Horizontal	945.74 mm
	Vertical	539.76 mm
	Depth	12.7 mm
Bezel Area	Horizontal	933.94mm
	Vertical	527.96mm
Active Display Area	Horizontal	927.94 mm
	Vertical	521.96 mm
Weight	9.8 Kg (Typ.) 10.3 kg (Max.)	

Note : Please refer to a mechanical drawing in terms of tolerance at the next page.

Product Specification

[FRONT VIEW]



SET : TOP

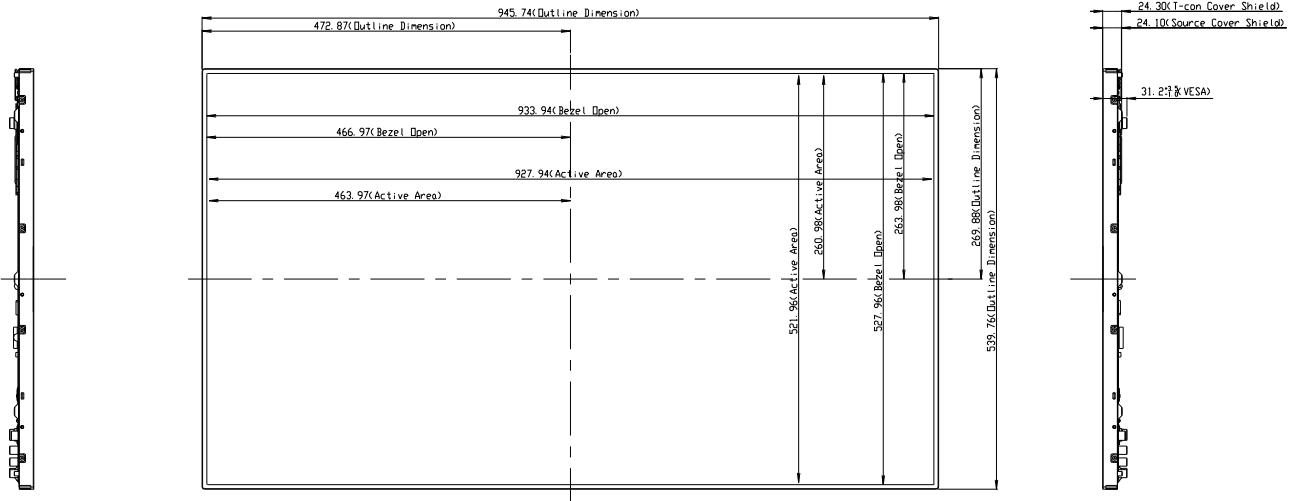

SET : DOWN

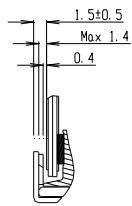
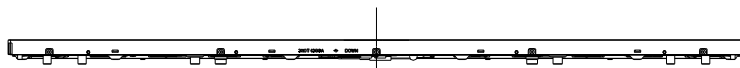

NOTES V2.0

1. UNSPECIFIED TOLERANCE IS ±1.0mm.
2. TILT AND PARTIAL DISPOSITION TOLERANCE OF DISPLAY AREA AS FOLLOWING.
 - (a) X-DIRECTION : (A-B) \leq 1.5mm.
 - (b) Y-DIRECTION : (C-D) \leq 1.5mm.
3. Max. TORQUE : REFER TO TABLE.
4. Max. DEPTH : REFER TO TABLE.
5. THE SAME FEATURE MEANS THE SAME DIMENSION.

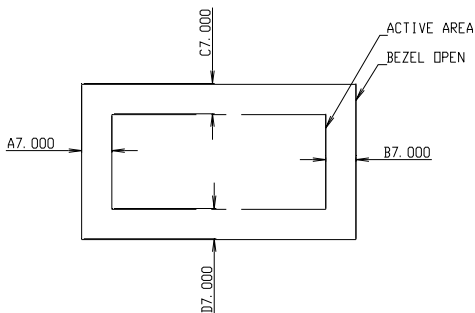

Date	Version
Aug. 12. 2014	V1.0
Aug. 22. 2014	V2.0

Product Specification

[REAR VIEW]

Set : Top

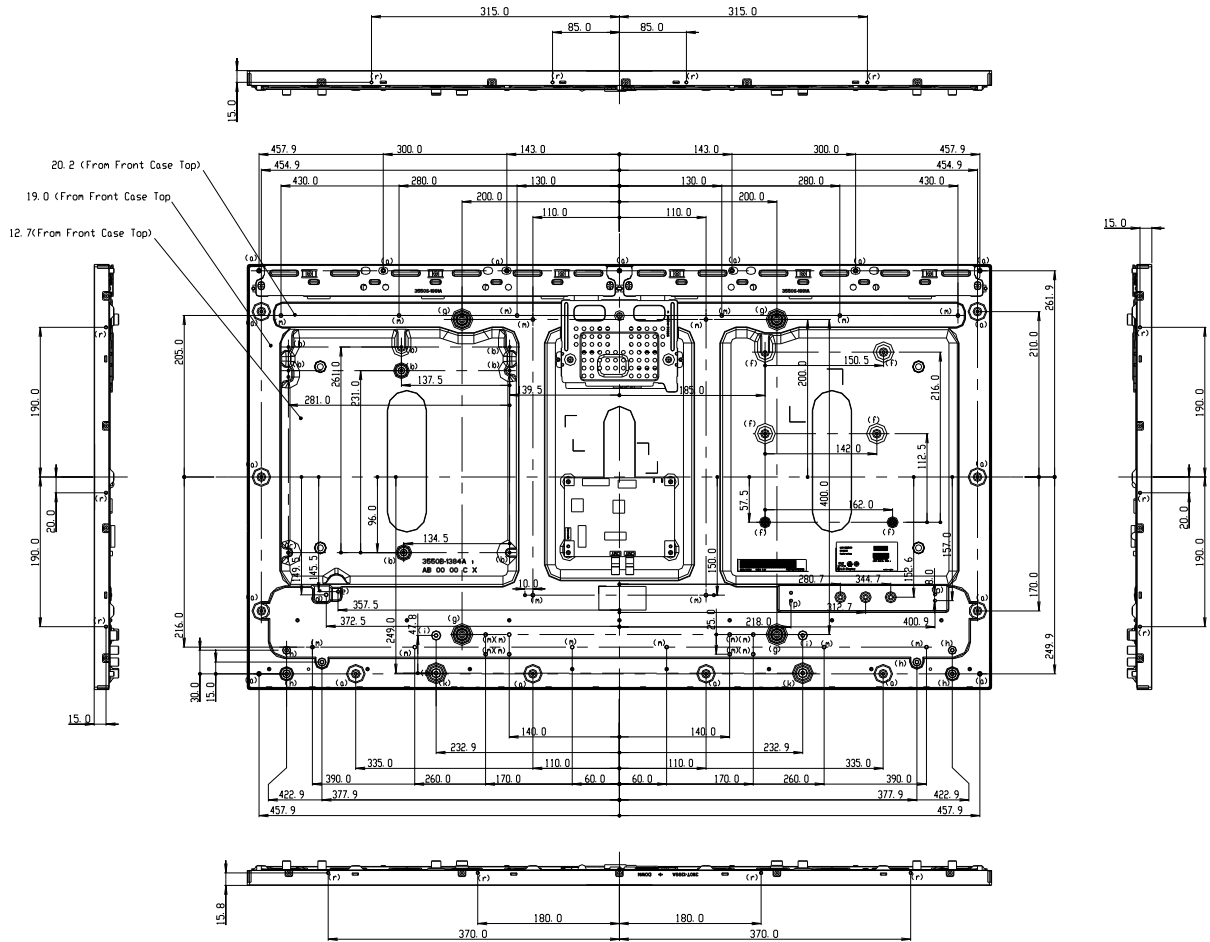

Set : Down

ITEM	TAP	UDM Height (mm)	Max Depth (mm)	Torque (kgf. cm)	Notes
(a)	M3.0	6.1	4.0	MAX 8.0	
(b)	M3.0	5.0	4.0	MAX 8.0	
(c)	M4.0	5.0	4.0	MAX 8.0	
(d)	M4.0	5.7	4.0	MAX 8.0	
(e)	M3.0	8.8	8.0	MAX 8.0	
(f)	M3.0	6.0	5.5	Max 8.0	
(g)	M6.0	11.0	10.0	MAX 15.0	
(h)	M4.0	11.0	8.5	MAX 8.0	
(i)	M4.0	9.0	5.5	MAX 8.0	
(k)	M4.0	12.2	5.5	MAX 8.0	
(m)	M4.0	-	4.5	MAX 8.0	
(p)	M3.0	-	4.5	MAX 8.0	
(r)	M3.0	-	8.5	MAX 8.0	

Product Specification

6. Reliability**Table 13. ENVIRONMENT TEST CONDITION**

No.	Test Item	Condition
1	High temperature storage test	Ta= 60°C 90% 240h
2	Low temperature storage test	Ta= -20°C 240h
3	High temperature operation test	Ta= 50°C 50%RH 500h
4	Low temperature operation test	Ta= 0°C 500h
5	Vibration test (non-operating)	Wave form : random Vibration level : 0.7Grms Bandwidth : 10-300Hz Duration : X,Y,Z, Each direction per 10 min
6	Shock test (non-operating)	Shock level : 20Grms Waveform : half sine wave, 14ms Direction : ±X, ±Y, ±Z One time each direction
7	Humidity condition Operation	Ta= 40 °C ,90%RH
8	Altitude operating storage / shipment	0 - 16,400 ft 0 - 40,000 ft

Note : 1. Before and after Reliability test, LCM should be operated with normal function.

2. These conditions are for LGD's internal test. Please refer to Absolute Maximum Ratings (Table1) for guaranteed condition.

7. International Standards

7-1. Safety

- a) UL 60065, Underwriters Laboratories Inc.
Audio, Video and Similar Electronic Apparatus - Safety Requirements.
- b) CAN/CSA C22.2 No.60065:03, Canadian Standards Association.
Audio, Video and Similar Electronic Apparatus - Safety Requirements.
- c) EN 60065, European Committee for Electrotechnical Standardization (CENELEC).
Audio, Video and Similar Electronic Apparatus - Safety Requirements.
- d) IEC 60065, The International Electrotechnical Commission (IEC).
Audio, Video and Similar Electronic Apparatus - Safety Requirements.

7-2. Environment

- a) RoHS, Directive 2011/65/EU of the European Parliament and of the council of 8 June 2011

Product Specification

8. Packing**8-1. Information of LCM Label**

a) Lot Mark

A	B	C	D	E	F	G	H	I	J	K	L	M
---	---	---	---	---	---	---	---	---	---	---	---	---

A,B,C : SIZE(INCH)
E : MONTH

D : YEAR
F ~ M : SERIAL NO.

Note

1. YEAR

Year	2011	2012	2013	2014	2015	2016	2017	2018	2019	2020
Mark	A	B	C	D	E	F	G	H	J	K

2. MONTH

Month	Jan	Feb	Mar	Apr	May	Jun	Jul	Aug	Sep	Oct	Nov	Dec
Mark	1	2	3	4	5	6	7	8	9	A	B	C

b) Location of Lot Mark

Serial NO. is printed on the label. The label is attached to the backside of the LCD module.
This is subject to change without prior notice.

8-2. Packing Form

a) Package quantity in one Pallet : 22 pcs

b) Pallet Size : 1300 mm(W) X 1140 mm(D) X 772 mm(H)

9. Precautions

Please pay attention to the followings when you use this TFT LCD module.

9-1. Mounting Precautions

- (1) You must mount a module using specified mounting holes (Details refer to the drawings).
- (2) You should consider the mounting structure so that uneven force (ex. Twisted stress, Concentrated stress) is not applied to the module. And the case on which a module is mounted should have sufficient strength so that external force is not transmitted directly to the module.
- (3) Please attach the surface transparent protective plate to the surface in order to protect the polarizer. Transparent protective plate should have sufficient strength in order to resist external force.
- (4) You should adopt radiation structure to satisfy the temperature specification.
- (5) Acetic acid type and chlorine type materials for the cover case are not desirable because the former generates corrosive gas of attacking the polarizer at high temperature and the latter causes circuit break by electro-chemical reaction.
- (6) Do not touch, push or rub the exposed polarizers with glass, tweezers or anything harder than HB pencil lead. And please do not rub with dust clothes with chemical treatment. Do not touch the surface of polarizer for bare hand or greasy cloth. (Some cosmetics are detrimental to the polarizer.)
- (7) When the surface becomes dusty, please wipe gently with absorbent cotton or other soft materials like chamois soaks with petroleum benzine. Normal-hexane is recommended for cleaning the adhesives used to attach front / rear polarizers. Do not use acetone, toluene and alcohol because they cause chemical damage to the polarizer
- (8) Wipe off saliva or water drops as soon as possible. Their long time contact with polarizer causes deformations and color fading.
- (9) Do not open the case because inside circuits do not have sufficient strength.
- (10) Touching the LED Driver might cause an electric shock and damage to LED Driver. Please always use antistatic tools when handling the LED Driver

9-2. Operating Precautions

- (1) Response time depends on the temperature. (In lower temperature, it becomes longer.)
- (2) Brightness depends on the temperature. (In lower temperature, it becomes lower.)
And in lower temperature, response time (required time that brightness is stable after turned on) becomes longer
- (3) Be careful for condensation at sudden temperature change. Condensation makes damage to polarizer or electrical contacted parts. And after fading condensation, smear or spot will occur.
- (4) When fixed patterns are displayed for a long time, remnant image is likely to occur.
- (5) Module has high frequency circuits. Sufficient suppression to the electromagnetic interference shall be done by system manufacturers. Grounding and shielding methods may be important to minimize the interference.
- (6) Please do not give any mechanical and/or acoustical impact to LCM. Otherwise, LCM can't be operated its full characteristics perfectly.
- (7) A screw which is fastened up the steels should be a machine screw.
(if not, it can cause conductive particles and deal LCM a fatal blow)
- (8) Please do not set LCD on its edge.
- (9) The conductive material and signal cables are kept away from LED driver inductor to prevent abnormal display, sound noise and temperature rising.

9-3. Electrostatic Discharge Control

Since a module is composed of electronic circuits, it is not strong to electrostatic discharge. Make certain that treatment persons are connected to ground through wrist band etc. And don't touch interface pin directly.

9-4. Precautions for Strong Light Exposure

Strong light exposure causes degradation of polarizer and color filter.

9-5. Storage

When storing modules as spares for a long time, the following precautions are necessary.

- (1) Store them in a dark place. Do not expose the module to sunlight or fluorescent light. Keep the temperature between 5°C and 35°C at normal humidity.
- (2) The polarizer surface should not come in contact with any other object.
It is recommended that they be stored in the container in which they were shipped.
- (3) Storage condition is guaranteed under packing conditions.
- (4) The phase transition of Liquid Crystal in the condition of the low or high storage temperature will be recovered when the LCD module returns to the normal condition.

9-6. Appropriate Condition for Commercial Display

- Generally large-sized LCD modules are designed for consumer applications (TV).

Accordingly, a long-term display like in Commercial Display application, can cause uneven display including image sticking. To optimize module's lifetime and function, several operating usages are required.

1. Normal operating condition

- Temperature: 0 ~ 40°C
 - Operating Ambient Humidity : 10 ~ 90 %
 - Display pattern: dynamic pattern (Real display)
- Note) Long-term static display can cause image sticking.

2. Operating usages under abnormal condition

a. Ambient condition

- Well-ventilated place is recommended to set up Commercial Display system.

b. Power and screen save

- Periodical power-off or screen save is needed after long-term display.

Product Specification

3. Operating usages to protect against image sticking due to long-term static display
 - a. Suitable operating time: under 18 hours a day.
 - b. Static information display recommended to use with moving image.
 - Cycling display between 5 minutes' information(static) display and 10 seconds' moving image.
 - c. Background and character (image) color change
 - Use different colors for background and character, respectively.
 - Change colors themselves periodically.
 - d. Avoid combination of background and character with large different luminance.
 - 1) Abnormal condition just means conditions except normal condition.
 - 2) Black image or moving image is strongly recommended as a screen save.
4. Lifetime in this spec. is guaranteed only when Commercial Display is used according to operating usages.
5. Module should be turned clockwise based on front view when used in portrait mode.

Product Specification

APPENDIX-I

■ Pallet Ass'y

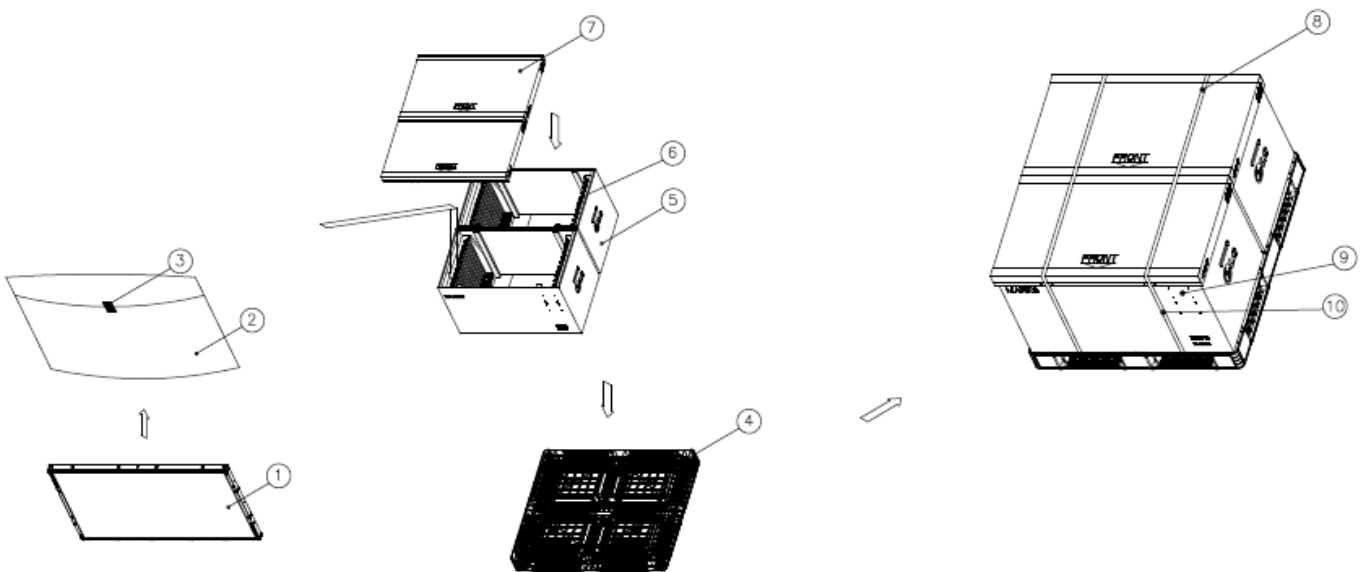

NO.	DESCRIPTION	MATERIAL
1	LCD Module	LD420EUN-UHA1
2	BAG	AL
3	TAPE	MASKING 20MMX50M
4	PALLET	Plastic 1300X1140X120.0mm
5	PACKING,BOTTOM	PAPER
6	PACKING,BOTTOM PAD	EPS
7	PACKING, TOP	PAPER
8	BAND	PP
9	LABEL	YUPO 80G 100X70
10	BAND CLIP	STEEL OR PP

Product Specification

APPENDIX- II-1

■ LCM Label



■ Production site

– LG Display (Paju, New Optics) Co., LTD

notes 1.The origin of LCM Label will be changed according to the production site.

Product Specification

APPENDIX- II-2

■ Pallet Label



APPENDIX- III-1

■ Required signal assignment for Flat Link (Thine : THC63LVD103) Transmitter(Pin7= “L”)

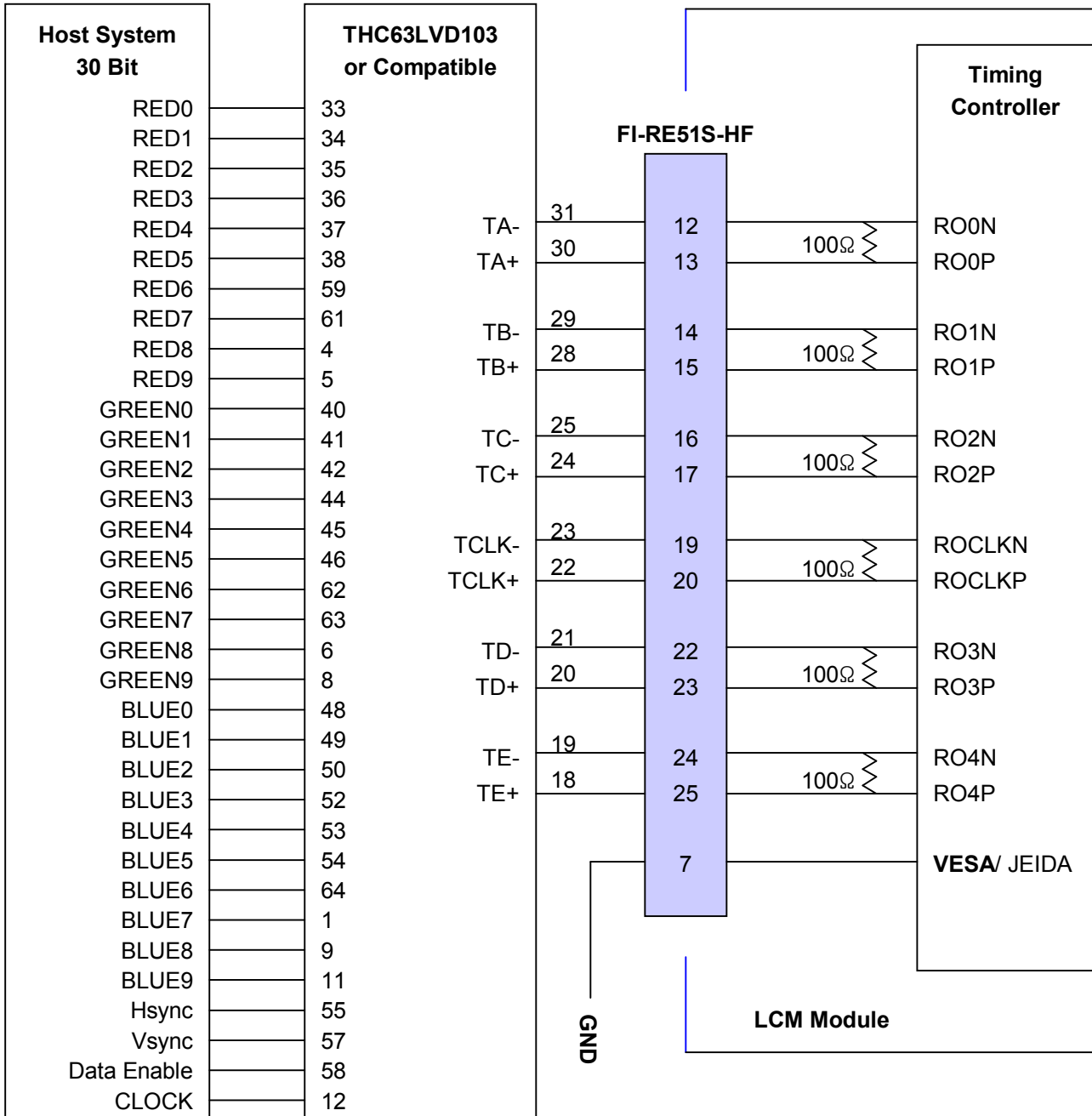

Note: 1. The LCD module uses a 100 Ohm[Ω] resistor between positive and negative lines of each receiver input.

2. Refer to LVDS Transmitter Data Sheet for detail descriptions. (THC63LVD103 or Compatible)

3. '9' means MSB and '0' means LSB at R,G,B pixel data.

APPENDIX- III-2

■ Required signal assignment for Flat Link (Thine : THC63LVD103) Transmitter(Pin7= "H")

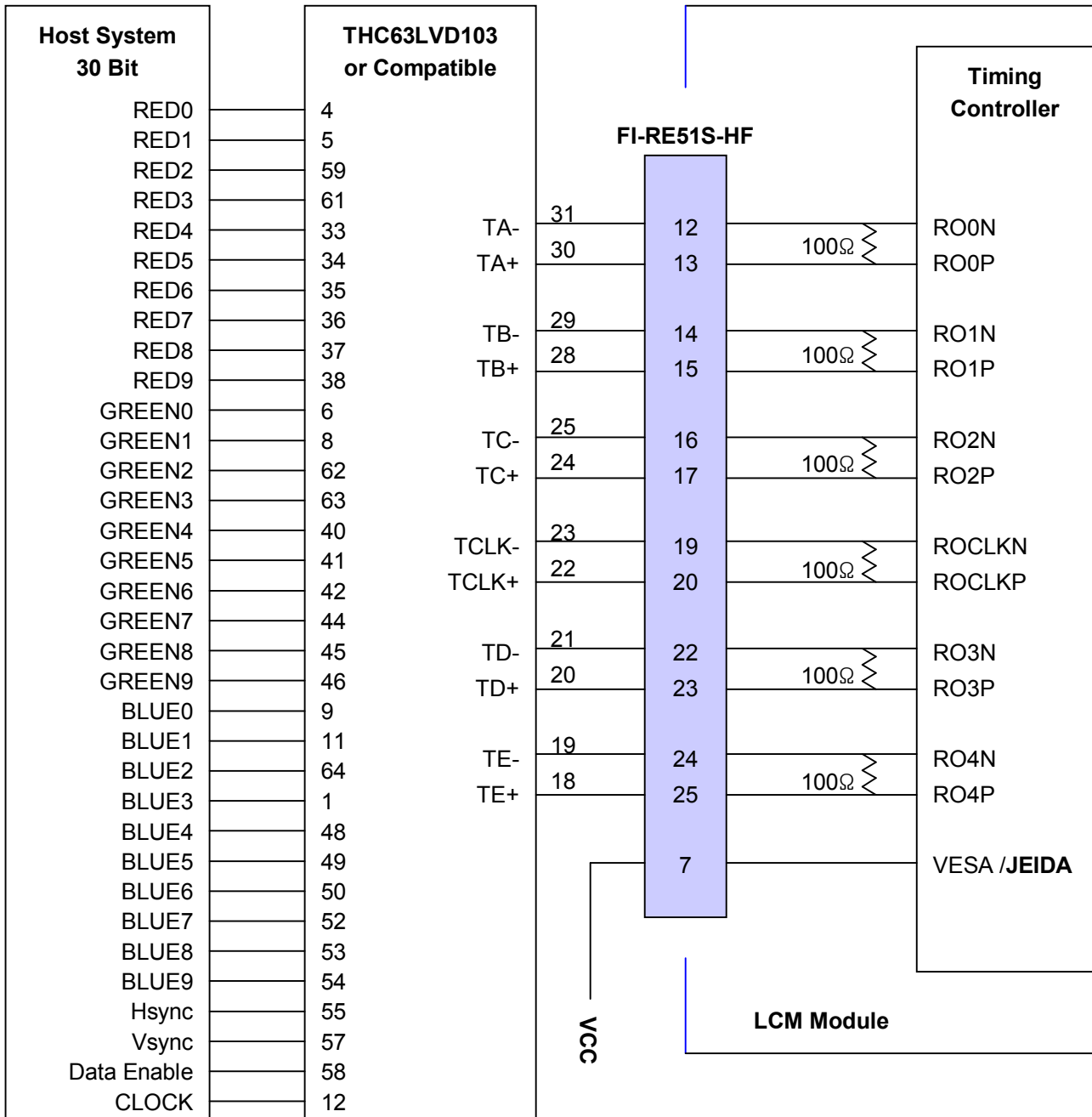

Note :1. The LCD module uses a 100 Ohm[Ω] resistor between positive and negative lines of each receiver input.

2. Refer to LVDS Transmitter Data Sheet for detail descriptions. (THC63LVD103 or Compatible)

3. '9' means MSB and '0' means LSB at R,G,B pixel data.

APPENDIX- IV

■ LVDS Data-Mapping Information (10 Bit)

1) LVDS Select : "H" Data-Mapping (JEIDA format)

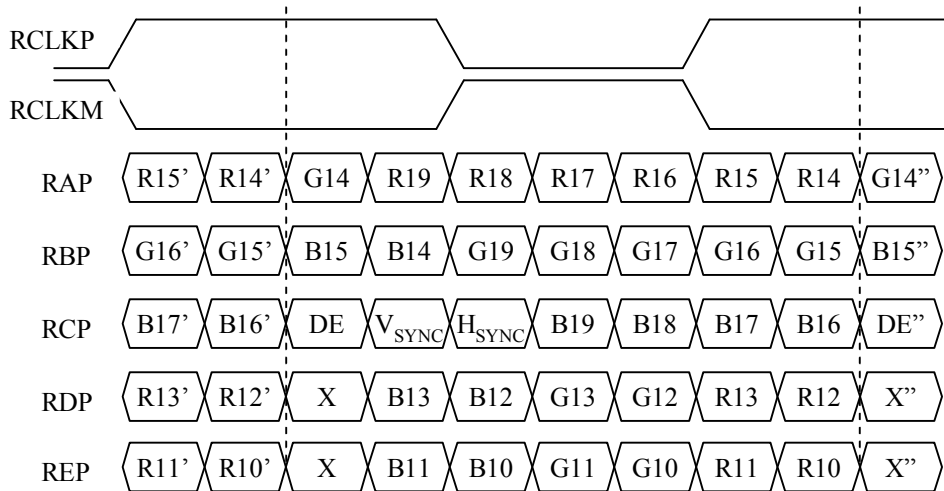

2) LVDS Select : "L" Data-Mapping (VESA format)

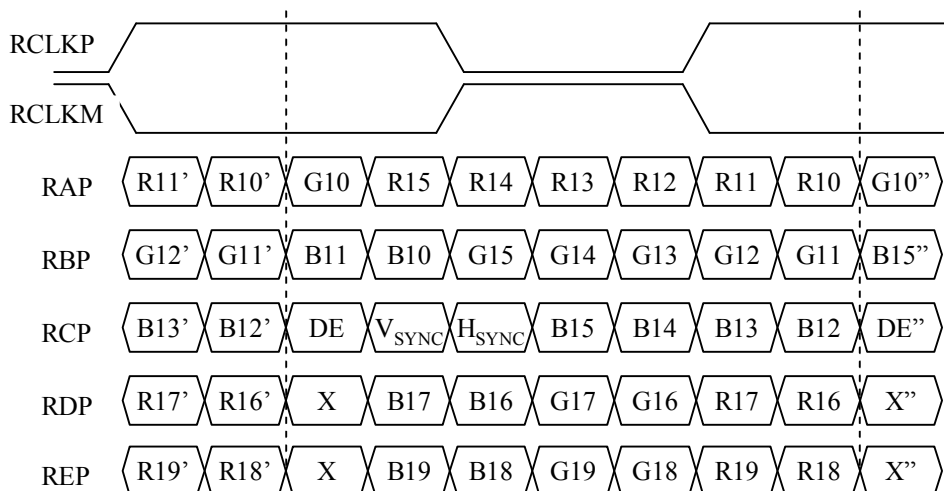

APPENDIX- IV

■ LVDS Data-Mapping Information (8 Bit)

1) LVDS Select : "H" Data-Mapping (JEIDA format)

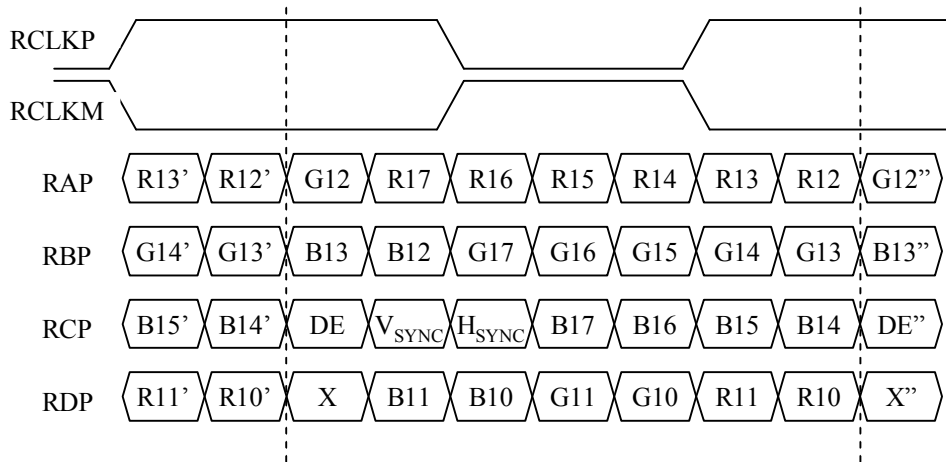

2) LVDS Select : "L" Data-Mapping (VESA format)

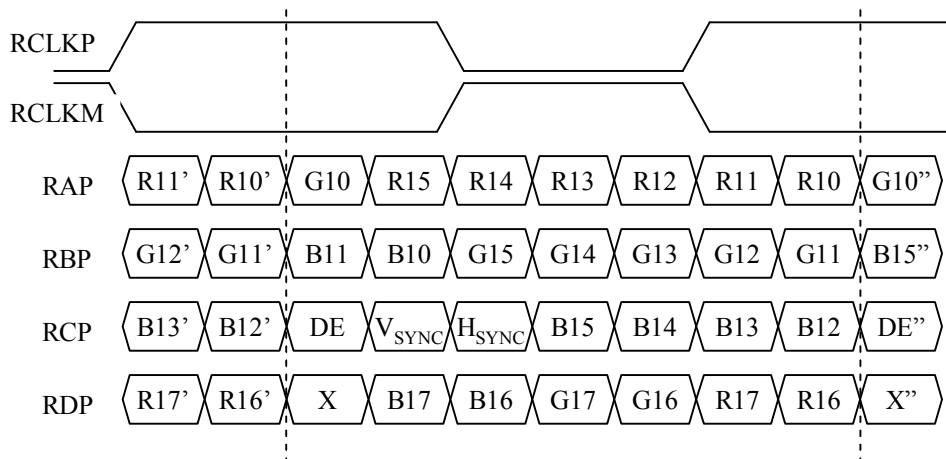

APPENDIX- V

■ Option Pin Circuit Block Diagram

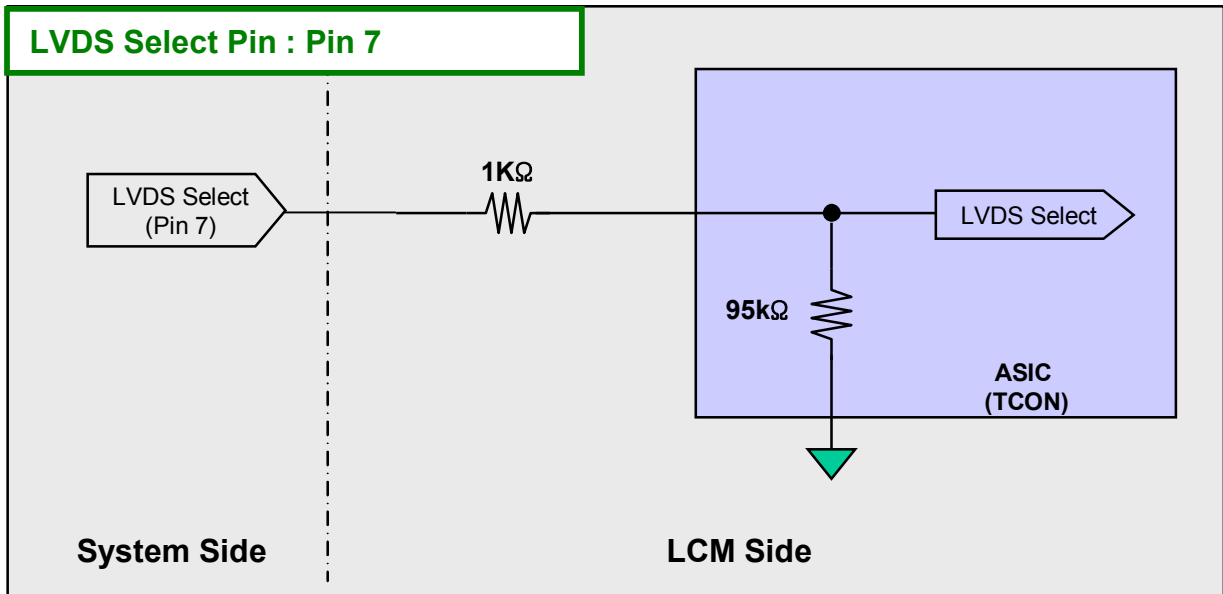
1) Circuit Block Diagram of **LVDS Format** Selection pin2) Circuit Block Diagram of **Bit** Selection pin