

Multi-Mode PWM Controller of Flyback with Integrated BNI/BNO and Protection

REV. 00

General Description

In order to enhance the efficiency performance, the LD5523/R/H/E integrates the multi-mode PWM controller, which consists of Quasi-Resonant (QR) PWM control for light load condition and Continue Conduction Mode (CCM) for heavy load condition. Moreover, the QR controller not only gains the system performance, but also brings the worse EMI capability, while the frequency swapping function of LD5523/R/H/E can reduce the EMI emission of SMPS and helps the power circuit designers to simply deal with EMI filter and saves several component and developing time.

The LD5523/R/H/E is implemented in SOT-26 package, and includes the comprehensive protection function, such as Over Load Protection (OLP), Over Voltage Protection (OVP), Output Short Circuit Protection (OSCP) and internal Over Temperature Protection (OTP). Furthermore, the programmable Brown-in/out Protection is built-in.

Features

- Secondary-side feedback control with quasi-resonant + CCM operation
- Low Startup Current (<math><1\mu\text{A}</math>)
- 0.285mA Ultra-low operating current at light load
- Current Mode Control with Cycle-by-Cycle Current Limit
- Green Mode Control
- UVLO (Under Voltage Lockout)
- LEB (Leading-Edge Blanking) on CS Pin
- VCC OVP (Over Voltage Protection)
- Adj. OVP (Over Voltage Protection) on FB pin.
- Adj. UVP (Under Voltage Protection) on FB pin.
- Adjustable Brown in/out on FB pin.
- OLP (Over Load Protection)
- External OTP (Over Temperature Protection) on CS Pin
- Internal OTP (Over Temperature Protection)
- SDSP (Secondary Diode Short Protection)
- Gate Source/Sink Capability: 350mA/-355mA @ output pin with 33nF capacitor.

Applications

- Switching AC/DC Adaptor

Typical Application

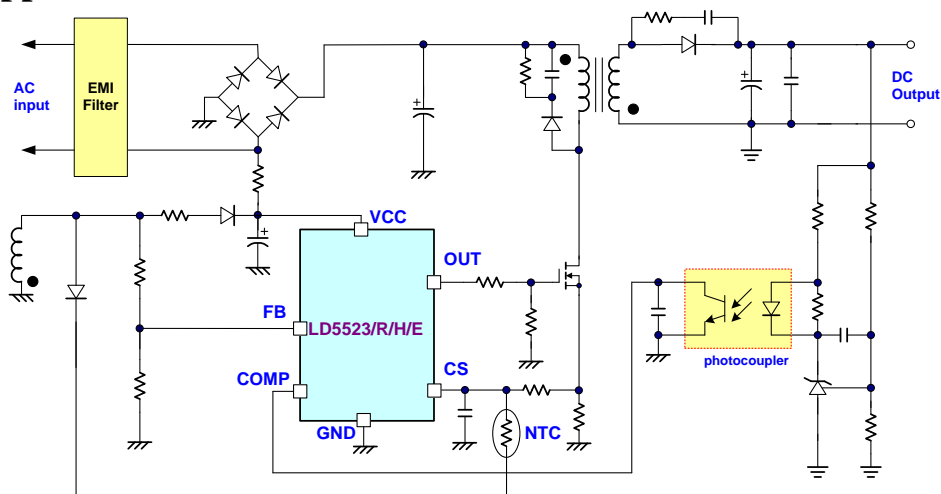

Pin Configuration

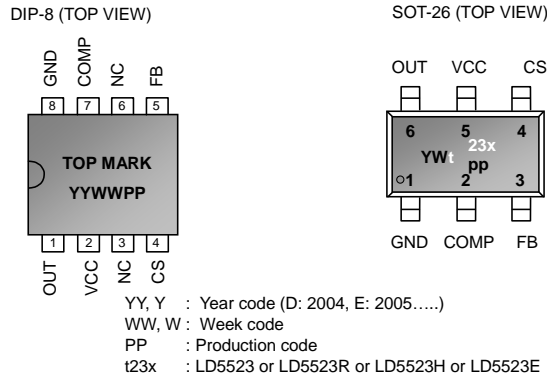

Ordering Information

Part number	Package	TOP MARK	Shipping
LD5523 GL	SOT-26 (Green Package)	YWt/23	3000 /tape & reel
LD5523 GN	DIP-8 (Green Package)	LD5523 GN	3600 /tube /Carton
LD5523R GL	SOT-26 (Green Package)	YWt/23R	3000 /tape & reel
LD5523R GN	DIP-8 (Green Package)	LD5523R GN	3600 /tube /Carton
LD5523H GL	SOT-26 (Green Package)	YWt/23H	3000 /tape & reel
LD5523H GN	DIP-8 (Green Package)	LD5523H GN	3600 /tube /Carton
LD5523E GL	SOT-26 (Green Package)	YWt/23E	3000 /tape & reel
LD5523E GN	DIP-8 (Green Package)	LD5523E GN	3600 /tube /Carton

The LD5523/R/H/E is RoHs compliant/ Green Packaged.

Protection Mode

Product Name	Switching Freq.	VCC_OVP	FB_OVP	OSCP	OLP	BNI/BNO	CS_OTP	Int. OTP
LD5523	65kHz	Latch	Latch	Auto recovery	Auto recovery	Auto recovery	Latch	Auto recovery
LD5523R	65kHz	Auto recovery	Auto recovery	Auto recovery	Auto recovery	Auto recovery	Latch	Auto recovery
LD5523H	65kHz	Latch	Latch	Latch	Latch	Auto recovery	Latch	Auto recovery
LD5523E	65kHz	Auto recovery	Auto recovery	Auto recovery	Auto recovery	Auto recovery	Auto recovery	Auto recovery

Pin Descriptions

NAME	PIN (SOT-26)	Pin (DIP-8)	FUNCTION
GND	1	8	Ground
COMP	2	7	Output of the error amplifier for voltage compensation
FB	3	5	Auxiliary voltage sense, brown in/out and Quasi Resonant detection
CS	4	4	Current sense pin, connect to sense the MOSFET current
VCC	5	2	Supply voltage pin
OUT	6	1	Gate drive output to drive the external MOSFET
NC		3	Unconnected Pin
NC		6	Unconnected Pin

Block Diagram

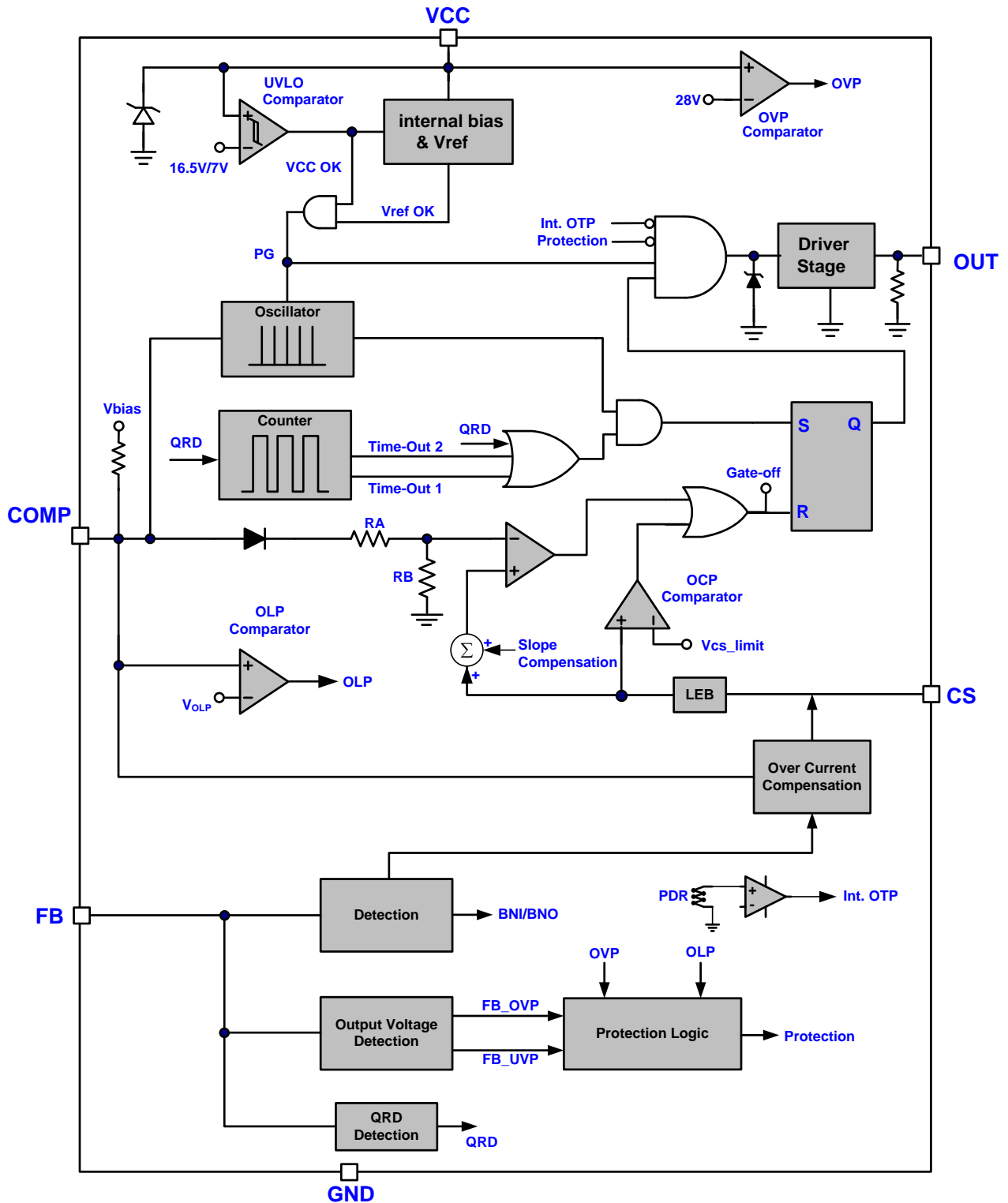

Absolute Maximum Ratings

Supply Voltage VCC,.....	-0.3V ~ 30V
COMP.....	-0.3V ~ 12V
FB, CS.....	-0.3V ~ 7V
OUT.....	-0.3V ~ VCC+0.3V
Maximum Junction Temperature.....	150°C
Storage Temperature Range.....	-65°C ~ 150°C
Package Thermal Resistance (SOT-26, θ_{JA}).....	200°C/W
Package Thermal Resistance (DIP-8, θ_{JA}).....	100°C/W
Power Dissipation (SOT-26, at Ambient Temperature = 85°C).....	200mW
Power Dissipation (DIP-8, at Ambient Temperature = 85°C).....	400mW
Lead temperature (Soldering, 10sec).....	260°C
ESD Voltage Protection, Human Body Model.....	2.5 KV
ESD Voltage Protection, Machine Model.....	250 V

Caution:

Stress exceeding Maximum Ratings may damage the device. Maximum Ratings are stress ratings only. Functional operation above the Recommended Operating Conditions is not implied. Extended exposure to stress above Recommended Operating Conditions may affect device reliability

Recommended Operating Conditions

Item	Min.	Max.	Unit
Operating Junction Temperature	-40	125	°C
Supply VCC Voltage	8.0	26.5	V
VCC Capacitor	3.3	10	μF
Start-up resistor Value (AC Side, Half Wave)	400K	2M	Ω
Comp Pin Capacitor (X7R type)	330	4700	pF
CS Pin Capacitor Value	47	470	pF

Note:

1. It's essential to connect VCC pin with a SMD ceramic capacitor (0.1μF ~ 0.47μF) to filter out the undesired switching noise for stable operation. This capacitor should be placed close to IC pin as possible
2. It's also essential to connect a capacitor to COMP to filter out the undesired switching noise for stable operation.
3. The small signal components should be placed close to IC pin as possible.

Electrical Characteristics

($T_A = +25^\circ\text{C}$ unless otherwise stated, $V_{CC}=15.0\text{V}$)

PARAMETER	CONDITIONS	SYMBOL	MIN	TYP	MAX	UNITS
Supply Voltage (VCC Pin)						
Startup Current		I_{CC_ST}			1	μA
Operating Current (with 1nF load on OUT pin)	$V_{COMP}=0\text{V}$, $OUT=1\text{nF}$	I_{CC_OP1}		0.285		mA
	$V_{COMP}=1.7\text{V}$, $OUT=1\text{nF}$ $I_{FB}=200\mu\text{A}$	I_{CC_OP2}		2.33		mA
	Auto current protection	I_{CC_OPA1}		0.6		mA
	Latch current protection	I_{CC_OPA2}	0.4	0.8	1.2	mA
	Brown in (Before the first pulse)/ Brown out	I_{CC_OPA3}	0.7	1.1	1.5	mA
Holding current	$V_{PDR} + 0.1\text{V}$	I_{HD}	30	40	50	μA
UVLO(OFF)		V_{CC_OFF}	6.5	7	7.5	V
UVLO(ON)		V_{CC_ON}	15.5	16.5	17.5	V
VCC OVP Level		V_{CC_OVP}	27	28	29	V
VCC OVP de-bounce time		T_{VCC_OVP}		8		Cycle
Latch-Off Release Voltage		V_{PDR}	4.1	4.8	5.5	V
Voltage Feedback (COMP Pin)						
Short Circuit Current	$V_{COMP}=0\text{V}$	I_{COMP}		0.116		mA
Open Loop Voltage	⁽¹⁾	V_{COMP_OPEN}		3.15		V
Min. OCP Compensation Current	$I_{FB} = 100\mu\text{A}$ ⁽¹⁾	I_{OCP_MIN}		75		μA
Max. OCP Compensation Current	$I_{FB} = 300\mu\text{A}$	I_{OCP_MAX}	200	225	250	μA
Current Sensing (CS Pin)						
Maximum Input Voltage		V_{CS_LIMIT}	0.48	0.5	0.52	V
Leading Edge Blanking Time		T_{LEB}		275		ns
Internal Slope Compensation	$*t_{on} > 3\mu\text{s}$ to D_{MAX} . (Linearly increase), ⁽¹⁾	V_{SLP_L}		165		mV
Delay to Output	⁽¹⁾	T_{PD}		80		ns
QRD (Quasi Resonant Detection, FB Pin)						
FB OVP Trip voltage Level		V_{FB_OVP}	3.3	3.5	3.7	V
FB OVP De-bounce Time		T_{FB_OVP}		8		Cycle
FB UVP Trip voltage Level	⁽¹⁾	V_{FB_UVP}		0.8		V
QRD Trip Level	⁽¹⁾	I_{QRD}		20		μA

PARAMETER	CONDITIONS	SYMBOL	MIN	TYP	MAX	UNITS
BNO Protection (FB Pin)						
Brown In Trip Level		I_{BNI}	90	95	100	μA
BNO Hysteresis		I_{BNO_HYS}	9	10	11	μA
Brown Out De-bounce Time	$V_{COMP}=1.7V$	T_{DB_BNO}		75		ms
OTP (Over Temperature, CS Pin)						
CS OTP Level	V_{CS_LIMIT}	V_{CS_OTP}	0.48	0.5	0.52	V
CS OTP de-bounce time	(1)	T_{CS_OTP}		5.4		ms
Oscillator for Switching Frequency						
CCM Frequency		F_{CCM}	60	65	70	kHz
Frequency Swapping	(1)	F_{SW_MOD}		± 8		%
Green Mode Frequency		F_{SW_GREEN}	21	24	27	kHz
Temp. Stability	(1)	F_{SW_TS}		3	5	%
Voltage Stability	$V_{CC} = 9V \sim 24V^{(1)}$	F_{SW_VS}			1	%
Maximum Duty	(1)	D_{MAX}		81		%
Gate Drive Output (OUT Pin)						
Output Low Level	$V_{CC} = 15V, I_o = 20mA^{(1)}$	V_{OL}			1	V
Output High Level	$V_{CC} = 15V, I_o = 20mA$	V_{OH}	9		14	V
Rising Time	$V_{CC} = 15V, C_L = 1000pF$	T_r		280		ns
Falling Time	$V_{CC} = 15V, C_L = 1000pF$	T_f		30		ns
Output High Clamp Level	$V_{CC} = 18V$	V_{O_CLAMP}		11.5		V
Soft Start						
Soft Start Time	V_{CS_OFF} from 0.2V to 0.5V ⁽¹⁾	T_{SS}		7		ms
SDSP (Secondary Diode Short Protection)						
SDSP CS Pin Level	Secondary diode short	V_{CS_SDSP}	1.0	1.3	1.6	V
De-bounce Cycle	(1)	T_{D_SDSP}		4		Cycle
Open Loop Protection						
OLP Trip Level		V_{OLP}		2.8		V
OLP delay time	After soft-start	T_{D_OLP}		88		ms
On Chip OTP (Over Temperature Protection)						
OTP Level	(1,2)	T_{INOTP}		140		$^{\circ}C$
OTP Hysteresis	(1,2)	T_{INOTP_HYS}		12		$^{\circ}C$

Notes:

1. Guaranteed by design.
2. The threshold temperature for enabling the output again and resetting the latch after OTP has been activated.

Typical Performance Characteristics

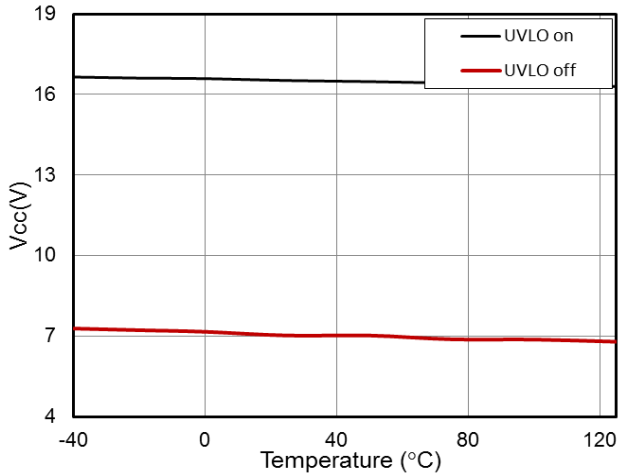

Fig. 1 UVLO Level vs. Temperature

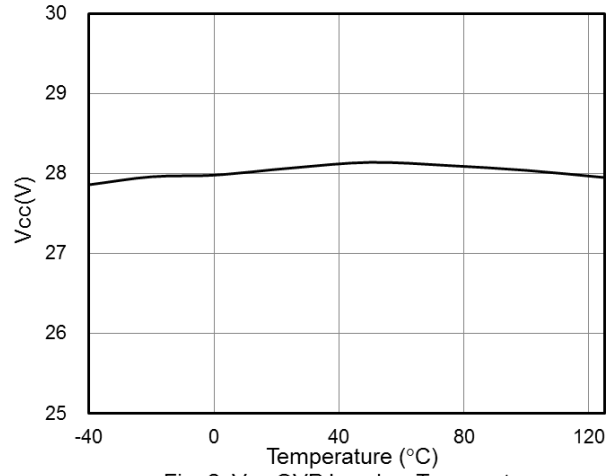

Fig. 2 Vcc OVP Level vs. Temperature

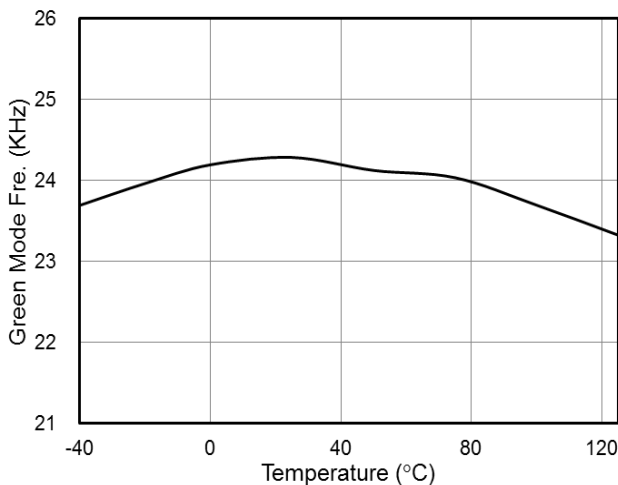

Fig. 3 Green Mode Fre. vs. Temperature

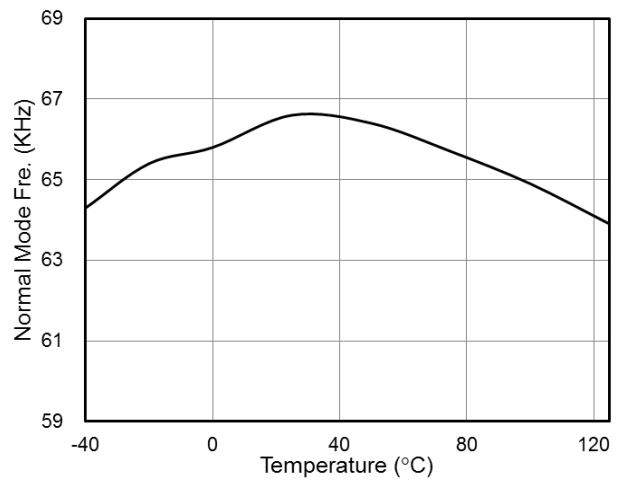

Fig. 4 Normal Mode Fre. vs. Temperature

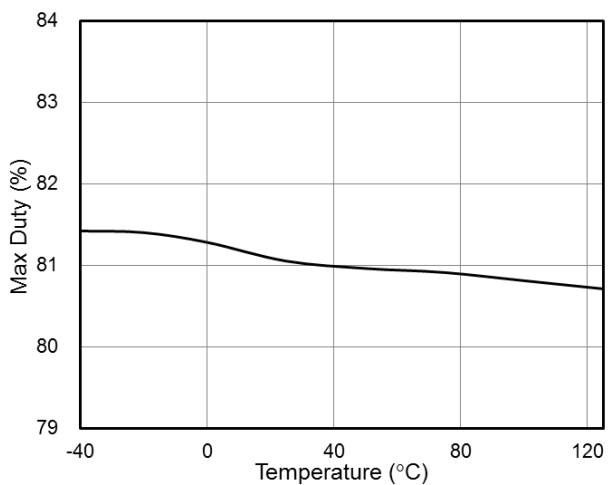

Fig. 5 Max Duty vs. Temperature

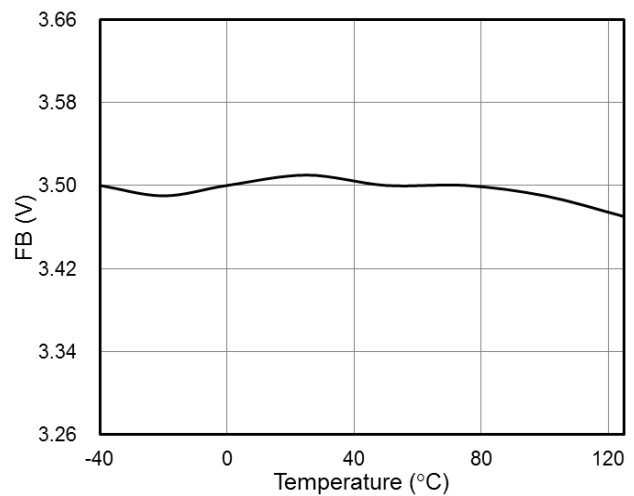

Fig. 6 FB OVP Level vs. Temperature

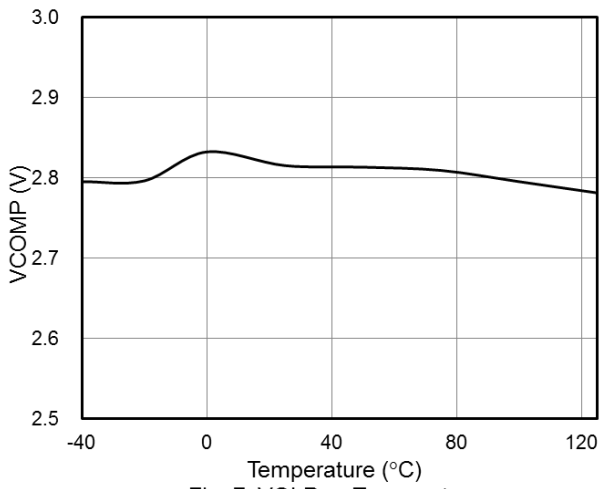

Fig. 7 VOLP vs. Temperature

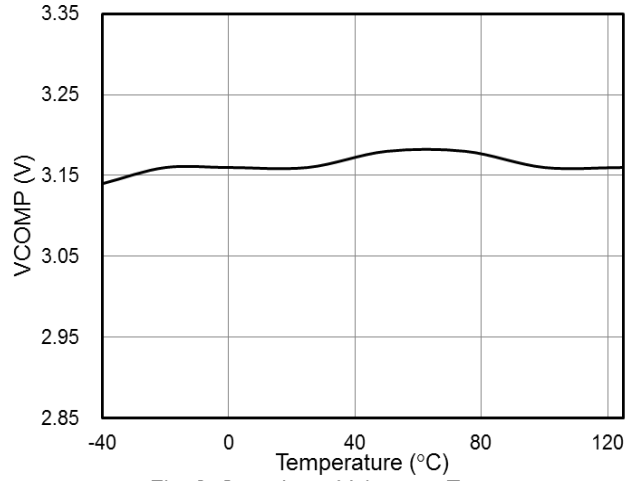

Fig. 8 Open Loop Voltage vs. Temperature

Application Information

Operation Overview

The LD5523/R/H/E is built in the multi-mode PWM controller, in which operates a constant frequency to achieve the CCM as heavy load. For demanding higher power efficiency and power-saving in light load condition, the LD5523/R/H/E implements QR function to allow the valley switching and accomplish zero voltage switching (ZVS). Under different load conditions, LD5523/R/H/E provides the different solutions for achieving higher efficiency and performance.

Under Voltage Lockout (UVLO)

An UVLO comparator is implemented in it to detect the voltage on the VCC pin. It would assure the supply voltage enough to turn on the LD5523/R/H/E PWM controllers and further to drive the power MOSFET. As shown in Fig. 9, a hysteresis is built in to prevent the shutdown from the voltage dip during startup. The turn-on and turn-off threshold level are set at 16.5V and 7V, respectively.

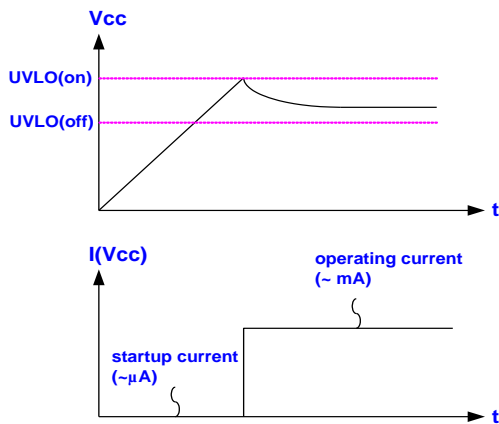

Fig. 9

Startup Current and Startup Circuit

The typical startup circuit to generate the LD5523/R/H/E VCC is shown in Fig. 10. During the startup transient, the VCC is lower than the UVLO threshold thus there is no

gate pulse produced from LD5523/R/H/E to drive power MOSFET. Therefore, the current through R1 will provide the startup current and to charge the capacitor C1. Whenever the VCC voltage is high enough to turn on the LD5523/R/H/E and further to deliver the gate drive signal, the supply current is provided from the auxiliary winding of the transformer.

Lower startup current requirement on the PWM controller will help to increase the value of R1 and then reduce the power consumption on R1. By using CMOS process and the special circuit design, the maximum startup current of LD5523/R/H/E is only 1µA. If a higher resistance value of R1 is chosen, it usually takes more time to start up. To select the value of R1 and C1 carefully will optimize the power consumption and startup time.

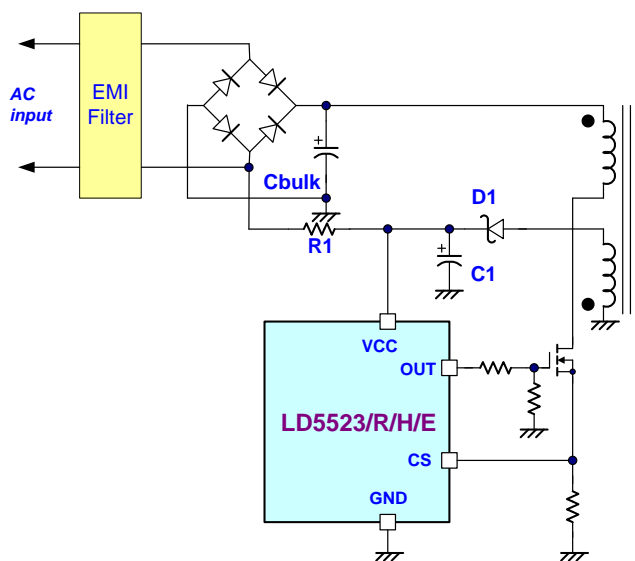

Fig. 10

QR Mode Detection

The transformer will be demagnetized after the main power MOSFET turns off. A quasi resonant signal will be detected from auxiliary winding by FB pin through the external resistor.

As soon as the current of the secondary side diode is down to zero during MOSFET-off period, the transformer's core is demagnetized completely. V_{DS} of MOSFET will resonate in discontinuous current mode. The resonance frequency (F_{QR}) will be obtained as below.

$$F_{QR} = \frac{1}{2\pi\sqrt{L_m * C_R}} \text{ (HZ)}$$

L_M = Inductance of primary winding

C_R = Resonance equivalent parasitic capacitance

If V_{DS} voltage falls to resonant valley level from max plateau value, the QRD comparator will be tripped while FB pin current is close to $20\mu A$.

However, the QR detection will be influenced by propagation delay. If inductance of primary winding is less than $500\mu H$, there is barb in V_{ds} (as shown in Fig. 11).

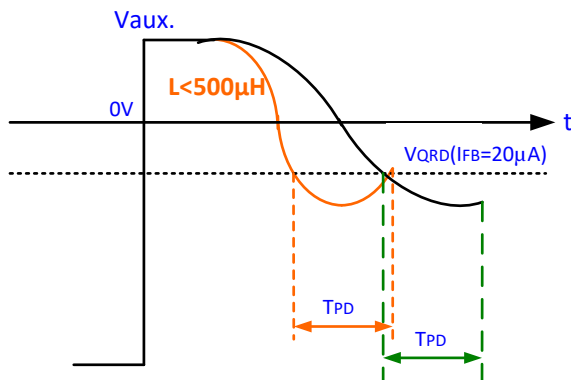

Fig. 11

Voltage Feedback Loop

The voltage feedback signal is provided from the TL431 at the secondary side through the photo-coupler to the COMP pin of the LD5523/R/H/E. Similar to UC3842, the LD5523/R/H/E would without voltage offset to feed the voltage divider at the ratio of R_A and R_B , that is,

$$V_{-(PWM_{COMPARATOR})} = \frac{R_B}{R_A + R_B} \times V_{COMP}$$

A pull-high resistor is embedded internally and therefore no external one is required.

The LD5523/R/H/E integrates the multi-mode PWM controller, and for enhance the light load efficiency, the

comp pin value corresponding to the frequency is as shown in Fig. 12.

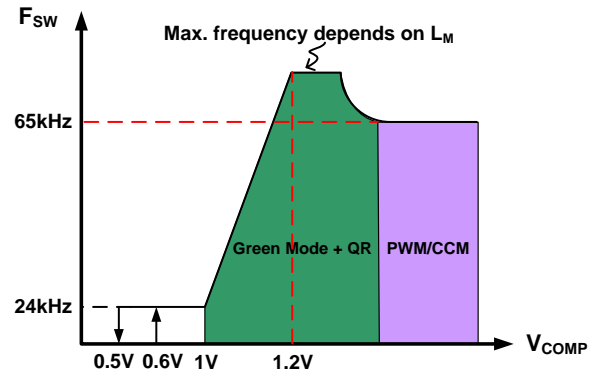

Fig. 12

Current Sensing, Leading Edge Blanking

The typical current mode of PWM controller feedbacks both current signal and voltage signal to close the control loop and achieve regulation. The LD5523/R/H/E detect the primary MOSFET current from the CS pin, which is not only for the peak current mode control but also for the pulse-by-pulse current limit. The maximum voltage threshold of the current sensing pin sets at $0.5V$. From above, the MOSFET peak current can be obtained from below.

$$I_{PEAK(MAX)} = \frac{0.5V}{R_{CS}}$$

A $275nS$ leading-edge blanking (LEB) time is included in the input of CS pin to prevent the false-trigger from the current spike. In the low power application, if the total pulse width of the turn-on spike is less than $275nS$ and the negative spike on the CS pin doesn't exceed $-0.3V$, it could remote the R-C filter (as shown in the Fig. 13).

However, the total pulse width of the turn-on spike is decided by the output power, circuit design and PCB layout. It is strongly recommended to adopt a smaller R-C filter (as shown in Fig. 14) for higher power application to avoid the CS pin being damaged by the negative turn-on spike.

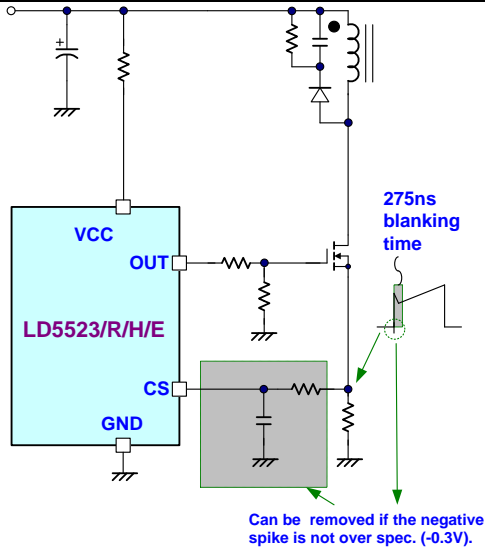

Fig. 13

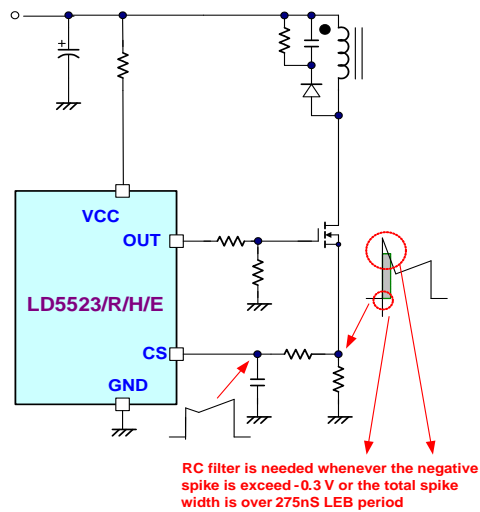

Fig. 14

Output Stage and Maximum Duty

An output stage of a CMOS buffer, with typical 380mA driving capability, is incorporated to drive a power MOSFET directly. And the maximum duty of LD5523/R/H/E is limited to 81% avoid detecting QR fail.

Over Voltage Protection on VCC pin (VCC OVP) – Auto Recovery for LD5523E

According to the QR operation principle, the switching frequency is inversely proportional to the output power. Therefore, as the output power increases, the switching

frequency can become rather low without limiting. The CCM switching frequency of LD5523/R/H/E is clamped at 65 kHz internally to provide the optimized operations by considering the EMI performance, thermal treatment, component sizes and transformer design.

Over Voltage Protection on VCC pin (VCC OVP) – Auto Recovery for LD5523E

The V_{GS} ratings of the nowadays power MOSFETs are often limited up to max. 28V. To prevent the V_{GS} from the fault condition, LD5523E is implemented with an OVP function on VCC. Whenever the VCC voltage is higher than the OVP threshold voltage, the output gate drive circuit will be shutdown simultaneously thus to stop the switching of the power MOSFET until the next UVLO(ON).

The VCC OVP function in LD5523E is an auto-recovery type protection. The Fig. 15 shows its operation.

On the other hand, if the OVP condition is removed, the VCC level will get back to normal level and the output will automatically return to the normal operation.

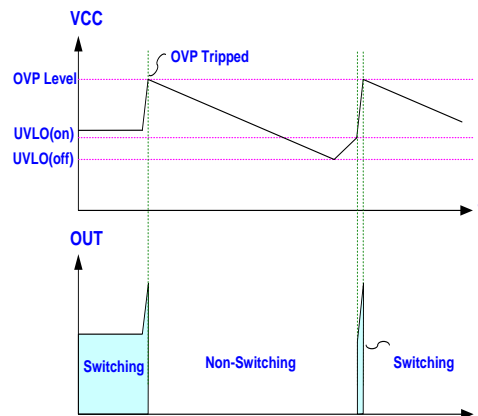

Fig. 15

Over Load Protection (OLP) – Auto Recovery for LD5523E

To protect the circuit from damage due to over-load condition and short or open-loop condition, the LD5523E is implemented with smart OLP function. It also features auto-recovery function, see Fig. 16 for the waveform. In

case of fault condition, the feedback system will force the voltage loop toward the saturation and then pull the voltage high on COMP pin (VCOMP). When the V_{COMP} ramps up to the OLP threshold of 2.8V and continues over OLP delay time, the protection will be activated and then turn off the gate output to stop the switching of power circuit.

With the protection mechanism, the average input power will be minimized to remain the component temperature and stress within the safe operating area.

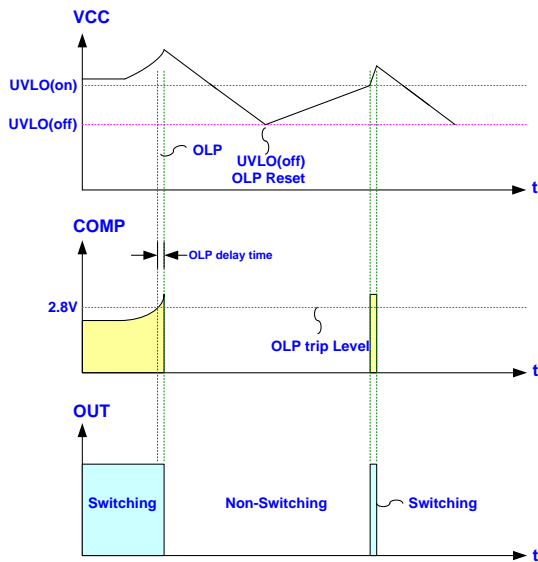

Fig. 16

Adjustable Over Current Compensation on FB Pin

For compensating the differential input current from high/low line conditions on current sensing resistor, LD5523/R/H/E mirrors a compensation current I_{OCP} from I_{FB} to CS pin. The relationship of compensation current I_{OCP} and I_{FB} is expressed by following equation and shown in Fig. 17.

$$I_{OCP} = K \times I_{FB}$$

, where $K = 0.75$

K is the mirror current ratio of FB pin, and the I_{OCP} follows to the input voltage. When the V_{COMP} ramps up to the I_{OCP}

threshold of 1.4V, the compensation current is added. And the V_{COMP} hysteresis of I_{OCP} is 0.15V.

The compensation current I_{OCP} supplies an offset voltage by external resistor R_{OCP}, which is series between the current sensing resistor R_S and CS pin. By selecting a proper value of the resistor R_{OCP} in series with the CS pin, the amount of compensation can be adjusted.

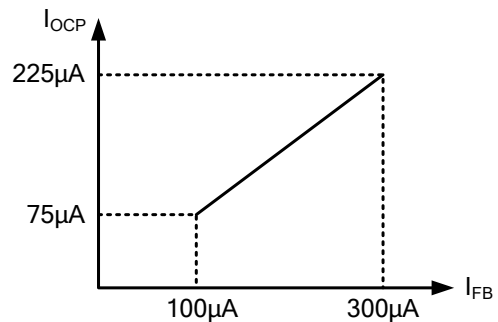

Fig. 17

Brown-In/ Brown-Out Protection (BNI/BNO) – Auto Recovery

The LD5523/R/H/E integrate the brown in, brownout protection and valley detection into FB pin. The auxiliary voltage reflects a proportional bulk voltage during the on time. Fix the internal current at the BNI and BNO, the BNI level could be set by modulating the FB divided resistors and auxiliary voltage, as shown in Fig. 18. For preventing the abnormal condition of line voltage to causing damage, BNO function is implemented, while turns off the gate signal after de-bounce time 75ms as BNO occurring, as shown in Fig. 19. The relationship of input voltage and BNI/BNO is expressed in following equation.

$$V_{DC_BNI} = \frac{N_P}{N_a} \cdot I_{BNI} \cdot R_1$$

$$V_{DC_BNO} = \frac{N_P}{N_a} \cdot I_{BNO} \cdot R_1$$

,where

V_{DC_BNI} is predicted BNI DC value of input voltage

V_{DC_BNO} is predicted BNO DC value of input voltage

I_{BNI} is BNI trip current.

I_{BNO} is BNO trip current.

N_p is turns ration of primary-side winding

N_a is turns ration of auxiliary winding

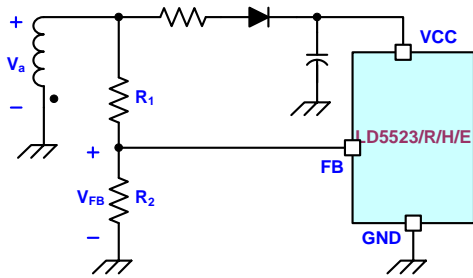

Fig. 18

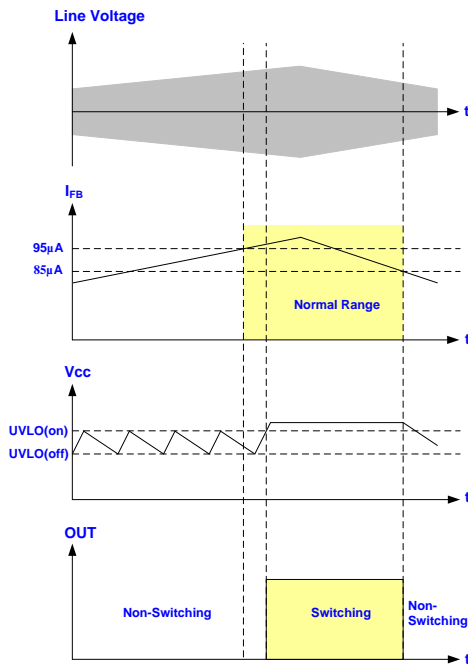

Fig. 19

Over Voltage Protection on FB pin (FB OVP) – Auto Recovery for LD5523E

An output overvoltage protection is implemented in the LD5523E. The auxiliary winding voltage can be reflected from secondary winding, in which the FB pin voltage is proportional to output voltage during the gate off time. OVP is worked by sensing the auxiliary voltage via the divided resistors R2, refereeing to Fig. 18. The equation of FB OVP is shown as follows.

$$R_2 = \frac{R_1 \cdot V_{FB_OVP}}{V_a - V_{FB_OVP}}$$

$$V_a = \frac{N_a}{N_s} (V_o + V_F)$$

V_{FB_OVP} is the FB pin OVP trip voltage level. V_a is the auxiliary winding voltage which reflects from the forward voltage V_F of Schottky diode and output voltage V_o . N_s is turns ration of secondary-side winding.

If V_{FB} overs the FB OVP trip level, the internal counter starts counting 8 cycles, and then LD5523E goes to auto-recovery protection mode till the FB OVP status is defused

Output Short Circuit Protection (OSCP) – Auto Recovery for LD5523E

The OSCP function can prevent the damage from output short circuit. Once the output is shorted, V_o and V_{CC} drop immediately, which always reflects the auxiliary winding during the gate off region. Therefore, as V_{FB} is lower than 0.8V during gate off region, then the FB_UVP is triggered, and skips one cycle. According to the close loop control, COMP voltage will pull high in the meanwhile. If the VCOMP pulls higher than 2.8V over 13 ms and V_{cc} drops below 9.6V. At this time, the OSCP protection will be triggered and turn off the gate driving.

Over Temperature Protection on CS pin (CS OTP)- Auto Recovery for LD5523E

LD5523E is implemented over temperature protection on CS pin which senses voltage to determine NTC status during gate off region. As V_{CS} is greater than 0.5V and continues for 5.4ms, CS_OTP is triggered, than LD5523E is in auto recovery mode till the temperature drops to setting work condition.

Oscillator and Switching Frequency

The LD5523/R/H/E is implemented with Frequency Swapping function which helps the power supply

designers to both optimize EMI performance and lower system cost.

Secondary Diode Short Protection (SDSP) – Auto Recovery for LD5523E

The method that the LD5523/R/H/E judges the logic of SDSP is described briefly as follows. When VCS is higher than 1.3V, it will reduce the frequency first, even the $T_{on} < LEB + T_{PD}$. When the count is up to 4 times, its gate will be turned-off, shown as Fig. 20.

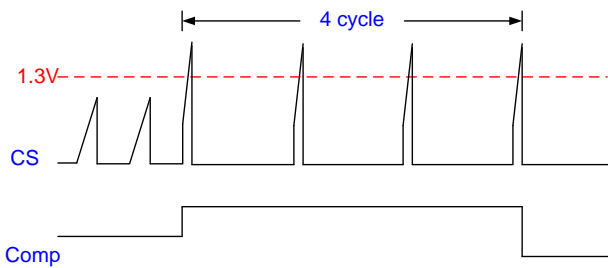

Fig. 20

Green Mode Operation

By using the green-mode control, the switching frequency can be reduced under the light load condition. This feature helps to improve the efficiency in light load conditions. The green-mode control is Leadtrend Technology's own property.

Fault Protection

There are several critical protections integrated in the LD5523/R/H/E to prevent from damage to the power

supply. Those damages usually come from open or short conditions on the pins of LD5523/R/H/E.

In case under such conditions listed below, the gate output will turn off immediately to protect the power circuit.

1. CS pin floating
2. COMP pin floating

Package Information

SOT-26

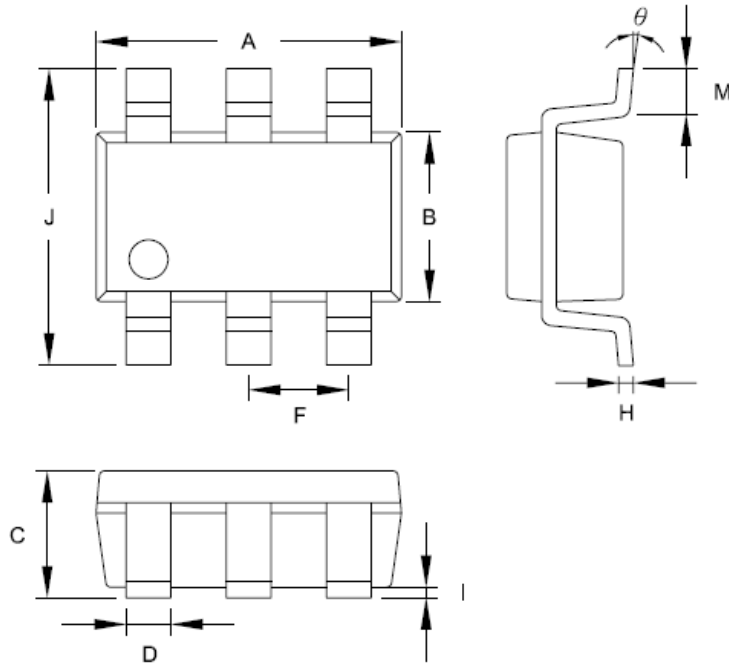

Symbol	Dimension in Millimeters		Dimensions in Inches	
	Min	Max	Min	Max
A	2.692	3.099	0.106	0.122
B	1.397	1.803	0.055	0.071
C	-----	1.450	-----	0.057
D	0.300	0.500	0.012	0.020
F	0.95 TYP		0.037 TYP	
H	0.080	0.254	0.003	0.010
I	0.050	0.150	0.002	0.006
J	2.600	3.000	0.102	0.118
M	0.300	0.600	0.012	0.024
θ	0°	10°	0°	10°

Package Information

DIP-8

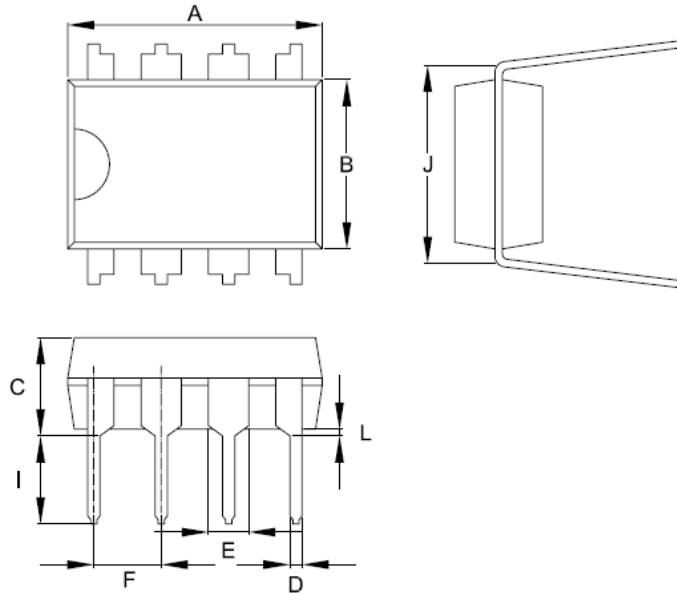

Symbol	Dimension in Millimeters		Dimensions in Inches	
	Min	Max	Min	Max
A	9.017	10.160	0.355	0.400
B	6.096	7.112	0.240	0.280
C	-----	5.334	-----	0.210
D	0.356	0.584	0.014	0.023
E	1.143	1.778	0.045	0.070
F	2.337	2.743	0.092	0.108
I	2.921	3.556	0.115	0.140
J	7.366	8.255	0.29	0.325
L	0.381	-----	0.015	-----

Important Notice

Leadtrend Technology Corp. reserves the right to make changes or corrections to its products at any time without notice. Customers should verify the datasheets are current and complete before placing order.

Revision History

REV.	Date	Change Notice
00	10/14/2016	Original Specification.