

Green-Mode PWM Controller with Frequency Swapping and Integrated Protections

REV: 01

General Description

The LD5535A has several built-in functions, protection and EMI-improved solution in a tiny package. It uses less components counts or circuit space. It is especially ideal for those total solutions of low cost.

The implemented functions include low startup current, green-mode power-saving operation, leading-edge blanking of the current sensing and internal slope compensation. It also features more protections like OLP (Over Load Protection) and OVP (Over Voltage Protection) to prevent circuit from being damaged under abnormal conditions.

Furthermore, the Frequency Swapping function reduces the noise level and thus helps the power circuit designers to easily deal with the EMI filter design by taking minimum amount of component cost and developmental time.

Features

- High-Voltage CMOS Process with Excellent ESD protection
- Very Low Startup Current (<3 μ A)
- Current Mode Control
- Green Mode Control
- UVLO (Under Voltage Lockout)
- LEB (Leading-Edge Blanking) on CS Pin
- Internal Frequency Swapping, Slope Compensation
- OVP (Over Voltage Protection) on VCC and CS Pin
- Adjustment OCP(Over Current Protection) on CS Pin
- OTP (Over Temperature Protection) through a NTC
- OLP (Over Load Protection)
- OSCP (Output Short Circuit Protection)
- 250mA/500mA Driving Capability

Applications

- Switching AC/DC Adaptor and Battery Charger
- Open Frame Switching Power Supply

Typical Application

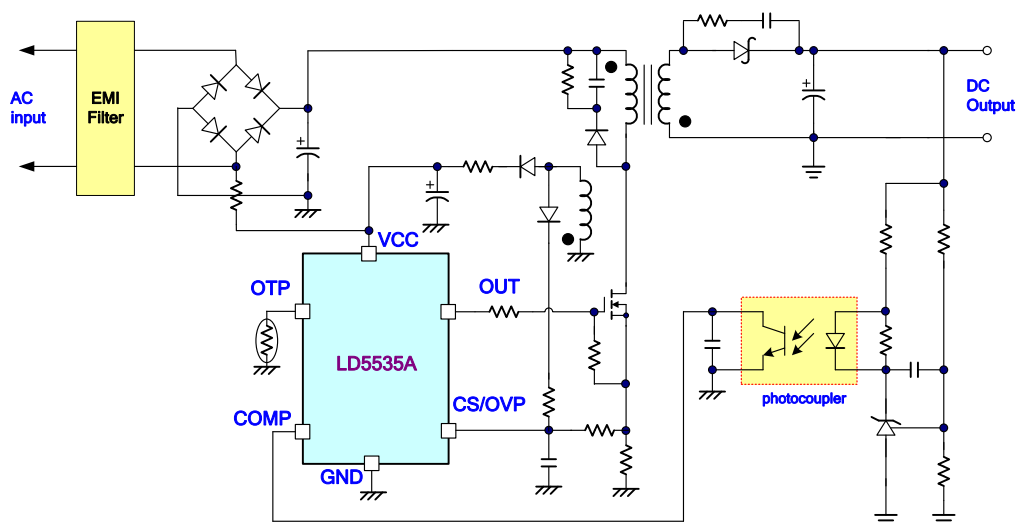

Pin Configuration

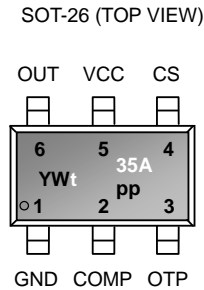

YY, Y : Year code (D: 2004, E: 2005.....)
 WW, W : Week code
 PP : Production code
 t35A : LD5535A

Ordering Information

Part number	Package	Top Mark	Shipping
LD5535A GL	SOT-26	YWt/35A	3000 /tape & reel

The LD5535A is ROHS compliant / Green Packaged

Protection Mode

Switching Freq.	OLP/SCP	VCC OVP	CS OVP	OSCP	OTP Pin
65kHz	Auto recovery	Latch	Latch	Auto-restart /8cycle	Latch

Pin Descriptions

SOT-26	NAME	FUNCTION
1	GND	Ground
2	COMP	Voltage feedback pin (same as the COMP pin in UC384X). Connect a photo-coupler to close the control loop and achieve the regulation.
3	OTP	Pull this pin below 0.95V to shut down the controller into latch mode until the AC resumes power-on. Connecting this pin to ground with NTC will achieve OTP protection. Let this pin float or connect a 100kΩ resistor to disable the latch protection.
4	CS	Current sense pin, connect it to sense the MOSFET current.
5	VCC	Supply voltage pin
6	OUT	Gate drive output to drive the external MOSFET

Block Diagram

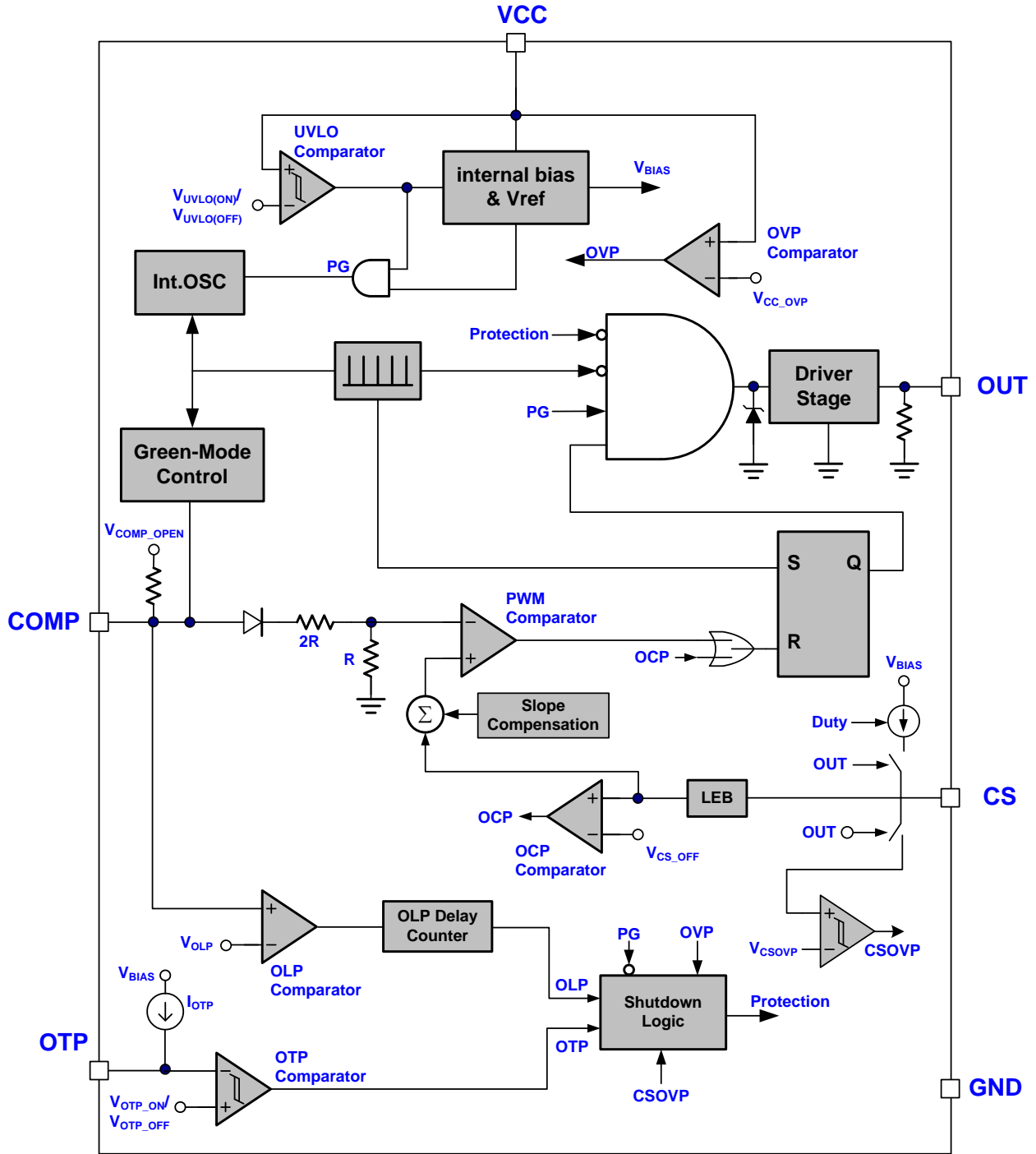

Absolute Maximum Ratings

Supply Voltage VCC.....	-0.3V ~ 30V
COMP, CS, OTP.....	-0.3V ~ 6V
OUT.....	-0.3V ~ VCC+0.3V
Maximum Junction Temperature.....	150°C
Storage Temperature Range.....	-65°C ~ 150°C
Package Thermal Resistance (SOT-26, θ_{JA}).....	200°C/W
Power Dissipation (SOT-26, at Ambient Temperature = 85°C).....	200mW
Lead temperature (Soldering, 10sec).....	260°C
ESD Voltage Protection, Human Body Model.....	2.5 KV
ESD Voltage Protection, Machine Model.....	250 V

Caution:

Stress exceeding Maximum Ratings may damage the device. Maximum Ratings are stress ratings only. Functional operation above the Recommended Operating Conditions is not implied. Extended exposure to stress above Recommended Operating Conditions may affect device reliability

Recommended Operating Conditions

Item	Min.	Max.	Unit
Operating Junction Temperature	-40	125	°C
Supply VCC Voltage	8.5	26.5	V
VCC Capacitor	3.3	10	μF
Start-up resistor Value (AC Side, Half Wave)	540K	2.2M	Ω
COMP Pin Capacitor	1	10	nF
CS Pin Capacitor Value	47	390	pF

Note:

1. It's essential to connect VCC pin with a SMD ceramic capacitor (0.1μF ~ 0.47μF) to filter out the undesired switching noise for stable operation. This capacitor should be placed close to IC pin as possible
2. It's also essential to connect a capacitor to COMP to filter out the undesired switching noise for stable operation.
3. The small signal components should be placed close to IC pin as possible.

Electrical Characteristics

($T_A = +25^\circ\text{C}$ unless otherwise stated, $V_{CC}=15.0\text{V}$)

PARAMETER	CONDITIONS	SYM.	MIN	TYP	MAX	UNITS
Supply Voltage (VCC Pin)						
Startup Current	$V_{CC} < UVLO(ON)$	I_{CC_ST}			3	μA
Operating Current (with 1nF load on OUT pin)	$V_{COMP}=2\text{V}$	I_{CC_OP1}		1.95		mA
	$V_{COMP}=0\text{V}$	I_{CC_OP2}		0.35		mA
	OLP/ Auto	I_{CC_OPA}		600		μA
	OTP Pin Tripped / OVP Tripped / Latch $V_{CC}=10\text{V}$	I_{CC_OPL1}		410		μA
	OTP Pin Tripped / OVP Tripped / Latch $V_{CC}=5\text{V}$	I_{CC_OPL2}		40		μA
Latch-Off Release Voltage		V_{CCPDR}	3.6	4.5	5.2	V
UVLO(OFF)	OUT OFF	V_{CCOFF}	6.5	7.5	8.0	V
UVLO(ON)		V_{CCON}	14.5	16	17.5	V
VCC OVP Level		V_{CCOVP}		28.5		V
Voltage Feedback (Comp Pin)						
Short Circuit Current	$V_{COMP}=0\text{V}$	I_{COMP}		0.2		mA
Open Loop Voltage	COMP pin open	V_{COMP_OPEN}		3		V
Normal Mode Threshold VCOMP		V_N		1.2		V
Green Mode Threshold VCOMP	*	V_G		1		V
Zero Duty Threshold VCOMP		V_{ZDC}		0.6		V
Zero Duty Hysteresis		V_{ZDCH}		100		mV
IOCP Threshold VCOMP	Duty $\leq 20\%$	V_{COMP_OCP}		1.5		V
Current Sensing (CS pin)						
Maximum Input Voltage, V_{CS_OFF}		V_{CS_MAX}	0.8	0.85	0.9	V
Max. OCP Compensation Current, I_{OCP}		I_{OCP}	220	240	260	μA
Leading Edge Blanking Time, LEB		T_{LEB}		230		ns
Internal Slope Compensation	*0% to D_{MAX} . (Linearly increase)	V_{SLP_L}		300		mV
Input impedance	*	Z_{CS}	1			$M\Omega$
Delay to Output	*	T_{PD}		100		ns
Soft Start Duration	*	T_{SS}		7		ms

PARAMETER	CONDITIONS	SYM.	MIN	TYP	MAX	UNITS
Oscillator for Switching Frequency						
Frequency, FREQ		F_{SW}	60	65	70	kHz
Green Mode Frequency, FREQG		F_{SW_GREEN}		23		kHz
Frequency Swapping	$V_{COMP} > 2V$	F_{SW_MOD}		± 6		%
Temp. Stability	(-20°C ~85°C)*	F_{SW_TS}	0	5		%
Voltage Stability	(VCC=11V-25V)*	F_{SW_VS}	0	1		%
Gate Drive Output (OUT Pin)						
Output Low Level	VCC=15V, Io=20mA	V_{OL}			1	V
Output High Level	VCC=15V, Io=20mA	V_{OH}	8		15	V
Output High Clamp Level	VCC=20V	V_{O_CLAMP}		12		V
Rising Time	Load Capacitance=1000pF*	T_r		150	250	ns
Falling Time	Load Capacitance=1000pF*	T_f		50	75	ns
Max. Duty		MXD		85		%
OLP (Over Load Protection)						
OLP Trip Level		V_{OLP}		2.6		V
OLP Delay Time at start-up	*	T_{D_OLP}		420		ms
Over Voltage Protection (CS/OVP pin)						
OVP Trip Current Level		V_{CSOVP}	0.28	0.3	0.32	V
De-bounce Cycle	*	T_{D_CSOVP}		8		Cycle
OTP Pin Latch Protection (OTP Pin)						
OTP Pin Source Current		I_{OTP}	90	100	110	μA
OTP Turn-On Trip Level		V_{OTP_ON}		1.05		V
OTP Turn-Off Trip Level		V_{OTP_OFF}		0.95		V
OTP pin de-bounce time	$V_{COMP} > 2V$	T_{D_OTP}		500		μs
Internal OTP Protection						
OTP Level	*	T_{UP_OTP}		140		°C
OTP Hysteresis	*	T_{INOTP_HYS}		20		°C

*: Guaranteed by design.

Typical Performance Characteristics

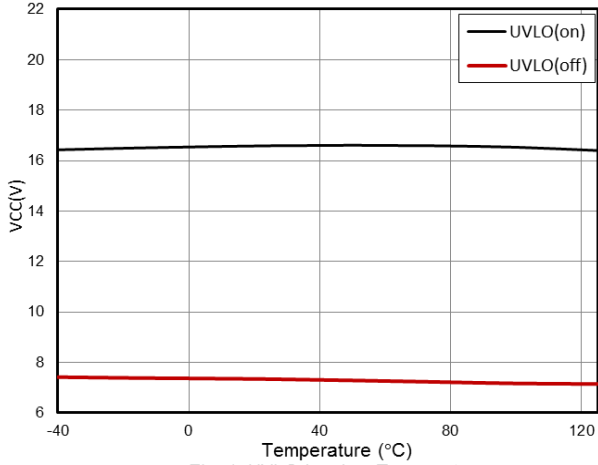

Fig. 1 UVLO level vs. Temperature

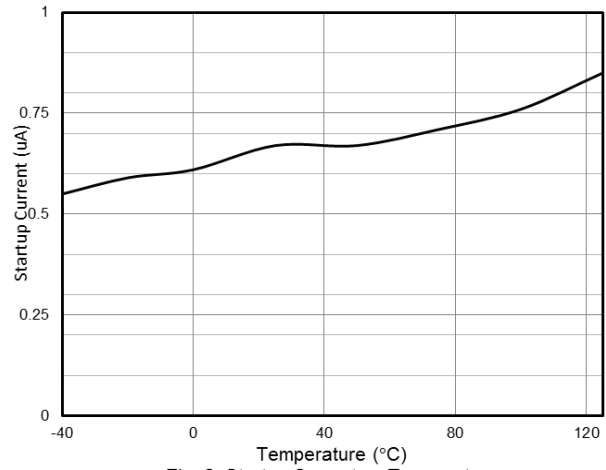

Fig. 2 Startup Current vs. Temperature

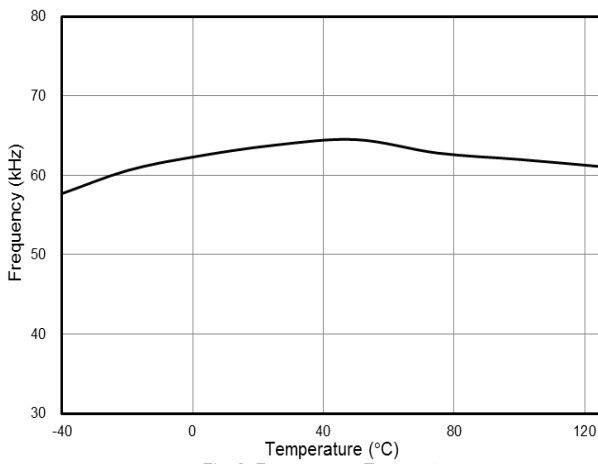

Fig. 3 Frequency vs. Temperature

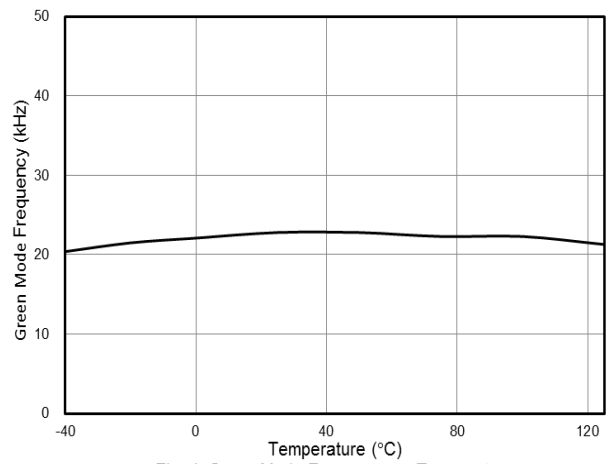

Fig. 4 Green Mode Frequency vs. Temperature

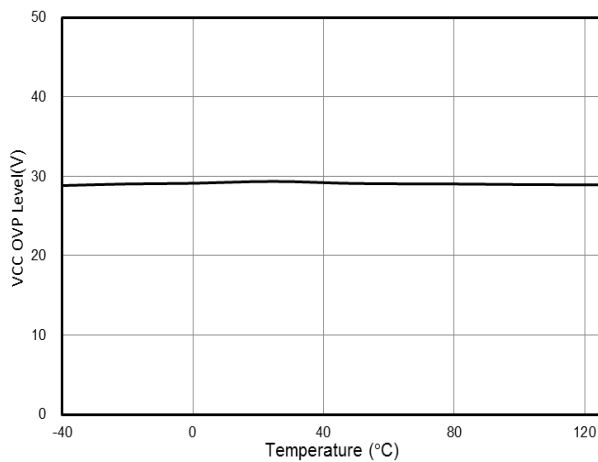

Fig. 5 VCC OVP Level vs. Temperature

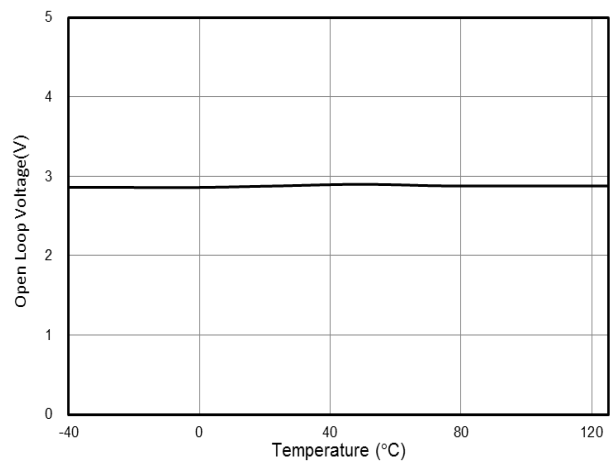

Fig. 6 Open Loop Voltage vs. Temperature

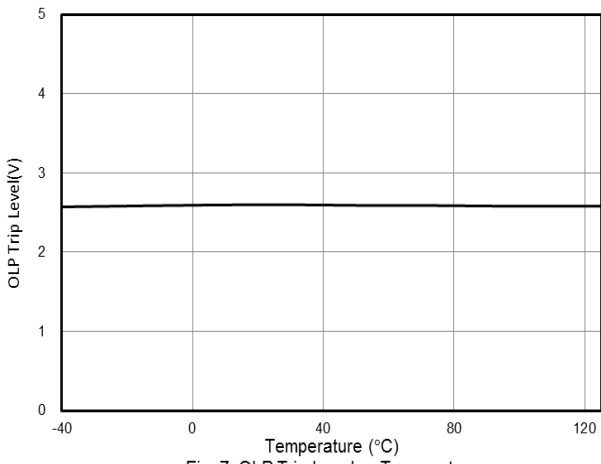

Fig. 7 OLP Trip Level vs. Temperature

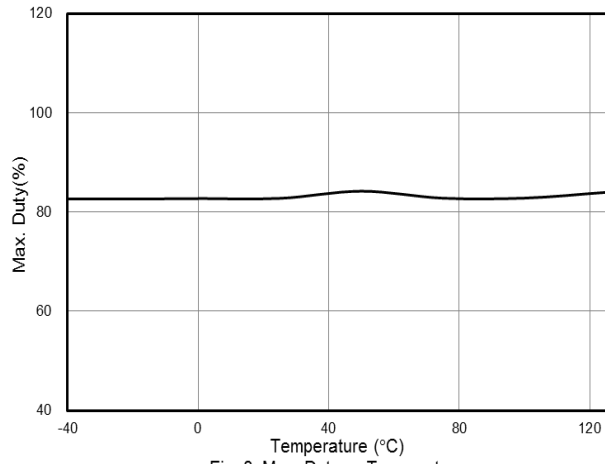

Fig. 8 Max. Duty vs. Temperature

Application Information

Operation Overview

The LD5535A meets the green-power requirement and is intended for the use in those modern switching power suppliers and adaptors which demand higher power efficiency and power-saving. It integrated more functions to reduce the external components counts and the size. Its major features are described as below.

Under Voltage Lockout (UVLO)

An UVLO comparator is implemented in it to detect the voltage on the VCC pin. It would assure the supply voltage enough to turn on the LD5535A PWM controller and further to drive the power MOSFET. As shown in Fig. 9, a hysteresis is built in to prevent the shutdown from the voltage dip during startup.

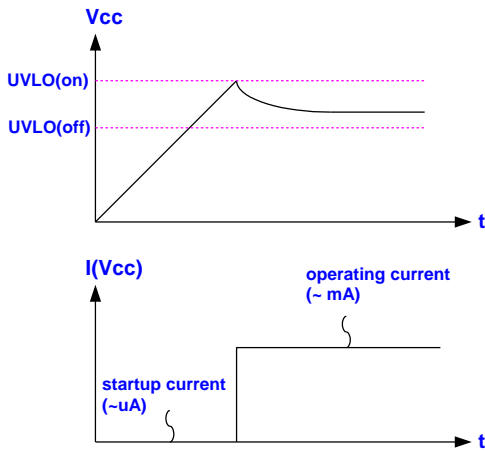

Fig. 9

Startup Current and Startup Circuit

The typical startup circuit to generate VCC of the LD5535A is shown in Fig. 10. During the startup transient, the VCC is below UVLO threshold. Before it has sufficient voltage to develop OUT pulse to drive the power MOSFET, R1 will provide the startup current to charge the capacitor C1. Once VCC obtain enough voltage to turn on the LD5535A and further to deliver the gate drive signal, it will enable the auxiliary winding of the

transformer to provide supply current. Lower startup current requirement on the PWM controller will help to increase the value of R1 and then reduce the power consumption on R1. By using CMOS process and the special circuit design, the maximum startup current for LD5535A is only 3μA.

If a higher resistance value of the R1 is chosen, it will usually take more time to start up. To carefully select the value of R1 and C1 will optimize the power consumption and startup time.

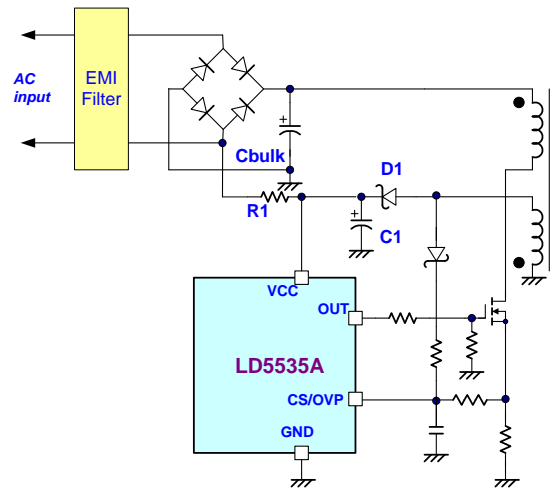

Fig. 10

Current Sensing and Leading-edge Blanking

The typical current mode of PWM controller feedbacks both current signal and voltage signal to close the control loop and achieve regulation. As shown in Fig. 11, the LD5535A detects the primary MOSFET current from the CS pin, which is not only for the peak current mode control but also for the pulse-by-pulse current limit. The maximum voltage threshold of the current sensing pin is set at 0.85V. From above, the MOSFET peak current can be obtained from below.

$$I_{PEAK (MAX)} = \frac{0.85V}{R_S}$$

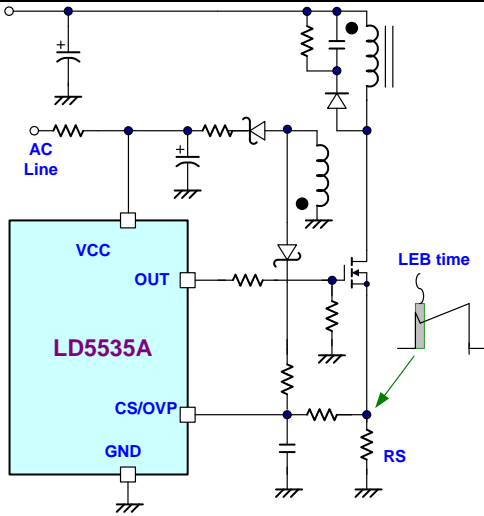

Fig. 11

A leading-edge blanking (LEB) time is included in the input of CS pin to prevent the false-trigger from the current spike.

Output Stage and Maximum Duty-Cycle

An output stage of a CMOS buffer, with typical 250/500mA driving capability, is incorporated to drive a power MOSFET directly. And the maximum duty-cycle of LD5535A is limited to 85% to avoid the transformer saturation.

Voltage Feedback Loop

The voltage feedback signal is provided from the TL431 at the secondary side through the photo-coupler to the COMP pin of the LD5535A. Similar to UC3842, the LD5535A would carry a diode voltage offset at the stage to feed the voltage divider at the ratio of RA and RB, that is,

$$V_{-(PWM_{COMPARATOR})} = \frac{RB}{RA + RB} \times V_{COMP}$$

A pull-high resistor is embedded internally and can be eliminated externally.

Oscillator and Switching Frequency

The LD5535A is implemented with Frequency Swapping function which helps the power supply designers to both

optimize EMI performance and lower system cost. The switching frequency substantially centers at 65KHz, and swap between a range of ± 3.9 KHz.

Green-Mode Operation

By using the green-mode control, the switching frequency can be reduced under the light load condition. This feature helps to improve the efficiency in light load conditions. The green-mode control is Leadtrend Technology's own property. Fig. 12 shows the characteristics of the switching frequency vs. the comp pin voltage (V_{COMP})

On/Off Control

The LD5535A can be turned off by pulling COMP pin lower than 0.6V. The gate output pin of the LD5535A will be disabled immediately under such condition. The off-mode can be released when the pull-low signal is removed.

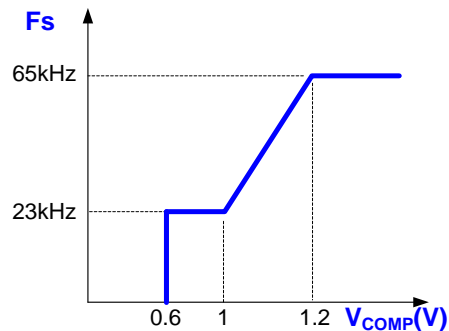

Fig. 12

Internal Slope Compensation

In the conventional applications, the problem of the stability is a critical issue for current mode controlling, when it operates over 50% duty-cycle. As UC384X, It takes slope compensation from injecting the ramp signal of the RT/CT pin through a coupling capacitor. It therefore requires no extra design for the LD5535A since it has integrated it already.

Adjustable Over Current Compensation

In general, the power converter can deliver more current at high input voltage than at low input voltage. To compensate this, an offset voltage is added to the CS signal by an internal current source (I_{OCP}) and an external resistor (R_{OCP}) in series between the sense resistor (R_s) and the CS pin, as shown in Fig. 13. By selecting a proper value of the resistor in series with the CS pin, the amount of compensation can be adjusted. The value of I_{OCP} depends on the duty cycle of OUT pin. The equation of I_{OCP} is decreased as:

$$I_{OCP} = \begin{cases} (0.625 - \text{Duty}) \cdot 480\mu\text{A} & (0.125 < \text{Duty} < 0.625) \\ 0\mu\text{A} & (\text{Duty} \geq 0.625) \\ 240\mu\text{A} & (\text{Duty} \leq 0.125) \end{cases}$$

In light load conditions, the offset should be removed since it is in same order of magnitude as the current sense signal. Therefore the compensation current is only fully added when the COMP voltage is higher than 1.5V.

R_{OCP} : 470Ω~1.2kΩ; C_{OCP} : 47pF~390pF

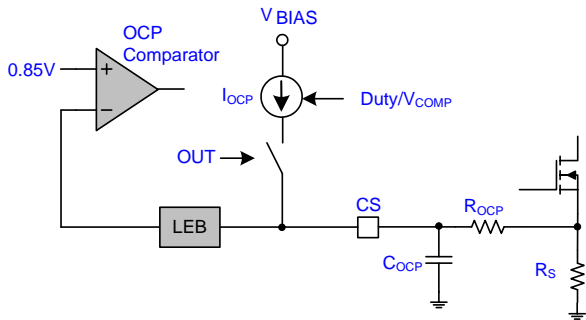

Fig. 13

Over Load Protection (OLP) – Auto Recovery

To protect the circuit from damage in over-load condition and short or open-loop condition, the LD5535A is implemented with smart OLP function. It also features auto recovery function; see Fig. 14 for the waveform. In case of fault condition, the feedback system will force the voltage loop toward the saturation and then pull the voltage high on COMP pin (V_{COMP}). When the V_{COMP}

ramps up to the OLP threshold of 2.6V and continues over OLP delay time, the protection will be activated and then turn off the gate output to stop the switching of power circuit.

With the protection mechanism, the average input power will be minimized to remain the component temperature and stress within the safe operating area.

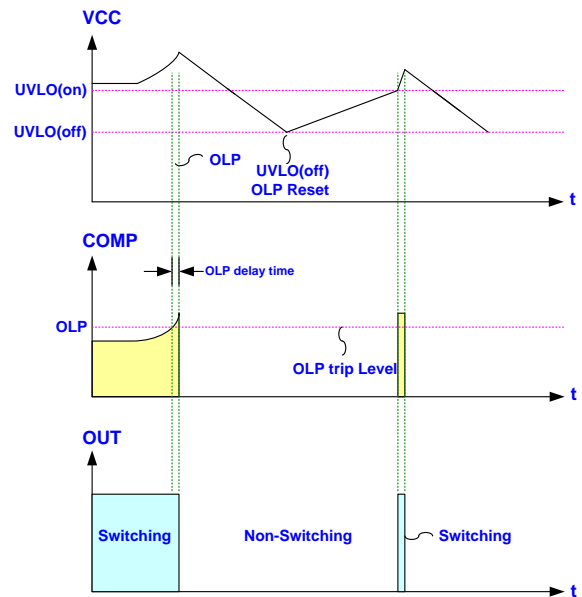

Fig. 14

Over Voltage Protection (OVP) on Vcc – Latch

The Vcc OVP function of LD5535A is in latch mode. As soon as the voltage of the Vcc pin rises above OVP threshold, the output gate drive circuit will be shutdown simultaneous to turn off the power MOSFET. Fig. 15 shows its operation.

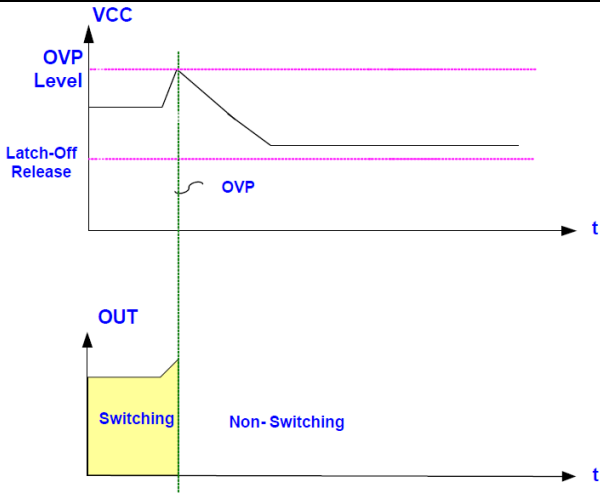

Fig. 15

MOSFET Characteristic

The MOSFET is divided into three operation regions, ohmic region, saturation region, and the cut-off region, shown as Fig. 16.

For switching power supply applications, it shall operate in ohmic and cut-off region. Never reach the region of saturation; it would cause damage for acting beyond the maximum safety operating area. It's necessary to check the characteristic of MOSFET.

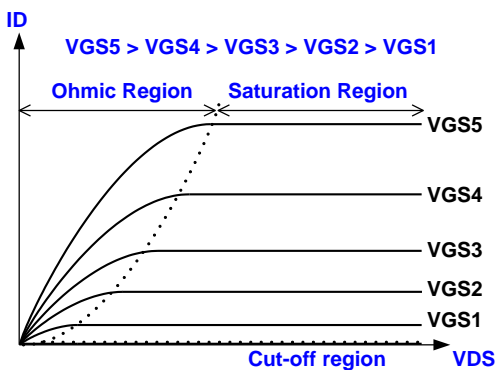

Fig. 16

Output Short Circuit Protection (OSCP) – Auto Recovery

Even when the output shorts to GND, there's no way to turn off the signal unless the following four conditions are met.

1. The CS is higher than limit voltage.

2. The comp voltage is higher than 2.6V
3. This duration is greater than 8 cycles.
4. Turn on time is lower than 1.2us.

The out signal could not be charged either, if it fails to meet the three conditions.

Once the protection is triggered, switching is terminated and the MOSFET remains off.

Output Over Voltage Protection (CS/OVP Pin) – Latch

An output overvoltage protection is implemented in the LD5535A, as shown in Fig. 17 and 18. It senses the auxiliary voltage via the divided resistors. The auxiliary winding voltage is reflected from secondary winding and therefore the flat voltage on the CS/OVP pin is proportional to the output voltage. LD5535A can sample this flat voltage level after a delay time to perform output over voltage protection. This delay time is used to ignore the voltage ringing from leakage inductance of PWM transformer. The sampling voltage level is compared with internal threshold voltage 0.30V. If the sampling voltage exceeds the OVP trip level, an internal counter starts counting subsequent OVP events. The counter has been added to prevent incorrect OVP detection which might occur during ESD or lightning events. However, when typically 8 cycles of subsequent OVP events are detected, the OVP circuit switches the power MOSFET off. As the protection is latch, the converter restarts after the AC is plug out and in.

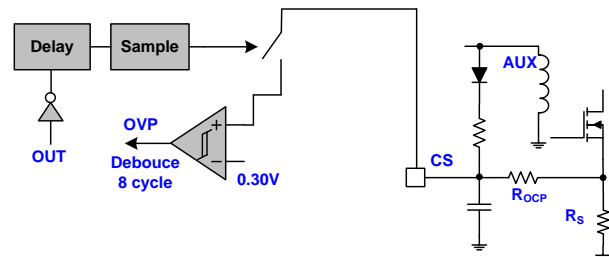

Fig. 17

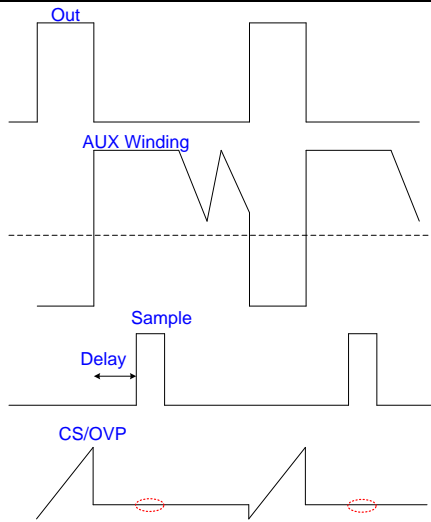

Fig. 18

OTP Pin --- Latched Mode Protection

The OTP circuit is implemented to sense whether there is any hot-spot of power circuit like power MOSFET or output rectifier. Once an over-temperature condition is detected, the OTP is enabled to shut down the controller to protect the controller. Typically, a NTC is recommended to connect with OTP pin. The NTC resistance will decrease as the device or ambient in high temperature. The relationship is as below.

$$V_{OTP} = 100\mu A \cdot R_{NTC}$$

When the V_{OTP} is below the defined voltage threshold (typ. 0.95V), the LD5535A will shut down gate output and latch off the power supply. There are 2 conditions required to restart it successfully. First, cool down the circuit so that NTC resistance will increase and raise V_{OTP} up above 1.05V. Then, remove the AC power cord and re-plug AC power.

Package Information

SOT-26

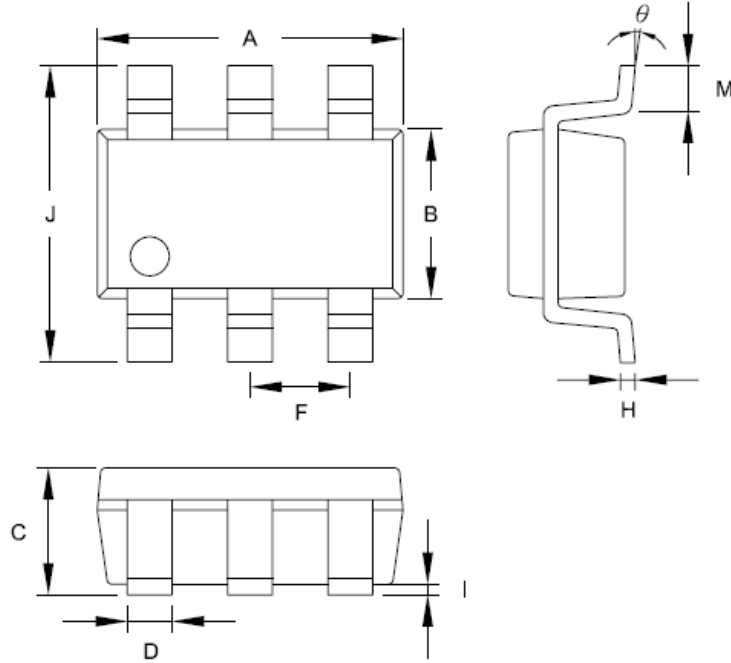

Symbol	Dimension in Millimeters		Dimensions in Inches	
	Min	Max	Min	Max
A	2.692	3.099	0.106	0.122
B	1.397	1.803	0.055	0.071
C	-----	1.450	-----	0.057
D	0.300	0.500	0.012	0.020
F	0.95 TYP		0.037 TYP	
H	0.080	0.254	0.003	0.010
I	0.050	0.150	0.002	0.006
J	2.600	3.000	0.102	0.118
M	0.300	0.600	0.012	0.024
θ	0°	10°	0°	10°

Important Notice

Leadtrend Technology Corp. reserves the right to make changes or corrections to its products at any time without notice. Customers should verify the datasheets are current and complete before placing order.

Revision History

REV.	Date	Change Notice
00	01/26/2016	Original Specification.
01	03/21/2016	Modify Electrical Characteristics