

Green-Mode PWM Controller with Frequency Swapping and Integrated Protections

REV: 02

General Description

The LD5536R is built-in with several functions, protection and EMI-improved solution in a tiny package. It takes less components-counts and circuit space, especially ideal for those total solutions of low cost.

The implemented functions include low startup current, green-mode power-saving operation, leading-edge blanking of the current sensing and internal slope compensation. It also features more protections like OLP (Over Load Protection) and OVP (Over Voltage Protection) to prevent circuit damage occurred under abnormal conditions.

Furthermore, the Frequency Swapping function is to reduce the noise level and thus helps the power circuit designers to easily deal with the EMI filter design by spending minimum amount of component cost and developing time.

Features

- High-Voltage CMOS Process with Excellent ESD protection
- Very Low Startup Current ($<1\mu\text{A}$)
- Current Mode Control
- Green Mode Control
- UVLO (Under Voltage Lockout)
- LEB (Leading-Edge Blanking) on CS Pin
- Internal Frequency Swapping
- Internal Slope Compensation
- OVP (Over Voltage Protection) on Vcc Pin
- Adj. OCP(Over Current Protection) on CS Pin
- OTP (Over Temp. Protection) through a NTC
- OLP (Over Load Protection)
- 250/-500mA Driving Capability

Applications

- Switching AC/DC Adaptor and Battery Charger
- Open Frame Switching Power Supply

Typical Application

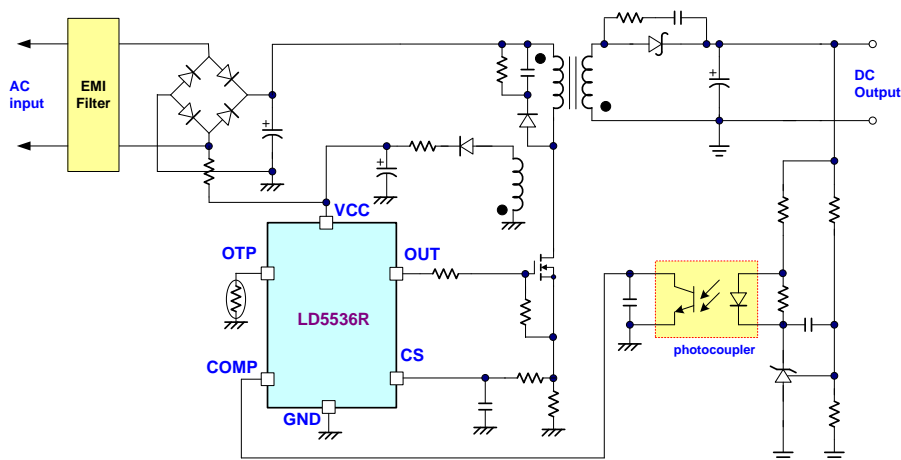

Pin Configuration

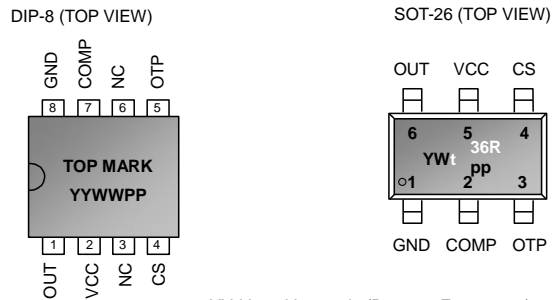

YY, Y : Year code (D: 2004, E: 2005.....)
 WW, W : Week code
 PP : Production code
 t36R : LD5536R

Ordering Information

Part number	Package	Top Mark	Shipping
LD5536R GL	SOT-26	YWt/36R	3000 /tape & reel
LD5536R GN	DIP-8	LD5536R GN	3600 /tube /Carton

The LD5536R is ROHS compliant / Green Packaged

Protection Mode

Switching Freq.	OLP	VCC OVP	OTP Pin
130kHz	Auto recovery	Auto recovery	Latch

Pin Descriptions

SOT-26	DIP-8	NAME	FUNCTION
1	8	GND	Ground
2	7	COMP	Voltage feedback pin (same as the COMP pin in UC384X). Connect a photo-coupler to close the control loop and achieve the regulation.
3	5	OTP	Pull this pin below 0.95V to shut down the controller into latch mode until the system is repowered. Connecting this pin to ground with NTC will achieve OTP protection. Let this pin float or connect a 100kΩ resistor to disable the latch protection.
4	4	CS	Current sense pin, connect it to sense the MOSFET current.
5	2	VCC	Supply voltage pin
6	1	OUT	Gate drive output to drive the external MOSFET

Block Diagram

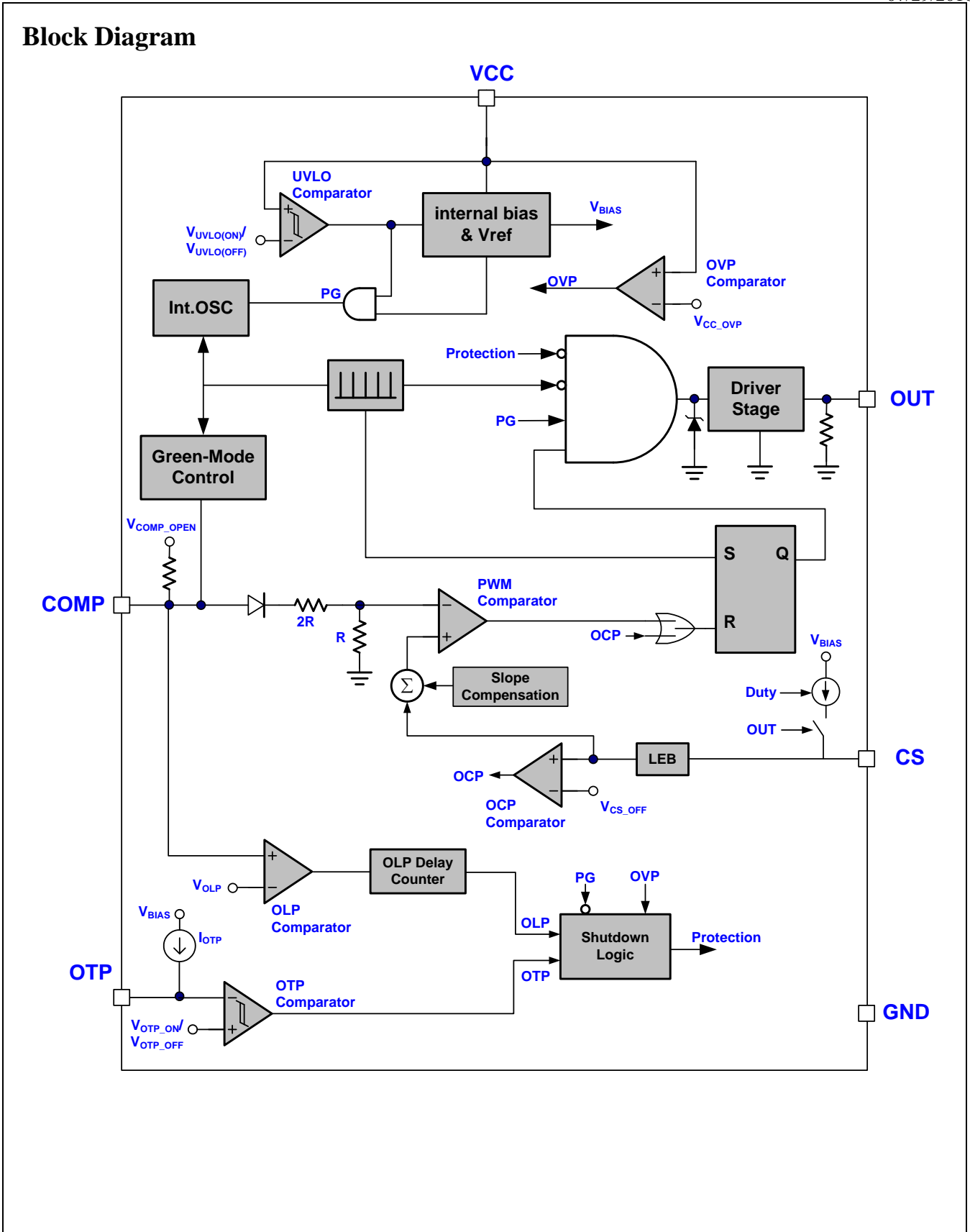

Absolute Maximum Ratings

Supply Voltage VCC.....	-0.3V ~30V
COMP, OTP, CS.....	-0.3V ~6V
OUT.....	-0.3V ~Vcc+0.3V
Maximum Junction Temperature.....	150°C
Storage Temperature Range.....	-65°C to 150°C
Package Thermal Resistance (SOT-26, θ_{JA}).....	200°C/W
Package Thermal Resistance (DIP-8, θ_{JA}).....	100°C/W
Power Dissipation (SOT-26, at Ambient Temperature = 85°C).....	200mW
Power Dissipation (DIP-8, at Ambient Temperature = 85°C).....	400mW
Lead temperature (Soldering, 10sec).....	260°C
ESD Voltage Protection, Human Body Model.....	2.5 KV
ESD Voltage Protection, Machine Model.....	250 V

Caution:

Stress exceeding Maximum Ratings may damage the device. Maximum Ratings are stress ratings only. Functional operation above the Recommended Operating Conditions is not implied. Extended exposure to stress above Recommended Operating Conditions may affect device reliability

Recommended Operating Conditions

Item	Min.	Max.	Unit
Operating Junction Temperature	-40	125	°C
Supply VCC Voltage	8.0	26.5	V
VCC Capacitor	3.3	10	μF
Start-up resistor Value (AC Side, Half Wave)	400K	2M	Ω
Comp Pin Capacitor	1	10	nF
CS Pin Capacitor Value	47	470	pF

Note:

1. It's essential to connect VCC pin with a SMD ceramic capacitor (0.1μF~0.47μF) to filter out the undesired switching noise for stable operation. This capacitor should be placed close to IC pin as possible
2. It's also essential to connect a capacitor to COMP to filter out the undesired switching noise for stable operation.
3. The small signal components should be placed close to IC pin as possible.

Electrical Characteristics

($T_A = +25^\circ\text{C}$ unless otherwise stated, $V_{CC}=15.0\text{V}$)

PARAMETER	CONDITIONS	SYM.	MIN	TYP	MAX	UNITS
Supply Voltage (Vcc Pin)						
Startup Current	$V_{CC} < UVLO$ (ON)	I_{CC_ST}	---	0.6	1	μA
Operating Current (with 1nF load on OUT pin)	$V_{COMP}=3\text{V}$	I_{CC_OP1}	2.68	3.1	3.52	mA
	$V_{COMP}=0\text{V}$	I_{CC_OP2}	0.53	0.65	0.77	mA
	OLP/OVP Tripped / Auto, OTP=3V	I_{CC_OPA}	0.48	0.52	0.64	mA
	OTP Pin Tripped / Latch	I_{CC_OPL1}	0.70	0.83	0.98	mA
Latch-Off Release Voltage		V_{CC_PDR}	3.7	4.3	5.1	V
Holding Current	$V_{CC}=10\text{V}$ (Latched)	I_{CC_OPL2}	360	450	540	μA
UVLO (off)	OUT OFF	V_{CC_OFF}	7.0	7.5	8.0	V
UVLO (on)		V_{CC_ON}	15	16	17	V
VCC OVP Level		V_{CC_OVP}	27.5	28.5	29.5	V
VCC OVP De-bounce time	*	T_{D_VCCOVP}	---	8	---	cycle
VCC OSCP	*COMP > 4.6V	V_{CC_OSCP}	---	9	---	V
VCC OSCP De-bounce Time	*	T_{D_OSCP}	---	15	---	ms
Voltage Feedback (Comp Pin)						
Short Circuit Current	$V_{COMP}=0\text{V}$	I_{COMP}	0.09	0.125	0.16	mA
Open Loop Voltage	COMP pin open	V_{COMP_OPEN}	4.7	5	5.3	V
Green Mode Threshold VCOMP	*	V_G	---	2.575	---	V
Zero Duty Threshold VCOMP		V_{ZDC}	1.5	1.6	1.7	V
Zero Duty Hysteresis		V_{ZDCH}	70	100	130	mV
Current Sensing (CS pin)						
Maximum Input Voltage, V_{CS_OFF}		V_{CS_MAX}	0.8	0.85	0.9	V
Max. OCP Compensation Current, I_{OCP}		I_{OCP}	223	240	257	μA
Leading Edge Blanking Time, LEB		T_{LEB}	150	200	250	ns
Internal Slope Compensation	* $t_{on} > 3.5\mu\text{s}$ to D_{MAX} . (Linearly increase)	V_{SLP_L}	---	300	---	mV
Input impedance	*	Z_{CS}	1	---	---	$\text{M}\Omega$
Delay to Output	*	T_{PD}	---	100	---	ns
Soft Start Duration	*	T_{SS}	---	6.5	---	ms

PARAMETER	CONDITIONS	SYM.	MIN	TYP	MAX	UNITS
Oscillator for Switching Frequency						
Frequency, FREQ		F _{SW}	120	130	140	kHz
Green Mode Frequency, FREQG		F _{SW_GREEN}	21.5	25	28.5	kHz
Frequency Swapping	V _{COMP} >2.575V	F _{SW_MOD}	---	± 10.0	---	kHz
Temp. Stability	(-20°C ~85°C)*	F _{SW_TS}	0	5	---	%
Voltage Stability	(V _{CC} =11V-25V)*	F _{SW_VS}	0	1	---	%
Gate Drive Output (OUT Pin)						
Output Low Level	V _{CC} =15V, I _o =20mA	V _{OL}	---	---	1	V
Output High Level	V _{CC} =15V, I _o =20mA	V _{OH}	8	---	15	V
Output High Clamp Level	V _{CC} =20V	V _{O_CLAMP}	13	15	17	V
Rising Time	Load Capacitance=1000pF*	T _r	---	150	250	ns
Falling Time	Load Capacitance=1000pF*	T _f	---	50	75	ns
Max. Duty		MXD	68	71	74	%
OLP (Over Load Protection)						
OLP Trip Level		V _{OLP}	4.3	4.5	4.7	V
OLP Delay Time at start-up	OLP + Soft start*	T _{D_OLPSS}	---	71.5	---	ms
OLP Delay Time after start-up		T _{D_OLP}	57	63	69	ms
OTP Pin Latch Protection (OTP Pin)						
OTP Pin Source Current		I _{OTP}	93	100	107	μA
OTP Turn-On Trip Level		V _{OTP_ON}	1.00	1.05	1.10	V
OTP Turn-Off Trip Level		V _{OTP_OFF}	0.9	0.95	1.0	V
OTP Turn-Off Trip Resistance	=V _{OTP-OFF} /I _{OTP} *	R _{OTP}	8.75	9.5	10.25	Ω
OTP pin de-bounce time	V _{COMP} > 3V	T _{D_OTP}	200	250	300	μs
Internal OTP Latch Protection						
OTP Tripped Level	*	T _{INOTP}	---	140	---	°C
OTP Hysteresis	*	T _{INOTP_HYS}	---	30	---	°C

*: Guaranteed by design.

Typical Performance Characteristics

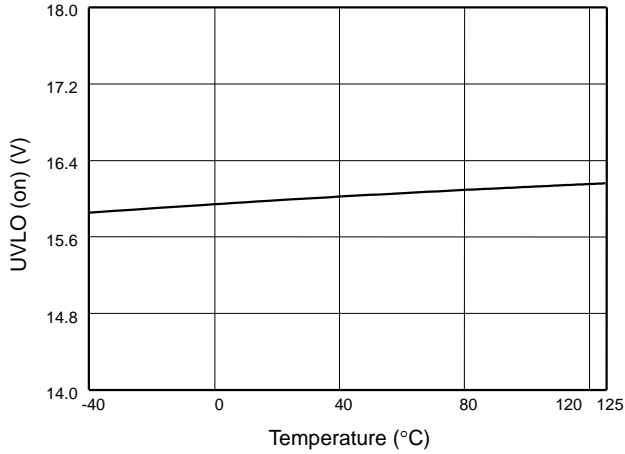

Fig. 1 UVLO (on) vs. Temperature

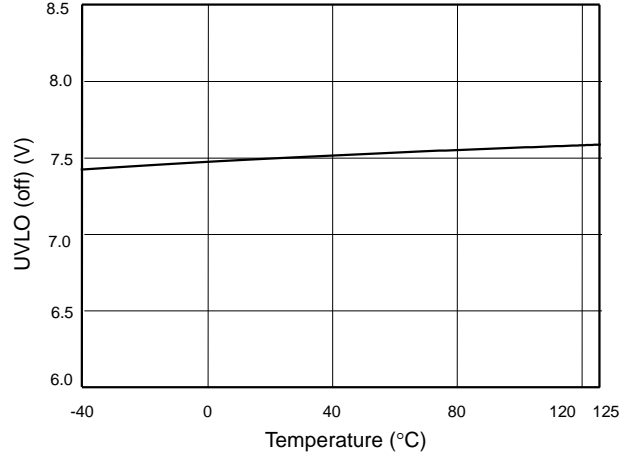

Fig. 2 UVLO (off) vs. Temperature

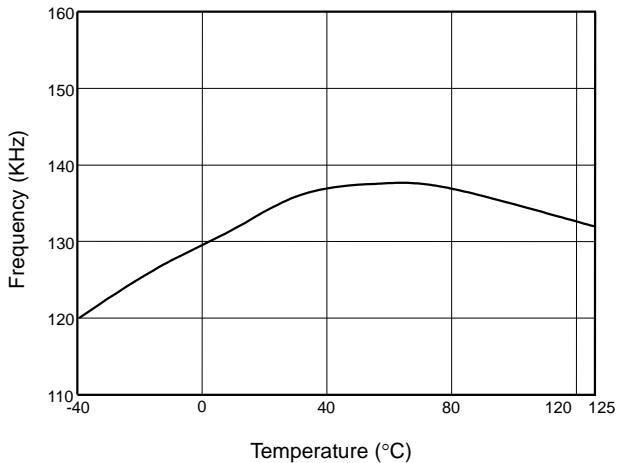

Fig. 3 Frequency vs. Temperature

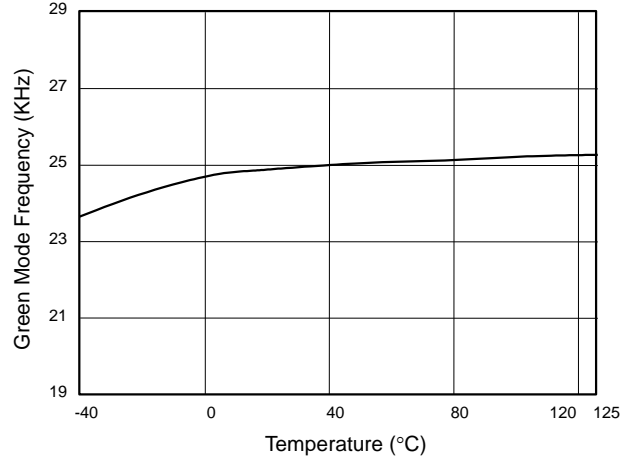

Fig. 4 Green Mode Frequency vs. Temperature

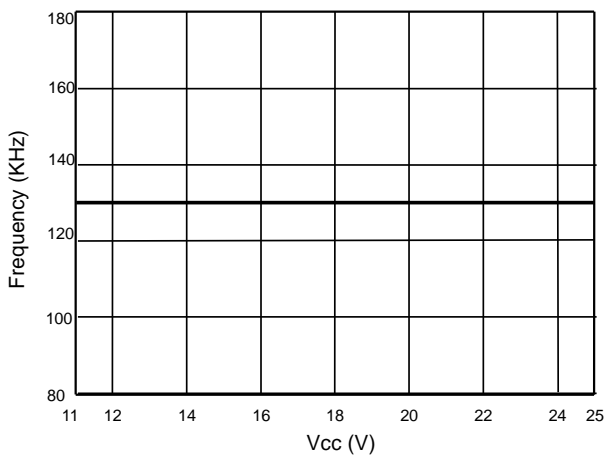

Fig. 5 Frequency vs. Vcc

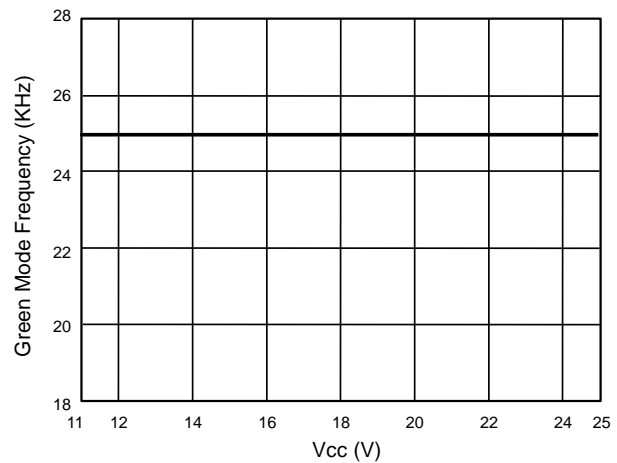

Fig. 6 Green Mode Frequency vs. Vcc

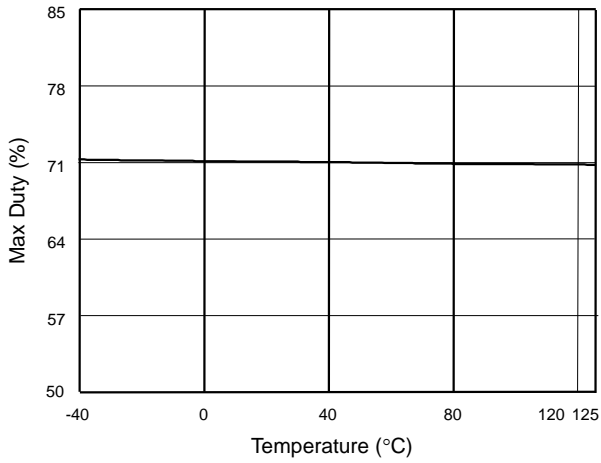

Fig. 7 Max Duty vs. Temperature

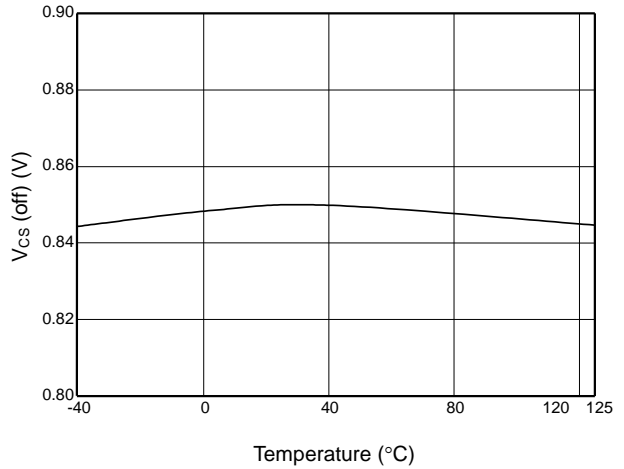

Fig. 8 V_{CS} (off) vs. Temperature

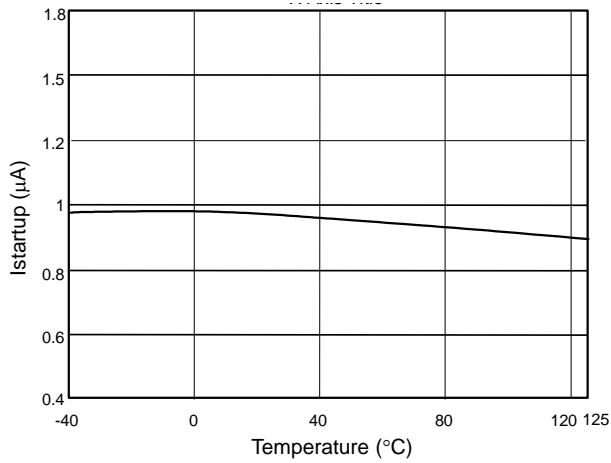

Fig. 9 Start-up Current (I_{start-up}) vs. Temperature

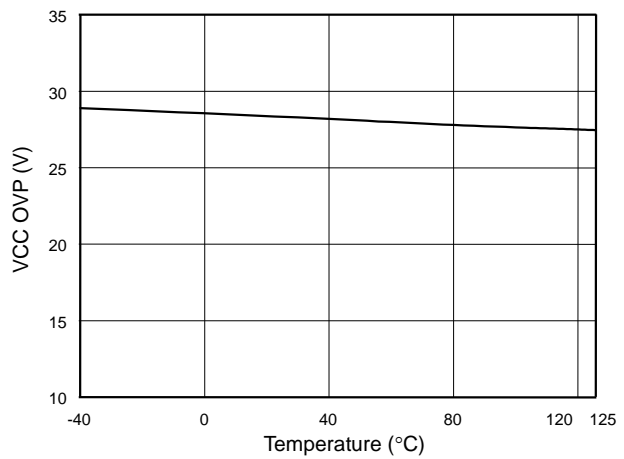

Fig. 10 V_{CC} OVP vs. Temperature

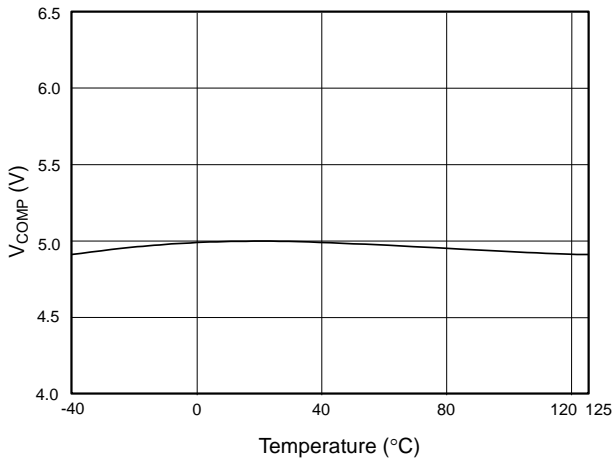

Fig. 11 V_{COMP} open loop voltage vs. Temperature

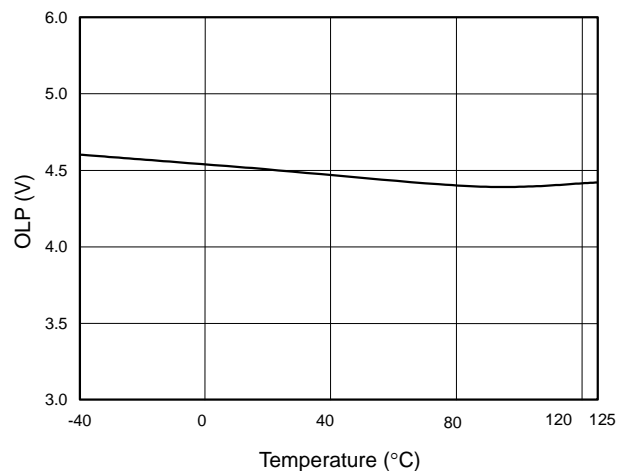

Fig. 12 OLP-Trip Level vs. Temperature

Application Information

Operation Overview

The LD5536R meets the green-power requirement and is intended for the use in those modern switching power suppliers and adaptors which demand higher power efficiency and power-saving. It integrated more functions to reduce the external components counts and the size. Its major features are described as below.

Under Voltage Lockout (UVLO)

An UVLO comparator is implemented in it to detect the voltage on the VCC pin. It would assure the supply voltage enough to turn on the LD5536R PWM controller and further to drive the power MOSFET. As shown in Fig. 13, a hysteresis is built in to prevent the shutdown from the voltage dip during startup.

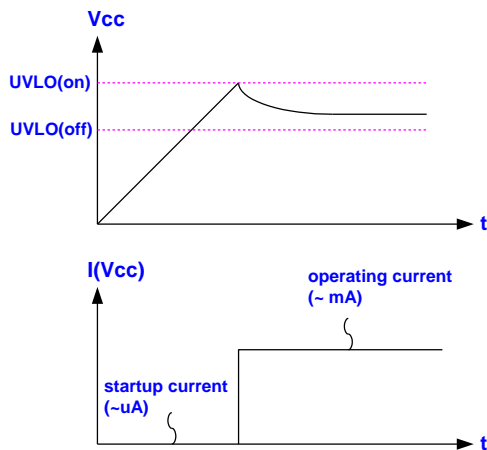

Fig. 13

Startup Current and Startup Circuit

The typical startup circuit to generate V_{CC} of the LD5536R is shown in Fig. 14. During the startup transient, the V_{CC} is below UVLO threshold. Before it has sufficient voltage to develop OUT pulse to drive the power MOSFET, R₁ will provide the startup current to charge the capacitor C₁. Once V_{CC} obtain enough voltage to turn on the LD5536R and further to deliver the gate drive signal, it will enable the auxiliary winding of the transformer to provide supply

current. Lower startup current requirement on the PWM controller will help to increase the value of R₁ and then reduce the power consumption on R₁. By using CMOS process and the special circuit design, the maximum startup current for the LD5536R is only 1μA.

If a higher resistance value of the R₁ is chosen, it will usually take more time to start up. To carefully select the value of R₁ and C₁ will optimize the power consumption and startup time.

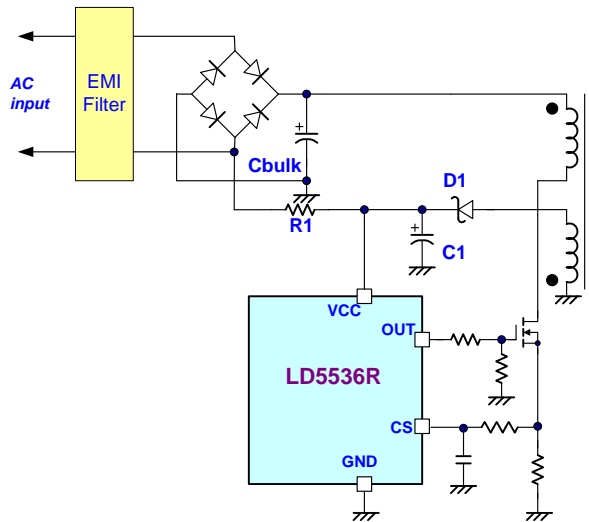

Fig. 14

Current Sensing and Leading-edge Blanking

The typical current mode of PWM controller feedbacks both current signal and voltage signal to close the control loop and achieve regulation. As shown in Fig. 15, the LD5536R detects the primary MOSFET current from the CS pin, which is not only for the peak current mode control but also for the pulse-by-pulse current limit. The maximum voltage threshold of the current sensing pin is set at 0.85V. From above, the MOSFET peak current can be obtained from below.

$$I_{PEAK(MAX)} = \frac{0.85V}{R_S}$$

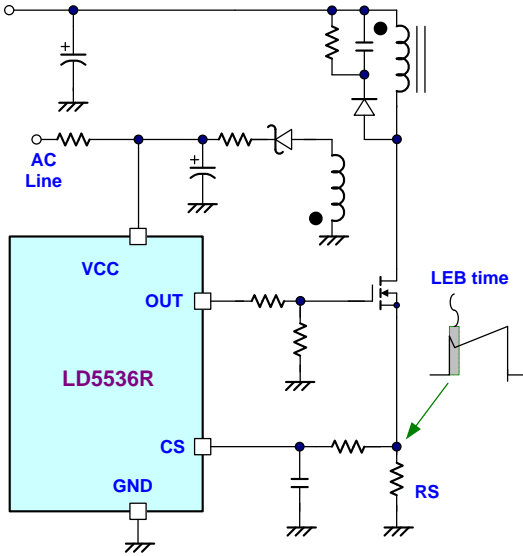

Fig. 15

A leading-edge blanking (LEB) time is included in the input of CS pin to prevent the false-trigger from the current spike.

Output Stage and Maximum Duty-Cycle

An output stage of a CMOS buffer, with typical 250/-500mA driving capability, is incorporated to drive a power MOSFET directly. And the maximum duty-cycle of the LD5536R is limited to 71% to avoid the transformer saturation.

Voltage Feedback Loop

The voltage feedback signal is provided from the TL431 at the secondary side through the photo-coupler to the COMP pin of the LD5536R. Similar to UC3842, the LD5536R would carry a diode voltage offset at the stage to feed the voltage divider at the ratio of R and 2R, that is,

$$V_{(PWM_COMPARATOR)} = \frac{R}{R + 2R} \times (V_{COMP} + V_F)$$

A pull-high resistor is embedded internally and can be eliminated externally.

Oscillator and Switching Frequency

The LD5536R is implemented with Frequency Swapping function which helps the power supply designers to both

optimize EMI performance and lower system cost. The switching frequency substantially centers at 130KHz, and swap between a range of ± 10 KHz.

Green-Mode Operation

By using the green-mode control, the switching frequency can be reduced under the light load condition. This feature helps to improve the efficiency in light load conditions. The green-mode control is Leadtrend Technology's own property. Fig. 16 shows the characteristics of the switching frequency vs. the comp pin voltage (V_{COMP})

On/Off Control

The LD5536R can be turned off by pulling COMP pin lower than 1.6V. The gate output pin of the LD5536R will be disabled immediately under such condition. The off-mode can be released when the pull-low signal is removed.

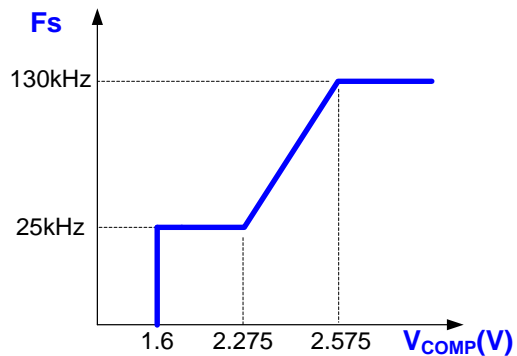

Fig. 16

Internal Slope Compensation

In the conventional applications, the problem of the stability is a critical issue for current mode controlling, when it operates over 50% duty-cycle. As UC384X, It takes slope compensation from injecting the ramp signal of the RT/CT pin through a coupling capacitor. It therefore requires no extra design for the LD5536R since it has integrated it already.

Adjustable Over Current Compensation (CS Pin)

In general, the power converter can deliver more current at high input voltage than at low input voltage. To compensate this, an offset voltage is added to the CS signal by an internal current source (I_{OCP}) and an external resistor (R_{OCP}) in series between the sense resistor (R_s) and the CS pin, as shown in Fig. 17. By selecting a proper value of the resistor in series with the CS pin, the amount of compensation can be adjusted. The value of I_{OCP} depends on the duty cycle of OUT pin.

In light load conditions, the offset should be removed since it is in same order of magnitude as the current sense signal. Therefore the compensation current is only fully added when the COMP voltage is higher than 2.9V.

R_{OCP} : 470Ω~1.2kΩ; C_{OCP} : 47pF~390pF

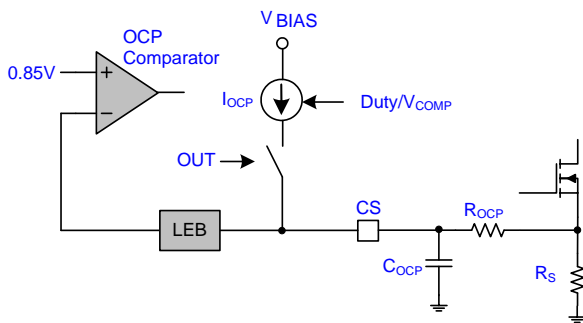

Fig. 17

Over Load Protection (OLP) –Auto Recovery

To protect the circuit from damage in over-load condition and short or open-loop condition, the LD5536R is implemented with smart OLP function. It also features auto recovery function; see Fig. 18 for the waveform. In case of fault condition, the feedback system will force the voltage loop toward the saturation and then pull the voltage high on COMP pin (V_{COMP}). When the V_{COMP} ramps up to the OLP threshold of 4.5V and continues over OLP delay time, the protection will be activated and then turn off the gate output to stop the switching of power circuit.

With the protection mechanism, the average input power will be minimized to remain the component temperature and stress within the safe operating area.

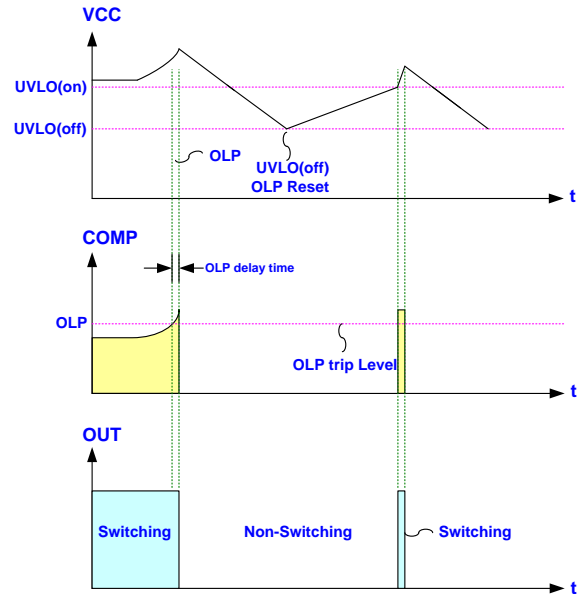

Fig. 18

Over Voltage Protection (OVP) on Vcc - Auto Recovery

The Vcc OVP function of the LD5536R is in auto recovery mode. As soon as the voltage of the Vcc pin rises above OVP threshold, the output gate drive circuit will be shutdown simultaneous to turn off the power MOSFET. Fig. 19 shows its operation.

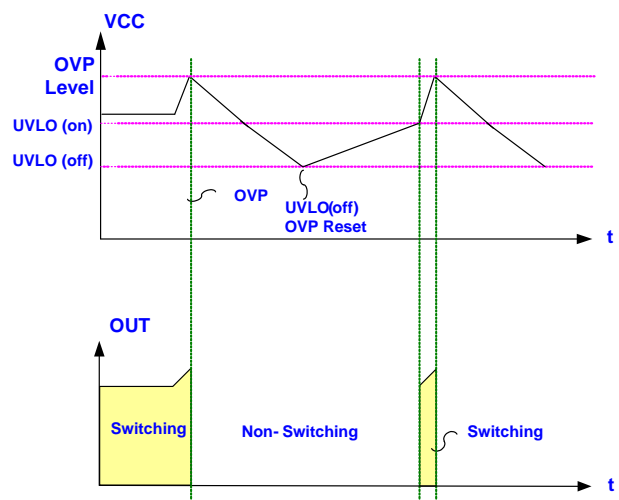

Fig. 19

OTP Pin --- Latched Mode Protection

The OTP circuit is implemented to sense whether there is any hot-spot of power circuit like power MOSFET or output rectifier. Once an over-temperature condition is detected, the OTP is enabled to shut down the controller to protect the controller. Typically, a NTC is recommended to connect with OTP pin. The NTC resistance will decrease as the device or ambient in high temperature. The relationship is as below.

$$V_{OTP} = 100\mu A \cdot R_{NTC}$$

When the V_{OTP} is lower than the defined voltage threshold (typ. 0.95V), the LD5536R will shut down the gate output and latch off the power supply. There are 2 conditions required to restart it successfully. First, cool down the circuit so that NTC resistance will increase and raise V_{OTP} up above 1.05V. Then, remove the AC power cord and re-plug AC power.

MOSFET Characteristic

The MOSFET is divided into three operation regions, ohmic region, saturation region, and the cut-off region, shown as Fig. 20.

For switching power supply applications, it shall operate in ohmic and cut-off region. Never reach the region of saturation; it would cause damage for acting beyond the maximum safety operating area. It's necessary to check the characteristic of MOSFET.

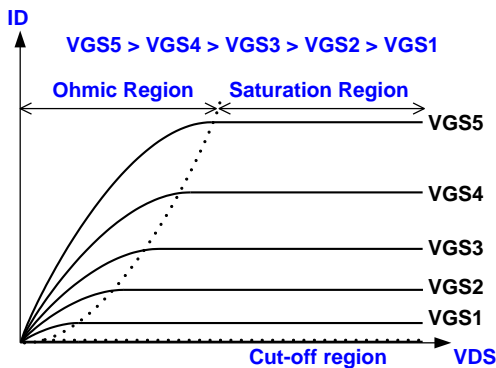

Fig. 20

Output Short Circuit Protection (OSCP) – Auto Recovery

The OSCP function is to prevent the damage from output short circuit. Once the output is shorted, V_o and V_{CC} drop immediately. And according to the close loop control, COMP voltage will pull high in the meanwhile. If the V_{COMP} pulls high to over 4.5 V for over 15 ms and V_{CC} drops below 9 V. At this time, the OSCP protection will be triggered and turn off the gate driving.

Package Information

SOT-26

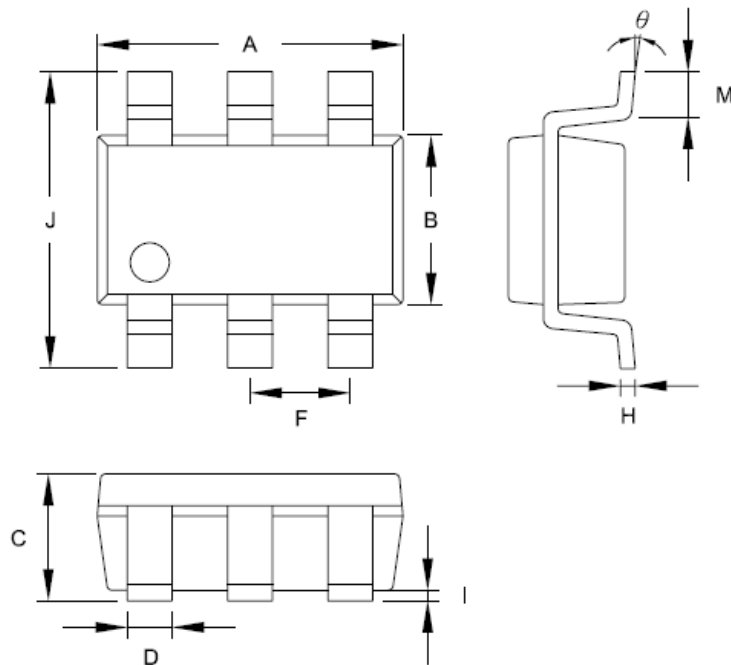

Symbol	Dimension in Millimeters		Dimensions in Inches	
	Min	Max	Min	Max
A	2.692	3.099	0.106	0.122
B	1.397	1.803	0.055	0.071
C	-----	1.450	-----	0.057
D	0.300	0.500	0.012	0.020
F	0.95 TYP		0.037 TYP	
H	0.080	0.254	0.003	0.010
I	0.050	0.150	0.002	0.006
J	2.600	3.000	0.102	0.118
M	0.300	0.600	0.012	0.024
θ	0°	10°	0°	10°

Package Information

DIP-8

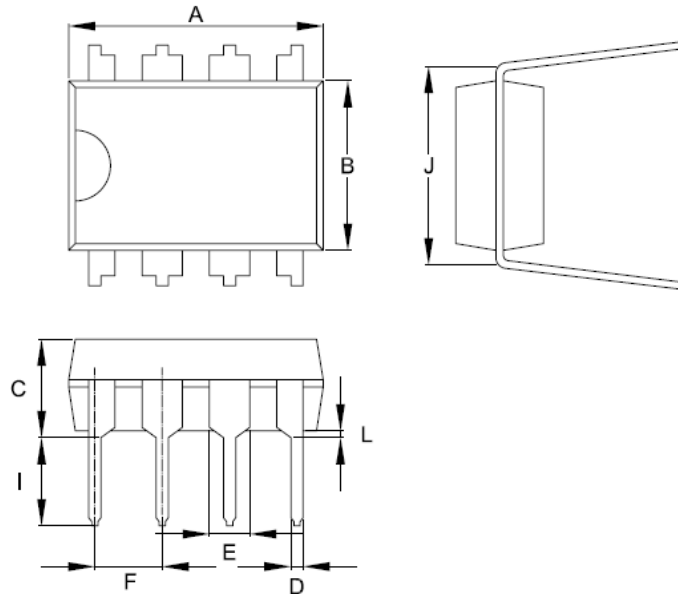

Symbol	Dimension in Millimeters		Dimensions in Inches	
	Min	Max	Min	Max
A	9.017	10.160	0.355	0.400
B	6.096	7.112	0.240	0.280
C	-----	5.334	-----	0.210
D	0.356	0.584	0.014	0.023
E	1.143	1.778	0.045	0.070
F	2.337	2.743	0.092	0.108
I	2.921	3.556	0.115	0.140
J	7.366	8.255	0.29	0.325
L	0.381	-----	0.015	-----

Important Notice

Leadtrend Technology Corp. reserves the right to make changes or corrections to its products at any time without notice. Customers should verify the datasheets are current and complete before placing order.

Revision History

REV.	Date	Change Notice
00	08/24/2015	Original Specification.
01	04/14/2016	1. Add Vcc Holding Voltage spec. 2. Modify I _{CC_OP1} Spec: 2.9mA → 2.68mA(Min.), 3.3mA→3.52mA(Max.)
02	07/29/2016	Delete Vcc Holding Voltage spec.