

Green-Mode PWM Controller with Frequency Swapping and Integrated Protections

REV. 00

General Description

The LD5537B1/I1 is built-in with several functions, protection and EMI-improved solution in a tiny package. It takes less components counts or circuit space, especially ideal for those total solutions of low cost.

The implemented functions include low startup current, green-mode power-saving operation, leading-edge blanking of the current sensing and internal slope compensation. It also features more protections like OLP (Over Load Protection) · OVP (Over Voltage Protection) and AC BNI / BNO to prevent circuit damage occurred under abnormal conditions.

Furthermore, the frequency swapping function is to reduce the noise level and thus helps the power circuit designers to easily deal with the EMI filter design by spending minimum amount of component cost and developing time.

Features

- High-Voltage CMOS Process with Excellent ESD protection
- Very Low Startup Current (<3μA)
- Multi-Mode PWM controller
- Current Mode Control
- Green Mode Control
- UVLO (Under Voltage Lockout)
- LEB (Leading-Edge Blanking) on CS Pin
- Internal Frequency Swapping, Slope Compensation
- OVP (Over Voltage Protection) on VCC and CS Pin
- Adjustment input AC BNI / BNO
- OLP (Over Load Protection)
- OSCP (Output Short Circuit Protection)
- 250mA/500mA Driving Capability

Applications

- Switching AC/DC Adaptor and Battery Charger
- Open Frame Switching Power Supply

Typical Application

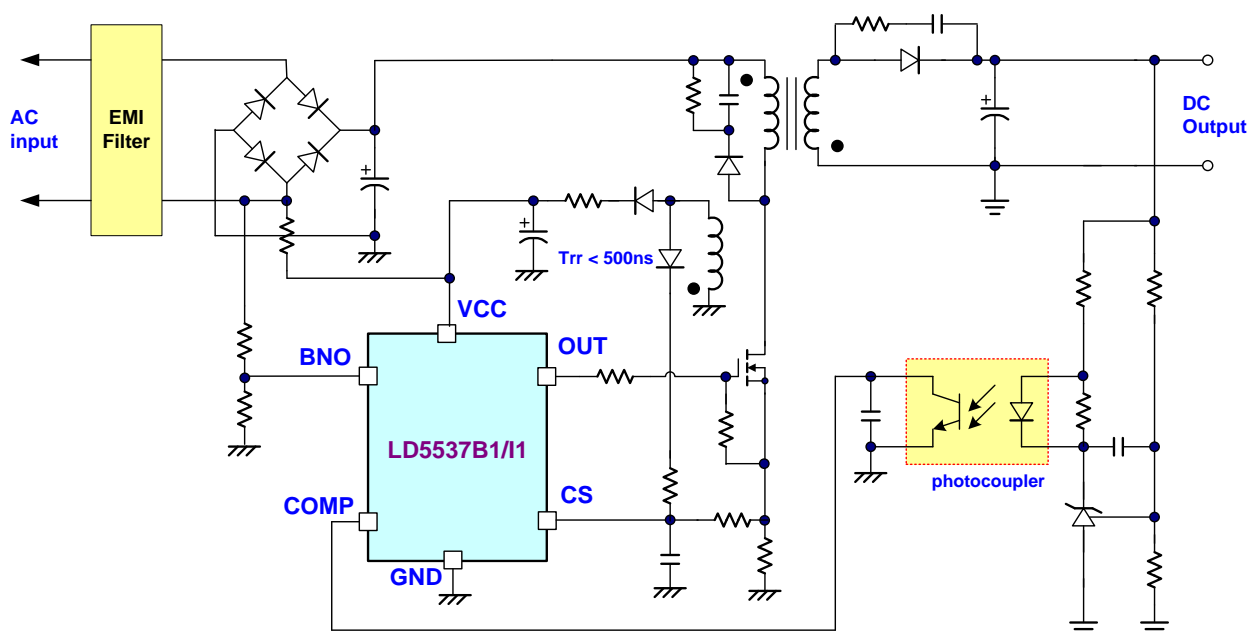

Pin Configuration

SOT-26 (TOP VIEW)

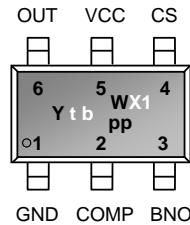

Y : Year code (D: 2004, E: 2005.....)
W : Week code
PP : Production code
tbX1 : LD5537B1 & LD5537I1

Ordering Information

Part number	Package	Top Mark	Shipping
LD5537B1 GL	SOT-26	Yt b/ WB1	3000 / tape & reel
LD5537I1 GL	SOT-26	Yt b/ WI1	3000 / tape & reel

The LD5537B1/I1 is ROHS compliant / green packaged.

Protection Mode

Product Name	Switching Freq.	OLP	VCC OVP	CS OVP	OSCP	SDSP	BNO Pin	Int. OTP
LD5537B1	100kHz	Auto recovery	Auto recovery	Auto recovery	Auto recovery	Auto recovery	Auto recovery	Auto recovery
LD5537I1	100kHz	Latch	Latch	Latch	Latch	Latch	Auto recovery	Auto recovery

Pin Descriptions

SOT-26	NAME	FUNCTION
1	GND	Ground
2	COMP	Voltage feedback pin (same as the COMP pin in UC384X). Connect a photo-coupler to close the control loop and achieve the regulation.
3	BNO	Brownout Protection Pin. Connect a resistor divider between this pin and bridge rectifier of AC input to set the brownout level. If the voltage is less than threshold voltage, the PWM output will be disabled.
4	CS	Current sense pin, connect it to sense the MOSFET current.
5	VCC	Supply voltage pin
6	OUT	Gate drive output to drive the external MOSFET

Block Diagram

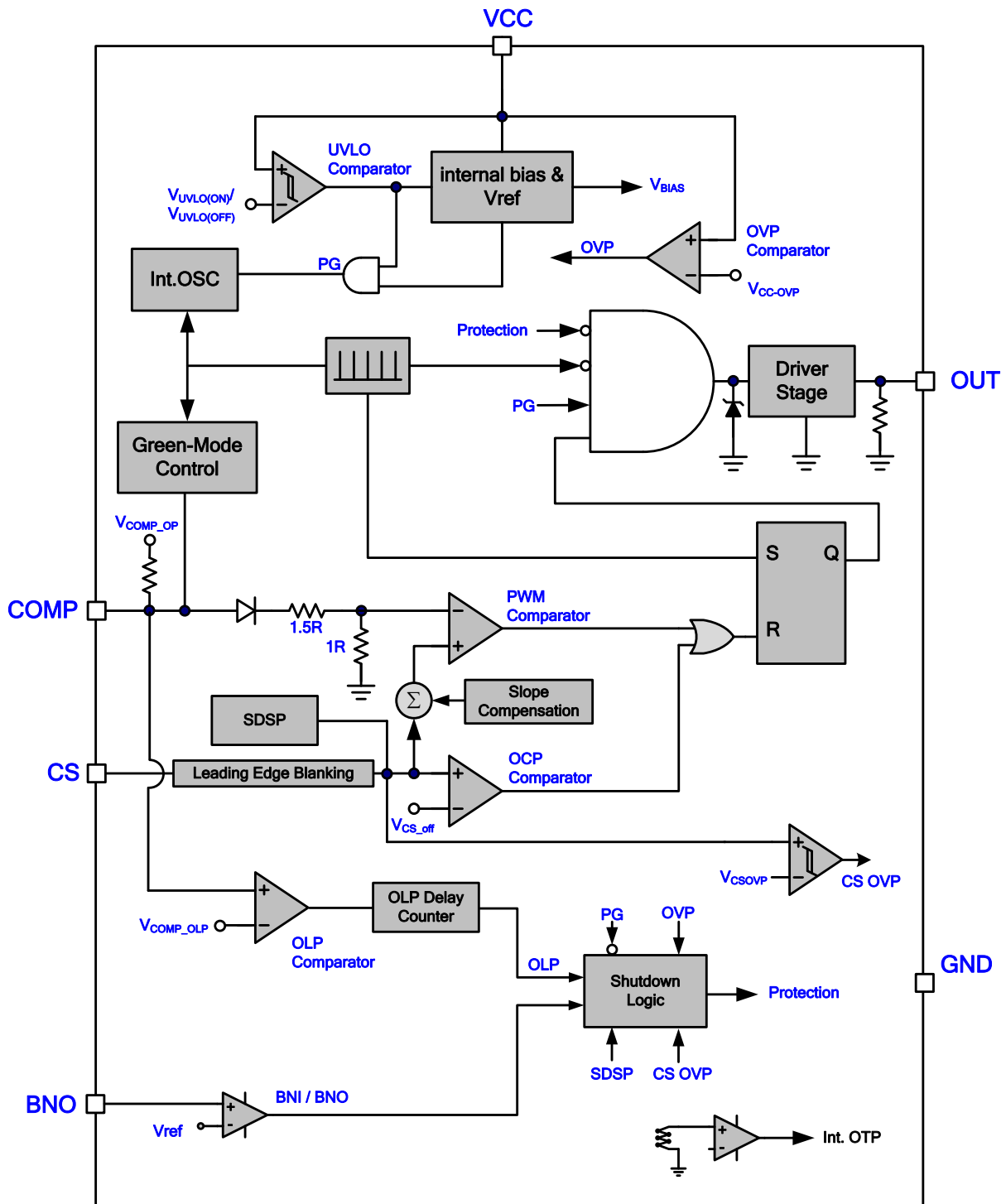

Absolute Maximum Ratings

Supply Voltage VCC.....	-0.3V ~ 30V
COMP, CS, BNO.....	-0.3V ~ 6V
OUT.....	-0.3V ~ VCC+0.3V
Maximum Junction Temperature.....	150°C
Storage Temperature Range.....	-65°C ~ 150°C
Package Thermal Resistance (SOT-26, θ_{JA}).....	200°C/W
Power Dissipation (SOT-26, at Ambient Temperature = 85°C).....	200mW
Lead temperature (Soldering, 10sec).....	260°C
ESD Voltage Protection, Human Body Model.....	2.5 KV
ESD Voltage Protection, Machine Model.....	250 V

Caution:

Stress exceeding maximum ratings may damage the device. Maximum ratings are stress ratings only. Functional operation above the recommended operating conditions is not implied. Extended exposure to stress above recommended operating conditions may affect device reliability.

Recommended Operating Conditions

Item	Min.	Max.	Unit
Operating Junction Temperature	-40	125	°C
Supply VCC Voltage	8.5	26.5	V
VCC Capacitor	3.3	10	μF
Start-up resistor Value (AC Side, Half Wave)	540K	2.2M	Ω
COMP Pin Capacitor	1	10	nF
CS Pin Capacitor Value	47	390	pF

Note:

1. It's essential to connect VCC pin with a SMD ceramic capacitor (0.1μF ~ 0.47μF) to filter out the undesired switching noise for stable operation. This capacitor should be placed close to IC pin as possible.
2. It's also essential to connect a capacitor to COMP to filter out the undesired switching noise for stable operation.
3. The small signal components should be placed close to IC pin as possible.

Electrical Characteristics

($T_A = +25^\circ\text{C}$ unless otherwise stated, $V_{CC}=15.0\text{V}$)

PARAMETER	CONDITIONS	SYMBOL	MIN	TYP	MAX	UNITS
Supply Voltage (VCC Pin)						
Startup Current	$V_{CC} < UVLO(ON)$	I_{CC_ST}			3	μA
Operating Current (with 1nF load on OUT Pin)	$V_{COMP}=0\text{V}$, $OUT=1\text{nF}$	I_{CC_OP1}		0.285		mA
	$V_{COMP}=1.7\text{V}$, $OUT=1\text{nF}$	I_{CC_OP2}		2.9		mA
	Auto current protection	I_{CC_OPA1}		0.6		mA
	Latch current protection	I_{CC_OPA2}		0.8		mA
UVLO(OFF)	OUT OFF	V_{CC_OFF}	6.5	7.5	8.5	V
UVLO(ON)		V_{CC_ON}	15	16	17	V
VCC OVP Level		V_{CC_OVP}	27	28	29	V
VCC OVP de-bounce time		T_{VCC_OVP}		8		Cycle
Latch-Off Release Voltage		V_{PDR}	4.1	4.8	5.5	V
Voltage Feedback (Comp Pin)						
Short Circuit Current	$V_{COMP}=0\text{V}$	I_{COMP}		0.116		mA
Open Loop Voltage		V_{COMP_OPEN}		3.15		V
Zero Duty Threshold V_{COMP}		V_{ZDC}		0.5		V
Zero Duty Hysteresis		V_{ZDCH}		100		mV
Current Sensing (CS pin)						
Maximum Input Voltage (V_{CS_OFF})		V_{CS_LIMIT}		0.815		V
Maximum Input Voltage (V_{CS_MIN})	For High Line	V_{CS_MIN}		0.645		V
Leading Edge Blanking Time		T_{LEB}		200		ns
Internal Slope Compensation	0% to D_{MAX} . (Linearly increase) *	V_{SLP_L}		330		mV
Input impedance	*	Z_{CS}	1			$M\Omega$
Delay to Output	*	T_{PD}		100		ns
Gate Drive Output (OUT Pin)						
Output Low Level	$V_{CC} = 15\text{V}$, $I_o=20\text{mA}^{(1)}$	V_{OL}			1	V
Output High Level	$V_{CC} = 15\text{V}$, $I_o=20\text{mA}$	V_{OH}	9		14	V
Rising Time	$V_{CC} = 15\text{V}$ $C_L=1000\text{pF}$	T_r		200		ns
Falling Time	$V_{CC} = 15\text{V}$ $C_L=1000\text{pF}$	T_f		30		ns
Output High Clamp Level	$V_{CC} = 18\text{V}$	V_{O_CLAMP}		11.5		V

PARAMETER	CONDITIONS	SYMBOL	MIN	TYP	MAX	UNITS
Oscillator for Switching Frequency						
CCM Frequency		F _{CCM}		100		kHz
Frequency Swapping	*	F _{SW_MOD}		±8		%
Green Mode Frequency		F _{SW_GREEN}		24		kHz
Temp. Stability	*	F _{SW_TS}		3	5	%
Voltage Stability	VCC =9V~24V *	F _{SW_VS}			1	%
Maximum Duty	*	D _{MAX}		81		%
Soft Start						
Soft Start Time	V _{CS_OFF} from 0.2V to 0.5V *	T _{SS}		7		ms
OLP (Over Load Protection)						
OLP Trip Level		V _{OLP}	2.65	2.8	2.95	V
OLP delay time	After soft-start	T _{D_OLP}		88		ms
Over Voltage Protection (CS Pin)						
CS OVP Trip Current Level		V _{CSOVP}	0.29	0.31	0.33	V
CS OVP De-bounce Cycle	*	T _{D_CS OVP}		8		Cycle
BNO Pin Auto Protection (BNO Pin)						
Brownout Turn-On Trip Level		V _{BNI}	1	1.05	1.1	V
Brownout Turn-Off Trip Level		V _{BNO}	0.9	0.95	1	V
BNO Pin De-bounce Time		T _{BNO}		75		ms
Internal OTP Protection						
OTP Level	*	T _{UP_OTP}		140		°C
OTP Hysteresis	*	T _{INOTP_HYS}		12		°C
SDSP (Secondary Diode Short Protection)						
SDSP CS Pin Level	Secondary diode short	V _{CS_SDSP}		1.2		V
De-bounce Cycle	*	T _{D_SDSP}		4		Cycle

*: Guaranteed by design.

Typical Performance Characteristic

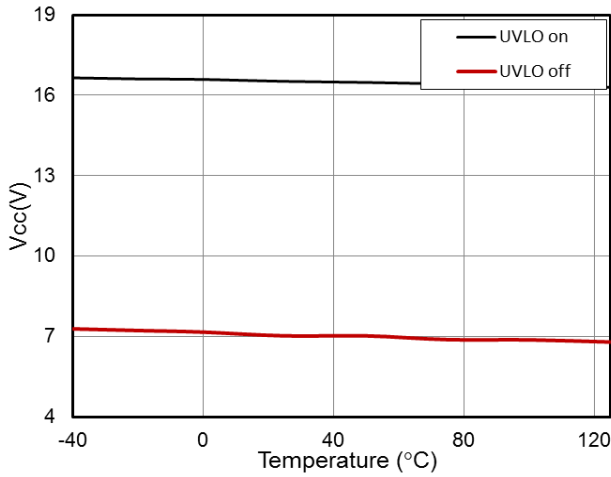

Fig. 1 UVLO Level vs. Temperature

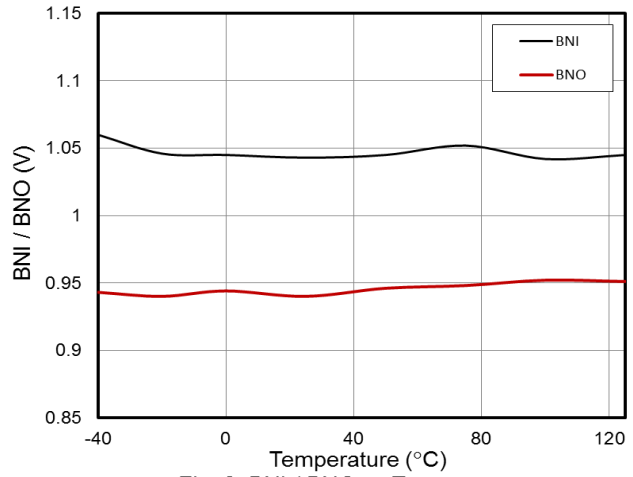

Fig. 2 BNI / BNO vs. Temperature

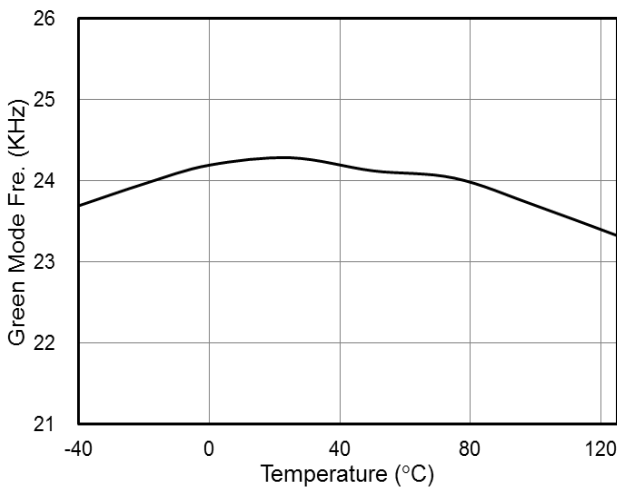

Fig. 3 Green Mode Fre. vs. Temperature

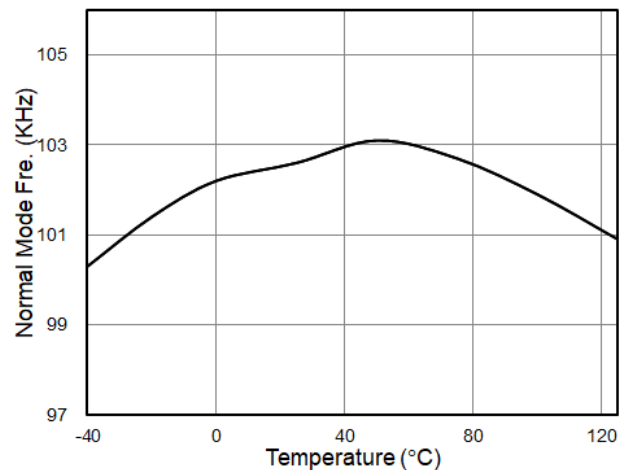

Fig. 4 Normal Mode Fre. vs. Temperature

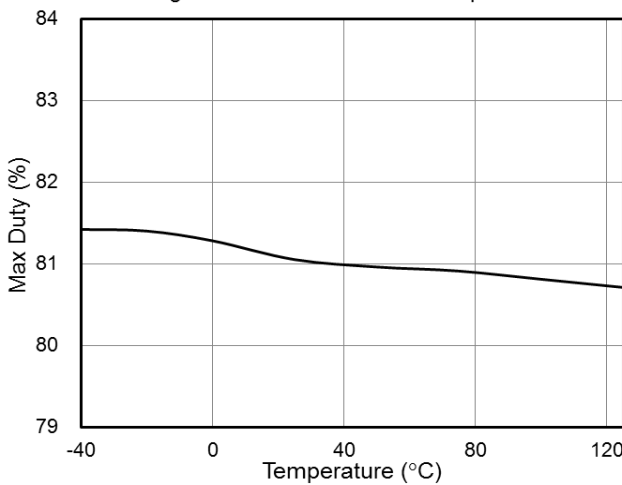

Fig. 5 Max Duty vs. Temperature

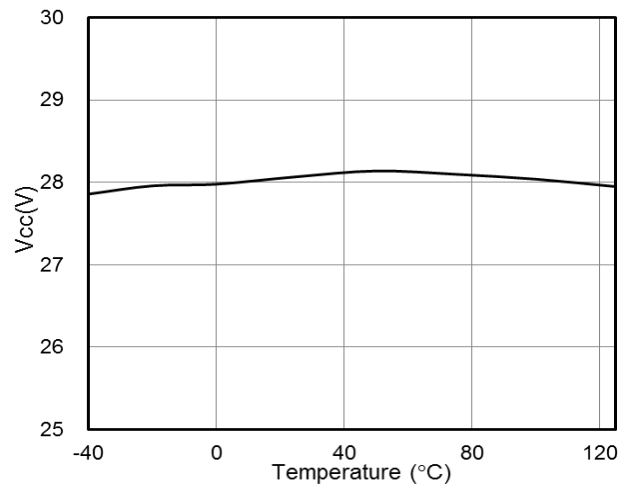

Fig. 6 Vcc OVP Level vs. Temperature

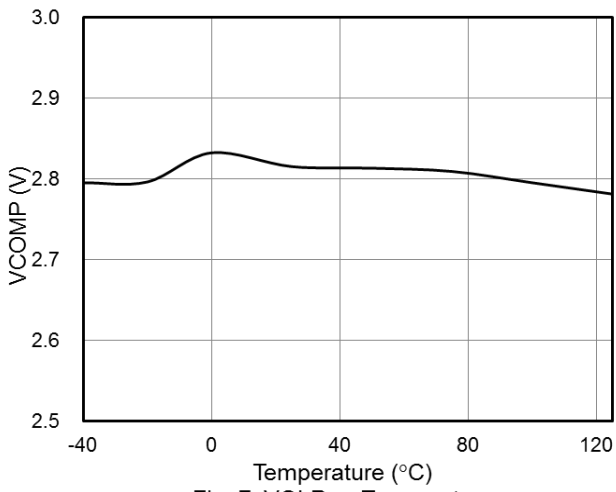

Fig. 7 VOLP vs. Temperature

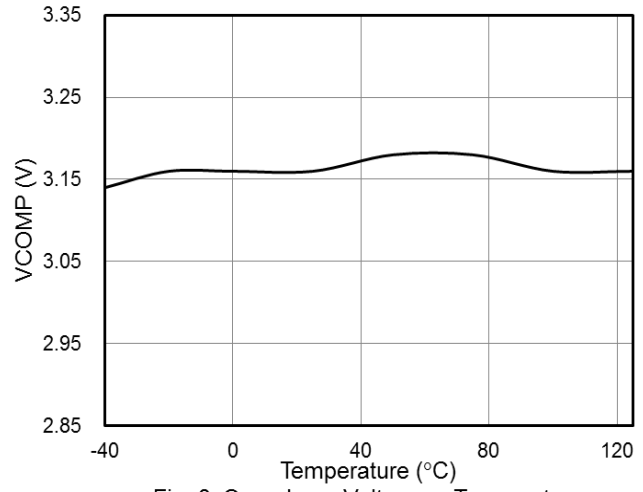

Fig. 8 Open Loop Voltage vs. Temperature

Application Information

Operation Overview

The LD5537B1/I1 meets the green-power requirement and is intended for the use in those modern switching power suppliers and adaptors which demand higher power efficiency and power-saving. It integrates more functions to reduce the external components counts and the size. Its major features are described as below.

Under Voltage Lockout (UVLO)

An UVLO comparator is implemented in it to detect the voltage on the VCC pin. It would assure the supply voltage enough to turn on the LD5537B1/I1 PWM controller and further to drive the power MOSFET. As shown in Fig. 9, a hysteresis is built in to prevent the shutdown from the voltage dip during startup.

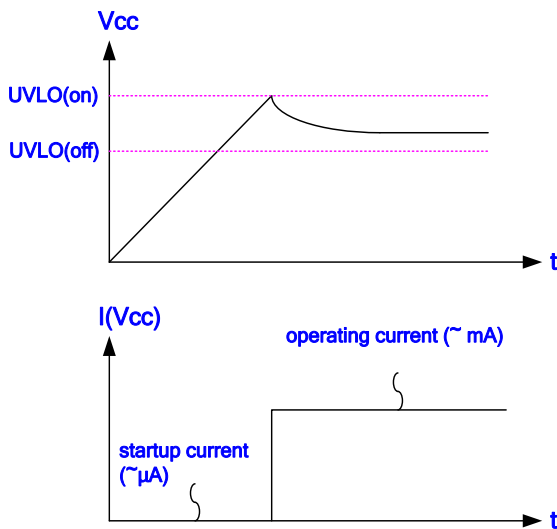

Fig. 9

Startup Current and Startup Circuit

The typical startup circuit to generate VCC of the LD5537B1/I1 is shown in Fig. 10. During the startup transient, the VCC is below UVLO threshold. Before it has sufficient voltage to develop OUT pulse to drive the power MOSFET, R1 will provide the startup current to charge the capacitor C1. Once VCC obtain enough voltage to turn on

the LD5537B1/I1 and further to deliver the gate drive signal, it will enable the auxiliary winding of the transformer to provide supply current. Lower startup current requirement on the PWM controller will help to increase the value of R1 and then reduce the power consumption on R1. By using CMOS process and the special circuit design, the maximum startup current for LD5537B1/I1 is only 3µA.

If a higher resistance value of the R1 is chosen, it will usually take more time to start up. To carefully select the value of R1 and C1 will optimize the power consumption and startup time.

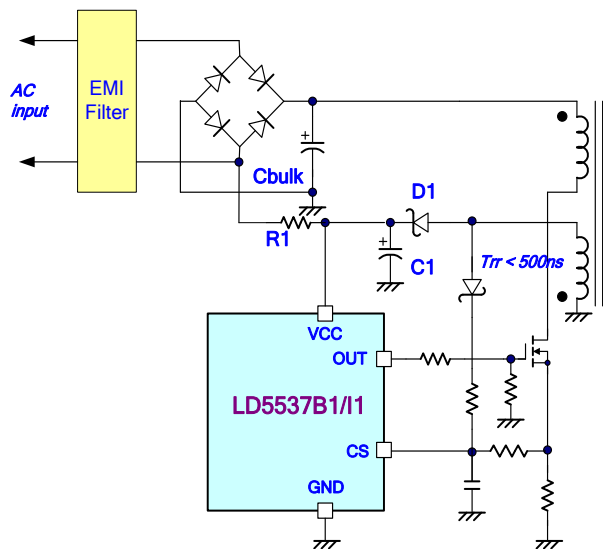

Fig. 10

Current Sensing and Leading-Edge Blanking

The typical current mode of PWM controller feedbacks both current signal and voltage signal to close the control loop and achieve regulation. The LD5537B1/I1 detect the primary MOSFET current from the CS pin, which is not only for the peak current mode control but also for the pulse-by-pulse current limit.

In general, the power converter will provide more current when input voltage alters to high due to the signal propagation delay. This can be compensated through LD5537B1/I1. It's controlled by varying the current limit

with the duty cycles in corresponding to V_{CS_OFF} . As shown in Fig. 11, V_{CS_OFF} (corresponding to current limit) is in direct proportion to duty ratio in a certain segment and is fixed at high or low if duty ratio is respectively over or below threshold values. As a result, the current limit will be lowered at high-line inputs. This compensation control mechanism is developed with patents pending by Leadtrend Technology.

The maximum voltage threshold of the current sensing pin is set at 0.815V for low-line input. Thus the MOSFET peak current can be calculated as:

$$I_{PEAK(MAX)} = \frac{0.815}{R_{CS}}$$

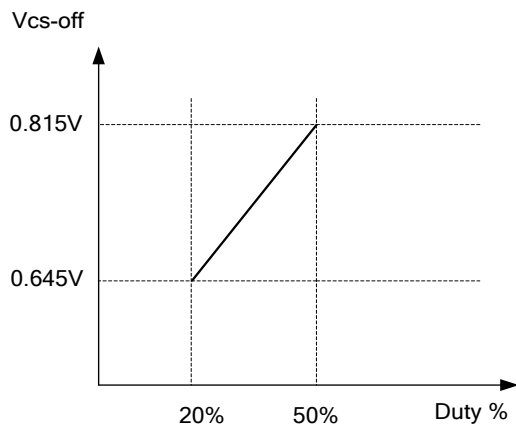

Fig. 11

A 200ns leading-edge blanking (LEB) time is included in the input of CS pin to prevent the false-trigger from the current spike. In the low power application, if the total pulse width of the turn-on spike is less than 200ns and the negative spike on the CS pin doesn't exceed -0.3V, it could remote the R-C filter (as shown in the Fig. 12).

However, the total pulse width of the turn-on spike is decided by the output power, circuit design and PCB layout. It is strongly recommended to adopt a smaller R-C filter (as shown in Fig. 13) for higher power application to avoid the CS pin being damaged by the negative turn-on spike.

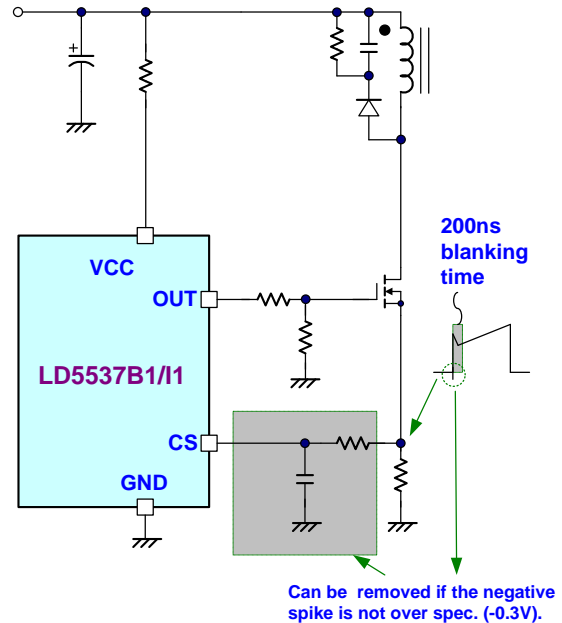

Fig. 12

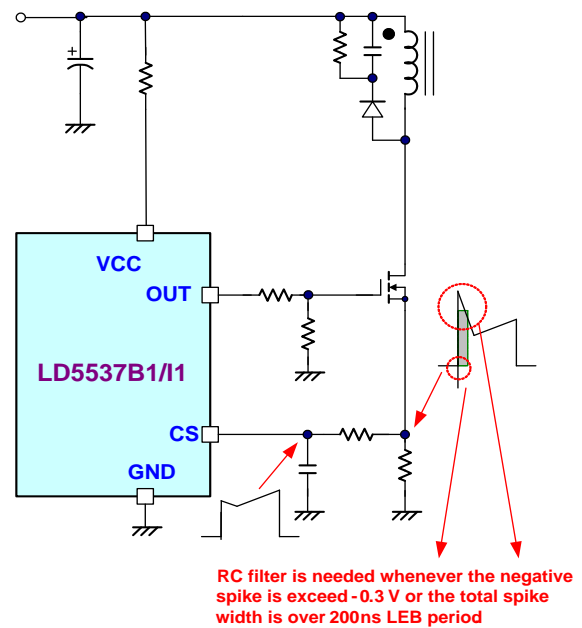

Fig. 13

Output Stage and Maximum Duty-Cycle

An output stage of a CMOS buffer, with typical 250/-500mA driving capability, is incorporated to drive a power MOSFET directly. And the maximum duty-cycle of LD5537B1/I1 is limited to 81% to avoid the transformer saturation.

Voltage Feedback Loop

The voltage feedback signal is provided from the TL431 at the secondary side through the photo-coupler to the COMP pin of the LD5537B1/I1. Similar to UC3842, the LD5537B1/I1 would carry a diode voltage offset at the stage to feed the voltage divider at the ratio of RA and RB, that is,

$$V_{-(PWM_{COMP_PARATOR})} = \frac{RB}{RA + RB} \times V_{COMP}$$

A pull-high resistor is embedded internally and can be eliminated externally.

Oscillator and Switching Frequency

The LD5537B1/I1 is implemented with frequency swapping function which helps the power supply designers to both optimize EMI performance and lower system cost. The switching frequency substantially centers at 100kHz, and swap between a range of ± 8 kHz.

Green-Mode Operation

By using the green-mode control, the switching frequency can be reduced under the light load condition. This feature helps to improve the efficiency in light load conditions. The green-mode control is Leadtrend Technology's own property. Fig. 14 shows the characteristics of the switching frequency vs. the COMP pin voltage (V_{COMP}).

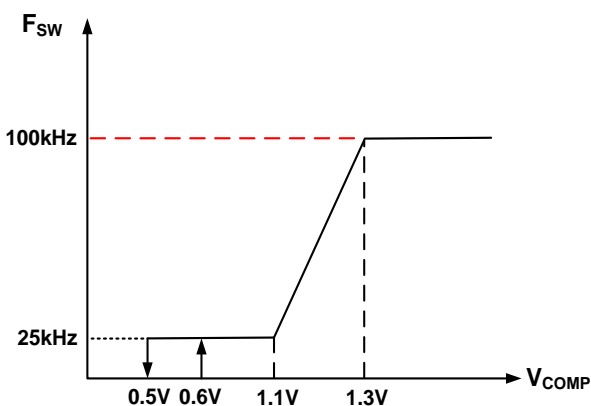

Fig. 14

On/Off Control

The LD5537B1/I1 can be turned off by pulling COMP pin lower than 0.5V. The gate output pin of the LD5537B1/I1 will be disabled immediately under such condition. The off-mode can be released when the pull-low signal is removed.

Internal Slope Compensation

In the conventional applications, the problem of the stability is a critical issue for current mode controlling, when it operates over 50% duty-cycle. As UC384X, It takes slope compensation from injecting the ramp signal of the RT/CT pin through a coupling capacitor. It therefore requires no extra design for the LD5537B1/I1 since it has integrated it already.

Output Short Circuit Protection (OSCP) – Auto Recovery for LD5537B1

The OSCP function can prevent the damage from output short circuit. Once the output is shorted, V_{out} and VCC drop immediately, which always reflects the auxiliary winding during the gate off region. According to the close loop control, COMP voltage will pull high in the meanwhile. If the V_{COMP} pulls higher than 2.8V over 15ms and VCC drops below 9.6V. At this time, the OSCP protection will be triggered and turn off the gate driving.

Over Load Protection (OLP) – Auto Recovery for LD5537B1

To protect the circuit from damage in over-load condition and short or open-loop condition, the LD5537B1/I1 is implemented with smart OLP function. LD5537B1 also features auto recovery function; see Fig. 15 for the waveform. In case of fault condition, the feedback system will force the voltage loop toward the saturation and then pull the voltage high on COMP pin (V_{COMP}). When the V_{COMP} ramps up to the OLP threshold of 2.8V and continues over OLP delay time, the protection will be activated and then turn off the gate output to stop the switching of power circuit.

With the protection mechanism, the average input power will be minimized to remain the component temperature and stress within the safe operating area.

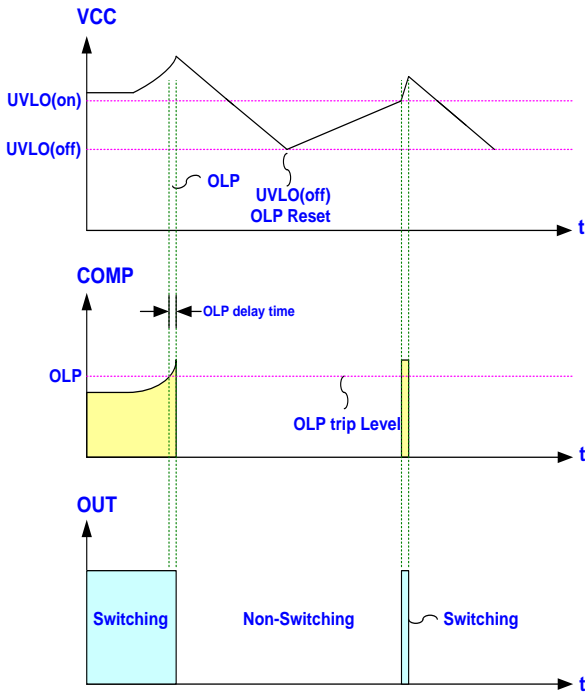

Fig. 15

Over Voltage Protection (OVP) on VCC Pin – Auto Recovery for LD5537B1

The V_{GS} ratings of the nowadays power MOSFETs are often limited up to max. 29V. To prevent the V_{GS} from the fault condition, LD5537B1/I1 is implemented with an OVP function on VCC. Whenever the VCC voltage is higher than the OVP threshold voltage, the output gate drive circuit will be shutdown simultaneously thus to stop the switching of the power MOSFET until the next UVLO(ON).

The VCC OVP function in LD5537B1 is an auto-recovery type protection. The Fig. 16 shows its operation.

On the other hand, if the OVP condition is removed, the VCC level will get back to normal level and the output will automatically return to the normal operation.

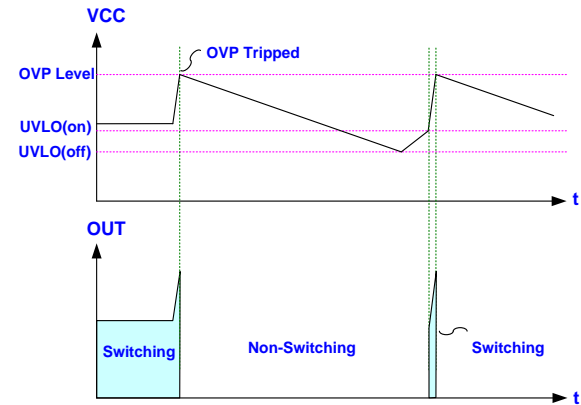

Fig. 16

Output Over Voltage Protection (CS OVP) on CS Pin – Auto Recovery for LD5537B1

An output overvoltage protection is implemented in the LD5537B1/I1, as shown in Fig. 17 and 18. It senses the auxiliary voltage via the divided resistors. The auxiliary winding voltage is reflected from secondary winding and therefore the flat voltage on the CS/OVP pin is proportional to the output voltage. LD5537B1/I1 can sample this flat voltage level after a delay time to perform output over voltage protection. This delay time is used to ignore the voltage ringing from leakage inductance of PWM transformer. The sampling voltage level is compared with internal threshold voltage 0.31V. If the sampling voltage exceeds the OVP trip level, an internal counter starts counting subsequent OVP events. The counter has been added to prevent incorrect OVP detection which might occur during ESD or lightning events. However, when typically 8 cycles of subsequent OVP events are detected, the OVP circuit switches the power MOSFET off.

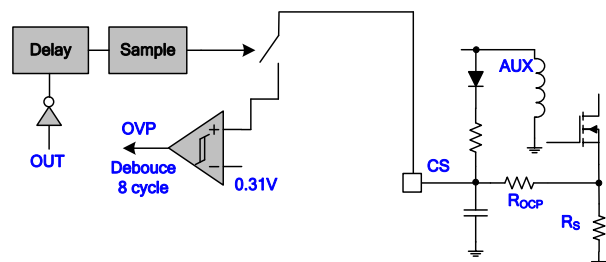

Fig. 17

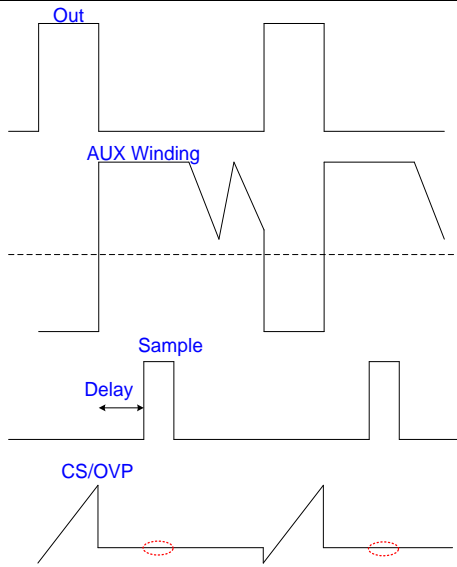

Fig. 18

Brown-out Protection (BNO)

The LD5537B1/I1 is programmable to set the brownout protection point through BNO pin. The voltage across the BNO pin is proportional to bridge rectifier of AC input. A brownout comparator is implemented to detect the abnormal line condition. As soon as the condition is detected, it will shut down the controller to prevent the damage. Fig. 19 shows the operation. When V_{BNO} falls below 0.95V, the gate output will remain off even V_{CC} has already achieved $UVLO(ON)$. It therefore makes V_{CC} hiccup between $UVLO(ON)$ and $UVLO(OFF)$. Unless the line voltage is enough to pull V_{BNO} larger than 1.05V, the gate output will not start switching even when the next $UVLO(ON)$ is tripped. A hysteresis is implemented to prevent the false trigger during turn-on and turn-off. LD5537B1/I1 can float this pin if haven't need BNO function.

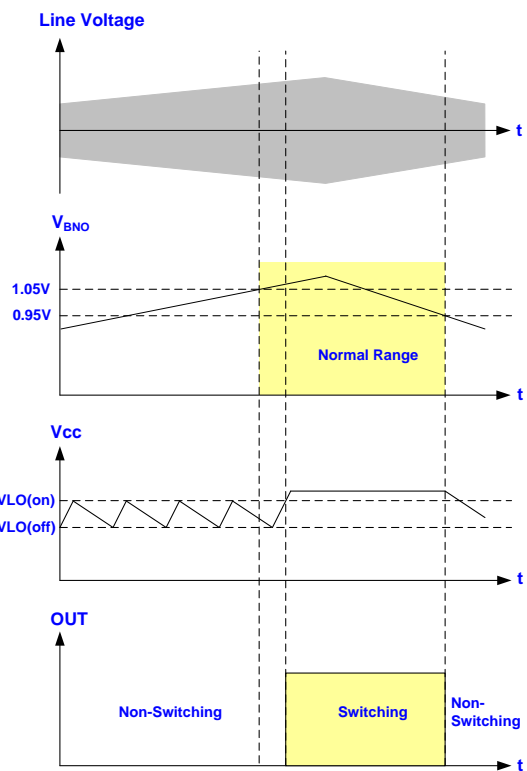

Fig. 19

Secondary Diode Short Protection (SDSP) – Auto Recovery for LD5537B1

The method that the LD5537B1/I1 judges the logic of SDSP is described briefly as follows. When V_{CS} is higher than 1.2V, it will reduce the frequency first, even the $T_{on} < T_{LEB} + T_{PD}$. When the count is up to 4 times, its gate will be turned-off, shown as Fig. 20.

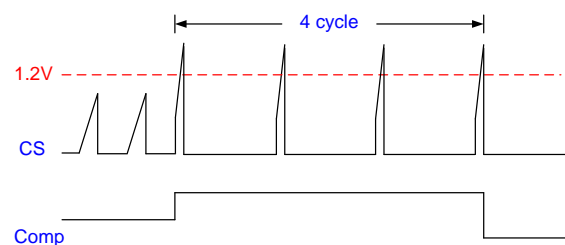

Fig. 20

Fault Protection

There are several critical protections integrated in the LD5537B1/I1 to prevent from damage to the power supply. Those damages usually come from open or short conditions on the pins of LD5537B1/I1.

In case under such conditions listed below, the gate output will turn off immediately to protect the power circuit.

1. CS pin floating
2. COMP pin floating

Package Information

SOT-26

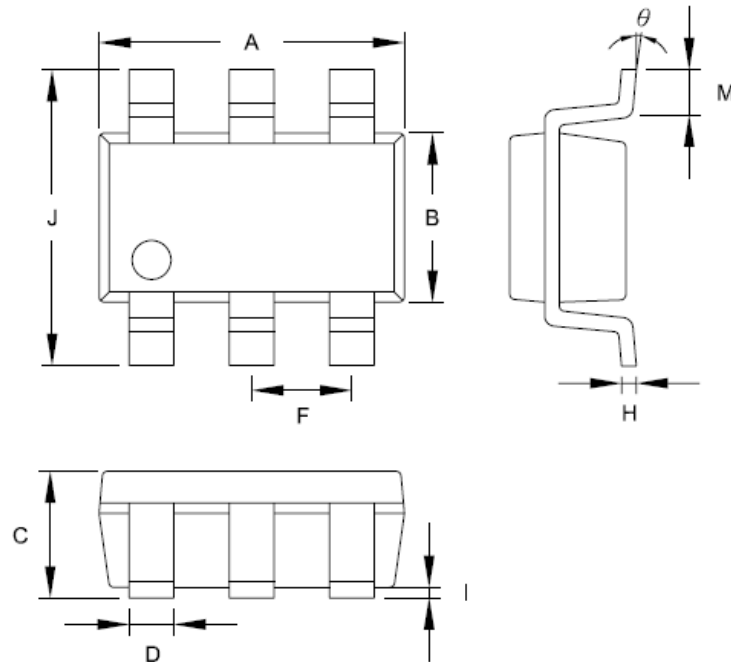

Symbol	Dimension in Millimeters		Dimensions in Inches	
	Min	Max	Min	Max
A	2.692	3.099	0.106	0.122
B	1.397	1.803	0.055	0.071
C	-----	1.450	-----	0.057
D	0.300	0.500	0.012	0.020
F	0.95 TYP		0.037 TYP	
H	0.080	0.254	0.003	0.010
I	0.050	0.150	0.002	0.006
J	2.600	3.000	0.102	0.118
M	0.300	0.600	0.012	0.024
θ	0°	10°	0°	10°

Important Notice

Leadtrend Technology Corp. reserves the right to make changes or corrections to its products at any time without notice. Customers should verify the datasheets are current and complete before placing order.

Revision History

REV.	Date	Change Notice
00	12/18/2018	Original Specification