

## High Voltage Multi-Mode PWM Controller with BNO Function

REV: 00

### General Description

The LD5762K is a green mode PWM IC built-in with brown-in/ out functions in a SOP-7 package. The device could therefore minimize the component counts, circuit space, and reduces the overall material cost of power applications.

The LD5762K features HV start, sleep-mode, green-mode power-saving operation, and internal slope compensation, Soft-start functions which could minimum the power loss and improve the system performance.

With complete protection with it, like OPP (Over Power Protection), OVP (Over Voltage Protection), OCP (Over Current protection), brown-in/out protection and bulk cap. OVP, LD5762K prevents the circuit from being damaged in abnormal conditions.

Furthermore, the LD5762K features frequency swapping and soft driving function to minimize the noise and improve EMI.

### Features

- Secondary-side feedback control with quasi-resonant + CCM operation
- High-Voltage (710V) Startup Circuit
- Built-in Brown-in/out Function on HV pin
- Built-in X-Cap Discharge on HV pin
- OVP (Over Voltage Protection) on VCC/FB
- OPP (Over Power Protection)
- OCP (Over Current Protection)
- OSCP(Output Short Circuit Protection)
- Adj. CS\_OTP (Over Temperature Protection)
- Bulk Cap. OVP
- Peak Load FSW Boost
- Soft Driving
- +300mA/-800mA Driving Capability

### Applications

- Printer

### Typical Application

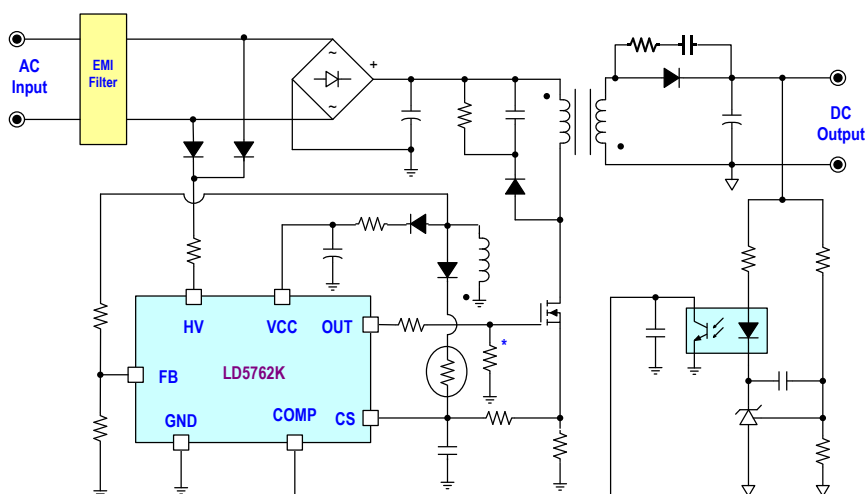

## Pin Configuration

SOP-7 (TOP VIEW)



YY: Year code  
 WW: Week code  
 PP: Production code

## Ordering Information

Part number	Package	Top Mark	Shipping
LD5762K GR	SOP-7	LD5762KGR	2500/tape & reel

The LD5762K is RoHs compliant/ green packaged.

## Protection Mode

Part number	VCC_OVP	OSCP	CS_OTP	OPP	FB_UVP	FB_OVP
LD5762K	Auto	Auto	Auto	Auto	Auto	Auto

## Pin Descriptions

PIN	NAME	FUNCTION
1	FB	Auxiliary voltage sense, output voltage protection and quasi resonant detection.
2	COMP	Voltage feedback pin. Connect a photo-coupler with it to close the control loop and achieve the regulation.
3	CS	Current sense pin, connect it to sense the MOSFET current
4	GND	Ground
5	OUT	Gate drive output to drive the external MOSFET
6	VCC	Supply voltage pin
7	NC	Unconnected Pin
8	HV	<p>Connect this pin to Line/ Neutral of AC main voltage through resistor to provide the startup current for the controller. When VCC voltage increase to trip the point of UVLO(on), this HV loop will be turned off to reduce the power loss on the startup circuit.</p> <p>An internal resistor divider between HV to GND pin will monitor AC line voltage to activate Brown-in/out function control.</p>

**Block Diagram**

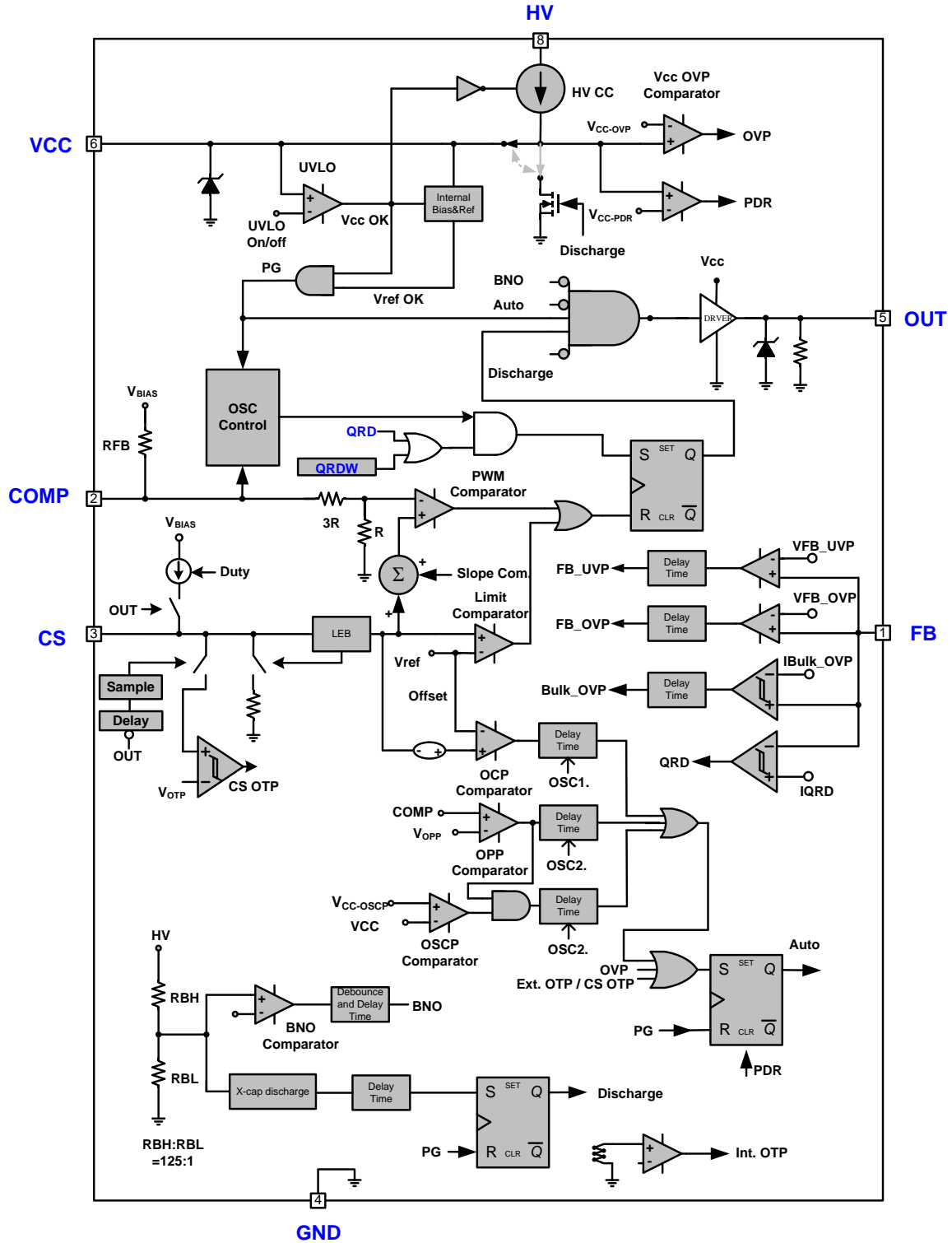

## Absolute Maximum Ratings

Supply Voltage VCC.....	-0.3V~33V
HV.....	-0.3V~710V
COMP, FB, CS.....	-0.3V~6V
OUT.....	-0.3V~VCC+0.3V
Maximum Junction Temperature.....	150°C
Storage Temperature Range.....	-65°C to 150°C
Package Thermal Resistance (SOP-7) .....	160°C/W
Power Dissipation (SOP-7, at Ambient Temperature = 85°C).....	250mW
Lead temperature (Soldering, 10sec).....	260°C
ESD Voltage Protection, Human Body Model (except of HV Pin).....	2.5kV
ESD Voltage Protection, Machine Model (except of HV Pin).....	250V
ESD Voltage Protection, Human Body Model (HV Pin).....	1kV
ESD Voltage Protection, Machine Model (HV pin).....	200V
Gate Output Current.....	+300/-800mA

### Caution:

Stress exceeding maximum ratings may damage the device. Maximum ratings are stress ratings only. Functional operation above the recommended operating conditions is not implied. Extended exposure to stress above recommended operating conditions may affect device reliability.

## Recommended Operating Conditions

Item	Min.	Max.	Unit
Operating Junction Temperature	-40	125	°C
Supply VCC Voltage	8.5	26.5	V
HV resistor Value (AC Side)	8	17.5	kΩ
HV to GND Capacitor Value	--	300	pF
Comp Pin Capacitor	1	10	nF
CS Pin Capacitor Value	47	390	pF

## Electrical Characteristics

(T<sub>A</sub> = +25°C unless otherwise stated, VCC=15.0V)

PARAMETER	CONDITIONS	SYMBOL	MIN	TYP	MAX	UNITS
<b>High-Voltage Supply (HV Pin)</b>						
High-Voltage Current Source	VCC < UVLO <sub>(ON)</sub> , HV=500V	I <sub>HV</sub>	2	2.8	3.5	mA
HV Discharge capability	HV=500V	I <sub>HV_DIS</sub>	2	2.5	3.5	mA
HV Pin Total Input Current (HV+ BNO)	HV=500 V <sub>DC</sub> , VCC > UVLO <sub>(ON)</sub> ,	I <sub>HV_LEAK</sub>			35	μA
HV Pin Brown-In Level (HVBI)	HV pin = half rectifier wave increase	V <sub>HVBI</sub>	95	105	115	V <sub>DC</sub>
HV Pin Brown-out Level (HVBO)	HV pin = half rectifier wave decrease	V <sub>HVBO</sub>	78	88	98	V <sub>DC</sub>
HV Pin BNO Hysteresis	HV <sub>BI</sub> -HV <sub>BO</sub>	ΔV <sub>HV</sub>	9	17	25	V <sub>DC</sub>
Brown-in De-bounce Time	V <sub>COMP</sub> =3V	T <sub>D_HVBI</sub>	200	400	550	μs
Brown-out Detection Delay time	V <sub>COMP</sub> =3V	T <sub>D_HVBO</sub>		80		ms
HV Pin Min. Operation Voltage	VCC=15V (DetV <sub>min</sub> = V <sub>HV</sub> -VCC = 30V)	V <sub>HV_MIN</sub>	45			V
X-Cap discharge Detection Delay time	V <sub>COMP</sub> =3V	T <sub>D_XCAP</sub>	55	70	85	ms
<b>Supply Voltage (VCC Pin)</b>						
Startup Current	VCC=15V ,HV=500V	I <sub>CC_ST</sub>		25	50	μA
Operating Current (with 1nF load on OUT pin)	V <sub>COMP</sub> =3V	I <sub>CC_OP1</sub>		2		mA
	V <sub>COMP</sub> =0V	I <sub>CC_OP2</sub>		0.33		mA
	Auto mode	I <sub>CC_OPR</sub>		0.28		mA
UVLO <sub>(OFF)</sub>		V <sub>CC_OFF</sub>	5.5	6	6.5	V
UVLO <sub>(ON)</sub>		V <sub>CC_ON</sub>	15	16	17	V
VCC HVBI Level	HV > HVBI (Fig 1.)	V <sub>CC_HVBI</sub>		UVLO <sub>(OFF)</sub> +4V		V
VCC OVP Level		V <sub>CC_OVP</sub>	31	32	33	V
VCC OVP De-bounce Time	V <sub>COMP</sub> =3V	T <sub>D_VCCOVP</sub>		120		μs

PARAMETER	CONDITIONS	SYMBOL	MIN	TYP	MAX	UNITS
<b>Oscillator for Switching Frequency</b>						
Frequency	V <sub>COMP</sub> =4.4V V <sub>HV</sub> >250V <sub>DC</sub>	F <sub>SW_N</sub>	61	65	69	kHz
	V <sub>COMP</sub> =4.4V V <sub>HV</sub> <250V <sub>DC</sub>	F <sub>SW_H</sub>	115	130	140	kHz
Green Mode Frequency	V <sub>COMP</sub> =1.3V	F <sub>SW_GREEN</sub>	22	25	28	kHz
Trembling Frequency	Frequency= 25kHz	F <sub>TRM1</sub>		±4		kHz
	Frequency= 65kHz	F <sub>TRM2</sub>		±6		kHz
	Frequency=130kHz	F <sub>TRM3</sub>		±10		kHz
Modulation Frequency	* Frequency= 65kHz	F <sub>SW_MOD</sub>		200		Hz
F <sub>SW</sub> Temp. Stability	*-40°C ~105°C	F <sub>SW_TS</sub>	0	3	4	%
F <sub>SW</sub> Voltage Stability	*V <sub>CC</sub> =8V-(OVP-1V)	F <sub>SW_VS</sub>	0		1	%
Maximum On Time		D <sub>MAX</sub>	78	83	88	%
<b>OSCP (Output Short Circuit Protection)</b>						
OSCP Trip Level		V <sub>CC_OSCP</sub>		UVL <sub>O</sub> OFF +4V		V
OSCP Delay Time		T <sub>D_OSCP</sub>			10	ms
<b>Voltage Feedback (Comp Pin)</b>						
Input Voltage to Current-Sense Attenuation	*	A <sub>V</sub>		1/4.0		V/V
Comp Impedance		Z <sub>COMP</sub>		42		kΩ
Open Loop Voltage	COMP pin open	V <sub>COMP_OPEN</sub>	4.9	5.2	5.5	V
OPP Tripped Level	TC: track COMP pin open voltage	V <sub>OPP</sub>	4.4	4.6	4.8	V
Peak Mode Threshold V <sub>COMP</sub>		V <sub>P2</sub>	4.15	4.35	4.55	V
Peak Mode Down Threshold	(Fig 1.)	V <sub>G2</sub>	3.85	4.05	4.25	V
PWM Mode Threshold V <sub>COMP</sub>	0.9 of F <sub>SW-N</sub> ,	V <sub>P1</sub>	2.35	2.55	2.75	V
Green Mode Threshold V <sub>COMP</sub>	1.1 of F <sub>SW-GREEN</sub> ,	V <sub>G1</sub>	2.05	2.25	2.45	V
Zero Duty Threshold V <sub>COMP</sub> on Burst mode	Zero Duty	V <sub>ZDC</sub>	1.0	1.1	1.2	V
	Hysteresis	V <sub>ZDCH</sub>		110		mV

PARAMETER	CONDITIONS	SYMBOL	MIN	TYP	MAX	UNITS
<b>Current Sensing (CS Pin)</b>						
Limit Voltage	Vsetting<0.15V	V <sub>CS_MAX1</sub>	0.685	0.725	0.765	V
	Vsetting>0.15V	V <sub>CS_MAX2</sub>	0.635	0.675	0.715	V
OCP Voltage		V <sub>CS_OCP</sub>	0.5	0.535	0.57	V
OCP Delay Time		T <sub>D_OCP</sub>	3.5	4.5	5.5	S
OCP Reset Time		T <sub>D_OCPRS</sub>		15		ms
Leading Edge Blanking Time		T <sub>LEB</sub>		360		ns
Delay to Output		T <sub>PD</sub>		80		ns
Slope Compensation Level	*	V <sub>SLP_L</sub>	0		0.156	V
Slope Compensation Position	*	V <sub>SLP</sub>	0		83	%
<b>Gate Drive Output (OUT Pin)</b>						
Output Low Level	VCC=15V, I <sub>o</sub> =20mA	V <sub>OL</sub>	0		1	V
Output High Level	VCC=15V, I <sub>o</sub> =20mA	V <sub>OH</sub>	8		VCC	V
Rising Time	Load Capacitance=1000pF	T <sub>r</sub>		90		ns
Falling Time	Load Capacitance=1000pF	T <sub>f</sub>		20		ns
OUT Pin Clamping Voltage	VCC= 21V, 1nF on OUT pin	V <sub>O_CLAMP</sub>		12		V
<b>OPP (Over Power Protection)</b>						
OPP Delay Time		T <sub>D_OPP</sub>	260	320	380	ms
OPP Reset Time		T <sub>D_OPPRS</sub>		15		ms

PARAMETER	CONDITIONS	SYMBOL	MIN	TYP	MAX	UNITS
<b>QRD (Quasi Resonant Detection, FB Pin)</b>						
UVP Trip voltage Level		$V_{FB\_UVP}$	0.45	0.5	0.55	V
De-bounce Cycle		$T_{SKIP}$		1		Cycle
FB UVP De-bounce Time		$T_{FB\_UVP}$		2.5		ms
OVP Trip voltage Level		$V_{FB\_OVP}$	2.85	3	3.15	V
De-bounce Cycle		$T_{D\_FBOVP}$		8		Cycle
Bulk Cap OVP		$I_{BULK\_OVP}$	335	370	405	$\mu A$
Bulk Cap OVP delay		$T_{BULK\_OVP}$		480		ms
QRD Trip Level	*	$I_{QRD}$		20		$\mu A$
QRD Delay Time	*	$T_{QRD}$		100		ns
<b>Soft Start</b>						
Soft Start Duration(1)	After OPP, OCP, OTP, BNO, OVP is tripped	$T_{SS1}$		6		ms
Soft Start Duration(2)	*Fsw=65kHz	$T_{SS2}$	30			ms
<b>Internal OTP</b>						
OTP Tripped Level( $T_{OTP}$ )	*	$T_{INOTP}$		140		$^{\circ}C$
OTP Hysteresis	*	$T_{INOTP\_HYS}$		$T_{OTP}-30$		$^{\circ}C$
OTP De-bounce Time	*	$T_{D\_INOTP}$		50		$\mu s$
<b>CS_OTP (Over Temperature Protection Protection)</b>						
OTP Trip Current Level		$V_{CSOTP}$	0.27	0.3	0.33	V
VCS Discharge Time	*Gate On (Ron=100ohm)	$T_{DIS\_CS}$		LEB		ns
CS OTP De-bounce Time		$T_{D\_CSOTP}$		16		cycle

\*: Guaranteed by design.

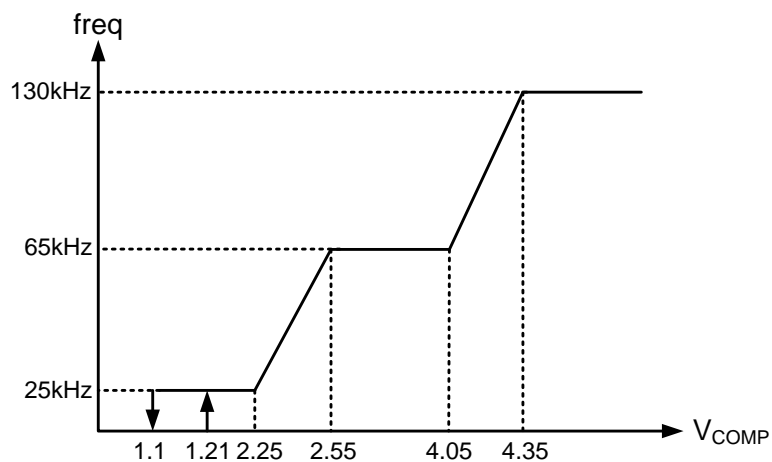

Fig. 1  $V_{COMP}$  vs. PWM Frequency



## Typical Performance Characteristics

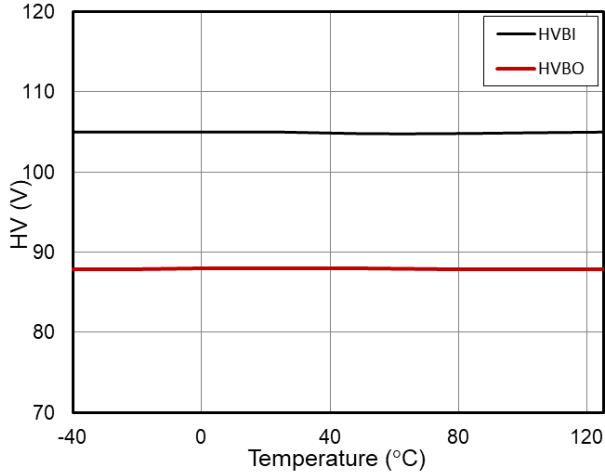

Fig. 2 HVBI/HVBO Level vs. Temperature

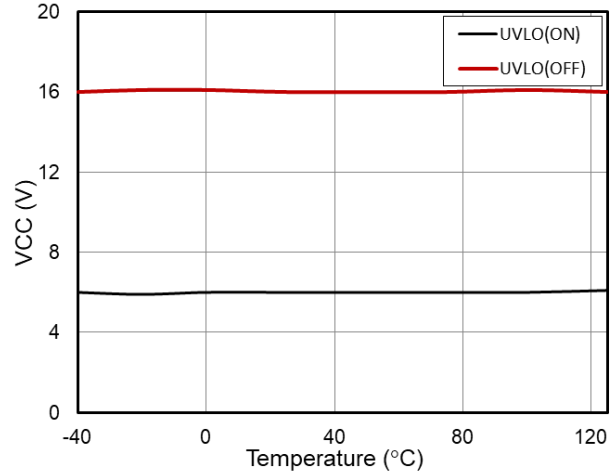

Fig. 3 UVLO vs. Temperature

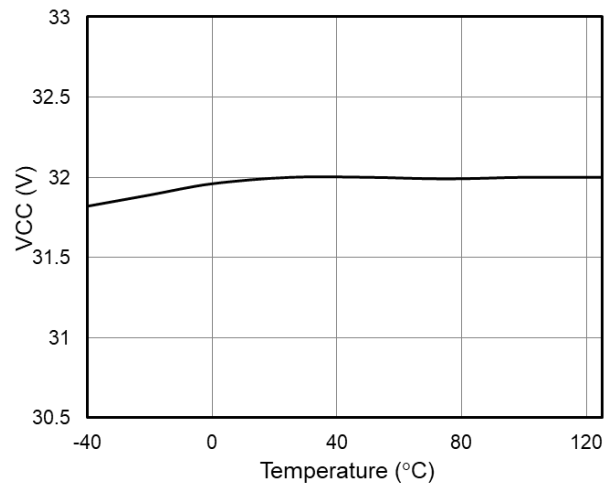

Fig. 4 VCC OVP vs. Temperature

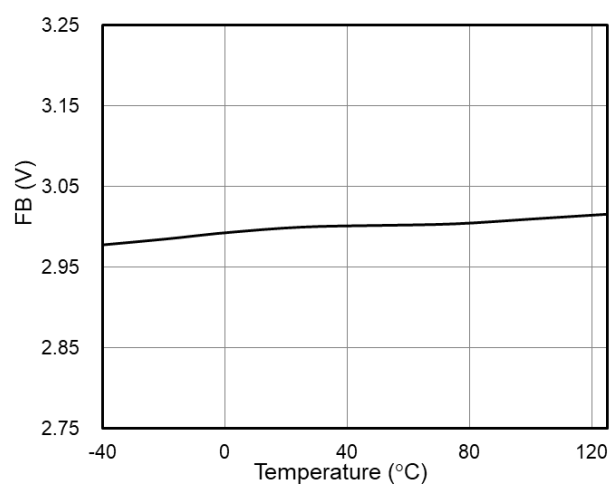

Fig. 5 FB OVP vs. Temperature

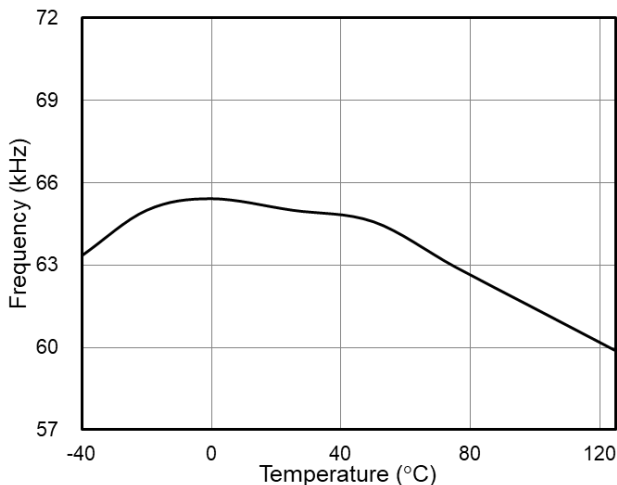

Fig. 6 Normal Mode Fre. vs. Temperature

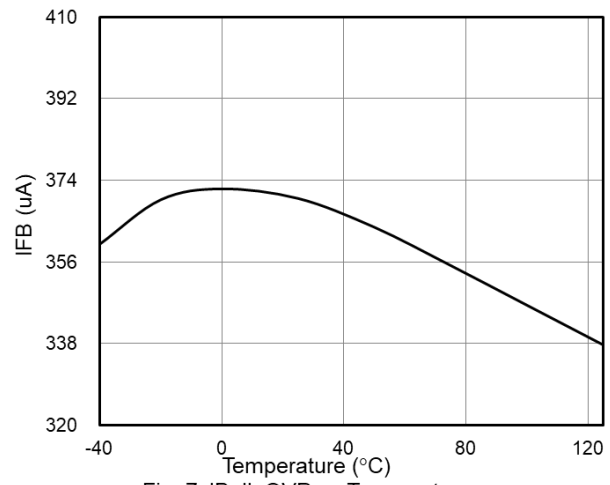

Fig. 7 IBulk OVP. vs. Temperature

## Application Information

### Operation Overview

As long as the green power requirement becomes a trend and the power saving is getting more and more important for the switching power supplies and switching adaptors, the traditional PWM controllers are not able to support such new requirements. Furthermore, the cost and size limitation force the PWM controllers to be more powerful and with more functions to reduce the external part counts. The LD5762K is ideal for these applications. Its detailed features are described as below.

### Internal High-Voltage Startup Circuit and Under Voltage Lockout (UVLO)

The traditional circuit provides the startup current through a startup resistor to power up the PWM controller. However, it consumes much significant power to meet the current power saving requirement. In most cases, startup resistors carry larger resistance and spend more time to start up.

To achieve the optimized topology, as shown in Fig. 8, LD5762K is implemented with a high-voltage startup circuit for such requirement. At startup, the high-voltage current source sinks current of AC Line/or Neutral to provide startup current and charge the capacitor connected to VCC.

During the startup transient, the HV current will supply around 2.8mA to VCC capacitor until this VCC voltage reaches the UVLO threshold VCC. By using such configuration, the turn-on delay time will be almost same no matter under low-line or high-line conditions.

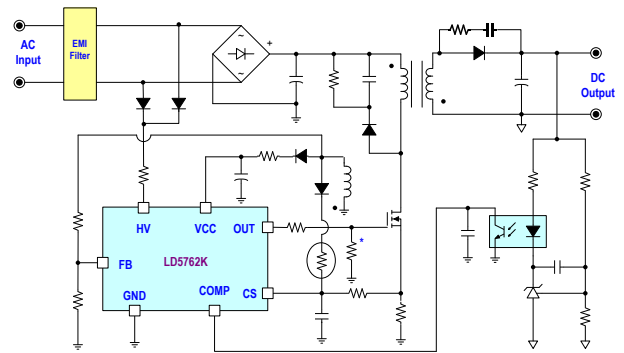

Fig. 8

As VCC trips UVLO(off), HV pin will recharge VCC capacitor till VCC voltage rises back to UVLO(on) again. Since then, HV pin would no longer charge the capacitor and instead, send a gate drive signal to draw supply current for VCC from the auxiliary winding of the transformer. That minimizes the power loss on the start-up circuit successfully.

An UVLO comparator is embedded to detect the voltage across the VCC pin to ensure the supply voltage enough to power on the LD5762K and in addition, to drive the power MOSFET. As shown in Fig. 9, a hysteresis is provided to prevent shutdown from the voltage dip during startup. The turn-on and turn-off threshold level are set at 16V and 6V, respectively.

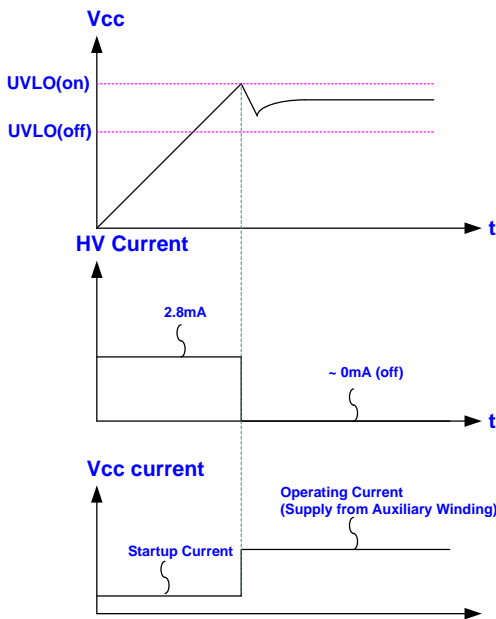

Fig. 9

### QR Mode Detection

The transformer will be demagnetized after the main power MOSFET turns off. A quasi resonant signal will be detected from auxiliary winding by FB pin through the external resistor.

As soon as the current of the secondary side diode is down to zero during MOSFET-off period, the transformer's core is demagnetized completely.  $V_{DS}$  of MOSFET will resonate in discontinuous current mode. The resonance frequency ( $F_{QR}$ ) will be obtained as below.

$$F_{QR} = \frac{1}{2\pi\sqrt{L_M \times C_R}} \text{ (Hz)}$$

$L_M$  = Inductance of primary winding

$C_R$  = Resonance equivalent parasitic capacitance

If  $V_{DS}$  voltage falls to resonant valley level from max plateau value, the QRD comparator will be tripped while FB pin current is close to  $20\mu\text{A}$ .

### Brown in/out Protection

The LD5762K features brown-in/out function on HV pin. As the built-in comparator detects the half wave rectify line voltage condition, it will shut off the controller to prevent from any damage. Fig. 10 shows the operation. When  $V_{HV} < HVBO$ , the gate output will remain off even when the VCC already reaches UVLO(ON). It therefore forces the VCC hiccup between UVLO(ON) and UVLO(OFF). Unless the line voltage rises over HVBI  $V_{AC}$ , the gate output will not start switching even as the next UVLO(ON) is tripped. A hysteresis is implemented to prevent the false-triggering during turn-on and turn-off.

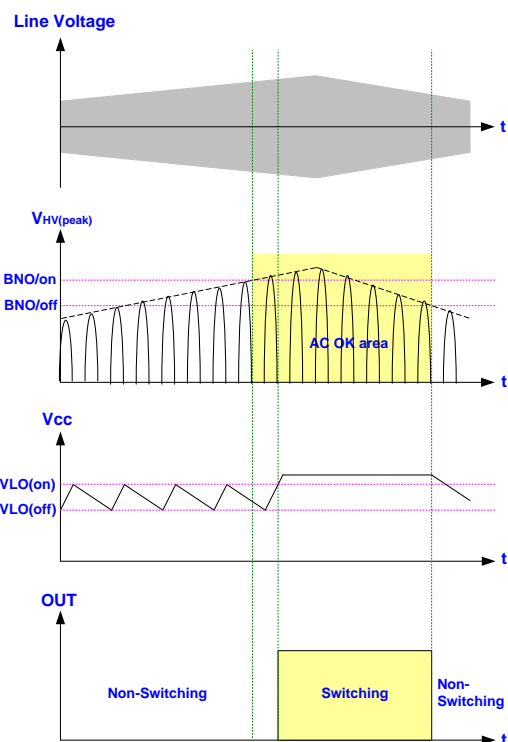

Fig. 10

## Current Sensing, Leading-Edge Blanking and the Negative Spike on CS Pin

The typical current mode PWM controller feeds back both current signal and voltage signal to close the control loop and achieve regulation. The LD5762K detects the primary MOSFET current across CS pin to control in peak current mode and also limit the pulse-by-pulse current. The maximum voltage threshold of the current sensing pin is 0.725V ( $V_{setting} < 0.15V$ ) or 0.675V ( $V_{setting} > 0.15V$ ). Thus the MOSFET peak current can be calculated as:

$$I_{PEAK(MAX)} = \frac{0.725V}{R_S} \quad (V_{setting} < 0.15V)$$

or

$$I_{PEAK(MAX)} = \frac{0.675V}{R_S} \quad (V_{setting} > 0.15V)$$

A 360ns leading-edge blanking (LEB) time is designed in the input of CS pin to prevent false-triggering from the current spike. In the low power applications, if the total pulse width of the turn-on spikes is less than 250ns and the negative spike on the CS pin does not exceed -0.3V, the R-C filter (as shown in Fig. 11) is free to eliminate.

However, the total pulse width of the turn-on spike is related to the output power, circuit design and PCB layout. It is strongly recommended to add a small R-C filter (as shown in Fig. 12) for larger power application to avoid the CS pin from being damaged by the negative turn-on spike.

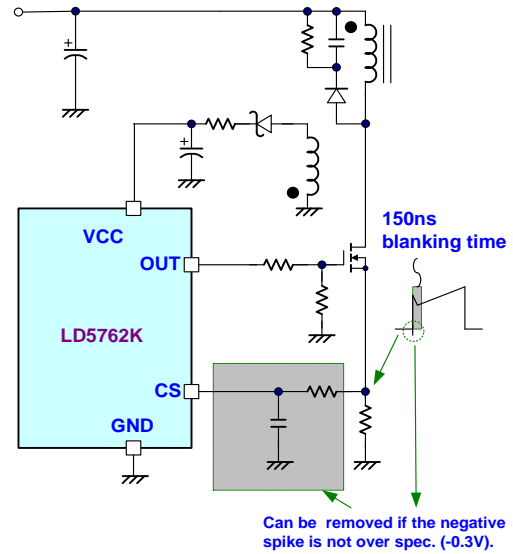

Fig. 11

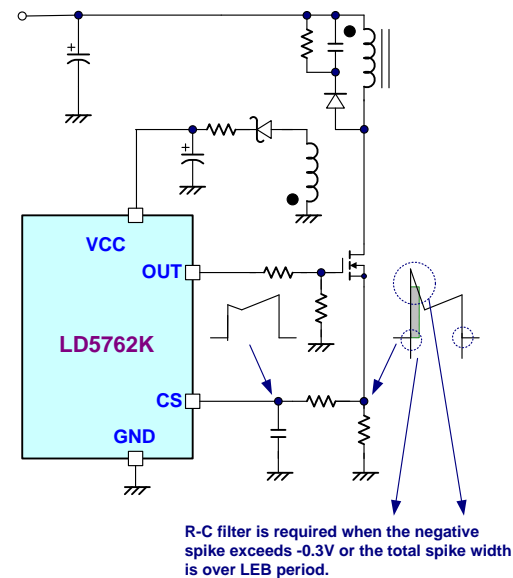

Fig. 12

## Output Stage and Maximum Duty-Cycle

An output stage of a CMOS buffer with typical 300mA driving capability is incorporated to drive a power MOSFET directly. And the maximum duty-cycle of LD5762K is limited to 83% to avoid the transformer saturation.

## Voltage Feedback Loop

The voltage feedback signal is provided from the TL431 on the secondary side through the photo-coupler to the COMP pin of LD5762K. Similar to UC384X, its input stage is with 1 diodes voltage offset to feed the voltage divider with 1/4 ratio, that is,

$$V_{CS}(\text{PWM}_{\text{COMPARATOR}}) = \frac{1}{4} * V_{\text{COMP}}$$

A pull-high resistor is embedded internally to optimize the external circuit.

## Internal Slope Compensation

A fundamental issue of current mode control is the stability problem when its duty-cycle is operated for more than 50%. To stabilize the control loop, the slope compensation is required in the traditional UC384X design by injecting the ramp signal from the RT/CT pin through a coupling capacitor. LD5762K has internal slope compensation circuit to simplify the external circuit design.

## Oscillator and Switching Frequency

The LD5762K has the switching frequency between 65 kHz  $\pm$  6kHz internally to optimize its performance in EMI, thermal treatment, component sizes and transformer design.

## Dual-Oscillator Green-Mode Operation

There are many different topologies has been implemented in different chips for the green-mode or power saving requirements such as “burst-mode control”, “skipping-cycle mode”, “variable off-time control” ...etc. The basic operation theory of all these approaches intended to reduce the switching cycles under light-load or no-load condition either by skipping some switching pulses or reduce the switching frequency.

By using LD proprietary dual-oscillator technique, the green-mode frequency can be well controlled and further to avoid the generation of audible noise.

## On/Off Control

Pulling COMP pin below  $V_{ZDC}$  will immediately disable the gate output of LD5762K. Remove the pull-low signal to reset it.

## Over Power Protection (OPP) - Auto Mode

The LD5762K features auto mode of smart OPP protection. Fig. 13 shows the waveform under fault condition. The feedback system will force the voltage loop toward the saturation and thus pull the voltage high across COMP pin (VCOMP). When the VCOMP ramps up to the OPP threshold of 4.6V and stays for longer than OPP delay time, the protection will be activated and then turn off the gate output to stop the switching of power circuit. The delay time is to prevent the false-triggering during power-on, turn-off transient and in peak load condition. As soon as the over load condition is removed, the controller will auto recovery when the VCC reaches  $UVLO(ON)$ .

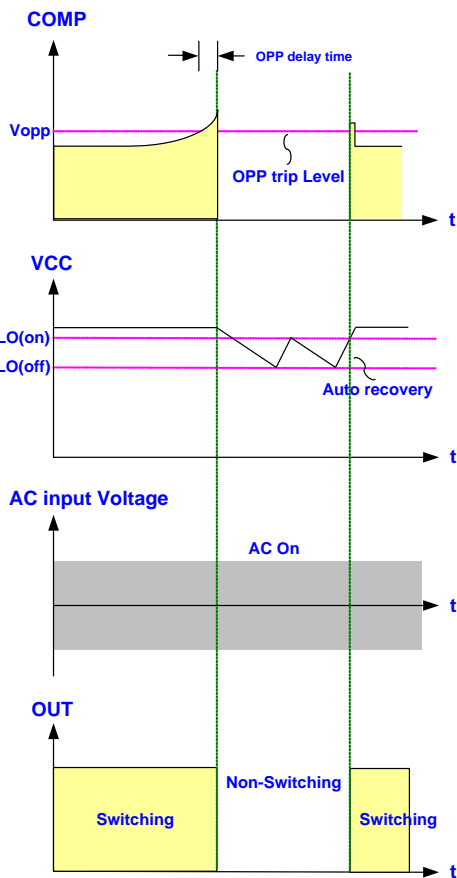

Fig. 13

## Over Current Protection (OCP) – Auto Mode

When the switching current is higher than the OCP threshold, the internal counter counts up. When the total accumulated counting time is more than OCP delay time, the controller triggers the OCP. This protection is auto mode function.

## Under Voltage Protection on FB (FB\_UVP) - Auto Mode

In order to prevent output short situation, LD5762K is implemented by FB\_UVP. When the output load is shorted to ground, the voltage suddenly decreases to zero, which always reflects to auxiliary winding during the gate off region. Therefore, as VFB is lower than 0.5V

& VCOMP > 4.6V during gate off region, the FB\_UVP is triggered. And when the condition is maintained for 2.5ms, LD5762K is in auto mode.

## Over Voltage Protection on VCC (OVP) – Auto Mode

The VGS ratings of the nowadays power MOSFETs are mostly with 32V maximum. To protect the VGS from the fault condition, LD5762K is implemented with OVP function on VCC. As the VCC voltage is larger than the OVP threshold voltage, the output gate drive circuit will be shut off simultaneously and stop switching the power MOSFET.

The VCC OVP is auto recovery type of protection. Once the VCC trips OVP level (which is usually caused by the feedback loop opened), the controller will be turn off and it will auto recovery when the VCC reaches UVLO(on). See Fig. 14 for its operation.

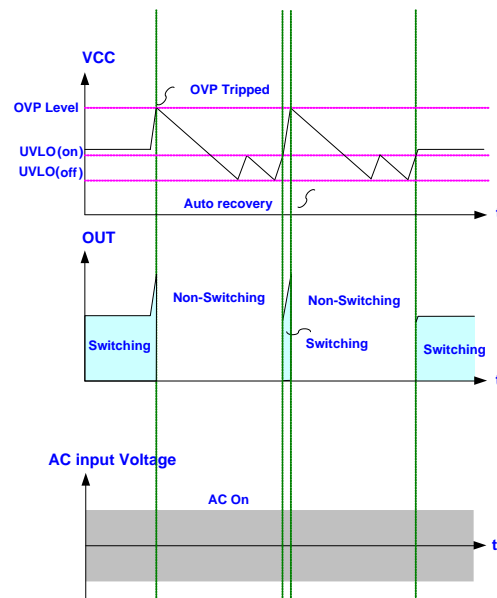

Fig. 14

## On-Chip OTP – Auto Recovery

An internal OTP circuit is embedded inside the LD5762K to provide the worst-case protection for this

controller. When the chip temperature rises higher than the trip OTP level, the output will be disabled until the chip is cooled down below the hysteresis window.

## Over Voltage Protection on FB Pin (FB\_OVP) – Auto Mode

An output overvoltage protection is implemented in the LD5762K. The auxiliary winding voltage can be reflected from secondary winding, in which the FB pin voltage is proportional to output voltage during the gate off time. OVP is worked by sensing the auxiliary voltage via the divided resistors R2, referring to Fig. 15. The equation of FB OVP is shown as follows.

$$R_2 = \frac{R_1 \cdot V_{FB\_OVP}}{V_a - V_{FB\_OVP}}$$

$$V_a = \frac{N_a}{N_s} (V_o + V_F)$$

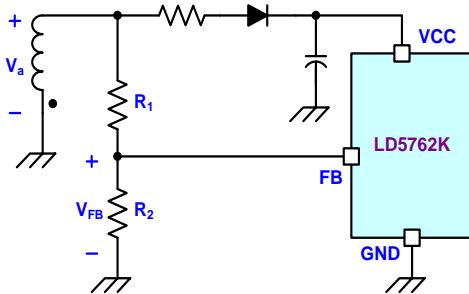

Fig. 15

$V_{FB\_OVP}$  is the FB pin OVP trip voltage level.  $V_a$  is the auxiliary winding voltage which reflects from the forward voltage  $V_F$  of Schottky diode and output voltage  $V_o$ .  $N_s$  is turns ratio of secondary-side winding.

If  $V_{FB}$  overs the  $FB\_OVP$  trip level and  $V_{COMP} > 4.6V$ , the internal counter starts counting 8 cycles, and then LD5762K goes to auto mode.

## Over Bulk Cap Voltage Protection on FB Pin (Bulk\_OVP) – Auto Mode

For preventing the abnormal condition of line voltage to causing bulk cap damage, the auxiliary voltage reflects a proportional bulk voltage during the on time. Fix the internal current  $I_{Bulk\_OVP}$ , the Bulk OVP level could be set by modulating the FB divided resistors and auxiliary voltage, as shown in Fig. 16. The relationship of  $I_{Bulk\_OVP}$  and Bulk voltage is expressed in following equation. This protection is auto mode function.

$$\frac{V_{FB} - V_a}{R_1} = I_{Bulk\_OVP}$$

$$V_a = -\frac{N_a}{N_p} \cdot V_{Bulk}$$

$$V_{Bulk\_OVP} = \frac{N_p}{N_a} \cdot (R_1 \cdot I_{Bulk\_OVP} - V_{FB})$$

, where

$V_{FB}$  is FB pin on time voltage.

$V_a$  is the auxiliary winding voltage reflected from Bulk voltage.

$V_{Bulk\_OVP}$  is predicted Bulk OVP DC value.

$I_{Bulk\_OVP}$  is Bulk OVP trip current.

$N_p$  is turns ratio of primary-side winding.

$N_a$  is turns ratio of auxiliary winding.

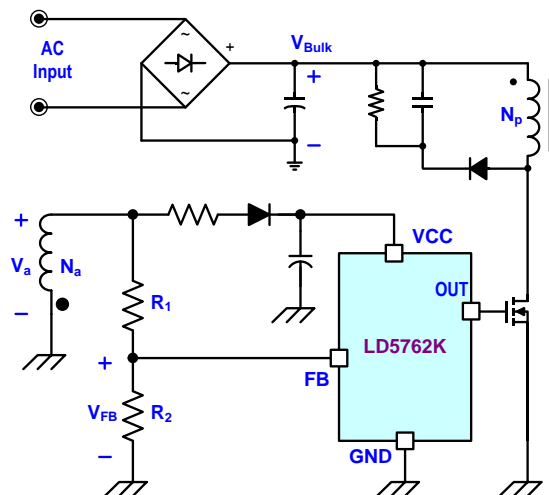

Fig. 16

## Over Temperature Protection on CS Pin (CS OTP) - Auto Mode

LD5762K is implemented over temperature protection on CS pin which senses voltage to determine NTC status during gate off region. As  $V_{CS}$  is greater than 0.28V and continues for 16 cycles, CS\_OTP is triggered, then LD5762K is in auto mode.

## Pull-Low Resistor on the Gate Pin of MOSFET

The LD5762K consists of an anti-floating resistor at OUT pin to protect the output from damage in abnormally operation or condition due to false triggering of MOSFET. Even so, we still recommend adding an external one at the MOSFET gate terminal to provide more protection in case of disconnection of gate resistor  $R_G$  during power-on.

In such single-fault condition, as shown in Fig. 17, the resistor  $R_8$  can provide a discharge path to avoid the MOSFET from being false-triggered by the current through the gate-to-drain capacitor  $C_{GD}$ . Therefore, the MOSFET should be always pulled low and placed in the off-state as the gate resistor is disconnected or opened in any case.

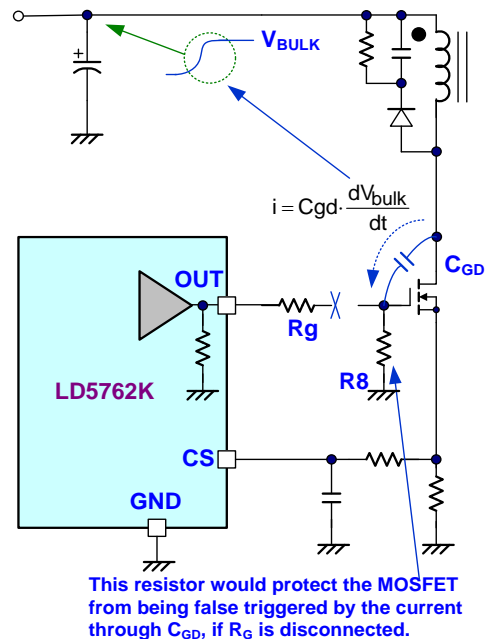

Fig. 17

## Protection Resistor on the Hi-V Path

In some other Hi-V process and design, there may be a parasitic SCR caused around HV pin, VCC and GND. As shown in Fig. 18, a small negative spike on the HV pin may trigger this parasitic SCR and cause latch-up between VCC and GND. It may damage the chip because of the equivalent short-circuit induced by such latch-up behavior.

Hi-V technology will eliminate parasitic SCR in LD5762K. Fig. 19 shows the equivalent Hi-V structure circuit of LD5762K. So that LD5762K is more capable to sustain negative voltage than similar products. However, a 17.5kΩ resistor is recommended to be added in the Hi-V path to play as a current limit resistor whenever a negative voltage is applied.



**Negative-triggered Parasitic SCR.**  
 Small negative spike on HV pin will cause the latchup between Vcc and GND.

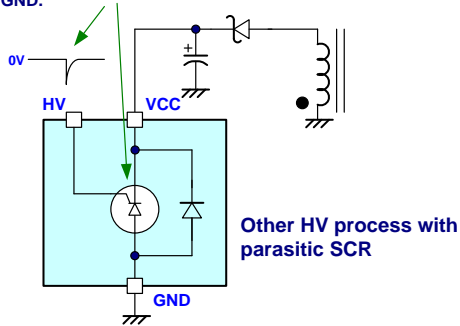

**Fig. 18**

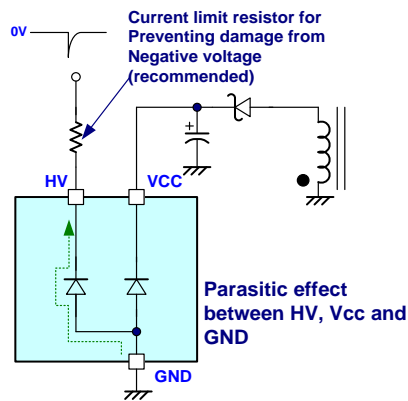

**Fig. 19**

## Package Information

SOP-7

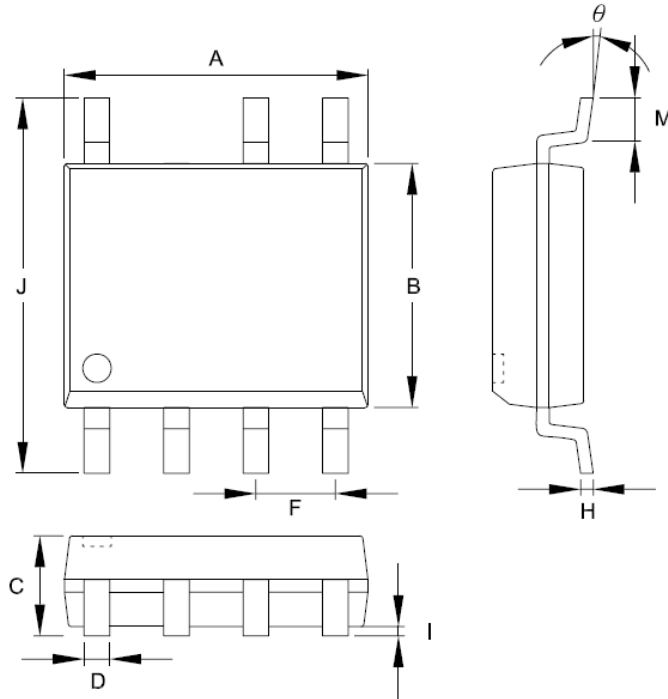

Symbols	Dimensions in Millimeters		Dimensions in Inch	
	MIN	MAX	MIN	MAX
A	4.801	5.004	0.189	0.197
B	3.810	3.988	0.150	0.157
C	1.346	1.753	0.053	0.069
D	0.330	0.508	0.013	0.020
F	1.194	1.346	0.047	0.053
H	0.178	0.254	0.007	0.010
I	0.102	0.254	0.004	0.010
J	5.791	6.198	0.228	0.244
M	0.406	1.270	0.016	0.050
$\theta$	0°	8°	0°	8°

**Revision History**

REV.	Date	Change Notice
00	07/04/2019	Original Specification

**Important Notice**

Leadtrend Technology Corp. reserves the right to make changes or corrections to its products at any time without notice.  
Customers should verify the datasheets are current and complete before placing order.