

APPROVED DATE	 SHARP	SPEC. No. LM11023C
ISSUED DATE : 2011. 8.10		FILE No.
PAGE : 24 pages including cover pages		Display Division Business Solutions Promotion Group SHARP CORPORATION

TECHNICAL LITERATURE

DEVICE SPECIFICATIONS FOR

TFT-LCD module

MODEL No. LD600T3SH1

CUSTOMER'S APPROVAL

DATE _____

BY _____

PRESENTED

Engineering Department

BY Kenji Tanaka

Date 2011. 8. 10



LM11023C

RECORDS OF REVISION

MODEL NO. LD600T3SH1

SPEC No.	DATE	REVISED No.	SUMMARY		NOTE
			PAGE		
LM11023	2011.7.14		18	Preliminary version	
LM11023A	2011.7.27		—	Revision	
LM11023B	2011.8.2		—	Revision	
LM11023C	2011.8.10		—	authoritative version issued	



1. Application

This specification applies to the color 60.0" TFT-LCD module LD600T3SH1.

- *This document are the proprietary product of SHARP CORPORATION ("SHARP") and include materials protected under copyright of SHARP. Do not reproduce or cause any third party to reproduce them in any form or by any means, electronic or mechanical, for any purpose, in whole or in part, without the express written permission of SHARP.
- *The device listed in this document was designed and manufactured for use in information display.
- *In case of using the device for applications such as control and safety equipment for transportation(aircraft, trains, automobiles, etc.), rescue and security equipment and various safety related equipment which require higher reliability and safety, take into consideration that appropriate measures such as fail-safe functions and redundant system design should be taken.
- *Do not use the device for equipment that requires an extreme level of reliability, such as aerospace applications, telecommunication equipment (trunk lines), nuclear power control equipment and medical or other equipment for life support.
- *SHARP assumes no responsibility for any damage resulting from the use of the device which does not comply with the instructions and the precautions specified in this document.
- *Contact and consult with a SHARP sales representative for any questions about this device.
- *SHARP takes no responsibility for any problems related to any intellectual property right of a third party resulting from the use of products.

2. Overview

This module is a color active matrix LCD module incorporating amorphous silicon TFT (Thin Film Transistor). It is composed of a color TFT-LCD panel, driver ICs, control circuit and LED back light system etc. Graphics and texts can be displayed on a 1366×RGB×768 dots panel with about 16.77 million colors by using 10 bit LVDS (Low Voltage Differential Signaling) to interface and +12V of DC supply voltages.

And in order to improve the response time of LCD, this LCD module applies the Over Shoot driving (O/S driving) technology for the control circuit. In the O/S driving technology, signals are being applied to the Liquid Crystal according to a pre-fixed process as an image signal of the present frame when a difference is found between image signal of the previous frame and that of the current frame after comparing them.

With this technology, image signals can be set so that liquid crystal response completes within one frame. As a result, motion blur reduces and clearer display performance can be realized.

3. Model outline

Parameter	Specifications	Unit
Display size	152.439(Diagonal)	cm
	60.0 (Diagonal)	inch
Active area	1328.7765 (H)×747.072 (V)	mm
Pixel format	1366 (H)×768 (V) (1 pixel=R+G+B dots)	pixel
Pixel pitch	0.97275 (H)×0.97275 (V)	mm
Pixel configuration	R, G, B vertical stripe	
Display mode	Normally black	
Back light	LED Direct With Local dimming function	
Brightness	1,500	cd/m ²
Contrast ratio	Typ. 5,000 : 1<Local dimming OFF>	
Unit outline dimensions (*1)	1335.9 (W)×754.2 (H)×(118.4 (D))	mm
Weight	28.8 ±2.0	kg
Surface treatment	LR coating Hard coating: 2H and more	

(*1)Outline dimensions are shown in Fig.1

4. Input Terminals

4.1. TFT-LCD panel driving

CN6 [LED CONTROL PWB] (Interface signals)

Using connectors : FX16S-41S-0.5SH (HIROSE)

Mating connectors : FX16M1-41P-HC (HIROSE)

Pin No.	Symbol	Function	Remark
1	GND	GND	
2	AIN0-	Aport(-)LVDS CH0 differential data input	
3	AIN0+	Aport(+)LVDS CH0 differential data input	
4	AIN1-	Aport(-)LVDS CH1 differential data input	
5	AIN1+	Aport(+)LVDS CH1 differential data input	
6	AIN2-	Aport(-)LVDS CH2 differential data input	
7	AIN2+	Aport(+)LVDS CH2 differential data input	
8	GND	GND	
9	ACK-	Aport(-)LVDS differential Clock signal	
10	ACK+	Aport(+)LVDS differential Clock signal	
11	AIN3-	Aport(-)LVDS CH3 differential data input	
12	AIN3+	Aport(+)LVDS CH3 differential data input	
13	AIN4-	Aport(-)LVDS CH4 differential data input	
14	AIN4+	Aport(+)LVDS CH4 differential data input	
15	GND	GND	
16	Reserved	-	Pull down to GND with 4.7k Ω resistor.
17	Reserved	-	Pull down to GND with 4.7k Ω resistor.
18	Reserved	-	Pull down to GND with 4.7k Ω resistor.
19	Reserved	-	Pull down to GND with 4.7k Ω resistor.
20	Reserved	-	Pull down to GND with 4.7k Ω resistor.
21	Reserved	-	Pull down to GND with 4.7k Ω resistor.
22	GND	GND	
23	Reserved	-	Pull down to GND with 4.7k Ω resistor.
24	Reserved	-	Pull down to GND with 4.7k Ω resistor.
25	Reserved	-	Pull down to GND with 4.7k Ω resistor.
26	Reserved	-	Pull down to GND with 4.7k Ω resistor.
27	Reserved	-	Pull down to GND with 4.7k Ω resistor.
28	Reserved	-	Pull down to GND with 4.7k Ω resistor.
29	GND	GND	
30	APL_OUTSCALE	Brightness Control	[NOTE2],[NOTE3]
31	Reserved	-	Must be OPEN
32	Reserved	-	Must be OPEN
33	Reserved	-	Must be OPEN
34	APL_OFFSET	Local Dimming Effect Control	[NOTE2],[NOTE3]
35	Reserved	-	Must be OPEN
36	Reserved	-	Must be OPEN
37	Reserved	-	Must be OPEN

38	Reserved	-	Must be OPEN
39	Reserved	-	Must be OPEN
40	Reserved	-	Must be OPEN
41	Reserved	-	Must be OPEN

[NOTE 1] LVDS Data order

Data	
TA0	R4
TA1	R5
TA2	R6
TA3	R7
TA4	R8
TA5	R9(MSB)
TA6	G4
TB0	G5
TB1	G6
TB2	G7
TB3	G8
TB4	G9(MSB)
TB5	B4
TB6	B5
TC0	B6
TC1	B7
TC2	B8
TC3	B9(MSB)
TC4	Hsync
TC5	Vsync
TC6	DE(*)
TD0	R2
TD1	R3
TD2	G2
TD3	G3
TD4	B2
TD5	B3
TD6	NA
TE0	R0
TE1	R1
TE2	G0
TE3	G1
TE4	B0
TE5	B1
TE6	NA

NA: Not Available

(*)Since the display position is prescribed by the rise of DE (Display Enable) signal, please do not fix DE signal during operation at "High".

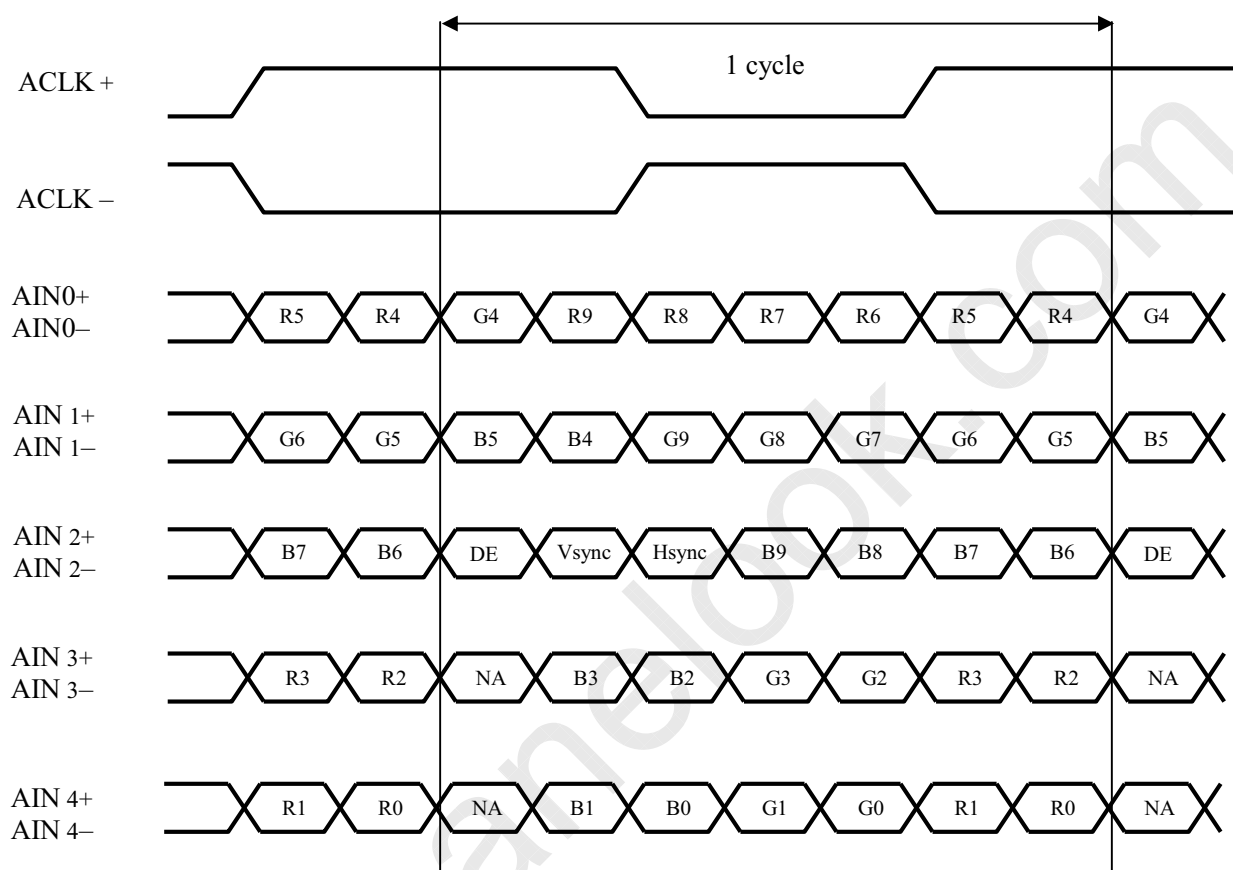

DE: Display Enable, NA: Not Available (Fixed Low)

[NOTE 2] Brightness and Local Dimming Effect Control (Pulse Dimming)

Pin No.30 & 34 are Open Drain control. (They are pulled up internally.)

	MIN	TYP	MAX
OFF	-	-	0.6V

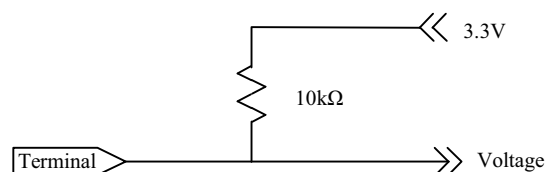

Pin No.30 & 34 are used for the control of the PWM duty with input pulse (450Hz).

Input PWM waveform

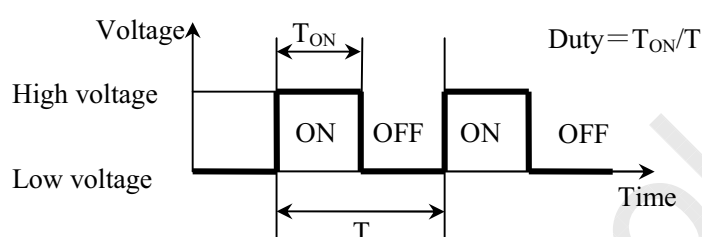

		MIN.	TYP	MAX.	Remark
Pulse signal	[Hz]	445	450	455	
Brightness (Duty)	[%]	5.0	<->	100.0	Ta=25°C Pulse signal=(450) Hz 100%=Maximum Brightness
Local Dimming Effect (Duty)	[%]	5.0	<->	100.0	Ta=25°C Pulse signal=(450) Hz 100%=No effect
Low voltage	V	-	0	0.6	
High voltage	V	3.0	3.3	3.6	

[Note]

- Limit of jitter of frequency: Max. ±0.3%
- If the jitter is over the range above, the screen may flicker.

[NOTE 3] Limitation of Brightness and Local Dimming Effect

- Available value: 96steps for 5.0% to 100.0%. (Ex. 10.0% or 77.0%)
: MAX. ±0.05%

- If the value does not meet the condition above (Ex. 10.3% or 77.6%), the screen may flicker.
- When the product of Brightness and Local Dimming Effect is less than 5.0%, the screen may blackout.
- In case of the product above is less than 5.0%, please limit the Local Dimming Effect as follows.

$$-LocalDimmingEffect[\%] \geq 100 \times \frac{5.0}{Brightness[\%]}$$

(Setting example)

Brightness	Local Dimming Effect	
	MIN. (Strong Effect)	MAX. (No Effect)
100%	5%	100%
50%	10%	100%
10%	50%	100%

CN5 [LED CONTROL PWB] (+12V DC power supply)

Using connectors : SM07B-PASS-TBT (JST)

Mating connectors : PAP-07V-S (JST)

Pin No.	Symbol	Function	Remark
1	VCC	+12V Power Supply	
2	VCC	+12V Power Supply	
3	-	-	Must be OPEN
4	-	-	Must be OPEN
5	-	-	Must be OPEN
6	GND	GND	
7	GND	GND	

CN7 [LED CONTROL PWB] (Control Signals)

Using connectors : S18B-PUDSS-1 (JST)

Mating connectors : PUDP-18V-S (JST)

Pin No.	Symbol	Function	Remark
1	GND	GND	
2	-	-	Must be OPEN
3	-	-	Must be OPEN
4	nLCD_ON	LCD ON/OFF control	[NOTE2]
5	-	-	Must be OPEN
6	-	-	Must be OPEN
7	GND	GND	
8	-	-	Must be OPEN
9	-	-	Must be OPEN
10	GND	GND	
11	TEST	Connect to GND	Connect to GND
12	nLED_ON	LED ON/OFF control	[NOTE1]
13	nRDY	Control Status	[NOTE3]
14	nLED_ERR	LED Error	[NOTE4]
15	-	-	Must be OPEN
16	-	-	Must be OPEN
17	nMODE	Local Dimming ON/OFF control	[NOTE1]
18	GND	GND	Must be OPEN

[NOTE 1] ON/OFF

	MIN	TYP	MAX
ON	-	-	0.6V

These ports are Open Drain control.

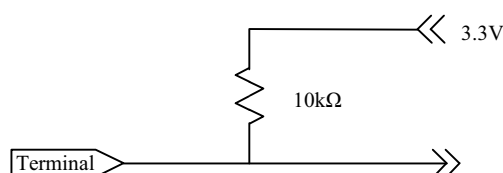

[NOTE 2] ON/OFF

	MIN	TYP	MAX
ON	-	-	0.45V

This port is Open Drain control.

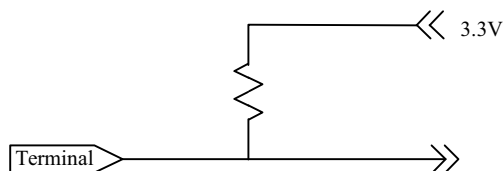

[NOTE 3] Ready Detection

	MIN	TYP	MAX
Busy	Open Drain		
Ready	-	-	0.4V

Please use the terminal as follows. (Pull-up)

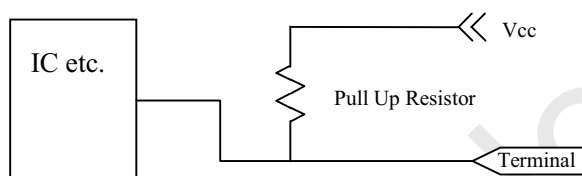

[NOTE 4] LED Error Detection

	MIN	TYP	MAX
Error	-	-	0.4V
No Error	Open Drain		

If the state of nLED_ERR is error, please restart (turn off and then turn on) the module.
Please use the terminal as follows. (Pull-up)

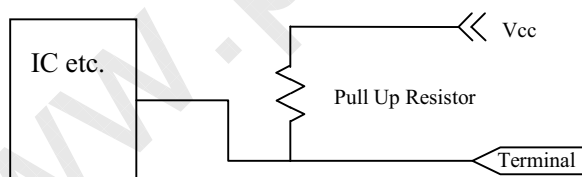

CN5 [LED DRIVER PWB] (LED Power supply)

Using connectors : B6P-VH-B (JST)

Mating connectors : VHR-6N (JST)

Pin No.	Symbol	Function	Remark
1	24V1	+24V Power Supply	
2	24V2	+24V Power Supply	
3	24V3	+24V Power Supply	
4	GND	GND	
5	GND	GND	
6	GND	GND	

CN6 [LED DRIVER PWB] (LED Power supply)

Using connectors : B7P-VH-B (JST)

Mating connectors : VHR-7N (JST)

Pin No.	Symbol	Function	Remark
1	24V4	+24V Power Supply	
2	24V5	+24V Power Supply	
3	24V6	+24V Power Supply	
4	NC	NC	
5	GND	GND	
6	GND	GND	
7	GND	GND	

4.2. Interface block diagram

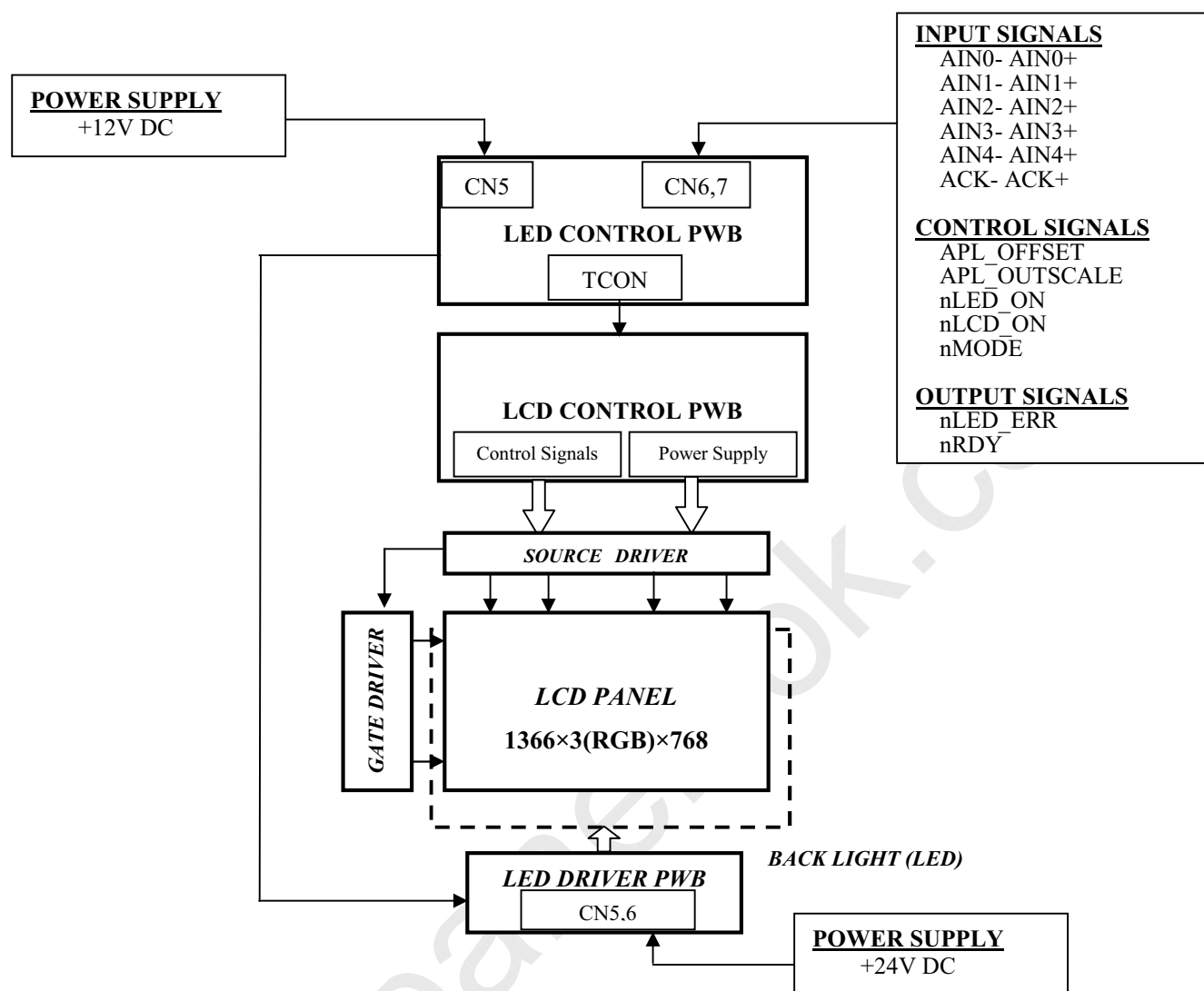

4.3. The back light system characteristics

The back light system is direct type with 1152 LEDs.

The characteristics of the LED are shown in the following table.

Item	Symbol	Min.	Typ.	Max.	Unit	Remarks
Life time	T_L	—	(37000)	—	Hour	[NOTE]

[NOTE]

- LED life time is defined as the time when brightness become 70% of the original value in the continuous Operation under the condition of $T_a=25^\circ\text{C}$

5. Absolute Maximum Rating

Parameter	Symbol	Condition	Ratings	Unit	Remark
Input Voltage (for Control)	V_I	$T_a=25^{\circ}\text{C}$	-0.3 ~ 3.6	V	[NOTE1]
12V supply voltage (for Control)	VCC	$T_a=25^{\circ}\text{C}$	0 ~ 14	V	
Storage temperature	T_{stg}		-25 ~ 60	$^{\circ}\text{C}$	
Operation temperature (Ambient)	T_{opa}		0 ~ 50	$^{\circ}\text{C}$	[NOTE2]
LED terminal temperature	T_c		0 ~ 80	$^{\circ}\text{C}$	[NOTE3], [NOTE4]
LCD surface temperature	$T_{\text{sf}}c$		0 ~ 60	$^{\circ}\text{C}$	[NOTE4]

[NOTE1] APL_OFFSET, APL_OUTSCALE, nLCD_ON, nLED_ON, nMODE: Open Drain Inputs

[NOTE2] Humidity 95% RH Max ($T_a \leq 40^{\circ}\text{C}$)

Maximum wet-bulb temperature should be less than 40°C . ($T_a > 40^{\circ}\text{C}$)

No condensation.

[NOTE3] LED terminal temperature should be measured on the LED PWBs.

[NOTE4] T_c and $T_{\text{sf}}c$ in operation must be in the above range on any condition.

6. Electrical Characteristics

6.1 Control Circuit driving

Parameter		Symbol	Min.	Typ.	Max	Unit	Remark
+12V supply voltage	Supply voltage	VCC	11.4	12.0	12.6	V	
	Current dissipation	ICC		1.5	2.1	A	[NOTE 6]
Permissible input ripple voltage		V _{RP}	—	—	—	mV	
Differential input threshold voltage	High	V _{TH}		—	+100	mV	[NOTE 1], [NOTE 5]
	Low	V _{TL}	-100	—		mV	
Common mode Voltage (@ V _{id} =100mV)		V _{CM}	0.2	1.2	2.0	V	
Differential input voltage		V _{id}	100		600	mV	
Differential input leak current		I _{lz}	10	—	10	μA	
Input Low voltage1		V _{IL1}	-	-	0.6	V	[NOTE 2]
Input High voltage1		V _{IH1}	-	-	-	V	
Input Low voltage2		V _{IL2}	-	-	0.45	V	[NOTE 3]
Input High voltage2		V _{IH2}	-	-	-	V	
Output Low voltage		V _{OL}	—	—	0.4	V	[NOTE 4]
Output High voltage		V _{OH}	—	—	—	V	
Input leak current1		I _{IL1}	—	—	400	μA	V _I =0V [NOTE2]
Input leak current2		I _{IL2}	—	—	4	mA	V _I =0V [NOTE3]
Terminal resistor		R _T	—	100	—	Ω	

[NOTE 1] ACK±, AIN0±, AIN1±, AIN2±, AIN3±, AIN4± @V_{CM}=1.2V

[NOTE 2] APL_OFFSET, APL_OUTSCALE, nLED_ON, nMODE, TEST: Open Drain Inputs

[NOTE 3] nLCD_ON: Open Drain Inputs

[NOTE 4] nLED_ERR, nRDY: OpenDrain Output

[NOTE 5] V_{CM}: Common mode voltage of LVDS driver.

[NOTE 6] Typical current situation: 1024 gray-bar patterns. (VCC = +12.0V)

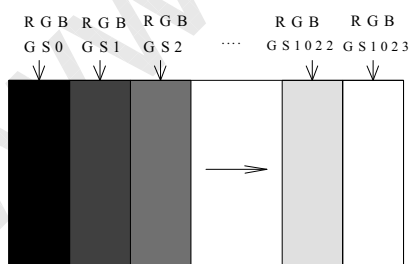

VCC = +12.0V

Clock = 82.496MHz

TH = 20.70 μs

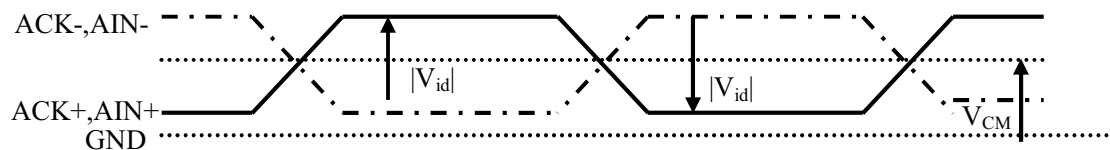

6.2 LED Circuit driving

Parameter	Symbol	Min.	Typ.	Max	Unit	Remark
Input voltage	LED VCC	(22.8)	24.0	25.2	V	
Input current	LED ICC	(0)	16.5	23 (3.84 A/port)	A	Recommend the power capacity more than 30A.

6.3 Sequence

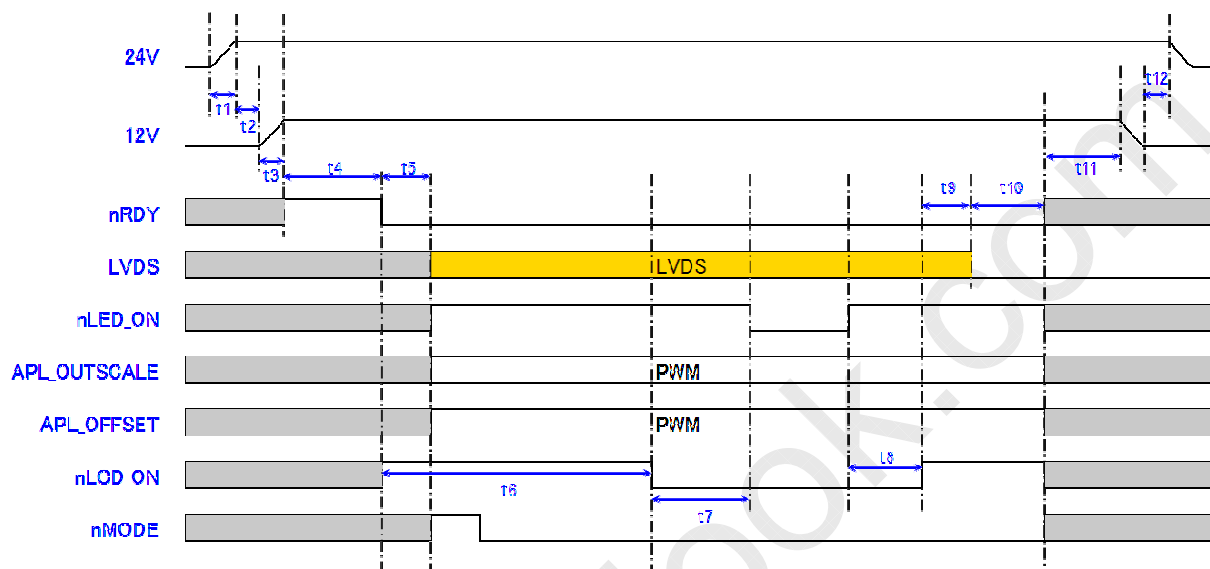

Panel ON sequences

- $0 < t1 \leq 200 \text{ ms}$
- $t2 \geq 0 \text{ ms}$
- $0 < t3 \leq 200 \text{ ms}$
- $0 < t4 \leq 40 \text{ s}$ (wait for assert in this range)
- $0 \leq t5 \leq 250 \text{ ms}$
- $t6 \geq 600 \text{ ms}$
- $t7 \geq 1000 \text{ ms}$

Panel OFF sequences

- $t8 \geq 50 \text{ ms}$
- $t9 \geq 0 \text{ ms}$
- $t10 \geq 0 \text{ ms}$
- $t11 \geq 0 \text{ ms}$
- $t12 \geq 0 \text{ ms}$

[Note] About the relation between data input and back light lighting, please base on the above-mentioned input sequence. When back light is switched on before panel operation or after a panel operation stop, it may not display normally. But this phenomenon is not based on change of an incoming signal, and does not give damage to a liquid crystal display.

In Panel ON sequence, please input black data (GS0) for LVDS when back light is not turned on.

6.4 Timing characteristics of input signals

Timing diagrams of input signal are shown in Fig.1.

Parameter		Symbol	Min.	Typ	Max.	Unit	Remark
Clock	Frequency	1/Tc	-	82.496	-	MHz	[NOTE1]
Data enable signal	Horizontal period	TH	-	1708	-	clock	
			-	20.70	-	μs	
	HSync		-	96	-	clock	
	Horizontal back porch		-	124	-	clock	
	Horizontal period (High)	THd	-	1366	-	clock	
	Horizontal front porch		-	122	-	clock	
	Vertical period	TV	797	805	813	line	[NOTE2]
			-	60	-	Hz	
	VSync		-	2	-	line	
	Vertical back porch		-	5	-	line	
	Vertical period (High)	TVd	-	768	-	line	
Vertical front porch		22	30	38	line		

[Note]-When vertical period is out of range above, flicker and etc. may occur.

-When Horizontal period is different from above TH value, the screen may blackout.

-Please turn off the module after it shows the black screen.

-Please make sure that length of vertical period should become of an integral multiple of horizontal length of period. Otherwise, the screen may not display properly.

-As for your final setting of driving timing, we will conduct operation check test at our side, please inform your final setting.

[NOTE1]

Limit of SS modulation (Spread Spectrum Modulation): Frequency: 30~60 kHz

: Modulation factor: Max. ±1%

[NOTE2]

Limit of secular change of vertical period: Max. ±1 line/frame

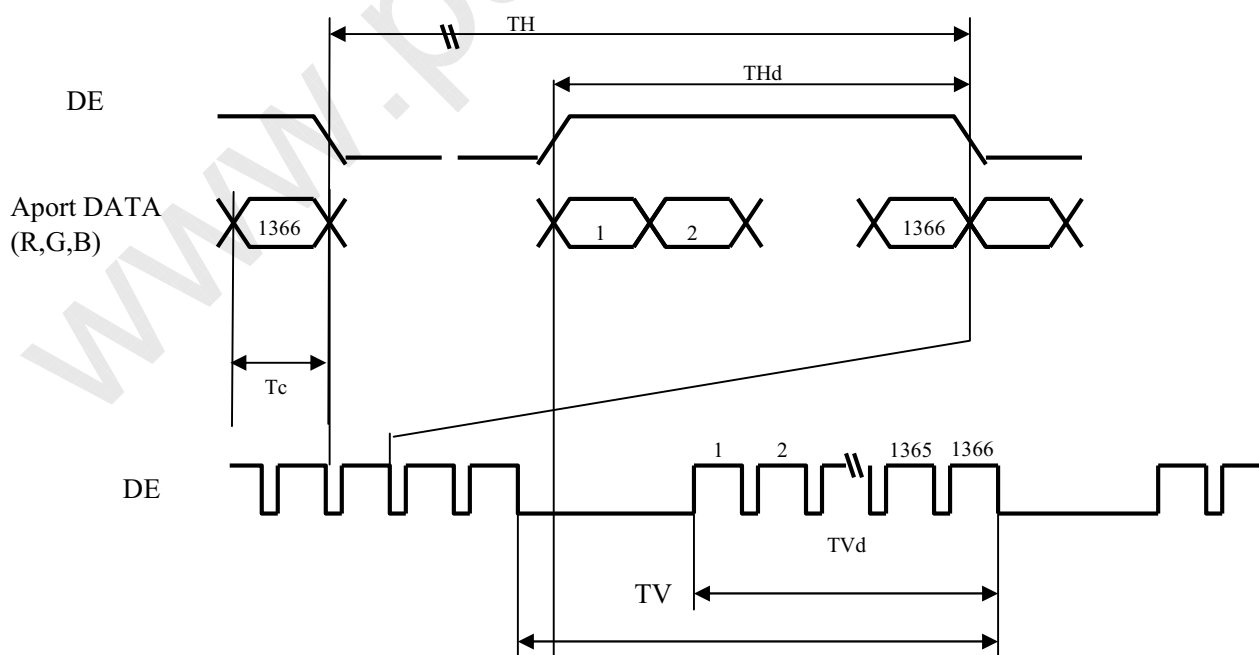

Timing characteristics of input signals

7. Optical characteristics

Ta=25°C, VCC=12.0V, LED ICC=45mA, LED PWM Burst= 99.97% , Timing :60Hz (typ.value)

Parameter	Symbol	Condition	Min.	Typ.	Max.	Unit	Remark	
Contrast ratio	CRn	$\theta=0^\circ$	3500	5000	—	—	[NOTE2,4]	
Luminance of white	x	$\theta=0^\circ$	0.257	0.287	0.317	—	[NOTE4]	
	y		0.265	0.295	0.325	—		
Luminance of red	x		0.613	0.643	0.673	—		
	y		0.316	0.346	0.376	—		
Luminance of green	x		0.284	0.314	0.344	—		
	y		0.603	0.635	0.665	—		
Luminance of blue	x		0.124	0.154	0.184	—		
	y		0.038	0.068	0.098	—		
Viewing angle range	Horizontal	θ_{21}, θ_{22}	CR \geq 10	—	88	—	deg	[NOTE1,4]
	Vertical	θ_{11}, θ_{12}		—	88	—	deg	
Luminance	Y_L	White	—	1500	—	cd/m ²	[NOTE4]	
Luminance uniformity	δw	$\theta=0^\circ$	—	1.25	—	—	[NOTE5]	
Response time	τ	$\theta=0^\circ$	—	6	—	ms	[NOTE3,4]	

Measurement condition: Set the LED PWM Burst to maximum

The measurement shall be executed 60 minutes after lighting at rating.

[Note]The optical characteristics are measured using the following equipment.

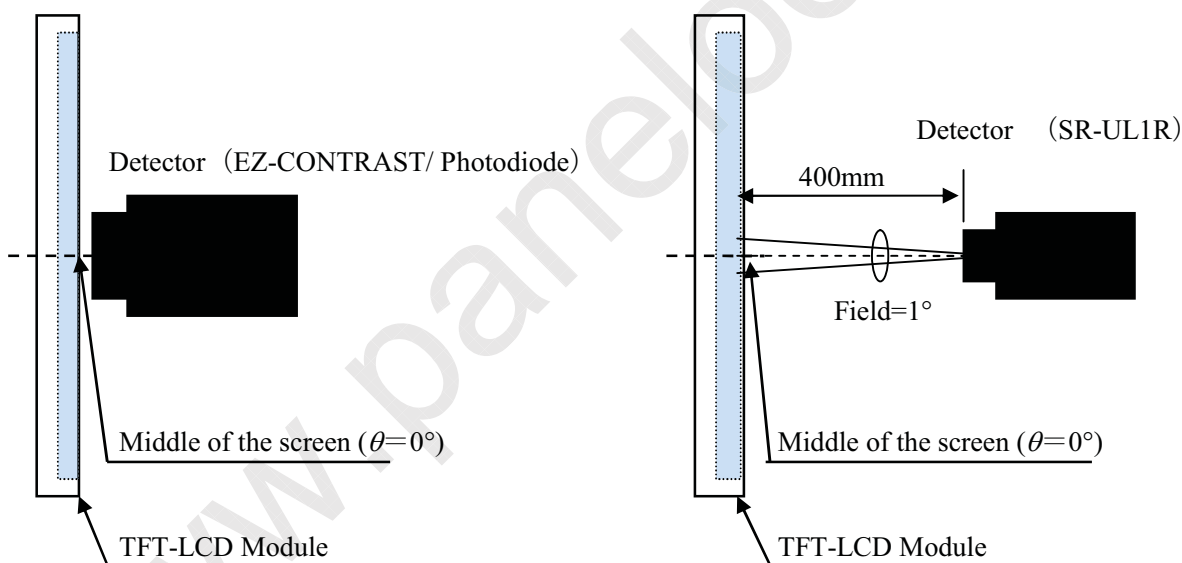

Measurement of viewing angle range and Response time.

Viewing angle range: EZ-CONTRAST

Response time: Photodiode

Measurement of Contrast, Luminance, Chromaticity.

[Note 1]Definitions of viewing angle range :

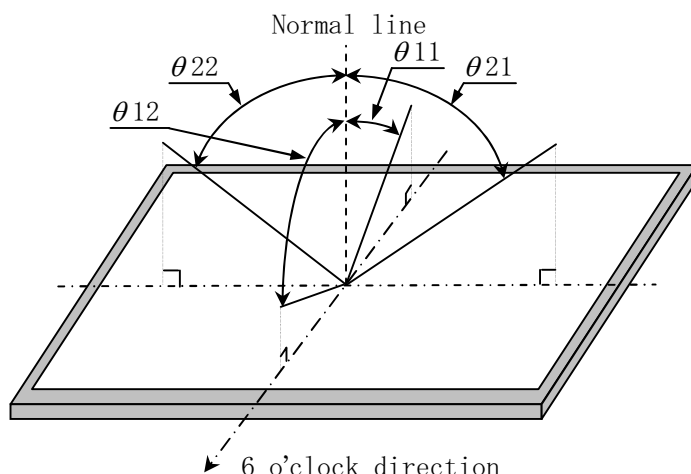

[Note 2]Definition of contrast ratio :

The contrast ratio is defined as the following.

$$\text{Contrast Ratio} = \frac{\text{Luminance (brightness) with all pixels white}}{\text{Luminance (brightness) with all pixels black}}$$

[Note 3]Definition of response time

The response time (T_{DRV}) is defined as the following figure and shall be measured by switching the input signal for “any level of gray (0%, 25%, 50%, 75% and 100%)” and “any level of gray (0%, 25%, 50%, 75% and 100%)”.

	0%	25%	50%	75%	100%
0%		tr:0%-25%	tr:0%-50%	tr:0%-75%	tr:0%-100%
25%	td: 25%-0%		tr: 25%-50%	tr25%-75%	tr: 25%-100%
50%	td: 50%-0%	td: 50%-25%		tr: 50%-75%	tr: 50%-100%
75%	td: 75%-0%	td: 75%-25%	td: 75%-50%		tr: 75%-100%
100%	td: 100%-0%	td: 100%-25%	td: 100%-50%	td:100%-75%	

t*:x-y...response time from level of gray(x) to level of gray(y)

$$\tau_{DRV} = \{ \Sigma (\text{tr}:x-y) + \Sigma (\text{td}:x-y) \} / 20$$

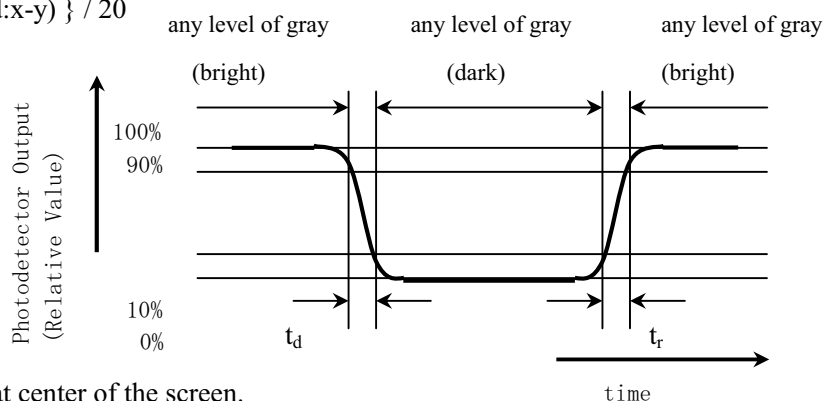

[Note 4]This shall be measured at center of the screen.

[Note 5] Definition of white uniformity ;

White uniformity is defined as the following with five measurements. (A~E)

$$\delta_w = \frac{\text{Maximum luminance of five points (brightness)}}{\text{Minimum luminance of five points (brightness)}}$$

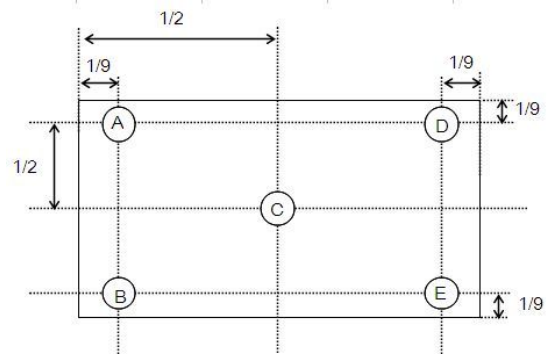

8. Handling Precautions of the LCD module

- a) Be sure to turn off the power supply when inserting or disconnecting the cable.
- b) Be sure to design the cabinet so that the LCD module can be installed without any extra stress such as warp or twist.
- c) Since the front polarizer is easily damaged, pay attention not to scratch it.
- d) Since long contact with water may cause discoloration or spots, wipe off water drop immediately.
- e) When the panel surface is soiled, wipe it with absorbent cotton or other soft cloth.
- f) Since the panel is made of glass, it may break or crack if dropped or bumped on hard surface. Handle with care.
- g) Since CMOS LSI is used in this LCD module, take care of static electricity and take the human earth into consideration when handling.
- h) The LCD module has some printed circuit boards (PCBs) on the back side, take care to keep them from any stress or pressure when handling or installing the module; otherwise some of electronic parts on the PCBs may be damaged.
- i) Observe all other precautionary requirements in handling components.
- j) When some pressure is added onto the module from rear side constantly, it causes display non-uniformity issue, functional defect, etc.. So, please avoid such design.
- k) When giving a touch or hit the panel in supplying power, it may cause some kinds of degradation. In that case, once turn off the power supply, and turn on after several seconds again, and that is disappear.
- l) When handling LCD modules or assembling them into cabinets, please be noted that long-term storage in the environment of oxidization or deoxidization gas and the use of such materials as reagent, solvent, adhesive, resin, etc. which generate these gasses, may cause corrosion and discoloration of the LCD modules.
- m) Make sure that the LCD module is operated within specified temperature and humidity. Measures to avoid dust, water, vibration, Infrared, Ultraviolet and heat radiation, etc. are required with cabinet or other way. And image retention may occur if same fixed pattern is displayed for a long time. In some cases, it may not disappear. Please consider the design and operating environment.
- n) When the LCD module is covered with condensation, please never turn on the power.

9. Outline dimensions

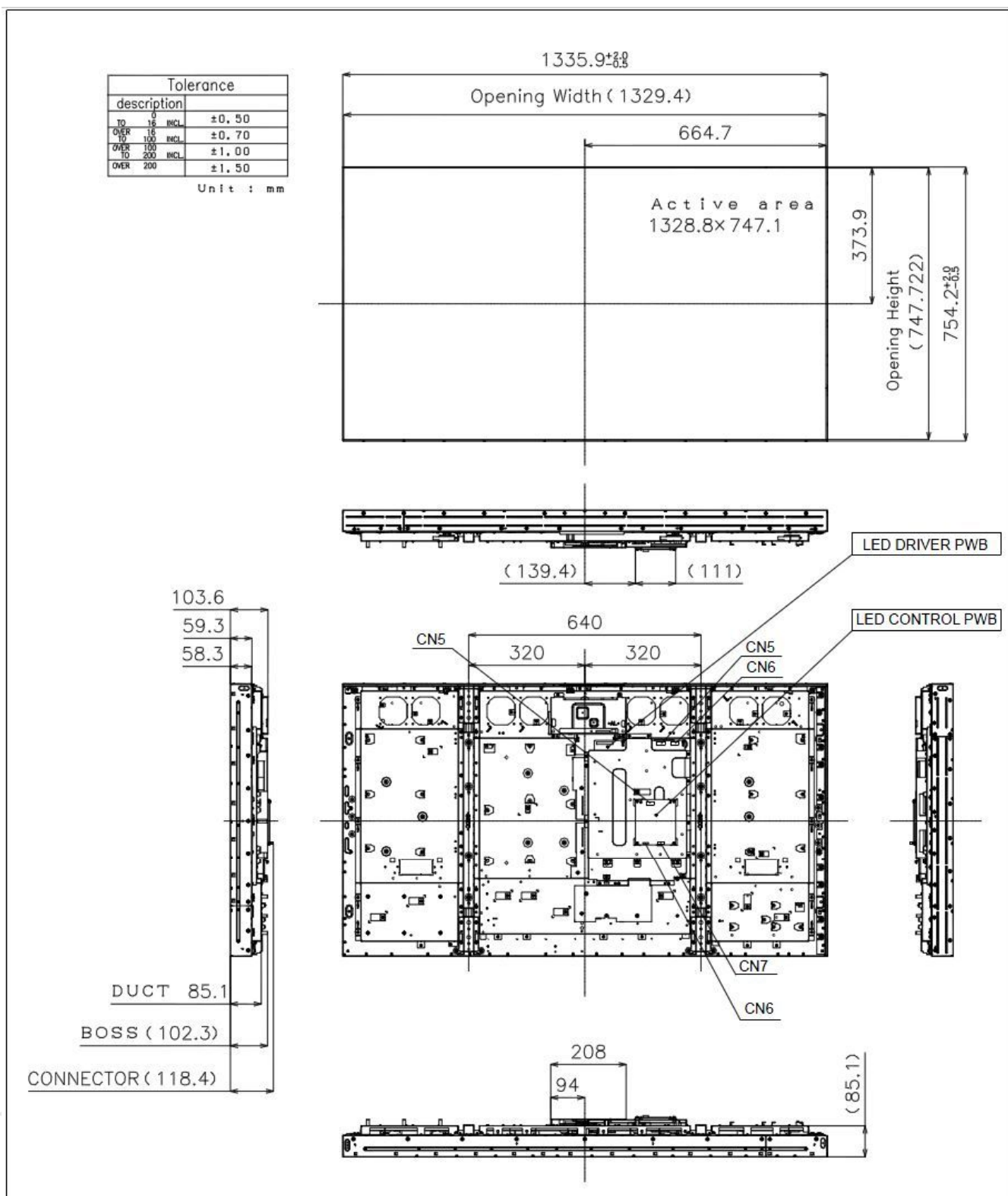

Fig.1 Outline dimensions

10. Packing form

- a) Quantity of LCD Modules in one pallet: 4 LCD Modules
- b) Piling number of pallet: 1 maximum
- c) Pallet size: 1480 (W) × 575 (D) × 1040(H) mm
- d) Pallet gross weight : approximately 139 kg
- e) Packing Form are shown in Fig. 2

[Note] Pallet transportation is required in mass transportation like Sea, Air, Track, Train or others.

11. Reliability test item

No.	Test item	Condition
1	High temperature storage test (in package)	Ta=60 °C 48h
2	Low temperature storage test (in package)	Ta=-25 °C 48h
3	High temperature and high humidity operation test	Ta=40 °C ; 95%RH 48h (Conditions : Assembled in to the SHARP Unit/ No condensation)
4	High temperature operation test	Ta=40 °C 240h (Conditions :Assembled in to the SHARP Unit/ No condensation)
5	Low temperature operation test	Ta=0 °C (Conditions : Assembled in to the SHARP Unit/ No condensation/Operation test after five hours power-off)
6	Vibration test (non-operation / in package)	Frequency : 10~50Hz/Acceleration: (9.8 m/s ²) Sweep time : 3 minutes Test period : 1.5 hours (1 hour for direction of Z, 15min for each direction of X, Y,) Ta=25±2 °C
7	Shock test (non-operation / in package)	Fall 200mm in height /4 ridges/ (Drop test with support of the other side ridge) Ta=25±2 °C
8	ESD (operation)	At the following conditions, it is a thing without incorrect operation and destruction. (1)Contact electric discharge +/-4kV (2)Non-contact electric discharge +/-8kV Electric discharge point : bezel screws/operation panel (Conditions : 150pF, 330ohm Ta=25±2 °C , Assembled in to the SHARP Unit)

[Result evaluation criteria]

Under the display quality test condition with normal operation state, there shall be no change, which may affect practical display function.

[Note]

In display quality test, LCD module should be put with the surface perpendicular to a level surface like following fig.

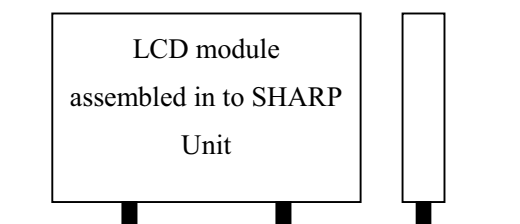

12. Others

1)-1 Module Label ;

Module Label is stuck on the back side of the module.



How to express Serial No.

1 C 0 0 0 0 1 2

A production year (the last 1 digit of the Christian Era)

Code of Production charge section

Serial No.

A production month

(1~10, October: 0, November: X, December: Y)

1)-2 Material Label ;

Material Label is stuck on the back side of the module.

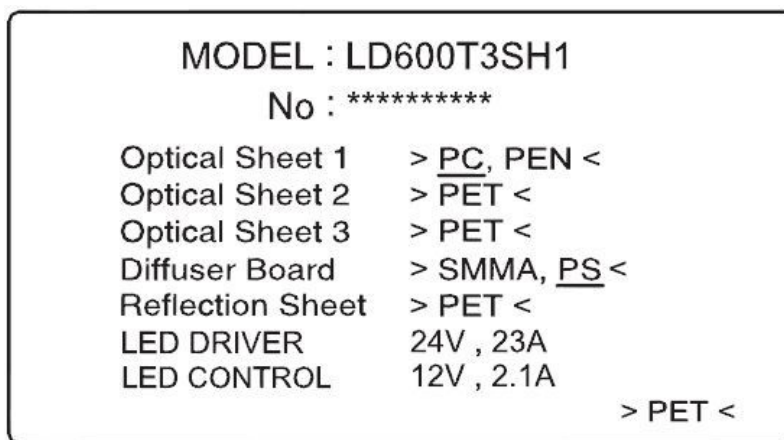

2) Disassembling the module can cause permanent damage and should be strictly avoided.

3) Please be careful since image retention may occur when a fixed pattern is displayed for a long time.

4) Lead-free soldering is applied.

5) The chemical compound, which causes the destruction of ozone layer, is not being used.

6) Rust on the module is not taken up a problem.

7) Ventilation and cooling measurement should be taken to keep away from high temperature.

13. Carton storage condition

Temperature 0 °C to 40 °C

Humidity 95%RH or less

Reference condition : 20 °C to 35 °C, 85%RH or less (summer)

: 5 °C to 15 °C, 85%RH or less (winter)

Sunlight Be sure to keep the LCD module away from direct sunlight.

Atmosphere Harmful gas, such as acid and alkali which bites electronic components and/or wires must not be detected.

Notes Be sure to keep the LCD module in the carton on palette, don't put it on floor. Please take care of ventilation in storehouse and around cartons, and control changing temperature is within limits of natural environment

Storage life 1 year

14. Packing form

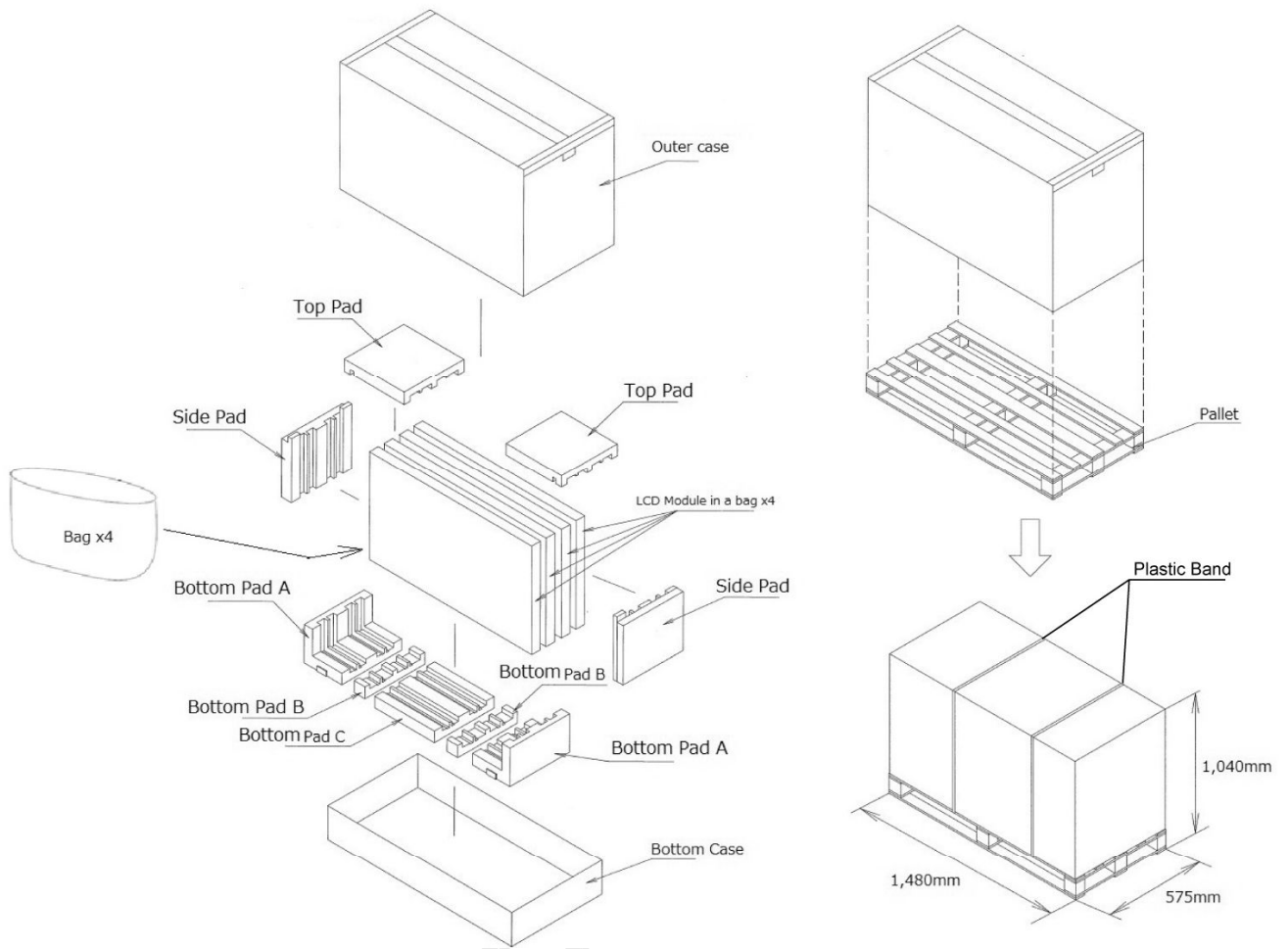

Fig.2 PACKING FORM

www.panelook.com

15. Environmental Impact Substances Information

产品中有毒有害物质或元素的名称及含量

部件名称	有毒有害物质或元素					
	铅 (Pb)	汞 (Hg)	镉 (Cd)	六价铬 (Cr(VI))	多溴联苯 (PBB)	多溴二苯醚 (PBDE)
液晶组件 (LCD module)	×	○	○	○	○	○
<p>○: 表示该有毒有害物质在该部件所有均质材料中的含量均在SJ/T 11363-2006 标准规定的限量要求以下。</p> <p>×: 表示该有毒有害物质至少在该部件的某一均质材料中的含量超出SJ/T 11363-2006 标准规定的限量要求。</p>						